

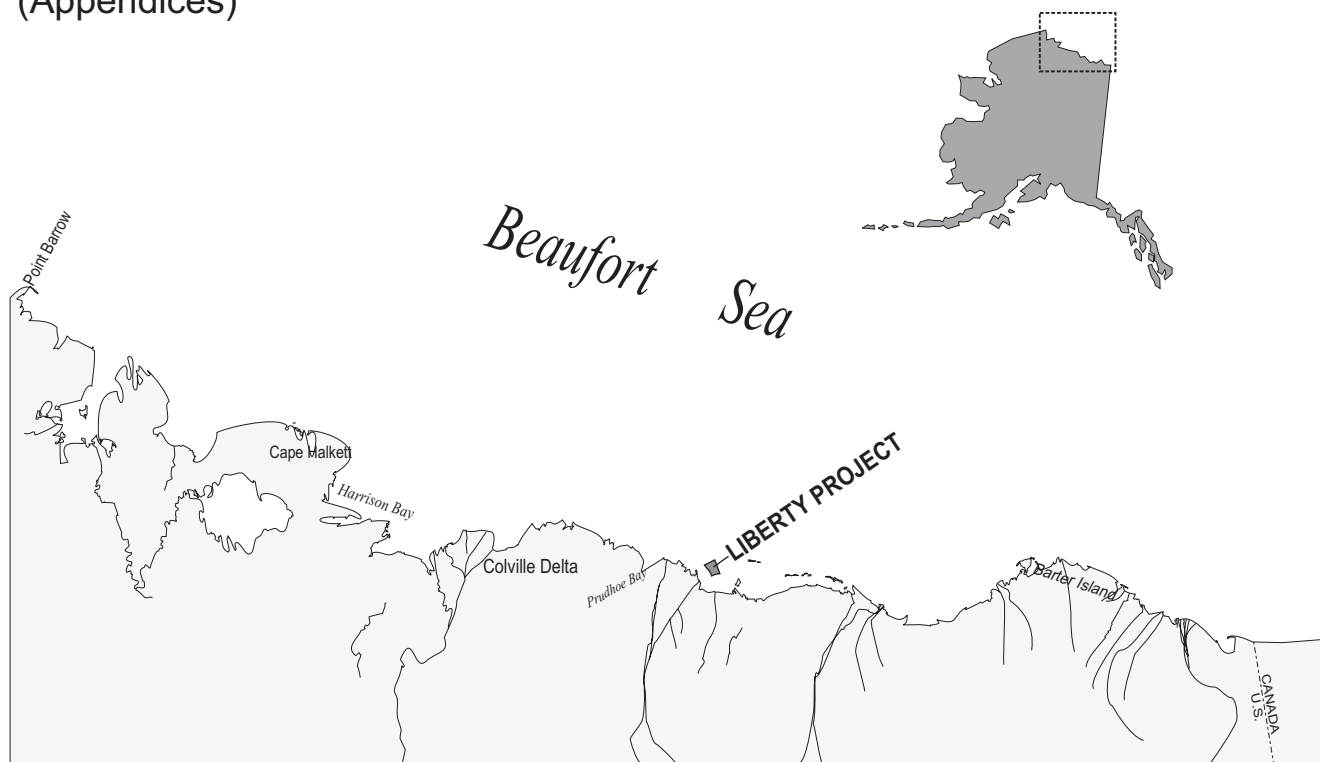

Liberty Development and Production Plan

Final Environmental
Impact Statement

Volume IV
(Appendices)



U.S. Department of the Interior
Minerals Management Service
Alaska OCS Region

Liberty Development and Production Plan, Final Environmental Impact Statement,

OCS EIS/EA, MMS 2002-019, in 4 volumes:

Volume I, Executive Summary, Sections I through V,

Volume II Sections VI through IX, Bibliography, Index

Volume III, Tables, Figures, and Maps for Volumes I and II

Volume IV, Appendices

The summary is also available as a separate document:

Executive Summary, **MMS 2002-020**.

The complete EIS is available on CD-ROM (**MMS 2002-019 CD**) and on the Internet

(<http://www.mms.gov/alaska/cproject/liberty/>).

This Environmental Impact Statement (EIS) is not intended, nor should it be used, as a local planning document by potentially affected communities. The exploration, development and production, and transportation scenarios described in this EIS represent best-estimate assumptions that serve as a basis for identifying characteristic activities and any resulting environmental effects. Several years will elapse before enough is known about potential local details of development to permit estimates suitable for local planning. These assumptions do not represent a Minerals Management Service recommendation, preference, or endorsement of any facility, site, or development plan. Local control of events may be exercised through planning, zoning, land ownership, and applicable State and local laws and regulations.

With reference to the extent of the Federal Government's jurisdiction of the offshore regions, the United States has not yet resolved some of its offshore boundaries with neighboring jurisdictions. For the purposes of the EIS, certain assumptions were made about the extent of areas believed subject to United States' jurisdiction. The offshore-boundary lines shown in the figures and graphics of this EIS are for purposes of illustration only; they do not necessarily reflect the position or views of the United States with respect to the location of international boundaries, convention lines, or the offshore boundaries between the United States and coastal states concerned.

The United States expressly reserves its rights, and those of its nationals, in all areas in which the offshore-boundary dispute has not been resolved; and these illustrative lines are used without prejudice to such rights.



Liberty Development and Production Plan

Final Environmental
Impact Statement

Volume IV (Appendices)

Author
Minerals Management Service
Alaska OCS Region

Cooperating Agencies
U.S. Army Corps of Engineers
Alaska District Office

U.S. Environmental Protection Agency
Region 10

U.S. Department of the Interior
Minerals Management Service
Alaska OCS Region

May 2002

Notice to Readers Regarding the Status of the Liberty Development and Production Plan (DPP)

In January 2002, BP Exploration (Alaska) Inc. (BPXA) publicly announced they were putting the Liberty Project on hold pending an ongoing re-evaluation of project configuration and costs. On March 5, 2002, BPXA sent a letter to Minerals Management Service (MMS) and others saying that pending completion of project re-evaluation, affected agencies should consider submitted permit applications incomplete and recommended processing of these applications be suspended. Also in March, BPXA indicated informally that submission of a modified DPP for the Liberty Project would likely take six months or more.

The MMS has decided to publish and file with Environmental Protection Agency (EPA) this final environmental impact statement (EIS) for the Liberty DPP because it includes substantial changes made in response to comments on the draft EIS. Also, MMS expects this final EIS will serve as a reference document for future projects.

The U.S. Army Corps of Engineers (Corps) and EPA, as cooperating agencies, had intended to use this final EIS as the NEPA document supporting permitting decisions by these agencies. The Corps and EPA hereby solicit comments on the adequacy of, and alternatives considered in, this final EIS.

Due to the applicant's re-evaluation of the project design, and the incomplete status of permit applications, the Corps and EPA are not soliciting comments on their permit decisions at this time. When revised permit applications are received with project changes, the Corps and EPA will issue public notices to request comments on the project proposal. Depending on the changes made, comments received, and any new information available, the three agencies will evaluate whether or not to use this final EIS as the primary NEPA documentation, issue a supplemental EIS or issue new environmental documentation to meet the agencies' respective NEPA compliance and permit evaluation requirements.

TABLE OF CONTENTS

Table of Contents

VOLUME IV — Appendices

A Oil-Spill-Risk Analysis

B* Overview of Laws, Regulations, and Rules

C Endangered Species Act, Section 7 Consultation and Coordination

- C-1 NOAA/National Marine Fisheries Service Endangered Species Act, Section 7 Biological Opinion for BP Exploration's Proposed Liberty Development and Production Plan
- C-2 Fish and Wildlife Service Endangered Species Act, Section 7 Biological Opinion for BP Exploration's Proposed Liberty Development and Production Plan

D EIS Supporting Documents

- D-1 Economic Analysis of the Development Alternatives for the Liberty Prospect, Beaufort Sea, Alaska
- D-2* An Engineering Assessment of Double Wall versus Single Wall Designs for Offshore Pipelines in an Arctic Environment (C-Core, 2000)
- D-3* Assessment of Extended Reach Drilling Technology to Develop the Liberty Reservoir from Alternative Surface Locations
- D-4* Final Report: Independent Evaluation of Liberty Pipeline System Design Alternatives Design Alternatives – Summary (Stress, 2000)
- D-5* Evaluation of Pipeline System Alternatives: Executive Summary Response to MMS, Agency and Stress Engineering Comments – Liberty Pipeline System Alternatives (INTEC, 2000)
- D-6* Independent Risk Evaluation for the Liberty Pipeline – Executive Summary (Fleet, 2000)
- D-7 State Fire Marshal's Position on Double-Walled Piping for Hazardous Liquid Systems (California State Fire Marshal, Pipeline Safety Division, October 30, 1998)
- D-8 Survey of Proposed Liberty Project Gravel Source Areas for Evidence of Bird and Mammal Use (MMS, 2001)
- D-9** Numerical Modeling of the Fate of Suspended Sediments Resulting from the Liberty Project

E* Scoping Documents

- E-1* Scoping Report Liberty Development and Production Plan
- E-2* Liberty Information Update Meetings

F* MMS-Sponsored Environmental Studies

G* Preliminary Section 404(b)(1) Evaluation - Liberty Development Project

H* Evaluation of Proposed Liberty Project Ocean Disposal Sites for Dredged Material at Foggy Island Bay

I EIS Documents Prepared by EPA

- I-1* BPXA's Liberty Island Oil and Gas Development Project Fact Sheet
- I-2 BPXA's Liberty Island Oil and Gas Development Project NPDES Proposed Final Permit AK-005314-7 and Responses to Public Comments on the Issuance of NPDES Permit No. AD-005314-7
- I-3* Ocean Discharge Criteria Evaluation - in Support of the Liberty Development Project NPDES Permit Application (URS Greiner Woodward Clyde, 1998)

J* EIS Reports Prepared by USGS and FWS

- J-1* Estimating Potential Effects of Hypothetical Oil-Spills from the Liberty Oil Production Island on Polar Bears
- J-2* Exposure of Birds to Potential Oil Spills at the Liberty Project

K	Summary of Effects of BPXA's Oil Discharge Prevention and Contingency Plan
L	Draft EIS Commenters
M	Federal, State, and Local Permits and Authorizations

*These appendices were published as part of the Liberty Development and Production Plan (DPP) Draft Environmental Impact Statement (DEIS) and were not revised for the Final EIS. The reader is referred to these appendices in the Draft EIS. These appendices are also available on the CD-ROM (MMS 2002-019 CD) and on the Internet (<http://www.mms.gov/alaska/cproject/liberty>).

**This appendix is available on the CD-ROM (MMS 2002-019 CD) and on the Internet (<http://www.mms.gov/alaska/cproject/liberty>).

APPENDIX A

OIL-SPILL-RISK ANALYSIS

Appendix A Oil-Spill-Risk-Analysis

A. THE INFORMATION AND ASSUMPTIONS WE USE TO ANALYZE THE EFFECTS OF OIL SPILLS IN THIS EIS

We analyze oil spills and their relative impact to environmental, economic and sociocultural resource areas and the coastline that could result from offshore oil development at Liberty. Predicting an oil spill is an exercise in probability. Uncertainty exists regarding the location, number, and size of spills and the wind, ice and current conditions at the time of a spill. Although some of the uncertainty reflects incomplete or imperfect data, a considerable amount of uncertainty exists simply because it is difficult to predict events 15-20 years into the future.

We make assumptions to analyze the effects of oil spills. To judge the effect of an oil spill, we estimate information regarding the type of oil, the source, the location and size of a spill, the chemistry of the oil, how the oil will weather, how long it will remain, and where it will go. We describe the rationale for these assumptions in the following subsections. The rationale for these assumptions is a mixture of project-specific information, modeling results, statistical analysis, and professional judgement. Based on these assumptions, we assume one spill occurs and then analyze its effects. After we analyze the effects of an oil spill, we consider the chance of an oil spill ever occurring.

1. Estimates of the Source, Type, and Size of Oil Spills

Tables A-1 and A-2 show the source of spill, type of oil, size of spill(s) in barrels, and the receiving environment we assume in our analysis of the effects of oil spills in this EIS for the Proposal and Alternatives and other analyses. We divide spills into small, large, and very large spills. Small spills are those less than 500 barrels. Large spills are greater than or equal to 500 barrels, and very large spills are greater than or equal to 150,000 barrels. Table A-1 shows

the EIS section where we analyze the effects of a large, small, and very large spill.

We use several sources of information for our assumptions about spill size but place special emphasis on the following:

- project-specific engineering calculations for response-planning standards,
- Alaska North Slope crude and refined oil-spill history, and
- project-specific engineering calculations for pipeline system alternatives.

The precision of the engineering calculations from the above studies does not express the uncertainty associated with our estimating the size of an oil spill that might occur 15-20 years into the future. Typically, we would round the assumed spill volume to the nearest hundred or thousand to represent the uncertainty in our estimating a spill size that could occur over the 15-20-year life of the project. For the Liberty Project where engineering calculations are made, we have kept the exact calculation to maintain consistency between documents related to the project.

In this EIS, we analyze what is likely to happen in the future. We must make some assumptions about the likely size of a spill to analyze the effects. To estimate the above spill sizes, we use the following sources of information and rationale.

a. BPXA's Oil Discharge Prevention and Contingency Plan

We first determine if BPXA's estimates of greatest possible discharge for the State of Alaska's response-planning standards are likely spill sizes. If the estimates fall into the likely spill-size category, we analyze that size. If the estimates do not fall into the likely spill-size category, we determine a likely spill size to analyze.

Section II.A.4 summarizes BPXA's estimates of the greatest possible discharge and the response scenarios outlined in BPXA's *Oil Discharge Prevention and Contingency Plan, Liberty Development Area, North Slope, Alaska* (BPXA, 2000b); a revised *Oil Discharge Prevention and*

Contingency Plan was submitted in November 2001 (BPXA, 2001). The State of Alaska requires this estimate for a response-planning standard under 18 AAC 75.430. A company must demonstrate the general procedure for cleaning up a discharge of that size. BPXA's spill-size estimates for offshore and onshore pipelines and diesel tanks fall into the likely spill-size category. This is based on median spill sizes for both the outer continental shelf (Anderson and LaBelle, 2000) and the Alaskan North Slope (Table A-3). BPXA's spill-size estimate for offshore pipelines assumes the Leak Location and Detection System (LEOS) is working.

The revised *Oil Discharge Prevention and Contingency Plan* prohibits the drilling of new wells or sidetracks from existing wells into major liquid-hydrocarbon zones at its drill sites during the defined period of broken ice and open water (BPXA, 2001:Section 2.1.7). This period begins on June 13 of each year and ends with the presence of 18 inches of continuous ice cover for one-half mile in all directions from the Liberty island. This drilling moratorium eliminates the environmental effects associated with a well blowout during drilling operations in the Beaufort Sea during broken-ice or open-water conditions.

BPXA's response-planning standard for a blowout from the Liberty gravel island is 178,800 barrels. That estimate does not fall into the likely spill-size category. The median spill size for a platform on the outer continental shelf is 7,000 barrels, and the average is 18,300 barrels (Anderson and LaBelle, 2000). The largest blowout to occur on the outer continental shelf was the 80,000-barrel Santa Barbara spill in 1969. Since 1980, no spills greater than or equal to 1,000 barrels have occurred from outer continental shelf platforms. A 178,800-barrel spill is 25 times the median platform spill size and 13 times the average platform spill size. It is 98,000 barrels larger than the largest platform spill on the outer continental shelf.

The record for Alaska North Slope blowouts is not validated, but is presented as the best available information. The State does not maintain a database of North Slope well-control incidents. The Alaska Oil and Gas Conservation Commission maintains an internal documentation of blowouts in Alaska. Neither of the following authors were allowed to review the documentation. The Alaska Oil and Gas Conservation Commission assured Fairweather that they had not overlooked any blowouts.

There are two written reports regarding blowouts on the Alaska North Slope, Mallory (1998) and Fairweather (2000). Mallory (1998) presents the following data based on discussions with long-time Alaska drilling personnel in ARCO Alaska or BPXA. In the period 1974-1997, an estimated 3,336 wells were drilled on Alaska's North Slope. Research conducted to date documented six cases of loss of secondary well control with a drilling rig on the well. These wells were not differentiated between exploration and

development wells. No oil spills, fires, or loss of life occurred in any of the events (Mallory, 1998).

Fairweather (2000) differentiated between a blowout and a well control incident. A blowout was defined as an uncontrolled flow at the surface of liquids and/or gas from the wellbore resulting from human error and/or equipment failure. Fairweather (2000) found 10 blowouts, 6 that Mallory had identified and 4 prior to 1974. Of the 10 blowouts, 9 were gas and 1 was oil. The blowout of oil in 1950 was unspectacular and could not have been avoided, as there were no casings of blowout preventors available (Fairweather, 2000). These drilling practices from 1950 would not be relevant today. A third study confirmed that no crude oil spills greater than or equal to 100 barrels from blowouts occurred from 1985-1999 (Hart Crowser, Inc., 2000). The record for oil spills from blowouts less than 100 barrels was not been searched by Hart Crowser Inc.

A recent report titled *Blowout Frequency Assessment of Northstar* (Scanpower, 2001) uses statistical blowout frequencies modified to reflect specific field conditions and operative systems at Northstar. This report concludes that the blowout frequency for drilling the oil-bearing zone is 1.5×10^{-5} per well drilled. This compares to a statistical blowout frequency of 7.4×10^{-5} per well (for an average development well). This same report estimates that the frequency of oil quantities per well drilled for Northstar for a spill greater than 130,000 barrels is 9.4×10^{-7} per well. Similar estimates can be extrapolated to Liberty, although there are some differences in reservoir characteristics.

Because a blowout at the gravel island is a significant concern to the public, we analyze the effects of a 180,000-barrel spill in Section IX, Low Probability, Very Large Oil Spill.

b. Analysis of Offshore Pipeline Spills Assuming LEOS is Operational

Section II.A.1.b(3)(d), Offshore Pipeline Damage and Oil Spills, describes the engineering information on the size of oil spills from offshore pipeline damage assuming LEOS is operational. For purposes of analysis, we consider a leak of 125 barrels and a rupture of 1,580 barrels (INTEC, 2000).

c. Analysis of Offshore Pipeline Spills Assuming LEOS is Not Operational

We also consider what spill sizes might occur if LEOS is not operational. In the original oil discharge prevention and contingency plan for Liberty (BPXA, 1999, 4/99, Rev 0), BPXA's estimate of worst-case response-planning standard was 1,845 barrels for 7 days during open water and 4,086 barrels for 30 days during full ice cover. These were calculated with the following parameters: 97.5 barrels per

day before detection; 2.3 barrels for reaction time; 29 barrels for expansion; and 1,130 barrels for drainage.

In the calculation for a leak of 125 barrels under the LEOS system, INTEC (2000) assumes that oil loss due to water intrusion is minimal because of the pinhole size of the leak. A small crack or pinhole leak would not allow drainage. For purposes of analysis, we apply this same assumption to the pipeline spill-size calculation. If the hole were to enlarge to allow more than 97.5 barrels per day to escape, then the pressure-point analysis/mass-balance line-pack compensation systems would detect the spill.

We assume the offshore pipeline spill sizes without drainage are 715 and 2,956 barrels. To calculate the pipeline spill sizes, we assume that the reaction loss is 2.3 barrels and the expansion loss is 29 barrels (BPXA, 1999, 4/99, Rev 0). For the 715-barrel spill, we assume it takes 7 days to detect a 97.5-barrel-a-day spill and add reaction and expansion loss. For the 2,956-barrel spill, we assume it takes 30 days to detect a 97.5-barrel-a-day spill and add reaction and expansion loss.

d. Historical Crude Oil Spills Greater Than or Equal to 100 Barrels on the Alaska North Slope

Because we believe 180,000 barrels is not a likely spill size from an offshore gravel island facility, we must use other information to identify a likely spill size. We look at the record of historical spills of Alaska North Slope crude oil to determine what is a likely spill size for facilities on the Alaska North Slope.

For the Alaska North Slope, we obtained and collated all available information on historic spills greater than or equal to 100 barrels from 1968-2000 from industry and regulatory agencies (Hart Crowser, Inc., 2000 and Anderson and LaBelle, 2000). For the Alaska North Slope, MMS and Hart Crowser collected data for crude oil spills from the U.S. Beaufort Sea, the National Petroleum Reserve-Alaska, and Alaska Onshore North Slope, east of the National Petroleum Reserve-Alaska from the following sources:

- BP electronic database files of oil spills in the Prudhoe Bay Unit Western Operating Area (1989 through 1996), Duck Island (Endicott) Unit (1989 through 1996), and Milne Point (1994 through 1996).
- ARCO electronic spreadsheet files of oil spills for the Prudhoe Bay Unit Eastern Operating Area (1977 through 1996), Kuparuk River Unit (1977 through 1985 and 1986 through 1996), and Kuparuk River Unit exploration (1986 through 1996).
- Alyeska printed summary report of oil spills greater than 1,000 barrels along the Trans-Alaska Pipeline System from 1977-1989.

- Joint Pipeline Office electronic database of oil spills along the Trans-Alaska Pipeline System (TAPS) (1970 through 1994).
- Bureau of Land Management printed reports of oil spills along the TAPS during 1981 and 1982.
- State of Alaska, Department of Environmental Conservation electronic text and spreadsheet files of oil spills from the agency's current oil and hazardous substances spill database (July 1995-February 1997) and an earlier oil and hazardous substances spill database (1971-July 1995).
- An unattributed printed summary of oil spills over 378.5 liters (100 gallons) on Alaska's North Slope and along the TAPS from 1970-1981.
- An electronic spreadsheet summary of Alaskan and Canadian oil spills of 100 barrels or greater, from 1978 through 1997, as reported by the *Oil Spill Intelligence Report*.
- An MMS report that no oil spills of 100 barrels or larger have occurred in the Alaska Outer Continental Shelf Beaufort or Chukchi sea study area.
- Alyeska; an electronic spreadsheet file containing all oil spills of 100 barrels and greater from the company's oil-spill database to September 1999.
- State of Alaska, Department of Environmental Conservation electronic spreadsheet containing all oil spills in their current oil and hazardous substance spill database to December 2000.
- BPXA electronic spreadsheet containing all Industry and contractor oil spills from January 1997-to May 2001.
- Additional oil-spill data were not received in response to inquiries and requests made by Hart Crowser to the Environmental Protection Agency, Bureau of Land Management, or the National Response Center.

The Alaska North Slope oil-spill analysis includes onshore oil and gas exploration and development spills from the Point Thompson Unit, Badami Unit, Kuparuk River Unit, Milne Point Unit, Prudhoe Bay West Operating Area, Prudhoe Bay East Operating Area, and offshore Duck Island Unit (Endicott). The Alaska North Slope data include spills from onshore pipelines and offshore and onshore facilities. The following information does not include spills on the Alaska North Slope from the TAPS. These were evaluated separately.

We reviewed the reliability and completeness of the data for spills greater than or equal to 500 barrels. We determined that the available information was most reliable for the period 1985-2000 based on written documentation or lack of documentation and spills before that period. The MMS determined that spills greater than or equal to 100 barrels were documented and included in the database since 1985. The year 1985 was when the State of Alaska, Department of Environmental Conservation began keeping track of spills in an electronic format. Although Hart Crowser (2000) states that the database is complete since production began, MMS

prefers to use the starting period of reliability of the data as 1985. We believe the lack of documentation of spills prior to that time is a concern because typically spills occur more frequently during field and pipeline startup.

We identify six crude oil spills greater than or equal to 500 barrels associated with onshore Alaska North Slope oil production for the time period 1985-2000. The six spills are listed below and in Table A-27c:

- July 28, 1989: 925 barrels from a facility tank leak; Conoco's Milne Point Unit Central Processing Facility.
- August 25, 1989: 510 barrels from a pipeline leak; ARCO Alaska's Kuparuk River Unit, Drill Site 2-U (additional 90 barrels of produced water spilled).
- December 10, 1990: 600 barrels from a facility explosion; ARCO Alaska's Lisburne Unit Drill Site L-5.
- August 17, 1993: 675 barrels resulting from tank corrosion; ARCO Alaska's Kuparuk River Unit Central Processing Facility 1 (an additional 75 barrels of produced water spilled).
- September 26, 1993: 650 barrels from a facility tank leak; BPXA Prudhoe Bay Unit.
- August 21, 2000: 715 barrels from a facility tank leak, BPXA, Prudhoe Bay Unit, Gathering Center 2.

All of the crude oil spills of 500 barrels or greater occurred between 1989 and 2000. We found no spills greater than or equal to 1,000 barrels. Of the six spills, one spill, which we classify as a pipeline spill, was a leak from either a 20- or 24-inch flow line that carries product from the drill sites in Kuparuk to the Central Processing Facility. The other five spills we classify as facility spills.

For the period 1985-2000, the median facility spill greater than or equal to 500 barrels on the Alaskan North Slope is 663 barrels, and the average is 680 barrels. There is one pipeline spill in the database. The volume of the pipeline spill was 510 barrels. For purposes of analysis, we use the largest spill in the record for a facility spill and assume this is equivalent to a spill size from the Liberty gravel island facilities. The largest facility spill in the record is 925 barrels.

e. Historical Crude Oil Spills Greater Than or Equal to 1,000 Barrels on the Outer Continental Shelf

The median size of a crude oil spill greater than or equal to 1,000 barrels from a pipeline over the entire record from 1964-1999 on the outer continental shelf is 5,100 barrels, and the average is 16,600 barrels (; Anderson and LaBelle, 2000). The median spill size for a platform on the outer continental shelf over the entire record from 1964-1999 is 7,000 barrels, and the average is 18,300 barrels (Anderson and LaBelle, 2000). We use the median outer continental shelf spill sizes to help us determine if a spill size falls into

the likely category. For example, the estimated 180,000-barrel spill from the gravel island was compared to the median spill size for an outer continental shelf platform and determined not to be a likely spill size.

f. Historical Crude and Product Oil Spills Greater Than or Equal to 1,000 Barrels from Onshore Pipelines

Analysis of historical datasets for onshore pipelines includes the Alaska North Slope as described above, Conservation of Clean Air and Water in Europe (CONCAWE) Oil Pipelines Management Group, Department of Transportation Office of Pipeline Safety, and the Trans-Alaska Pipeline. For the CONCAWE data, the median spill size of a crude and petroleum product oil spill greater than or equal to 1,000 barrels from an onshore pipeline over the entire record from 1971-1999 is 1,950 barrels, and the average is 3,700 barrels. For onshore U.S. pipelines, the median spill size of a crude and petroleum product oil spill greater than or equal to 1,000 barrels from an onshore pipeline over the record from 1986-2000 is 2,400 barrels, and the average is 4,300 barrels. For the onshore Trans-Alaska Pipeline, the average is 3,500 and median spill size of a crude oil spill greater than or equal to 1,000 barrels over the record from 1977-2000 is 3,200 barrels. No spills greater than or equal to 1,000 barrels have occurred from 1981 to 2000 from the Trans-Alaska Pipeline. On October 4, 2001, a bullet punctured the Trans-Alaska Pipeline. Approximately 6,800 barrels of crude oil were released. This spill is not included in this analysis. It will be added at the end of the calendar year, when yearly production data are tabulated.

The median spill sizes range from 1,950-200 barrels (Table A-3). These median spill sizes help us determine that a 1,580 and a 2,956 barrel pipeline spill are likely spill sizes. The assumed spill sizes are close to or within the range of median spill sizes that have occurred historically.

2. Behavior and Fate of Liberty Crude Oil

Several processes alter the chemical and physical characteristics and toxicity of spilled oil. Collectively, these processes are referred to as weathering or aging of the oil and, along with the physical oceanography and meteorology, the weathering processes determine the oil's fate. The major oil-weathering processes are spreading, evaporation, dispersion, dissolution, emulsification, microbial degradation, photochemical oxidation and sedimentation to the seafloor or stranding on the shoreline (Payne et al., 1987; Boehm, 1987).

The physical properties of a crude oil spill, the environment it occurs in, and the source and rate of the spill will affect how an oil spill behaves and weathers. Table A-4 shows the

properties of the Liberty crude oil based on a sample from an initial 2,000 barrels produced. Liberty crude oil is a waxy medium- to heavy-gravity crude. It has a moderately high viscosity and a high pour point for Alaska North Slope crude oils (S.L. Ross, 2000). On the Alaska North Slope, Endicott crude oil has the most similar properties to Liberty, but is still significantly different.

The environment in which a spill occurs, such as the water surface or subsurface, spring ice-overflow, summer open-water, winter under ice, or winter broken ice, will affect how the spill behaves. In ice-covered waters, many of the same weathering processes are in effect; however, the sea ice changes the rates and relative importance of these processes (Payne, McNabb, and Clayton, 1991).

Oil spills spread less in cold water than in temperate water because of the increased oil viscosity. The pour point of Liberty crude oil is 3 degrees Celsius. This temperature will be above the ambient sea temperature at certain times of the year. This property will reduce spreading. An oil spill in broken ice would spread less and would spread between icefloes into any gaps greater than about 8-15 centimeters (Free, Cox, and Shultz, 1982).

An oil spill under ice would follow this sequence: (1) The oil will rise to the under-ice surface and spread laterally, accumulating in the under ice cavities (Glaeser and Vance 1971; NORCOR, 1975; Martin, 1979; Comfort et al., 1983). (2) For spills that occur when the ice sheet is still growing, the pooled oil will be encapsulated in the growing ice sheet (NORCOR, 1975; Keevisl and Ramseier, 1975; Buist and Dickens, 1983; Comfort et al., 1983). (3) In the spring as the ice begins to deteriorate, the encapsulated oil will rise to the surface through brine channels in the ice (NORCOR, 1975; Purves, 1978; Martin, 1979; Kisil, 1981; Dickins and Buist, 1981; Comfort et al., 1983). The spread of oil under the landfast ice may be affected by the presence of currents, if the magnitude of those currents are large enough. A field study near Cape Parry in the Northwest Territories reported currents up to 10 centimeters per second were present. This current was insufficient to strip oil from under the ice sheet after the oil had ceased to spread (NORCOR, 1975). Laboratory tests have shown that currents in excess of 15-25 centimeters per second are required to strip oil from under-ice depressions (Cammaert, 1980; Cox et al., 1980). Current speeds at Liberty generally are less than 10 centimeters per second during the winter (Weingartner and Okkonen, In press). The area of contamination for oil under ice could increase if the ice were to move. Because Liberty is in the landfast ice area, the spread of oil due to ice movement would not be anticipated until spring breakup.

The lower the temperature, the less crude oil evaporates. Both Prudhoe Bay and Endicott crudes have experimentally followed this pattern (Fingas, 1996). Oil between or on icefloes is subject to normal evaporation. Oil that is frozen into the underside of ice is unlikely to undergo any evaporation until its release in spring. In spring as the ice

sheet deteriorates, the encapsulated oil will rise to the surface through brine channels in the ice. For Liberty crude oil, the high pour point of the oil may slow migration through the brine channel. Rather than oil migrating to the surface, the ice may melt down to the oil (S.L. Ross, 2000). As oil is released to the surface, evaporation will occur.

Dispersion of oil spills occurs from wind, waves, currents, or ice. Any waves within the ice pack tend to pump oil onto the ice. Some additional oil dispersion occurs in dense, broken ice through floe-grinding action. More viscous and/or weathered crudes may adhere to porous icefloes, essentially concentrating oil within the floe field and limiting the oil dispersion. Liberty crude oil may not disperse readily due to its high viscosity at ambient temperatures (S.L. Ross, 2000).

Liberty crude oil will readily emulsify to form stable emulsions (S.L. Ross, 2000). Emulsification of some crude oils is increased in the presence of ice. With floe grinding, Prudhoe Bay crude forms a mousse within a few hours, an order of magnitude more rapidly than in open water.

a. Assumptions about Oil Weathering

- The crude oil properties will be similar to the original crude oil analyzed from Liberty by S.L. Ross (1998).
- The diesel oil properties will be similar to a typical arctic diesel.
- The size of the spill is 125; 715; 925; 1,580; or 2,956 barrels.
- The wind, wave, and temperature conditions are as described.
- Meltout spills occur into 50% ice cover.
- The properties predicted by the model are those of the thick part of the slick.

Uncertainties exist, such as:

- the actual size of the oil spill or spills, should they occur;
- wind, current, wave, and ice conditions at the time of a possible oil spill; and
- Liberty crude oil properties at the time of a possible spill.

b. Modeling Simulations of Oil Weathering

To judge the effect of an oil spill, we estimate information regarding how much oil evaporates, how much oil is dispersed and how much oil remains after a certain time period. We derive the weathering estimates of Liberty crude oil and arctic diesel from two sources. The first is a report by S.L. Ross (2000), the *Preliminary Evaluation of the Behavior and Cleanup of Liberty Crude Oil Spills in Arctic Water*. This report discusses the results of the S.L. Ross weathering model with a Liberty crude oil for up to 3 days. The second is modeling results from the SINTEF Oil

Weathering Model Version 1.8 (Reed et al., 2000) with a Liberty crude oil for up to 30 days.

Tables A-5 and A-6 show the results of each model. Table A-5 shows the results of weathering an instantaneous spill of 1,000 barrels of Liberty crude oil with the S.L. Ross Model for up to 3 days. The four environmental conditions are: spring breakup, winter ice, fall freezeup, and open water. The results for a 1,000-barrel spill in open water from the S.L. Ross model are very similar to the results for a 925-barrel spill in open water from the SINTEF model. The primary difference is that the dispersion rates are less in the S.L. Ross model. We incorporate the range of dispersion rates for 1 and 3 days from both models into our analysis.

Tables A-6a through A-6f show the individual weathering results for Liberty crude oil spills using the SINTEF model. The SINTEF OWM changes both oil properties and physical properties of the oil. The oil properties include density, viscosity, pour point, flash point, and water content. The physical processes include spreading, evaporation, oil-in-water dispersion, and water uptake. The SINTEF OWM Version 1.8 performs a 30-day time horizon on the model-weathering calculations, but with a warning that the model is not verified against experimental field data for more than 4 - 5 days. The SINTEF OWM has been tested extensively with results from three full-scale field trials of experimental oil spills (Daling and Strom, 1999).

The SINTEF OWM does not incorporate the effects of:

- currents;
- beaching;
- containment;
- photo-oxidation;
- microbiological degradation;
- adsorption to particles; and
- encapsulation by ice.

The Liberty crude oil spill sizes are 125, 715, 720, 925, 1,580, and 2,956 barrels and a diesel spill of 1,283 barrels. We simulate two general scenarios: one in which the oil spills into open water and one in which the oil freezes into the ice and melts out into 50% ice cover. We assume open water is July through September, and a winter spill melts out in July. For open water, we model the weathering of the 125- and 715-barrel spills as if they spill over a 24-hour period and the 925- and 1,580-barrel spills as instantaneous spills. For the meltout spill scenario, we model the entire spill volume as an instantaneous spill. Although different amounts of oil could melt out at different times, the MMS took the conservative approach, which was to assume all the oil was released at the same time. We report the results at the end of 1, 3, 10, and 30 days.

Tables A-7, A-8 and A-9 summarize the results we assume for the fate and behavior of Liberty crude oil and diesel oil in our analysis of the effects of oil on environmental and social resources. For Liberty crude oil, the evaporation and dispersion rates are less than the typical Alaska North Slope

crude. In general, more oil will remain through time. Liberty crude oil is a waxy oil with a moderate pour point that at certain times of the year can be above the ambient seawater temperature. The effect of these properties will cause the Liberty oil to gel and form a thick layer when the pour point is above the ambient seawater temperature. It will be harder for the oil to evaporate or disperse. For spills that start over longer periods of time, where the oil film is thinner, there may not be as much resistance to evaporation or dispersion.

3. Estimates of Where an Offshore Oil Spill May Go

We study how and where large offshore spills move by using a computer model called the Oil-Spill-Risk Analysis model (Smith et al., 1982). By large, we mean spills greater than or equal to 500 barrels. This model analyzes the likely paths of oil spills in relation to biological, physical, and social resources. The model uses information about the physical environment, including files of wind, ice, and current data. It also uses the locations of environmental resource areas, barrier islands, and the coast that might be contacted by a spill.

a. Inputs to the Oil-Spill-Trajectory Model

- study area
- seasons
- location of the coastline
- location of environmental resource areas
- location of land segments
- location of boundary segments
- location of proposed and alternative gravel islands
- location of proposed and alternative pipelines
- current and ice information from two general circulation models
- wind information

(1) Study Area

Map A-1 shows the Liberty oil-spill-trajectory study area extends from lat. 69° N. to 72.5° N. and from long. 138° W. to 157° W. We chose a study area large enough to contain the paths of 3,000 oil spills with 500 spilletes each through as long as 360 days.

(2) Seasons

We define two time periods for the trajectory analysis of oil spills. The first is from July through September and represents open water or arctic summer. We ran 1,500 trajectories in the arctic summer. The second is from October through June and represents ice cover or arctic winter. We also ran 1,500 trajectories in the arctic winter.

(3) Locations of Environmental Resource Areas

Maps A-2 and A-3 shows the location of 62 environmental resource areas, which represent concentrations of wildlife, subsistence-hunting areas, and subsurface habitats. Our analysts designate these environmental resource areas. The analysts also designate in which months these environmental resource areas are vulnerable to spills. The names or abbreviations of the environmental resource areas and their months in which they are vulnerable to spills are shown in Table A-10. We also include Land as an additional environmental resource area. Land is the entire study area coastline.

(4) Location of Land Segments

Land was further analyzed by dividing the Beaufort Sea coastline into 42 land segments. Map A-1 shows the location of these 43 land segments. Land Segments 6 through 19 and 32 through 43 are approximately 18.64 miles (30 kilometers) long. Land Segments 20 through 31 are closest to the Liberty Project and are approximately 12.43 miles (20 kilometers) long. Land segments are vulnerable to spills in both summer and winter. The model defines summer as July through September and winter from October through June. Maps A-4 and A-5 show how the Alaska Clean Seas Technical Manual Map Atlas Sheets correlate to our land segments and barrier island environmental resource areas.

(5) Location of Proposed and Alternative Gravel Islands

Map A-6 shows the location of the Liberty, Southern, and Tern gravel islands, the sites where large oil spills would originate, if they were to occur. Liberty gravel island is Alternative I and is abbreviated LI. The Liberty gravel island has an oval shape and is centered at 70°16'45.3556" N. and 147°33'29.0891" W. The Southern gravel island is Alternatives III.A and is abbreviated AP1. Tern gravel island is Alternative III.B and is abbreviated TI.

(6) Location of Proposed and Alternative Pipelines

Map A-6 shows the location of the proposed pipeline (PP1-PP2), eastern pipeline (AP1-AP2), and tern pipeline (TP1 and TP2). The Alternative I transportation scenario assumes that BPXA would transport oil from the Liberty gravel island (LI) to shore through a subsea pipeline with a landfall at approximately 1.5 miles (2.5 kilometers) west of the Kadleroshilik River. We use these route segments (PP1-PP2) to represent spills from the proposed pipeline: PP1 represents spills that occur further offshore, and PP2 represents spills that occur nearshore. The Alternative III.A pipeline scenario (AP1-AP2) assumes the pipeline would make landfall at approximately 2 miles (3.2 kilometers) east of the Kadleroshilik River. We use these route segments (AP1-AP2) to represent spills from the eastern alternative pipeline: AP1 represents spills that occur further offshore,

and AP2 represents spills that occur nearshore. The Alternative III.B pipeline scenario (TP1-TP2) assumes the pipeline would make landfall at approximately 2 miles (3.2 kilometers) east of the Kadleroshilik River. We use these route segments (TP1-TP2) to represent spills from the Tern Island alternative pipeline: TP1 represents spills that occur farther offshore, and TP2 represents spills that occur nearshore. An existing onshore pipeline from Badami and Endicott would transport oil to Pump Station 1 of the Trans-Alaska Pipeline System.

(7) Current and Ice Information from a General Circulation Model

For the Liberty Project we use two general circulation models to simulate currents (U_{current}) or ice (U_{ice}) depending upon whether the location is nearshore or offshore.

(a) Offshore

Offshore of the 10- to 20-meter bathymetry contour, the wind-driven and density-induced ocean-flow fields and the ice-motion fields are simulated using a three-dimensional coupled ice-ocean hydrodynamic model (Hedström, Haidvogel, and Signorini, 1995; Hedström, 1994). The model is based on the ocean model of Haidvogel Wilkin, and Young (1991) and the ice model of Hibler (1979). This model simulates flow properties and sea ice evolution in the western Arctic during the year 1983. The coupled system uses a semispectral primitive equation ocean circulation model and the Hibler sea ice model and is forced by daily surface geostrophic winds and monthly thermodynamic forces. The model is forced by thermal fields for the year 1983 (Prof. John Walsh, University of Illinois, as cited in Hedström, Haidvogel, and Signorini, 1995). The thermal fields are interpolated in time from monthly fields. The location of each trajectory at each time interval is used to select the appropriate ice concentration. The pack ice is simulated as it grows and melts. The edge of the pack ice is represented on the model grid. Depending on the ice concentration, either the ice or water velocity with wind drift from the stored results of the Haidvogel, Wilkin, and Young (1991) coupled ice-ocean model is used. A major assumption used in this analysis is that the ice-motion velocities and the ocean daily flows calculated by the coupled ice-ocean model adequately represent the flow components. Sensitivity tests and comparisons with data illustrate that the model captures the first-order transport and the dominant flow (Hedström, Haidvogel, and Signorini, 1995).

(b) Nearshore

Inshore of the 10- to 20-meter bathymetry contour, U_{current} is simulated using a two-dimensional hydrodynamic model developed by the National Oceanic and Atmospheric Administration (NOAA) (Galt, 1980, Galt and Payton, 1981). This model does not have an ice component. In this model, we added an ice mask within the 0-meter and 10- to

20-meter water-depth contours to simulate the observed shorefast-ice zone. We apply the mask from November 1- June 15. U_{ice} is zero for the months November through June. The two-dimensional model incorporated the barrier islands in addition to the coastline. The model of the shallow water is based on the wind forcing and the continuity equation. The model was originally developed to simulate wind-driven shallow water dynamics in lagoons and shallow coastal areas with a complex shoreline. The solutions are determined by a finite element model where the primary balance is between the wind forcing friction, the pressure gradients, coriolis accelerations, and the bottom friction. The time dependencies are considered small, and the solution is determined by iteration of the velocity and sea level equations, until the balanced solution is calculated. The wind is the primary forcing function, and a sea level boundary condition of no anomaly produced by the particular wind stress is applied far offshore, at the northern boundary of the oil spill trajectory analysis domain. An example of the currents simulated by this model for a 10-meter-per-second wind is shown in Figure A-1.

The results of the model were compared to current meter data from the Endicott Environmental Monitoring Program to determine if the model was simulating the first order transport and the dominant flow. The model simulation was similar to the current meter velocities during summer. Example time series from 1985 show the current flow at Endicott Station ED1 for the U (east-west) and V (north-south) components, plotted on the same axis with the current derived from the National Oceanographic and Atmospheric Administration model for U and V (Der-U and Der-V). The series show many events that coincide in time, and that the currents derived from the National Oceanic and Atmospheric Administration model are generally in good correspondence with the measured currents. Some of the events in the measured currents are not particularly well represented, and that probably is due to forcing of the current by something other than wind, such as low frequency alongshore wave motions.

(8) Wind Information

We use the 17-year reanalysis of the wind fields provided to us by Rutgers. The TIROS Operational Vertical Sounder (TOVS) has flown on NOAA polar-orbiting satellites since 1978. Available from July 7, 1979, through December 31, 1996, and stored in Hierarchical Data Format, the TOVS Pathfinder (Path-P) dataset provides observations of areas poleward of lat. 60° N. at a resolution of approximately 100 x 100 kilometers. The TOVS Path-P data were obtained using a modified version of the Improved Initialization Inversion Algorithm (3I) (Chedin et al., 1985), a physical-statistical retrieval method improved for use in identifying geophysical variables in snow- and ice-covered areas (Francis, 1994). Designed to address the particular needs of the polar research community, the dataset is centered on the North Pole and has been gridded using an equal-area

azimuthal projection, a version of the Equal-Area Scalable Earth-Grid (EASE-Grid) (Armstrong and Brodzik, 1995).

Preparation of a basin-wide set of surface-forcing fields for the years 1980 through 1996 has been completed. (Francis, 1999). Improved atmospheric forcing fields were obtained by using the bulk boundary-layer stratification derived from the TOVS temperature profiles to correct the 10-meter level geostrophic winds computed from the National Center for Environmental Prediction Reanalysis surface pressure fields. These winds are compared to observations from field experiments and coastal stations in the Arctic Basin and have an accuracy of approximately 10% in magnitude and 20 degrees in direction.

(9) Oil-Spill Scenario

For purposes of this trajectory simulation, all spills occur instantaneously. For each trajectory simulation, the start time for the first trajectory was the first day of the season (summer or winter) of the first year of wind data (1980) at 6 a.m. Greenwich Mean Time. We launch particles every 1 day (on average) for each of the 17 years of wind.

b. Oil-Spill-Trajectory Model Assumptions

- The gravel island and pipelines are constructed in the locations proposed.
- BPXA transports the produced oil through the pipeline.
- An oil spill reaches the water.
- An oil spill encapsulated in the fast ice does not move until the ice moves or it melts out.
- Spreading is simulated through the dispersion of 500 spilletes in the model.
- Oil spills occur and move without consideration of weathering. The oil spills are simulated as 500 spilletes each as a point with no mass or volume. The weathering of the oil is estimated in the stand alone SINTEF OWM model.
- Oil spills occur and move without any cleanup. The model does not simulate cleanup scenarios. The oil-spill trajectories move as though no booms, skimmers, or any other response action is taken. The effect of the oil discharge prevention and contingency plan (BPXA, 2000) is analyzed in Sections III.C.2 and Section VII.
- Oil spills stop when they contact the mainland coastline, but not the barrier islands.

Uncertainties exist, such as:

- the actual size of the oil spill or spills, should they occur;
- whether the spill reaches the water;
- whether the spill is instantaneous or a long-term leak;
- the wind, current, and ice conditions at the time of a possible oil spill;
- how effective cleanup is;

- the characteristics of Liberty crude oil at the time of the spill;
- how Liberty crude oil will spread; and
- whether or not production occurs

c. Oil-Spill-Trajectory Simulation

The trajectory simulation portion of the model consists of many hypothetical oil-spill trajectories that collectively represent the mean surface transport and the variability of the surface transport as a function of time and space. The trajectories represent the Lagrangian motion that a particle on the surface might take under given wind, ice, and ocean current conditions. Multiple trajectories and spilletes are simulated to give a statistical representation, over time and space, of possible transport under the range of wind, ice, and ocean current conditions that exist in the area.

Trajectories are constructed from simulations of wind-driven and density-induced ocean flow fields, and the ice-motion field. The basic approach is to simulate these time and spatially dependent currents separately, then combine them through linear superposition to produce an oil-transport vector. This vector is then used to create a trajectory. Simulations are performed for two seasons: winter (October-June) and summer (July-September). The choice of this seasonal division was based on meteorological, climatological, and biological cycles and consultation with Alaska Region analysts.

For cases where the ice concentration is below 80%, each trajectory is constructed using vector addition of the ocean current field and 3.5% of the instantaneous wind field—a method based on work done by Huang and Monastero (1982), Smith et al. (1982), and Stolzenbach et al. (1977). For cases where the ice concentration is 80% or greater, the model ice velocity is used to transport the oil. Equations 1 and 2 show the components of motion that are simulated and used to describe the oil transport for each spillete:

$$1 \quad U_{oil} = U_{current} + 0.035 U_{wind}$$

or

$$2 \quad U_{oil} = U_{ice}$$

where:

U_{oil} = oil drift vector

$U_{current}$ = current vector (when ice concentration is less than 80%)

U_{wind} = wind speed at 10 meters above the sea surface

U_{ice} = ice vector (when ice concentration is greater than or equal to 80%)

The wind drift factor was estimated to be 0.035, with a variable drift angle ranging from 0° to 25° clockwise. The drift angle was computed as a function of wind speed according to the formula in Samuels, Huang, and Amstutz (1982). (The drift angle is inversely related to wind speed.)

The trajectories age while they are in the water and/or on the ice. For each day that the hypothetical spill is in the water,

the spill ages—up to a total of 360 days. While the spill is in the ice (greater than or equal to 80% concentration), the aging process is suspended. The maximum time allowed for the transport of oil in the ice is 360 days, after which the trajectory is terminated. When in open water, the trajectory ages to a maximum of 30 days.

Turbulent Diffusion of the Lagrangian Elements: The spilletes are assumed to move with U_{oil} as described above and to diffuse as a result of a random process. A random vector component typically is added to represent subgrid scale uncertainty associated with turbulence or mixing processes that are not resolved by the physical transport processes of the general circulation model.

d. Results of the Oil-Spill-Trajectory Model Assuming Oil Spills Occur from the Liberty Project

(1) Conditional Probabilities: Definition and Application

The chance that an oil spill will contact a specific environmental resource area or land or boundary segment within a given time of travel from a certain location or spill site is termed a conditional probability. The condition is that we assume a spill occurs. Conditional probabilities assume a spill has occurred and the transport of the spilled oil depends only on the winds, ice, and ocean currents in the study area.

For Liberty, we estimate conditional probabilities of contact within 1, 3, 10, 30, 60, or 360 days during summer. Summer spills are spills that begin in July through September. Therefore, if any contact to an environmental resource area or land segment is made by a trajectory that began before the end of September, it is considered a *summer contact* and is counted along with the rest of the contacts from spills launched in the summer. We also estimate the conditional probability of contact from spills that start in winter, freeze into the ice and meltout in the spring. We estimate contacts from these spills for 1, 3, 10, 30, 60, or 360 days. Winter spills are spills that begin in October through June melt out of the ice and contact during the open-water period. Therefore, if any contact to an environmental resource area or land segment is made by a trajectory that began by the end of June, it is considered a *winter contact* and is counted along with the rest of the contacts from spills launched in the winter.

(2) Conditional Probabilities: Results

Table A-11 shows the name of the location where we start a hypothetical spill from the gravel island or pipeline for Alternatives I, IIIA, III.B., IV.A, IV.B, IV.C., V, VI, and VII. Tables A-12 through A-27 give the conditional probabilities (expressed as percent chance) than an oil spill

starting at a particular location in the winter or summer season will contact certain environmental resource areas or land segments within 1, 3, 10, 30, 60, or 360 days from Liberty Island (LI), Southern Island (API), Tern Island (TI), Proposed Pipeline (PP1 and PP2), Eastern Alternative Pipeline (AP1 and AP2), and Tern Island Alternative Pipeline (TP1 and TP2). Conditional probabilities were rounded from one significant figure beyond the decimal point.

(a) Comparisons between Spill Location

In general, there are 0-2% differences in the chance of contact to the majority of the environmental resource areas when we compare Liberty Island (LI), Southern Island (API), and Tern Island to each other. Each of these islands are within 1.2-1.4 miles of each other, and there are no geographic barriers to spills between these island locations. The 3-12 percentage differences in the chance of contact are to resources directly adjacent to the area where we started the spill. For example, the largest difference (12%) is to the water surface over the Boulder Patch, because LI is directly adjacent to it and AP1 and TI are slightly farther away. In conclusion, changing the location of the island has an insignificant change in the chance of oil spill contact to the majority of the environmental resource areas.

In general there, are 0-2% differences in the chance of contact to the majority of the land segments when we compare Liberty Island (LI), Southern Island (API), and Tern Island to each other. Land Segment 26 has a 3-4% difference in the chance of contact from AP1 or TI when we compare them to LI. Changing the location of the island has insignificant changes in the chance of contact to the land segments.

(b) Generalities Through Time

1 Day: Within 24 hours, spills starting during summer from Liberty Island, Southern Island, Tern Island, proposed pipeline, eastern pipeline, and Tern pipeline have a chance of contact to Land Segments 25 through 28 ranging from 1-46%. The nearshore hypothetical spill sites have the higher chances of contact to shore. The proposed alternative islands and their associated pipelines are close to shore, and it is intuitively understandable that spills have a chance of contact to the adjacent coastline. The environmental resource areas with the highest chance of contact are within a 10-mile radius. The three barrier islands with the highest chance of contact ranging from 1-14% are the McClure Islands, Tigvariak Island, and the Endicott Causeway.

Within 24 hours, spills starting during winter from Liberty Island, Southern Island, Tern Island, proposed pipeline, eastern pipeline, and Tern pipeline have a chance of contact to Land Segments 25 through 26 ranging from less than 0.5-5%. The nearshore hypothetical spill sites have the higher chances of contact to shore. The proposed alternative islands and their associated pipelines are close to shore, and

it is intuitively understandable that spills have a chance of contact to the adjacent coastline. The environmental resource areas with the highest chance of contact are within a 5-mile radius. The three barrier islands, McClure Islands, Tigvariak Island, and the Endicott Causeway each have a 1% chance of contact.

3-10 Days: By 3-10 days, spills starting during summer from Liberty Island, Southern Island, Tern Island, proposed pipeline, eastern pipeline, and Tern pipeline have a chance of contacting additional Land Segments 21-24 and 29-34 ranging from less than 0.5-5%. The highest chance of contact is to Land Segments 25-28 and ranges from 1-55%. Most of the chance of contact to land segments is within 10 days, because there are only small percentage increases between 10 and 30 days. The highest chance of contact to environmental resource areas is within a 15-mile radius and ranges from 13-60%.

By 3-10 days, spills starting during winter from Liberty Island, Southern Island, Tern Island, proposed pipeline, eastern pipeline, and Tern pipeline have a chance of contact to Land Segments 25 through 26 ranging from 1-7%. Additional Land Segments 23, 27, and 28 have a less than 0.5-1% chance of contact. The nearshore hypothetical spill sites have the higher (4-7%) chances of contact to shore. The environmental resource areas with the highest (4-7%) chance of contact are within a 5-mile radius. The exception to this is Environmental Resource Area 33, which is directly adjacent to TI. Environmental Resource Area 35 has a 33% chance of contact within 1-10 days from TI during winter.

30 Days: By 30 days, the path of spills starting during summer from Liberty Island, Southern Island, Tern Island, proposed pipeline, eastern pipeline, and Tern pipeline extends farther down the coast away from the hypothetical spill sites. By 30 days, additional Land Segments 19, 20, 33 and 34 have a chance of contact of 1-2%. These land segments are approximately 80-125 kilometers and 114-170 kilometers to the west and east, respectively. The highest chance of contact to environmental resource areas is within a 30-mile radius and ranges from 13-60%.

By 30 days, spills starting during winter from Liberty Island, Southern Island, Tern Island, proposed pipeline, eastern pipeline, and Tern pipeline have a chance of contact to Land Segments 25 through 26 ranging from 1-10%. Additional Land Segments 22, 23, 24, 27, 28, and 29 have a less than 0.5-2% chance of contact. The environmental resource areas with the highest (8-11%) chance of contact are within a 5-mile radius. The exceptions to this are Environmental Resource Areas 35 and 36, which are directly adjacent to TI and TP2, respectively. Environmental Resource Areas 35 and 36 each have a 33% chance of contact within 30 days from TI or TP2 during winter.

4. Using Historical Spill Records to Estimate the Chance of an Oil Spill Occurring

We conclude that the designs for the Liberty Project will produce minimal chance of a large oil spill reaching the water. If an estimate of chance must be given for the offshore production island and the buried pipeline, our best professional judgment is that the chance of an oil spill greater than or equal to 500 barrels from the Liberty offshore project entering the offshore waters is on the order of 1%.

The reader is referred to Section III.C.1.d for a discussion on using historical spill records to estimate the chance of an oil spill occurring. This section evaluates the estimates of the chance of an oil spill occurring, using historical spill records and the oil-spill prevention designed into the Liberty Project. The exposure variables used are either volume of oil produced or pipeline miles or well years. None of these exposure variables will produce differences in spill occurrence between any of the alternative pipeline designs, because the pipeline design alternatives all are of similar length, or the same amount of oil will be produced regardless of pipeline design. Historical oil-spill data can be used to estimate the chance of an oil spill occurring, but they cannot be used to differentiate spill occurrence among the alternative pipeline designs. With the exception of the single-wall pipe, there are no historical oil-spill data for the alternative pipeline designs. The reader is referred to Table II.C-5 for information on engineering pipeline failure rates by pipeline design.

The following provides detailed information on the historical spill data including its location, period of time and exposure variable.

a. The MMS Outer Continental Shelf Spill Rate 1964-1999 Based on Volume

The U.S. outer continental shelf platform and pipeline spills greater than or equal to 1,000 barrels from 1964-1999 are shown in Tables 27a and 27b, respectively. There were 11 platform spills and 16 pipeline spills. Total U.S. outer continental shelf production from 1964-1999 was estimated to be 12.00 Bbbl crude oil and condensate (Anderson and LaBelle, 2000).

The spill rate of 0.32 spills per billion barrels handled for U.S. outer continental shelf pipeline spills greater than or equal to 1,000 barrels was based on adjustments using the last three spills that occurred over the most recent 9.5 billion barrels of production (Anderson and LaBelle, 2000). This is the same starting point from which the previous U.S. outer continental shelf platform spill rates were calculated (Anderson and LaBelle, 1990, 1994). The spill rate of 1.33 spills per billion barrels handled for U.S. outer continental

shelf pipeline spills greater than or equal to 1,000 barrels was calculated based on the entire record of 16 spills over 12.0 billion barrels of production.

Anderson and LaBelle (2000) calculated spill rates for the period 1985-1999. The rates are 0.13 spills per billion barrels handled for U.S. outer continental shelf platforms and 1.38 for U.S. outer continental shelf pipelines.

b. Alaska North Slope Spill Rate 1985-2000 Based on Volume

The Alaska North Slope facility and pipeline spills greater than or equal to 500 barrels from 1985-2000 are shown in Table A-27c. The Alaska North Slope pipelines do not include the Trans-Alaska Pipeline, which we analyze separately. No spills greater than 1,000 barrels from Alaska North Slope production have occurred since 1985. Prior to 1985, we have found no documentation for spills greater than 1,000 barrels but cannot validate that the spill records are complete before 1985 due to missing or incomplete documentation.

From 1985-2000, there are five facility spills and one pipeline spill. Total Alaska North Slope production was estimated to be 9.36 billion barrels of crude oil and condensate (Alyeska Pipeline Service Company, 2001; Banks, 2001; McMaines, 2001). Anderson and LaBelle (2000) calculated rates from 1985-1998 hence the slight differences.

The facility spill rate of 0.53 spills per billion barrels handled for Alaska North Slope facility spills greater than or equal to 500 barrels was based on the entire record of five spills from 1985-2000. The MMS uses this time period because we were able to document spills greater than 100 barrels since 1985 and were concerned with the lack of spills and documentation of any spills before that time. In addition, the State of Alaska, Department of Conservation began an electronic database of oil spills in 1985. The MMS considers the database most reliable from 1985 forward. The pipeline spill rate of 0.11 spills per billion barrels handled for Alaska North Slope facility spills greater than or equal to 500 barrels was based on the record of one spill from 1985-2000.

c. Trans Alaska Pipeline Spill Rate 1977-2000 Based on Volume and Mile-Year

The first flow in the Trans-Alaska Pipeline System began on June 20, 1977, with throughput of 112 million barrels by the end of 1977. Throughput increased to almost 400 million barrels in 1978, peaked at 744 million barrels in 1988, and was 366 million barrels in 2000. The estimated volume transported through the Trans-Alaska Pipeline from 1977-

2000 is 13.25 billion barrels. The Trans-Alaska Pipeline is 800.302 miles long.

The Trans-Alaska Pipeline crude oil spills greater than or equal to 500 barrels are shown in Table A-27d. There have been 11 crude oil spills (greater than or equal to 100 barrels) attributed to Trans-Alaska Pipeline operation, 4 of which were less than 500 barrels. Seven crude oil spills were greater than 500 barrels, of which six were greater than or equal to 1,000 barrels: We have excluded the spill caused by sabotage, because it was deliberate and we are looking at accidental causes of pipeline spills. The last spill greater than or equal to 1,000 barrels occurred in 1981. The spill rate of 0.38 spills per billion barrels transported for the Trans-Alaska Pipeline (spills greater than or equal to 1,000 barrels) was calculated based on the entire record of five spills over 13.25 billion barrels of production. The spill rate of 0.000265 spills per pipeline mile-year for the Trans-Alaska Pipeline (spills greater than or equal to 1,000 barrels) was calculated based on the entire record of five accidental spills over 18,835 pipeline mile-years from 1977-2000.

For purposes of analysis, we use the same time period and size class as the Alaska North Slope data. The time period is 1985-2000, and the class size is greater than or equal to 500 barrels. The spill rate of 0.11 spills per billion barrels transported for the Trans-Alaska Pipeline (spills greater than or equal to 500 barrels) was calculated based on the entire record of one spill over 9.36 billion barrels of production. The spill rate of 0.00007 spills per pipeline mile-year for the Trans-Alaska Pipeline (spills greater than or equal to 500 barrels) was calculated based on the entire record of one accidental spills over 12,805 pipeline mile-years from 1985-2000.

d. European Onshore Pipeline Spill Rate 1971-1995 Based on Volume and Mile-Year

The organization CONCAWE Oil Pipelines Management Group keeps track of European onshore pipeline spills. The CONCAWE has set a minimum spill size at 1 cubic meter, which is about 6 barrels. The Northstar final EIS (U.S. Army Corps of Engineers, 1999) uses the CONCAWE data and the time period 1991-1995. For purposes of analysis, MMS uses the same time period.

There were 17 crude and petroleum product spills (greater than or equal to 1,000 barrels) attributed to cross-country oil pipelines in Western Europe from 1991-1995 (Lyons, 1998). The spill rate of 0.00018 spills per pipeline mile-year of spills greater than or equal to 1,000 barrels was calculated based on the entire record of 96 spills 153,955 per pipeline mile-years from 1971-1999. During that same time period, 19.53 billion barrels of crude and petroleum products were transported for a spill rate of 0.87 spills per billion barrels transported.

There were 96 crude and petroleum product spills (greater than or equal to 1,000 barrels) attributed to cross-country oil pipelines in Western Europe from 1971-1999 (Lyons, 1998; Berry et al., 1997, 1998, 1999; and Davis et al., 2000). The long-term spill rate of 0.00024 spills per pipeline mile-year of spills greater than or equal to 1,000 barrels was calculated based on the entire record of 96 spills 400,801 per pipeline mile years from 1971-1999. During that same time period, 104 billion barrels of crude and petroleum products were transported for a spill rate of 0.92 spills per billion barrels transported.

Lyons (1998) reports significant progress over time in reducing the spill frequency per unit length of pipeline. The incidence of spills has dropped to a third of what it was in the 1970's. Davis et al. (2000) show that as the combined throughput from 1995-1999 has increased, the gross net spillage has followed a decreasing trend. Over the 29-year period from 1971-1999, the third-party activity category is the most frequent cause of spills (4.4 per year) and is easily the largest cause of oil loss into the environment (48%) from these Western European oil pipelines. Corrosion comes second in terms of the number of spillages (3.9 per year), and mechanical failure is second in terms of net volume spilled (28%) (Davis et al., 2000).

e. Outer Continental Shelf Spill Rate Based 1964-1993 on Mile-Year and Well-Year

S.L. Ross (1998) estimated the spill rate for outer continental shelf pipelines and platforms based on well-year and mile-year. During this time period, there were 11 platform spills and 13 pipeline spills. The spill rate of 0.000036 spills per well-year is calculated based on 97,921 well-years for the period 1971-1993. The rate is derived by converting from the spill rate based on volume produced. The conversion is completed by multiplying the average number of barrels produced per year. The spill rate of 0.00026 spills per pipeline-mile is calculated based on 43,000 pipeline mile-years for the period 1964-1991. A conversion factor is used to convert from spills per billion barrels transported to spills per pipeline mile.

f. U.S. Onshore Crude and Petroleum Product Pipeline Spill Rate 1986-2000 Based on Mile-Year

The U.S. Department of Transportation, Office of Pipeline Safety maintains information on Liquid Pipeline Operator Total National Mileage from 1986-2000 and distribution and transmission and incident data for the same time period. This information is posted to its web site (<http://ops.dot.gov>). The Office of Pipeline Safety requires pipeline systems to report, on DOT Form 7000-1, spills and other incidents that result in (1) explosion or fire, (2) loss of

50 or more barrels of hazardous liquid or carbon dioxide, (3) escape to the atmosphere of more than 5 barrels a day of highly volatile liquids, (4) death, (5) bodily harm such as loss of consciousness or the necessity for medical treatment, or (6) estimated property damage exceeding \$50,000.

This incident information was used to calculate spill rates for U.S. onshore crude and petroleum product pipelines. There were 527 crude and petroleum product pipeline spills greater than or equal to 1,000 barrels from 1986-2000. The spill rate of 0.00023 spills per pipeline mile year of spills greater than or equal to 1,000 barrels was calculated based on the entire record of 527 spills over 2,314,401 pipeline mile-years from 1986-2000.

B. SMALL OIL SPILLS

Small spills are spills that are less than 500 barrels. We analyze the effects of small spills in Section III.D.3. We consider two types of small spills. We assume one small spill of 125 barrels from the Liberty pipeline and 23 operational small spills totaling 68 barrels.

The analysis of operational small oil spills uses historical oil-spill databases and simple statistical methods to derive general information about small crude and refined oil spills that occur on the Alaska North Slope. This information includes estimates of how often a spill occurs for every billion barrels of oil produced (oil-spill rates), the mean (average) number of oil spills, and the mean and median size of oil spills from facilities, pipelines, and flowlines combined. We then use this information to estimate the number, size, and distribution of operational small spills that may occur from the Liberty Project. The analysis of operational small oil spills considers the entire production life of the Liberty Project and assumes:

- commercial quantities of hydrocarbons are present at Liberty, and
- these hydrocarbons will be developed and produced at the estimated resource levels.

Uncertainties exist, such as

- the estimates required for the assumed resource levels, or
- the actual size of a crude- or refined-oil spill.

We use the history of crude and refined oil spills reported to the State of Alaska, Department of Environmental Conservation and the Joint Pipeline Office to determine crude- and refined-oil spill rates and patterns from Alaska North Slope oil and gas exploration and development activities for spills greater than or equal to 1 gallon and less than 500 barrels. Refined oil includes aviation fuel, diesel fuel, engine lube, fuel oil, gasoline, grease, hydraulic oil, transformer oil, and transmission oil. The Alaska North Slope oil-spill analysis includes onshore oil and gas exploration and development spills from the Point Thompson Unit, Badami Unit, Kuparuk River Unit, Milne

Point Unit, Prudhoe Bay West Operating Area, Prudhoe Bay East Operating Area, and Duck Island Unit.

The Alaska North Slope oil-spill database of all spills greater than or equal to 1 gallon is from the State of Alaska, Department of Environmental Conservation. Oil-spill information is provided to the State of Alaska, Department of Environmental Conservation by private industry according to the State of Alaska Regulations 18 AAC 75. The totals are based on initial spill reports and may not contain updated information. The State of Alaska, Department of Environmental Conservation database integrity is most reliable for the period 1989-1998 due to increased scrutiny after the *Exxon Valdez* oil spill (Volt, 1997, pers. commun.). For this analysis, the database integrity cannot be validated thoroughly. However, we use this information, because it is the only information available to us about small spills. For this analysis, the State of Alaska, Department of Environmental Conservation database is spot checked against spill records from ARCO Alaska, Inc. and British Petroleum, Inc. All spills greater than or equal to 1 gallon are included in the dataset. We use the time period January 1989-December 1998 in this analysis of small oil spills for the Liberty Project.

A simple analysis of operational small oil-spills is performed. Alaska North Slope oil-spill rates are estimated without regard to differentiating operation processes. The State of Alaska, Department of Environmental Conservation database base structure does not facilitate quantitative analysis of Alaska North Slope oil-spill rates separately for platforms, pipelines, or flowlines.

1. Results for Small Operational Crude Oil Spills

The analysis of Alaska North Slope crude oil spills is performed collectively for all facilities, pipelines, and flowlines. Figure A-3 shows the size distribution of crude-oil spills greater than or equal to 1 gallon and less than 500 barrels from January 1989-December 1998 on the Alaska North Slope. The pattern of crude oil spills on the Alaska North Slope is one of numerous small spills. Of the crude oil spills that occurred between 1989 and 1998, 31% were less than or equal to 2 gallons; 55% were less than or equal to 5 gallons. Ninety-eight percent of the crude oil spills were less than 25 barrels and 99% were less than 60 barrels. The spill sizes in the database range from less than 1 gallon to 925 barrels. Only crude oil spills greater than or equal to 1 gallon are used in the analysis. The average crude oil-spill size on the Alaska North Slope is 2.7 barrels, and the median spill size is 5 gallons. For purposes of analysis, this EIS assumes an average crude oil-spill size of 3 barrels.

Table A-28 shows the estimated crude oil-spill rate for the Alaska North Slope is 188 spills per billion barrels produced. Table A-29 shows the assumed number, size, and

total volume of small spills for the Liberty Project. Table A-30 shows the assumed size distribution of those spills.

The causes of Alaska North Slope crude oil spills, in decreasing order of occurrence by frequency, are leaks, faulty valve/gauges, vent discharges, faulty connections, ruptured lines, seal failures, human error, and explosions. The cause of approximately 30% of the spills is unknown.

2. Results for Small Operational Refined Oil Spills

The typical refined products spilled are aviation fuel, diesel fuel, engine lube, fuel oil, gasoline, grease, hydraulic oil, transformer oil, and transmission oil. Diesel spills are 60% of refined oil spills by frequency and 83% by volume. Engine lube oil spills are 9% by frequency and 3% by volume. Hydraulic oil is 23% by frequency and 10% by volume. All other categories are less than 1% by frequency and volume. Refined oil spills occur in conjunction with oil exploration and production. The refined oil spills correlate to the volume of Alaska North Slope crude oil produced. As production of crude oil has declined, so has the number of refined oil spills. Table A-31 shows that from January 1989-December 1998, the spill rate for refined oil is 445 spills per billion barrels produced. Table A-32 shows the assumed refined oil spills during the lifetime of the Liberty Project.

C. CUMULATIVE ANALYSIS

In this section, we discuss how we estimate the oil spills we analyze in the cumulative analysis (Sec. V).

The TAPS pipeline, onshore Alaska North Slope, TAPS tankers, and the Alaska outer continental shelf have varying spill rates and spill-size categories. Table A-33 summarizes these spill rates and spill-size categories we assume for purposes of analysis. We use these spill rates and size categories to estimate oil spills for the cumulative case. All oil originating from either onshore or offshore on the North Slope of Alaska flows through the TAPS pipeline and into TAPS tankers.

The resources and reserves we use to estimate oil spills in the cumulative case are shown in Table A-34. For purposes of quantitative analysis of oil spills, we focus on the past, present, and reasonably foreseeable production. Past, present, and reasonably foreseeable production contributes 10.04 billion barrels in reserves and resources, with Liberty contributing 0.12 billion barrels for a total of 10.16 billion barrels.

Table A-35 shows the number and volume of spills we estimate for the cumulative case. It is unlikely that Liberty would contribute an oil spill offshore in the Beaufort Sea or

along the TAPS tanker route. For purposes of analysis in the cumulative case, we assume Liberty would not contribute an oil spill offshore in the Beaufort Sea or along the TAPS tanker route.

The pipeline and platform spill size in the Beaufort Sea ranges from 125-2,956 barrels. The onshore spill size ranges from 500-925 barrels. For purposes of analysis, we assume a TAPS pipeline spill ranging from 500-1,000 barrels (Table A-36). We discuss the average size of a spill from a TAPS tanker in the following subsections.

Table A-35 shows we estimate one spill from projects in the Beaufort Sea greater than or equal to 500 barrels over the lifetime of the Liberty Project. For purposes of analysis, we assume this spill could range from 125-2,956 barrels. The primary source of this spill is from a facility. Based on the pollution-prevention methods, regulatory mandates for tanks, and design features of the island, it is unlikely a spill would leave the gravel island.

We base these spill estimates on production from past, present, and reasonably foreseeable development. Possible offshore sources in these categories include Endicott, Northstar, Kalubik, Gwydyr Bay, Flaxman Island, Kuvlum, and Hammerhead. This category also includes potential production from undiscovered resources on Federal leased tracts in the Beaufort Sea.

Table A-35 shows we assume one spill greater than or equal to 500 barrels from the TAPS pipeline from other projects. It is unlikely that Liberty would contribute an oil spill along the TAPS pipeline.

Table A-35 shows we also estimate 9 spills greater than or equal to 1,000 barrels from other projects along the TAPS tanker route. Table A-36 shows the actual tanker spills along the TAPS tanker route to date. We use information from Table A-36 to estimate the size and location of the 9 spills we assume. By location, we mean if the spill occurs in port or at sea.

Table A-37 shows our estimates of the size of those 9 spills. We estimate six spills—four in port and two at sea—with an average size of 4,000 barrels; two spills at sea with an average size of 14,000 barrels; and one spill at sea with a size ranging from 200,000-260,000 barrels. For purposes of analysis, we use 250,000 barrels. Previous studies show that the chance of one or more spills occurring and contacting land along the U.S. coast adjacent to the TAPS tanker route is less than or equal to 3% (LaBelle et al., 1996).

For More Information: The report *Oil-Spill-Risk Analysis: Liberty Development and Production Plan* (Johnson, Marshall and Lear, 2000.) describes how we analyze oil spills in terms of their risk to the environment. This includes how the oil spill is followed through time, and how often the oil contacts areas of concern.

For a copy of this report:

- call 1-800-764-2627
- request by email through akwebmaster@mms.gov
- download a copy from the MMS, Alaska OCS Region homepage at <http://www.mms.gov/alaska/cproject/liberty/INDEX.HTM>
- write or visit the Minerals Management Service at 949 East 36th Avenue Anchorage, AK 99508-4363.

REFERENCE LIST

- Anderson, C.M. 2000a. Email dated Jul. 26, 2000, from cheryl.anderson@mms.gov to caryn.smith@mms.gov; subject: revised rates.
- Anderson, C.M. 2000b. Email dated Feb. 24, 2000, from cheryl.anderson@mms.gov to Caryn Smith and Dick Prentki, USDO, MMS, Alaska OCS Region; subject: possible crude oil spill rates for North Slope oil production; assistance with spill rates.
- Anderson, C.M. and R.P. LaBelle. 1994. Comparative Occurrence Rates for Offshore Oil Spills. *Spill Science and Technology Bulletin* 12:131-141.
- Anderson, C.M. and E.M. Lear. 1994. Tanker Spill Data Base. MMS Report, OCS 94-0002. Herndon, VA: USDO, MMS.
- Armstrong, R.L. and M.J. Brodzik. 1995. An Earth-Gridded SSM/I Data Set for Cryospheric Studies and Global Change Monitoring. *Advanced Space Research* 16:155-163.
- Boehm, P.D. 1987. Transport and Transformation Processes Regarding Hydrocarbon and Metal Pollutants in Offshore Sedimentary Environments. *In: Long-Term Environmental Effects of Offshore Oil and Gas Development*, D.F. Boesch and N.N. Rabalais, eds. London: Elsevier Applied Science, pp. 233-286.
- BP Exploration (Alaska), Inc. 1999. Oil Discharge Prevention and Contingency Plan. Liberty Development Area, North Slope, Alaska. 4/99, Rev. 0. Anchorage, AK: BPXA.
- BP Exploration (Alaska), Inc. 2000. Oil Discharge Prevention and Contingency Plan. Liberty Development Area, North Slope, Alaska. 6/00, Rev. 0. Anchorage, AK: BPXA.
- Chedin, A., N.A. Scott, C. Wahiche, and P. Moulineir. 1985. The Improved Initialization Inversion Method: A High Resolution Physical Method for Temperature Retrievals from Satellites of the TIROS-N Series. *Journal of Climate and Applied Meteorology* 24:128-143.
- D.F. Dickins Associates Ltd. 1992. Behavior of Spilled Oil at Sea (BOSS): Oil-in-Ice Fate and Behavior. Ottawa, Ontario, Canada: Environment Canada, pp. 1-1 to 9-10.
- Daling, P.S. and T. Strom. 1999. Weathering of Oils at Sea: Model/Field Data Comparisons. *Spill Science and Technology* 51:63-74.
- Fairweather. 2000. Historical Blowout Study North Slope, Alaska. Anchorage, AK: BPXA.
- Fingas, M.F. 1996. The Evaporation of Oil Spills: Variation with Temperature and Correlation with Distillation Data. *In: Proceedings of the Nineteenth Arctic and Marine Oilspill Program (AMOP) Technical Seminar*, Calgary, Canada. Ottawa, Ontario, Canada: Environment Canada, pp. 29-72.
- Francis, J.A. 1994. Improvements to TOVS Retrievals Over Sea Ice and Applications to Estimating Arctic Energy Fluxes. *Journal of Geophysical Research* 99D5:10,395-10,408.
- Francis, J.A. 1999. The NASA/NOAA TOVS Polar Pathfinder – 18 Years of Arctic Data. The Fifth Conference on Polar Meteorology and Oceanography. Dallas, TX: American Meteorological Society.
- Free, A.P., J.C. Cox; and L.A. Schultz. 1982. Laboratory Studies of Oil Spill Behavior in Broken Ice Fields. *In: Proceedings of the Fifth Arctic Marine Oil Spill Program Technical Seminar*, Edmonton, Alberta, Canada. Ottawa, Ontario, Canada: Environment Canada, pp. 3-14.
- Galt, J.A. 1980. A Finite Element Solution Procedure for the Interpolation of Current Data in Complex Regions. *Journal of Physical Oceanography* 10(12):1984-1997.
- Galt, J.A. and D.L. Payton. 1981. Finite-Element Routines for the Analysis and Simulation of Nearshore Currents. *In: Comptes Rendus du Colloque, Mechanics of Oil Slicks*, Paris, France. Paris: International Association for Hydraulic Research, pp. 121-122.
- Haidvogel, D.B., J.L. Wilkins, and R. Young. 1991. A Semi-Spectral Primitive Equation Ocean Circulation Model Using Vertical Sigma and Orthogonal Curvilinear Horizontal Coordinates. *Journal of Computational Physics* 94:151-185.
- Hart Crowser, Inc. 2000. Estimation of Oil Spill Risk from Alaska North Slope, Trans-Alaska Pipeline and Arctic Canada Oil Spill Data Sets. OCS Study, MMS 2000-007. Anchorage, AK: USDO, MMS, Alaska OCS Region, Environmental Studies.
- Hedstrom, K.S. 1994. Technical Manual for a Coupled Sea-Ice/Ocean Circulation Model (Version 1). Technical Report. OCS Study, MMS 94-0001. Anchorage, AK: USDO, MMS, Alaska OCS Region, Environmental Studies, 53 pp.
- Hedstrom, K.S., D.B. Haidvogel, and S. Signorini. 1995. Model Simulations of Ocean/Sea-Ice Interaction in the Western Arctic in 1983. OCS Study, MMS 95-0001. Anchorage, AK: USDO, MMS, Alaska OCS Region, Environmental Studies, 78 pp.
- Hibler, W.D., III. 1979. A Dynamic Thermodynamic Sea Ice Model. *Journal of Physical Oceanography* 9:815-846.
- Hollebone, B.P. 1997. The Fate and Behavior of Oil in Freezing Environments (draft). Ottawa, Ontario, Canada: Environment Canada, 470 pp.
- Huang, J.C. and F.M. Monastero. 1982. Review of the State-of-the-Art of Oilspill Simulation Models. Washington, DC: American Petroleum Institute.

- INTEC. 2000. Pipeline System Alternatives, Liberty Development Project Conceptual Engineering. INTEC Project No. H-0851.02. Project Study PS 19. Anchorage, AK: INTEC, 269 pp. plus appendices.
- Johnson, W., C. Marshall, and E. Lear. 2000. Oil Spill Risk Analysis. Liberty Development and Production Plan. OCS Report, MMS 2000-0059. Herndon, VA: USDO, MMS.
- LaBelle, R.P., C.M. Marshall, C. Anderson, W. Johnson, and E. Lear. 1996. Oil Spill Risk Analysis for Alaska North Slope Oil Exports (Domestic Movement). Herndon, VA: USDO, MMS, Branch of Environmental Operations and Analysis, 9 pp. plus tables.
- Mallory, C.R. 1998. A Review of Alaska North Slope Blowouts, 1974-1997. Document II-9 in Preliminary Analysis of Oil Spill Response Capability in Broken Ice to Support Request for Additional Information for Northstar Oil Spill Contingency Plan, Vol. II. Anchorage, AK: BPXA and ARCO Alaska.
- Payne, J.R., G.D. McNabb, and J.R. Clayton. 1991. Oil Weathering Behavior in Arctic Environments. *In*: Proceedings from the Pro Mare Symposium on Polar Marine Ecology, Trondheim, Norway, pp. 631-662.
- Payne, J.R., G.D. McNabb, L.E. Hachmeister, B.E. Kirstein, J.R. Clayton, C.R. Phillips, R.T. Redding, C.L. Clary, G.S. Smith, and G.H. Farmer. 1987. Development of a Predicting Model for Weathering of Oil in the Presence of Sea Ice. OCS Study, MMS 89-0003. OCSEAP Final Reports of Principal Investigators Vol. 59 (Nov. 1988). Anchorage, AK: USDOC, NOAA, OCSEAP, and USDO, MMS, Alaska OCS Region, pp. 147-465.
- Reed, M., N. Ekrol, P. Daling, O. Johansen, M.K. Ditlevsen, and I. Swahn. 2000. SINTEF Oil Weathering Model User's Manual, Version 1.8. Trondheim, Norway: SINTEF Applied Chemistry, 38 pp.
- S.L. Ross Environmental Research Ltd.. 1998. Laboratory Testing to Determine Spill Related Properties of Liberty Crude Oil. Anchorage, AK: BPXA.
- S.L. Ross Environmental Research Ltd. 2000. Preliminary Evaluation of Behavior and Cleanup of Liberty Crude Oil Spills in Arctic Waters. Anchorage, AK: BPXA, 32 pp.
- Samuels, W.B., N.E. Huang, and D.E. Amstutz. 1982. An Oilspill Trajectory Analysis Model with a Variable Wind Deflection Angle. *Ocean Engineering* 94:347-360.
- Smith, R.A., J.R. Slack, T. Wyant, and K.J. Lanfear. 1982. The Oilspill Risk Analysis Model of the U.S. Geological Survey. Geological Survey Professional Paper 1227. Washington, DC: U.S. Government Printing Office, 40 pp.
- Stolzenbach, K.D., S. Madsen, E.E. Adams, A.M. Pollack, and C.K. Cooper. 1977. A Review and Evaluation of Basic Techniques for Predicting the Behavior of Surface Oil Slicks. Report No. MITSG 77-8. Cambridge, MA: MIT Sea Grant Program, Ralph M. Parsons Laboratory, 322 pp.
- Volt, G. 1997. Telephone conversation in April 1997 from C. Smith, USDO, MMS, Alaska OCS Region, to G. Volt, State of Alaska, Department of Environmental Conservation, Spill Prevention and Response, Anchorage Office; subject: ADEC oil-spill database quality assurance/quality control.

Table A-1 Large, Small, and Very Large Spill Sizes We Assume for Analysis in this EIS by Section

EIS Section	Source of Spill	Type of Oil	Size of Spill(s) in Barrels	Receiving Environment
Large Spills (≥ 500 barrels)				
III.C.2 IV.C	Offshore Pipeline	Crude	715, 1,580, 2,956	Open Water Under Ice
	Gravel Island	Crude	925	On Top of Sea Ice Broken Ice
	Storage Tank	Diesel	1,283	Snow Ice River Tundra
	Onshore Pipeline	Crude	720 ¹ – 1,142 ²	
Small Spills (< 500 barrels)				
III.D.3	Offshore Pipeline	Crude	125	Under Sea Ice Open Water On Top of Sea Ice Broken Sea Ice
	Offshore and Onshore Operational Spills from All Sources	Diesel or Crude	17 spills < 1 barrel 6 spills ≥ 1 barrel but < 25 barrels	Gravel Island Open Water On Top of Sea Ice Broken Sea Ice Snow/Ice Tundra
	Onshore and Offshore	Refined	53 spills of 0.7 barrels each	
Very Large Spills (≥ 150,000 barrels)				
IX	Blowout from the Gravel Island	Crude	180,000	Open Water On Top of Sea Ice Broken Sea Ice
	Tanker Spill in the Gulf of Alaska	Crude	200,000	Open Water

Source: USDOl, MMS Alaska OCS Region (2000).

¹ This volume was calculated in BPXA (1999:2-23). This calculation assumes the leak is less than or equal to 1% of the flow (barrel), 97.5 barrels is released for 7 days before detection. The potential volume released during reaction is 2.3 barrels. The expansion volume is 29 barrels, and maximum drainage due to gravity is negligible.

² This volume was calculated in BPXA (2000:2-18) and represents a guillotine cut. It assumes 14 minutes for detection confirmation and complete shutdown.

Table A-2 Large and Small Spill Sizes We Assume for Analysis in this EIS by Alternative

	ASSUMED SPILL SIZE IN BARRELS									
	LARGE						SMALL			
	CRUDE OIL						DIESEL OIL	CRUDE OR DIESEL		REFINED OIL
	GRAVEL ISLAND ¹	OFFSHORE PIPELINE					ONSHORE PIPELINE	GRAVEL ISLAND (Diesel Tank)	OPERATION SPILLS OFFSHORE AND ONSHORE	OPERATION SPILLS OFFSHORE AND ONSHORE
		Leak Detection and Location System		Pressure-Point Analysis And Mass-Balance Line Pack-Compensation						
Leak		Rupture	Summer Leak	Winter Leak	Rupture					
Alternative I BPXA Proposal	925	125	1,580	715	2,956	1,580	720-1,142	1,283	17<1 bbl, 6 ≥ 1 and < 25 bbl	53 of 0.7 bbl
Alternative II, No Action	Spills occur elsewhere from oil reserves produced at another location									
Alternative III, Use Alternative Island Locations and Pipeline Routes	925	125	1,580	715	2,956	1,580	720-1,142	1,283	17<1 bbl, 6 ≥ 1 and < 25 bbl	53 of 0.7 bbl
Alternative IV, Use Different Pipeline Designs										
Assumption 1, Neither Outer nor Inner Pipe Leaks										
Alternative IVA Use Pipe in Pipe System	925	0			0		720-1,142	1,283	17<1 bbl, 6 ≥ 1 and < 25 bbl	53 of 0.7 bbl
Alternative IVB Use Pipe in HDPE System	925	0			0		720-1,142	1,283	17<1 bbl, 6 ≥ 1 and < 25 bbl	53 of 0.7 bbl
Alternative IVC Use Flexible Pipe System	925	0			0		720-1,142	1,283	17<1 bbl, 6 ≥ 1 and < 25 bbl	53 of 0.7 bbl
<i>Alternative I Single Wall (for comparison)</i>	925	0			0		720-1,142	1,283	17<1 bbl, 6 ≥ 1 and < 25 bbl	53 of 0.7 bbl
Assumption 2, Both Outer and Inner Pipes Leak										
Alternative IVA Use Steel Pipe in Pipe System	925	125	1,580	715	2,956	1,580	720-1,142	1,283	17<1 bbl, 6 ≥ 1 and < 25 bbl	53 of 0.7 bbl
Alternative IVB Use Pipe in HDPE System	925	125	1,580	715	2,956	1,580	720-1,142	1,283	17<1 bbl, 6 ≥ 1 and < 25 bbl	53 of 0.7 bbl
Alternative IVC Use Flexible Pipe System	925	125	1,580	715	2,956	1,580	720-1,142	1,283	17<1 bbl, 6 ≥ 1 and < 25 bbl	53 of 0.7 bbl
<i>Alternative I Single Wall (for comparison)</i>	925	125	1,580	715	2,956	1,580	720-1,142	1,283	17<1 bbl, 6 ≥ 1 and < 25 bbl	53 of 0.7 bbl
Assumption 3, Only the Inner Pipe Leaks										
Alternative IVA Use Pipe in Pipe System	925	0			0		720-1,142	1,283	17<1 bbl, 6 ≥ 1 and < 25 bbl	53 of 0.7 bbl
Alternative IVB Use Pipe in HDPE System	925	0			0		720-1,142	1,283	17<1 bbl, 6 ≥ 1 and < 25 bbl	53 of 0.7 bbl
Alternative IVC Use Flexible Pipe System	925	125	1,580	715	2,956	1,580	720-1,142	1,283	17<1 bbl, 6 ≥ 1 and < 25 bbl	53 of 0.7 bbl
<i>Alternative I Single Wall (for comparison)</i>	925	125	1,580	715	2,956	1,580	720-1,142	1,283	17<1 bbl, 6 ≥ 1 and < 25 bbl	53 of 0.7 bbl
Assumption 4, Only the Outer Pipe Leaks										
Alternative IVA Use Pipe in Pipe System	925	0			0		720-1,142	1,283	17<1 bbl, 6 ≥ 1 and < 25 bbl	53 of 0.7 bbl
Alternative IVB Use Pipe in HDPE System	925	0			0		720-1,142	1,283	17<1 bbl, 6 ≥ 1 and < 25 bbl	53 of 0.7 bbl
Alternative IVC Use Flexible Pipe System	925	Na	Na	Na	Na	Na	720-1,142	1,283	17<1 bbl, 6 ≥ 1 and < 25 bbl	53 of 0.7 bbl
<i>Alternative I Single Wall (for comparison)</i>	925	Na	Na	Na	Na	Na	720-1,142	1,283	17<1 bbl, 6 ≥ 1 and < 25 bbl	53 of 0.7 bbl
Alternative V, Use Steel Sheetpile	925	125	1,580	715	2,956	1,580	720-1,142	1,283	17<1 bbl, 6 ≥ 1 and < 25 bbl	53 of 0.7 bbl
Alternative VI, Use Duck Island Mine	925	125	1,580	715	2,956	1,580	720-1,142	1,283	17<1 bbl, 6 ≥ 1 and < 25 bbl	53 of 0.7 bbl
Alternative VII, Use a 15-Foot Trench Depth	925	125	1,580	715	2,956	1,580	720-1,142	1,283	17<1 bbl, 6 ≥ 1 and < 25 bbl	53 of 0.7 bbl

Source: USDOJ, MMS Alaska OCS Region.

¹ The revised Oil Discharge Prevention and Contingency Plan prohibits the drilling of new wells or sidetracks from existing wells into major liquid hydrocarbon zones at its drill sites during the defined period of broken ice and open water (BPXA, 2001; Section 2.1.7). This period begins on June 13 of each year and ends with the presence of 18 inches of continuous ice cover for one-half mile, in all directions, from the Liberty island. The purpose of this drilling moratorium is to eliminate the environmental effects associated with a well blowout during drilling operations in the Beaufort Sea during broken-ice or open-water conditions.

Table A-3 Comparison of Estimated Sizes of Spills to Median Sizes of Spills

Source of Spill	Type of Oil	Estimated Size of Spill in Barrels		Median Size of Spill in Barrels				
		BPXA	MMS	U.S. OCS	Alaska North Slope	CONCAWE	U.S.DOT	Trans-Alaska Pipeline
		Estimate of Greatest Possible Discharge	Estimate of Possible Discharge Without Drainage					
Offshore								
Pipeline								
Open Water	Crude Oil	1,764	125, 715 , 1580	5,100	510	1,950	2,400	3,200
Under Ice	Crude Oil	1,764	125, 1,580, 2,956	5,100	510	1,950	2,400	3,200
Gravel Island	Crude Oil	178,800		7,000	663 ³			
Tank	Diesel Fuel	5,000	1,283	7,000				
Onshore								
Pipeline	Crude Oil	720 – 1, 142			510	1,950	2,400	3,200

Source: USDOJ, MMS, Alaska OCS Region (2000) and BPXA (2000).

¹ Estimate prepared for State of Alaska Response Planning Standards, 18 AAC 75.340.

² Anderson and LaBelle (2001)

³ Gravel island is assumed equivalent to an onshore gravel pad.

Table A-4 Properties of Liberty Crude Oil

Property		Weathering (volume %)				
in English Units	in Metric Units	0	11.5	20.0		
Density (g/cm ³) 34°F 60°F 85°F	Density (g/m L) 1°C 15°C 30°C	0.922 0.911 0.899	0.940 0.929 0.918	NA* 0.936 0.926		
Viscosity Dynamic (cP) 60°F 85°F Kinematic (cST) 60°F 85°F	Viscosity Dynamic (mPa.s) 15°C 30°C Kinematic (mm ^{2/s}) 15°C 30°C	143 33 156 37	746 92 801 100	2715 178 2901 192		
Interfacial Tensions @ 72°F (dynes/cm) Air/Oil Oil/Seawater	Interfacial Tensions @ 22°C (mNm) Air/Oil Oil/Seawater	32.7 23.7	30.8 23.5	35.7 27.2		
Pour Point °F	Pour Point °C	37 3	54 3	64 18		
Flash Point °F	Flash Point °C	52 11	174 79	266 130		
Emulsion Formation @ 72°F Tendency Stability	Emulsion Formation @ 22°C Tendency Stability	1 1	1 1	1 1		
ASTM Modified Distillation (°C)						
		Evaporation (% volume)	Liquid Temperature		Vapor Temperature	
			°F	°C	°F	°C
		1B.P	256	125	147	64
		5	424	218	270	132
		10	494	257	360	182
		15	560	294	447	231
		20	613	323	516	269
		25	654	346	570	299
		30	699	370	600	316
		35	737	392	643	340

Source: S.L. Ross Environmental Research Ltd. (1998).

Tables A-5 Summary of the Predicted Short-Term Behavior of a 1,000-Barrel Batch Slick of Liberty Crude Oil in Spring Breakup, Winter Ice, Fall Freezeup, and Summer Open-Water Conditions**a. Average Environmental Conditions Assumed to Each Scenario**

	Summer	Fall Freeze-Up	Winter	Spring Break-Up
Wind Speed (knots)	10	10	10	10
Ice Cover	open water	3-7 tenths ice cover	100% ice cover (fast ice)	3-7 tenths ice
Air Temperature (°F)	45	15	-15	40
Surface Temperature (°F)				
Sea	37	32		32
Ice			-15	

Source: S.L. Ross Environmental Research Ltd. (2000).

b. Predicted Characteristics of a 1,000-Barrel Batch Slick of Liberty Crude

Scenario and Elapsed Time	Evaporated (%)	Naturally Dispersed (%)	Remaining (%)
In Spring, Breakup Conditions			
1 Day	6	0.012	93.98
3 Days	9	0.024	90.91
On Winter Ice			
1 Day	0.9	0	99.1
3 Days	2.1	0	97.9
In Fall, Freezeup Conditions			
1 Day	3	0.01	96.99
3 Days	6	0.024	93.09
In Summer, Open-Water Conditions			
1 Day	7	0.015	92.98
3 Days	9	0.028	91.07

Source: S.L. Ross Environmental Research Ltd. (2000).

Table A-6 SINTEF Results of Weathering**a. 125 Barrels of Liberty Crude Oil**

During Open Water				During Melt Out Into 50 Percent Ice			
Hours	Evaporated	Dispersed	Remaining	Hours	Evaporated	Dispersed	Remaining
6	8	1.1	90.9	6	5	0	95
12	9	1.7	89.3	12	6	0	94
24	11	2.6	86.4	24	8	0	92
48	12	4.1	83.9	48	9	0.1	90.9
72	13	5.5	81.5	72	10	0.1	89.9
240	15	13	72	240	13	0.5	86.5
480	16	20.9	63.1	480	15	1	84
720	17	27.1	55.9	720	16	1.4	82.6

b. 715 Barrels of Liberty Crude Oil

During Open Water				During Melt Out Into 50 Percent Ice			
Hours	Evaporated	Dispersed	Remaining	Hours	Evaporated	Dispersed	Remaining
6	9	1.1	89.9	6	4	0	96
12	10	1.7	88.3	12	5	0	95
24	11	2.6	86.4	24	6	0	94
48	12	4.1	83.9	48	8	0	92
72	13	5.5	81.5	72	9	0.1	90.9
240	15	13	72	240	12	0.2	87.8
480	16	20.9	63.1	480	13	0.4	86.6
720	17	27.1	55.9	720	15	0.7	84.3

c. 925 Barrels of Liberty Crude Oil

During Open Water				During Melt Out Into 50 Percent Ice			
Hours	Evaporated	Dispersed	Remaining	Hours	Evaporated	Dispersed	Remaining
6	4	0.1	95.5	6	4	0	95.6
12	6	0.2	94.2	12	6	0	94.4
24	7	0.3	92.6	24	7	0	92.9
48	9	0.7	90.5	48	8	0	92
72	10	1.0	89.3	72	9	0.1	90.9
240	13	3.8	83.6	240	12	0.2	87.8
480	14	8.0	77.6	480	13	0.4	86.6
720	15	12.2	72.8	720	14	0.6	85.4

d. 1,580 Barrels of Liberty Crude Oil

During Open Water				During Melt Out Into 50 Percent Ice			
Hours	Evaporated	Dispersed	Remaining	Hours	Evaporated	Dispersed	Remaining
6	4	0.1	95.9	6	4	0	96
12	5	0.2	94.8	12	5	0	95
24	7	0.3	92.7	24	6	0	94
48	8	0.5	91.5	48	7	0	93
72	9	0.8	90.2	72	8	0	92
240	12	3.0	87.7	240	11	0.2	88.8
480	14	6.3	79.7	480	13	0.3	86.7
720	15	9.7	75.3	720	14	0.5	85.5

e. 2,956 Barrels of Liberty Crude Oil

				During Melt Out Into 50 Percent Ice			
				Hours	Evaporated	Dispersed	Remaining
We do not assume a 2,956 barrel crude oil spill will occur during open water.				6	4	0	96
				12	4	0	96
				24	5	0	95
				48	7	0	93
				72	8	0	92
				240	11	0.1	88.9
				480	12	0.2	87.8
				720	13	0.4	86.6

f. 1,283 Barrels of Diesel Oil

During Open Water				During Melt Out Into 50 Percent Ice			
Hours	Evaporated	Dispersed	Remaining	Hours	Evaporated	Dispersed	Remaining
6	5	11.7	83.3	6	3	0.4	96.6
12	7	21.8	71.2	12	5	0.8	94.2
24	11	37.8	51.2	24	8	1.5	90.5
48	16	57.8	26.2	48	12	3.0	87.7
72	18	68	14	72	16	4.5	79.5
120	20	76.3	3.7	240	28	13.7	58.3
144	20	77.9	2.1	480	34	24.4	41.6
				720	38	32.6	29.4

Source: Reed et al. (2000)

Table A-7 Assumed Fate and Behavior of a Spill of Liberty Crude Oil Ranging in Size from 715-2,956 Barrels

Time After Spill in Days	Summer Spill ¹ (715-1580)				Broken Ice or Meltout Spill ² (715-2,956)				Winter Under Ice Spill ³ (2,956)			
	1	3	10	30	1	3	10	30	1	3	10	30
Oil Remaining (%)	86-93	82-91	72-88	56-75	93-94	91-92	88-89	84-87	100	100	100	100
Oil Dispersed (%)	0.15-2.6	0.28-5.5	3 -13	10 - 27	0-0.012	0-0.024	0.1-0.2	0.4-0.7	0	0	0	0
Oil Evaporated (%)	7-11	9-13	12-15	15 - 17	6-7	8-9	11-12	13-15	0	0	0	0
Discontinuous Area (km ²) ⁴	1-2	6-9	30-45	124-186	1-2	3-7	17-36	73-150	3/4 to 3 acres			
Estimated Coastline Oiled (km) ⁵	21-30				23-45				0			

Source: USDO, MMS, Alaska OCS Region (2000). Information from S.L. Ross Oil Spill Model calculated with Liberty Crude Oil (BPXA, 2000) and the SINTEF oil-weathering assuming a Liberty crude (Reed et al., 2000). For footnotes, see below.

Table A-8 Assumed Fate and Behavior of a 125-Barrel Crude Oil Spill over 24 Hours

Time After Spill in Days	Summer Spill ¹				Winter Broken Ice or Meltout Spill ²			
	1	3	10	30	1	3	10	30
Oil Remaining (%)	86	82	72	56	92	90	87	83
Oil Dispersed (%)	2.6	5.5	13	27.1	0	0.1	0.5	1.4
Oil Evaporated (%)	11	13	15	17	8	10	13	16
Discontinuous Area (km ²) ⁴	0.5	3	12	51	0.4	1	7	30
Estimated Coastline Oiled (km) ⁵	9							

Source: USDO, MMS, Alaska OCS Region (2000). Information the SINTEF oil-weathering model assuming a Liberty crude (Reed et al., 2000). For footnotes, see below.

Table A-9 Assumed Fate and Behavior of a 1,283-Barrel Diesel-Oil Spill

Time After Spill in Days	Summer Spill ¹			Winter Broken Ice or Meltout Spill ²			
	1	3	7	1	3	10	30
Oil Remaining (%)	51	14	2	90	79	58	29
Oil Dispersed (%)	38	68	78	2	5	14	33
Oil Evaporated (%)	11	18	20	8	16	28	38
Discontinuous Area (km ²) ⁴	1	7	18	1	5	25	103

Source: USDO, MMS, Alaska OCS Region (2000). Calculated with the Reed et al. (2000) weathering model, assuming a Marine Diesel.

Footnotes:

¹Summer (July through September) open water spill, 12-kn wind speed, 2° C, 0.4-m wave height.

²Winter (October through June) meltout spill. The spill is assumed to occur during the winter under the landfast ice, pools 2-cm thick on ice surface for 2 days at 0 °C prior to meltout into 50-percent ice cover, 11-kn wind speed, and 0.1 wave height.

³Qualitative estimate of fate and behavior of under-ice spill taken from D.F. Dickens Associates Ltd. (1992) and Hollebne (1997).

⁴Calculated from Equation 6 of Table 2 in Ford (1985) and is the discontinuous area of a continuing spill or the area swept by an instantaneous spill of a given volume.

⁵Calculated from Equation 17 of Table 4 in Ford (1985) and is the results of stepwise multiple regression for length of historical coastline oiled.

Table A-10 Environmental Resource Areas: Name, Vulnerable Period, and Identification Number on Maps A-1 and A-2

ID	Name	Vulnerable	ID	Name	Vulnerable
1	Spring Lead 1	April-May	32	Water surface over Boulder Patch 1	January-December
2	Spring Lead 2	April-May	33	Water surface over Boulder Patch 2	January-December
3	Spring Lead 3	April-May	34	ERA 34	May-October
4	Spring Lead 4	April-May	35	ERA 35	May-October
5	Spring Lead 5	April-May	36	ERA36	May-October
6	Ice/Sea Segment 6	January-December	37	ERA 37	May-October
7	Ice/Sea Segment 7	January-December	38	ERA 38	May-October
8	Ice/Sea Segment 8	January-December	39	ERA 39	May-October
9	Ice/Sea Segment 9	January-December	40	ERA 40	May-October
10	Ice/Sea Segment 10	January-December	41	ERA 41	May-October
11	Ice/Sea Segment 11	January-December	42	Canning River	May-October
12	Ice/Sea Segment 12	January-December	43	ERA 43	May-October
13	Ice/Sea Segment 13	January-December	44	Simpson Cove	May-October
14	ERA 14	May-October	45	ERA 45	May-October
15	ERA 15	May-October	46	Arey Lagoon, Hula Hula River	May-October
16	ERA 16	May-October	47	Whaling Area/Kaktovik	August-October
17	ERA 17	May-October	48	Thetis Island	January-December
18	ERA 18	May-October	49	Spy Island	January-December
19	ERA 19	May-October	50	Leavitt and Pingok Islands	January-December
20	ERA 20	May-October	51	Bertoncini, Bodfish, and Cottle Islands	January-December
21	ERA 21	May-October	52	Long Island	January-December
22	Simpson Lagoon	May-October	53	Egg and Stump Islands	January-December
23	Gwydyr Bay	May-October	54	West Dock	January-December
24	ERA 24	May-October	55	Reindeer and Argo Islands	January-December
25	Prudhoe Bay	May-October	56	Cross and No Name Islands	January-December
26	ERA 26	May-October	57	Endicott Causeway	January-December
27	ERA 27	May-October	58	Narwhal, Jeanette and Karluk Island	January-December
28	ERA 28	May-October	59	Tigvariak Island	January-December
29	ERA 29	May-October	60	Pole and Belvedere Islands	January-December
30	ERA 30	May-October	61	Challenge, Alaska, Duchess, and Northstar Islands	January-December
31	ERA 31	January-December	62	Flaxman Island	January-December

Source: USDO, MMS, Alaska OCS Region (2000).

Table A-11 Locations Where We Simulate Oil Spills From for Each Alternative – Map A-6

Alternative	Gravel Island	Pipelines
I Use the Liberty Island and Pipeline Route	L1	PP1 and PP2
II No Action	None	None
III.A Use the Southern Island and the Eastern Pipeline Route	AP1	AP1 and AP2
III.B Use the Tern Island Location and Tern Pipeline Route	T1	TP1 and TP2
IV.A Use Pipe-in-Pipe System	L1, AP1 or T1	PP1,PP2 or AP1,AP2 or TP1,TP2
IV.B Use Pipe-in-HDPE System	L1, AP1 or T1	PP1,PP2 or AP1,AP2 or TP1,TP2
IV.C Use Flexible Pipe System	L1, AP1 or T1	PP1,PP2 or AP1,AP2 or TP1,TP2
V Use Steel Sheetpile to Protect the Upper Slope of the Island	L1, AP1 or T1	PP1,PP2 or AP1,AP2 or TP1,TP2
VI Use Duck Island Gravel Mine	L1, AP1 or T1	PP1,PP2 or AP1,AP2 or TP1,TP2
VII Use a 15-Foot Pipeline Burial Depth	L1, AP1 or T1	PP1,PP2 or AP1,AP2 or TP1,TP2

Source: USDOl, MMS, Alaska OCS Region (2000)

Table A-12 Conditional Probabilities (Expressed as Percent Chance) That an Oil Spill Starting at L1 in Summer or Winter Will Contact a Certain Environmental Resource Area (ERA) Within 1, 3, 10, 30, 60, Or 360 Days, Liberty Island

ERA	L1 Winter (Days)						L1 Summer (Days)					
	1	3	10	30	60	360	1	3	10	30	60	360
Land All Land Segments	1	4	8	13	23	98	27	54	74	87	93	94
1 Spring Lead 1	n	n	n	n	n	n	n	n	n	n	n	n
2 Spring Lead 2	n	n	n	n	n	n	n	n	n	n	n	n
3 Spring Lead 3	n	n	n	n	n	n	n	n	n	n	n	n
4 Spring Lead 4	n	n	n	n	n	n	n	n	n	n	n	n
5 Spring Lead 5	n	n	n	n	n	n	n	n	n	n	n	n
6 Ice/Sea Segment 6	n	n	n	n	n	1	n	n	n	n	n	1
7 Ice/Sea Segment 7	n	n	n	n	1	1	n	n	1	3	3	3
8 Ice/Sea Segment 8	n	n	n	1	1	1	n	n	1	1	2	2
9 Ice/Sea Segment 9	n	n	1	1	2	4	n	n	3	3	4	4
10 Ice/Sea Segment 10	n	n	1	2	2	5	n	1	3	4	5	5
11 Ice/Sea Segment 11	n	n	1	1	1	5	n	1	5	8	8	8
12 Ice/Sea Segment 12	n	n	n	n	n	1	n	n	1	3	3	3
13 Ice/Sea Segment 13	n	n	n	n	n	n	n	n	1	3	3	3
14 ERA 14	n	n	n	n	n	n	n	n	n	n	n	n
15 ERA 15	n	n	n	n	n	1	n	n	n	n	n	n
16 ERA 16	n	n	n	n	n	2	n	n	n	n	1	1
17 ERA 17	n	n	n	n	n	4	n	n	1	1	1	1
18 ERA 18	n	n	n	n	n	4	n	n	n	1	2	2
19 ERA 19	n	n	n	n	n	2	n	n	n	2	2	2
20 ERA 20	n	n	n	n	1	4	n	n	2	4	4	4
21 ERA 21	n	n	n	n	1	7	n	n	2	6	7	7
22 Simpson Lagoon	n	n	n	n	1	14	n	2	5	8	10	10
23 Gwydyr Bay	n	n	n	n	1	2	n	2	5	6	6	6
24 ERA 24	n	n	n	1	1	8	n	1	4	7	8	8
25 Prudhoe Bay	n	n	1	1	1	5	1	4	6	6	7	7
26 ERA 26	n	n	1	1	2	8	3	10	12	13	13	14
27 ERA 27	n	1	1	2	3	12	9	15	17	18	18	18
28 ERA 28	n	1	1	3	5	20	2	7	11	11	12	12
29 ERA 29	n	n	1	1	2	11	n	3	7	10	11	11
30 ERA 30	n	1	1	2	3	11	n	6	11	13	14	14
31 ERA 31	n	n	1	1	3	11	n	4	7	9	9	9
32 Water surface over Boulder Patch 1	1	1	3	4	7	25	10	18	21	21	21	21
33 Water surface over Boulder Patch 2	5	6	7	11	17	59	52	59	60	60	61	61
34 ERA 34	1	1	1	2	3	9	10	15	16	17	17	17
35 ERA 35	4	5	6	10	14	46	29	33	34	34	34	34
36 ERA 36	1	2	2	3	5	16	12	14	16	17	17	17
37 ERA 37	1	2	3	4	7	23	6	12	13	14	15	15
38 ERA 38	n	1	2	3	4	15	4	10	12	12	12	13
39 ERA 39	n	1	2	3	4	15	1	6	13	15	16	16
40 ERA 40	n	n	1	2	4	16	n	4	10	13	14	14
41 ERA 41	n	n	1	1	1	7	n	1	6	9	9	9
42 Canning River	n	n	n	n	n	4	n	n	2	3	3	3
43 ERA43	n	n	n	1	1	4	n	n	3	7	7	7
44 Simpson Cove	n	n	n	n	n	2	n	n	1	2	2	2
45 ERA45	n	n	n	n	n	2	n	n	3	5	5	5
46 Arey Lagoon, Hula Hula River	n	n	n	n	n	1	n	n	1	1	2	2
47 Whaling Area/Kaktovik	n	n	n	n	n	1	n	n	1	3	3	3
48 Thetis Island	n	n	n	n	1	5	n	n	1	2	2	2
49 Spy Island	n	n	n	n	1	5	n	n	1	2	3	3
50 Leavitt and Pingok Islands	n	n	n	n	1	8	n	n	3	4	4	4
51 Bertoncini, Bodfish, and Cottle	n	n	n	1	2	15	n	2	6	8	9	10
52 Long Island	n	n	n	1	2	8	n	3	8	9	9	9
53 Egg and Stump Islands	n	n	1	2	3	12	n	6	9	10	10	10
54 West Dock	n	n	1	2	3	11	1	7	9	10	10	10
55 Reindeer and Argo Islands	n	n	1	1	3	10	n	4	7	8	8	8
56 Cross and No Name Islands	n	n	1	1	2	11	n	2	6	7	8	8
57 Endicott Causeway	1	1	2	3	4	15	14	19	21	22	22	22
58 Narwhal, Jeanette and Karluk	1	2	3	4	6	21	6	11	13	15	15	15
59 Tigvariak Island	1	2	2	3	4	13	10	14	16	17	17	17
60 Pole and Belvedere Islands	n	1	2	3	5	16	1	6	8	10	10	10
61 Challenge, Alaska, Duchess a	n	n	1	2	3	13	1	2	5	6	6	7
62 Flaxman Island	n	n	n	1	1	7	n	1	3	4	5	5

Note: n = Less than 0.5%

Table A-13 Conditional Probabilities (Expressed as Percent Chance) That an Oil Spill Starting At L1 in the Summer or Winter Will Contact a Certain Land Segment Within 1, 3, 10, 30, 60, or 360 Days , Liberty Island

Land Segment	L1 Winter (Meltout) (Days)						L1 Summer (Days)					
	1	3	10	30	60	360	1	3	10	30	60	360
16	n	n	n	n	n	3	n	n	n	n	1	1
17	n	n	n	n	n	2	n	n	n	n	n	n
18	n	n	n	n	n	1	n	n	n	n	n	n
19	n	n	n	n	n	1	n	n	n	1	2	2
20	n	n	n	n	n	1	n	n	n	1	1	1
21	n	n	n	n	1	7	n	1	2	3	4	4
22	n	n	n	n	1	4	n	1	4	5	6	6
23	n	n	1	2	3	11	n	4	6	7	7	7
24	n	n	n	n	n	1	n	1	2	3	3	3
25	1	1	1	2	3	7	4	9	12	12	13	13
26	1	2	3	5	8	27	17	22	25	26	26	26
27	n	1	1	2	4	13	5	9	10	11	11	11
28	n	n	1	1	2	7	1	4	6	7	7	7
29	n	n	n	n	1	5	n	1	3	3	4	4
30	n	n	n	n	n	3	n	1	1	2	2	2
31	n	n	n	n	n	1	n	n	n	1	1	1
32	n	n	n	n	n	2	n	n	1	2	2	2
33	n	n	n	n	n	1	n	n	1	2	2	2
34	n	n	n	n	n	n	n	n	n	1	2	2

Note: n = Less than 0.5%, Land Segments 16 through 34 are shown.
All other Land Segments with all values less than 0.5% are not shown.

Table A-14 Conditional Probabilities (Expressed as Percent Chance) That an Oil Spill Starting at T1 in the Summer or Winter Will Contact a Certain Land Segment Within 1, 3, 10, 30, 60, or 360 Days, Tern Island

Land Segment	T1 Winter (Days)						T1 Summer (Days)					
	1	3	10	30	60	360	1	3	10	30	60	360
16	n	n	n	n	n	2	n	n	n	n	1	1
17	n	n	n	n	n	2	n	n	n	n	n	n
18	n	n	n	n	n	1	n	n	n	n	1	1
19	n	n	n	n	n	2	n	n	n	1	1	2
20	n	n	n	n	n	1	n	n	n	1	1	1
21	n	n	n	n	1	7	n	1	2	3	4	4
22	n	n	n	1	1	6	n	1	4	6	6	6
23	n	n	1	2	3	10	n	3	6	6	7	7
24	n	n	n	n	n	1	n	2	3	3	4	4
25	n	1	1	2	2	7	3	9	12	12	13	13
26	1	2	3	4	6	18	14	19	22	22	23	23
27	n	1	1	3	5	19	5	10	11	12	13	13
28	n	1	1	1	2	8	1	5	6	7	7	7
29	n	n	n	n	n	3	n	1	3	4	4	4
30	n	n	n	n	n	4	n	1	1	2	3	3
31	n	n	n	n	n	1	n	n	n	1	1	1
32	n	n	n	n	n	3	n	n	1	2	2	2
33	n	n	n	n	n	3	n	n	1	2	2	3
34	n	n	n	n	n	1	n	n	1	1	2	2

Note: n = Less than 0.5% Land Segments 16 through 34 are shown.
All other Land Segments with all values less than 0.5% are not shown.

Table A-15 Conditional Probabilities (Expressed as Percent Chance) That an Oil Spill Starting at T1 in Summer or Winter Will Contact a Certain Environmental Resource Area (ERA) Within 1, 3, 10, 30, 60, or 360 Days, Tern Island

ERA	TI Winter (Days)						TI Summer (Days)					
	1	3	10	30	60	360	1	3	10	30	60	360
LAND All Land Segments	1	4	8	13	22	98	23	51	73	86	93	94
1 Spring Lead 1	n	n	n	n	n	n	n	n	n	n	n	n
2 Spring Lead 2	n	n	n	n	n	n	n	n	n	n	n	n
3 Spring Lead 3	n	n	n	n	n	n	n	n	n	n	n	n
4 Spring Lead 4	n	n	n	n	n	n	n	n	n	n	n	n
5 Spring Lead 5	n	n	n	n	n	n	n	n	n	n	n	n
6 Ice/Sea Segment 6	n	n	n	n	n	1	n	n	n	n	n	1
7 Ice/Sea Segment 7	n	n	n	n	1	1	n	n	1	3	3	4
8 Ice/Sea Segment 8	n	n	n	1	1	1	n	n	1	1	2	2
9 Ice/Sea Segment 9	n	n	1	1	2	4	n	n	2	3	4	4
10 Ice/Sea Segment 10	n	n	1	2	2	5	n	1	3	5	5	6
11 Ice/Sea Segment 11	n	n	1	1	1	6	n	1	6	8	9	9
12 Ice/Sea Segment 12	n	n	n	n	n	1	n	n	1	3	3	3
13 Ice/Sea Segment 13	n	n	n	n	n	n	n	n	1	3	3	4
14 ERA 14	n	n	n	n	n	n	n	n	n	n	n	n
15 ERA 15	n	n	n	n	n	1	n	n	n	n	n	n
16 ERA 16	n	n	n	n	n	2	n	n	n	n	1	1
17 ERA 17	n	n	n	n	n	4	n	n	1	1	1	1
18 ERA 18	n	n	n	n	1	4	n	n	n	1	2	2
19 ERA 19	n	n	n	n	n	2	n	n	n	2	2	2
20 ERA 20	n	n	n	n	1	5	n	n	1	3	4	4
21 ERA 21	n	n	n	n	1	8	n	n	2	5	6	6
22 Simpson Lagoon	n	n	n	n	2	15	n	1	5	8	10	10
23 Gwydyr Bay	n	n	n	n	1	4	n	2	4	5	6	6
24 ERA 24	n	n	n	n	1	8	n	1	4	7	8	8
25 Prudhoe Bay	n	n	1	1	2	6	1	4	6	7	7	7
26 ERA 26	n	1	1	2	3	11	2	9	13	14	14	14
27 ERA 27	n	1	1	1	2	9	6	14	17	18	18	18
28 ERA 28	n	n	1	3	6	23	1	7	11	12	12	12
29 ERA 29	n	n	1	1	2	12	n	3	8	11	12	12
30 ERA 30	n	1	1	2	3	11	0	6	12	14	14	15
31 ERA 31	n	n	1	2	3	13	0	4	8	10	10	10
32 Water surface over Boulder Patch 1	n	1	3	5	8	28	7	18	21	22	23	23
33 Water surface over Boulder Patch 2	3	4	6	9	15	50	39	48	50	51	51	51
34 ERA 34	1	1	1	1	2	4	8	13	15	15	15	15
35 ERA 35	33	33	33	33	33	>99.5	>99.5	>99.5	>99.5	>99.5	>99.5	>99.5
36 ERA 36	1	2	2	4	6	19	12	15	17	18	18	18
37 ERA 37	2	2	4	6	9	31	10	16	17	18	19	19
38 ERA 38	1	1	2	3	4	14	6	11	13	14	14	14
39 ERA 39	n	1	2	3	5	17	1	8	14	17	18	18
40 ERA 40	n	1	2	3	4	16	n	4	11	13	15	15
41 ERA 41	n	n	1	1	2	9	n	1	6	9	10	10
42 Canning River	n	n	n	n	1	4	n	1	2	3	4	4
43 ERA43	n	n	n	1	1	7	n	1	4	8	9	9
44 Simpson Cove	n	n	n	n	n	3	n	n	1	2	2	2
45 ERA45	n	n	n	1	1	3	n	n	3	5	6	6
46 Arey Lagoon, Hula Hula River	n	n	n	n	n	2	n	n	1	1	2	2
47 Whaling Area/Kaktovik	n	n	n	n	n	2	n	n	2	3	4	4
48 Thetis Island	n	n	n	n	1	5	n	n	1	1	2	2
49 Spy Island	n	n	n	n	1	6	n	n	1	2	3	3
50 Leavitt and Pingok Islands	n	n	n	1	1	10	n	n	3	4	4	5
51 Bertoncini, Bodfish, and Cottle	n	n	n	1	2	17	n	2	6	8	9	9
52 Long Island	n	n	n	1	2	11	n	3	7	9	10	10
53 Egg and Stump Islands	n	n	1	1	2	8	n	5	9	10	10	10
54 West Dock	n	n	1	2	3	12	n	6	9	10	10	10
55 Reindeer and Argo Islands	n	n	1	1	2	10	n	3	7	8	8	8
56 Cross and No Name Islands	n	n	1	2	3	12	n	2	6	7	8	8
57 Endicott Causeway	1	1	2	2	4	13	10	18	21	21	22	22
58 Narwhal, Jeanette and Karluk	1	2	3	4	6	19	5	12	14	16	16	16
59 Tigvariak Island	1	2	2	3	5	15	10	15	17	17	18	18
60 Pole and Belvedere Islands	1	1	2	3	5	16	2	7	9	11	12	12
61 Challenge, Alaska, Duchess a	n	1	1	2	3	12	1	3	6	7	8	8
62 Flaxman Island	n	n	n	1	1	8	n	2	4	5	6	6

Note: n = Less than 0.5%

Table A-16 Conditional Probabilities (Expressed as Percent Chance) That an Oil Spill Starting at PP1 or PP2 in Summer Will Contact a Certain Environmental Resource Area (ERA) Within 1, 3, 10, 30, 60, Or 360 Days, Proposed Pipeline

ERA	PP1 Summer (Days)						PP2 Summer (Days)					
	1	3	10	30	60	360	1	3	10	30	60	360
LAND All Land Segments	34	59	78	88	94	94	54	72	86	94	97	97
1 Spring Lead 1	n	n	n	n	n	n	n	n	n	n	n	n
2 Spring Lead 2	n	n	n	n	n	n	n	n	n	n	n	n
3 Spring Lead 3	n	n	n	n	n	n	n	n	n	n	n	n
4 Spring Lead 4	n	n	n	n	n	n	n	n	n	n	n	n
5 Spring Lead 5	n	n	n	n	n	n	n	n	n	n	n	n
6 Ice/Sea Segment 6	n	n	n	n	n	1	n	n	n	n	n	1
7 Ice/Sea Segment 7	n	n	1	2	3	3	n	n	1	1	2	2
8 Ice/Sea Segment 8	n	n	1	1	1	1	n	n	n	n	1	1
9 Ice/Sea Segment 9	n	n	3	3	4	4	n	n	2	2	2	2
10 Ice/Sea Segment 10	n	1	3	4	4	5	n	n	1	3	3	3
11 Ice/Sea Segment 11	n	1	5	7	7	7	n	n	2	3	4	4
12 Ice/Sea Segment 12	n	n	1	3	3	3	n	n	n	1	1	1
13 Ice/Sea Segment 13	n	n	1	3	3	3	n	n	1	2	2	2
14 ERA 14	n	n	n	n	n	n	n	n	n	n	n	n
15 ERA 15	n	n	n	n	n	n	n	n	n	n	n	n
16 ERA 16	n	n	n	n	1	1	n	n	n	n	n	n
17 ERA 17	n	n	1	1	1	1	n	n	1	1	1	1
18 ERA 18	n	n	n	1	1	1	n	n	n	1	1	1
19 ERA 19	n	n	n	2	2	2	n	n	1	2	2	2
20 ERA 20	n	n	1	3	4	4	n	n	1	2	2	2
21 ERA 21	n	n	2	5	6	6	n	n	n	3	3	3
22 Simpson Lagoon	n	1	5	7	9	9	n	1	3	5	6	6
23 Gwyder Bay	n	2	4	5	5	5	n	n	3	3	3	3
24 ERA 24	n	1	3	5	7	7	n	n	2	4	4	4
25 Prudhoe Bay	2	4	6	6	7	7	n	2	3	3	4	4
26 ERA 26	3	9	12	12	13	13	n	6	8	8	8	8
27 ERA 27	9	15	17	17	18	18	2	8	10	10	10	10
28 ERA 28	1	6	9	9	10	10	1	3	5	6	6	6
29 ERA 29	n	3	7	9	10	10	n	2	5	6	6	6
30 ERA 30	n	6	10	12	13	13	n	3	7	8	8	8
31 ERA 31	n	4	7	8	8	8	n	4	7	7	7	7
32 Water surface over Boulder Patch 1	7	13	16	17	17	17	2	9	12	12	12	12
33 Water surface over Boulder Patch 2	47	53	54	54	54	54	12	18	19	20	20	20
34 ERA 34	15	20	21	22	22	22	50	51	52	52	52	52
35 ERA 35	13	18	18	19	20	20	4	7	8	9	9	9
36 ERA 36	19	22	24	24	24	24	15	18	19	19	19	19
37 ERA 37	5	8	10	10	11	11	3	6	7	7	8	8
38 ERA 38	4	10	11	12	12	12	1	3	4	5	5	5
39 ERA 39	1	6	11	13	14	14	n	3	5	7	7	7
40 ERA 40	n	3	8	10	11	11	n	2	4	6	6	6
41 ERA 41	n	1	5	7	8	8	n	n	3	5	5	5
42 Canning River	n	n	1	2	2	2	n	n	1	1	2	2
43 ERA43	n	n	3	5	6	6	n	n	2	2	3	3
44 Simpson Cove	n	n	n	1	1	1	n	n	n	n	n	n
45 ERA45	n	n	2	4	4	4	n	n	2	2	2	3
46 Arey Lagoon, Hula Hula River	n	n	n	1	1	1	n	n	n	n	1	1
47 Whaling Area/Kaktovik	n	n	1	2	3	3	n	n	1	1	2	2
48 Thetis Island	n	n	1	1	2	2	n	n	1	1	1	1
49 Spy Island	n	n	1	2	2	2	n	n	1	2	2	2
50 Leavitt and Pingok Islands	n	n	2	3	3	3	n	1	2	2	3	3
51 Bertoncini, Bodfish and Cottle	n	2	6	7	8	8	n	1	4	5	5	5
52 Long Island	n	2	6	7	8	8	n	1	4	5	5	5
53 Egg and Stump Islands	1	5	8	9	9	9	n	2	5	5	6	6
54 West Dock	1	6	8	8	8	8	n	2	4	4	5	5
55 Reindeer and Argo Islands	n	3	6	7	7	7	n	1	3	4	4	4
56 Cross and No Name Islands	n	2	6	7	7	7	n	2	4	5	5	5
57 Endicott Causeway	15	20	22	22	22	22	10	14	15	16	16	16
58 Narwhal, Jeanette and Karluk	4	9	10	12	12	12	1	6	7	7	8	8
59 Tigvariak Island	11	16	17	18	18	18	7	11	12	12	12	12
60 Pole and Belvedere Islands	1	5	8	9	9	9	1	4	6	6	7	7
61 Challenge, Alaska, Dutchess a	n	2	4	5	6	6	n	2	3	3	4	4
62 Flaxman Island	n	1	2	3	4	4	n	n	1	1	1	1

Note: n = Less than 0.5%

Table A-17 Conditional Probabilities (Expressed as Percent Chance) That an Oil Spill Starting At PP1 or PP2 in Winter Will Contact a Certain Environmental Resource Area (ERA) Within 1, 3, 10, 30, 60, or 360 Days, Proposed Pipeline

ERA	PP1 Winter (Days)						PP2 Winter (Days)					
	1	3	10	30	60	360	1	3	10	30	60	360
LAND All Land Segments	2	5	8	14	24	98	5	7	9	16	26	99
1 Spring Lead 1	n	n	n	n	n	n	n	n	n	n	n	n
2 Spring Lead 2	n	n	n	n	n	n	n	n	n	n	n	n
3 Spring Lead 3	n	n	n	n	n	n	n	n	n	n	n	n
4 Spring Lead 4	n	n	n	n	n	n	n	n	n	n	n	n
5 Spring Lead 5	n	n	n	n	n	n	n	n	n	n	n	n
6 Ice/Sea Segment 6	n	n	n	n	n	1	n	n	n	n	n	1
7 Ice/Sea Segment 7	n	n	n	n	1	1	n	n	n	n	n	1
8 Ice/Sea Segment 8	n	n	n	1	1	1	n	n	n	n	1	1
9 Ice/Sea Segment 9	n	n	1	1	2	4	n	n	1	1	1	3
10 Ice/Sea Segment 10	n	n	1	2	2	4	n	n	1	1	1	3
11 Ice/Sea Segment 11	n	n	1	1	1	5	n	n	1	1	1	4
12 Ice/Sea Segment 12	n	n	n	n	1	1	n	n	n	n	n	n
13 Ice/Sea Segment 13	n	n	n	n	n	n	n	n	n	n	n	n
14 ERA 14	n	n	n	n	n	n	n	n	n	n	n	n
15 ERA 15	n	n	n	n	n	n	n	n	n	n	n	n
16 ERA 16	n	n	n	n	n	2	n	n	n	n	n	1
17 ERA 17	n	n	n	n	n	4	n	n	n	n	n	4
18 ERA 18	n	n	n	n	1	3	n	n	n	n	n	3
19 ERA 19	n	n	n	n	n	2	n	n	n	n	n	2
20 ERA 20	n	n	n	n	1	4	n	n	n	n	1	3
21 ERA 21	n	n	n	n	1	7	n	n	n	n	1	4
22 Simpson Lagoon	n	n	n	n	1	13	n	n	n	n	1	9
23 Gwydyr Bay	n	n	n	n	n	1	n	n	n	1	1	4
24 ERA 24	n	n	n	n	1	8	n	n	n	n	1	4
25 Prudhoe Bay	n	n	1	1	1	5	n	n	n	n	1	3
26 ERA 26	n	n	1	1	2	9	n	n	1	2	4	15
27 ERA 27	n	1	1	2	3	13	n	1	1	2	4	14
28 ERA 28	n	1	1	3	5	17	n	n	1	2	4	17
29 ERA 29	n	n	n	1	1	8	n	n	n	1	1	5
30 ERA 30	n	1	1	2	3	9	n	n	1	1	2	7
31 ERA 31	n	n	1	1	2	10	n	n	1	1	2	7
32 Water surface over Boulder Patch 1	1	1	2	4	6	21	n	1	2	3	5	18
33 Water surface over Boulder Patch 2	5	5	7	11	17	58	2	3	4	6	9	33
34 ERA 34	1	2	2	3	3	10	5	6	7	10	17	55
35 ERA 35	2	3	4	7	10	34	1	2	2	3	5	15
36 ERA 36	2	2	3	5	7	22	2	2	3	6	10	34
37 ERA 37	1	1	2	3	5	20	n	n	1	2	4	16
38 ERA 38	1	1	2	3	4	15	n	1	1	2	2	7
39 ERA 39	n	1	2	3	4	13	n	n	1	2	2	8
40 ERA 40	n	1	2	2	4	15	n	n	1	1	2	6
41 ERA 41	n	n	1	1	1	7	n	n	n	n	1	5
42 Canning River	n	n	n	n	n	3	n	n	n	n	n	1
43 ERA43	n	n	n	1	1	4	n	n	n	n	1	4
44 Simpson Cove	n	n	n	n	n	2	n	n	n	n	n	2
45 ERA45	n	n	n	n	n	2	n	n	n	n	n	1
46 Arey Lagoon, Hula Hula River	n	n	n	n	n	1	n	n	n	n	n	1
47 Whaling Area/Kaktovik	n	n	n	n	n	1	n	n	n	n	n	1
48 Thetis Island	n	n	n	n	1	5	n	n	n	n	1	4
49 Spy Island	n	n	n	n	1	5	n	n	n	n	1	4
50 Leavitt and Pingok Islands	n	n	n	n	1	8	n	n	n	n	1	6
51 Bertoncini, Bodfish, and Cottle	n	n	n	1	2	15	n	n	n	1	2	10
52 Long Island	n	n	n	1	1	7	n	n	n	1	1	6
53 Egg and Stump Islands	n	n	1	1	2	9	n	n	n	1	2	6
54 West Dock	n	n	1	1	2	7	n	n	n	1	1	5
55 Reindeer and Argo Islands	n	n	1	1	2	8	n	n	1	1	2	8
56 Cross and No Name Islands	n	n	1	1	2	7	n	n	n	1	1	5
57 Endicott Causeway	1	1	2	3	5	18	1	1	2	3	6	21
58 Narwhal, Jeanette and Karluk	1	2	2	4	6	19	n	1	1	2	3	8
59 Tigvariak Island	1	2	2	4	6	18	1	1	2	4	6	22
60 Pole and Belvedere Islands	n	1	2	3	5	15	n	1	1	2	2	6
61 Challenge, Alaska, Duchess a	n	n	1	2	3	12	n	n	1	1	2	6
62 Flaxman Island	n	n	n	1	1	5	n	n	n	n	n	1

Note: n = Less than 0.5%

Table A-18 Conditional Probabilities (Expressed as Percent Chance) That an Oil Spill Starting at PP1 or PP2 in the Winter Will Contact a Certain Land Segment Within 1, 3, 10, 30, 60, or 360 Days, Proposed Pipeline

Land Segment	PP1 Winter (Days)						PP2 Winter (Days)					
	1	3	10	30	60	360	1	3	10	30	60	360
16	n	n	n	n	n	3	n	n	n	n	n	2
17	n	n	n	n	n	2	n	n	n	n	n	2
18	n	n	n	n	n	1	n	n	n	n	n	1
19	n	n	n	n	n	1	n	n	n	n	n	1
20	n	n	n	n	n	1	n	n	n	n	n	1
21	n	n	n	n	1	7	n	n	n	n	1	4
22	n	n	n	n	n	2	n	n	n	1	1	3
23	n	n	1	1	2	8	n	n	n	n	1	3
24	n	n	n	1	1	3	n	n	n	n	n	2
25	n	1	1	2	3	9	n	1	1	2	2	8
26	1	2	3	5	9	30	5	6	7	10	15	46
27	n	1	2	2	4	12	n	n	1	2	3	10
28	n	n	1	1	2	7	n	n	1	1	3	10
29	n	n	n	1	1	6	n	n	n	n	n	2
30	n	n	n	n	n	2	n	n	n	n	n	1
31	n	n	n	n	n	1	n	n	n	n	n	n
32	n	n	n	n	n	3	n	n	n	n	n	2
33	n	n	n	n	n	1	n	n	n	n	n	2

Note: n = Less than 0.5% Land Segments 16 through 33 are shown.
All other Land Segments with all values less than 0.5% are not shown

Table A-19 Conditional Probabilities (Expressed as Percent Chance) That an Oil Spill Starting at PP1 or PP2 in the Summer will Contact a Certain Land Segment Within 1, 3, 10, 30, 60, or 360 Days, Proposed Pipeline

Land Segment	PP1 Summer (Days)						PP2 Summer (Days)					
	1	3	10	30	60	360	1	3	10	30	60	360
16	n	n	n	n	1	1	n	N	n	n	n	n
17	n	n	n	n	n	n	n	N	n	n	n	n
18	n	n	n	n	n	n	n	N	n	n	n	n
19	n	n	n	1	1	1	n	N	n	n	1	1
20	n	n	n	n	1	1	n	N	n	1	1	1
21	n	1	2	3	4	4	n	N	1	2	2	2
22	n	1	3	4	4	4	n	N	3	3	3	3
23	n	3	5	5	6	6	n	1	2	3	3	3
24	n	2	3	4	4	4	n	N	1	2	2	2
25	5	9	11	12	12	12	6	9	12	12	12	12
26	23	29	32	33	33	33	46	53	55	55	55	55
27	5	8	9	10	10	10	1	4	5	5	5	5
28	1	5	6	7	7	7	1	5	6	6	7	7
29	n	1	2	3	3	3	n	N	1	1	1	1
30	n	1	1	2	2	2	n	N	n	1	1	1
31	n	n	n	1	1	1	n	N	n	1	1	1
32	n	n	n	1	1	2	n	N	n	n	1	1
33	n	n	1	1	1	2	n	N	n	1	1	1
34	n	n	n	1	1	1	n	N	1	1	1	1

Note: n = Less than 0.5% Land Segments 16 through 34 are shown.
All other Land Segments with all values less than 0.5% are not shown

Table A-20 Conditional Probabilities (Expressed as Percent Chance) That an Oil Spill Starting at AP1 or AP2 in Summer Will Contact a Certain Environmental Resource Area (ERA) Within 1, 3, 10, 30, 60, Or 360 Days, Eastern Alternative Pipeline

ERA	AP1 Summer (Days)						AP2 Summer (Days)					
	1	3	10	30	60	360	1	3	10	30	60	360
LAND All Land Segments	32	59	78	88	94	94	48	70	85	92	95	96
1 Spring Lead 1	n	n	n	n	n	n	n	n	n	n	n	n
2 Spring Lead 2	n	n	n	n	n	n	n	n	n	n	n	n
3 Spring Lead 3	n	n	n	n	n	n	n	n	n	n	n	n
4 Spring Lead 4	n	n	n	n	n	n	n	n	n	n	n	n
5 Spring Lead 5	n	n	n	n	n	n	n	n	n	n	n	n
6 Ice/Sea Segment 6	n	n	n	n	n	1	n	n	n	n	n	1
7 Ice/Sea Segment 7	n	n	1	2	3	3	n	n	1	2	2	2
8 Ice/Sea Segment 8	n	n	1	1	1	1	n	n	n	n	1	1
9 Ice/Sea Segment 9	n	n	3	3	4	4	n	n	2	2	2	2
10 Ice/Sea Segment 10	n	1	2	4	4	4	n	n	2	3	3	3
11 Ice/Sea Segment 11	n	1	5	6	7	7	n	1	3	4	5	5
12 Ice/Sea Segment 12	n	n	1	3	3	3	n	n	1	2	2	2
13 Ice/Sea Segment 13	n	n	1	3	3	3	n	n	1	2	2	2
14 ERA 14	n	n	n	n	n	n	n	n	n	n	n	n
15 ERA 15	n	n	n	n	n	n	n	n	n	n	n	n
16 ERA 16	n	n	n	n	1	1	n	n	n	n	n	n
17 ERA 17	n	n	1	1	1	1	n	n	1	1	1	1
18 ERA 18	n	n	n	1	1	1	n	n	n	1	1	1
19 ERA 19	n	n	n	2	2	2	n	n	1	2	2	2
20 ERA 20	n	n	1	3	4	4	n	n	1	3	3	3
21 ERA 21	n	n	2	4	5	5	n	n	1	3	3	3
22 Simpson Lagoon	n	1	5	7	9	9	n	n	3	4	5	5
23 Gwydyr Bay	n	2	4	5	5	5	n	1	4	4	4	4
24 ERA 24	n	1	3	5	7	7	n	n	2	4	4	4
25 Prudhoe Bay	2	4	5	6	6	6	n	2	4	4	4	4
26 ERA 26	2	9	11	12	12	12	1	6	9	9	9	9
27 ERA 27	8	15	17	17	18	18	3	9	11	12	12	12
28 ERA 28	1	5	8	9	9	10	1	3	6	6	6	6
29 ERA 29	n	3	7	9	10	10	n	1	4	6	6	6
30 ERA 30	n	5	10	12	12	12	n	2	7	8	8	8
31 ERA 31	n	3	7	8	8	9	n	3	6	7	7	7
32 Water surface over Boulder Patch 1	6	13	16	16	17	17	2	9	12	12	12	12
33 Water surface over Boulder Patch 2	36	42	44	45	45	45	9	16	18	19	19	19
34 ERA 34	13	17	19	19	19	19	29	32	33	33	33	33
35 ERA 35	19	22	23	24	24	24	5	9	10	11	11	11
36 ERA 36	21	25	26	27	27	27	36	39	40	40	40	40
37 ERA 37	6	10	11	12	13	13	3	6	7	8	8	8
38 ERA 38	5	11	12	13	13	13	2	5	6	6	6	6
39 ERA 39	1	6	11	14	15	15	n	4	6	8	8	8
40 ERA 40	n	4	8	11	11	12	n	3	6	8	8	8
41 ERA 41	n	1	4	7	8	8	n	1	4	6	6	6
42 Canning River	n	n	1	2	2	2	n	n	1	2	2	2
43 ERA43	n	n	3	5	6	6	n	n	2	4	4	5
44 Simpson Cove	n	n	n	1	1	1	n	n	n	n	1	1
45 ERA45	n	n	2	4	4	5	n	n	2	3	4	4
46 Arey Lagoon, Hula Hula River	n	n	n	1	1	1	n	n	n	1	1	1
47 Whaling Area/Kaktovik	n	n	1	2	3	3	n	n	2	2	2	2
48 Thetis Island	n	n	1	1	2	2	n	n	1	1	2	2
49 Spy Island	n	n	1	2	2	2	n	n	1	2	2	2
50 Leavitt and Pingok Islands	n	n	2	3	4	4	n	1	2	3	3	3
51 Bertoncini, Bodfish, and Cottle	n	2	5	7	8	8	n	1	3	5	5	5
52 Long Island	n	2	6	7	7	7	n	1	4	4	5	5
53 Egg and Stump Islands	n	5	9	9	10	10	n	2	6	6	6	6
54 West Dock	1	6	8	8	9	9	n	3	5	5	6	6
55 Reindeer and Argo Islands	n	3	6	7	7	7	n	1	3	4	4	4
56 Cross and No Name Islands	n	3	5	6	7	7	n	2	4	4	5	5
57 Endicott Causeway	13	18	20	20	21	21	9	14	16	16	16	16
58 Narwhal, Jeanette and Karluk	4	9	10	12	12	12	1	5	7	8	8	8
59 Tigvariak Island	13	18	20	21	21	21	13	18	19	19	20	20
60 Pole and Belvedere Islands	2	6	8	10	10	10	2	6	7	8	8	8
61 Challenge, Alaska, Duchess a	n	2	4	5	6	6	n	2	4	5	5	5
62 Flaxman Island	n	1	2	3	4	4	n	n	1	2	2	2

Note: n = Less than 0.5%

Table A-21 Conditional Probabilities (Expressed as Percent Chance) That an Oil Spill Starting at AP1 or AP2 in Winter Will Contact a Certain Environmental Resource Area (ERA) Within 1, 3, 10, 30, 60 or 360 Days, Eastern Alternative Pipeline

ERA	AP1 Winter (Days)						AP2 Winter (Days)					
	1	3	10	30	60	360	1	3	10	30	60	360
LAND All Land Segments	2	5	8	14	23	98	4	7	9	16	26	99
1 Spring Lead 1	n	n	n	n	n	n	n	n	n	n	n	n
2 Spring Lead 2	n	n	n	n	n	n	n	n	n	n	n	n
3 Spring Lead 3	n	n	n	n	n	n	n	n	n	n	n	n
4 Spring Lead 4	n	n	n	n	n	n	n	n	n	n	n	n
5 Spring Lead 5	n	n	n	n	n	n	n	n	n	n	n	n
6 Ice/Sea Segment 6	n	n	n	n	n	1	n	n	n	n	n	1
7 Ice/Sea Segment 7	n	n	n	n	1	1	n	n	n	n	n	1
8 Ice/Sea Segment 8	n	n	n	1	1	1	n	n	n	n	1	1
9 Ice/Sea Segment 9	n	n	1	1	2	4	n	n	1	1	1	2
10 Ice/Sea Segment 10	n	n	1	2	2	4	n	n	1	1	1	2
11 Ice/Sea Segment 11	n	n	1	1	1	6	n	n	1	1	1	6
12 Ice/Sea Segment 12	n	n	n	n	n	1	n	n	n	n	n	n
13 Ice/Sea Segment 13	n	n	n	n	n	n	n	n	n	n	n	n
14 ERA 14	n	n	n	n	n	n	n	n	n	n	n	n
15 ERA 15	n	n	n	n	n	n	n	n	n	n	n	n
16 ERA 16	n	n	n	n	n	2	n	n	n	n	n	n
17 ERA 17	n	n	n	n	n	3	n	n	n	n	n	2
18 ERA 18	n	n	n	n	n	3	n	n	n	n	n	1
19 ERA 19	n	n	n	n	n	2	n	n	n	n	n	1
20 ERA 20	n	n	n	n	1	4	n	n	n	n	n	1
21 ERA 21	n	n	n	n	1	6	n	n	n	n	n	2
22 Simpson Lagoon	n	n	n	n	1	12	n	n	n	n	1	7
23 Gwydyr Bay	n	n	n	n	1	3	n	n	n	1	1	4
24 ERA 24	n	n	n	n	1	7	n	n	n	n	n	3
25 Prudhoe Bay	n	n	1	1	1	4	n	n	n	1	1	4
26 ERA 26	n	n	1	2	3	12	n	n	1	2	3	12
27 ERA 27	n	1	1	2	3	14	n	1	1	2	4	15
28 ERA 28	n	1	1	2	4	16	n	n	1	2	3	11
29 ERA 29	n	n	n	1	1	9	n	n	n	n	n	2
30 ERA 30	n	1	1	2	2	9	n	n	1	1	1	3
31 ERA 31	n	n	1	1	2	8	n	n	n	1	1	2
32 Water surface over Boulder Patch 1	1	1	2	4	7	24	n	1	2	3	5	18
33 Water surface over Boulder Patch 2	3	4	5	9	14	48	1	2	3	5	7	23
34 ERA 34	1	2	2	3	4	11	2	3	4	6	10	33
35 ERA 35	3	4	5	8	12	39	1	2	2	3	5	15
36 ERA 36	2	3	3	5	8	25	5	5	6	9	14	45
37 ERA 37	1	2	2	4	6	21	n	1	1	2	3	8
38 ERA 38	1	1	2	3	4	14	1	1	2	2	3	10
39 ERA 39	n	1	2	3	4	14	n	n	1	2	2	8
40 ERA 40	n	1	2	3	4	15	n	1	1	2	2	7
41 ERA 41	n	n	1	1	2	8	n	n	1	1	1	6
42 Canning River	n	n	n	n	n	3	n	n	n	n	n	1
43 ERA43	n	n	n	1	1	6	n	n	n	n	1	4
44 Simpson Cove	n	n	n	n	n	3	n	n	n	n	n	2
45 ERA45	n	n	n	n	1	2	n	n	n	n	n	2
46 Arey Lagoon, Hula Hula River	n	n	n	n	n	1	n	n	n	n	n	2
47 Whaling Area/Kaktovik	n	n	n	n	n	2	n	n	n	n	n	1
48 Thetis Island	n	n	n	n	1	4	n	n	n	n	n	2
49 Spy Island	n	n	n	n	1	4	n	n	n	n	n	2
50 Leavitt and Pingok Islands	n	n	n	n	1	7	n	n	n	n	n	3
51 Bertoncini, Bodfish, and Cottle	n	n	n	1	2	13	n	n	n	n	1	7
52 Long Island	n	n	n	1	1	6	n	n	n	n	1	3
53 Egg and Stump Islands	n	n	1	1	3	11	n	n	n	1	2	7
54 West Dock	n	n	1	1	2	9	n	n	n	1	2	9
55 Reindeer and Argo Islands	n	n	1	1	1	5	n	n	n	1	1	4
56 Cross and No Name Islands	n	n	1	1	2	8	n	n	n	n	n	1
57 Endicott Causeway	1	1	2	3	4	16	n	1	1	2	4	13
58 Narwhal, Jeanette and Karluk	n	2	2	3	4	12	n	1	1	1	1	3
59 Tigvariak Island	1	2	3	4	6	19	2	2	3	5	8	26
60 Pole and Belvedere Islands	n	1	2	3	5	16	n	1	2	3	3	9
61 Challenge, Alaska, Duchess a	n	n	1	2	3	12	n	1	1	1	2	7
62 Flaxman Island	n	n	n	1	1	7	n	n	n	n	n	2

Note: n = Less than 0.5%

Table A-22 Conditional Probabilities (Expressed as Percent Chance) That an Oil Spill Starting at AP1 or AP2 in the Winter Will Contact a Certain Land Segment Within 1, 3, 10, 30, 60, or 360 Days, Eastern Alternative Pipeline

Land Segment	AP1 Winter (Days)						AP2 Winter (Days)					
	1	3	10	30	60	360	1	3	10	30	60	360
16	n	n	n	n	n	2	n	n	n	n	n	1
17	n	n	n	n	n	2	n	n	n	n	n	1
18	n	n	n	n	n	1	n	n	n	n	n	n
19	n	n	n	n	n	1	n	n	n	n	n	1
20	n	n	n	n	n	1	n	n	n	n	n	n
21	n	n	n	n	1	7	n	n	n	n	1	4
22	n	n	n	1	1	4	n	n	n	1	1	4
23	n	n	1	1	2	8	n	n	n	1	1	5
24	n	n	n	1	1	3	n	n	n	n	n	2
25	n	1	1	2	3	9	n	1	1	1	2	6
26	1	2	3	5	8	28	4	5	6	8	12	38
27	n	1	1	2	4	14	n	1	1	3	5	20
28	n	n	1	1	2	8	n	1	1	1	2	8
29	n	n	n	n	1	4	n	n	n	n	1	4
30	n	n	n	n	n	3	n	n	n	n	n	1
31	n	n	n	n	n	1	n	n	n	n	n	n
32	n	n	n	n	n	3	n	n	n	n	n	2
33	n	n	n	n	n	2	n	n	n	n	n	3
34	n	n	n	n	n	1	n	n	n	n	n	n

Note: n = Less than 0.5% Land Segments 16 through 34 are shown.
All other Land Segments with all values less than 0.5% are not shown

Table A-23 Conditional Probabilities (Expressed as Percent Chance) That an Oil Spill Starting at AP1 or AP2 in the Summer Will Contact a Certain Land Segment Within 1, 3, 10, 30, 60, or 360 Days, Eastern Alternative Pipeline

Land Segment	AP1 Summer (Days)						AP2 Summer (Days)					
	1	3	10	30	60	360	1	3	10	30	60	360
16	n	n	n	n	1	1	n	n	n	n	n	n
17	n	n	n	n	n	n	n	n	n	n	n	n
18	n	n	n	n	n	n	n	n	n	n	1	1
19	n	n	n	n	1	1	n	n	n	n	1	1
20	n	n	n	n	1	1	n	n	n	n	1	1
21	n	1	2	3	4	4	n	n	1	2	2	2
22	n	1	4	5	5	5	n	n	3	4	4	4
23	n	3	5	5	5	5	n	1	3	3	3	3
24	n	2	3	4	4	4	n	n	2	2	2	2
25	4	9	11	12	12	12	4	8	9	10	10	10
26	20	27	29	30	30	30	38	45	47	47	47	47
27	7	11	12	13	13	13	4	8	9	10	10	10
28	2	6	7	8	8	8	2	6	8	8	8	8
29	n	1	2	3	3	3	n	n	1	1	2	2
30	n	n	1	1	2	2	n	n	n	1	1	1
31	n	n	n	1	1	1	n	n	n	1	1	1
32	n	n	n	1	1	1	n	n	n	n	n	n
33	n	n	1	1	2	2	n	n	n	1	1	1
34	n	n	n	1	1	1	n	n	1	1	1	1

Note: n = Less than 0.5% Land Segments 16 through 34 are shown.
All other Land Segments with all values less than 0.5% are not shown

Table A-24 Conditional Probabilities (Expressed as Percent Chance) That an Oil Spill Starting at TP1 or TP2 in Summer Will Contact a Certain Environmental Resource Area (ERA) Within 1, 3, 10, 30, 60, Or 360 Days, Tern Island Alternative Pipeline

ERA	TP1 Summer (Days)						TP2 Summer (Days)					
	1	3	10	30	60	360	1	3	10	30	60	360
LAND All Land Segments	30	58	77	88	94	94	48	70	84	92	95	96
1 Spring Lead 1	n	n	n	n	n	n	n	n	n	n	n	n
2 Spring Lead 2	n	n	n	n	n	n	n	n	n	n	n	n
3 Spring Lead 3	n	n	n	n	n	n	n	n	n	n	n	n
4 Spring Lead 4	n	n	n	n	n	n	n	n	n	n	n	n
5 Spring Lead 5	n	n	n	n	n	n	n	n	n	n	n	n
6 Ice/Sea Segment 6	n	n	n	n	n	1	n	n	n	n	n	1
7 Ice/Sea Segment 7	n	n	1	2	3	3	n	n	1	2	2	2
8 Ice/Sea Segment 8	n	n	1	1	1	1	n	n	n	n	1	1
9 Ice/Sea Segment 9	n	n	2	3	3	3	n	n	2	2	2	2
10 Ice/Sea Segment 10	n	n	2	4	4	5	n	n	2	3	3	3
11 Ice/Sea Segment 11	n	1	5	7	7	7	n	1	3	5	5	5
12 Ice/Sea Segment 12	n	n	1	3	3	3	n	n	1	2	2	2
13 Ice/Sea Segment 13	n	n	1	3	3	3	n	n	1	2	2	2
14 ERA 14	n	n	n	n	n	n	n	n	n	n	n	n
15 ERA 15	n	n	n	n	n	n	n	n	n	n	n	n
16 ERA 16	n	n	n	n	1	1	n	n	n	n	n	n
17 ERA 17	n	n	1	1	1	1	n	n	1	1	1	1
18 ERA 18	n	n	n	1	1	1	n	n	n	1	1	1
19 ERA 19	n	n	n	2	2	2	n	n	1	2	2	2
20 ERA 20	n	n	1	3	3	4	n	n	1	3	3	3
21 ERA 21	n	n	2	4	5	5	n	n	1	3	3	3
22 Simpson Lagoon	n	1	4	6	8	8	n	n	3	4	5	5
23 Gwydyr Bay	n	1	5	5	5	5	n	1	4	4	4	4
24 ERA 24	n	1	3	5	7	7	n	n	2	4	5	5
25 Prudhoe Bay	1	4	5	6	6	6	n	2	4	4	4	4
26 ERA 26	2	9	12	13	13	13	1	6	9	9	9	9
27 ERA 27	6	14	16	17	17	17	3	9	11	11	11	11
28 ERA 28	1	5	9	10	10	10	1	3	6	6	6	6
29 ERA 29	n	2	7	9	10	10	n	1	4	6	6	6
30 ERA 30	n	4	10	12	12	12	n	2	7	8	8	8
31 ERA 31	n	3	7	9	9	9	n	3	6	6	7	7
32 Water surface over Boulder Patch 1	4	13	16	17	17	17	1	9	12	12	12	12
33 Water surface over Boulder Patch 2	32	38	41	42	42	42	9	15	18	18	18	18
34 ERA 34	11	15	17	17	17	17	27	30	31	31	31	31
35 ERA 35	28	31	31	32	32	32	5	9	10	10	10	10
36 ERA 36	22	26	27	28	28	28	>99.5	>99.5	>99.5	>99.5	>99.5	>99.5
37 ERA 37	7	11	13	14	14	14	3	6	7	8	8	8
38 ERA 38	7	12	14	14	14	14	3	6	6	7	7	7
39 ERA 39	1	7	12	14	15	15	n	4	6	8	9	9
40 ERA 40	n	4	9	11	12	13	n	4	6	8	8	8
41 ERA 41	n	1	5	8	8	8	n	1	4	6	7	7
42 Canning River	n	n	1	2	2	2	n	n	1	2	2	2
43 ERA43	n	n	3	6	7	7	n	n	2	4	5	5
44 Simpson Cove	n	n	n	1	1	1	n	n	n	n	1	1
45 ERA45	n	n	3	4	5	5	n	n	2	3	4	4
46 Arey Lagoon, Hula Hula River	n	n	n	1	1	1	n	n	n	1	1	1
47 Whaling Area/Kaktovik	n	n	2	2	3	3	n	n	2	2	2	3
48 Thetis Island	n	n	1	1	2	2	n	n	1	1	2	2
49 Spy Island	n	n	1	2	2	2	n	n	1	2	2	2
50 Leavitt and Pingok Islands	n	n	2	3	4	4	n	1	2	3	3	3
51 Bertoncini, Bodfish, and Cottle	n	2	5	7	8	8	n	1	3	5	5	5
52 Long Island	n	2	6	7	7	7	n	1	3	4	4	4
53 Egg and Stump Islands	n	5	9	10	10	10	n	2	6	6	7	7
54 West Dock	n	5	8	9	9	9	n	3	5	5	6	6
55 Reindeer and Argo Islands	n	3	6	6	7	7	n	1	3	4	4	4
56 Cross and No Name Islands	n	2	5	6	6	6	n	2	4	4	5	5
57 Endicott Causeway	11	18	20	20	21	21	8	14	16	16	16	16
58 Narwhal, Jeanette and Karluk	3	9	10	12	12	12	n	5	7	8	8	8
59 Tigvariak Island	14	20	21	22	22	22	15	19	20	21	21	21
60 Pole and Belvedere Islands	3	7	10	11	11	11	2	6	8	8	8	9
61 Challenge, Alaska, Duchess a	n	2	4	5	6	6	n	2	4	5	5	5
62 Flaxman Island	n	1	3	3	4	4	n	n	1	2	2	2

Note: n = Less than 0.5%

Table A-25 Conditional Probabilities (Expressed as Percent Chance) That an Oil Spill Starting at TP1 or TP2 in Winter Will Contact a Certain Environmental Resource Area (ERA) Within 1, 3, 10, 30, 60, Or 360 Days, Tern Island Alternative Pipeline

ERA	TP1 Winter (Days)						TP2 Winter (Days)					
	1	3	10	30	60	360	1	3	10	30	60	360
LAND All Land Segments	2	5	8	14	23	98	4	6	9	16	27	99
1 Spring Lead 1	n	n	n	n	n	n	n	n	n	n	n	n
2 Spring Lead 2	n	n	n	n	n	n	n	n	n	n	n	n
3 Spring Lead 3	n	n	n	n	n	n	n	n	n	n	n	n
4 Spring Lead 4	n	n	n	n	n	n	n	n	n	n	n	n
5 Spring Lead 5	n	n	n	n	n	n	n	n	n	n	n	n
6 Ice/Sea Segment 6	n	n	n	n	n	1	n	n	n	n	n	1
7 Ice/Sea Segment 7	n	n	n	n	1	1	n	n	n	n	n	1
8 Ice/Sea Segment 8	n	n	n	1	1	1	n	n	n	n	1	1
9 Ice/Sea Segment 9	n	n	1	1	2	4	n	n	1	1	1	2
10 Ice/Sea Segment 10	n	1	1	2	2	4	n	n	1	1	1	1
11 Ice/Sea Segment 11	n	n	1	1	1	6	n	n	1	1	1	6
12 Ice/Sea Segment 12	n	n	n	n	n	1	n	n	n	n	n	n
13 Ice/Sea Segment 13	n	n	n	n	n	n	n	n	n	n	n	n
14 ERA 14	n	n	n	n	n	n	n	n	n	n	n	n
15 ERA 15	n	n	n	n	n	n	n	n	n	n	n	n
16 ERA 16	n	n	n	n	n	2	n	n	n	n	n	n
17 ERA 17	n	n	n	n	n	3	n	n	n	n	n	2
18 ERA 18	n	n	n	n	n	3	n	n	n	n	n	1
19 ERA 19	n	n	n	n	n	2	n	n	n	n	n	1
20 ERA 20	n	n	n	n	1	4	n	n	n	n	n	1
21 ERA 21	n	n	n	n	1	6	n	n	n	n	n	2
22 Simpson Lagoon	n	n	n	n	1	13	n	n	n	n	1	6
23 Gwydyr Bay	n	n	n	n	1	3	n	n	n	n	1	4
24 ERA 24	n	n	n	n	1	7	n	n	n	n	n	2
25 Prudhoe Bay	n	n	1	1	1	4	n	n	n	1	1	4
26 ERA 26	n	n	1	2	3	12	n	n	1	2	3	11
27 ERA 27	n	1	1	2	3	13	n	1	1	2	4	15
28 ERA 28	n	n	1	2	4	17	n	n	1	2	3	11
29 ERA 29	n	n	n	1	2	11	n	n	n	n	n	2
30 ERA 30	n	1	1	1	2	9	n	n	1	1	1	2
31 ERA 31	n	n	n	1	2	8	n	n	n	1	1	1
32 Water surface over Boulder Patch 1	n	1	2	4	7	25	n	1	2	3	5	17
33 Water surface over Boulder Patch 2	2	4	5	8	13	46	1	2	3	5	7	24
34 ERA 34	1	1	2	2	3	8	2	3	3	6	9	32
35 ERA 35	4	5	6	9	15	49	1	2	2	3	5	13
36 ERA 36	2	3	3	5	8	25	33	33	33	33	33	>99.5
37 ERA 37	1	2	3	5	8	27	n	1	1	2	3	7
38 ERA 38	1	1	2	3	5	18	1	1	2	2	3	9
39 ERA 39	n	1	2	3	4	14	n	n	1	2	2	7
40 ERA 40	n	1	2	2	3	13	n	1	1	2	2	7
41 ERA 41	n	n	1	1	2	8	n	n	n	1	1	6
42 Canning River	n	n	n	n	1	3	n	n	n	n	n	1
43 ERA43	n	n	n	1	1	6	n	n	n	n	1	4
44 Simpson Cove	n	n	n	n	n	3	n	n	n	n	n	2
45 ERA45	n	n	n	n	1	3	n	n	n	n	n	2
46 Arey Lagoon, Hula Hula River	n	n	n	n	n	1	n	n	n	n	n	2
47 Whaling Area/Kaktovik	n	n	n	n	n	1	n	n	n	n	n	n
48 Thetis Island	n	n	n	n	1	4	n	n	n	n	n	2
49 Spy Island	n	n	n	n	1	4	n	n	n	n	n	2
50 Leavitt and Pingok Islands	n	n	n	n	1	7	n	n	n	n	n	3
51 Bertoncini, Bodfish. and Cottle	n	n	n	1	2	14	n	n	n	n	1	6
52 Long Island	n	n	n	1	1	7	n	n	n	n	1	3
53 Egg and Stump Islands	n	n	1	1	2	9	n	n	n	1	2	7
54 West Dock	n	n	1	1	2	10	n	n	n	1	2	10
55 Reindeer and Argo Islands	n	n	1	1	1	5	n	n	n	1	1	4
56 Cross and No Name Islands	n	n	1	1	2	9	n	n	n	n	n	1
57 Endicott Causeway	1	1	2	3	4	15	n	1	1	2	4	13
58 Narwhal, Jeanette and Karluk	n	2	3	4	11	11	n	1	1	1	1	2
59 Tigvariak Island	1	2	3	4	7	21	2	3	3	5	8	27
60 Pole and Belvedere Islands	n	1	2	4	6	19	n	1	2	2	3	9
61 Challenge, Alaska, Duchess a	n	n	1	2	3	11	n	1	1	2	2	6
62 Flaxman Island	n	n	n	1	1	7	n	n	n	n	1	2

Note: n = Less than 0.5%

Table A-26 Conditional Probabilities (Expressed as Percent Chance) That an Oil Spill Starting at TP1 or TP2 in the Winter Will Contact a Certain Land Segment Within 1, 3, 10, 30, 60, or 360 Days, Tern Island Alternative Pipeline

Land Segment	TP1 Winter (Days)						TP2 Winter (Days)					
	1	3	10	30	60	360	1	3	10	30	60	360
16	n	n	n	n	n	2	n	n	n	n	n	n
17	n	n	n	n	n	2	n	n	n	n	n	1
18	n	n	n	n	n	1	n	n	n	n	n	n
19	n	n	n	n	n	1	n	n	n	n	n	1
20	n	n	n	n	n	1	n	n	n	n	n	n
21	n	n	n	n	1	6	n	n	n	n	1	4
22	n	n	n	n	1	4	n	n	n	1	1	4
23	n	n	1	1	2	8	n	n	n	1	2	6
24	n	n	n	1	1	3	n	n	n	n	n	1
25	n	1	1	2	3	8	n	1	1	1	2	6
26	1	2	3	5	7	24	4	4	5	8	12	36
27	n	1	1	3	5	17	1	1	1	3	6	22
28	n	1	1	1	2	8	n	1	1	1	2	8
29	n	n	n	n	1	3	n	n	n	n	1	4
30	n	n	n	n	1	4	n	n	n	n	n	n
31	n	n	n	n	n	1	n	n	n	n	n	n
32	n	n	n	n	n	2	n	n	n	n	n	2
33	n	n	n	n	n	3	n	n	n	n	n	4
34	n	n	n	n	n	1	n	n	n	n	n	n

Note: n = Less than 0.5% Land Segments 16 through 34 are shown.
All other Land Segments with all values less than 0.5% are not shown

Table A-27 Conditional Probabilities (Expressed as Percent Chance) That an Oil Spill Starting at TP1 or TP2 in the Summer Will Contact a Certain Land Segment Within 1, 3, 10, 30, 60, or 360 Days, Tern Island Alternative Pipeline

Land Segment	TP1 Summer (Days)						TP2 Summer (Days)					
	1	3	10	30	60	360	1	3	10	30	60	360
16	n	n	n	n	n	n	n	n	n	n	n	n
17	n	n	n	n	n	1	1	n	n	n	n	n
18	n	n	n	n	n	n	n	n	n	n	n	n
19	n	n	n	n	n	1	1	n	n	n	1	1
20	n	n	n	n	1	1	1	n	n	n	1	1
21	n	1	2	3	3	3	n	n	1	1	2	2
22	n	1	4	5	6	6	n	n	3	4	4	4
23	n	3	5	5	6	6	n	1	3	3	4	4
24	n	2	2	3	3	3	n	1	2	2	2	2
25	3	8	11	11	12	12	4	8	9	10	10	10
26	18	25	28	28	28	28	36	43	45	45	45	45
27	7	11	13	14	14	14	6	10	11	11	11	11
28	2	6	7	8	8	8	2	7	8	8	8	8
29	n	1	2	3	3	3	n	n	1	1	2	2
30	n	n	1	1	2	2	n	n	n	1	1	1
31	n	n	n	1	1	1	n	n	n	1	1	1
32	n	n	n	1	1	1	n	n	n	n	n	n
33	n	n	n	1	2	2	n	n	n	1	1	1
34	n	n	1	1	1	1	n	n	1	1	1	1

Note: n = Less than 0.5% Land Segments 16 through 34 are shown.
All other Land Segments with all values less than 0.5% are not shown.

Table A-27a: U.S. OCS Platform Spills¹ Greater than or Equal to 1,000 Barrels, 1964-1999

Spill Date	Area and Block (Water Depth, Distance from Shore)	Volume Spilled (bbl)	Cause of Spill
April 8, 1964	Eugene Island 208 (94 feet, 48 miles)	2,559	Freighter struck platform, fire.
October 3, 1964	Total Event:	11,869 ²	Hurricane Hilda.
	Eugene Island 208 (94 feet, 48 miles)	(5,180)	Well blowouts, 3 platforms destroyed.
	Ship Shoal 149 (55 feet, 33 miles)	(5,100)	Well blowout, platform destroyed.
	Ship Shoal 199 (102 feet, 44 miles)	(1,589)	Storage oil loss, platform destroyed.
July 19, 1965	Ship Shoal 29 (15 feet, 7 miles)	1,688 ³	Well blowout.
January 28, 1969	Santa Barbara Channel (190 feet, 6 miles)	80,000	50,000 bbl during blowout phase, subsequent seepage 30,000 bbl, considerable oil on beaches, platform destroyed.
March 16, 1969	Ship Shoal 72 (30 feet, 6 miles)	2,500	Storm, vessel bumped rig and sheared wellhead, well blowout.
February 10, 1970	Main Pass 41 (39 feet, 14 miles)	30,000	Fire, well blowout, platform destroyed, minor amount of oil on beaches.
December 1, 1970	South Timbalier 26 (60 feet, 8 miles)	53,000	Wire line work, well blowout, fire, platform and rigs destroyed, 4 fatalities, 36 injured, minor amount of oil on beaches.
January 9, 1973	West Delta 79 (110 feet, 17 miles)	9,935	Structure supporting oil storage tank bent, tank ruptured.
January 26, 1973	South Pelto, 23 (61 feet, 15 miles)	7,000	Rough seas, stationary storage barge sank.
November 23, 1979	Main Pass 151 (280 feet, 10 miles)	1,500 ⁴	Rough seas, service vessel's propeller cut hole in hull of semisubmersible rig, damaged diesel tank.
November 14, 1980	High Island 206 (60 feet, 27 miles)	1,456	Hurricane Jeanne, saltwater pump shutoff switch failed after ballasting, tank overflowed.

Source: Anderson and LaBelle (2001).

¹Crude oil unless otherwise indicated.

²10/3/64 Hurricane Hilda, 11,689-bbl total spillage (treated as one spill event).

³Condensate.

⁴Diesel.

Table A-27b: U.S. OCS Pipeline Spills¹ Greater than or Equal to 1,000 Barrels, 1964-1999

Spill Date	Area and Block (Water Depth, Distance from Shore)	Volume Spilled (bbl)	Cause of Spill
October 15, 1967	West Delta 73 (168 feet, 22 miles)	160,638	Anchor kinked pipeline, internal corrosion later caused a failure in that section. (12" pipeline).
March 12, 1968	South Timbalier 131 (160 feet, 28 miles)	6,000	Anchor drag damaged pipeline section. (18" pipeline)
February 11, 1969	Main Pass 299 (210 feet, 17 miles)	7,532	Anchor drag damaged pipeline section. (4" pipeline)
May 12, 1973	West Delta 73 (168 feet, 22 miles)	5,000	Internal corrosion, several small leaks discovered. (16" pipeline)
April 17, 1974	Eugene Island 317 (240 feet, 75 miles)	19,833	Anchor drag caused pipeline break. (14" pipeline)
September 11, 1974	Main Pass 73 (141 feet, 9 miles)	3,500	Hurricane Carmen, connection torn loose. (8" pipeline).
December 18, 1976	Eugene Island 297 (210 feet, 71 miles)	4,000	Trawl drag pulled valve loose (tie-in between. (14" and 10" pipeline).
December 11, 1981	South Pass 60 (185 feet, 4 miles)	5,100	Service vessel's anchor damaged pipeline. (8" pipeline)
February 7, 1988	Galveston 2A (75 feet, 34 miles)	15,576	Vessel illegally dropped anchor and dragged it along bottom, ruptured pipeline. (14" pipeline)
January 24, 1990	Ship Shoal 281 (197 feet, 60 miles)	14,423 ²	Anchor drag, flange and valve broke off. (4" pipeline).
May 6, 1990	Eugene Island 314 (230 feet, 78 miles)	4,569	Trawl drag pulled off valve (tie-in between 8" and 20" pipeline).
August 31, 1992	South Pelto 8 (30 feet, 6 miles)	2,000	Hurricane Andrew, loose drilling rig's anchor drag damaged pipeline ³ , moderate amount of oil on shoreline (20" pipeline).
November 16, 1994	Ship Shoal 281 (197 feet, 60 miles)	4,533 ²	Trawl drag. (4" pipeline)
January 26, 1998	East Cameron 334 (264 feet, 105 miles)	1,211 ²	Service vessel's anchor drag damaged pipeline during rescue operation. (16" pipeline)
September 29, 1998	South Pass 38 (110 feet, 6 miles)	8,212	Hurricane George mudslide parted pipeline, small amount of oil on shoreline (10" pipeline).
July 23, 1999	Ship Shoal 281 (133 feet, 50 miles)	3,200	Jackup barge sat on pipeline. (12" pipeline)

Source: Anderson and LaBelle (2001).

¹Crude oil unless otherwise indicated.²Condensate.³Pipeline had been shut in for hurricane, leak occurred when pipeline restarted.

Table A-27c Alaska North Slope Facility and Pipeline Crude Oil Spills Greater than or Equal to 500 Barrels from 1985-2000

Spill Date	Facility Type	Facility Operator	Oil Type	Spill Location	Spill Cause	Low Spill Quantity (Barrels)	High Spill Quantity (Barrels)
28-Jul-89	Production Processing	Conoco, Inc.	Crude Oil	Milne Point Unit, Central Processing Facility	Facility Tank Leak–overfill	825	925
25-Aug-89	Pipeline	ARCO Alaska, Inc.	Crude Oil	Kuparuk River Unit, Drill Site 2-U	Pipeline Leak–corrosion of block valve	340	603
10-Dec-90	Production Well Site	ARCO Alaska, Inc.	Crude Oil	Lisburne Unit, Drill Site L-5	Facility Explosion		600
17-Aug-93	Production Processing	ARCO Alaska, Inc.	Crude Oil/ Produced Water	Kuparuk River Unit CPF 1	Tank Leak–Corrosion		675
26-Sep-93	Production Processing	BP Exploration (Alaska)	Crude Oil	Prudhoe Bay Unit, Gathering Center 2	Facility Tank Leak–overflow due to pump failure		650
21-Aug-00	Production Processing	BP Exploration (Alaska)	Crude Oil/ Produced Water	Prudhoe Bay Unit, Gathering Center 2	Facility Tank Leak–overflow due to control system failure	700	715

Source: Hart Crowser (2000), BP Alaska Exploration (2001), and State of Alaska, DEC (2001).

Table A-27d. Trans Alaska Pipeline Spills Greater than or Equal to 500 Barrels based on Reported Quantity High from June 1977 to December 1999

Record Source	Spill Date	Facility Type	Facility Operator	Spill Name	Oil Type	Spill Location	Spill Cause	Low Spill Quantity (Barrels)	High Spill Quantity (Barrels)
APSC–1 ADEC–2 UNK–3 JPO–5	08-Jul-77	Pipeline	APSC	Pump Station 8	Crude Oil	TAPS Pump Station 8 (TAPS MP 489.2)	Facility Explosion ^{1,2,3} Unspecified ⁵	300 ^{1,2,3,5}	4762 ²
APSC–1 ADEC–2 UNK–3 JPO–5	19-Jul-77	Pipeline	APSC	Check Valve 7	Crude Oil	TAPS MP 26 (Check Valve 7)	Pipeline Leak – equipment damage ^{1,2,3} Human Error ⁵	1000 ^{1,2,3,5}	1800 ¹ 2620 ²
APSC–1 UNK–3 JPO–5	15-Feb-78	Pipeline	APSC	Steele Creek	Crude Oil	TAPS MP 457	Pipeline Leak – intentional sabotage ^{1,3} Unspecified ⁵	11,905 ^{1,3,5}	16,000 ¹
APSC–1 ADEC–2 UNK–3 JPO–5	10-Jun-79	Pipeline	APSC	Atigun Pass	Crude Oil	TAPS MP 166 (N. side of Atigun Pass)	Pipeline Leak – line break ^{1,2,3,5}	1500 ^{1,2,5}	7143 ² 5267 ³
APSC–1 ADEC–2 UNK–3 JPO–5	15-Jun-79	Pipeline	APSC	Little Tonsina	Crude Oil	TAPS MP 734	Pipeline Leak – line break ^{1,2,3,5}	300 ^{2,3,5}	4000 ^{1,2}
APSC–1 ADEC–2 UNK–3 BLM–4 JPO–5 OSIR–6	01-Jan-81	Pipeline	APSC	Check Valve 23	Crude Oil	TAPS MP 114.6 (Check Valve 23)	Pipeline Leak – leaking valve	1000 ²	1500 ^{1,3,4,5} 2000 ⁶ 2381 ²
APSC–1 ADEC–2	20-April-96	Pipeline	APSC	Check Valve 92	Crude Oil	TAPS MP 539.7 (Check Valve 92)	Pipeline Leak – loose fitting	800 ^{1,2}	811 ¹

Source: Hart Crowser (2000)

Notes: 1 APSC (Alyeska Pipeline Service Company), 2 ADEC (Alaska Department of Environmental Conservation), 3 UNK (Unknown) 4 BLM (Bureau of Land Management), 5 JPO (Joint Pipeline Office), and 6 OSIR (Oil Spill Intelligence Report)

Tables A-28 to A-32 Small Spills Greater than or Equal to 1 Gallon and Less than 500 Barrels**A-28. Small Crude-Oil Spills: Estimated Spill Rate for the Alaska North Slope, 1989–1998**

Small Crude-Oil Spills	
Total Volume of Spills	124,506 gallons 2,965 barrels
Total Number of Spills	1,095 spills
Average Spill Size	2.7 barrels
Production (Crude Oil)	5.8 billion barrels
Spill Rate	188 spills/billion barrels of crude-oil produced

Source: USDO, MMS, Alaska OCS Region, 2000. Oil-spill databases are from the ADEC, Anchorage, Juneau, and Fairbanks. Alaska North Slope production data are derived from the TAPS throughput data from Alyeska Pipeline.

A-29. Small Crude-Oil Spills: Assumed Spills Over the Production Life of the Liberty Project

Alternative	Reserves (Bbbl) ¹	Spill Rate (Spills/Bbbl)	Assumed Spill Size (bbl)	Estimated Number of Spills	Estimated Total Spill Volume (bbl)
I	0.120	188	3	23	68
II	0	188	3	0	0
III.A and III.B	0.120	188	3	23	68
IV.A, IV.B and IV.C	0.120	188	3	23	68
V	0.120	188	3	23	68
VI	0.120	188	3	23	68
VII	0.120	188	3	23	68

Source: USDO, MMS, Alaska OCS Region (2000). Notes: ¹ The estimation of oil spills is based on the estimated reserves,

A-30. Small Crude-Oil Spills: Assumed Size Distribution Over the Production Life of the Liberty Project

Size ²	Estimated Number of Spills ¹						
	Alternative I	Alternative II	Alternative III.A & B	Alternative IV.A, B, & C	Alternative IV	Alternative VI	Alternative VI
1 gallon	5	0	5	5	5	5	5
>1 and ≤5 gallons	8	0	8	8	8	8	8
>5 gallons and <1 bbl	4	0	4	4	4	4	4
Total <1 bbl	17	0	17	17	17	17	17
≥1 bbl and ≤bbl 5	5	0	5	5	5	5	5
>5 and ≤25 bbl	1	0	1	1	1	1	1
> 25 and ≤500 bbl	0	0	0	0	0	0	0
Total >1 bbl	6	0	6	6	6	6	6
Total Volume (bbl)	68	0	68	68	68	68	68

Source: USDO, MMS, Alaska OCS Region (2000). Notes: ¹ Estimated number of spills is rounded to the nearest whole number. ² Spill-size distribution is allocated by multiplying the total estimated number of spills by the fraction of spills in that size category from the ADEC database.

A-31. Small Refined-Oil Spills: Estimated Spill Rate for the Alaska North Slope, 1989-1998

Small Refined-Oil Spills	
Total Volume of Spills	76,147 gallons 1,813 barrels
Total Number of Spills	2,585 spills
Average Spill Size	0.7 barrels
Production (Crude Oil)	5.8 billion barrels
Spill Rate	445 spills/billion barrels of crude-oil produced

Source: USDO, MMS, Alaska OCS Region (2000).

A-32. Small Refined-Oil Spills: Assumed Spills Over the Production Life of the Liberty Project

Alternative	Resource Range (Bbbl)	Spill Rate (Spills/Bbbl)	Average Spill Size (bbl)	Estimated Number of Spills ¹	Estimated Total Spill Volume (bbl) ¹
I	0.120	445	0.7 (29 gal)	53	37
II	0	445	0.7 (29 gal)	0	0
III.A and III.B	0.120	445	0.7 (29 gal)	53	37
IV.A, IV.B and IV.C	0.120	445	0.7 (29 gal)	53	37
V	0.120	445	0.7 (29 gal)	53	37
VI	0.120	445	0.7 (29 gal)	53	37
VII	0.120	445	0.7 (29 gal)	53	37

Source: USDO, MMS, Alaska OCS Region (2000). ¹The fractional estimated mean spill number and volume is rounded to the nearest whole number.

Table A-33 Oil-Spill Rates and Spill-Size Categories We Use to Estimate Oil Spills for the Cumulative Analysis

Where Oil Originated	Crude-Oil Spills					
	Alaska North Slope 1985-200		TAPS Pipeline 1985-200		TAPS Tanker 1977-1999	
	Spill Rate (Spills/Bbbl)	Size Category	Spill Rate	Size Category	Spill Rate (Spills/Bbbl)	Size Category
Offshore	0.64	≥500 bbl	0.11	≥500 bbl	0.88 ¹	≥1,000 bbl
Onshore	0.64	≥500 bbl	0.11	≥500 bbl	0.88	≥1,000 bbl

Source: USDOJ, MMS, Alaska OCS Region (2000).

Notes: ¹ Anderson and LaBelle (2001)

Table A-34 Resources and Reserves We Use to Estimate Oil Spills for the Cumulative Analysis

Categories	Subcategories	Reserves and Resources (Bbbl)		
		Total	Onshore	Offshore
Past and Present Production	Past Production	5.822	5.47	0.352
	Present Production	0.185	0.185	- ¹
	<i>Total</i>	6.007	5.655	0.352
Reasonably Foreseeable Future Production	Discovered	1.45	0.5	0.950
	Undiscovered	3.68	2.3	1.38
	<i>Total</i>	5.13	2.8	2.33
Past, Present and Reasonably Foreseeable	<i>Subtotal</i>	11.137	8.455	2.682
	Liberty	0.12	0.0	0.12
	<i>Total</i>	11.257	8.455	2.802

Source: USDOJ, MMS, Alaska OCS Region (2000).

Notes: ¹ Liberty is offshore present production and is considered below

Table A-35 Cumulative Oil-Spill-Occurrence Estimates Greater Than or Equal to 500 Barrels or Greater than or Equal to 1,000 Barrels Resulting from Oil Development over the Assumed 15-20 Year Production Life of the Liberty Project

Category	Crude-Oil Spills					
	Reserves and Resources (Bbbl)	Spill Rate (Spills/Bbbl)	Size Category	Assumed Size	Most Likely Number	Estimated Mean Number
Offshore						
Past, Present and Reasonably Foreseeable	2.68	0.64	≥500 bbl	125–2956	1	1.72
Liberty	0.12	0.64	≥500 bbl	125–2956	0	0.08
Total	2.80	0.64	≥500 bbl	125–2956	1	1.80
Onshore						
Past, Present and Reasonably Foreseeable	8.5	0.64	≥500 bbl	500–925	5	5.41
Liberty	0.12	0.11	≥500 bbl	720–1,142	0	0.01
Total	8.62	0.11	≥500 bbl	500–1,142	5	5.42
TAPS Pipeline						
Past, Present and Reasonably Foreseeable	11.14	0.11	≥500 bbl	500–999	1	1.23
Liberty	0.12	0.11	≥500 bbl	500–999	0	0.01
Total	11.26	0.11	≥500 bbl	500–999	1	1.24
TAPS Tanker						
Past, Present and Reasonably Foreseeable	11.14	0.88	≥1,000 bbl	Table A-37	9	9.8
Liberty	0.12	0.88	≥1,000 bbl	Table A-37	0	0.11
Total	11.26	0.88	≥1,000 bbl	Table A-37	9	9.91

Source: USDOJ, MMS, Alaska OCS Region (2001). Notes: The Alaska Dept. of Environmental Conservation database has no significant crude oil spills on the North Slope resulting from well blowouts and no facility or onshore pipeline spills greater than 1,000 barrels for the years 1985-2000.

Table A-36 Trans-Alaska Pipeline System Tanker Spills Greater than or Equal to 1,000 Barrels: 1977 through 1998

Date	Vessel	Location	Destination	Amount
8/29/78	Overseas Joyce	Balboa Channel	Perth Amboy, New Jersey	1,816
6/7/80	Texaco Connecticut	Panama Canal Zone	Port Neches, Texas	4,047
12/12/81	Stuyvesant	Gulf of Tehuantepec	Panama	3,600
12/21/85	ARCO Anchorage	Puget Sound	Cherry Point, Washington	5,690
1/9/87	Stuyvesant	Gulf of Alaska, British Columbia	Puerto Armuelles, Panama	15,000
7/2/87	Glacier Bay	Cook Inlet, Alaska	Nikiski, Alaska	4,900
10/4/87	Stuyvesant	Gulf of Alaska, British Columbia	Puerto Armuelles, Panama	14,286
1/3/89	Thompson Pass	Port of Valdez	Panama	1,700
3/24/89	Exxon Valdez	Prince William Sound, Alaska	Long Beach, California	240,500
2/7/90	American Trader	Huntington Beach, California	Long Beach, California	9,929
2/22/91	Exxon San Francisco	Fidalgo Bay, Washington	Anacortes, Washington	5,000

Source: Anderson and Lear (1994) and Anderson (2000b)

Table A-37 Sizes of Tanker Spills We Assume from the Trans-Alaska Pipeline System in the Cumulative Analysis

Size Category	Number	Average Size	Total Volume
≤6,000	6	4,000	24,000
>6,001–≤15,000	2	13,000	26,000
>200,000	1	250,000	250,000
Total	9	—	294,000

Source: USDOJ, MMS, Alaska OCS Region (2000).

Notes: The distribution of the number of spills is based on the percentage of spills in a size category from actual Trans Alaska Pipeline System tanker spills listed in Table A-36. Table 36 shows that sixty six percent are ≤6,000, seventeen percent are >6,001–≤15,000 and 8 percent are ≥ 200,000.

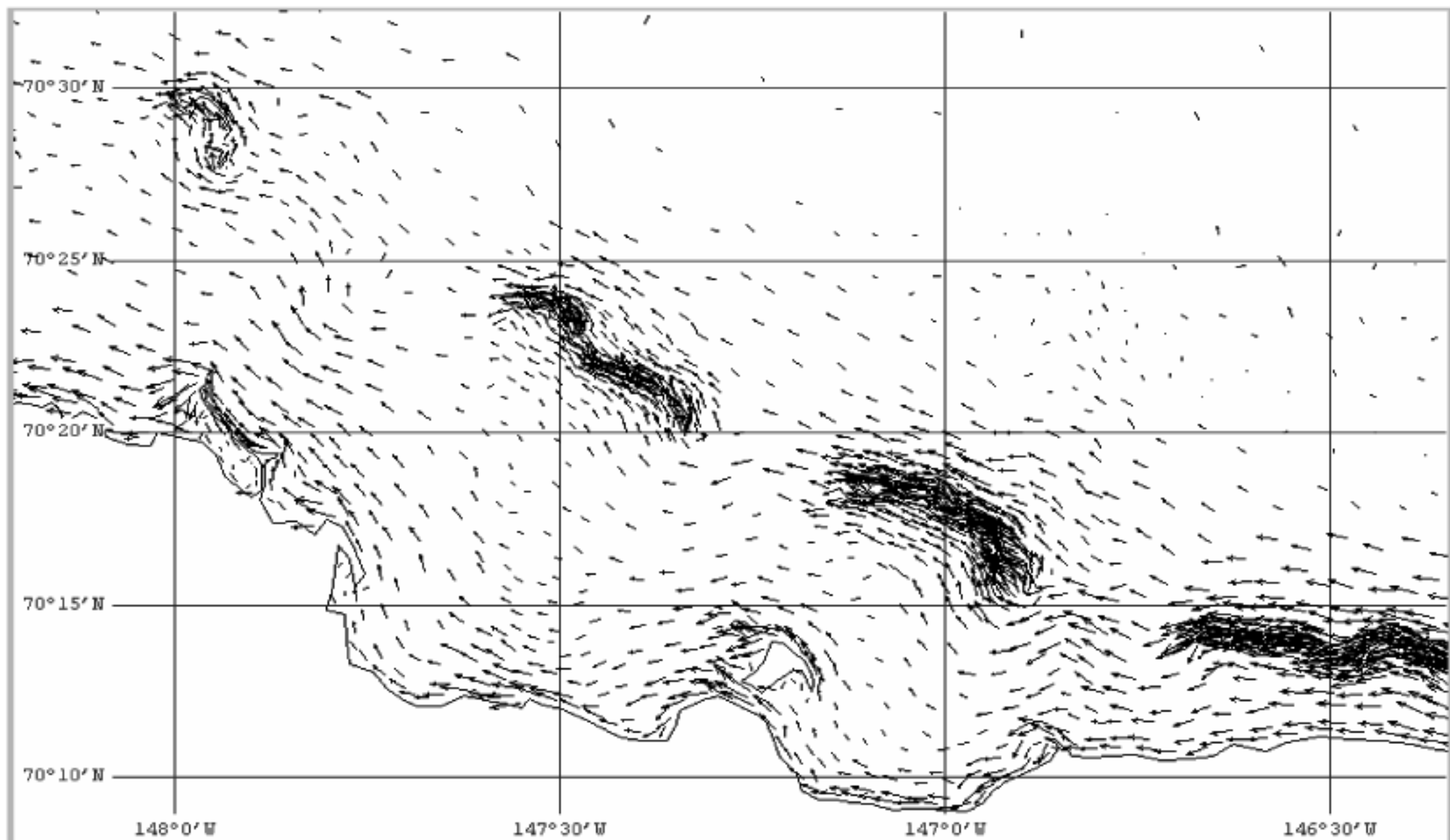

Figure A-1 Nearshore Surface Currents Simulated by the NOAA Model for a Wind from the East at 10 Meters Per Second.

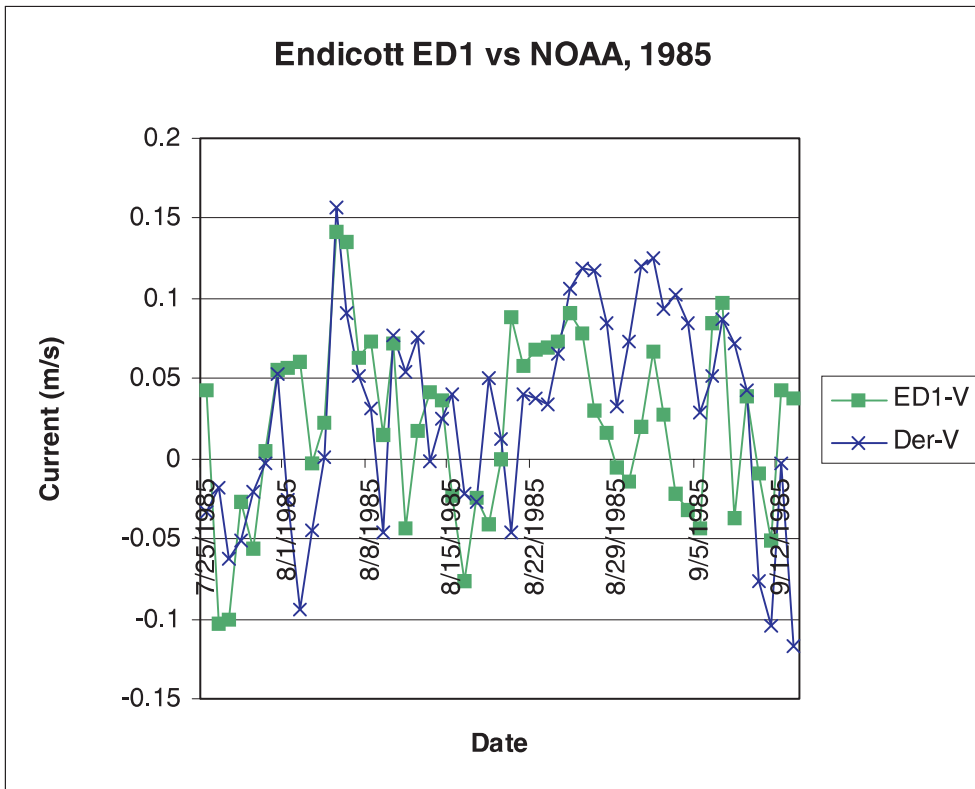
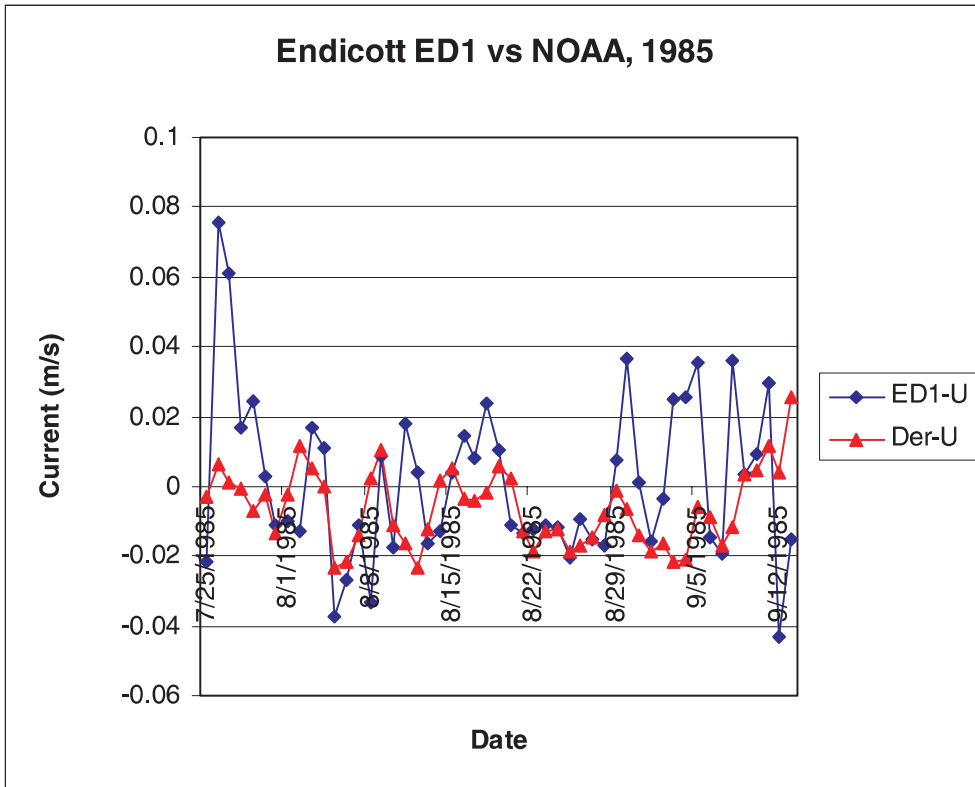

Figure A.2. Example Time Series from 1985. It shows the current flow at Endicott Station ED1 from the U (east-west) and V (north-south) components, plotted on the same axis with the current derived from the NOAA model for U and V (Der-U and Der-V).

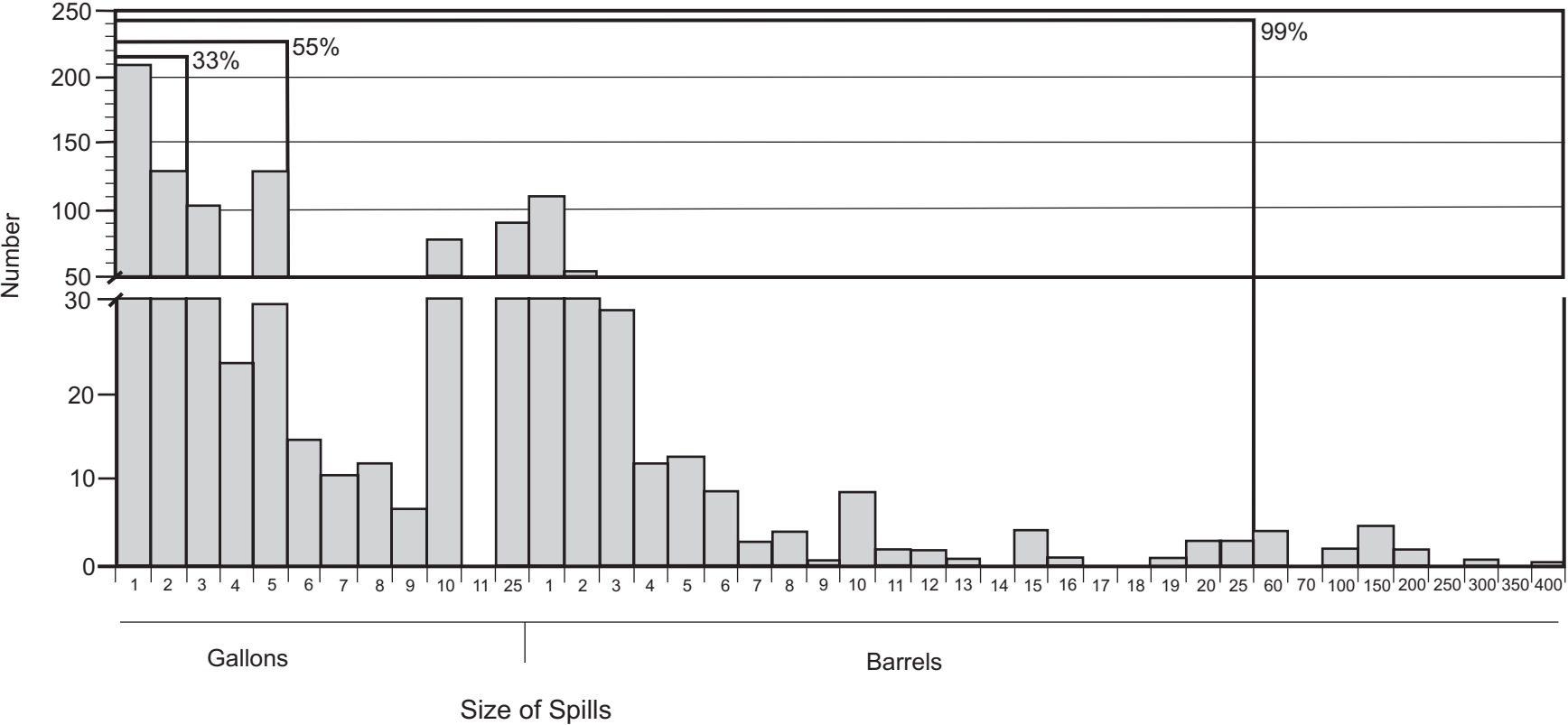
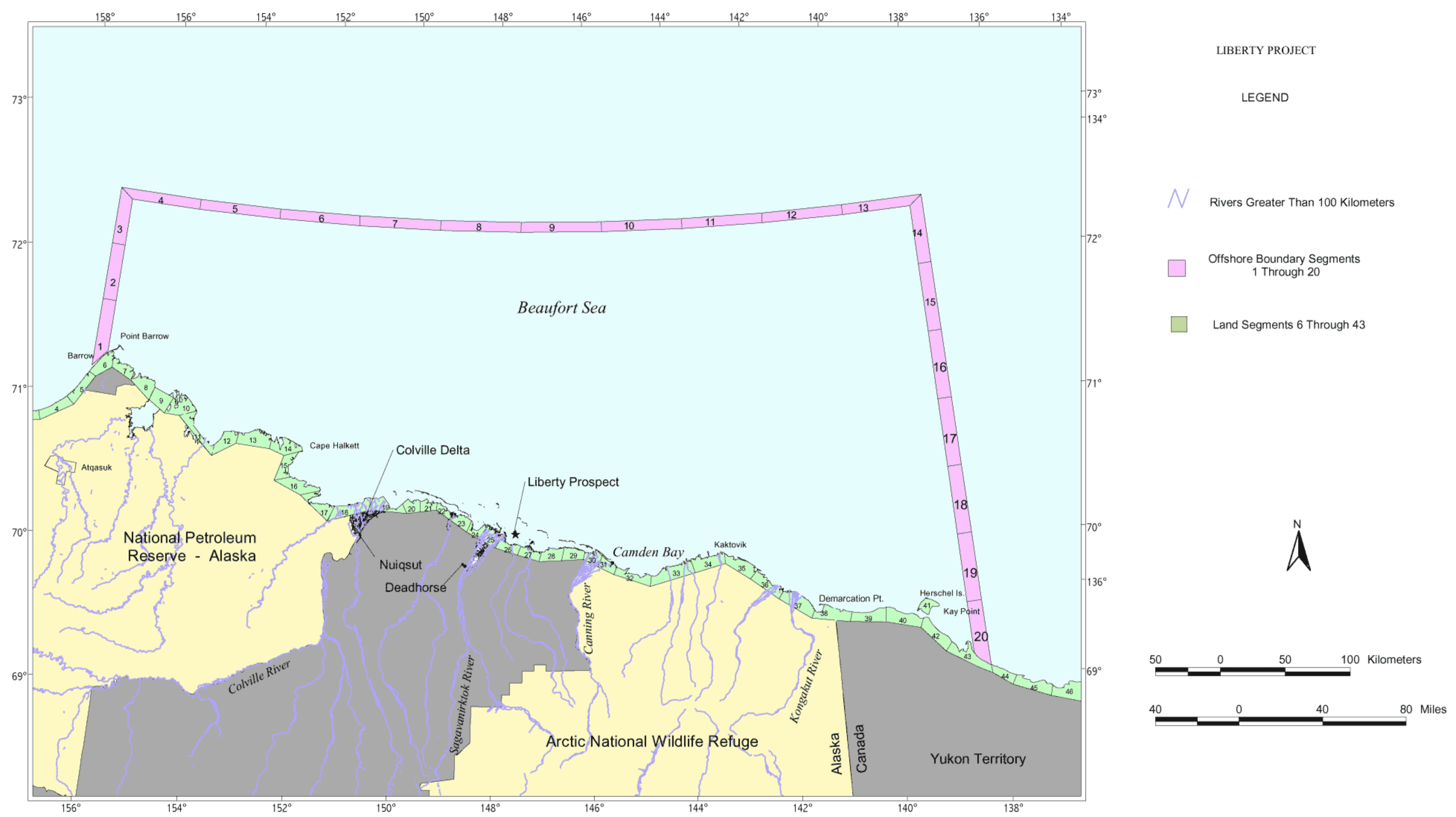

Figure A-3. Alaska North Slope Crude Oil Spill Size Distribution of Spills Less than 500 Barrels and Percent of Spills Less than 2 Gallons, 5 gallons and 25 Barrels for the Period 1989-1998.



Map A-1 Offshore Boundary Segments and Land Segments

LIBERTY PROJECT

LEGEND

Months When Environmental Resource Areas are Vulnerable to Oil Spills

Environmental Resource Areas

-  April-May
-  August-October
-  January-December
-  May-October

 Beaufort Coast with Barrier Islands

 Existing Pipelines

 Land Segments

 North Slope Rivers Greater than 100 Km

 Liberty Prospect



20 0 20 40 Kilometers

10 0 10 20 Miles

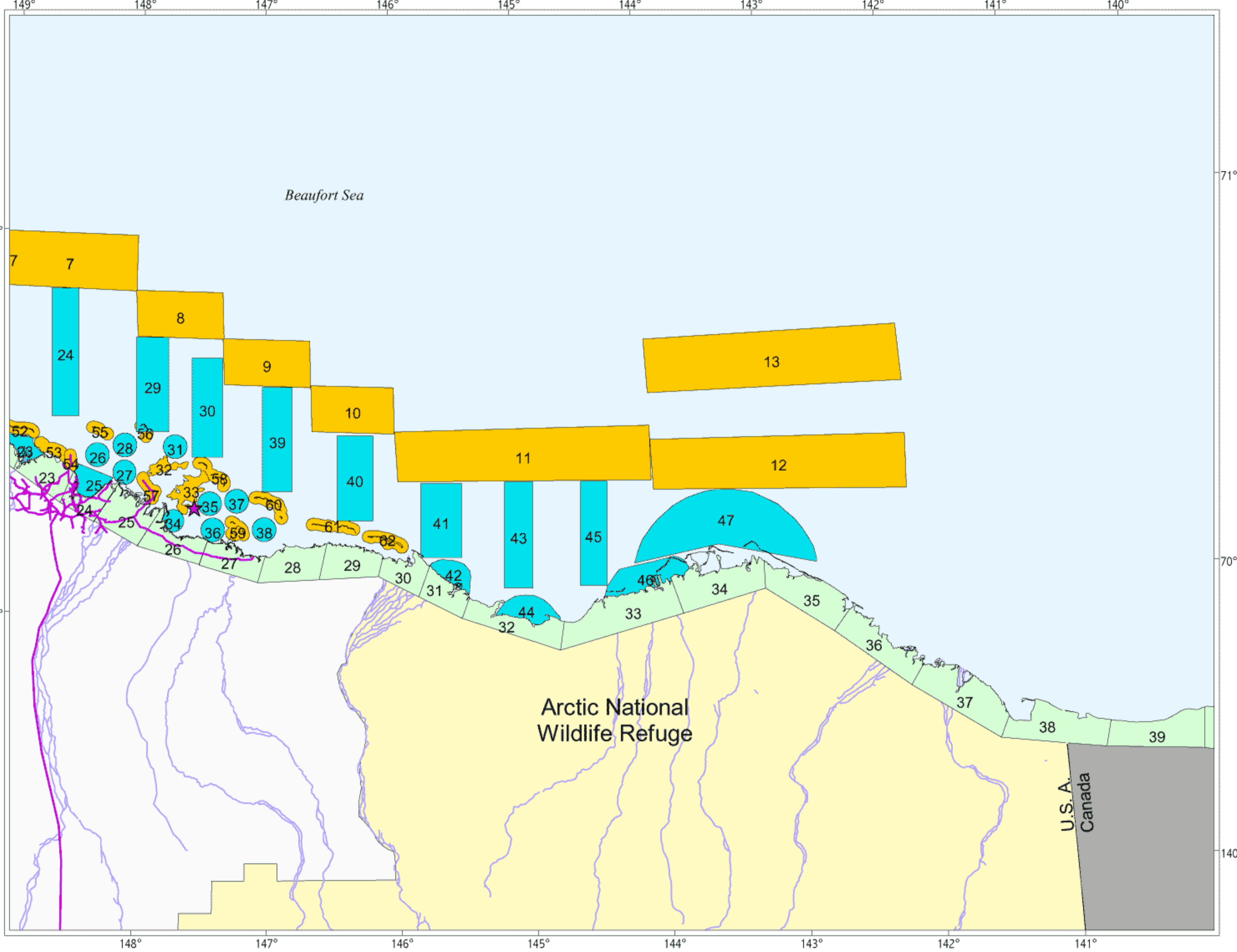

Map A-2 Location and Seasonal Vulnerability of the Environmental Resource Areas and Ice and Sea Segments Used in the Liberty Oil-Spill-Trajectory Analysis; Eastern Half

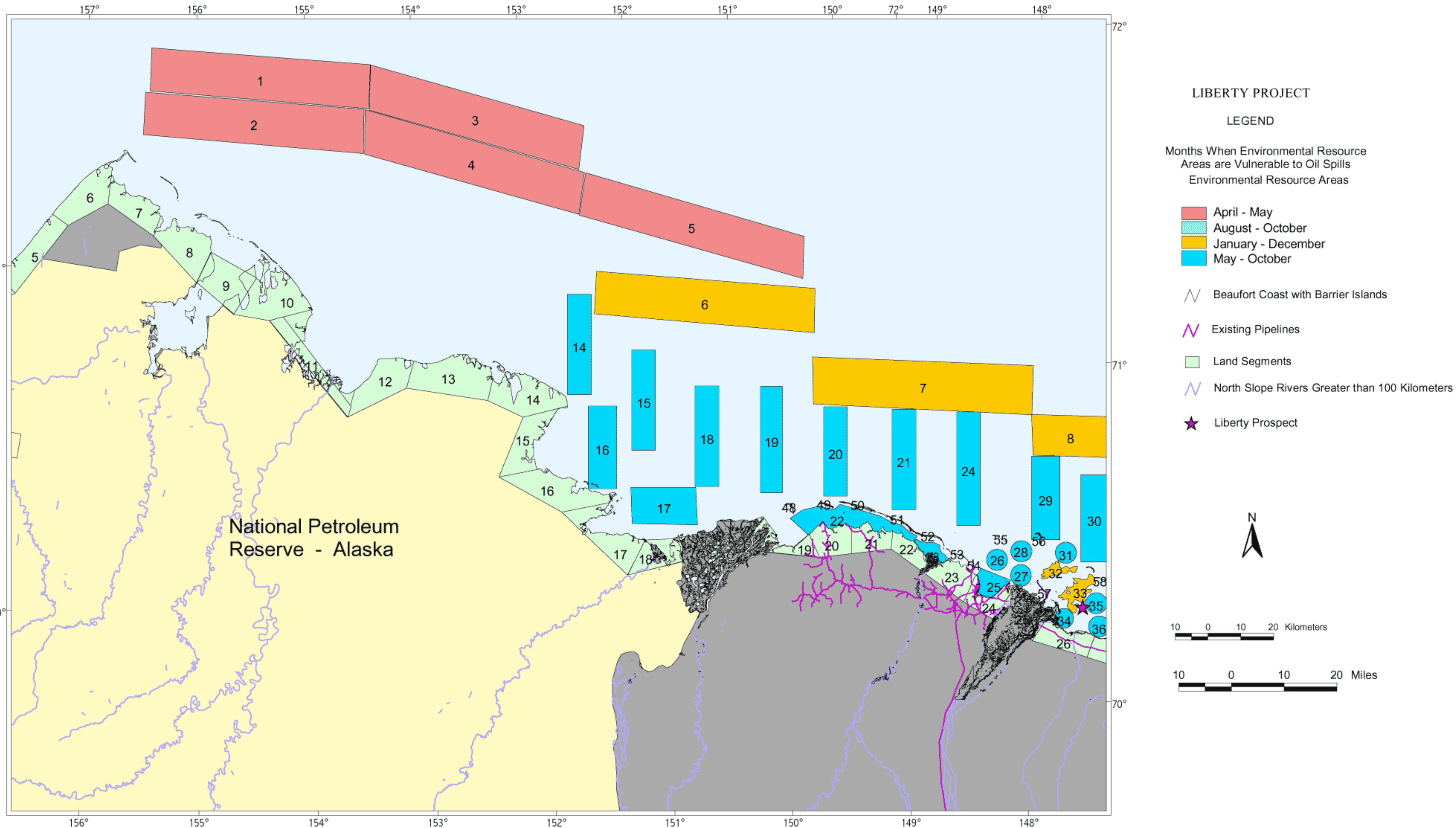

Map A-3 Location and Seasonal Vulnerability of the Environmental Resource Areas and Ice and Sea Segments Used in the Liberty Oil-Spill-Trajectory Analysis; Western Half

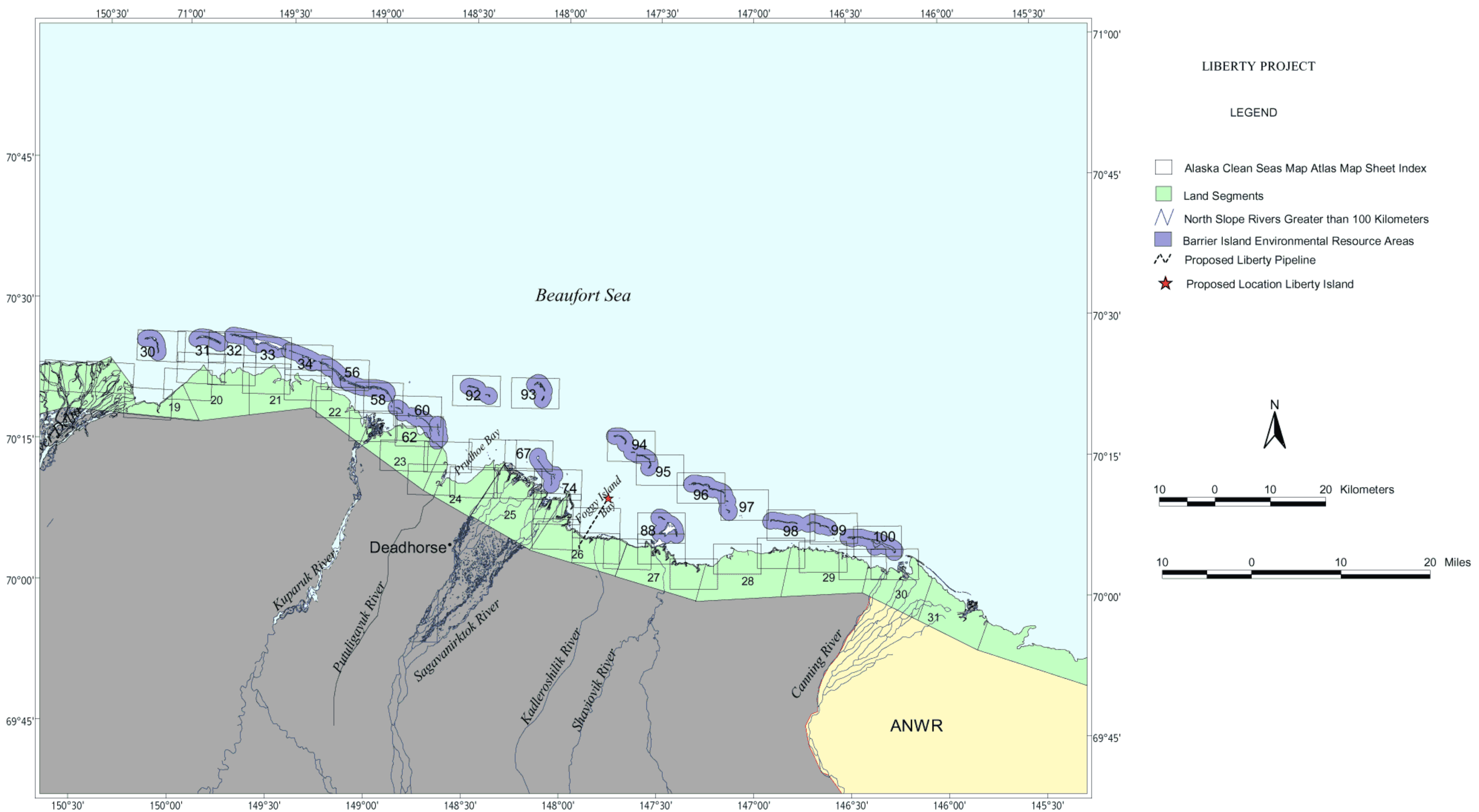

Map A-4 Barrier Island Environmental Resource Areas Correlated to Alaska Clean Seas Map Atlas Map Sheet Indices

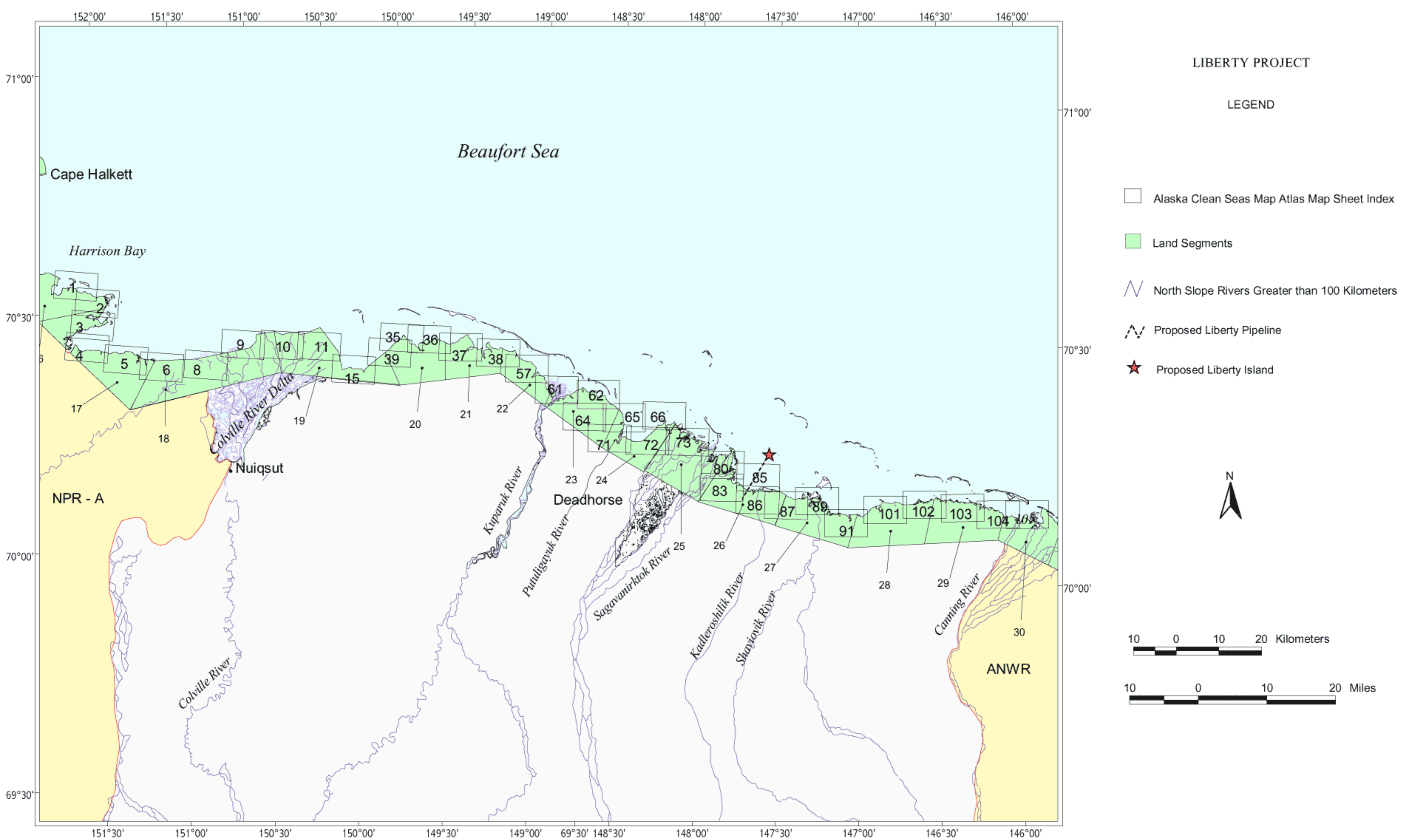

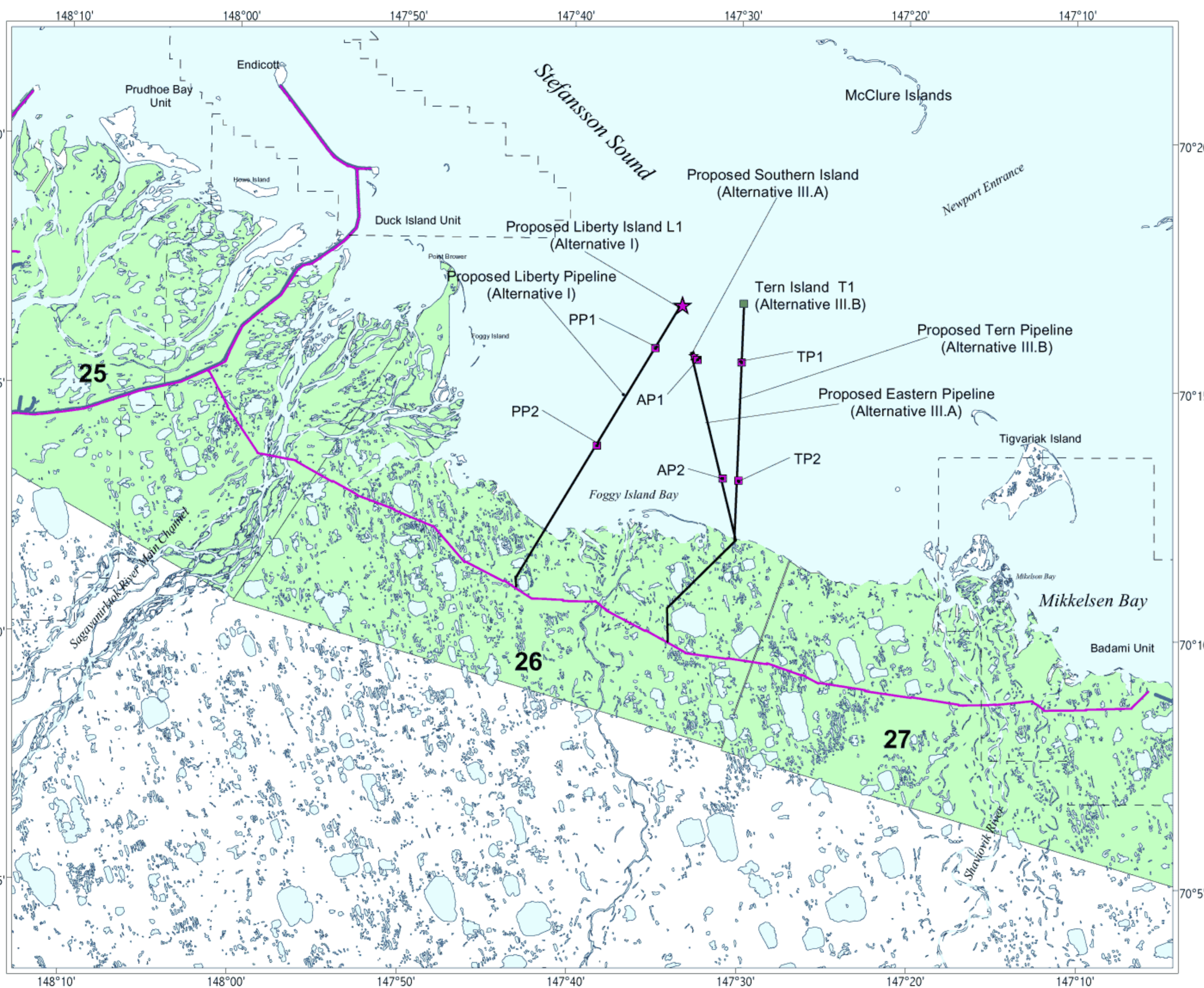

Map A-5 Land Segments Correlated to Alaska Clean Seas Map Atlas Map Sheet Indexes

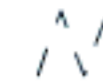

LIBERTY PROJECT

Legend

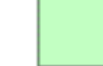
-  Unit Boundaries
-  Hypothetical Spill Sites
-  Primary Roads
-  Existing Pipelines
-  Land Segments

- L1 - Proposed Liberty Island
- PP1 and PP2 - Proposed Liberty Pipeline
- AP1 and AP2 - Proposed Eastern Pipeline
- T1 - Tern Island
- TP1 and TP2 - Proposed Tern Pipeline

Map A-6 Spill sites used in the Oil-Spill-Trajectory Analysis

APPENDIX B

OVERVIEW OF LAWS, REGULATIONS, AND RULES

This appendix was published as part of the Liberty Development and Production Plan (DPP) Draft Environmental Impact Statement (EIS) and was not revised for the Final EIS. The reader is referred to this appendix in the Draft EIS. This appendix is also available on the CD-ROM (MMS 2002-019 CD) and on the Internet (<http://www.mms.gov/alaska/cproject/liberty>).

Appendix B

Overview of Laws, Regulations, and Rules That Relate to the Proposed Activities Described in the Liberty Development Project, Development and Production Plan

This appendix references only those portions of Federal public laws enacted by Congress related directly or indirectly to the Minerals Management Service's (MMS) regulatory responsibilities for mineral leasing, exploration, and development and production activities on leases located in the submerged lands of the outer continental shelf (OCS). It also includes responsibilities and jurisdictions of other Federal agencies and departments that also are involved in the regulatory process of oil and gas operations on the OCS. This is not intended to be a comprehensive summary of all laws associated with proposed exploration and development activities that significantly might affect the OCS. Explanations are merely to acquaint the reader with the law and are not meant as legal interpretations. Readers should consult the entire text of the law for additional requirements and information.

A. OVERVIEW

1. The MMS is the Federal Agency Responsible for Managing Mineral Resources on the OCS

Under the OCS Lands Act (OCSLA; see Part C of this appendix), as amended (43 U.S.C. 1331 et seq.), and 30 C.F.R. 250, the MMS, through delegation of authority as authorized by the Secretary of the Interior, has jurisdiction over OCS lease development projects, including construction, drilling, facilities, and operations. Once a lease is "awarded," the MMS's Regional Supervisor, Field Operations (RSFO) is responsible for approving, supervising, and regulating all operations that are conducted on the leased area. Before conducting operations on a lease, except for certain preliminary activities, a lessee must

submit an exploration or development and production plan to the MMS for approval, an Oil Spill Contingency Plan, and an Application for Permit to Drill. A plan is processed according to the regulations found under 30 C.F.R. 250 and subject to the regulations that govern Federal Coastal Zone Management consistency procedures (15 C.F.R. 930). The MMS Environmental Studies Program monitors changes in human, marine, and coastal environments during and after oil exploration or development and production, as authorized in Section 20(b) of the OCSLA, as amended (43 U.S.C. § 1346(b)).

The law requires the MMS to consult and coordinate with other Federal agencies (such as the Office of Ocean and Coastal Resource Management, Fish and Wildlife Service, National Marine Fisheries Service, U.S. Environmental Protection Agency, National Park Service, the Corps of Engineers, and U.S. Coast Guard), the State of Alaska, and local government agencies, as appropriate, which have jurisdiction by law, special expertise, or with direct or indirect authority to develop and enforce environmental standards to ensure that the activities to be performed as described in a proposed plan comply with all applicable Federal statutory laws. The MMS has entered into formal agreements with other Federal departments or agencies and with the State of Alaska to clarify or, when appropriate, delegate certain authority with respect to jurisdictional responsibilities for activities proposed on the OCS. The MMS also must provide an opportunity for the public to comment on a proposed plan. The regulations direct Federal agencies that have made a decision to prepare an environmental impact statement (EIS) to conduct a public scoping process. The key purpose of the scoping process is to determine the scope of the EIS and the range of actions, alternatives, and impacts to be considered in the EIS as they relate to actions in a proposed plan. Scoping should do the following:

- identify public and agency issues with actions proposed in a plan;
- identify and define the significant environmental issues and alternatives to be examined in an EIS, including the elimination of nonsignificant issues;
- identify related issues that originate from separate legislation, regulation, or Executive Orders (for example, historic preservation or endangered species issues); and
- identify State and local agency requirements that must be addressed.

It should be emphasized that the reason scoping meetings are held is to receive valuable public input into the EIS process to ensure that the EIS will be thorough and will address all pertinent issues to the fullest extent possible which will play a major role in the MMS's decisionmaking process. The end result of the scoping process will be a more informed public cognizant of all facets of a proposed plan's actions.

2. The Formal Review Process

After an extensive initial review of BP Exploration (Alaska), Inc.'s (BPXA's) application for approval on its proposed Liberty Development Project, Development And Production Plan (the Plan), in an area located on Lease Number OCS-Y-01650, the MMS deemed the Plan as officially submitted. The formal review process on the Plan has commenced, and the MMS has begun an extensive technical, engineering, and environmental analysis of BPXA's Plan (and supporting information) to determine if the Plan can be approved, disapproved, or modified and resubmitted for approval by the RSFO. To ensure conformance with the OCSLA, other laws, applicable regulations, and lease provisions, and to enable MMS to carry out its functions and responsibilities, the MMS will review the Plan for compliance as authorized in 30 C.F.R. 250.204. During this review process, the MMS will examine such details as structural specifications, safety systems, installation verification, drilling procedures, facility and pipeline specifications, and environmental protection. The regulations require that a proposed plan describe the area's location, size, design, and sequential schedules for beginning and ending all activities to be performed that are directly related to the development and production plan. Additionally, descriptions of any drilling vessels, platforms, pipelines, or other facilities and operations that are known or directly related to the proposal must be provided, including plans for important safety, pollution prevention, and environmental monitoring features and other relevant information about the plan's facilities and operations. Required supporting environmental information, such as geological and geophysical data and information, shallow-hazards surveys and reports, classification and information concerning the presence and proposed

precautionary measures for hydrogen sulfide, archaeological resource surveys and reports, biological survey reports, or other environmental data or information determined necessary, must accompany the proposed plan, including new or unusual technology to be used. The MMS must receive written notification indicating which portions, if any, of a plan's supporting information is believed to be exempt from disclosure under the Freedom of Information Act (5 U.S.C. 552) and the implementing regulations (43 C.F.R. 2).

BPXA's proposed Plan is being reviewed and processed according to the regulations found in 30 C.F.R. 250. The Plan also is subject to the State of Alaska's concurrence or presumed concurrence with coastal zone consistency certification, as provided in 25 C.F.R. 930. The MMS may not issue a permit for the proposed Plan's development and production activities unless the State of Alaska concurs with the certification that BPXA's Plan is consistent with the State's Coastal Zone Management Program or the Secretary of Commerce makes certain findings afterwards and overrides the State's objections under the Coastal Zone Management Program.

As part of the review process, the MMS must consider the economic, social, and environmental values of the renewable and nonrenewable resources contained in the OCS and examine what the potential effect of oil and gas exploration or development and production activities would or might have on the marine, coastal, and human environments.

3. Preparing the EIS

The National Environmental Policy Act of 1969 (NEPA), as amended (42 U.S.C. § 4321 et seq.), mandates that Federal agencies consider the environmental effects of major Federal actions. The primary purpose of an EIS is to serve as an action-forcing device to ensure that the policies and goals defined in the NEPA are incorporated into the ongoing programs and actions of the Federal Government. Before decisions are made and before actions are taken, NEPA procedures require Federal agencies with NEPA-related functions to gather information about the environmental consequences of proposed actions and consider the environmental impacts of those actions. By doing so, agencies will be better able to prepare the appropriate environmental documentation on actions to support the agency's planning and environmental decisionmaking. Also, NEPA can be used by Federal officials in conjunction with other relevant material to plan actions and make decisions. Provisions in the NEPA require agencies to focus on significant environmental issues and provide full and fair discussion of significant environmental impacts and range of reasonable alternatives that would avoid or lessen adverse impacts or enhance the quality of the human environment.

This includes alternatives and appropriate mitigation measures not already included in a proposed action.

Upon preliminary review, the MMS evaluated the environmental impact of the activities described in BPXA's Plan and determined those development and production activities to be "a major federal action that may significantly affect the quality of the human environment pursuant to the NEPA." The regulations at 40 C.F.R. 1501 require the MMS to use the NEPA process to identify and assess a range of alternatives reasonable to the proposed Plan's development and production activities that would avoid or minimize any possible adverse effects of these actions upon the quality of the human environment. To adequately fulfill and satisfy the requirements to "the fullest extent possible" under the NEPA, the MMS is preparing the appropriate environmental documentation. The MMS will make every effort to disclose and discuss within the EIS all major points of view on the environmental effects of the alternatives, including the proposed action.

This EIS is a specific project NEPA document that identifies, considers, and assesses to the fullest extent possible the appropriate range of resources and ecosystem components in a defined geographic area affected by ongoing and anticipated future activities as proposed in the Liberty Plan. The EIS identifies and evaluates an appropriate range of alternatives to BPXA's proposed project and what potential effects the alternatives may have on the quality of the human environment and on the Liberty Plan. The phrase "range of alternatives" refers to the alternatives discussed in the EIS and includes all reasonable alternatives that must be rigorously explored and objectively evaluated, as well as those alternatives that are eliminated from detailed study, with a brief discussion of the reasons for eliminating them.

Public and agency involvement and participation associated with NEPA documentation are ongoing, including consultation and coordination with the State of Alaska regarding coastal zone consistency determinations and the MMS's responsibility to the Oil Pollution Act of 1990 (OPA) (U.S.C. 2701, et. seq.). The ultimate goal of this combined agency effort is to produce an EIS that, in addition to fulfilling the basic intent of NEPA, encompasses "to the fullest extent possible" all the environmental and public involvement required by State and Federal laws, Executive Orders, and the administrative policies of the agencies involved. Throughout the review process of BPXA's Plan, the MMS will continually involve the State of Alaska, schedule public scoping meetings, and make presentations to local citizen groups, particularly in those communities closest to the area affected by the activities that are described in the proposed Plan.

4. Approval of the Plan

Conditions of plan approval are mechanisms determined by the MMS to control or mitigate potential adverse environmental impacts or safety problems associated with the Liberty Plan. Environmental reviews and analyses developed through the NEPA process may further identify the need for additional protective measures specific to the Liberty Plan. The RSFO may require additional mitigating measures and impose necessary project-specific operational stipulations.

After a plan's approval, specific applications must be submitted to the MMS for permits or other approvals. These additional applications could include those for wells, pipelines, platforms, and other related activities as described in the Plan. The information in the EIS will be used when approving permits or making other action decisions. Conditions necessary to providing appropriate environmental protection can be applied to any OCS plans, permits, grants, or other approvals.

A list of all permits, licenses, and other entitlements from Federal, State, and local agencies related to the Liberty Plan is found in Table B-1.

B. MITIGATING MEASURES THAT APPLY TO THE LIBERTY DEVELOPMENT AND PRODUCTION PLAN

In each OCS planning area, oil and gas exploration and development activities have the potential for causing adverse environmental impacts.

Many measures have been implemented by the MMS to "mitigate" or prevent and lessen possible impacts on environmental resources from both OCS and non-OCS activities. Mitigating measures are protective measures designed to prevent adverse impacts and to lessen and mitigate unavoidable impacts. The MMS develops and administers these requirements, which are part of the lease-term conditions at lease issuance.

In order to mitigate adverse environmental impacts for actions associated with a specific project (i.e., proposed plans for exploration, development, production, and site-clearance activities in an area located on an OCS lease block), additional mitigation requirements may be necessary. Conditions of plan approval are mechanisms determined by MMS to control or mitigate potential environmental or safety problems that are associated with a specific proposal. Special stipulations that limit operations are in addition to the lease-term stipulations. During the life of the action, these protective measures are specific to the individual activities proposed in a plan and are imposed

following environmental reviews (according to the NEPA) of the OCS lease block location and potential resources.

1. Lease-Term Stipulations

Some of these protective measures are developed and applied to specific blocks in a planning area before leasing a block and are based on the following:

- existing policies and laws;
- knowledge of the resources present in the planning area where the block is being offered for lease by the MMS; and
- current industry practices.

If a block is leased as a result of a lease sale, these protective measures are identified as lease-term stipulations and are attached to and become part of the lease and its conditions. These stipulations are designed to protect potentially sensitive resources in the affected block and to reduce possible multiple-use conflicts and are the requirements that the lessee must meet to mitigate adverse impacts. They also may be considered to apply to all activities that occur on the leased area throughout the life of the lease.

As the lead permitting agency with jurisdiction over the proposed activities to develop the Liberty Project in the Alaskan Beaufort Sea, the MMS Alaska OCS Region must consider the full scope of the development activity described in the proposed BPXA Plan. The proposed Plan affects a single Federal oil and gas lease—Lease No. OCS Y-01650—(issued as a result of Sale 144). The following lease-term stipulations apply to Lease No. OCS-Y-01650 and, as such, are considered as part of the Liberty Development Project, Development and Production Plan Proposal.

a. Stipulation No. 1, Protection of Biological Resources

If biological populations or habitats that may require additional protection are identified in the lease area by the Regional Supervisor, Field Operations (RS/FO), the RS/FO may require the lessee to conduct biological surveys to determine the extent and composition of such biological populations or habitats. The RS/FO shall give written notification to the lessee of the RS/FO's decision to require such surveys.

Based on any surveys that the RS/FO may require of the lessee or on other information available to the RS/FO on special biological resources, the RS/FO may require the lessee to:

- Relocate the site of operations;
- Establish to the satisfaction of the RS/FO, on the basis of a site-specific survey, either that such operations

would not have a significant adverse effect upon the resource identified or that a special biological resource does not exist;

- Operate during those periods of time, as established by the RS/FO, that do not adversely affect the biological resources; and/or
- Modify operations to ensure that significant biological populations or habitats deserving protection are not adversely affected.

If any area of biological significance should be discovered during the conduct of any operations on the lease, the lessee shall immediately report such findings to the RS/FO and make every reasonable effort to preserve and protect the biological resource from damage until the RS/FO has given the lessee direction with respect to its protection.

The lessee shall submit all data obtained in the course of biological surveys to the RS/FO with the locational information for drilling or other activity. The lessee may take no action that might affect the biological populations or habitats surveyed until the RS/FO provides written directions to the lessee with regard to permissible actions. The RS/FO will utilize the best available information as determined in consultation with the Arctic Biological Task Force.

b. Stipulation No. 2, Orientation Program

The lessee shall include in any exploration or development and production plans submitted under 30 CFR 250.33 and 250.34 a proposed orientation program for all personnel involved in exploration or development and production activities (including personnel of the lessee's agents, contractors, and subcontractors) for review and approval by the Regional Supervisor, Field Operations. The program shall be designed in sufficient detail to inform individuals working on the project of specific types of environmental, social, and cultural concerns that relate to the sale and adjacent areas. The program shall address the importance of not disturbing archaeological and biological resources and habitats, including endangered species, fisheries, bird colonies, and marine mammals and provide guidance on how to avoid disturbance. This guidance will include the production and distribution of information cards on endangered and/or threatened species in the sale area. The program shall be designed to increase the sensitivity and understanding of personnel to community values, customs, and lifestyles in areas in which such personnel will be operating. The orientation program shall also include information concerning avoidance of conflicts with subsistence, commercial fishing activities, and pertinent mitigation.

The program shall be attended at least once a year by all personnel involved in onsite exploration or development and production activities (including personnel of the lessee's agents, contractors, and subcontractors) and all supervisory

and managerial personnel involved in lease activities of the lessee and its agents, contractors, and subcontractors.

The lessee shall maintain a record of all personnel who attend the program onsite for so long as the site is active, not to exceed 5 years. This record shall include the name and date(s) of attendance of each attendee.

c. Stipulation No. 3, Transportation of Hydrocarbons

Pipelines will be required: (a) if pipeline rights-of-way can be determined and obtained; (b) if laying such pipelines is technologically feasible and environmentally preferable; and (c) if, in the opinion of the lessor, pipelines can be laid without net social loss, taking into account any incremental costs of pipelines over alternative methods of transportation and any incremental benefits in the form of increased environmental protection or reduced multiple-use conflicts. The lessor specifically reserves the right to require that any pipeline used for transporting production to shore be placed in certain designated management areas. In selecting the means of transportation, consideration will be given to recommendations of any advisory groups and Federal, State, and local governments and industry.

Following the development of sufficient pipeline capacity, no crude oil production will be transported by surface vessel from offshore production sites, except in the case of an emergency. Determinations as to emergency conditions and appropriate responses to these conditions will be made by the Regional Supervisor, Field Operations.

d. Stipulation No. 4, Industry Site-Specific Bowhead Whale-Monitoring Program

Lessees proposing to conduct exploratory drilling operations, including seismic surveys, during the bowhead whale migration will be required to conduct a site-specific monitoring program approved by the Regional Supervisor, Field Operations (RS/FO); unless, based on the size, timing, duration, and scope of the proposed operations, the RS/FO, in consultation with the North Slope Borough (NSB) and the Alaska Eskimo Whaling Commission (AEWC), determine that a monitoring program is not necessary. The RS/FO will provide the NSB, AEWC, and the State of Alaska a minimum of 30 but no longer than 60 calendar days to review and comment on a proposed monitoring program prior to approval. The monitoring program must be approved each year before exploratory drilling operations can be commenced.

The monitoring program will be designed to assess when bowhead whales are present in the vicinity of lease operations and the extent of behavioral effects on bowhead whales due to these operations. In designing the program,

lessees must consider the potential scope and extent of effects that the type of operation could have on bowhead whales. Scientific studies and individual experiences relayed by subsistence hunters indicate that, depending on the type of operations, individual whales may demonstrate avoidance behavior at distances of up to 24 km. The program must also provide for the following:

- Recording and reporting information on sighting of other marine mammals and the extent of behavioral effects due to operations,
- Inviting an AEWC or NSB representative to participate in the monitoring program as an observer,
- Coordinating the monitoring logistics beforehand with the MMS Bowhead Whale Aerial Survey Project (BWASP),
- Submitting daily monitoring results to the MMS BWASP,
- Submitting a draft report on the results of the monitoring program to the RS/FO within 60 days following the completion of the operation. The RS/FO will distribute this draft report to the AEWC, the NSB, the State of Alaska, and the National Marine Fisheries Service (NMFS).
- Submitting a final report on the results of the monitoring program to the RS/FO. The final report will include a discussion of the results of the peer review of the draft report. The RS/FO will distribute this report to the AEWC, the NSB, the State of Alaska, and the NMFS.

Lessees will be required to fund an independent peer review of a proposed monitoring plan and the draft report on the results of the monitoring program. This peer review will consist of independent reviewers who have knowledge and experience in statistics, monitoring marine mammal behavior, the type and extent of the proposed operations, and an awareness of traditional knowledge. The peer reviewers will be selected by the RS/FO from experts recommended by the NSB, the AEWC, industry, NMFS, and MMS. The results of these peer reviews will be provided to the RS/FO for consideration in final approval of the monitoring program and the final report, with copies to the NSB, AEWC, and the State of Alaska.

In the event the lessee is seeking a Letter of Authorization (LOA) or Incidental Harassment Authorization (IHA) for incidental take from the NMFS, the monitoring program and review process required under the LOA or IHA may satisfy the requirements of this stipulation. Lessees must advise the RS/FO when it is seeking an LOA or IHA in lieu of meeting the requirements of this stipulation and provide the RS/FO with copies of all pertinent submittals and resulting correspondence. The RS/FO will coordinate with the NMFS and advise the lessee if the LOA or IHA will meet these requirements.

This stipulation applies to the blocks and time periods shown in Table B-2 and will remain in effect until

termination or modification by the Department of the Interior, after consultation with the NMFS and the NSB.

e. Stipulation No. 5, Subsistence Whaling and Other Subsistence Activities

Exploration and development and production operations shall be conducted in a manner that prevents unreasonable conflicts between the oil and gas industry and subsistence activities (including, but not limited to, bowhead whale subsistence hunting).

Prior to submitting an exploration plan or development and production plan (including associated oil-spill contingency plans) to the MMS for activities proposed during the bowhead whale migration period, the lessee shall consult with the potentially affected subsistence communities, Barrow, Kaktovik, or Nuiqsut, the North Slope Borough (NSB), and the Alaska Eskimo Whaling Commission (AEWC) to discuss potential conflicts with the siting, timing, and methods of proposed operations and safeguards or mitigating measures, which could be implemented by the operator to prevent unreasonable conflicts. Through this consultation, the lessee shall make every reasonable effort to assure that exploration, development, and production activities are compatible with whaling and other subsistence hunting activities and will not result in unreasonable interference with subsistence harvests.

A discussion of resolutions reached during this consultation process and plans for continued consultation shall be included in the exploration plan or the development and production plan. In particular, the lessee shall show in the plan how activities will be scheduled and located to prevent unreasonable conflicts with subsistence activities. Lessees shall also include a discussion of multiple or simultaneous operations, such as ice management and seismic activities, that can be expected to occur during operations in order to more accurately assess the potential for any cumulative affects. Communities, individuals, and other entities who were involved in the consultation shall be identified in the plan. The RS/FO shall send a copy of the exploration plan or development and production plan (including associated oil-spill contingency plans) to the potentially affected communities, and the AEWC at the time they are submitted to the MMS to allow concurrent review and comment as part of the plan approval process.

In the event no agreement is reached between the parties, the lessee, the AEWC, the NSB, the National Marine Fisheries Service (NMFS), or any of the subsistence communities that could potentially be affected by the proposed activity may request that the RS/FO assemble a group consisting of representatives from the subsistence communities, AEWC, NSB, NMFS, and the lessee(s) to specifically address the conflict and attempt to resolve the issues before making a final determination on the adequacy of the measures taken to prevent unreasonable conflicts with

subsistence harvests. Upon request, the RS/FO will assemble this group before making a final determination on the adequacy of the measures taken to prevent unreasonable conflicts with subsistence harvests.

The lessee shall notify the RS/FO of all concerns expressed by subsistence hunters during operations and of steps taken to address such concerns. Lease-related use will be restricted when the RS/FO determines it is necessary to prevent unreasonable conflicts with local subsistence hunting activities.

In enforcing this stipulation, the RS/FO will work with other agencies and the public to assure that potential conflicts are identified and efforts are taken to avoid these conflicts (for example, timing operations to avoid the bowhead whale subsistence hunt). These efforts might include seasonal drilling restrictions, seismic and threshold depth restrictions, and requirements for directional drilling and the use of other technologies deemed appropriate by the RS/FO.

Subsistence whaling activities occur generally during the following periods:

August to October: Kaktovik whalers use the area circumscribed from Anderson Point in Camden Bay to a point 30 kilometers north of Barter Island to Humphrey Point east of Barter Island. Nuiqsut whalers use an area extending from a line northward of the Nechelik Channel of the Colville River to Flaxman Island, seaward of the Barrier Islands.

September to October: Barrow hunters use the area circumscribed by a western boundary extending approximately 15 kilometers west of Barrow, a northern boundary 50 kilometers north of Barrow, then southeastward to a point about 50 kilometers off Cooper Island, with an eastern boundary on the east side of Dease Inlet. Occasional use may extend eastward as far as Cape Halkett.

f. Stipulation No. 6, Agreement Between the United States of America and the State of Alaska

This stipulation applies to the following blocks or portions of blocks referred to in this Notice as disputed: NR 05- 03, Teshekpuk, block 6024; NR 05-04, Harrison Bay, blocks 6001, 6421, 6423-6424, 6461-6463, 6470-6471, 6512-6515, 6562-6566, 6613-6614; NR 06-03, Beechey Point, blocks 6401, 6403, 6511-6514, 6562-6563, 6568-6570, 6612-6614, 6616, 6618-6621, 6663-6666, 6668-6669, 6718-6720, 6723-6724, 6768-6771, 6819-6820, 6870-6871, 6874, 6924; NR 06-04, Flaxman Island, blocks 6802-6803, 6857, 6901, 7014-7016, 7066-7067.

This lease is subject to the "Agreement Between the United States of America and the State of Alaska Pursuant to Section 7 of the Outer Continental Shelf Lands Act and

Alaska Statutes 38.05.137 for the Leasing of Disputed Blocks in Federal Outer Continental Shelf Oil and Gas Lease Sale 144 and State Oil and Gas lease Sale 86" (referred to as the "Agreement"), and the lessee hereby consents to every term of that Agreement. Nothing in that Agreement or this Notice shall affect or prejudice the legal position of the United States in *United States of America v. State of Alaska*, United States Supreme Court No. 84, Original.

Any loss incurred or sustained by the lessee as a result of obtaining validation and recognition of this lease pursuant to the Agreement, and in particular any loss incurred or sustained by the lessee as a result of conforming this lease with any and all provisions of all applicable laws of the party prevailing in *United States of America v. State of Alaska*, No. 84 Original, shall be borne exclusively by the lessee.

No taxes payable to the State of Alaska will be required to be paid with respect to this lease until such time as ownership of or jurisdiction over the lands subject to this lease is resolved. In the event that the lands subject to this lease or any portion of them are judicially determined to be State lands, the lessee shall pay to the State of Alaska a sum equivalent to the State taxes, which would have been imposed under Alaska law if the lands, or portion thereof determined to be State lands, had been undisputed State lands from the date the lease was executed, plus interest at the annual legal rate of interest provided under Alaska law accruing from the date the taxes would have become due under Alaska law. Such payment shall be in lieu of, and in satisfaction of, the actual State taxes.

g. Stipulation No. 7, Agreement Regarding Unitization

This stipulation applies to the following blocks or portions of blocks referred to in this Notice as disputed: NR 05- 03, Teshekpuk, block 6024; NR 05-04, Harrison Bay, blocks 6001, 6421, 6423-6424, 6461-6463, 6470-6471, 6512-6515, 6562-6566, 6613-6614; NR 06-03, Beechey Point, blocks 6401, 6403, 6511-6514, 6562-6563, 6568-6570, 6612-6614, 6616, 6618-6621, 6663-6666, 6668-6669, 6718-6720, 6723-6724, 6768-6771, 6819-6820, 6870-6871, 6874, 6924; NR 06-04, Flaxman Island, blocks 6802-6803, 6857, 6901, 7014-7016, 7066-7067.

This lease is subject to the "Agreement Regarding Unitization for the Outer Continental Shelf Oil and Gas Lease Sale 144 and State Oil and Gas Lease Sale 86 Between the United States of America and the State of Alaska", and the lessee is bound by the terms of that Agreement.

2. Stipulations Associated with a Proposal

Postlease mitigation requirements are those that have been applied to specific proposed actions for exploration, development, production, and site clearance activities before leases expire. These protective measures are specific to individual activities and are imposed following environmental reviews (according to the NEPA) of the OCS lease block location and potential resources. Special stipulations that limit operations are in addition to the lease-term stipulations.

Conditions of plan approval are mechanisms determined by MMS to control or mitigate potential environmental or safety problems associated with a proposal. Comments from other Federal and State agencies (as applicable) are considered during the review process. In addition, the MMS technical evaluations (including geological and geophysical; royalty, Suspension of Production schedule, and competitive reservoir considerations; potentially hazardous situations involving existing or proposed pipelines; conflicts with archaeological resources and sensitive biological areas, and other uses; and NEPA compliance) are considered.

Alternatives to the proposal are evaluated as part of the NEPA process to assess reasonable alternative activities that could result in lower adverse environmental impacts. In addition to alternatives proposed by the lessee/applicant, alternatives or mitigation that are not part of the proposal that may be needed to lessen environmental effects are given full consideration. Mitigating measures have addressed resource-use concerns such as endangered/threatened species, geologic and artificial hazards, air quality, oil-spill-contingency planning, and operations in H₂S-prone. Conditions that may be necessary to provide environmental protection may be applied to any OCS plan, permit, right of use of easement, or pipeline right-of-way grant.

3. Operational Stipulations that Apply to the Liberty Development Project, Development and Production Plan

Project or site-specific operational stipulations for the Liberty Plan may be imposed by the RSFO, as determined necessary by further analysis, as developed through the NEPA process, and in consultation with other Federal, State, and North Slope Borough regulatory and resource agencies. Other Federal, State, and North Slope Borough permits or other approvals also may be required by law or regulation for the Liberty Project Plan to proceed. These include permits issued to authorize discharges into the waters under the National Pollution Discharge Elimination System (NPDES) or permits issued for discharge of dredged

or fill material into navigable waters at specified disposal sites under Section 404 of the Clean Water Act, as amended. Specific permits issued by Federal agencies other than the MMS could include permit conditions that are more strict.

C. STATUTORY LAWS APPLICABLE TO MINERAL RESOURCE ACTIVITY ON THE OCS

Outer Continental Shelf Lands Act, as amended (43 U.S.C. § 1331 et seq.)
 Oil Pollution Act of 1990, as amended (33 U.S.C. § 2701 et seq.)
 National Environmental Policy Act of 1969, as amended (42 U.S.C. § 4321 et seq.)
 Endangered Species Act of 1973, as amended (16 U.S.C. § 1531 et seq.)
 Marine Mammal Protection Act of 1972, as amended (16 U.S.C. § 1361 et seq.)
 Coastal Zone Management Act of 1972, as amended (16 U.S.C. § 1451 et seq.)
 Federal Water Pollution Control Act, as amended (33 U.S.C. § 1251 et seq.)
 Deepwater Port Act of 1974, as amended (33 U.S.C. § 1501 et seq. and 43 U.S.C. § 1333)
 Clean Air Act, as amended (42 U.S.C. § 7401 et seq.)
 National Historic Preservation Act of 1966, as amended (16 U.S.C. § 470 et seq.)
 Ports and Waterways Safety Act of 1972, as amended (33 U.S.C. § 1221 et seq.)
 Marine Protection, Research, and Sanctuaries Act of 1972, as amended (33 U.S.C. § 1401-1445 and 16 U.S.C. § 1431-1445)
 Federal Oil and Gas Royalty Management Act of 1982 (30 U.S.C. § 1701 et seq.)
 Arctic Research and Policy Act of 1984 (15 U.S.C. § 4101 et seq.)

The OCS Report, MMS 86-0003, *Legal Mandates and Federal Regulatory Responsibilities* (Rathbun, 1986), incorporated here by reference, describes legal mandates and authorities for offshore leasing and outlines Federal regulatory responsibilities. This report contains summaries of the OCSLA, as amended, and related statutes and a summary of the requirements for exploration and development and production activities. The report also includes a discussion of significant litigation affecting OCS leasing policy. Since its publication in 1986, many of the laws and regulatory programs that are addressed in the report have been amended and updated to further address safety and environmental protection during oil and gas operations. The report is being updated. Included in OCS Report, MMS 86-0003 are the OCS orders that subsequently have been updated and placed in the consolidated operating regulations found in 30 CFR 250 (63 *Federal Register* 290477 5/29/98).

The OPA will be addressed in the next edition of that report. The OPA expands on the existing Clean Water Act and adds new provisions on oil-spill prevention, increases penalties for oil spills, and strengthens oil-spill-response capabilities. The OPA also establishes new oil-spill-research programs and provides special protection for selected geographic areas.

D. REGULATIONS APPLICABLE TO MINERAL RESOURCE ACTIVITY ON THE OCS

Federal agencies and their corresponding regulatory responsibilities that directly or indirectly affect OCS activities and are applicable to the review and coordination of the proposed activities relevant to the Liberty Plan are listed below. This list may not contain all the regulations. All published rules and regulations continue in effect and must be followed.

U.S. Department of Energy, 10 CFR 200-699
 U.S. Department of Commerce, NOAA, 15 CFR 900-999
 U.S. Department of the Interior, MMS, 30 CFR 200-299 (formerly 30 CFR Part 250 [63 *FR* 29477, 5/29/98])
 U.S. Department of Transportation, U.S. Coast Guard, 33 CFR 1-199, 46 CFR 1-199, and 49 CFR 400-499
 U.S. Department of Defense, U.S. Army Corps of Engineers, 33 CFR 200-399
 Advisory Council on Historic Preservation, 36 CFR 800-899
 U.S. Environmental Protection Agency, 40 CFR 1-239
 Council on Environmental Quality, 40 CFR 1500-1599
 Office of the Secretary of the Interior, 43 CFR 1-99
 U.S. Department of Commerce, NOAA, National Marine Fisheries Service, 50 CFR 200-299
 International Regulatory Agencies (Fishing and Whaling), 50 CFR 300-399
 U.S. Department of the Interior, Fish and Wildlife Service, National Marine Fisheries Service, and Endangered Species Committee, 50 CFR 400-499
 Marine Mammal Commission, 50 CFR 500-599

E. FEDERAL COMPENSATION FOR DAMAGES OR POLLUTION

1. Oil Spill Liability Trust Fund

Through the Oil Spill Liability Trust Fund (OSLTF), the OPA allows for compensation of loss or damages resulting from discharges, or substantial threats of discharges, of oil into or on the navigable waters or shorelines of the United

States or its Exclusive Economic Zone from a vessel or facility.

The OSLTF originally was established under Section 9509 of the Internal Revenue Code of 1986. It was one of several similar Federal trust funds funded by various levies set up to provide for the costs of water pollution. The OPA generally consolidated the liability and compensation schemes of these prior Federal oil pollution laws and authorized the use of the OSLTF, which consolidated the funds supporting those regimes. Those prior laws included the Federal Water Pollution Control Act; Trans-Alaska Pipeline Authorization Act; Deepwater Port Act; and the OCSLA.

The OPA allows for claims for uncompensated removal costs consistent with the National Oil and Hazardous Substances Pollution Contingency Plan (NCP) and damages resulting from an oil pollution incident to include the following:

- uncompensated removal costs;
- natural resource damages;
- real or personal property damages;
- loss of subsistence use of natural resources;
- net loss of Government revenues;
- loss of profits or impairment of earning capacity; and
- net costs of providing increased or additional public services.

The OPA has made two important changes to the previous funds. Both the size and, generally, the uses of the OSLTF have been increased beyond the scope of the previous funds. Its uses now include access to the Fund by the States; payments to the Federal, State, and Indian Tribe trustees to carry out natural resource damage assessments and restorations; and payment of claims for uncompensated removal costs and damages. The OSLTF can provide up to \$1 billion per incident for uncompensated cleanup costs and can compensate oil-spill victims when liability limits have been reached or if the spiller and an injured party cannot reach an agreement on a settlement. The OSLTF receives funds from four primary sources:

- An oil tax (5 cents a barrel on domestically produced or imported oil collected from the oil industry; this is suspended when the fund reaches \$1 billion but may be reinstated if the fund falls below this amount).
- Interest on fund principal.
- Cost recovery from responsible parties (the parties responsible for oil spills are liable for costs and damages. All monies recovered go either back to replenish the Fund or to the U.S. Treasury).
- Penalties (to include civil penalties assessed to the responsible parties).

The OSLTF is used to cover a variety of needs and provides payment of the following:

- Removal costs (including costs of monitoring, removal actions, and abating substantial threat) consistent with the NCP.

- Costs incurred by the trustees for natural resource damage assessments and developing and implementing plans to restore, rehabilitate, replace, or acquire equivalent natural resources consistent with the NCP.
- Claims for uncompensated removal costs consistent with the NCP and for compensated damages.
- Federal administrative and operational costs, including research and development.

To better address funding needs, the OSLTF has been subdivided into an Emergency Fund and a Principal Fund. The Emergency Fund ensures rapid and effective response to oil spills without requiring further Congressional appropriations. Through this portion of the OSLTF, up to \$50 million is provided each year to fund removal activities and to initiate natural resource damage assessments. Money available in the Emergency Fund also includes a carryover from prior years. This portion of the OSLTF (the Emergency Fund) may be used for the following removal actions and costs/services:

Removal Actions:

- containing and removing oil from water and shorelines
- preventing or lessening oil pollution where there is a substantial threat of discharge
- taking other actions related to lessening the damage to public health and welfare

Removal Costs/Services:

- contract services (for example, cleanup contractors and administrative support to document removal actions)
- salaries for Government personnel not normally available for oil-spill responses and for temporary Government employees hired for the duration of the spill response
- equipment used in removals
- chemical testing required to identify the type and source of oil
- proper disposal of recovered oil and oily debris

The Principal Fund (exclusive of the Emergency Fund) can be used to pay claims without further appropriation and may be used for other actions when Congress appropriates the funds. Such additional actions may include Federal administrative, operational, and personnel costs; natural resource damage assessments and restoration; and research and development.

On February 20, 1991, the National Pollution Funds Center (NPFC) was commissioned to serve as fiduciary agent for the OSLTF. Because the Federal On-Scene Coordinators need funds immediately to respond directly to a spill or to monitor responsible parties' actions, the NPFC established a system to provide funds 24-hours a day. In addition to dispersing funds for removal actions, the NPFC also administers the OSLTF by monitoring the use of funds, by processing third-party claims submitted to the OSLTF, and by pursuing cost recovery from responsible parties for removal costs and damages paid by the OSLTF. Generally,

the owner or operator of the vessel or facility that is the source of a discharge or substantial threat of a discharge will be liable for removal costs and damages resulting from an oil-spill incident. Therefore, claimants first must seek reimbursement from the responsible party or guarantor. If a claimant is dissatisfied with the actions of the responsible party/guarantor with respect to the claim, the claimant may choose to litigate against the responsible party or submit the claim to the OSLTF. Claims against the OSLTF for removal costs must be submitted within 6 years after the date of completion of all removal actions for the incident. Claims for damages must be made within 3 years after the date on which the injury and its connection with the incident were reasonably discoverable or, in the case of natural resource damages under Section 1002(b)(2)(A) of OPA (33 U.S.C. 2702(b)(2)(A)), the same timeframe as above or within 3 years from the date of completion of the natural resource damage assessment, whichever is later. The controlling legal authority for OSLTF claims can be found in OPA (33 U.S.C. 2701 et seq.) and that statute's implementing regulations at 33 C.F.R. 136.

2. Oil-Spill-Financial Responsibility

In addition to the establishment of the OSLTF, responsible parties also must maintain oil-spill-financial responsibility (OSFR) for removal costs and compensation damages. Title I of OPA (33 U.S.C. 2701 et seq.), as amended by Section 1125 of the Coast Guard Authorization Act of 1996 (Pub. L. 104-324), provides at Section 1016 that parties responsible for offshore facilities must establish and maintain OSFR for those facilities according to methods determined acceptable to the President. Section 1016 supersedes the OSFR provisions of the OCSLA. The Executive Order (E.O.) implementing OPA (E.O. 12777; October 18, 1991) assigned the OSFR certification function to the U.S. Department of the Interior (USDOI). The Secretary of the Interior, in turn, delegated this function to the MMS.

To implement the authority of the OPA, the final rule on Oil-Spill-Financial Responsibility for Offshore Facilities was published on August 11, 1998, in the *Federal Register* (63 FR 42699). These regulations, administered by MMS under 30 C.F.R. Parts 250 and 253 and became effective October 13, 1998, establish new requirements for demonstrating OSFR for removal costs and damages caused by oil discharges and substantial threats of oil discharges from oil and gas exploration and production facilities and associated pipelines. This rule applies to certain crude-oil wells, production platforms, and pipelines located in the OCS, State waters seaward of the line of ordinary low water along that portion of the coast that is in direct contact with the open sea, and certain coastal inland waters. Parties responsible for offshore facilities must establish and maintain OSFR for those facilities according to methods determined acceptable to the President.

These regulations replace the current OSFR regulation at 33 C.F.R. part 135, which was written to implement the OCSLA. The OCSLA regulation is limited to facilities located in the OCS and sets the amount of OSFR that must be demonstrated by responsible parties at \$35 million. The new rule covers facilities in both the OCS and certain State waters. It requires responsible parties to demonstrate as much as \$150 million in OSFR, if the MMS determines that it is justified by the risks from potential oil spills from covered offshore facilities (COF's).

The minimum amount of OSFR that must be demonstrated is \$35 million for COF's located in the OCS and \$10 million for COF's located in State waters. The regulation provides an exemption for persons responsible for facilities having a potential worst-case oil-spill discharge of 1,000 barrels or less, unless the risks posed by a facility justify a lower threshold volume.

Also contained within the regulations are procedures for filing claims for spill-related compensation. In most cases, claims first must be presented to the responsible party that is the source of the incident resulting in the claim or its insurer, unless the United States issues notice that claims should be presented to the Fund. Claimants may be compensated for loss of subsistence use of natural resources.

F. STATE COMPENSATION FOR DAMAGES OR POLLUTION

State of Alaska's Oil and Hazardous Substance Release

Fund: The State of Alaska provides municipal impact grants (when authorized under AS 29.60.510(b)(2)) from the State's oil- and hazardous-substance-release fund. This fund is composed of two accounts: (1) the oil- and hazardous-substance release-prevention account, and (2) the oil- and hazardous-substance release-response account. The primary purpose of the fund is to provide grants to affected villages and municipalities to compensate for loss or damages resulting from a release or threatened release of oil or hazardous substances to subsistence resources and other spill-related expenses. Claims for damage or loss by subsistence-resource users may not be paid from these grants. Individuals must submit their claims to the party responsible for the loss or damage.

On January 5, 1996, pursuant to Section 1006(e) of the OPA, the National Oceanic and Atmospheric Administration (NOAA) promulgated regulations for the assessment of natural resource damages resulting from a discharge or substantial threat of a discharge of oil. These final regulations, codified at 15 C.F.R. Part 990, were published at 61 FR 440. The NOAA provides a damage assessment process to develop a plan to restore the injured natural resources and services and for the implementing or funding of the plan by responsible parties. The NOAA also provides an administrative process to involve interested

parties in the assessment, a range of assessment procedures to identify and evaluate injuries to natural resources and services, and a means to select restoration actions from a reasonable range of alternatives.

The MMS Alaska OCS Region Reference Paper No. 83-1, *Federal and State Coastal Management Programs* (McCrea, 1983), incorporated here by reference, describes the coastal management legislation and programs of both the Federal Government and the State of Alaska. This paper highlights sections particularly relevant to offshore oil and gas development and briefly describes some of the effects of the Alaska Native Claims Settlement Act and the Alaska National Interest Lands Conservation Act on coastal management.

Following the 1984 Memorandum of Understanding between the Environmental Protection Agency (USEPA) and the USDOJ concerning the coordination of NPDES permit issuance with the OCS oil and gas lease program, the MMS Alaska OCS Region and the USEPA, Region 10 entered into a Cooperating Agency Agreement to prepare environmental impact statements for oil and gas exploration and development and production activities on the Alaskan OCS. Section 402 of the Clean Water Act authorizes the USEPA to issue NPDES permits to regulate discharges to waters of the United States, including the territorial seas, contiguous zone, and oceans. The NPDES permits for OCS oil and gas facilities many contain effluent limitations developed pursuant to sections of the Clean Water Act, including Sections 301, 302, 306, 307, and 403. Under the offshore subcategory of the Clean Water Act, the USEPA may have responsibilities under the NEPA for permits issued to new sources (Sec. 306 of the Clean Water Act) that overlap those of MMS. The USEPA's primary role in the Cooperating Agency Agreement is to provide expertise in those fields specifically under its mandate.

In conjunction with the issuance of an NPDES permit, the USEPA is responsible for publishing an Ocean Discharge Criteria Evaluation (ODCE), which evaluates the impacts of waste discharges proposed for oil and gas projects. The purpose of the ODCE is to demonstrate whether or not a particular discharge will cause unreasonable degradation to the marine environment.

G. INDIAN TRUST RESOURCES

The USDOJ and the MMS are responsible for ensuring that trust resources of federally recognized Indian Tribes and their members that may be affected by these project activities are identified, cared for, and protected. No significant impacts were identified during the EIS scoping process. Native allotments in the project area are discussed in Section III.C.3.i(3).

H. ENVIRONMENTAL JUSTICE

Executive Order 12898 requires that Federal agencies identify and address disproportionately high and adverse human health and environmental effects of its actions on minority and low income populations. The principal goal of the Executive Order is to promote fair treatment of minorities and the poor, so that no group of people bears an unequal share of environmental or health impacts from Federal actions. The Native Alaskan (Inupiat) population, a minority group, is predominant in the North Slope Borough and may be affected by the Liberty Project's construction and production. The culture of this indigenous population is closely tied to the environment and subsistence use.

Scoping meetings were held in the North Slope Native communities of Barrow, Nuiqsut, and Kaktovik to solicit information from residents who may be affected by the Liberty Project's construction and production on what they felt should be addressed in the EIS. Translators were available at these meetings to communicate information in both Inupiaq and English. Followup meetings were held in these same communities by MMS to present the summary results of scoping (issues and alternatives) that would be highlighted in the EIS. See the Scoping Report in Appendix E for more information.

A Participating Agency Agreement was signed in early 1998, which established a working relationship between the North Slope Borough and MMS in the preparation of the EIS. By this agreement, the Borough agreed to fully participate in all phases of the EIS preparation, including collecting indigenous (traditional) knowledge, developing project alternatives, and identifying and reviewing analyses of impacts in the EIS.

The environmental justice concerns raised during scoping are covered in this EIS in the sections analyzing the effects on Subsistence-Harvest Patterns, Sociocultural Systems, and marine mammals (see Sec. III.C.3.i(6) for a discussion of environmental justice). The analyses in these sections incorporate "traditional knowledge" of the Inupiat people of the North Slope communities of Barrow, Nuiqsut, and Kaktovik, along with Western scientific knowledge.

Table B-1 Permits and Approvals Required for Liberty Development

Agency	Permit/Approval	Activity/Comments
Federal Agencies		
Federal Agencies	NEPA Compliance	NEPA review required before Federal permits can be issued
U.S. Army Corps of Engineers (COE)	Section 10 (Rivers and Harbors Act)	Island and pipeline construction; barge camp facility
COE	Section 404 (Clean Water Act)	Pipeline backfill in State waters and onshore; onshore pad construction; fill placed for mine site development and rehabilitation
U.S. Environmental Protection Agency (USEPA)	NPDES Individual	Point wastewater discharges
USEPA	NPDES (General Storm water, Construction/Industrial Activity)	Storm water drainage-onshore construction and operations
COE/USEPA	Section 103 (Marine Protection, Research, and Sanctuaries Act)	Transport of dredged material for the purpose of dumping it into ocean waters
MMS	Development and Production Plan	Construction, drilling, and operations
MMS	Right of use and easement grants	Construct and maintain lease platforms, artificial islands, all installations, and other devices used for conducting exploration, development, and production activities or other operations related to such activities in/or on Federal waters (i.e., pipelines, pipeline rights-of way, platforms, etc.)
MMS	Permit to Drill	All wells, including waste injection well
USEPA	Part 55 Air Permit	Emissions from island construction, construction and operation, including vessel traffic
National Marine Fisheries Service (NMFS)	Incidental Harassment of Marine Mammals (whales and seals)	Marine construction
NMFS	Letter of Authorization for Incidental Take of Marine Mammals (whales and seals)	Construction and operations
Fish and Wildlife Service	Letter of Authorization for Incidental Take of Marine Mammals (polar bears and the Pacific walrus)	Construction and operations
U.S. Coast Guard	Oil Discharge Prevention and Contingency Plan	Construction, drilling, operations (fuel transfer)
State Agencies		
Dept. of Natural Resources (DNR), State Pipeline Coordinator's Office	Right-of-Way Lease	Pipeline construction and operations in State waters and lands
DNR, Division of Lands	Material Sales Contract	Gravel mining and purchase
DNR, Division of Lands	Miscellaneous Land Use (ice roads)	Construction and operations
Department of Environmental Conservation (DEC)	Oil Discharge Prevention and Contingency Plan	Pipeline operations
DEC	Section 401 Water Quality Certification	All construction under COE Section 404 permit (certification)
DEC	Request for Temporary Water Quality Variance	Construction activities in marine waters
Department of Fish and Game	Title 16 Fish Habitat	Mine site development
Division of Governmental Coordination	Coastal Zone Consistency	Construction and operations (certification on all Federal and State permits)
Local Agencies		
North Slope Borough	Rezoning-Conservation District to Resource Development District	Construction and operations

Table B-2 Time Periods and Lease Blocks in Which Stipulation 4 (Bowhead Whale Monitoring) Applies

Official Protraction Diagram	Blocks
Spring Migration Area, April 1 through June 15	
NR 05-01, Dease Inlet	6004–6011, 6054–6061, 6104–6111, 6154–6167, 6204–6220, 6254–6270, 6304–6321, 6354–6371, 6404–6423, 6454–6473, 6504–6523, 6554–6573, 6604–6623, 6654–6673, 6717–6723
NR 05-02, Harrison Bay North	6401–6404, 6451–6454, 6501–6506, 6551–6556, 6601–6612, 6651–6662, 6701–6716
Central Fall Migration Area, September 1 through October 31	
NR 05-01, Dease Inlet	6704–6716, 6754–6773, 6804–6823, 6856–6873, 6908–6923, 6960–6973, 7011–7023, 7062–7073, 7112–7123
NR 05-03, Teshekpuk	6015–6024, 6067–6072
NR 05-02, Harrison Bay North	6751–6766, 6801–6818, 6851–6868, 6901–6923, 6951–6973, 7001–7023, 7051–7073, 7101–7123
NR 05-04, Harrison Bay	6001–6023, 6052–6073, 6105–6123, 6157–6173, 6208–6223, 6258–6274, 6309–6324, 6360–6374, 6410–6424, 6461–6471, 6512–6519, 6562–6566, 6613–6614
NR 06-01, Beechey Point North	6901, 6951, 7001, 7051–7062, 7101–7113
NR 06-03, Beechey Point	6002–6014, 6052–6064, 6102–6114, 6152–6169, 6202–6220, 6251–6274, 6301–6324, 6351–6374, 6401–6424, 6456–6474, 6509–6524, 6568–6574, 6618–6624, 6671–6674, 6723–6724, 6773
NR 06-04, Flaxman Island	6301–6303, 6351–6359, 6401–6409, 6451–6459, 6501–6509, 6551–6559, 6601–6609, 6651–6659, 6701–6709, 6751–6759, 6802–6809, 6856–6859
Eastern Fall Migration, August 1 through October 31	
NR 06-04, Flaxman Island	6360–6364, 6410–6424, 6460–6474, 6510–6524, 6560–6574, 6610–6624, 6660–6674, 6710–6724, 6760–6774, 6810–6824, 6860–6874, 6910–6924, 6961–6974, 7013–7022, 7066–7070, 7118–7119
NR 07-03, Barter Island	6401–6405, 6451–6455, 6501–6505, 6551–6555, 6601–6605, 6651–6655, 6701–6705, 6751–6755, 6801–6805, 6851–6855, 6901–6905

APPENDIX C

ENDANGERED SPECIES ACT, SECTION 7 CONSULTATION AND COORDINATION

- C-1 NOAA/National Marine Fisheries Service Endangered Species Act, Section 7 Biological Opinion for BP Exploration's Proposed Liberty Development and Production Plan**
- C-2 Fish and Wildlife Service Endangered Species Act, Section 7 Biological Opinion for BP Exploration's Proposed Liberty Development and Production Plan**

**NOAA/National Marine Fisheries Service Endangered Species
Act, Section 7 Biological Opinion for BP Exploration's Proposed
Liberty Development and Production Plan**



UNITED STATES DEPARTMENT OF COMMERCE
National Oceanic and Atmospheric Administration
NATIONAL MARINE FISHERIES SERVICE
Silver Spring, MD 20910

DEC 12 2001

Lucy Querques Denett
Director
Offshore Minerals Management
Minerals Management Service
Washington, D.C. 20240

Dear Ms. Denett:

This document transmits the National Marine Fisheries Service's (NMFS) biological opinion based on our review of the proposed Liberty project in the U.S. Beaufort Sea off Alaska's north coast, and its effects on the bowhead whale in accordance with section 7 of the Endangered Species Act of 1973, as amended (16 U.S.C. 1531 *et seq.*). Through informal consultation, our agencies had determined that bowhead whales are the only listed species, for which NMFS bears responsibility, that would be adversely affected by this work. No designated critical habitat occurs in the area that may be affected by the proposed Liberty project.

The Minerals Management Service (MMS) initiated section 7 consultation on the Liberty project on February 19, 1998, by requesting information on endangered and threatened species and critical habitat. NMFS received your request for formal consultation on March 2, 2001. This biological opinion is based on information provided in your February 26, 2001, biological assessment, the January 2001 draft Environmental Impact Statement on the proposed Liberty project, and other sources of information. A complete administrative record of this consultation is on file at the Anchorage field office of NMFS.

After reviewing the relevant information available on the biology and ecology of bowhead whales in the action area and the direct and indirect effects of the proposed Liberty project, NMFS concludes that the proposed project is not likely to jeopardize the continued existence of the bowhead whale. To formulate this opinion, NMFS used the best available information, including information provided by



MMS, recent research on the effects of oil and gas activities on the bowhead whale, and the traditional knowledge of Native hunters and the Inupiat along Alaska's north slope. Conservation recommendations are provided with the opinion which are intended to improve our understanding of the impacts of oil and gas activities on the bowhead whale, as well as to minimize or mitigate adverse effects.

An Incidental Take Statement (ITS) is necessary to exempt MMS and the applicant from the prohibitions of section 9 of the ESA. An ITS can be issued only after the applicant has received authorization under section 105 of the Marine Mammal Protection Act. When that permitting is completed, we will amend this opinion by including the ITS.

Sincerely,

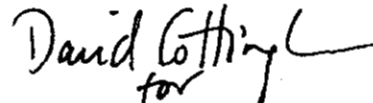
A handwritten signature in cursive script that reads "David Gotting". The signature is written in dark ink and includes a long horizontal flourish at the end.

for
Donald R. Knowles
Director,

Office of Protected Resources

ENDANGERED SPECIES ACT SECTION 7 CONSULTATION BIOLOGICAL OPINION

Action Agency: Department of the Interior, Minerals Management Service

Activity: Construction and Operation of the Liberty Oil Production Island
[Consultation No. F/AKR/2001/00859]

Consulting Agency: National Marine Fisheries Service, Alaska Region, Office of Protected Resources

Approved by: /s/

Date: December 12, 2001

This document represents National Marine Fisheries Service's biological opinion (Opinion) on the Minerals Management Service's (MMS) proposed approval of a development and production plan for the construction and operation of the Liberty project in the U.S. Beaufort Sea off Alaska's north coast and its effects on the endangered bowhead whale *Balaena mysticetus* in accordance with section 7 of the Endangered Species Act of 1973, as amended (ESA) (16 U.S.C. 1531 et seq.). Formal section 7 consultation with the MMS was initiated on March 2, 2001.

This Opinion is based on information provided by the MMS in their *Draft environmental Impact Statement (DEIS)* on the Liberty Development and Production Plan released in January 2001, the biological assessment dated February 26, 2001, recent research on the effects of oil and gas activities on the bowhead whale, traditional knowledge of Native hunters and the Inupiat along Alaska's north slope, and other sources of information. A complete administrative record of this consultation is on file at the NMFS Alaska Regional Office, Office of Protected Resources, Anchorage, Alaska [Consultation No. F/AKR/2001/008893].

Consultation History

The Minerals Management Service (MMS) initiated Endangered Species Act (ESA) section 7 on the Liberty project on February 19, 1998, which it requested information on endangered and threatened species and critical habitat in the area affected by the proposal. NMFS' Office of Protected Resources, Alaska Regional Office, subsequently responded to this request. On February 26, 2001, the MMS submitted a biological

assessment to NMFS' Alaska Regional Office and requested formal consultation. Formal section 7 consultation was initiated on the Liberty Project on March 2, 2001.

Under section 7 of the ESA, NMFS has prepared this biological opinion to evaluate the impacts of the Liberty project on the endangered bowhead whale, and to determine whether activities associated with the Liberty project are likely to jeopardize its continued existence. This biological opinion incorporates much of the information presented within the biological evaluation prepared by MMS as well as pertinent research on the bowhead whale and matters related to oil development. Traditional knowledge and the observations of Inupiat hunters are presented. This knowledge contributes, along with western science, to a more complete understanding of these issues. A reasonable assessment of potential effects can only be made by considering both these systems of knowledge.

I. Description of the Proposed Action

British Petroleum Exploration, Alaska (BPXA), proposes to develop and produce oil and gas from the Liberty oil field and has applied to the Minerals Management Service (MMS) for approval of the Liberty Development and Production Plan. The Liberty Prospect is in Federal Outer Continental Shelf (OCS) waters of Foggy Island Bay in the Beaufort Sea northeast of Prudhoe Bay's oil fields. In January 2001, the MMS released a draft Environmental Impact Statement (DEIS) for the proposed development (USDO, MMS 2001). A complete description of the proposed project can be found in this DEIS, incorporated here by reference. The MMS also prepared a biological evaluation of the Liberty project which addressed the effects of this project on threatened and endangered species.

If approved, the Liberty Project would be a self-contained oil production operation with full processing facilities on a 22.4-acre man-made gravel island. A buried sub-sea pipeline would connect the island with the Trans Alaska Pipeline System at Prudhoe Bay, Alaska. Liberty Island would be located in Foggy Island Bay in 22 feet of water. Ice roads would be built through the life of the project to provide vehicle access to the island during solid-ice conditions. While the island is constructed (starting in December of Year 1 and continuing through project startup in November of Year 3), offshore and onshore ice roads will provide access to the island and pipeline during construction in the winter. Up to 400 round trips over these roads are expected to occur every day while the island is constructed and 400 round trips each winter while drilling is underway. After drilling, the number of trips would drop to 100 each winter season.

Helicopters, barges or supply boats, and vehicles using ice roads would transport personnel, material, diesel fuel, and facilities to Liberty Island. Seagoing barges would carry large modules and other supplies and equipment from Southcentral Alaska.

The majority of waste generated during construction and developmental drilling would be drill cuttings and spent muds. Some waste also would be generated during operations from well-workover activities. These drilling fluids would be disposed of through onsite injection into the disposal well or would be transported offsite to permitted disposal

wells. BPXA proposes zero discharge of drilling waste to lessen discharges into the Beaufort Sea.

BPXA estimates that the target reservoir may contain 120 million barrels of recoverable oil. Production is expected to continue for about 15 years.

Following depletion of the field, wells would be plugged and abandoned, and production and other surface facilities removed. Disposition of the subsea pipeline would be based on an evaluation of the impacts of the options at the time of abandonment. At a minimum, the portion of the pipeline contained in the island would be removed. Based on the conditions at the time, including relevant permit stipulations, laws, regulations, and policies, BPXA would develop a detailed abandonment plan for agency review and approval. A likely scenario for island abandonment would involve removing island facilities and slope protection, including gravel-filled bags, and allowing the island to erode naturally. The onshore portion of the pipeline, the vertical support members, and other surface equipment would be removed. Abandonment of the landfall and Badami tie-in gravel pads would be determined at that time. Because plans for abandonment remain to be determined, additional section 7 consultation will be necessary for this related action. Additional details on specific aspects of the proposed development and production activities are given below and in the Liberty Development and Production Plan Draft EIS.

Proposed Activities

Major features associated with the development and operation of the Liberty project include:

- construction of a gravel island in 22 feet of water during the second year of development.
- construction of ice roads between the mainland and the island site.
- movement of infrastructure and process modules via sealifts to the island in July/August of Year 2 and Year 3, respectively.
- construction of a 12-inch oil pipeline in Year 3, to be buried in a trench from the island to an onshore landfall. The total pipeline length would be approximately 6.1 miles, with about 4.6 miles offshore.
- development drilling from the first quarter of Year 3 to the first quarter of Year 5.
- start production in Year 4; the economic field life currently is estimated to be approximately 15 years. Average peak production would be 65,000 barrels per day.

Action Area

The action area for this Biological Opinion is the Alaskan Beaufort Sea, extending from Point Barrow to Demarcation Point and from the Alaska coastline to the edge of the continental shelf. NMFS expects the direct and indirect effects of this action on the endangered bowhead whale to be confined to the action area. Although additional, indirect effects of the proposed action may extend beyond this action area, such as possible effects associated with vessel traffic from the port of Valdez and to ports

receiving petroleum transported from Valdez, we do not believe we would be able to meaningfully measure, detect, or evaluate these effects. As such, those effects are considered "insignificant effects" (as defined in the Interagency Handbook on Section 7 Consultations; NMFS/FWS 1998) and, consequently, will not be included in the action area for the proposed action.

II. Status of Listed Species and Designated Critical Habitat (rangewide)

The MMS biological assessment considered the potential effects of the Liberty project on various species listed or proposed for listing under the ESA. That assessment concluded (for those species for which the NMFS bears responsibility) that the Liberty project was not likely to adversely affect any listed species or critical habitat other than the bowhead whale. Species which MMS determined were not likely to be adversely affected by activities associated with the Liberty project include the Steller sea lion, Upper Columbia River Spring-run chinook salmon, Central Valley California Spring-run chinook salmon, California coastal chinook salmon, Central Valley fall/late-run chinook salmon, Puget Sound chinook salmon, Lower Columbia River chinook salmon, Columbia River chum salmon, Hood Canal summer-run chum salmon, Oregon coast coho salmon, Lower Columbia River/ chinook salmon, Puget Sound/Strait of Georgia coho salmon, Central California coast coho salmon, Ozette Lake Sockeye salmon, Lower Columbia River steelhead, California Central Valley steelhead, South-Central California Coast steelhead, Southern California steelhead, Central California Coast steelhead, Middle Columbia River steelhead, Northern California steelhead, and white abalone. These species occur in the Gulf of Alaska and/or North Pacific Ocean and were included in MMS' biological assessment because of the secondary impacts of the Liberty project; specifically marine shipment of Liberty crude oil from Valdez, Alaska to southern ports. MMS determined that these species were unlikely to be adversely affected by oil produced at Liberty and transported by tanker to ports on the U.S. west coast or in the Far East. Their determination was based on the reasoning that oil produced from the Liberty project represents a small proportion (1%) of past, present, and reasonably foreseeable future production from the North Slope and the Beaufort Sea and about 1% of potential tanker spills for oil transported by tanker from Valdez. If a spill did occur, MMS determined that it would be unlikely that the above named above named species along transportation routes would be adversely affected. Previous studies show that the chance of one or more spills occurring and contacting land along the U.S. coast adjacent to the Trans-Alaska Pipeline System tanker route is less than or equal to 3% (LaBelle et al., 1996). Based on the combined probabilities which account for the percentage of Liberty crude aboard a vessel, the chance of a spill occurring, and the chance of that spill reaching any of these species is small, MMS determined that potential impacts should be considered as discountable effects under the ESA.

NMFS has reviewed the information in MMS' biological assessment in support of their determination that the above named species are not likely to be adversely affected by the proposed approval of the Liberty Development and Production Plan. Based on this review, and other sources of information, NMFS concurs that Steller sea lions, Upper Columbia River Spring-run chinook salmon, Central Valley California Spring-run chinook salmon, California coastal chinook salmon, Central Valley fall/late-run chinook

salmon, Puget Sound chinook salmon, Lower Columbia River chinook salmon, Columbia River chum salmon, Hood Canal summer-run chum salmon, Oregon coast coho salmon, Lower Columbia River/ chinook salmon, Puget Sound/Strait of Georgia coho salmon, Central California coast coho salmon, Ozette Lake Sockeye salmon, Lower Columbia River steelhead, California Central Valley steelhead, South-Central California Coast steelhead, Southern California steelhead, Central California Coast steelhead, Middle Columbia River steelhead, Northern California steelhead, and white abalone may be affected, but are not likely to be adversely affected by activities associated with the development and production of the Liberty Project. Our concurrence is based on our belief that we would not be able to meaningfully measure, detect, or evaluate indirect effects associated with the shipping activities. Since the potential for a spill occurring during shipping of Liberty crude is small and unlikely to occur, we anticipate that effects to listed species associated with the shipping of Liberty crude to be "insignificant" (as defined in the Interagency Handbook on Section 7 Consultations; NMFS/FWS 1998).

NMFS concurs that the only threatened or endangered species under its jurisdiction which may be adversely affected by the proposed Liberty development within the action area is the endangered bowhead whale (*Balaena mysticetus*). Although NMFS is currently evaluating a petition to designate portions of the Beaufort Sea as critical habitat for this species (FR Vol 66, No. 99), critical habitat for this species has not been designated or proposed within the action area.

Status and distribution of Bowhead Whales

The bowhead whale was historically found in all arctic waters of the northern hemisphere. Five stocks are currently recognized by the International Whaling Commission (IWC, 1992:27). Three of these stocks are found in the North Atlantic and two in the North Pacific, some or all of which may be reproductively isolated (Shelden and Rugh, 1995). The Spitsbergen stock is found in the North Atlantic east of Greenland in the Greenland, Kara, and Barents Seas. Thought to have been the most numerous of bowhead stocks (Woodby and Botkin, 1993 estimate the unexploited stock at 24,000 animals), the Spitsbergen bowhead is now severely depleted, possibly in the tens of animals (Shelden and Rugh, 1995).

The Davis Strait stock is found in Davis Strait, Baffin Bay, and along the Canadian Arctic Archipelago. This stock is separated from the Bering Sea stock by the heavy ice found along the Northwest passage (Moore and Reeves, 1993). The stock was estimated to have originally numbered over 11,700 (Woodby and Botkin, 1993) but was significantly reduced by commercial whaling between 1719 and 1915. The stock is today estimated at 350 animals (Zeh et al., 1993) and recovery is described as "at best, exceedingly slow" (Davis and Koski, 1980). Canadian Inuit have recently expressed interest in resuming subsistence hunting of this stock, although the International Whaling Commission (IWC) has not acted on this request.

The Hudson Bay stock is differentiated from the Davis Strait stock by their summer distribution, rather than genetic or morphological differences (Reeves et al., 1983; Reeves and Mitchell, 1990). No reliable estimate exists for this stock, however Mitchell

(1977) places a conservative estimate at 100 or less. More recently, estimates of 256-284 whales have been presented for the number of whales within Foxe Basin (Cosens et al. 1997). There has been no appreciable recovery within this stock.

The Okhotsk Sea stock occurs in the North Pacific off the western coast of Siberia near the Kamchatka Peninsula. The pre-exploitation size of this stock may have been 3,000 to 6,500 animals (Shelden and Rugh, 1995), and may now number somewhere in the 300-400 range, although reliable population estimates are not currently available. It is possible this stock has mixed with the Bering Sea stock, although the available evidence indicates the two stocks are essentially separate (Moore and Reeves, 1993).

The Bering Sea stock of the bowhead whale is the only listed species under the jurisdiction of the National Marine Fisheries Service which is known to occur in the action area and which is likely to be adversely affected by the proposed Liberty project. There is no designated critical habitat in the action area. The bowhead whale was listed as a Federal endangered species on June 2, 1970 (35 FR 8495). The Bering Sea stock of bowhead is hunted by native Alaskans of the Alaskan Beaufort Sea coast for subsistence. In 1964, the IWC began to regulate commercial whaling worldwide (Burns et al., 1993:7). The bowhead gained further protection when the ESA and the Convention on International Trade in Endangered Species of wild flora and fauna were passed in 1973. Since 1978, the IWC has imposed a quota on the number of bowheads landed and/or struck by Alaskan natives. The IWC recently allocated the subsistence take of bowheads from the Alaska stock, establishing a 5-year block quota of 280 whales landed. For each of the years 1998-2002, the number of bowheads struck may not exceed 67, except that certain unused quotas may be carried over to subsequent years. Additionally, an annual quota of five bowheads has been granted to the Russian Federation for the Natives of Chukotka.

The Bering Sea stock of bowhead whales was reduced greatly by commercial whaling in the late 19th and early 20th centuries, from an estimated original population of 10,400 to 23,000 (Woodby and Botkin, 1993:403) to a few thousand by about 1910. Whales taken by commercial whaling in the Bering Sea may have been representatives of a population that did not migrate (Bockstoce and Botkin, 1983; Bockstoce, 1986). Shore-based visual surveys conducted at Point Barrow from 1978 through 1983 yielded a population estimate for that period of about 3,500 to 5,300 animals (Zeh et al., 1993:479). The IWC Scientific Committee now recognizes the current population estimate to be 7,992 whales (95% C.I.: 6,900-9,200) (IWC, 1995). A refined and larger sample of acoustic data from 1993 has resulted in an estimate of 8,200 animals, and is considered a better estimate for this stock (IWC, 1996). An annual rate of increase of 3.1% was computed for the Bering Sea stock.

Bowhead whales are seasonal and transient in the western Beaufort Sea, migrating from west to east in spring and back in fall. Most of the population winters along the ice front and in polynyas (irregular areas of open water) of the central and western Bering Sea (Moore and Reeves, 1993:410). About April or May, whales begin moving north past St. Lawrence Island and through Bering Strait into the southern Chukchi Sea, then north through nearshore lead systems to Point Barrow (Moore and Reeves, 1993:336). Some

bowhead whales also move north along the Chukotka coast of Russia. Behavior and timing are fairly consistent with bowheads passing Point Barrow in several "pulses:" the first between late April and early May, a second about mid-May, and a third from late May through early June (Moore and Reeves, 1993:337; A. Brower in USDOI, 1986:49; B. Rexford in MBC, 1997:80). Whaling crews have observed that the migrating whales appear to have 'scouts' which check ice conditions in advance of the main migration (C. Nageak in NSB 1981:296; W. Bodfish in NSB, 1981:297; L. Kingik in NSB, 1981:297). Whaling crews also have noticed that not all bowhead whales migrate into the Chukchi or Canadian Beaufort Seas, but that some bowheads remain near Barrow in summer (H. Brower, Jr. in USDOI, MMS, 1995:40).

Most whales move eastward from Point Barrow through offshore lead systems of the central Beaufort Sea (W. Bodfish in NSB, 1981:295). They appear in leads offshore of the Alaskan Beaufort Sea by early May (W. Bodfish in NSB, 1981:295), but apparently do not stop along the spring migration route (V. Nauwigewauk in NSB, 1981:295; A. Oenga in NSB, 1980:182). However, Sheldon and Rugh (1995:13) report some whales feed opportunistically during spring migration, and that the lead system may serve as an important feeding area when oceanographic conditions are favorable. The bowheads arrive in the Canadian Beaufort Sea from about mid-May through mid-June (Moore and Reeves, 1993:314). During migration, bowheads may swim under the ice for several miles, and can break through relatively thin ice (approximately 7 inches [18 cm] thick), to breathe (George et al., 1989:26). It is possible that bowheads use ambient light cues and possibly echos from their calls to navigate under ice and to distinguish thin ice from thick, multi-year floes (MMS, 1995). The spring migration ends at Herschel Island in the Canadian Beaufort Sea (V. Nauwigewauk in NSB, 1981:295).

Most of the bowhead population is concentrated in the Canadian Beaufort Sea between Herschel Island and Amundsen Gulf during summer (Moore and Reeves, 1993:319). Whales begin moving back westward between late August and early October (Richardson et al., 1987:469-471; Miller et al., 1996:18; I. Akootchook in USDOI, MMS, 1995:12). The fall migration, extending into late October some years (Moore and Clarke, 1992:29), also seems to occur in pulses, although the pattern is not as clear as in the spring migration (Ljungblad et al., 1987:53-54; Treacy, 1988:39, 1989:15-35, 1990:13-35; Moore and Reeves, 1993:342). These pulses may constitute age segregations with smaller whales migrating earlier, followed by larger adults and females with young. The first pulse has been observed to consist of hundreds of bowheads in schools like fish (T. Napageak - Pers. Comm., Nuiqsut Whaling Captains Meeting, August 13, 1996:23). These whales are not accompanied by calves (J. Tukle in USDOI, MMS, 1986:21). The second pulse is thought to consist of females with calves (J. Tukle in USDOI, MMS, 1986:20; T. Napageak - Pers. Comm., Nuiqsut Whaling Captains Meeting, August 13, 1996:22). Fall migration generally occurs south of the pack ice and closer inshore than the spring migration (Moore and Reeves, 1993:342). Bowhead whales apparently take their time returning westward during the fall migration, sometimes barely moving at all, with some localities being used as staging areas due to abundant food resources or for social reasons (W. Bodfish in NSB, 1981:296; S. Akootchook in USDOI, MMS, 1995:18).

Fall surveys show that the median water depth at bowhead whale sightings (1982-1995) between 141°W to 146°W longitudes is 138 ft (42 m) (Treacy, 1991:53, 1992:55, 1994:65, 1996:55). During fall migration, whales are found close inshore east of Barter Island and from Cape Halkett to Point Barrow (Moore and Reeves, 1993:335), generally in water depths less than 164 ft (50 m) (Treacy, 1991:49-53; 1992:55; 1994:65). Bowheads take about 2 days to travel from Kaktovik to Cross Island, reaching the Prudhoe Bay area by late September (T. Napageak - Pers. Comm., Nuiqsut Whaling Captains Meeting, August 13, 1996:23; A. Oenga in NSB, 1980:182). From Cross Island it takes the whales another 5 days to reach Point Barrow (T. Napageak - Pers. Comm., Nuiqsut Whaling Captains Meeting, August 13, 1996:22). Inupiat believe that whales follow the ocean currents carrying food organisms. If the currents go close to Cross Island, whales migrate near there (T. Napageak - Pers. Comm., Nuiqsut Whaling Captains Meeting, August 13, 1996:13). In the region immediately east of the project area, bowheads reportedly travel on the inshore side of Cross Island (V. Nageak in Shapiro and Metzner, 1979:A-II-23).

Whales have also been reported inside the barrier islands near Cross Island practically every year and have been observed between Seal Island and West Dock (F. Long, Jr. - Pers. Comm., Nuiqsut Whaling Captains Meeting, August 13, 1996:14-15). During years when fall storms push ice up against the barrier islands in the Beaufort Sea, bowheads may migrate on the shoreward (lagoon) side of Cross Island, the Midway Islands, and No Name Island. Also, crews looked for whales inside the barrier islands during the years of commercial whaling (T. Brower, Sr., in NSB, 1980:107). However, aerial surveys from 1980 to 1995 have not documented that bowheads migrate inshore of Cross Island (Miller et al., 1996:3-12).

Bowhead whales may swim very close to shore on some occasions (Rexford, 1996; I. Akootchook in USDOI, MMS, 1979:6). Bowheads have been observed feeding not more than 1,500 ft (457 m) offshore in about 15 to 20 ft (4.6 to 6 m) of water (A. Brower in USDOI, MMS, 1979:6; H. Rexford in USDOI, MMS, 1979:16). Smaller whales may swim in water depths of 14 to 18 ft (4.3 to 5.5 m) (T. Brower in NSB, 1980:107). Inupiat whaling crews have noticed that whale migration appears to be influenced by wind patterns, moving when winds start up and stopping when they are slow (P. Tukle in USDOI, MMS, 1986:24). From Point Barrow, whales migrate back southward through the Chukchi Sea to wintering grounds in the Bering Sea (Moore and Clarke, 1992:31-32).

Fall surveys conducted in the Northstar project area (near Cross Island) from 1979 through 1995 recorded the occurrence of bowheads from the barrier islands to about 75 miles (120 km) offshore, with most sighted 6.2 to 37.2 miles (10 to 60 km) offshore in water depths of 33 to 328 ft (10 to 100 m) (Miller et al., 1996:14-33). In general, bowhead whales seemed to migrate closer to shore in light ice years and farther offshore in heavy ice years, with distributions peaking at 19 to 25 miles (30 to 40 km) and 37 to 43.5 miles (60 to 70 km), respectively (Miller et al., 1996:35). From 1979 to 1986, Ljungblad et al., (1987:136-137) observed that fall migration extended over a longer period, and sighting rates were larger and peaked later in the season in years of light ice cover compared to years of heavy ice cover (Moore and Reeves, 1993:342).

It is difficult to survey spring-migrating bowhead whales effectively, because usually no well defined lead system is present east of the Colville River (Moore and Reeves, 1993:319). Therefore, only occasional observations of bowhead whales have been made during spring, usually in small cracks or holes (Moore and Reeves, 1993:317). However, the spring lead system is generally north of the Liberty project area.

In contrast, fall migration routes in the Beaufort Sea have been reasonably well documented. Aerial surveys conducted by MMS across the Beaufort Sea during fall migration suggest that bowhead whales only seldom migrate through or near the project area. Inupiat whalers question the results of aerial censuses of bowhead whales conducted by MMS in the Beaufort Sea. For example, whaling crews sighted 23 bowheads in the Kaktovik region during the fall of 1983 in contrast to 5 whales sighted by MMS aircraft (J. George in USDO, MMS, 1983:58-59).

Little is known regarding age at sexual maturity or mating behavior and timing for bowheads. It is assumed that mating takes place in late winter and spring (Koski et al., 1993:248), perhaps continuing through the spring migration (Koski et al., 1993:228). Most calves are born from April through early June during the spring migration, with a few calves born as early as March and as late as August (Koski et al., 1993:250). Calves are about 13 to 15 ft (4 to 4.5 m) at birth and reach 42 to 66 ft (13 to 20 m) as adults. Females produce a single calf, probably every 3 to 4 years (Koski et al., 1993:254).

Bowheads are filter-feeders, sieving prey from the water by means of baleen fibers in their mouth. They feed almost exclusively on zooplankton from the water column, with primary prey consisting of copepods (54%) and euphausiids (42%), as indicated from stomach analyses of whales taken in the Alaskan Beaufort Sea (Lowry, 1993:201-238). Other prey include mysids, hyperiid and gammarid amphipods, other pelagic invertebrates, and small fish. Bowheads feed heavily in the Canadian Beaufort Sea and Amundsen Gulf area during summer and fall migration through the Alaskan Beaufort Sea (Alaska Clean Seas, 1983:27; Ljungblad et al., 1987:53; Lowry, 1993:222). In surveys conducted from 1979 through 1987, concentrations of feeding bowheads were observed east of Point Barrow and just north of Harrison Bay (Ljungblad et al., 1987:53). Observations of feeding bowheads in 1998 found the whales feed primarily along the Alaskan coast near Kaktovik, but that feeding locations vary among years (Richardson and Thomson, 1999). Most feeding observed during studies in the eastern Beaufort Sea occurred over the continental shelf, often in the inner shelf (ibid). However, a study on the importance of the eastern Beaufort Sea to feeding Bowhead whales indicated that, for this stock, food resources consumed there did not contribute significantly to the whales' annual energy needs (Richardson, 1987). The Science Advisory Committee of the North Slope Borough found numerous and significant deficiencies in this study, and rejected the finding that the study area was unimportant as a feeding area for bowhead whales. Additional research on the importance of the eastern Beaufort as feeding habitat is currently being done by the Minerals Management Service. Carbon isotope analysis of bowhead baleen has indicated that a significant amount of feeding may occur in wintering areas of the Chukchi and Bering Seas (Schell et al., 1987; Schell, 1998). The barrier islands all along the Beaufort Sea coast are considered by local residents an

important resource to the bowhead whale for use as staging and feeding areas (M. Pederson in USACE, 1996:51).

The summer distribution of bowheads within the Beaufort Sea is determined primarily by prey density and distribution, which in turn are responsive to variable current and upwelling patterns (LGL and Greene ridge, 1987:2-3). Sub-adult bowheads were observed to feed in water depths less than 164 ft (50 m) in the Canadian Beaufort Sea (Richardson et al., 1987:468-469). However, little is known about adult feeding behavior in the Canadian Beaufort.

Bowheads have extremely sensitive hearing. For example, they are capable of detecting sounds of icebreaker operations at a range of up to 31 miles (50 km) (Richardson, 1996:108). It has been suggested that such sensitive hearing also allows whales to use reverberations from their low frequency calls to navigate under the pack ice and to locate open water polynyas where they surface (Ellison et al., 1987:332). Bowheads exhibit avoidance behavior at many manmade sounds, but there is still considerable debate regarding their range of sound detection (Richardson et al., 1995a:263). It is well known among Inupiat hunters that bowhead whales are extremely sensitive to noise (H. Rexford in USDOI, MMS, 1979:13; R. Ahkivgak in NSB, 1980:103; H. Ahsogeak in NSB, 1980:104; T. Brower in NSB, 1980:107; H. Brower in USDOI, MMS, 1990:10). Communications among whales during migration and in response to danger also has been observed to alter migration patterns (A. Brower in USDOI, MMS, 1986:49; T. Napageak in USDOI, MMS, 1995:13). Whaling crews have observed that disturbances to migration as a result of a strike are temporary (J.C. George in USACE, 1996:64).

Generally, the vocalizations of bowhead whales are low, less than 400 hertz (Hz) frequency-modulated calls; however, their call repertoire also includes a rich assortment of amplitude-modulated and pulsed calls with energy up to at least 5 kilohertz (Wursig and Clark, 1993:176). Calls and songs have been suggested to be associated with different contexts and whale behavior. Observations have been made that support the theory that calls are used to maintain social cohesion of groups. For instance, loud frequency-modulated calls were heard as a mother and a calf rejoined after becoming separated during summer feeding (Wursig and Clark, 1993:189). Once the two were together again, calling stopped (Wursig and Clark, 1993:189). During spring migration off Point Barrow, there have been several instances when individual whales repeatedly produced calls with similar acoustic characteristics (Clark et al., 1987:345). Bowhead whales have been noted to produce signature calls lasting for 3 to 5 minutes each and continuing up to 5 hours (Wursig and Clark, 1993:189). Different whales produce signature calls as they counter call with other members of their herd. It has been suggested that calling among bowhead whales may aid in migration of the herd and that the surface reverberation of the sound off the ice may allow these whales to discriminate among areas through which they can and cannot migrate (Ellison et al., 1987; Wursig and Clark, 1993:190).

It has been speculated that bowheads are able to locate leads and open water along the marginal ice zone in winter by using acoustics (Moore and Reeves, 1993:353). Although bowheads are morphologically adapted to their ice-dominated environment and can break

holes in the ice to breathe, they may use vocalization to assess ice conditions in their path. For example, the intensity of reflected calls is as much as 20 decibels (dB) higher from ice floes with deeper keels than from relatively flat, thin ice (Ellison et al., 1987:329). Bowheads may use such differences in intensity of reflected calls to differentiate between deep keel ice floes and flat, thin ice.

Bowhead whales have no known predators in the Bering Sea, except perhaps killer whales (*Orcinus orca*). Such attacks in the Bering Sea have occurred, but their frequency is reported as low. The frequency of attacks by killer whales in the Beaufort Sea is not well documented (George et al., 1994). Little is known about naturally occurring disease and death among bowhead whales. While certain viral agents are present in this stock, it is unknown how much they may contribute to natural mortality or reduced reproduction (Philo et al., 1993).

Bowheads are harvested by Inupiat in the Alaskan Beaufort, Bering, and Chukchi Seas. The total Alaskan subsistence harvest of bowheads between 1978 and 1991 ranged from 8 in 1982 to 30 in 1990, averaging 18 per year. From 1991 to 1995, a combined average of 19.4 bowhead whales per year were taken by the communities of Barrow, Nuiqsut, and Kaktovik (USDOL, MMS, 1996:Table III.C.3-4). The combined spring and fall harvest for 1998 was 41 whales landed and 12 struck and lost. In addition to the subsistence harvest, other man-induced impacts may contribute to morbidity and mortality. Commercial fishing occurs in the Bering Sea and elsewhere within the range of this stock. Interaction with fishing gear is rare, however whales with ropes caught in their baleen and with scarring caused by rope entanglement have been reported (Philo et al., 1993; NMML, unpubl. data). No incidental takes of bowheads have occurred in U.S. waters (Small and DeMaster, 1995). George et al., (1994) report three documented ship strike injuries observed among 236 bowheads taken in subsistence hunts. Man made noise in the marine environment is increasing with industrialization of the Alaskan arctic, and may impact these whales to an unknown degree. Presently there is insufficient evidence about cumulative and long-term effects of anthropogenic noises (Richardson and Malme, 1993). Exposure to oil spills may have direct adverse consequences to bowheads, or predispose some whales to infection or injury.

III. Environmental Baseline

The environmental baseline considers the status and habitat of a species within the action area. The occurrence, numbers, and habitat use of the bowhead whale within the Alaskan Beaufort Sea (the action area) has been described in the previous section. This section will provide an analysis of the effects of past and ongoing human and natural factors leading to the current status of the species, its habitat (including any designated critical habitat), and ecosystem, within the action area.

Aerial surveys near the Liberty project site in 1997 (BPXA, 1998) showed that the primary fall migration route was offshore of the barrier islands, outside the development area. However, a few bowheads were observed in lagoon entrances between the barrier islands and in the lagoons immediately inside the barrier islands. Because survey coverage in the nearshore areas was more intensive than in offshore areas, maps and

tabulations of raw sightings may overestimate the number of whales seen in nearshore areas relative to offshore areas. Nevertheless, these data provide information on the presence of bowhead whales near Liberty during the fall migration. A review of MMS bowhead aerial survey data for 1987-1999 found that effort had not observed bowhead whales in the Liberty project area; most sightings in the general locale being outside the barrier islands. From these data, few whales would be expected to be found within 10 kilometers (6 miles) of the proposed Liberty Island location.

There are several anthropogenic factors which may affect the bowhead whale within the action area. These include oil and gas exploration and/or production activity within Federal and State of Alaska waters and along the Alaskan North Slope, shipping and vessel traffic, and Inupiat subsistence hunting.

The Northstar Project is an offshore field in that includes both Federal and State of Alaska leases. The Northstar reservoir contains an estimated 260 million barrels of oil and has an estimated operational life of 15 years. A Final EIS has been completed for the Northstar Project, the second offshore field scheduled for development and production in the Beaufort Sea. Construction activities for Northstar began during the 1999-2000 winter season. Northstar is being developed on a gravel island as a self-contained development/ production facility, similar to Liberty. The gravel production island was constructed during the winter in 39 feet of water on the remains of Seal Island, which is on a State lease about 6 miles offshore of Point Storkersen. A buried pipeline between Northstar and Point Storkersen was constructed during the winter from ice roads. BPXA intends to drill 15 production wells, 7 injection wells, and 1 disposal well initially, with 14 additional well slots to allow for reservoir uncertainties. Additional information about Northstar can be found in the Final EIS, which is incorporated here by reference (USACE, 1999). Most-probable estimates of the annual level of incidental take of bowhead whales due to the Northstar project are 173 whales, with a maximum of 1,533 (FR 34014, May 25, 2000). These takes would be by harassment due to noise, and are described in the NMFS's Biological Opinion for that action (USDOC, 1999).

The Endicott project, in Prudhoe Bay, is the first offshore production facility developed in the Beaufort Sea. Endicott has been producing oil since 1987. Endicott is located on a manmade gravel structure inside the barrier islands in relatively shallow water. Support traffic is over a gravel causeway that also contains the pipeline to shore. There are no estimates of potential takes of bowhead whales due to noise from this facility, nor are there data on the noise levels Endicott may introduce into the Beaufort Sea.

Marine-based geophysical exploration occurs in the Beaufort Sea during ice-free periods, normally from July to October. High energy and low energy (resolution) seismic studies occur. Low-resolution seismic, such as on-bottom cable (OBC) or 3-D employs a towed array of airguns which fire bursts of compressed air downwards in short, discontinuous pulses. Cables containing hydrophones are placed on the seafloor and detect reflected pulses which indicate underlying strata. Seismic exploration using OBC technologies has occurred annually in the Beaufort since 1996. Monitoring studies of 3-D seismic exploration (6-18 airguns totaling 560-1500 cubic inches) in the nearshore Beaufort Sea during 1996-1998 have demonstrated that nearly all bowhead whales will avoid an area

within 20 km of an active seismic source, while deflection may begin at distances up to 35 km. Sound levels received by bowhead whales at 20 km ranged from 117-135 dB re 1 μ Pa rms and 107-126 dB re 1 μ Pa at 30 km. The received sound levels at 20-30 km are considerably lower than have previously been shown to elicit avoidance in bowhead or other baleen whales exposed to seismic pulses. As many as 800 bowheads may have migrated within 20 n. mi. of the seismic operation in 1997, and may have been exposed to seismic sounds. Inupiat whalers have observed the effects of seismic on bowhead whales for years, and have testified that whales begin to deflect from normal migratory paths at distances of 35 miles from an active seismic operation, and are displaced from their normal migratory path by as much as 30 miles (USDOL, MMS, 1997). Currently, only a single geophysical seismic program is conducted in the Beaufort during the open water period. The NMFS has authorized this activity to incidentally take bowhead whales, by harassment due to noise. NMFS estimates this OBC program may take 1,300 bowheads annually, based on the 20 km criterion. This is the most probable estimate of take, while the maximum estimate would be 2,630.

NMFS has also received application for a small take authorization concerning a shallow hazards survey in the Beaufort Sea during the 2001 open water season. This survey is associated with route alternative selection for a proposed gas pipeline between Alaska and the lower 48 states. The work would employ two source vessels working between Prudhoe Bay and the Canadian McKenzie. The vessels would use low power, high frequency equipment to characterize the sediments along the route. Most of this work should occur at times when bowhead whales are not present in the U.S. Beaufort Sea, although work in Canadian waters will occur during periods of summer residency by bowheads. The work may be detectable to bowhead whales, and NMFS estimates the most probable level of annual take as 285 whales (20 km criterion), with a maximum take estimated at 1,601.

The State of Alaska is currently leasing State lands for oil and gas exploration and production. There has been one State sale in the Beaufort Sea (Sale 86 Central in 1997), while three area wide sales are planned for 1999 through 2001.

The Marine Mammal Protection Act and Endangered Species Act provide an exemption to Alaskan Natives for the subsistence harvest of bowhead whales. Bowheads are taken in the northern Bering Sea and in the Chukchi Sea during their northern migration, and in the Beaufort Sea during their return in the fall. The harvest quota for this hunt is established by the International Whaling Commission (IWC), and is currently set at 67 strikes per year through 202, with a 5-year block quota numbering 280 animals. The number of whales actually struck each year varies, with 1995, 1996, and 1997 totals of 57, 44, and 60 whales, respectively. The IWC's Scientific Committee determined a limit of 75 bowhead strikes per year would allow the population to increase at a rate of 1.46 per cent, or 120 animals. While struck and lost animals are considered as mortalities under quota, evidence exists of whales surviving strikes. Additionally, the Alaska Eskimo Whaling Commission reports strike efficiency has improved in recent years (Suydam et al., 1997).

IV. Effects of the Proposed Action on Bowhead Whales

Development and Production activities associated with offshore oil and gas activities on the Alaska OCS may create the potential for some disturbance and harassment of endangered bowhead whales. Those activities associated with the offshore development and production of the Liberty project in the Beaufort Sea include the expected production of noise from construction, drilling, and use of aircraft and support vessels. Although not expected, the development and production of the Liberty project could result in an accidental oil spill. This section examines these activities, and assesses their potential to adversely effect endangered bowhead whales.

A. Potential effects associated with Noise and Disturbance

There is concern that manmade noise affects bowheads by raising background noise levels, which could interfere with detection of sounds from other bowheads or from important natural sources, or by causing disturbance reactions, which could cause the migration route to be displaced farther from shore.

Sound is transmitted efficiently through water. Hydrophones often detect underwater sounds created by ships and other human activities many kilometers away, far beyond the distances where human activities are detectable by senses other than hearing. Sound transmission from noise-producing sources is affected by a variety of things, including water depth, salinity, temperature, frequency composition of the sound, ice cover, bottom type, and bottom contour. In general terms, sound travels farther in deep water than it does in shallow water. Sound transmission in shallow water is highly variable, because it is strongly influenced by the acoustic properties of the bottom material, bottom roughness, and surface conditions. Ice cover also affects sound propagation. Smooth annual ice cover may enhance sound propagation compared to open-water conditions. However, as ice cracks and roughness increases, sound transmission generally becomes poorer than in open water of equivalent depth. The roughness of the under-ice surface becomes more significant than bottom properties in influencing sound-transmission loss (Richardson and Malme, 1993).

Marine mammals use calls to communicate and probably listen to natural sounds to obtain information important for detection of open water, navigation, and predator avoidance. Baleen whale hearing has not been studied directly. There are no specific data on sensitivity, frequency or intensity discrimination, or localization (Richardson et al., 1995). For each species, the frequency range of reasonably acute hearing in baleen whales likely includes the frequency range of their calls. Most baleen whale sounds are concentrated at frequencies less than 1 kilohertz, but sounds up to 8 kilohertz are not uncommon (Richardson et al., 1995). Most calls emitted by bowheads are in the frequency range of 50-400 Hertz, with a few extending to 1,200 Hertz. The frequency range in songs can approach 4000 Hertz (Richardson et al., 1995). Based on indirect evidence, at least some baleen whales are quite sensitive to frequencies below 1 kilohertz but can hear sounds up to a considerably higher but unknown frequency. Most of the manmade sounds that elicited reactions by baleen whales were at frequencies below 1

kilohertz (Richardson et al., 1995). Some or all baleen whales may hear sounds at frequencies well below those detectable by humans. Even if the range of sensitive hearing does not extend below 20-50 Hertz, whales may hear strong infrasounds at considerably lower frequencies. Based on work with other marine mammals, if hearing sensitivity is good at 50 Hertz, strong infrasounds at 5 Hertz might be detected (Richardson et al., 1995).

There also is speculation that, under some conditions, extremely loud noise might cause temporary or permanent hearing impairment of bowheads (Kryter, 1985, as cited in Richardson and Malme, 1993). According to Richardson and Malme (1993), there is no evidence that noise from routine human activities (aside from explosions) would permanently cause negative effects to a marine mammal's ability to hear calls and other natural sounds. Given their mobility and avoidance reactions, it is unlikely that whales would remain close to a noise source for long. Also, baleen whales themselves often emit calls with source levels near 170-180 decibels re 1 microPascal (dB re 1 μ Pa) comparable to those from many industrial operations. It is unknown whether noise pulses from nonexplosive seismic sources, which can be much higher than 170-180 decibels, are physically injurious at any distance. The avoidance reactions of bowheads to approaching seismic vessels normally would prevent exposure to potentially injurious noise pulses.

The zone of audibility is the area within which a marine mammal can hear the noise. The ability of a mammal to hear the sound, such as from seismic operations, depends upon its hearing threshold in the relevant frequency band and the level of ambient noise in that band. The radius of the zone of audibility also depends upon the effective source level of the seismic pulse for horizontal propagation and on the propagation loss between the source and the potential receiver. The zone of responsiveness around a noise source is the area within which the animal would react to the noise. This zone generally is much smaller than the zone of audibility. The distance at which reactions to a particular noise become evident varies widely, even for a given species. A small percentage of the animals may react at a long distance, the majority may not react unless the noise source is closer, and a small percentage may not react until the noise source is even closer still. The activity of a whale seems to affect how a whale will react. In baleen whales, single whales that were resting quietly seemed more likely to be disturbed by human activities than were groups of whales engaged in active feeding, social interactions, or mating (Richardson et al., 1995). Habitat or physical environment of the animal also can be important. Bowhead whales whose movements are partly restricted by shallow water or a shoreline sometimes seem more responsive to noise (Richardson et al., 1995).

There is little information regarding visual or olfactory effects to bowhead whales. Richardson et al., (1995) stated that Inupiat whalers hunting from the ice-edge find that bowhead whales are alarmed by the sight or sound of humans or human activities (Carroll and Smithhisler, 1980, as reported in Richardson et al., 1995). They also commented that gray whales probably would react to visual cues as well as sound when very close to an actual industrial site, indicating that bowheads may react similarly. Based on this information, we believe it is unlikely that bowheads' olfactory or visual senses would be affected by activities associated with the Liberty project, considering

that its location is shoreward of the barrier islands, well removed from the bowhead migration route, and the fall migration route is through a relatively open Beaufort Sea compared to a fairly confined lead system during the spring migration.

1. Potential effects of noise associated with from Drilling Activities

Although underwater sounds from drilling on some artificial islands and caissons have been measured, we have little information about reactions of bowheads to drilling from these structures. Underwater noise levels from drilling operations on natural barrier islands or artificial islands are low and are not audible beyond a few kilometers (Richardson et al., 1995). Noise is transmitted very poorly from the drill rig machinery through land into the water. Even under open-water conditions, drilling sounds are not detectable very far from the structure. Noise associated with drilling activities varies considerably with ongoing operations. The highest documented levels were transient pulses from hammering to install conductor pipe. Stationary sources of offshore noise (such as drilling units) appear less disruptive to bowhead whales than moving sound sources (such as vessels). Some bowheads in the vicinity would be expected to respond to noise from drilling units by slightly changing their migration speed and swimming direction to avoid closely approaching these noise sources. Miles et al., (1987) predicted that the zone of responsiveness of bowhead whales to continuous noise sources from drilling from an artificial-island drilling site where roughly half of the bowheads are expected to respond to noise is a radius of 0.02-0.2 kilometers (0.012-0.12 miles) when the signal-to-noise ratio (S:N) is 30 decibels. (The S:N is the ratio of industrial noise to ambient noise. In this example, the industrial noise is drilling at an artificial island). A smaller proportion would react when the S:N is about 20 decibels (at a greater distance from the source), and a few may react at an S:N ratio even lower or at a greater distance from the source. By comparison, the authors predicted that roughly half of the bowheads are expected to respond at a distance of 1-4 kilometers (0.62-2.5 miles) from a drillship drilling when the S:N is 30 decibels.

Richardson and Malme (1993) point out that the data, although limited, suggest that bowheads react less dramatically to stationary industrial activities producing continuous noise, such as stationary drillships, than to moving sources, particularly ships. Most observations of bowheads tolerating noise from stationary operations are based on opportunistic sightings of whales near ongoing oil-industry operations, and it is not known whether more whales would have been present without those operations.

In Canada, bowhead use of the main area of oil-industry operations within the bowhead range was low after the first few years of intensive offshore oil exploration (Richardson, Wells, and Wursig, 1985), suggesting perhaps cumulative effects from repeated disturbance may have caused the whales to leave the area. In the absence of systematic data on bowhead summer distribution until several years after intensive industry operations began, it is arguable whether the changes in distribution in the early 1980's were greater than natural annual variations in distribution, such as responding to changes in the location of food sources. Ward and Pessah (1988) concluded that the available information from 1976-1985 and the historical whaling information do not support the suggestion of a trend for decreasing use of the industrial zone by bowheads as a result of

oil and gas exploration activities. They concluded that the exclusion hypothesis is likely invalid.

The activity of a whale seems to affect how a whale will react. In baleen whales, single whales that were resting quietly seemed more likely to be disturbed by human activities than were groups of whales engaged in active feeding, social interactions, or mating (Richardson et al., 1995). Migrating bowhead whales in the fall may be slightly more responsive to noise from drilling operations than summering bowheads. This may be due in part to greater variability of noise from the drill site in the fall, including variable activities of icebreakers and other support vessels. Habitat or physical environment of the animal also can be important. Bowhead whales whose movements are partly restricted by shallow water or a shoreline sometimes seem more responsive to noise (Richardson et al., 1995).

Greene (1997) measured underwater sounds under the ice at Liberty from drilling operations on Tern Island in Foggy Island Bay (approximately 2.4 kilometers east of the proposed location of Liberty Island) in February 1997. Sounds from the drill rig were generally masked by ambient noise at distances near 2 kilometers. The strongest tones were at frequencies below 170 hertz, but the received levels diminished rapidly with increasing distance and dropped below the ambient noise level at ranges of about 2 kilometers. Drilling sounds were not evident at frequencies above 400 hertz, even at distances as close as 200 meters from the drill rig.

Greene noted that if production proceeds at Liberty, the types and frequency characteristics of some of the resulting sounds would be similar to those from the drilling equipment in this study. Electric power generation, pumps, and auxiliary machinery again would be involved, as would a drill rig during the early stages of production. However, the production island also would include additional processing and pumping facilities. If the production equipment requires significantly more electric power, its generator sounds may be received at greater distances. These sounds would diminish rapidly with increasing distances due to high spreading losses (35 dB per tenfold change in range) plus the linear attenuation rates of 2-9 dB per kilometer (0.002-0.009 dB per meter). Sound transmission within the lagoon for activities at Liberty would be similar to the sound transmission measured for activities at Tern Island, but the barrier islands to the north and the lagoon's very shallow water near those islands should make underwater sound transmission very poor beyond the islands and into the Beaufort Sea.

Greene (1998) measured ambient noise and acoustic transmission loss underwater at Liberty Island in Foggy Island Bay during the open-water season of 1997 to complement transmission loss and ambient noise measurements made under the ice at Liberty in February 1997. The levels were consistent with other ambient noise measurements made in similar locations at similar times of the year. The measured ambient levels in winter generally were lower than those measured in summer, which means that industrial sounds would be expected to be detectable at greater distances during the winter. Bowheads are not present in the winter.

Richardson et al., (1995) summarized that noise associated with drilling activities varies considerably with ongoing operations. The highest documented levels were transient pulses from hammering to install conductor pipe. Underwater noise associated with drilling from natural barrier islands or manmade islands is generally weak and is inaudible at ranges beyond a few kilometers. Richardson et al., (1995) estimated that drilling noise generally would be confined to low frequencies and would be audible at a range of 10 kilometers only during unusually quiet periods, while the audible range under more typical conditions would be approximately 2 kilometers.

Because the bowhead whale migration corridor is 10 kilometers or more seaward of the barrier islands, we do not expect that drilling and production noise from the Liberty project will reach most of the migrating bowhead whales (BPXA, 1998). In the general Prudhoe Bay area, the southern edge of the main migration route is about 20 kilometers offshore for bowheads (Moore and Reeves, 1993; Miller et al., 1997; BPXA, 1998), although some whales do migrate closer to the barrier islands. The closest reported sighting of a bowhead whale in one of the lagoon entrances or inside the barrier island was more than 10 kilometers from the proposed Liberty site, beyond the distance that noise is likely to be audible (Davis et al., 1985; Johnson et al., 1986; Greene, 1997, 1998). Based on this information, we anticipate that few, if any, bowhead whales will be present near Liberty Island due to its location and the water depth. It is unlikely that the few individual bowhead whales which may detect noise associated with the drilling activities will respond in a way that will affect their ability to successfully maintain essential behaviors.

2. Potential Effects of Noise and Disturbance from Vessel Traffic

Vessel traffic could affect bowhead whales. According to Richardson and Malme (1993), most bowheads begin to rapidly swim away when vessels approach rapidly and directly. Avoidance usually begins when a rapidly approaching vessel is 1-4 kilometers (0.62-2.5 miles) away. In one instance, seven interaction incidents between bowhead whales and vessels were observed from a circling aircraft. The vessels ranged from a 13-meter diesel-powered fishing boat to small ships. A few whales may react at distances from 5-7 kilometers (3-4 miles), and a few whales may not react until the vessel is less than 1 kilometer (less than 0.62 miles) away (Richardson and Malme, 1993). Received noise levels as low as 84 decibels re 1 μ Pa or 6 decibels above ambient noise may elicit strong avoidance of an approaching vessel at a distance of 4 kilometers (2.5 miles) (Richardson and Malme, 1993).

In the Canadian Beaufort Sea, bowheads observed in vessel-disturbance experiments began to orient away from an oncoming vessel at a range of 2-4 kilometers (1.2-2.5 miles) and to move away at increased speeds when approached closer than 2 kilometers (1.2 miles) (Richardson and Malme, 1993). Vessel disturbance under experimental conditions caused a temporary disruption of activities and sometimes disrupted social groups, when groups of whales scattered as a vessel approached. Reactions to slow-moving vessels, especially if they do not approach directly, are much less dramatic. Bowheads are often more tolerant of vessels moving slowly or in directions other than

toward the whales. Fleeing from a vessel generally stopped within minutes after the vessel passed, but scattering may persist for a longer period.

Observations made in the central Beaufort Sea during the fall were similar. Koski and Johnson (1987) reported that bowheads 1-2 kilometers to the side of the track of an approaching oil-industry supply vessel swam rapidly away to a distance of 4-6 kilometers from the vessel's track. After some disturbance incidents, at least some bowheads return to their original locations (Richardson and Malme, 1993). Koski and Johnson (1987) reported some individually recognizable bowheads returned to feeding locations within 1 day after being displaced by boats. Whether they would return after repeated disturbances is not known. Some whales may exhibit subtle changes in their surfacing and blow cycles, while others appear to be unaffected. Bowheads actively engaged in social interactions or mating may be less responsive to vessels. Bowheads that are actively migrating may react differently than bowheads that are engaged in feeding or socializing.

There will be annual marine-vessel traffic transporting supplies between Prudhoe Bay or Endicott and Liberty during the open-water season from July through September. This vessel traffic likely will occur shoreward of the barrier islands between Prudhoe Bay or Endicott and Liberty Island and is not likely to affect bowhead whales. An estimated 150 local round trips by marine vessels could occur during the summer construction period. An estimated four to five trips per year by marine vessels could occur during the drilling and production period. Vessel traffic outside the barrier islands is likely to be minimal. The process modules and permanent living quarters would be transported to the site on seagoing barges during the open-water season, after the island is constructed. Two sealifts are planned. Infrastructure would be sealifted to the island in Year 2 and process modules in Year 3. This barge traffic is likely to be part of the sealift and probably would be the only vessel traffic associated with the project that will occur outside the barrier islands east of Prudhoe Bay. Movement of these barges around Point Barrow is limited to a short period from mid-August through mid- to late September. This barge traffic likely will remain shoreward of the barrier islands between Prudhoe Bay and Liberty Island and is not likely to affect bowhead whales. Unless severe ice conditions are encountered, the transport of equipment by barge should be completed prior to the bowhead whale migration. If the barge traffic continues during the whale migration, individual bowheads may be disturbed by vessel traffic as described above. Any disturbance is likely to be temporary and unlikely to result in more than minor *disruptions of any essential behaviors*. Non-emergency vessel traffic outside the barrier islands would be scheduled to avoid interference with subsistence whaling.

3. Potential Effects of Noise and Disturbance from Aircraft Traffic

Most offshore aircraft traffic in support of the oil industry involves turbine helicopters flying along straight lines. Underwater sounds from aircraft are transient. According to Richardson et al., (1995), the angle at which a line from the aircraft to the receiver intersects the water's surface is important. At angles greater than 13 degrees from the vertical, much of the incident sound is reflected and does not penetrate into the water. Therefore, strong underwater sounds are detectable for roughly the period of time the aircraft is within a 26-degree cone above the receiver. Usually, an aircraft can be heard in the air well before and after the brief period it passes overhead and is heard underwater.

Observations indicate that most bowheads are unlikely to react significantly to occasional single passes by low-flying helicopters ferrying personnel and equipment to offshore operations at altitudes above 150 meters (500 feet) (Richardson and Malme, 1993, as cited in USDOl, MMS, Alaska OCS Region, 1996a). At altitudes less than 150 meters (500 feet), some whales probably would dive quickly in response to the aircraft noise. Noise from aircraft generally is audible for only a brief time (tens of seconds) if the aircraft remains on a direct course, and the whales should resume their normal activities within minutes (Richardson et al., 1995). Patenaude et al., (1997) found that most reactions by bowheads to a Bell 212 helicopter occurred when the helicopter was at altitudes of 150 meters or less and lateral distances of 250 meters or less. A total of 64 bowhead groups were observed near an operating helicopter. Most (47 groups) were observed during a single helicopter overflight or within 2 minutes after landing or during takeoff (9 groups). Immediate dives occurred during 5 of 46 overflights, when the helicopter approached altitudes 150 meters or less. In one case at 150 meters or less, a bowhead breached three times, possibly in response to the helicopter, commencing 30 seconds after the helicopter passed at an altitude of 180 meters and a lateral distance of 1600 meters. Based on 52 bowhead observations at known lateral distances, reactions did not occur significantly more often when the helicopter was operating at a lateral distance of 250 meters or less. The most common reactions were abrupt dives and shortened surface time and most, if not all, reactions seemed brief. However, the majority of bowheads showed no obvious reaction to single passes, even at those distances. The helicopter sounds measured underwater at depths of 3 meters and 18 meters showed that sound consisted mainly of main rotor tones ahead of the aircraft and tail rotor sounds behind the aircraft; more sound pressure was received at 3 meters than at 18 meters; and peak sound levels received underwater diminished with increasing aircraft altitude.

Year-round helicopter access is planned for the Liberty Project, weather permitting. During the construction phase, there may be an average of 10-20 flights per day during the first year. An estimated three helicopter trips per week would be required to transport personnel during drilling and production operations except during breakup, when there would be one flight per day. Aircraft traffic would be limited to the area between Prudhoe Bay and Liberty Island, well south of the migration corridor and inside the barrier islands. Helicopters will fly at an altitude of at least 1,500 feet, except for

takeoffs, landings, and adverse weather conditions. Because of these factors, we would not expect this helicopter traffic to significantly affect bowhead whales.

The only fixed-wing aircraft proposed for this project would be for pipeline surveillance. Fixed-wing aircraft overflights at low altitude (300 meters or less [1,000 feet]) often cause hasty dives. Reactions to circling aircraft are sometimes conspicuous if the aircraft is below an altitude of 300 meters (1,000 feet), uncommon at 460 meters (1,500 feet), and generally undetectable at 600 meters (2,000 feet). Repeated low-altitude overflights at 150 meters (500 feet) during aerial photogrammetry studies of feeding bowheads sometimes caused abrupt turns and hasty dives (Richardson and Malme, 1993). Aircraft on a direct course usually produce audible noise for only tens of seconds, and the whales should resume their normal activities within minutes (Richardson and Malme, 1993). Patenaude et al., (1997) found that few bowheads (2.2%) were observed to react to Twin Otter overflights at altitudes of 60-460 meters. During the four spring seasons, 11 bowhead whale groups were observed to react overtly to a Twin Otter. Reactions consisted of two immediate dives, one unusual turn, and eight brief surfacings, representing 2.2 % of the bowhead groups (507 groups) sighted from the aircraft. Most observed reactions by bowheads occurred when the Twin Otter was at altitudes of 182 meters or less and lateral distances of 250 meters or less. Eight groups out of 218 groups reacted to the Twin Otter at altitudes of 182 meters or less. There was little, if any, reaction by bowheads when the aircraft circled at an altitude of 460 meters and a radius of 1 kilometer. These data suggest that any effects from disturbance by aircraft associated with the Liberty project will be brief, and the whales should resume their normal activities within minutes. As with helicopters, this traffic would be well south of the migration corridor and not expected to result in more than minor disturbances to individual bowhead whales.

4. Potential Effects of Noise and Disturbance from Construction Activities

Island and pipeline construction activities, including placement of fill material, installation of sheetpile, trenching for the pipeline, and pipelaying, would cause noise that could disturb bowhead whales. Placement of fill material and slope protection materials for island construction will occur during the winter months, when bowhead whales are not present. Some minor adjustments to side slope protection may occur during the open-water season before operations start. These activities would generally be completed by mid-August, before the bowhead whale migration. Placement of sheetpile would generate noise during the open-water period for one construction season but should be completed in early to mid-August, before the whales migrate. Even if these activities are ongoing during the migration, noise produced is expected to be minor and is not expected to affect bowhead whales, because the island is well shoreward of the barrier islands and whales infrequently go there. Offshore pipeline-construction activities between the production island and onshore facilities also would be constructed during the winter and are not likely to affect whales. Bowhead whales are not likely to be affected by placing fill for island construction, island reshaping before placing slope-protection material, or pipeline trenching or backfilling, or the sediment or turbidity as a result of those activities.

Recently, construction noise was measured at Seal Island for the Northstar project (Blackwell and Greene, 2001). Activities included pile driving, generators, heavy equipment working on the island, aircraft (helicopters), and vessels. Nearly all the noises recorded from the island were at frequencies below 400Hz. Overall broadband levels of underwater sound from activities on or around Northstar ranged from 112 to 139 db re 1 μ Pa, at range of 1/4 nautical mile, from 92 to 121 db re 1 μ Pa at 1 n.mi., and from 92 to 113 db re 1 μ Pa at 5 n. mi. Received levels were variable, and reached their highest levels of 135-139 db re 1 μ Pa at a distance of 451 meters from the island. Broadband received levels of underwater noise were at least 11 dB above ambient levels (98 dB db re 1 μ Pa) at a range of 5 n. mi. on one day. Island noise degraded to ambient within 10 n.mi. of the island on one day during this study, and within 1 n.mi. during another day (no vessels operating). Some noises were detected out to a range of 15 n. mi. High levels of noise were correlated with the presence of a self-powered barge which was often pushing against the island due to the absence of mooring facilities.

Since most of these activities are not expected to occur during the migration season when whales are present, we believe that any noise and disturbance associated with the construction of the Liberty project is unlikely to be detected by bowhead whales. If these activities extend into the migration period, we do not anticipate that more than a few individual whales may detect these noises due to the infrequent occurrence of whales shoreward of the barrier islands where the Liberty project is located. Individual whales which may detect these noises are unlikely to experience more than minor disruptions to normal behaviors.

B. Potential Effects from an Accidental Oil Spill

A number of studies have attempted to model the probability that bowhead whales in the Beaufort Sea would contact oil in the event of a >1,000 barrel spill (Reed et al., 1987; Neff, 1990:49; Bratton et al., 1993:733). The models suggest that only a small number (0-2%) of the Beaufort Sea bowhead population would be affected by a large spill. One model calculated a probability of 51.8% that at least one bowhead whale could encounter oil should a spill occur in the Beaufort Sea OCS planning area. There was a 40% probability of 1-200 whales encountering oil if a spill occurred (Bratton et al., 1993:734). Whether or not bowhead whales would come into contact with oil would depend on the timing and magnitude of the spill, the presence or absence of shorefast and broken ice, and the effectiveness of the cleanup. Potential impacts of oil on bowheads are discussed below.

It is difficult to accurately predict the effects of oil on bowhead whales (or any cetacean) because of a lack of data on the metabolism of this species and because of inconclusive results of examinations of baleen whales found dead after major oil releases (Bratton et al., 1993:736; Geraci, 1990:167-169). Nevertheless, some generalizations can be made regarding impacts of oil on individual whales based on present knowledge. Oil spills that occurred while bowheads were present could result in skin contact with the oil, baleen fouling, ingestion of oil, respiratory distress from hydrocarbon vapors, contaminated food sources, and displacement from feeding areas (Geraci, 1990:181-192). Actual impacts

would depend on the extent and duration of contact, and the characteristics (age) of the oil (Albert, 1981:946). Bowhead whales could be affected through residual oil from a spill even if they were not present during the oil spill. Most likely, the effects of oil would be irritation to the respiratory membranes and absorption of hydrocarbons into the bloodstream (Geraci, 1990:184). If an oil spill were concentrated in open water leads, it is possible that a bowhead whale could inhale enough vapors from a fresh spill to affect its health. Inhalation of petroleum vapors can cause pneumonia in humans and animals due to large amounts of foreign material (vapors) entering the lungs (Lipscomb et al., 1994:269). It is unclear if vapor concentrations after an oil spill in the Arctic would reach levels where serious effects, such as pneumonia, would occur in bowhead whales. Although pneumonia was not found in sea otters that died after the *Exxon Valdez* oil spill, inhalation of vapors was suspected to have caused interstitial pulmonary emphysema (accumulation of bubbles of air within connective tissues of the lungs). Some northslope oil, such as Northstar crude, are light-weight with a relatively high evaporation rates, although rates of evaporation in the Arctic are decreased due to low temperatures (Engelhardt, 1987:104-106). Therefore, evaporation rates and exposure to oil may be an important factor to the impacts bowheads may experience from inhalation of vapors. Bratton et al., (1993:722) reviewed the available literature on potential impacts of hydrocarbons on whales and theorized that impacts on the respiratory system of a bowhead whale confined by ice to a small, oil-contaminated area would be limited to: "... irritation of the mucous membranes, .. irritation of the respiratory tract, and .. absorption of volatile hydrocarbons into the bloodstream through the bronchial tree with rapid excretion by the same route."

Whales may also contact oil as they surface to breathe, but the effects of oil contacting skin are largely speculative. Experiments in which *Tursiops* were exposed to petroleum products showed transient damage to epidermal cells, and that cetacean skin presents a formidable barrier to the toxic effects of petroleum (Bratton et al., 1993:720). Bowhead whales have an exceedingly thick epidermis (Haldiman et al., 1985:397). The skin of bowhead whales is characterized by hundreds of rough, skin lesion areas. "*These rough areas are variable in size and shape, often 1 to 2 inches in diameter and 1 to 3 mm deep with numerous 'hair-like' projections extending upward 1 to 3 mm from the depths of the damaged skin surface.*" (Albert, 1996:7). Blood vessels are located just beneath the epidermis of these skin lesions (Albert, 1981:947; Haldiman et al., 1985:391), and large numbers of potentially pathogenic (disease-causing) bacteria have been documented in these areas (Shotts et al., 1990:358). Many of these bacteria produce enzymes that are capable of causing tissue necrosis (tissue death) (Haldiman et al., 1985:397; Shotts et al., 1990:351). The ultrastructural nature of these areas of damaged epidermis has recently been documented (Henk and Mullan, 1996). The origin of these rough areas is unknown, but oil is likely to adhere at these sites. Haldiman et al., (1981:648) documented that Prudhoe Bay crude oil adheres to isolated preserved skin samples of bowhead whales and that, "*The amount of oil adhering to the surrounding skin and epidermal depression appeared to be directly proportional to the degree of 'roughness' of the [skin].*" The authors concluded that these results were, "*indicative of the possible adherence to the live skin of an active bowhead whale*". Geraci and St. Aubin's (1985) investigations found that exposure to petroleum did not make a cetacean vulnerable to disease by altering skin microflora or by removing inhibitory substances from the epidermison

several species of toothed whales, including *Tursiops* with superficial wounds of the epidermis, found only temporary effects which they described as secondary to the potential effects from inhalation and ingestion (Geraci and St. Aubin, 1990). Bratton et al., (1993:721) concludes "bowhead whale encounters with fresh or weathered petroleum most likely present little toxicologic hazard to the integument." Engelhardt (1987:106) found oil contacting whale skin may inflame the epidermis, "*particularly if the oil is light and aromatic, therefore more reactive*". Albert (1981:948) concludes such inflammation ultimately may lead to ulcer formation, severe inflammation of the skin, and possibly blood poisoning.

Bowhead whale eyes may be particularly vulnerable to damage from oil on the water due to their unusual anatomical structure. The presence of a large conjunctival sac associated with the bowheads' eyes was recognized by Dubielzig and Aguirre (1981). The conjunctival sac is a mucous membrane that lines the inner surface of the eyelid and the exposed surface of the eyeball (Zhu, 1996, 1997; Zhu et al., 1998, 1999). This sac likely aids in providing mobility of the eyeball (Zhu, 1996:62). It has been suggested that if oil gets onto the eyes of bowhead whales it would enter the large conjunctival sac (Zhu, 1996:61) and move "inward" 4 to 5 inches (10 to 13 cm) and get "behind" most of the eye (Albert - Pers. Comm., 1997). The consequences of this event are uncertain, but some adverse effects are expected. Detailed study of the anatomy of the bowhead eyes (Zhu, 1996:61) supports speculation that impacts of oil on the eyes of bowhead whales would include irritation, reduced vision due to corneal inflammation, and corneal ulceration potentially leading to blindness (Albert, 1981:947; Zhu, 1996:61).

Bowhead whales may ingest oil encountered on the surface of the sea during feeding, resulting in fouling of their baleen plates. Engelhardt (1987:108) noted that, "*baleen whales are vulnerable to ingesting oil when their baleen structures are coated,*" but the impacts on bowhead whales due to ingestion of oil are unclear. The baleen plates of bowhead whales are fringed with hair-like projections up to 1-ft (0.3 m) long made of keratin (Lambertsen et al., 1989:29-31). These baleen filaments eventually break off and some are swallowed by the whales (Albert, 1981:950; Albert, 1996:7). Filaments also are often observed tangled into 'ball-like' structures while still attached to the baleen of bowheads harvested by Inupiat Eskimos from Barrow (Albert, 1996:7). A laboratory study showed that filtration efficiency of bowhead whale baleen is reduced by 5% to 10% after contact with Prudhoe Bay crude oil (Braithwaite et al., 1983:41). It appeared that when baleen was fouled, viscous crude oil caused abnormal spacing of hairs which allowed increased numbers of plankton to slip through the baleen mechanism without being captured (Braithwaite et al., 1983:42). This loss of baleen filtration efficiency lingered for approximately 30 days. It was uncertain how such reduction would affect the overall health or feeding efficiency of individual whales. In contrast, another study concluded that the most severe effects of baleen fouling are short-lived and interfere with feeding for approximately 1-day after a single exposure of baleen to petroleum (Geraci and St. Aubin, 1983:269; 1985:134). The latter study tested baleen from fin, sei, humpback, and gray whales, but not from bowhead whales. Lambertsen et al. (1989) cautioned against the use of surrogate species in assessing the susceptibility of the bowhead whale to oil, and found that definitive analysis of the impact of oil on bowhead

feeding mechanisms should not be based on the effects of hydraulic pressure alone in powering baleen function.

Thick sludge (tar balls) typically appear in the late stages of an oil spill due to an increase in the specific gravity of oil as evaporation progresses (Meilke, 1990:11). Anatomical evidence suggests that potential impacts of oil and tar balls on the baleen apparatus may be serious. If oil were ingested accidentally during feeding, baleen filaments could be sites of oil adherence, as demonstrated by an oil adherence study conducted on bowhead whale baleen in the laboratory (Braithwaite et al., 1983:41). When dislodged, tarballs likely would be swallowed with other food (Albert, 1981:950). Broken off baleen filaments and tar balls are of concern because of the structure of the bowhead's stomach. The connecting tube between two parts of the bowhead stomach, the fundic chamber and the pyloric chamber, is only about 1.5 inches (3.8 cm) in diameter (Tarpley et al., 1987:303). Everything the whale ingests must pass through this tube, and blockage could pose a major threat to the whale (Albert, 1981:950). Because tar balls may persist in the marine environment for up to 4 years (Meilke, 1990:12), bowhead whales would not have to be present during an oil spill to be adversely affected. Impacts could continue for years.

Consequences of bowhead whales contacting oil have not been well documented. Geraci (1990:169) reviewed a number of studies pertaining to the physiologic and toxic impacts of oil on whales and concluded there was no evidence that oil contamination had been responsible for the death of a cetacean. Cetaceans observed during the *Exxon Valdez* oil spill in Prince William Sound made no effort to alter their behavior in the presence of oil (Harvey and Dahlheim, 1994:263; Loughlin, 1994:366). Following the *Exxon Valdez* oil spill, daily vessel surveys of Prince William Sound were conducted from April 1 through April 9, 1989, to determine the abundance and behavior of cetaceans in response to the oil spill (Harvey and Dahlheim, 1994:263). During the nine surveys, 80 Dall's porpoise, 18 killer whales, and 2 harbor porpoise were observed. Oil was observed on only one individual, which had oil on the dorsal half of its body and appeared stressed due to its labored breathing pattern. However, many cetaceans were observed swimming in the area of the oil slick. A total of 37 cetaceans were found dead during and after the *Exxon Valdez* oil spill, but cause of death could not be linked to exposure to oil (Loughlin, 1994:368). Dahlheim and Matkin (1994) reported 14 killer whales missing from a resident Prince William Sound pod over a period coincident with the *EXXON Valdez* oil spill. Matkin et al., (1994) notes it is likely nearly all of the resident killer whales in Prince William Sound swam through heavily oiled areas, and that the magnitude of that loss was unprecedented. That study concluded there was a correlation between the loss of these whales and the *Valdez* spill, but could not identify a clear cause and effect relationship. Bratton et al., (1993:721) concluded that petroleum hydrocarbons appeared to pose no present harm to bowheads, but also noted that this conclusion was less than definitive because of disagreement over the degree of toxicological hazard posed by hydrocarbons.

Albert (1981:950) warned that exposure to oil could pose a major threat to individual bowhead whales based on their anatomy. Engelhardt (1987:104) stated that bowhead whales are particularly vulnerable to effects from oil spills due to their use of ice edges

and leads where spilled oil tends to accumulate. This author proceeded to suggest ten criteria for assessing whether a given marine mammal species would be vulnerable to the effects of an oil spill. This assessment indicates the bowhead whale is vulnerable to effects of oil because an oil spill could occupy an area of the sea when bowheads were present and the bowhead whale is an endangered species and that damage to the population could be critical to species survival (Engelhardt, 1987:111). In addition, individuals are not expected to avoid oil exposure, based on the limited data discussed previously. The author concluded that: "*population significant impact of oil on marine mammals is likely only in special circumstances, restricted to localities which may, at a certain time of year, host a large proportion of a sensitive population. Species which are considered as threatened and endangered species are additionally vulnerable to oil spills*" (Engelhardt, 1987:112).

Toxicity of crude oil decreases with time as the lighter, more harmful, aromatic hydrocarbons such as benzene evaporate. Acute chemical toxicity (lethal effects) of the oil is greatest during the first month following a spill. Sublethal effects may be observed in surviving birds, mammals, and fish for years after the spill. Sublethal and chronic effects include reduced reproductive success, blood chemistry alteration, and weakened immunity to disease and infections (Spies et al., 1996:10).

Contaminated food sources and displacement from feeding areas also may occur as a result of an oil spill. Rapid recovery of plankton would be expected due to the wide distribution, large numbers, rapid rate of regeneration, and high fecundity of plankton (USDOJ, MMS, 1997B:IV-cj-52). However, regeneration may not be rapid as some plankters, such as certain copepod species, may produce only one generation per year and breed for short periods of time. Nonetheless, it is unlikely that the availability of food sources for bowheads would be affected given the abundance of plankton resources in the Beaufort Sea (Bratton et al., 1993:723).

The impacts of oil exposure to the bowhead whale population would also depend upon how many animals contacted oil. If oil found its way into leads or ice-free areas frequented by migrating bowheads, a significant proportion of the population could be affected. Albert (1981:950) postulated that if spilled oil got into the leads during the spring migration, the oil would pose a grave threat to the bowhead whale by putting nearly the entire population at risk, because most of the bowhead population migrates through the same lead system during a relatively short period. Based on acoustic and visual data, it was estimated that 665 bowheads passed Point Barrow in only 4 days (George et al., 1989:26), and 90% of bowheads passed through an area only 2.5 miles (4 km) wide (George et al., 1995:371). However, several models have considered the probability of bowhead whales encountering a spill, should it occur. By assuming a spill occurred, and factoring in components of 1) an oil spill model, 2) a whale migration model, and 3) a diving-surfacing model, Bratton et al., (1993) concluded a 48.2% chance of 0 whale/oil encounters, a 40% chance of 1-200 encounters, and an 8.9 % chance of 201-400 encounters. Model results indicated a 99% probability that 15 or fewer of every 100,000 surfacings would be in an oil spill if one is present (spills greater than 1,000 barrels).

There are no observations through western science whether bowheads can detect an oil spill or would avoid surfacing in the oil or whether they may be temporarily displaced from an area because of an oil spill or cleanup operations. However, Brower (1980) described the effects of a 25,000-gallon oil spill at Elson Lagoon (Plover Islands) in 1944 on bowhead whales. It took approximately 4 years for the oil to disappear. For 4 years after the oil spill, Brower observed that bowhead whales made a wide detour out to sea when passing near the Elson Lagoon/Plover Islands during fall migration. Bowhead whales normally migrated close to these islands during the fall migration. These observations indicate that some displacement of whales may occur in the event of an oil spill, and that the displacement may last for several years. Based on these observations, it also appears that bowhead whales may have some ability to detect an oil spill and avoid surfacing in the oil by detouring around the area of the spill.

Inupiat of the NSB have expressed concern that the effect on bowhead whales from an oil spill, whether it be into a lead or from the ice as it melts and goes into a lead, could be major because if there is an oil spill, not just a few bowhead whales but potentially the majority, if not the whole population, could be exposed to that oil spill (M. Philo in USDO I, MMS, 1986:14). Whales have reportedly passed within 2 miles (3.2 km) of the spring lead edge during some years and could encounter oil if it was present in a spring lead (J. George in USDO I, MMS, 1995:51-52). Increased activities of vessels and aircraft during oil spill cleanup efforts would be a source of disturbance to migrating bowhead whales. Bowhead whales would likely avoid areas of high noise levels, and the effect could therefore be a temporary change in migration routes. In fact, the potential use of seismic air guns to haze whales from an area of an oil spill may be considered for future response planning. Use of chemical dispersants and burning of oil may have adverse effects on bowheads; however, little is known about whether these activities would pose a threat to the population.

The Inupiat view that an oil spill, especially in broken ice conditions, could have serious consequences to bowhead whales derives from their knowledge that most of the bowhead whale population travels to and from the Canadian Beaufort Sea in a relatively narrow migration corridor during a fairly short time. That a large number of bowheads could be affected by even a relatively small oil spill is illustrated by observations of a whaling captain from Barrow. During a bowhead whale hunt off Barrow in 1976, about 150 to 200 whales were observed in one spot (J. Tukle in USDO I, MMS, 1987:47). Residents have recorded seeing 300 bowhead whales migrating past Barrow in a day, and in 1980, 95% of the population came through in 6 days (G. Carroll in USDO I, MMS, 1986:19). There is general agreement among Inupiat people testifying at various hearings since 1979, that an oil spill would have severe consequences to the bowhead whale population because effective cleanup methods of oil spill in ice-covered waters have not yet been developed and proven (J. Loncar in USDO I, MMS, 1983:49). Recent spill response drills in the Beaufort Sea have failed to demonstrate industry can adequately respond to spilled oil under broken ice conditions (ADEC, 2000).

Oil-spill-cleanup activities during September and October could disturb bowhead whales during their fall migration. No information is available regarding bowhead disturbance from oil-spill-cleanup operations, but noise disturbance to bowheads from vessel and

aircraft traffic involved with cleanup activities likely would be similar to that already described previously. Most oil-spill-cleanup work probably would occur inside the barrier islands, because the spill model indicates that spilled oil has a relatively low probability to reach areas outside of the barrier islands. Some whales may be disturbed by vessel or aircraft traffic and temporarily displaced seaward, if cleanup activities occurred outside the barrier islands or in the channels between the barrier islands during the whale migration. Cleanup activities could continue for multiple seasons. The icebreaking barge Endeavor could be used if a spill occurred during broken-ice conditions in October. Information is not available regarding how far noise can be heard from this vessel during icebreaking operations. Icebreaking activity causes substantial increases in noise levels out to at least 5 kilometers (Richardson et al., 1995). Sounds measured from icebreaking activities by icebreakers and icebreaking supply ships in deeper water have been detected at more than 50 kilometers away (Richardson et al., 1995). The icebreaking barge likely would be operating mostly in shallow water primarily inside the barrier islands, a different environment than icebreaking activity referenced by Richardson et al., (1995). If this vessel were to be used before the end of the bowhead whale fall migration, it is possible some migrating whales could hear the noise. It is likely the shallow water with ice cover and the presence of the barrier islands would greatly reduce the amount of noise reaching migrating whales. Considering this likely reduction in noise levels, the relatively low chance of an oil spill, the estimated size of the spill, the very narrow window of time in October that icebreaking vessel could affect whales, and the relatively low chance that oil would reach bowhead habitat outside the barrier islands, there is low probability that whales would be affected by cleanup activities.

There is still considerable disagreement as to the probable effects of oil on bowhead whales in the Alaskan Beaufort Sea. This conclusion probably reflects the transitory nature of these animals in the region, as well as a lack of studies. Data on the anatomy and migratory behavior of bowhead whales suggest that a large oil spill is likely to adversely affect bowhead whales, especially if substantial amounts of oil were in the lead system during the spring migration (Albert, 1981:950; Shotts et al., 1990:358). Exposure of bowheads to an oil spill could result in lethal effects to an unknown number of individuals.

The MMS modeled several spill scenarios in the Liberty draft EIS. These included pipeline spills, a platform crude oil spill, and a 1,283-barrel diesel oil spill. All spills modeled were in excess of 500 barrels. The chance of an oil spill greater than or equal to 500 barrels from the offshore production island and the buried pipeline occurring and entering the offshore waters was estimated to be on the order of 1%. A spill of 715-2,956 barrels could contact areas outside the barrier islands where bowhead whales may be present. A spill during broken ice in the fall or under the ice in the winter would melt out during the following summer.

During the summer, the MMS estimates the chance of an oil spill from Liberty Island (LI) contacting habitat where bowhead whales may be found during their fall migration ranges from less than 0.5-15% over a 30-day period and less than 0.5-16% over a 360-day period, respectively. If any bowheads migrated on the shoreward side of Cross

Island during an oil spill, there is an 11% and a 12% chance of contact with spilled oil over both a 30-day and a 360-day period, respectively. Although a few bowheads may be inside the barrier islands during the fall migration, this area is not their main habitat.

During the winter, the chance of an oil spill from Liberty Island contacting these habitat areas ranges from less than 0.5-2% over a 30-day period and less than 0.5-5% over a 360-day period, respectively. The model estimated there is less than a 0.5% chance of an oil spill from Liberty Island contacting the spring lead system over both a 30-day period and a 360-day period during either the summer or winter.

During the summer, the chance of an oil spill *from the offshore portion of the pipeline* reaching bowhead habitat ranges from less than 0.5-13% over a 30-day period and from 0.5-14% over a 360-day period. If any bowheads migrated on the shoreward side of Cross Island during an oil spill, there is a 9% and a 10% chance of contact with spilled oil over both a 30-day and a 360-day period, respectively.

A 1,283-barrel spill of diesel oil from Liberty Island would persist for a shorter period of time in the marine environment than a crude oil spill. Approximately 14 % of the diesel oil would remain after 3 days, and 2% would remain after 7 days if the spill occurred during the summer. The chance of a diesel oil spill during the summer contacting bowhead habitat during the fall migration range from less than 0.5-6% over a 3-day period.

IV. Cumulative Effects

Cumulative effects include the “effects of future State, local, or private actions, that are reasonably certain to occur in the action area. Reasonable foreseeable future federal actions and potential future federal actions that are unrelated to the proposed action are not considered in the analysis of cumulative effects because they would require separate consultation pursuant to section 7 of the ESA. These effects differ from those that may be attributed to past and ongoing actions within the area since they are considered part of the environmental baseline.

The State of Alaska Five-Year Oil and Gas Leasing Program published in January 1999 lists five Beaufort Sea areawide lease sales scheduled beginning in October 1999 and continuing with additional sales in 2000, 2001, 2002, and 2003. The proposed sales consists of all unleased tide and submerged lands between the Canadian Border and Point Barrow as well as some upland acreage. The October 1999 sale was delayed. The most recent State sale in the Beaufort Sea was held in November 2000. Federal OCS Lease Sale 170 was held in August 1998 and there are still active leases from previous Federal lease sales. Another Federal OCS sale planned for about 2002 has been delayed. A Federal onshore sale was held in the Northeast National Petroleum Reserve-Alaska. Additional noise and disturbance from exploratory activities similar to those described below for previous Federal and State lease sales could occur if any of the scheduled sales for the Beaufort Sea area are held.

The potential for oil-industry activities outside of the Alaskan Beaufort Sea appears to be limited. Two Federal lease sales were conducted previously in the Chukchi Sea and exploration activities were conducted, but no producible wells were discovered. A Chukchi Sea/Hope Basin sale was included in the 1997-2002 OCS oil and gas leasing program, but there are currently no plans to hold the lease sale. Nor are there currently any plans for future oil and gas exploration activities in the Bering Sea. In the Canadian Beaufort Sea, the main area of industry interest has been around the Mackenzie River Delta and offshore of the Tuktoyaktuk Peninsula. Although there have been oil discoveries in these areas, there has been little industry interest in the area in recent years and we are not aware of any activities planned for the Canadian Beaufort Sea. Bowhead whales could be affected should any oil and gas activities occur in the Canadian Beaufort Sea during the summer.

Flaxman Island and Gwydyr Bay are reasonably foreseeable future offshore development projects on State leases that are considered uneconomical to develop now but may become economical during the next 15-20 years. Flaxman Island is a barrier island east of Prudhoe Bay and near the western edge of Camden Bay. Development of the Flaxman Island unit likely will share infrastructure with the Badami group. Although the Badami field is located offshore, industry will drill the Badami field from onshore. The unit likely would have its own production pads and wells and a pipeline connecting it to a past or present development project associated with Badami. The Badami field is of particular interest, because the Liberty project pipeline will tie into Badami's crude-carrier pipeline. Developmental drilling is under way for the Badami field, and pipeline construction is scheduled. Gwydyr Bay is shoreward of the barrier islands, where development activities may have less affect on bowhead whales.

The State of Alaska's Division of Oil and Gas offers State lands to be leased for oil and gas exploration and production through their lease sale program. Area wide sales of state-owned tidal and submerged land in the Alaskan Beaufort Sea, between Point Barrow and the Canadian Border, are scheduled annually through 2005. The most recent sale (2000) resulted in the leasing of 11 tracts. Hydrocarbon potential is considered low to moderate. Bowhead whales are normally found offshore of State waters, although they do occur nearshore, particularly at Pt. Barrow and near Kaktovik. Exploration and development of State-owned leases in the Beaufort Sea could subject bowhead whales to many of the same disturbances and potential impacts associated with Federal OCS leasing. Oil and gas activities here would add to the cumulative effect on bowhead whales, particularly with respect to noise and the potential for oil spills, the effects of which would be likely to extend beyond State waters. Because the main axis of the bowhead migration is well offshore of State waters, it is unlikely these activities would alter the migrational path.

Future exploration and development within the Canadian Beaufort would present concerns beyond those associated with leasing in the Alaskan Beaufort Sea. The main area of industry interest has been the Mackenzie Delta and offshore of the Tuktoyaktuk Peninsula (MMS, 1995). The large estuarine front associated with the Mackenzie Delta and upwellings near the Tuktoyaktuk Peninsula provide conditions which concentrate

zooplankton (Moore and Reeves, 1993). These areas are important feeding habitat to the Bering Sea stock. There are no reported plans for oil and gas exploration or production within the Canadian Beaufort Sea at this time (D. Matthews, pers. comm.) however, and this activity would not be considered reasonably expected to occur.

Cumulative effects of offshore oil and gas leasing would include avoidance behavior and alteration of migration patterns by bowhead whales as a result of increased barge and vessel traffic during the open water season. Increased traffic also would increase the likelihood of accidental oil and fuel spills affecting bowhead whales. Impacts to bowhead whales from future oil and gas projects likely would be similar in magnitude and significance to impacts from activities associated with this project, assuming that future offshore development occurs at similar water depths (less than 60 ft [18.3 m]) and that islands are connected to shore only via subsea buried pipelines. These impacts could be magnified, however, if construction activity associated with additional development projects were to occur simultaneously, rather than consecutively. For example, construction and drilling noise from multiple drilling sites could result in a long-term, offshore shift in bowhead migration routes. The extra distance and heavier ice encountered could result in slower migration or physiological stress that may noticeably affect the whales. However, the majority of bowhead whales are generally found offshore of State waters.

Underwater noise levels are likely to increase locally in the Alaskan Beaufort Sea as a consequence of increased oil and gas exploration and development. Bowhead whales are likely to be affected the most from this development. At least some bowhead whales would avoid certain areas of the Beaufort Sea as a result of industrial noise. This seaward displacement would not be limited to the actual operational phase of future developments but would also occur during seismic exploration and construction. These displacement effects may last more than 15 years (i.e. for as long as the oil development activity occurs). Cumulative impacts from seismic surveys would affect bowhead whales. Bowheads exposed to noise-producing activities associated with the project, and other future projects in the Alaskan Beaufort Sea, would most likely experience temporary nonlethal effects associated with the high noise levels during shooting. Bowheads would likely avoid seismic vessels during these operations. Bowhead avoidance response due to noise and activity would result in longer travel distances for whaling activities and associated risk and reduced success. Observations by members of the whaling community suggest that exposure to high noise levels would displace bowhead whales seaward. It is also possible for the cumulative effects of longer exposure to noise to cause mechanical damage to the bowhead's inner ear, with resultant loss or reduction in hearing.

The probability of an oil spill increases as more oil fields become active. The potential effects of oil on bowhead whales have been presented. It is assumed bowhead whales would be susceptible to an oil spill during feeding and migration, particularly if they came in contact with oil in the lead system during spring migration. A number of small oil spills have occurred during oil and gas exploration in the Alaskan Beaufort Sea in past years. Only five spills have been greater than one barrel, and the total spill volume from drilling 52 exploration wells (1982 through 1991) was 45 barrels (USDOJ, MMS,

1996A:IV.A-10). Based on historical data, most oil spills would be less than one barrel, but a larger oil spill could also occur. Considering the low probability that a spill would occur, the limited number of days each year that bowhead whales would be migrating through the area, and the probability for spilled oil to move into the migration corridor of the bowheads, it is unlikely that bowhead whales would be contacted by oil. Significant adverse effects would only be expected if all of the low probability events occurred at the same time.

The annual subsistence hunting of bowhead whales by Inupiat whalers is expected to continue into the foreseeable future. The IWC has established a 5-year block quota of 280 whales. The IWC's Scientific Committee has determined this level of removals will allow growth within the stock.

Private shipping activity will occur into the future, and would result in possible harassment to bowhead whales as discussed for the Northstar project. This disturbance is considered to be localized and temporary. No other private actions which would affect the bowhead whale have been identified.

VI. Summary and Synthesis of the Effects

This Opinion has considered the anticipated effects of the Liberty project on the endangered bowhead whale. Construction and operation may affect these animals due to vessel and aircraft traffic, construction noise, and drilling and operating noises from Liberty Island. Noise has been shown to alter the behavior and movements of the bowhead whale. Noise may also alter the hearing ability of these whales, causing temporary or permanent threshold shifts. There is, at present, insufficient information on the hearing ability and sensitivities of bowhead whales to adequately describe this potential. However, information presented in the DEIS for the Liberty project suggests most continuous and impulsive underwater noise levels associated with construction, development, and production activities would be at levels below those expected to injure hearing mechanisms of bowhead whales. Noise has also been shown to cause avoidance in migrating bowhead whales. The possible use of an ice-strengthened barge pushed by tugs would appear to present the highest probability for avoidance of any of the activities associated with the Liberty project. Studies have shown noise from ice breakers may be recorded at distances exceeding 50 km. The distance at which bowheads may detect or react to such noise is poorly described. The use of ice-strengthened barges may have less impact than large ice breaking vessels, however no data could be found describing noise from such activity. Davies (1997) concludes bowheads also avoided an active drilling rig at a distance of 20 km. The impacts of noise emanating from an artificial island such as Liberty are likely to be much less than that from drilling rigs, and would be expected to have less effect on whales. Using bowhead migrational data from 1997, a year in which whales passed close to shore, and a 3.2 km radius (representing the range at which Liberty Island noise is projected to decay to a level of 115 dB re 1 μ Pa), fewer than 15 bowhead whales are expected to be taken by harassment due to this project (LGL 1998).

While we do not expect that such deflections during migration will be injurious to individual animals, concern is warranted for cumulative noise and multiple disturbance;

the consequences of which might include long-term shifts in migrational paths or displacement from nearshore feeding habitats. However, we do not believe it is likely that these effects would result in reductions in the distribution, reproduction, or numbers of bowhead whales which would be expected to appreciably reduce their likelihood of survival and recovery since the Beaufort Sea remains principally a migrational corridor for the bowhead whose primary feeding habitat is considered to be in the Canadian Beaufort and, perhaps, the Bering Sea (Schell, 1998.).

Because the main bowhead whale-migration corridor is approximately 10 kilometers seaward of the barrier islands, drilling and production noise from Liberty Island is not likely to reach most of the migrating whales. The few whales that may be present in lagoon entrances or inside the barrier islands may be behaviorally affected by noise. Marine-vessel traffic outside of the barrier islands is likely to be limited to seagoing barges transporting equipment and supplies from Southcentral Alaska to the Liberty location, most likely between mid-August and mid- to late September. If the barge traffic continues into September, some bowheads may be disturbed. Whales exposed to the barge traffic may exhibit avoidance behavior to the vessels at distances of 1-4 kilometers from the traffic corridors. Fleeing behavior generally stops within minutes after a vessel has passed, but may persist for a longer time. Vessel and aircraft traffic inside the barrier islands is not expected to affect bowhead whales. Much of the island and pipeline construction activities will be conducted during the winter and are well inside the barrier islands, reducing potential impact to bowhead whales. While disturbances to the few individual whales present within the barrier islands may occur, we do not believe it is reasonable to expect that these disturbances will result in more than temporary disruptions to the normal behavior of these whales. Likewise, we do not believe that whales exposed to noise and disturbances from barge traffic outside the barrier islands will experience more than temporary disruptions to normal behaviors. Overall, we do not expect noise and disturbance associated with the Liberty project is likely to reduce appreciably the likelihood of the survival and recovery of bowhead whales in the wild by reducing their reproduction, numbers, or distribution.

Consideration of the potential impacts of oil spills to the bowhead whale must assess 1) the probabilities for a spill to occur and to make contact with the whales and/or their habitat, 2) the effects of oil spills and spill responses on these whales, and 3) the ability of industry to prevent, control, and recover spilled oil. Most spill potential is attributed to the oil pipeline, as the probabilities for well blowouts and tank rupture are considerably less. The chance of an oil spill greater than or equal to 500 barrels from the offshore production island and the buried pipeline occurring and entering the offshore waters is estimated to be on the order of 1%. If spilled, oil from operations at the Liberty project would have a 16% or less chance of contacting bowhead whale habitat over a 360-day period.

The physical and behavioral effects of an oil spill on the Bering Sea stock of bowhead have been described earlier in this Opinion. While it is clear additional research is needed to assess these effects and that no consensus has been reached regarding the degree to which oiling might impact bowhead whales, we believe that whales contacting oil, particularly freshly-spilled oil, could be harmed and possibly killed. Additionally, an

oil spill reaching into the spring lead system has the potential to contact a significant number of whales within the Bering Sea stock. Several coincidental events would be necessary for this scenario; the spill would have to occur, the spill would have to coincide with the seasonal migration, the spill would have to be transported to the area the whales occupy (e.g. the migrational corridor or spring lead system), and clean-up or response efforts would have to have been at least partially unsuccessful. The impact of such an event could be significant, yet the statistical probability for the coincidence of these events would be low. It must also be recognized that the spring lead system is not static, as leads open and close and whales navigate not only through the leads but surrounding ice (Clark and Ellison, 1988). Because of this it is difficult to assess the potential number of whales which could be impacted. Some whales may be displaced seaward if cleanup activities occurred outside the barrier islands or in the channels between the barrier islands during the whale migration.

The ability to prevent, identify, locate, contain, and remove spilled oil is a significant concern. The NMFS believes that, while spills represent low-probability events, their biological impacts are significant and the operator should make every reasonable effort to meet these challenges. We are especially concerned with the ability to contain and recover spilled oil under broken ice conditions (i.e. 30-70% ice coverage), and to detect chronic leakage below threshold detection limits on the pipeline. Based on the low combined probability that an accidental oil spill will occur and contact bowhead whales in the action area, we do not believe it is reasonable to expect that the development and operation of the Liberty project will reduce appreciably the likelihood of the survival and recovery of bowhead whales in the wild by reducing their reproduction, numbers, or distribution.

The additive or combined impacts of all bowhead "takes", described in the Environmental Baseline, must also be considered in any assessment of this work. The annual aboriginal harvest (subsistence) quota for this stock is currently 82 strikes. This harvest has been on-going for over two decades. During the period 1978-1993, the population has increased at a rate of 3.1% (Ferrero et al. 2000), suggesting this rate of removal is not significant in terms of survival or recovery.

The small take authorizations in effect for the 2001 open water season would permit the taking of a best estimate of 1758 whales, with a maximum estimate of 5766. These estimates represent a significant portion of the Bering Sea stock of bowhead whales. However, all of these takes would be by harassment, largely due to noise, which should not pose any injurious conditions to these whales. Additionally, some of these estimates were based on the "20 km criterion" which derives from observations of bowhead whales in the Beaufort Sea exposed to high energy seismic activity. While there are few data at this time on the avoidance distance for bowheads from artificial production islands such as Liberty, it is probable that these distances would be less than those observed during seismic, with its higher source levels. Nonetheless, NMFS is concerned over the repeated exposure of migrating bowhead whales to noise. While whales may deflect around a single noise source before returning to their migratory path, continuous or repeated exposures may cause some whales to change their normal routes, possibly offshore into deeper waters. The consequences of that action are also unknown. Site

specific monitoring and the on-going MMS bowhead whale aerial survey program may provide data to monitor and assess any such effect.

VII. Conclusion

After reviewing the current status of the Bering Sea stock of the bowhead whale, the environmental baseline for the action area, the effects of the construction, development and production activities associated with the proposed Liberty project, and cumulative effects, it is NMFS's biological opinion that this activity is not likely to jeopardize the continued existence of the endangered bowhead whale. No critical habitat has been designated for this species, therefore none will be affected.

VIII. Incidental Take Statement

Section 9 of the ESA and Federal regulations pursuant to section 4(d) of the ESA prohibit the take of endangered and threatened species, respectively, without special exemption. Take is defined as to harass, harm, pursue, hunt, shoot, wound, kill, trap, capture or collect, or to attempt to engage in any such conduct. Incidental take is defined as take that is incidental to, and not the purpose of, the carrying out of an otherwise lawful activity. Under the terms of section 7(b)(4) and section 7(o)(2), taking that is incidental to and not intended as part of the agency action is *not considered to be prohibited* taking under the ESA provided that such taking is in compliance with the terms and conditions of this Incidental Take Statement.

The National Marine Fisheries Service is not including an incidental take statement at this time because the incidental take of marine mammals (i.e. bowhead whales) has not been authorized under Section 101(a)(5) of the Marine Mammal Protection Act and/or its 1994 Amendments. Following issuance of such regulations or authorization, NMFS may amend this Biological Opinion to include an incidental take statement for bowhead whales.

IX. Conservation Recommendations

Section 7(a)(1) of the ESA directs Federal agencies to utilize their authorities to further the purposes of the Act by carrying out conservation programs for the benefit of endangered and threatened species. Conservation recommendations are discretionary agency activities to *minimize or avoid* adverse effects of a proposed action on listed species or critical habitat, to help implement recovery plans, or to develop information. The National Marine Fisheries Service recommends the Minerals Management Service implement the following measures for these purposes.

1. Vessel operations should be scheduled to minimize operations after August 31 of each year in order to reduce potential harassment of migrating bowhead whales. Vessel routes should be established which maximize separation with the bowhead whale migration corridor, remaining within the 18m depth contour and behind the barrier islands when practicable. During fall broken ice conditions, supply and crew changes between

Deadhorse and Liberty Island should be accomplished with helicopters rather than vessels to the extent possible, especially if those vessels would employ ice breaking.

2. Agitation techniques for placement of sheetpiling and piling should be utilized instead of pile-driving whenever practicable.

3. MMS should develop and conduct an acoustic monitoring study to measure the frequency composition of noise and noise levels as a function of distance from Liberty Island during construction and initial operation.

4. MMS should conduct or support studies to describe the impact of the Liberty facility on the migrational path of the bowhead whale in the Beaufort Sea.

5. MMS should ensure that no vessels associated with the Liberty Project engage in active ice management in the Beaufort Sea between August 15 and October 15 of each year, except during spill response training exercises or in response to an actual spill event. All spill response training exercises which employ ice breaking between August 15 and October 15 should be restricted to waters inside the 15 meter (45 foot) bathymetric contour. This is intended to allow unimpeded access to Liberty Island and Endicott or West Dock facilities for spill response training exercises. No restrictions are necessary for the use of ice breaking equipment necessary for response during an actual spill event, or other bona fide emergency.

6. Island construction should provide for barge mooring facilities early in the construction sequence, to prevent the need for continuously-operating self propelled barges. Studies at the similar Northstar project found such activity produced very strong noise levels which extended out to great distances; with the potential to effect greater numbers of bowhead whales.

X. Reinitiation of Consultation

This concludes formal consultation on this action. As provided in 50 CFR §402.16, reinitiation of formal consultation is required where discretionary Federal agency involvement or control over the action has been retained (or is authorized by law) and if: (1) the amount or extent of incidental take is exceeded; (2) new information reveals effects of the agency action that may affect listed species or critical habitat in a manner or to an extent not considered in this Biological Opinion; (3) the agency action is subsequently modified in a manner that causes an effect to the listed species or critical habitat not considered in this Biological Opinion; or (4) a new species is listed or critical habitat designated that may be affected by this action. In circumstances where the amount or extent of incidental take is exceeded, the Minerals Management Service must immediately request reinitiation of formal consultation.

BIBLIOGRAPHY

Alaska Clean Seas and Beaufort Sea Members Companies. 1983. Alaskan Beaufort Sea coastal region: Alaska Clean Seas contingency planning manual supplement. Vol.s. 1 and 2. Anchorage: ACS.

Alaska Department of Environmental Conservation. 2000. Joint agency evaluation of the spring and fall 2000 north slope broken ice exercises. Report prepared by Alaska Department of Environmental Conservation, North Slope Borough, Alaska Department of Natural Resources, Minerals Management Service, and U.S. Coast Guard. 47p.

Albert, T.F. 1981. Some thoughts regarding the possible effects of oil contamination on bowhead whales, *Balaena mysticetus*. In: Tissue structural studies and other investigations on the biology of endangered whales in the Beaufort Sea, T.F. Albert, ed. Volume II. Anchorage, AK: USDO, BLM.

Albert, Thomas F. 1996. Concerns regarding offshore industrial impacts to bowhead whales. Letter report to Tom Lohman. May 30, 1996. Prepared by North Slope Borough, Department of Wildlife Management. Barrow: NSB.

Blackwell, Susanna B. and Charles R. Greene Jr. 2001. Sound measurements, 2000 break-up and open water seasons. In: Monitoring of industrial sounds, seals, and whale calls during construction of BP's Northstar oil development, Alaskan Beaufort Sea, 2000. LGL and Greene ridge Sciences Inc. April 2001.

Bockstoce, J.R. 1986. Whales, ice, and men: the history of whaling in the western Arctic. Univ. Wash. Press, Seattle, 400p.

Bockstoce, J.R., and D.B. Botkin. 1983. The historical status and reduction of the western arctic bowhead whale (*Balaena mysticetus*) population by the pelagic whaling industry, 1848-1914. Rep. Int. Whal. Comm., Spec. Iss. 5:107-141.

BPXA. 1998. Liberty Development Project. Environmental Report. Anchorage, AK: BPXA, 9 chapters + appendices.

Braithwaite, Lee F., Michael G. Aley, and David L. Slater. 1983. The effects of oil on the feeding mechanism of the bowhead whale. Final report. Contract No. AA 851-CTO-55. Prepared for the U.S. Department of the Interior by Brigham Young University, Utah. Salt Lake City: BYU, 1983.

Bratton, Gerald R., Charles B. Spainhour, Wayne Flory, Mark Reed, and Katherine Jayko. 1993. "Presence and potential effects of contaminants." In: The Bowhead Whale. Eds. J.J. Burns, J.J. Montague, C.J. Cowles. The Society for Marine Mammalogy. Special Publication Number 2. Lawrence: Allen Press, Inc., 1993. 764.

- Brower, T.P. 1980. Qiniqtuagaksrat Utuqqanaat Inuuniagninisiqu: The Traditional Land Use Inventory for the Mid-Beaufort Sea. Vol. I. Barrow, AK: North Slope Borough, Commission on History and Culture.
- Burns, John J., J. Jerome Montague, and Cleveland J. Cowles. 1993. The Bowhead Whale. The Society for Marine Mammalogy. Special Publication Number 2. Lawrence: Allen Press, Inc.
- Clark, Christopher W., William T. Ellison, and Kim Beeman. 1987. "Acoustic Tracking of Migrating Bowhead Whales." Oceans 86 Conference Record. Hosted by the Washington D.C. Section of the Marine Technology Society, 23-25 Sept. 1986, Washington, D.C. 86CH2363-0. Vol. 1: Systems, Structures and Analysis. N.p.: Marine Technology Society, 1987.
- Clark, C.W., and W.T.Ellison. 1988. Numbers and distributions of bowhead whales, *Balaena mysticetus*, based on the 1985 acoustic study off Pt. Barrow, Alaska. Rept. Int. Whal. Comm. 38:365-370.
- Cosens, S.E., T. Qamukaq, B.Parker, L.P. Dueck, and B. Anardjuak. 1997. The distribution and numbers of bowhead whales, *Balaena mysticetus*, in northern Foxe Basin in 1994. Can Field Nat. 111:381-388.
- Dahlheim, M.E. and C.O. Matkin. 1994. Assessment of Injuries to Prince William Sound Killer Whales. In: Marine Mammals and the *Exxon Valdez*, T.R. Loughlin, ed. San Diego, CA: Academic Press, pp. 163-172.
- Davies, Jeremy Rhys. 1997. "The Impact of an Offshore Drilling Platform on the Fall Migration Path of Bowhead Whales: A GIS-Based Assessment." Diss. for Western Washington University. N.p.: WWU.
- Davis, R., and W. Koski. 1980. Recent observations of the bowhead whale in the eastern Canadian high Arctic. Rep. Int. Whal. Comm. 30:439-444.
- Davis, R.A., C.R. Greene, and P.L. McLaren. 1985. Studies of the Potential for Drilling Activities on Seal Island to Influence Fall Migration of Bowhead Whales Through Alaskan Nearshore Waters. King City, Ontario: LGL Limited Environmental Research Associates, 70 pp.
- Dubielzig, R. and G. Aguirre. 1981. Morphological studies of the visual apparatus of the bowhead whale, *Balaena mysticetus* (RU480). In: Tissue structural studies and other observations on the biology of endangered whales in the Beaufort Sea. T.F. Albert, ed. Draft rep. to the Bureau of Land Management from the Univ. of Maryland, College Park.
- Ellison, William T., Christopher W. Clark, and Garner C. Bishop. 1987. "Potential Use of Surface Reverberation by Bowhead Whales, *Balaena mysticetus*, in Under-Ice

Navigation: Preliminary Considerations." Thirty-Seventh Report of the International Whaling Commission. N.p.: Cambridge, 1987.

Engelhardt, F. R. 1987. "Assessment of the Vulnerability of Marine Mammals to Oil Pollution." Fate and Effects of Oil in Marine Ecosystems. Proceedings of the Conference on Oil Pollution Organized Under the Auspices of the International Association on Water Pollution Research and Control (IAWPRC) by the Netherlands Organization for Applied Scientific Research. TNO Amsterdam, 23-27 Feb. 1987, The Netherlands. Eds. J. Kuiper, and W. J. Van Den Brink. Boston: Martinus Nijhoff Publishers, 1987.

Ferrero, R.C., D.P. DeMaster, P.S. Hill, M.M. Muto, and A.L. Lopez. 2000. Alaska marine mammal stock assessments, 2000. U.S. Dept. Commerce. NOAA Tech. Memo. NMFS-AFSC-119, 191p.

George, John C., Christopher Clark, Geoff M. Carroll, and William T. Ellison. 1989. "Observations on the Ice-Breaking and Ice Navigation Behavior of Migrating Bowhead Whales (*Balaena mysticetus*) Near Point Barrow, Alaska, Spring 1985." *Arctic* 42.1 (1989): 24-30.

George, J.C., L.M. Philo, K. Hazard, D. Withrow, G.M. Carroll, and R. Suydam. 1994. Frequency of killer whale (*Orcinus orca*) attacks and ship collisions based on scarring on bowhead whales (*Balaena mysticetus*) by Alaskan Eskimos. *Rep. Int. Whal. Comm.* 42:479-483.

George, J.C.; Suydam, R.S.; Philo, L.M.; Albert, T.F.; Zeh, J.E.; and Carroll. 1995. Report of the Spring 1993 Census of Bowhead Whales, *Balaena mysticetus*, off Point Barrow, Alaska, with Observations on the 1993 Subsistence Hunt of Bowhead Whales by Alaska Eskimos. *Rep. Int. Whal. Comm.* 45:371-384.

Geraci, J.R. 1990. Physiologic and toxic effects on cetaceans. pp. 167-192. *In: Sea mammals and oil: confronting the risks* J.R. Geraci and D.J. St. Aubin, Editors. First ed., Academic Press, Inc. San Diego, California: 239 p.

Geraci, J. R., and D. J. St. Aubin. 1985. *Expanded Study of the Effects of Oil on Cetaceans, Final Report, Part I*. Contract 14-12-0001-29169. Prepared for U.S. Department of the Interior, Bureau of Land Management, Washington, D.C. by the University of Guelph, Ontario. N.p.: n.p., 1985.

---. "A Study to Determine If Gray Whales Detect Oil." 1983. Study of the Effects of Oil on Cetaceans. Contract AA 551-CT9-29. Prepared for U.S. Department of the Interior, Bureau of Land Management, Washington, D.C. by the University of Guelph, Ontario. N.p.: n.p., 1983.

Geraci, J.R. and D.J. St. Aubin, eds. 1990. *Sea Mammals and Oil: Confronting the Risks*. San Diego, CA: Academic Press, 282 pp.

Greene, C.R. 1997. Under-ice Drillrig Sound, Sound Transmission Loss, and Ambient Noise near Tern Island, Foggy Island Bay, Alaska, February 1997. Greeneridge Report 187-1. Santa Barbara, CA: Greeneridge Sciences, Inc., 22 pp.

Greene, C.R. 1998. Underwater Acoustic Noise and Transmission Loss During Summer at BP's Liberty Prospect in Foggy Island Bay, Alaskan Beaufort Sea. Greeneridge Report 189-1. Santa Barbara, CA: Greeneridge Sciences, Inc., 39 pp.

Haldiman, J.T., Y.Z. Abdelbaki, F.K. Al-Bagdadi, D.W. Duffield, W.G. Henk, and R.W. Henry. 1981. Determination of the Gross and Microscopic Structure of the Lung, Kidney, Brain, and Skin of the Bowhead Whale, *Balaena mysticetus*. In: Tissue Structural Studies and Other Investigations on the Biology of Endangered Whales in the Beaufort Sea, T.F. Albert, ed. Vol. I. Anchorage, AK: USDOJ, BLM.

Haldiman, J.T., W.G. Henk, R.W. Henry, T.F. Albert, Y.Z. Abdelbaki, and D.W. Duffield. 1985. Epidermal and Papillary Dermal Characteristics of the Bowhead Whale, (*Balaena mysticetus*). *Anatomical Record* 211:391-402.

Harvey, J.T. and M.E. Dahlheim. 1994. Cetaceans in Oil. In: Marine Mammals and the Exxon Valdez, T.R. Loughlin, ed. San Diego, CA: Academic Press, pp. 257-264.

Henk, W.G. and D.L. Mullan. 1996. Common Epidermal Lesions of the Bowhead Whale (*Balaena mysticetus*). *Scanning Microscopy Intl.* 103:905-916.

International Whaling Commission. 1996. Report of the scientific committee. Rep. Int. Whal. Com. 46:51-97

International Whaling Commission Scientific Committee (IWC). 1995. "Report to the Sub-Committee on Aboriginal Subsistence Whaling." Forty-Fifth Report of the International Whaling Commission. N.p.: Cambridge.

International Whaling Commission. 1992. Chairman's report of the forty-third annual meeting. Rep. Int. Whal. Comm. 42: 11-50.

Johnson, S.R., C.R. Greene, R.A. Davis, and W.J. Richardson. 1986. Bowhead Whales and Underwater Noise near the Sandpiper Island Drillsite, Alaskan Beaufort Sea, Autumn 1985. King City, Ontario: LGL Limited Environmental Research Associates, 130 pp.

Koski, W.R. and S.R. Johnson. 1987. Behavioral Studies and Aerial Photogrammetry. In: Responses of Bowhead Whales to an Offshore Drilling Operation in the Alaskan Beaufort Sea, Autumn 1986. Anchorage, AK: Shell Western E&P, Inc.

Koski, William R., Rolph A. Davis, Gary W. Miller, and David Withrow. 1993. "Reproduction." In: The Bowhead Whale. Eds. J.J. Burns, J.J. Montague, C.J. Cowles.

The Society for Marine Mammalogy. Special Publication Number 2. Lawrence: Allen Press, Inc.

LaBelle, R.P. C.M. Marshall, C. Anderson, W. Johnson, and E. Lear. 1996. Oil Spill Risk Analysis for Alaska North Slope Oil Exports (Domestic Movement). Herndon, VA: USDOl, MMS, 9 pages + tables.

Lambertsen, R. H., Raymond J. Hintz, Winston C. Lancaster, Amy Hirons, Kerry Jo Kreiton, and Cindy Moor. 1989. Characterization of the Functional Morphology of the Mouth of the Bowhead Whale, *Balaena mysticetus*, With Special Emphasis on Feeding and Filtration Mechanisms. NSB Contract 87-113. Prepared for the Department of Wildlife Management, North Slope Borough, Barrow, Alaska. Barrow: NSB, 1989.

LGL, Ltd., and Greeneridge Sciences Inc. (LGL and Greeneridge). 1987. Responses of Bowhead Whales to an Offshore Drilling Operation in the Alaskan Beaufort Sea, Autumn 1986. Prepared for Shell Western E & P Inc. by LGL, Ltd. and Greeneridge Sciences, Inc.

LGL, Ltd. 1998. Petition for regulations pursuant to section 101 (a)(5) of the Marine Mammal Protection Act covering taking of marine mammals incidental to offshore oil and gas development and production in the Beaufort Sea, Alaska. Prepared by LGL Alaska Research Associates, Inc. and LGL Limited for BP Exploration (Alaska) Inc.

Lipscomb, Thomas P., Richard K. Harris, Alan H. Rebar, Brenda E. Ballachey, and Romona J. Haebler. 1994. "Pathology of Sea Otters." *Marine Mammals and the Exxon Valdez*. 1st ed. Ed. Thomas R. Loughlin San Diego: API, 1994. 265-80.

Ljungblad, D.K., S.E. Moore, J.T. Clarke, and J.C. Bennett. 1987. Distribution, Abundance, Behavior, and Bioacoustics of Endangered Whales in the Alaskan Beaufort and Eastern Chukchi Seas, 1979-86. OCS Study, MMS 87-0039. NOSC Technical Report 1177. Anchorage, AK: USDOl, MMS, 362 pp.

Loughlin, T.R. 1994. *Marine Mammals and the Exxon Valdez*. San Diego CA: Academic Press.

Lowry, L.F. 1993. Foods and Feeding Ecology. *In: The Bowhead Whale Book*, J.J. Burns, J.J. Montague, and C.J. Cowles, eds. Special Publication of The Society for Marine Mammalogy, 2. Lawrence, KS: The Society for Marine Mammalogy, pp. 201-238.

Matkin, Craig O., G.M. Ellis, M.E. Dahlheim, and J. Zeh. 1994. Status of killer whales in Prince William Sound, 1985-1992. *In: Marine Mammals and the EXXON Valdez*. 1994. T. R. Loughlin, Ed. Academic Press. 395 p.

MBC Applied Environmental Sciences (MBC). 1997. Arctic Seismic Synthesis and Mitigating Measures Workshop, Draft Proceedings. OCS Study MMS 97-0014. Sponsored by U.S. Department of Interior, Minerals Management Service, 5 - 5

March 1997, Barrow, Alaska. Proceedings prepared for U.S. Department of Interior, Minerals Management Service by MBC Applied Environmental Sciences. Costa Mesa: MBC, 1997.

Meilke, James E. 1990. Oil in the Ocean: The Short- and Long-Term Impacts of a Spill. Congressional Research Service Report for Congress, July 24, 1990. Washington, D.C.: Library of Congress, 1990.

Miller, G.W., R.E. Elliott, and W.J. Richardson. 1996. Marine Mammal Distribution, Numbers and Movements. *In*: Northstar Marine Mammal Monitoring Program, 1995: Baseline Surveys and Retrospective Analyses of Marine Mammal and Ambient Noise Data From the Central Alaskan Beaufort Sea . LGL Report TA 2101-2. King City, Ontario, Canada: LGL Ecological Research Associates, Inc.

Miller, G.W., R.E. Elliott, W.R. Koski, and W.J. Richardson. 1997. Whales. *In*: Northstar Marine Mammal Monitoring Program, 1996: Marine Mammal and Acoustical Monitoring of a Seismic Program in the Alaskan Beaufort Sea ., LGL and Greeneridge. LGL Report TA 2121-2. King City, Ontario, Canada: LGL Ecological Research Associates, Inc.

Mitchell, E.D. 1977. Initial population size of bowhead whale (*Balaena mysticetus*) stocks: cumulative catch estimates. *Int. Whal. Comm. Unpubl. Doc. SC/29/33*. 113p.

Moore, Sue E., and J. T. Clarke. 1992. Final Report: Distribution, Abundance and Behavior of Endangered Whales in the Alaskan Chukchi and Western Beaufort Sea, 1991: With a Review of 1982-91. OCS Study, MMS 92-0029. Prepared for the U.S. Department of the Interior Minerals Management Service, Alaska OCS Region by SEACO, a Division of Science Applications International Corporation. San Diego: SEACO.

Moore, S.E. and R.R. Reeves. 1993. Distribution and movement of bowhead whales. *In* J.J. Burns, J.J. Montague, and C.J. Cowles (ed), *The bowhead whale*, p. 313-386. *Soc. Mar. Mamm. Spec. Publ.* 2.

Neff, Jerry M. 1990. "Effects of Oil on Marine Mammal Populations: Model Simulations." *In*: *Sea Mammals and Oil: Confronting the Risks*. Eds. Joseph R. Geraci and David J. St. Aubin. San Diego: API, 35-54.

North Slope Borough (NSB). 1981. Commission on History and Culture. Puiguitkaat. 1978 Elder's Conference, 22-26 May, 1978, Barrow, Alaska. Barrow: NSB, 1981.

—. Commission on History and Culture. Qiniqtuagaksrat Utuqqanaat Inuuniagninisiquin (The Traditional Land Use Inventory for the Mid-Beaufort Sea). Barrow: NSB, 1980.

Patenaude, N.J., M.A. Smultea, W.R. Koski, W.J. Richardson, and C.R. Greene. 1997 Draft. Aircraft Sound and Aircraft Disturbance to Bowhead and Beluga Whales During

the Spring Migration in the Alaskan Beaufort Sea. King City , Ontario, Canada: LGL Ltd. Environmental Research Associates, 37 pp.

Philo, M., J.C. George, R. Suydam, T.F. Albert, T. F., and D. Ramey. 1993. Report of Field Activities of the Spring 1992 Census of Bowhead Whales, *Balaena mysticetus*, off Point Barrow, Alaska with Observations on the Subsistence Hunt of Bowhead Whales 1991 and 1992. International Whaling Commission Report 44. Cambridge, England: IWC, pp. 335-342.

Reed, Mark, K. Jayko, A. Bowles, E. Anderson, S. Leatherwood, and M. Spaulding. 1987. Computer simulation of the probability that endangered whales will interact with oil spills. U.S.D.O.I., Minerals Management Service, Alaska OCS Region. 182p.

Reeves, R.R., and E. Mitchell. 1990. Bowhead whales in Hudson Bay, Hudson Strait, and Foxe River Basin: A review. *Naturaliste Canadien (Revue Ecologie Systematique)* 117:25-43.

Reeves, R.R., E. Mitchell, A. Mansfield, and M. McLaughlin. 1983. Distribution and migration of the bowhead whale, *Balaena mysticetus*, in the eastern North American Arctic. *Arctic* 36:5-64.

Rexford, B. 1996. "The Alaska Eskimo Whaling Commission and History of Subsistence Whaling Off Point Barrow 'Nuvuk'." Proceedings of the 1995 Arctic Synthesis Meeting, Anchorage, Alaska, Oct. 1995. OCS Study MMS 95-0065. U.S. Minerals Management Service. Anchorage: USDO, MMS, 1996.

Richardson, W.J., ed. 1987. Importance of the eastern Alaskan Beaufort Sea to feeding bowhead whales, 1985-86. Report by LGL Ecological Research Associates Inc. to U.S. Minerals Management Service. NTIS No. PB 88 150271/AS. 547 p.

Richardson, W.J. 1996. Acoustic effects on bowhead whales: overview. Pp. 107-110 *In: Proceedings of the 1995 Arctic Synthesis Meeting. Sheraton Anchorage Hotel, October 23 to 25, 1995, Anchorage, AK. Prepared for the USDO, MMS, Alaska OCS Region by MBC Applied Environmental Sciences, Costa Mesa, CA. OCS Study MMS 95-0065. 206 p.*

Richardson, W.J. (Ed) 1999. Marine mammal and acoustical monitoring of Western Geophysical's open water seismic program in the Alaskan Beaufort Sea, 1999. 90-day report. LGL Rep. TA2313-2. Rep. from LGL Ltd., King City, Ont., and Greeneridge Sciences Inc., Santa Barbara, CA, for Western Geophysical, Houston, TX, and NMFS, Anchorage, Ak. and Silver Springs, Md. 121 p.

Richardson, W.J. and C.I. Malme. 1993. Man-Made Noise and Behavioral Responses *In: The Bowhead Whale Book, Special Publication of The Society for Marine*

Mammology 2, D. Wartzok. Lawrence, KS: The Society for Marine Mammology, pp. 631-700.

Richardson, W.J., and D.H. Tomson, eds. 1999. Bowhead whale feeding in the eastern Beaufort Sea: update of scientific and traditional knowledge: results of studies conducted in year 2. LGL Limited for USDO, MMS, Alaska OCS Region.

Richardson, W.J., R.S. Wells, and B. Wursig. 1985. Disturbance Responses of Bowheads, 1980-1984. *In: Behavior, Disturbance Responses, and Distribution of Bowhead Whales, *Balaena mysticetus*, in the Eastern Beaufort Sea, 1980-84*, W.J. Richardson, ed. OCS Study, MMS 85-0034. Anchorage, AK: USDO, MMS, Alaska OCS Region, pp. 255-306.

Richardson, W. J., D. B. Fissel, J. R. Marko, J. R. Birch, G. A. Borstad, D. N. Truax, R. Kerr, W. B. Griffiths, D. H. Thomson, B. Wursig, G. W. Miller, D. M. Schell, S. M. Saupe, N. Haubenstock, J. Goodyear, and D. R. Schmidt. 1987. Importance of the Eastern Alaskan Beaufort Sea to Feeding Bowhead Whales, 1985-86. OCS Study MMS 87-0037, Contract no. 14-12-0001-30233. Prepared for the U.S. Department of the Interior Minerals Management Service by LGL, Ltd., Arctic Sciences Ltd., BioSonics, Inc., G.A. Borstad Associates Ltd., and University of Alaska, Fairbanks. Bryan : LGL, Ltd.

Richardson, W. J., C. R. Greene Jr., M. A. Smultea, B. Wursig, J. S. Hanna, W. R. Koski, G. W. Miller, N. J. Patenaude, R. Blaylock, and R Elliott. 1995a. Acoustic Effects of Oil Production Activities on Bowhead and White Whales Visible During Spring Migration Near Pt. Barrow, Alaska--1991 and 1994 Phases: Sound Propagation and Whale Responses to Playbacks of Icebreaker Noise. OCS Study MMS 95-0051, LGL Report TA954, Contract 14-12-0001-30412. Prepared for U.S. Department of the Interior Minerals Management Service, Procurement Operations by LGL, Ltd. and Greeneridge Sciences Inc. N.p.: n.p.,

Richardson, W. John, C. R. Greene, Jr., C. I. Malme, D. H. Thomson, S. E. Moore, and B. Wursig. 1995. Marine Mammals and Noise. San Diego: API, 1995b.

Schell, Donald M. 1998. Habitat usage as indicated by stable isotope ratios. Report to U.S. Minerals Management Service, MMS Contract 1435-01-97-CT-30842. 10 p.

Shapiro, Lewis H., and R. C. Metzner. 1979. Historical References to Ice Conditions Along the Beaufort Sea Coast of Alaska. NOAA Contract 03-5-022-55, Task No. 6. Prepared by Geophysical Institute, University of Alaska Fairbanks. Fairbanks: UAF, 1979.

Shelden, K.E.W. and D.J. Rugh. 1995. The bowhead whale, *Balaena mysticetus*: its historic and current status. *Marine Fisheries Review* 57(3-4):1-20.

Shotts, E. B., Jr., T. F. Albert, R. E. Wooley, and J. Brown. 1990. "Microflora Associated with the Skin of the Bowhead Whale (*Balaena mysticetus*)." *J. Wildlife Diseases* 26.3 (1990): 351-359.

Small, R. J., and D. P. DeMaster. 1995. Alaska Marine Mammal Stock Assessments 1995. NOAA Technical Memorandum NMFS-AFSC-57. Prepared for the U.S. Department of Commerce, National Oceanic and Atmospheric Administration, National Marine Fisheries Service, Alaska Fisheries Science Center. Seattle: USDOC, 1995.

Spies, R.B., S. D. Rice, D. A. Wolfe, and B. A. Wright. 1996. "The Effects of the *Exxon Valdez* Oil Spill on the Alaskan Coastal Environment." Proceedings of the *Exxon Valdez* Oil Spill Symposium. 2-5 February, 1993, Anchorage. American Fisheries Society Symposium 18. Bethesda: American Fisheries Society.

Suydam, R., J.C. George, T.M. O'Hara, and T.F. Albert. 1997. Efficiency of the subsistence harvest of bowhead whales by Alaskan Eskimos, 1973 to 1996 with observations on the 1995, 1996 and spring 1997 subsistence harvests. Report SC/49/AS19 presented to the Scientific Committee of the International Whaling Commission.

Tarpley, R J., R.F. Sis, T.F. Albert, L.M. Dalton, and J.C. George. 1987. Observations on the Anatomy of the Stomach and Duodenum of the Bowhead Whale, *Balaena mysticetus*. *The American Journal of Anatomy* 180:295-322.

Treacy, S. D. 1988. Aerial Surveys of Endangered Whales in the Beaufort Sea, Fall 1987. OCS Study, MMS 89-0030. Anchorage, AK: USDO, MMS, Alaska OCS Region, 141 pp.

Treacy, S.D. 1989. Aerial Surveys of Endangered Whales in the Beaufort Sea, Fall 1988. OCS Study, MMS 89-0033. Anchorage, AK: USDO, MMS, Alaska OCS Region, 101 pp.

Treacy, S.D. 1990. Aerial Surveys of Endangered Whales in the Beaufort Sea, Fall 1989. OCS Study, MMS 90-0047. Anchorage, AK: USDO, MMS, Alaska OCS Region, 104 pp.

Treacy, S.D. 1991. Aerial Surveys of Endangered Whales in the Beaufort Sea, Fall 1990. OCS Study, MMS 91-0055. Anchorage, AK: USDO, MMS, Alaska OCS Region, 107 pp.

Treacy, S.D. 1992. Aerial Surveys of Endangered Whales in the Beaufort Sea, Fall 1991. OCS Study, MMS 92-0017. Anchorage, AK: USDO, MMS, Alaska OCS Region, 92 pp.

Treacy, S.D. 1994. Aerial Surveys of Endangered Whales in the Beaufort Sea, Fall 1993. OCS Study, MMS 94-0032. Anchorage, AK: USDOl, MMS, Alaska OCS Region, 78 pp.

Treacy, S.D. 1996. Aerial Surveys of Endangered Whales in the Beaufort Sea, Fall 1995. OCS Study, MMS 96-0006. Anchorage, AK: USDOl, MMS, Alaska OCS Region, 119 pp.

U.S. Army Corps of Engineers (USACE). 1996. Transcript of Proceedings, Environmental Impact Statement for Beaufort Sea Oil and Gas Development, Northstar Environmental Impact Statement Project, Public Scoping Meeting, Monday, March 25, 1996, Barrow, Alaska. Prepared by Alaska Stenotype Reporters. Anchorage: ASR, 1996.

U.S. Army Corps of Engineers. 1999. Final Environmental Impact Statement. Beaufort Sea Oil and Gas Development/Northstar Project. 7 Vols. Anchorage, AK: U.S. Army Corps of Engineers.

USDOC, NOAA, NMFS. 1999. Endangered Species Act Section 7 Consultation (Biological Opinion) for the Proposed Construction and Operation of the Northstar Oil and Gas Project in the Alaskan Beaufort Sea. Anchorage AK: USDOC, NOAA, NMFS, 75 pp.

USDOl, MMS. 1986. Public Hearings, Official Transcript of Proceedings, Oil and Gas Lease Sale 97, Nuiqsut, Ak. Anchorage, AK: USDOl, MMS, Alaska OCS Region.

USDOl, MMS, Alaska OCS Region. 1987. Chukchi Sea Oil and Gas Lease Sale 109 Final Environmental Impact Statement. OCS EIS/EA, MMS 87-0009. Anchorage, AK: USDOl, MMS, Alaska OCS Region.

USDOl, MMS. 1995. Public Hearing, Official Transcript of Proceedings, Beaufort Sea Sale 144 Draft EIS, Barrow, Ak. Anchorage, AK: USDOl, MMS, Alaska OCS Region.

USDOl, MMS, Alaska OCS Region. 1995. Biological evaluation for threatened and endangered species with respect to the proposed Beaufort Sea oil and gas lease sale 144. Minerals Management Service, Alaska OCS Region, 33 p.

USDOl, MMS, Alaska OCS Region. 1996 Proceedings of the 1995 Arctic Synthesis Meeting, Anchorage, Ak. OCS Study MMS 95-0065. Anchorage, AK: USDOl, MMS, Alaska OCS Region, 216 pp.

USDOl, MMS, Alaska OCS Region. 1996a. Beaufort Sea Planning Area Oil and Gas Lease Sale 144 Final Environmental Impact Statement. 2 Volumes. Anchorage, AK: USDOl, MMS, Alaska OCS Region.

United States Department of the Interior. Minerals Management Service (USDOI, MMS). 1996. Official Transcript, Proceedings of Public Hearing, Draft Environmental Impact Statement for the Proposed Oil and Gas Lease Sale BF in the Beaufort Sea. Kaktovik, Alaska, May 15, 1979. N.p.: n.p., 1979.

USDOI, MMS, Alaska OCS Region. 1997. Alaska Environmental Studies Strategic Plan FY 1998-1999. Anchorage, AK: USDOI, MMS, Alaska OCS Region, Environmental Studies Program.

USDOI, MMS, Alaska OCS Region. 1997 Arctic Seismic Synthesis and Mitigating Measures Workshop, Barrow, AK. OCS Study, MMS 97-0014. Whalers' signed statement. Anchorage, AK: USDOI, MMS, Alaska OCS Region, 170 pp.

USDOI, MMS, Alaska OCS Region. 1997. Beaufort Sea Planning Area, Oil and Gas Lease Sale 170, Draft Environmental Impact Statement. OCS EIS/EA MMS 97-0011. Cooperating Agency: U.S. Environmental Protection Agency, Region 10.: USDOI, 1997.

USDOI, MMS, Alaska OCS Region. 1997. Proceedings of the arctic seismic synthesis and mitigating measures workshop, March 5-6, 1997. Barrow, Alaska. OCS Study MMS 97-0014. Minerals Management Service, Alaska OCS Region, 71 p.

USDOI, MMS, Alaska OCS Region. 1998. Northstar Oil Spill Probability White Paper. 17298-028-220. Unpublished Report, Anchorage, AK: USDOI, MMS, Alaska OCS Region, 18 pp.

USDOI, MMS, Alaska OCS Region. 2001. Liberty Development and Production Plan. Draft Environmental Impact statement. OCS EIS/EA, MMS 2001-0001. Anchorage AK: USDOI, MMS, Alaska OCS Region.

USDOI, MMS, Alaska OCS Region. 1983. Official Transcript, Proceedings of Public Hearing, Draft Environmental Impact Statement for the Proposed Oil and Gas Leasing in the Diapir Field Lease Offering. Assembly Chambers, North Slope Borough Building, Barrow, Alaska, October 24, 1983. N.p.: Akulaw Court Reporting, 1983.

— 1986. Transcript of Proceedings, Draft Environmental Impact Statement for the Proposed Oil and Gas Lease Sale 97 in the Beaufort Sea. Barrow, Alaska, December 08, 1986. Anchorage: Accu-Type Depositions, Inc., 1986.

—1987. Official Transcript, Proceedings of Public Hearing, Draft Environmental Impact Statement Chukchi Sea, Proposed Oil and Gas Lease Sale 109, Barrow, Alaska, April 10, 1987. Anchorage: Accu-Type Depositions, Inc., 1987.

-1990. Official Transcript, Proceedings of Public Hearing, Draft Environmental Impact Statement for the Proposed Oil and Gas Lease Sale 124 in the Beaufort Sea Planning Area, Alaska Outer Continental Shelf. North Slope Borough Conference Chambers, Barrow, Alaska, April 17, 1990. Anchorage: Executory Court Reporting, 1990.

-1995. Official Transcript, Proceedings of Public Hearing, Draft Environmental Impact Statement for the Proposed Oil and Gas Lease Sale 144 in the Beaufort Sea. Assembly Chambers, Barrow, Alaska, November 8, 1995. Anchorage: Executory Court Reporting, 1995.

Ward, J.G. and E. Pessah. 1988. Industry Observations of Bowhead Whales in the Canadian Beaufort Sea, 1976-1985. *In: Port and Ocean Engineering Under Arctic Conditions: Symposium on Noise and Marine Mammals*, J.L. Imm and S. D. Treacy, eds. Fairbanks, AK: The Geophysical Institute, University of Alaska Fairbanks, pp. 75-88.

Woodby, Douglas A., and D. B. Botkin. 1993. "Stock Sizes Prior to Commercial Whaling." *In: The Bowhead Whale*. J.J. Burns, J.J. Montague, C.J. Cowles, (Eds). The Society for Marine Mammalogy. Special Publication Number 2. Lawrence: Allen Press, Inc., 764.

Würsig, Bernd, and Christopher Clark. 1993. "Behavior." *In The Bowhead Whale*. Eds. J.J. Burns, J.J. Montague, C.J. Cowles (eds). The Society for Marine Mammalogy. Special Publication Number 2 Lawrence: Allen Press, Inc., 1993. 157-99.

Zeh, Judith E., C. W. Clark, J. C. George, D. Withrow, G. M. Carroll, and W. R. Koski. 1993. "Current Population Size and Dynamics." *In: The Bowhead Whale*. J.J. Burns, J.J. Montague, C.J. Cowles, (Eds). The Society for Marine Mammalogy. Special Publication Number 2. Lawrence: Allen Press, Inc.

Zhu, Qian. 1996. Studies on the eyes of the Bowhead whale (*Balaena mysticetus*), ringed seal (*Phoca hispida*), and caribou (*Rangifer tarandus*). Ph.D. thesis. 382p. Institute of Oceanology, Chinese Academy of Sciences, Qingdao 266071, Peoples Republic of China.

Zhu, Qian. 1997. Some remarks on the visual system of the bowhead whale (*Balaena mysticetus*). Presented as document SC/49/AS14 to the Scientific Committee of the International Whaling Commission, Monaco. 7p.

Zhu, Qian, D.J. Hillman, and W.G. Henk. 1998. Observations on the muscles of the eye of the bowhead whale (*Balaena mysticetus*). Presented as document SC/50/AS4 to the Scientific Committee of the International Whaling Commission, 1998 meeting.

Zhu, Qian, D.J. Hillman, and W.G. Henk. 1999. Morphological studies of the visual organ of the bowhead whale (*Balaena mysticetus*). Presented as document SC/51/AS14 to the Scientific Committee of the International Whaling Commission, Grenada.

**Fish and Wildlife Service Endangered Species Act, Section 7
Biological Opinion for BP Exploration's Proposed Liberty
Development and Production Plan**



United States Department of the Interior

FISH AND WILDLIFE SERVICE

1011 E. Tudor Rd.
Anchorage, Alaska 99503-6199

IN REPLY REFER TO:

AFES/ESO/NAES

JAN 11 2002

Memorandum

To: Regional Director - Minerals Management Service

From: Regional Director - Region 7 

Subject: Endangered Species Act, Section 7 Biological Opinion for BP Exploration's Proposed Liberty Development and Production Plan

This document transmits the Fish and Wildlife Service's biological opinion based on our review of the proposed Liberty Development Project located in the Beaufort Sea on the North Slope of Alaska, and its effects on Steller's eiders (*Polysticta stelleri*) and spectacled eiders (*Somateria fischeri*) in accordance with section 7 of the Endangered Species of 1973, as amended (16 U.S.C. 1531 et seq.). Your February 26, 2001, request for formal consultation was received on February 28, 2001, with additional materials received on March 12, 2001.

This biological opinion is based on information provided in the February 26, 2001, biological assessment, the January 2001 draft Environmental Impact Statement, comments received in response to the draft biological opinion circulated in July 2001, and other sources of information. On January 3, 2002, we forwarded the draft biological opinion to your office for your review and comment. On January 9, 2002, we received via facsimile your memorandum indicating that you had no additional comments and requesting that we finalize the biological opinion. A complete administrative record of this consultation is on file at the Northern Alaska Ecological Services Field Office, 101 12th Avenue, Box 19, Fairbanks, Alaska 99701. A chronology of the consultation history is provided in the Attachment.

The incidental take statement for this non-jeopardy opinion includes reasonable and prudent measures and terms and conditions, which are mandatory for the Minerals Management Service to implement. These reasonable and prudent measures, and implementing terms and conditions address take from possible oil spills and migrants colliding with structures on the island.

Although there is a limited degree of interdependency between the proposed action and oil-tankering activities, we have elected to address the effects of oil-tankering on listed species/critical habitat under a separate consultation with the U.S. Coast Guard in recognition of their separate statutory authority relative to tankering activities.

If you have further questions or comments regarding the biological opinion, please have your staff contact Patrick Sousa, Field Supervisor, Northern Alaska Ecological Services Office, at (907) 456-0327.

Attachment

Biological Opinion
for the Proposed Liberty Development Project

Prepared by:

U.S. Fish and Wildlife Service
Northern Alaska Ecological Services
101 12th Ave., Box 19, Room 110
Fairbanks, Alaska 99701

January 2002

TABLE OF CONTENTS

EXECUTIVE SUMMARY	3
DESCRIPTION OF THE PROPOSED	
ACTION AND ALTERNATIVES CONSIDERED	3
Project Overview	3
Proposed Action Area	5
Proposed Construction Activities	5
Liberty Island Design and Construction	5
Pipeline Construction	7
Pipeline Design and Leak Detection	7
Trenching and Installing Pipeline	8
Backfilling Pipeline Trench	9
Landfall and Onshore Pipeline Installation	10
Drilling and Production Activities	10
Transportation During Construction, Drilling and Production Phases	12
Ice Road Construction and Use	12
Helicopter Use	12
Barge and Marine Vessel Use	13
Disposal of Wastes Generated During Drilling, Production and Operations	13
Oil Spill Response Activities	15
Liberty Oil Field Abandonment	16
Other Alternatives Considered	16
STATUS OF THE SPECIES	16
Steller's Eider	16
Status of the Species	16
Species Description	17
Life History	17
Habitat and Distribution	18
Population Size	19
Status and Distribution	19
Analysis for Status of the Species/Critical Habitat	20
Spectacled Eider	20
Status of the Species	20
Species Description	20
Life History	21
Habitat and Distribution	22
Population Size	25
Status and Distribution	25

Analysis for Status of the Species/Critical Habitat 27
 Environmental Baseline 27
 Status of the Species Within the Action Area 28
 Factors Affecting the Species
 Environment Within the Action Area 28
 Effects of the Action on Spectacled Eiders 29
 Oil Spills 29
 Collisions with Structures on Liberty Island 33
 Helicopter Overflights 36
 Barge and Other Marine Vessel Transport 37
 Enhanced Predator Populations 38
 Habitat Loss 38
 Cumulative Effects 39
 Conclusion for Spectacled Eiders 39

INCIDENTAL TAKE STATEMENT 40
 Amount or Extent of Take Anticipated 41
 Oil Spills 41
 Collisions with Structures on Liberty Island 41
 Effect of the Take 42
 Reasonable and Prudent Measures for Spectacled Eiders 42
 Terms and Conditions for Spectacled Eiders 42
 Coordination of Incidental Take Statements
 with Other Laws, Regulations, and Policies 44
 Reinitiation Notice 44

LITERATURE CITED 45

BIOLOGICAL OPINION

EXECUTIVE SUMMARY

British Petroleum Exploration, Alaska (BPXA), proposes to develop and produce oil and gas from the Liberty oil field and has applied to the Minerals Management Service (MMS) for approval of the Liberty Development and Production Plan. The Liberty project is about 5 miles offshore, between the McClure Islands and the coast, and nearly midway between Point Brower to the west and Tigvariak Island to the east. This biological opinion evaluated the impacts of the proposed Liberty project to the threatened Alaska-breeding population of Steller's eiders and the threatened spectacled eider. Based on the best scientific information available, the Service has determined that the likelihood that Steller's eiders occur in the Liberty project area is very low and that no take is anticipated. Additionally, no designated critical habitat lies within the action area of the proposed project. Therefore, we have determined that the Liberty project is not likely to adversely affect either Steller's eider or its designated critical habitat.

The Service has determined that spectacled eiders are found within the project area and that they are likely to be adversely affected by the Liberty Development Project. Potential direct and indirect adverse effects of the proposed action on spectacled eiders include: oil spills, collisions with structures on Liberty island, helicopter overflights, barge and other marine vessel transport, enhanced predator populations, and habitat loss. After reviewing the current status of spectacled eiders, the environmental baseline for the action area, the effects of the proposed project and the cumulative effects, it is the Service's biological opinion that the proposed Liberty project is not likely to jeopardize the continued existence of spectacled eiders. No critical habitat has been designated near the project area; therefore, none will be affected. The Service anticipates that up to 17 birds out of an estimated population of 7,000 on the North Slope may be incidentally taken as a result of the proposed project. This estimate includes 2 mortalities resulting from oil spills and up to 15 from collisions occurring over the course of the 15 year project. The Service has included reasonable and prudent measures and terms and conditions in this biological opinion that are designed to minimize take of spectacled eiders from these threats.

DESCRIPTION OF THE PROPOSED ACTION AND ALTERNATIVES CONSIDERED

Project Overview

The Liberty Prospect is in Federal Outer Continental Shelf (OCS) waters of Foggy Island Bay in the Beaufort Sea northeast of Prudhoe Bay's oil fields. The lessee, British Petroleum Exploration, Alaska (BPXA), proposes to develop and produce oil and gas from the Liberty oil field and has applied to the Minerals Management Service (MMS) for approval of the Liberty Development and Production Plan. The Liberty project is about 5 miles offshore, between the McClure Islands and the coast, and nearly midway between Point Brower to the west and

Tigvariak Island to the east. As a result of BPXA's proposal, the MMS has prepared a Draft Environmental Impact Statement (DEIS), with the U.S. Army Corps of Engineers (COE) and the Environmental Protection Agency (EPA), as formal cooperating agencies. Participating agencies include the Service, the National Marine Fisheries Service (NMFS), the State of Alaska, and the North Slope Borough. This biological opinion is based on the preferred alternative that is identified in the DEIS dated January 2001.

The BPXA proposes to develop the Liberty oil field from a self-contained facility on a manmade gravel island inside the barrier islands in Foggy Island Bay. If the project is approved, the island would be constructed in water about 22 feet deep. The BPXA proposes to begin constructing ice roads in November or December of Year 1, and the gravel island in Year 2. The infrastructure module and the process modules would be sealifted to the island in July/August of Year 2 and Year 3, respectively. The BPXA would conduct development drilling from the first quarter of Year 3 to the first quarter of Year 5 (using diesel-powered generators until production facilities are completed and operational). Approximately 14 production wells, 8 injection wells, and 1 disposal well would be drilled. Oil production is expected to begin in the fourth quarter of Year 3 with an estimated field life of 15 years.

A 12-inch oil pipeline would be constructed in Year 3 and buried in a trench from the island to an onshore landfall. The pipeline would be connected to the recently constructed pipeline for the Badami development project at a proposed gravel pad located south of Liberty island, about 1.5 miles west of the Kadleroshilik River. The total pipeline length would be approximately 6.1 miles, with about 4.6 miles located offshore. Vertical support members would support the aboveground pipeline from the landfall to the Badami pipeline. Oil from Liberty would be transported to Valdez, Alaska through the Trans-Alaska Pipeline System and carried by tanker to ports along the U.S. west coast or to Far East countries.

Transportation to the project area primarily would be by ice roads and helicopter in the winter, helicopter and boats during the open-water period, and helicopters during the broken-ice period in the spring and fall. Except for the two sealifts, aircraft and vessels will travel shoreward of the McClure Islands to lessen potential conflicts with subsistence whaling.

After the field is depleted, BPXA would plug and abandon the wells and remove production and other surface facilities. At a minimum, the portion of the pipeline contained in the island would be removed. The decision to remove the subsea pipeline would be based on an evaluation made of the impacts of the options at the time of abandonment. Based on conditions at the time, including relevant permit stipulations, laws, regulations, and policies, BPXA would develop a detailed abandonment plan for agency review and approval. A likely scenario for island abandonment would involve removing island facilities and slope protection, including gravel-filled bags, and allowing the island to erode naturally. The onshore portion of the pipeline, the vertical support members, and other surface equipment would be removed. Abandonment of the landfall and Badami tie-in gravel pads will be determined at that time.

Proposed Action Area

The proposed action area would include Liberty Island located in Foggy Island Bay, the offshore and onshore pipeline corridor, landfall pad, tie-in pad, and the gravel mine. The action area would also include areas that could be impacted through indirect effects of the proposed action such as impacts to habitat as a result of oil spills and altered prey communities because of destruction of marine benthic habitat for construction of the island and offshore pipeline. The entire extent of the area that could be affected by indirect effects is unknown but is expected to encompass offshore and onshore areas within the eastern Prudhoe Bay region.

Proposed Construction Activities

Liberty Island Design and Construction

The proposed Liberty gravel island would be constructed in 22 feet of water. The island is designed to provide adequate space for development wells and production and other facilities. The buried portion of the Liberty pipeline would be connected through a tie-in to the Badami pipelines. A helicopter landing pad and dock would be available for access by helicopters and vessels. Ice roads would provide seasonal vehicular access to the island. The island has been designed to withstand the environmental conditions expected at the proposed location. The proposed dimensions of the island are:

- working surface - 345 feet by 680 feet
- bottom dimension - 635 by 970 feet
- working surface elevation - 15 feet above sea level
- perimeter berm elevation - up to 23 feet above sea level, which would be 8 feet above the working surface
- footprint at the sea floor - maximum of 835 feet by 1,170 feet (22.4 acres)

The island would be constructed with the following materials:

- 773,000 cubic yards of gravel fill
- filter fabric placed from the top of the island slope to the sea floor
- 4,200 polyester gravel bags (4 cubic yards each) placed 7-23 feet above sea level on the upper slope of the island (17,000 cubic yards gravel)
- interlinked concrete mats, constructed of concrete blocks requiring 7,600 cubic yards of gravel, placed from the base of the gravel bags to the sea floor
- total gravel = 797,600 cubic yards
- steel sheetpile around an approximate 150-foot by 160-foot dock/helipad area

The proposed working surface elevation of 15 feet was selected to ensure that the elevation of the island is higher than the potential height of wave or ice-rideup events for a 100-year return period. The total mass of the island (gravel fill and production facilities) is intended to provide

sufficient resistance to lateral movement under maximum ice loads. A gravel bench, which extends more than 40 feet from the base of the gravel bags to the sea surface, would dampen wave energy approaching the island and induce natural formation of ice rubble.

Gravel bags would be used in the upper portion of the island slope starting 7-8 feet above sea level and continuing to the top of the berm. This would provide additional frictional resistance in the unlikely event of ice ride up past the 40-foot bench. The gravel bags are only used in the upper portion of the island to avoid direct forces from ice or wave action, to minimize potential damage and dislocation, and to protect the surface of the island from the unlikely event further ice ride up occurs. The gravel bags would be made of a polyester material that is heavy and would sink in seawater. This material is about four times stronger than the polyethylene bags used in the 1980's construction of exploration drilling islands. Interlinking concrete mats would be placed on the lower slope of the island from the base of the gravel bags down to the sea floor to provide stability and protection against erosion. Filter cloth material placed underneath the gravel bags and concrete matting would prevent the gravel fill material from washing out.

The oblong shape of the island would be oriented so that the smaller dimension of the island is facing north to lessen exposure to potential ice and wave forces. Production modules and the well bay would be positioned towards the center of the island to further minimize potential exposure to ice override onto the working surface of the island. The surface of the island would be contoured so that runoff flows into sumps away from production facilities.

The BPXA proposes winter season construction of Liberty Island and related pipelines, using an ice road from the gravel mine at the Kadleroshilik River to the island site. The BPXA proposes to start constructing the ice road in December of Year 1, so they can access the mine site, haul gravel, and construct the island. The ice-road system would be reconstructed in December of Year 2 to support pipeline construction.

Workers would start developing the Kadleroshilik River mine site in January of Year 2 for construction of the gravel island. Mining operations would continue in Year 3 to support pipeline construction activities. The proposed mine site is approximately 31 acres, located about 1.4 miles south of Foggy Island Bay. The BPXA has estimated the proposed site is about 40% dry dwarf shrub/lichen tundra, 10% dry barren/dwarf shrub, forb, grass complex, and 50% river gravel. Developing the mine site would include:

- Removing snow and ice.
- Removing and stockpiling up to 100,000 cubic yards of unusable material.
- Excavating the pit and hauling gravel.
- Backfilling unusable material into the pit.
- Maintaining a dike approximately 50 feet wide between the mine site and the river channel while mining operations are under way.
- Flooding the pit to reclaim the site. The flooded mine site would create potential fish overwintering habitat.

Gravel would be transported over the ice road for about 45-60 days, and is expected to be in place at the island construction site by the end of April of Year 2. The gravel-placement process involves using conventional ditch-witches and backhoes to cut and remove blocks of ice from the construction site. The hole left by the removed ice blocks is enlarged and filled with gravel that is hauled in by conventional belly-dump trucks. This process continues until the total volume of gravel-fill material has been placed, including excess gravel necessary to fill the number of gravel bags to be used for slope protection. Once the majority of the island is completed, materials for foundations and sheetwalls would be transported to the island by ice road or by barge.

Once the gravel fill is in place, workers would work through breakup to grade and reshape the island to the final design. Following breakup, and continuing into July, the filter cloth and slope protection (concrete mats and gravel bags) would be installed. Gravel bags would be filled from excess gravel at the island construction site. By the end of May, the pile-driven sheetwall for the dock would be installed, followed by installation of the concrete foundations. Foundation installation would take about 30 days and be completed by mid-August. All remaining island construction work would be completed in early to mid-August before the sealift arrives in Year 2.

The mine site would contain a reserve area with enough gravel to build a separate, smaller island, should an emergency relief well need to be drilled.

Pipeline Construction

The proposed offshore pipeline route would go nearly straight from Liberty Island to a landfall about 4.6 miles to the south-southwest. The overland route would be about 1.5 miles long and extend south to connect with the proposed Badami oil pipeline about 1.5 miles west of the Kadleroshilik River. The overland route would avoid major lakes and intersect the Badami pipeline at a new gravel pad. Pipeline construction is planned for winter of Year 3, starting in January and ending by May. The pipeline system would be placed during the winter within a temporary right-of-way (250 feet wide onshore, 1,500 feet wide offshore). For welding strings of offshore pipeline, a 6,000 feet long by 750 feet wide welding pad would be constructed close to shore on grounded sea ice.

Pipeline Design and Leak Detection System

The BPXA proposes a single-wall steel pipeline system consisting of a 12.75-inch outside diameter pipe with a 0.688-inch wall thickness. The BPXA proposed to install several types of leak-detection systems along the pipeline. The pressure-point analysis and mass-balance line-pack compensation system has been used extensively on the North Slope and is considered as part of the best available and safest technology. Pressure-point analysis is the continuous monitoring of the pipeline to detect pressure variances resulting from leaks and variances in measured volumes of oil at the inlet and outlet of the pipeline. Mass-balance line-pack compensation measures the volumetric throughput at both the island and the Badami tie in. The accuracy of the meters would be such that the threshold for the leak-detection system would be

0.15% of flow. If there are volume discrepancies without an apparent operational reason, the pipelines would be temporarily shut in until the problem was resolved.

The BPXA also plans to incorporate the Leak-Detection and Location System (LEOS), or an alternative but equivalent system, as part of the leak-detection system for the pipeline. The LEOS leak-detection system detects leaks by means of a low-density polyethylene tube, which is highly permeable to oil and gas molecules. The tube is pressure tight and contains air at atmospheric pressure when installed. In the event of an oil leak, some of the leaking oil diffuses into the tube due to the concentration gradient. The air in the tube is tested every day, when a pump at the island pulls the air at a constant speed through the tube into a detector unit. The detector unit is equipped with semiconductor gas sensors that can detect very small amounts of hydrocarbons. The LEOS system can detect a leak when the total volume of the leak reaches 0.3 barrels within 24 hours. The LEOS system has been installed in underground pipelines and in aquatic environments, mostly in Europe. It also has been installed as part of the Northstar pipeline leak-detection system, although its long-term effectiveness in the Arctic has not been demonstrated. A contingency plan has been developed should the LEOS system become inoperable during the period of solid ice when visual detection of a leak cannot be performed.

Automated pipeline isolation valves for the sales oil pipeline would be located on Liberty Island and at the landfall and the Badami pipeline tie-in point. The landfall gravel pad will be approximately 135 feet by 97 feet (0.3 acres), requiring approximately 2,400 cubic yards of gravel.

Trenching and Installing Pipeline

The pipeline would be constructed during the winter through the ice. Ice roads would be constructed to provide transportation routes and the sea ice will be thickened to support pipeline construction activities. After the ice is sufficiently thick, a slot would be cut through the ice to allow the pipeline trench to be dug. Trenching would use conventional excavation equipment, such as backhoes. Hydraulic dredging may be used for final smoothing of the trench bottom. The pipeline would be welded together on the ice surface and then lifted from the ice and placed in the trench. The offshore pipeline would be buried in a trench with a minimum buried depth of 7 feet. A pull tube would be placed in the island to transition the pipelines as they approach Liberty island's working surface. The volume of dredged/excavated material removed from the trench between Liberty island and the shoreline is estimated to total about 724,000 cubic yards. Most of the material would be backfilled into the trench.

Near the coastline, the pipeline would begin a transition from being buried to being elevated. The onshore transition point of the trench would be about 150 feet landward of mean low-lower water to provide sufficient protection from coastal erosion expected during the life of the pipeline plus a safety factor.

Backfilling Pipeline Trench

Approximately 17,000 cubic yards of gravel fill would be required as pipeline-bedding material at various locations within the trench between the island and the 3-mile limit, and 50,000 cubic yards shoreward of this point. These estimates include 16,000 cubic yards of gravel contained in 4,000 geotextile bags placed across the pipeline at regular intervals that provide the additional weight necessary to prevent the vertical movement of the pipeline during thermal expansion to the operating temperature of 150 degrees Fahrenheit. The bags would cover approximately 50% of the pipeline route. They would be buried below the sea floor by backfill material and would not be exposed to ice or erosional forces.

The pipeline trench would be backfilled with the material removed during excavation of the trench. Between the Liberty Island and the 3-mile limit, approximately 162,000 cubic yards of trench-dredged material would be used as backfill. Between the 3-mile limit and the shoreline, about 495,000 cubic yards of backfill material would be used. A minimum of 7 feet of fill material would cover the pipeline. In water up to 8 feet deep, the cap of the backfill would not exceed that of the original sea floor grade by more than 1 foot. In water deeper than 8 feet, the trench cap would not exceed 2 feet higher than the surrounding sea floor. During trenching, the trench material would be stored temporarily on the ice surface near the trench. Any portions of this material that freeze would be broken up into smaller pieces prior to replacement in the trench. If trenching, installing the pipeline, and backfilling occur simultaneously as part of a continuous operation, the native backfill material would be returned to the trench almost immediately. The backfill is used to help control upheaval buckling and also to help protect the pipeline from external damage. The rate of backfilling is limited by the rate of pipeline installation, which is constrained by the rate of excavation. Backfilling is estimated to require 36 days. The affected footprint would be 18.2 acres beyond the 3-mile limit and 55.2 acres within the 3-mile limit including the trench cap, which could exceed the limits of the trench excavation.

Any dredged/excavated material that would result in over mounding if placed back into the trench would require disposal into ocean water. The amount of mounding would not affect pipeline integrity but would be an environmental concern. Two locations are designated for temporary storage (on the ice surface) and as disposal sites of excess dredged materials.

Zone 1 would be located on the west side of the pipeline right-of-way on grounded sea ice outside the 5-foot isobath. Maximum dimensions of the site would be 5,000 by 2,000 feet (230 acres). Zone 1 would serve as the primary temporary storage location of all excavated materials that cannot be directly transported for backfill along the pipeline. Also, excess trench material that cannot be used as backfill would be transported to this zone as the primary and preferred ocean disposal site. Excess trench material placed in Zone 1 would be groomed to a height not to exceed 1 foot above the sea floor to minimize the potential for mounding. Material would be stacked on portions of the site over deeper water first and then over shallower water. The

maximum quantity of spoils stockpiled or left for disposal on this site at any one time would not exceed 100,000 cubic yards. Assuming this maximum quantity is placed in stacks 1 foot high, about 27% of Zone 1 (about 62 acres) would be used for actual disposal.

Zone 2 is a 200-foot-wide section along the west side of the pipeline trench from the island to shore. About 24,400 feet of Zone 2 would be shoreward of the 3-mile limit and 8,000 feet is seaward. Zone 2 would be an alternate temporary on-ice storage area, and the contingent disposal location for excess trench materials. The maximum quantity of excess trench materials stockpiled or left for disposal on this site at any one time would not exceed 10,000 cubic yards. Excess trench material in Zone 2A (water depth less than 16 feet) normally would be stacked or groomed to maintain an approximate elevation of less than 1 foot above the sea floor. Excess trench material placed in Zone 2B (floating ice over water greater than 16 feet deep) would be stacked or groomed to a height not to exceed 2 feet. The BPXA intends to clear Zone 2 of all excess dredged material/spoils by spring breakup by scraping the ice with heavy equipment.

Landfall and Onshore Pipeline Installation

The onshore portion of the pipelines would be elevated at least 5 feet above the tundra and have polyurethane-foam insulation and L-shaped expansion loops placed approximately 3,300 feet apart. The Liberty-Badami pipeline tie-in pad would be approximately 170 feet by up to 155 feet, requiring approximately 3,500 cubic yards of gravel.

The transition of the pipeline from offshore to onshore (i.e. from buried to elevated) would begin approximately 100 feet offshore and extend on land about 150 feet from shore. The transition trench would be backfilled with 2,500 cubic yards of thaw stable gravel material. The 0.3 acre onshore transition area would be capped with 400 cubic yards of native overburden excavated from the site.

Drilling and Production Activities

Drilling activities would start in February of Year 3, beginning with the waste-injection well. After an adequate number of wells are drilled, production will begin. During production, drilling would continue until the reservoir is developed.

Drilling Activities:

- Start drilling using diesel-generated power until electrical power from the plant is available.
- Start development drilling in February of Year 3 and finish in February of Year 5.
- Drill at least 23 wells: 1 disposal, 14 producing, 6 water injection, and 2 gas injection wells, at a wellhead spacing of 9 feet.

- Drill the disposal well first. Muds and cuttings from the disposal well initially will be stored onsite and then injected into a disposal well. As an alternative, these wastes may be hauled to existing disposal facilities onshore. Muds and cuttings from subsequent development wells will be injected down the disposal well.
- Drill production and injection wells in specific sequence and as necessary to ensure the reservoir is depleted in the most efficient way.
- Conduct workover operations (operations conducted in the well bore to improve the performance of the well) periodically and as necessary.

Production Activities:

- Drilling would start using diesel-generated power.
- Use produced gas for fuel following completion of the first development well.
- Start production in Year 4; the economic field life currently is estimated to be approximately 15 years; the facilities/pipeline have a minimal operational economic life of 20 years.
- Start production at 30,000-35,000 barrels per day, rapidly increasing to the plateau production rate of 65,000 barrels per day, with possible intermittent production rates of up to 75,000 barrels per day to maintain the average production level. Peak production of 65,000 barrels per day would be expected to be reached by Year 3 and continue for 3 years, followed by a steady decline until abandonment.
- Start waterflood and gas reinjection in the early life of the field to maintain the reservoir pressure and maximize oil recovery.
- Use produced water and seawater in waterflood injection. Up to 86,000 barrels per day of seawater would be drawn and treated at the site for injection.
- Inject a portion of the produced gas for pressure maintenance (artificial lift).
- Discharge treated seawater and other waste management.

Although only 23 wells are proposed to develop the target reservoir, the Liberty gravel island is designed to accommodate up to 40 well slots. These well slots provide for contingency drilling, should any of the original wells become unusable during the life of the project. As information on the reservoir performance is evaluated during the life of the project, additional wells may be determined necessary to properly develop the target reservoir. The BPXA also indicated that appraisal wells may be drilled in the future to assess the potential for other productive formations. Any production resulting from additional wells into the target formation or other productive formations would be processed through the existing facilities and pipeline. No additional processing facilities, pipelines, or structures are proposed or anticipated to accommodate potential future production. Additional future production, if any, could extend the operating life of the Liberty island, processing equipment, and pipelines and would be subject to environmental assessment at that time.

Transportation During Construction, Drilling and Production Phases

Ice Road Construction and Use

Ice roads would be built through the life of the project to provide vehicle access to the island during solid-ice conditions. During Liberty construction (starting in December of Year 1 and continuing through project startup in November of Year 3), offshore and onshore ice roads will provide winter access for constructing the island and pipeline. During construction, ice roads would extend in corridors:

- along the coast from the Endicott Causeway to the shore-crossing location in Foggy Island Bay,
- from the gravel island to the Badami pipeline,
- from Point Brower to the gravel island, and
- from the Kadleroshilik River mine site to the gravel island.

Additional spur roads may be constructed to interconnect the major corridors. Trunk roads built on grounded sea ice and onshore would have a travel surface approximately 40 feet wide. The road from the mine site to the gravel island would be about 50 feet wide. Typically, ice roads constructed on the tundra would be 6 inches thick. Offshore, the ice roads would need to be sufficiently thick to support the construction equipment that would be using the road. The ice would be thickened to about 8 feet in the offshore floating ice zone. In Year 4 and following, segments of ice roads would be built to support drilling and production operations on the island.

Up to 400 round trips over the roads are forecast daily during winter construction and 400 round trips for each season during drilling. After drilling, this number would drop to 100 each season.

Helicopter Use

Helicopters generally would be used to transport personnel and food and for the emergency transport of supplies or equipment year-round. Helicopters would fly at an altitude of at least 1,500 feet except for takeoffs and landings and when safety is an issue.

The BPXA estimates 10-20 daily helicopter flights during the construction phase of the project. During the operation/production phase, helicopter flights would be reduced to 3 trips per week during the summer and winter and a daily trip during breakup. Fixed-wing aircraft also may be used for aerial surveillance. Helicopters or vessels would handle emergency evacuations, based on a detailed plan that BPXA would complete before operations begin. During production,

BPXA plans to use helicopters at least once a week to survey offshore and onshore pipelines. Helicopter visits to the tie-in pad should average no more than once a week for routine operations.

Barge and Marine Vessel Use

Seagoing barges would carry large modules and other supplies and equipment from Southcentral Alaska. Barges would be in the Point Barrow area only from mid-August through mid- to late September and will dock at the island to offload modules. Vessels from Prudhoe Bay or Endicott would travel shoreward of the barrier islands to lessen conflicts with subsistence users. An estimated 150 local round trips by marine vessels plus 2 sealifts could occur during the construction phase. The number of round trips would be reduced to 4-5 trips per season during the operation/production phase. Vessel traffic outside the barrier islands, except for emergencies, would be scheduled to avoid interference with subsistence whaling.

Disposal of Wastes Generated During Drilling, Production and Operations

The BPXA proposes to use a waste-disposal underground-injection well for the management of waste products generated by drilling, production, and operational activities associated with the Liberty Project. The disposal well is designed to meet Environmental Protection Agency Class I industrial waste-disposal well standards. The waste stream, as defined by the Resource Conservation and Recovery Act, would consist of all exempt and nonexempt nonhazardous waste materials. The waste-disposal well would be the first well permitted; it is the key component in BPXA's environmental waste-management plan for handling waste products.

The majority of wastes generated during construction and development drilling would be drill cuttings and spent muds. Some waste also would be generated during operations from well-workover activities. These drilling fluids would be disposed of through onsite injection into the disposal well or would be transported offsite to permitted disposal wells. The BPXA proposes zero discharge of drilling waste to lessen discharges into the Beaufort Sea. The BPXA would dispose of cuttings in onsite or offsite disposal wells. Onsite, they would run cuttings through a portable grinding unit and inject them into the disposal well with spent muds. Cuttings taken offsite would go through the grinder and into a permitted disposal well at Prudhoe Bay. Drilling wastes, including those from the first wells, would remain in temporary storage onsite until disposal. Produced waters would be reinjected.

In addition to drilling wastes, domestic wastewater and solid waste would be generated during the project. Workers at the site would haul burnable and recyclable scrap, including scrap metal, to an approved location. Nonhazardous solid waste (trash, food wastes, construction debris) would be either burned onsite, with the ash hauled ashore, or hauled to an approved offsite disposal facility.

The BPXA would chlorinate effluent from the unit and place it in the injection-well waste stream. The BPXA has applied to the Environmental Protection Agency for a National Pollutant Discharge Elimination System permit to discharge effluent from sanitary and domestic wastewater into the sea whenever the injection well is unavailable. Under the waste-management plan, BPXA does not plan to discharge domestic waste effluent or storm water (coming from rain and snowmelt collected in the surface sumps) to the sea. However, to ensure compliance with any potential waste-management-discharge scenarios, BPXA would acquire an Environmental Protection Agency National Pollution Discharge Elimination System permit for discharging these and other wastes. An outfall line would be used for the out flow from the “reject stream” of the Seawater Treatment Plant, the backwash from the desalination unit, treated domestic wastewaters, and water used to test fire-protection and suppression systems.

Wastes shipped offsite would be transported over ice roads in winter or shipped on barges or boats in summer. During spring and fall breakup and freeze up when transportation by ice road or barge is not available, waste products would be stored in appropriate containers until workers can haul them to other locations for disposal.

The quantity of waste materials for disposal in the injection well would be about 6,000,000 barrels for the 15-20 year life of the Liberty project including:

- 700,000 barrels of rig muds and other liquids
- 70,000 barrels of rig drill cuttings and other solids
- 100,000 barrels of flush waters for cuttings disposal
- 900,000 barrels of camp sewage and gray water
- 2,700,000 barrels of wastes from wells, processing units, etc.
- 1,500,000 barrels of storm-water runoff
- 20,000-40,000 barrels of nonhazardous industrial wastes

The relative waste volumes of the injection well are:

- 44% industrial waters consisting of seawater, brine from produced oil reservoirs, freshwater, and water gel
- 12% water-based drilling mud
- 1% water-based drill cuttings
- 15% domestic wastewater (camp sewage)
- 25% storm water
- 3% well-workover fluids, crude oil, vessel sludge/sand, diesel, methanol
- less than 1% spent acid, cement, agents used to fracture formations, and other minor waste streams
- less than 1% nonhazardous industrial wastes

Oil Spill Response Activities

The Federal Oil Pollution Act of 1990 and the State of Alaska AS 46.04.030 and 18 AAC 75 require the owner or operator of an oil exploration or production facility to prepare an Oil Discharge Prevention and Contingency Plan (ODPCP, or C-Plan). The Liberty C-Plan, submitted in January 1998, identifies the planning, equipment, personnel, and training needed to satisfy the oil spill response requirements outlined by State and Federal regulations. The plan must be reviewed and finalized by the Alaska Department of Environmental Conservation, MMS, EPA, U.S. Department of Transportation, and the U.S. Coast Guard (USCG). The C-Plan must be regularly updated (at least every 6 months) to reflect changes in operations, response capabilities, emergency response contact names and phone numbers, or any other information that would affect oil spill prevention and response activities.

The general response procedures include:

- Containment using snow berms or booms.
- Mechanical recovery to the extent possible and burning to aid recovery of spilled oil in open water and broken ice conditions.
- Temporary storage of fluids recovered from a large oil spill in on-site tanks or at other onshore sites in Deadhorse, Prudhoe Bay, and Endicott.
- Protection and cleanup of environmentally sensitive areas and areas of public concern such as cultural resource sites, public use areas, native allotments, and bird nesting areas. Regional Contingency Field Maps included in the ODPCP identify these areas of concern, with the exception of archaeological sites. Strategies for protection and cleanup of these areas would be developed based on the data contained in these contingency maps. The reviewing agencies have the authority to define and prioritize the environmentally sensitive areas.
- A waste disposal method which will be determined by the Operations Chief in consultation with the Environmental Unit Leader at the time of the spill.
- Wildlife protection starting with notification of trustee agencies. Strategies for protecting wildlife include containment of oil before it is encountered by wildlife; hazing wildlife from oiled areas; capture, stabilization and treatment/transport of birds; and collecting any oiled or dead wildlife to avoid contamination of mammals and birds through scavenging. Passive hazing techniques for birds could be utilized such as balloons, scarecrows, and mylar tape as well as active hazing programs such as aircraft and boat herding or hazing, propane cannons and alarms, electromagnetic current or chemical deterrents.
- Salvage of dead oiled birds and mammals. Attempts will be made to collect dead specimens quickly to prevent secondary contamination of scavengers and to provide specimens for research. Carcasses will be taken to the North Slope Stabilization Center for storage.

Liberty Oil Field Abandonment

After the field is depleted, BPXA would plug and abandon the wells and remove production and other surface facilities. At a minimum, the portion of the pipeline contained in the island would be removed. The rest of the subsea pipeline may be removed or abandoned in place after an evaluation is made of the impacts of the options at the time of abandonment. Based on conditions at the time, BPXA would either remove the gravel or let the island erode naturally. The gravel bags used for island slope protection would be removed at the same time that other island abandonment activities take place, in keeping with regulations and permit requirements in force at the time of project abandonment. The onshore portion of the pipeline, the vertical support members, and other surface equipment will be removed. The landfall and Badami tie-in gravel pads will be abandoned in place.

Other Alternatives Considered

Section II of the Liberty Draft EIS describes the alternatives being considered by decision-makers to choose one of the following options: approve the project as proposed, disapprove the project, or approve a modified version of the project. The project description presented in the preceding pages of this BO would be associated with the first option. A no-action alternative would be associated with the second option, and the third option is addressed in five sets of “component alternatives.” The sets of component alternatives are:

- alternative drilling and production island locations and pipeline routes for which there are three potential choices: Liberty Island location and pipeline route (as proposed), Southern Island location and Eastern pipeline route, and Tern Island location and pipeline route;
- alternative pipeline designs for which there are four potential choices: single walled steel pipe (proposed); steel pipe-in-steel pipe, steel pipe-in HDPE (plastic), and flexible pipe;
- alternative upper island slope protection systems for which there are two potential choices: gravel bags (proposed) and steel sheetpile;
- alternative gravel mine sites for which there are two choices: Kadleroshlik River mine (proposed) or Duck Island gravel mine;
- alternative pipeline burial depths for which there are two choices: a 7-foot burial depth (proposed) or a 15-foot trench depth.

STATUS OF THE SPECIES

Steller’s Eider

Status of the Species

The Alaska breeding population of Steller’s eiders was listed as threatened on June 11, 1997 (62 FR 31748). This determination was based on a substantial decrease in the species’ nesting range

in Alaska, a reduction in the number of Steller's eiders nesting in Alaska, and the resulting increased vulnerability of the remaining breeding population to extirpation. The vast majority of the species' total numbers are individuals that nest in Russia and molt and/or winter in Southwest Alaska; only the population that nests in Alaska is classified as threatened. This biological opinion will evaluate the impacts of the proposed Liberty project to the Alaska-breeding population of Steller's eiders.

The Service designated critical habitat for the Steller's eider (66 FR 8850, February 2, 2001) in breeding habitat on the Yukon-Kuskokwim Delta (YK Delta) and in 4 units in the marine waters of southwest Alaska, including the Kuskokwim Shoals in northern Kuskokwim Bay, and Seal Islands, Nelson Lagoon, and Izembek Lagoon on the north side of the Alaska Peninsula. Since none of these areas are in the vicinity of the proposed Liberty project, we do not anticipate that the project will impact these critical habitat units.

Species Description

The Steller's eider is the smallest of the four eider species. Males in breeding plumage (during spring and summer) have a white head with a greenish tuft, a small black eye patch, a black back, white shoulders, and a chestnut breast and belly with a black spot on each side. Females are mottled dark-brown year-round. Adults of both sexes have a blue wing speculum with a white border.

Life History

Most of what is known of Steller's eider breeding ecology comes from observations made in the vicinity of the village of Barrow. Steller's eiders arrive at Barrow in pairs beginning in early June. Nest initiation dates are typically in the first half of June (Quakenbush *et al.* 1995), and hatching dates range from 7 July to 3 August (Quakenbush *et al.* 1998). After nesting, Steller's eiders return to marine habitats to molt. Concentrations of molting Steller's eiders have been noted in Russia on the Chukchi and Bering sea coasts (Kistchinski 1973), near Saint Lawrence Island in the Bering Sea (Fay 1961), and along the northern shore of the Alaska Peninsula (Jones 1965; Petersen 1980, 1981). Males typically depart the breeding grounds after females begin incubating; near Barrow, this occurs in late June or early July (Quakenbush *et al.* 1995). Small groups of males (less than 10) have been observed in July near shore in the Chukchi Sea near Barrow (L. Quakenbush, pers. comm.), and a flock of 28 females, presumably failed breeders, was observed flying between the Chukchi Sea and a nearshore inlet south of Barrow in early August 1996 (C. Donaldson, Northern Alaska Ecological Services, U.S. Fish and Wildlife Service, pers. comm.). Females and fledged young depart the breeding grounds in early to mid-September. Most Steller's eiders migrate south after breeding to molt along the coast of Alaska from Nunivak Island to Cold Bay, primarily in Izembek and Nelson lagoons and near Seal Island. The majority of Steller's eiders winter in Alaska from the eastern Aleutian islands to lower Cook Inlet.

Habitat and Distribution

The current breeding distribution of Steller's eiders encompasses the Arctic coastal regions of northern Alaska from Wainwright to Prudhoe Bay up to 90 km (56 mi) inland (Fish and Wildlife Service, unpublished data), and Russia from the Chukotsk Peninsula west to the Taimyr, Bydan and Yamal peninsulas (American Ornithologists' Union 1983). The majority of Steller's eiders nest in Arctic Russia (Palmer 1976; Bellrose 1980).

Steller's eiders spend most of the year in marine habitats. During winter, most of the world's Steller's eiders concentrate along the Alaska Peninsula from the eastern Aleutian Islands to southern Cook Inlet in shallow, near-shore marine waters (Jones 1965; Petersen 1980). They also occur in the western Aleutian Islands and along the Pacific coast, along the Asian coast (from the Commander Islands to the Kuril Islands), and some are found along the north Siberian coast west to the Baltic States and Scandinavia (Palmer 1976; Cramp *et al.* 1977). In spring, large numbers sometimes concentrate in the Kuskokwim Shoals area before migration to breeding grounds; in 1992, an estimated 138,000 Stellers's eiders congregated before sea ice conditions allowed movement northward (Larned *et al.* 1994).

Historically, Steller's eiders nested in Alaska in two general regions: western Alaska, where the species has been nearly extirpated, and the North Slope, where the species still occurs. In western Alaska, Steller's eiders occurred primarily in the coastal fringe of the Yukon-Kuskokwim Delta, where the species was common at some areas in the 1920s, was still present in the 1960s, but was not recorded as breeding from 1976-1994 (Kertell 1991; Flint and Herzog, 1999). In 1994 and 1996-1998, 1-2 nests have been located each year at either or both the Tutakoke River and Hock Slough study sites on the Yukon-Kuskokwim Delta (Flint and Herzog 1999).

On the North Slope, Steller's eiders historically occurred from Wainwright east, nearly to the United States-Canada border (Brooks 1915). The species may have abandoned the eastern North Slope in recent decades, but it still occurs at low densities from Wainwright to at least as far east as Prudhoe Bay. Near Barrow, Steller's eiders still occur regularly, though they do not nest annually. In some years, up to several dozen pairs may nest in a few square kilometers.

Nests in Barrow are located in wet tundra, in areas of low-center polygons or low (indistinct flat-centered) polygons, frequently within drained lake basins (Quakenbush *et al.* 1998). Average clutch sizes at Barrow ranged from 5.3-6.3 in five different years (Quakenbush *et al.* 1995; USFWS/NSB, unpublished data). Nesting success at Barrow ranged from 15%-38% in the nesting years 1993 (n=13), 1995 (n=26), and 1996 (n=13) (Quakenbush *et al.* 1995; USFWS/NSB, unpublished data). Egg loss was attributed mostly to predation by avian predators, including jaegers, common ravens, and possibly glaucous gulls and Arctic foxes (Quakenbush *et al.* 1995). Fledging age is estimated to be 37 days (USFWS/NSB, unpublished

data). Broods most often used ponds with emergent grass (Quakenbush *et al.* 1998). Broods were reared close to their nest site; 8 broods tracked near Barrow in 1995 remained within 650 m (2,132 ft) of their nest sites for the first 32 days after hatching (Quakenbush *et al.* 1998).

Population Size

The size of the Alaska breeding population is not known with certainty. Annual aerial surveys sample 2-3% of the suitable waterfowl breeding habitat during which up to several dozen Steller's eiders are detected. Sightings are too few to provide a statistically valid estimate of population size, but extrapolations based on the number of birds seen indicate that hundreds to low thousands may occupy the North Slope. The breeding status of those individuals seen from the air is unknown; the extensive ground surveys that would be necessary to determine breeding status have not been conducted. There are only three recent records of broods from North Slope locations other than Barrow: one in 1997 near the upper Chipp River, approximately 80 km (50 mi) inland from the Dease Inlet/Admiralty Bay area (Fish and Wildlife Service, unpublished data), one in 1992 near Prudhoe Bay (M. Johnson, University of California, Davis, pers. comm.), and one in 1987 along the lower Colville River (T. Swem, Northern Alaska Ecological Services, U.S. Fish and Wildlife Service, pers. comm.).

Status and Distribution

Knowledge of the distribution of Steller's eiders on the North Slope is provided by aerial waterfowl and eider surveys as well as incidental observations made during other studies. Several Steller's eiders were observed in the Prudhoe Bay area during intensive shorebird and eider studies from the early 1980's to the present, although breeding activity was never observed (D. Troy, Troy Ecological Research Associates, Inc. [TERA], pers. comm.).

Aerial waterfowl and eider surveys that sample the entire Arctic coastal plain provide more useful information on the relative distribution of the species across the North Slope. Approximately 305 Steller's eiders were seen during waterfowl breeding pair surveys that sampled approximately 2% of the Arctic coastal plain each year from 1989-1999; one female was seen in the Sagavanirktok River valley but all others seen were west of the Colville River (R. King, Fish and Wildlife Service, unpublished data). From 1992-1998, a more intensive eider survey has been conducted that samples about 4% of the Arctic coastal plain each year. Fewer Steller's eiders were seen during the eider survey than during the waterfowl breeding pair survey; no more than 14 were seen in any year and none were seen east of the Colville River (W. Larned, Fish and Wildlife Service, unpublished data). These observations indicate that although Steller's eiders occur as far east as Prudhoe Bay, they rarely breed in the Prudhoe Bay area and the species occurs primarily in NPR-A to the west of the Colville River.

Analysis for Status of the Species/Critical Habitat

Based on the information available, the Service has determined that the likelihood that Steller's eiders occur in the Liberty project area is very low and that no take is anticipated. Additionally, no designated critical habitat lies within the action area of the proposed project. Therefore, we have determined that the Liberty project is not likely to adversely affect either Steller's eider or its designated critical habitat.

Spectacled Eider

Status of the Species

The spectacled eider was listed as threatened on May 10, 1993 (58 FR 27474). The Service designated critical habitat for the species in breeding habitat on the Yukon-Kuskokwim Delta, and in marine areas in Norton Sound, Ledyard Bay, and the Bering Sea between St. Lawrence and St. Matthew islands February 6, 2001 (66 FR 9146).

The final recovery plan for the species (Fish and Wildlife Service 1996) designated three separate breeding populations of spectacled eiders: Arctic Russia, North Slope of Alaska, and YK Delta. New information acquired since the plan was released demonstrates that the three breeding populations are discrete. In most cases, the Service lists taxa under the Act over the entire extent of their range. Most consultations reflect this scale in their evaluations of proposed actions. In cases where subspecies or distinct population segments are listed under the Act, the scale of a biological opinion may be restricted to the range of the specific subspecies or distinct population segment(s). Where a final recovery plan exists that identifies specific recovery units it is appropriate to evaluate the impacts of a proposed project on a recovery unit basis. The recovery plan for the spectacled eider identifies three breeding populations as individually classifiable recovery units (pages 33-38) and it provides biological support for using the approach taken in this consultation.

The best information available for this species compels the Service to confine the scale of consultation to the potentially affected breeding population and to evaluate the impacts of the Liberty project to the North Slope breeding population of the spectacled eider.

Species Description

The spectacled eider is a large-bodied sea duck, and is one of three species in the genus *Somateria* along with common (*S. mollissima*) and king eiders (*S. spectabilis*). The spectacled eider has a green crown and nape with a long, sloping forehead, large and distinctive white eye patches, a charcoal-colored chest, and a white back (Palmer 1976). Body plumage of the male spectacled eider most closely resembles that of the larger common eider. Females of all three *Somateria* species have similar body plumage, with only slight differences in head coloration and

shape. Juvenile and adult female spectacled eiders are barred and mottled brown with indistinct eye patches. The iris of both sexes is blue, and the bills of adult males and females are orange and bluish-grey, respectively.

Life History

Basic life history information is lacking for many sea duck species, including spectacled eiders. The available information indicates that sea ducks are long-lived, annual adult survival is high (in a healthy population), annual recruitment to breeding age is low, annual breeding rates and success are variable, and clutch size is small (Goudie *et al.* 1994).

Spectacled eiders are dispersed, low-density nesters on the North Slope (Derksen *et al.* 1981; Warnock and Troy 1992), however, in Arctic Russia most spectacled eiders nest semi-colonially in association with gull or tern colonies (Kistchinski and Flint 1974; Kondratev and Zadorina 1992). On the Yukon-Kuskokwim Delta, spectacled eiders are primarily dispersed nesters, although Johnsgard (1964) found spectacled eider nests clumped at some sites.

Pairs and small flocks of spectacled eiders arrive on breeding grounds on the North Slope in late May to early June. The number of pairs seen on the North Slope increases until mid-June (Smith *et al.* 1994). Nest initiation begins shortly thereafter, and the number seen declines rapidly as males depart and females begin incubation in late June (Anderson and Cooper 1994; Anderson *et al.* 1995).

Incubation lasts 20-25 days (Dau 1974; Kondratev and Zadorina 1992; Harwood and Moran 1993; Moran and Harwood 1994; Moran 1995) and hatching occurs on the North Slope from mid- to late July (Warnock and Troy 1992). Observations from the Yukon-Kuskokwim Delta indicate that hatch date may depend on the timing of spring weather conditions (C. Dau, Fish and Wildlife Service, pers. comm.; C. Harwood, Fish and Wildlife Service, pers. comm.). Spectacled eiders typically lay three to six eggs, although average clutch size may vary among years and locations.

Predators of spectacled eider eggs include gulls, jaegers, and foxes. In the Kuparuk oilfield on the North Slope, spectacled eider nest success in 1993-1995 ranged between 28.6 and 35.7% (Anderson *et al.* 1996). In Arctic Russia, apparent nest success varied from < 2% in 1994 to 27% in 1995; foxes, gulls, and jaegers are suspected to have depredated most of the nests (D. Esler, U.S. Geological Survey, pers. comm.). On Kigigak Island in the Yukon-Kuskokwim Delta, nest success ranged from 20% to 95% in 1991-1995 (Harwood and Moran 1991, 1993; Moran and Harwood 1994; Moran 1995, 1996). Nest success was higher in 1992 than in other years of observation, possibly because foxes were eliminated from the island prior to the nesting season that year. Nest success at Hock Slough, also on the Yukon-Kuskokwim Delta, ranged between 30% and 80% in 1991-1995 (J.B. Grand, U.S. Geological Survey, pers. comm.).

Studies tracking hens with broods through the brood-rearing period on the Yukon Kuskokwim Delta (J.B. Grand, pers. comm.) and on the North Slope (TERA 1995) show that broods rarely move more than 1.5 km (0.9 mi) during a 24-hour period. In the 50-day brood-rearing period before young fledge, most broods stay within 5 km (3.1 mi) of the nest sites (J.B. Grand, pers. comm.), although some may move up to 14 km (8.7 mi) before fledging (Dau 1974; Harwood and Moran 1993; Moran and Harwood 1994; TERA 1995). After fledging, females with broods move from freshwater to marine habitats (Dau 1974; Kistchinski and Flint 1974).

On the nesting grounds, spectacled eiders feed by dabbling in shallow freshwater or brackish ponds, or on flooded tundra (Dau 1974; Kistchinski and Flint 1974). Food items include molluscs; insect larvae such as craneflies, trichopterans, and chironomids; small, freshwater crustaceans; and plants or seeds (Cottam 1939; Dau 1974; Kistchinski and Flint 1974; Kondratyev and Zadorina 1992). Little information exists on the diet of spectacled eiders at sea. Cottam (1939) found amphipods and molluscs in two birds collected at Saint Lawrence Island in January. Foods in spectacled eiders shot by subsistence hunters in May and June near Saint Lawrence Island consisted of molluscs and crabs (M.R. Petersen, U.S. Geological Survey, pers. comm.).

Habitat and Distribution

Important habitats for Arctic-breeding spectacled eiders include large river deltas, tundra, and wet, polygonized coastal plains with numerous waterbodies. Pre-nesting spectacled eiders use aquatic sedge (*Carex* spp.) with deep polygons, brackish water, salt marsh, salt-killed tundra, and shallow open water with islands or polygonized margins in the Colville River Delta region (Johnson *et al.* 1997). West of the Colville River, in the National Petroleum Reserve-Alaska (NPR-A), Derksen *et al.* (1981) found spectacled eiders in shallow aquatic grass (*Arctophila fulva*) ponds and deep open lakes in June. East of the Colville River in the Kuparuk Oilfield, pre-nesting eiders were found in *Arctophila* ponds, basin wetland complexes, and aquatic sedge (*Carex*) habitats (Anderson *et al.* 1996).

Spectacled eiders used many of the same habitats preferred during pre-nesting for nesting. Twenty-eight percent of nests found on the Colville River Delta between 1992 and 1994 were located in aquatic sedge with deep polygons (Johnson *et al.* 1997). Brackish water, nonpatterned wet meadow, and salt-killed tundra were also important nesting habitats. Spectacled eider nests were strongly associated with waterbodies in all habitats in which they occurred, averaging 1 meter from permanent water. This association has also been reported on the Yukon-Kuskokwim Delta where nests were an average of 2.1 meters from water (Dau 1974). In the Kuparuk Oilfield, spectacled eiders also nested close to waterbodies, with average distances ranging from 2 to 9.6 meters (6.6 to 31.5 ft) during 4 years of study. Waterbodies in closest proximity to nests were primarily basin wetland complexes, shallow and deep open lakes, and water with emergents (Anderson *et al.* 1997). In the National Petroleum Reserve-Alaska (NPR-A), spectacled eiders used shallow *Carex* ponds during the summer (Derksen *et al.* 1981).

On the Colville River Delta, broods were found in salt-killed tundra and brackish water, suggesting a strong attraction to coastal habitats (Johnson *et al.* 1997). In the NPR-A, spectacled eider broods used mostly shallow *Carex* ponds, deep open lakes, and deep *Arctophila* ponds (Derksen *et al.* 1981).

Telemetry studies of spectacled eiders near Prudhoe Bay (TERA 1999) indicate that spectacled eiders make limited use of the Beaufort Sea prior to molt migration. Only 2 of 50 instrumented males were recorded using marine waters prior to departure from the Prudhoe Bay area. None of the 83 females tracked in the Prudhoe Bay area were recorded using marine waters. These results may underestimate actual use of nearshore waters because the investigators were limited in their ability to access coastal sites. Nevertheless, the best available evidence indicates that spectacled eiders in the Prudhoe Bay area make little use of the Beaufort Sea during the nesting season. Whether this is typical of birds nesting elsewhere on the North Slope is unknown.

Recent satellite telemetry studies provide data regarding postbreeding dispersal and migration routes of spectacled eiders between breeding, molting, and wintering areas. Males breeding in the Prudhoe Bay region depart the area and re-enter the marine environment during the latter half of June; females with broods in the Prudhoe Bay area leave in late August to early September (Petersen *et al.* 1999). TERA (1999) found females (including failed and non-breeders) leaving the Prudhoe Bay area from late June until observations ceased in late August, and satellite-tracking showed some to occupy the Beaufort Sea as late as mid-September (Petersen *et al.* 1999). Of 13 females tracked, 10 were detected in the Beaufort Sea at least once before they arrived in the Chukchi Sea. Of those 10, 5 were located only once in the Beaufort, and 5 were detected twice. The data indicate a residence period in the Beaufort Sea of 1-8 days, with a mean of about 4 days.

The distance males traveled offshore ranged between 2.7 and 13.8 km (median=6.6 km) for 24 birds, and the distance females traveled offshore ranged between 8.4 and 24.8 km (median=16.5 km) for 24 birds (Petersen *et al.* 1999). The difference between distances males and females migrate offshore is likely attributable to the fact that the polar ice pack is further offshore when the majority of females enter the Beaufort, making open water available further offshore. There is no evidence that females migrate westward overland, bypassing the Beaufort Sea (TERA 1999, Petersen *et al.* 1999), however, TERA (1999) proposes the possibility that males may take overland routes after breeding. If females do not migrate overland, this would suggest they are more vulnerable to oil spills because few, if any, would avoid possible exposure to marine spills. Many of the telemetry locations of females were in the Harrison Bay area, although generally farther from shore than males. None were in the lagoon system between Prudhoe Bay and Oliktok Point (TERA 1999).

Molting areas for post-breeding spectacled eiders have been observed in Russia in Mechigmenskiy Bay, on the eastern coast of the Chukotsk Peninsula and off the coast of the Indigirka and Kolyma River deltas (Petersen *et al.* 1999); Alaska's Ledyard Bay, southwest of Point Lay (Petersen *et al.* 1999); Peard Bay (Laing and Platte 1994); and Norton Sound (Larned

and McCaffery 1993; Petersen *et al.* 1999). During molt they use marine waters that are between 5 meters (16.4 feet) and 25 meters (82.0 feet) deep. The primary wintering location is approximately 80 km (50 mi) south of Saint Lawrence Island in openings in the pack ice (Larned *et al.* 1995). Most, if not all spectacled eiders winter together in this area utilizing benthic resources in waters up to 75 meters (246.1 feet) deep.

Leads in ocean ice are important spring migratory pathways for marine birds (Richardson and Johnson 1981) and mammals migrating along the Beaufort Sea coast in Alaska and Canada. Large flocks of king and common eiders migrate as early as late April through early June past Point Barrow following leads 5 to 6 km (3 to 4 mi) offshore (Woodby and Divoky 1982, Suydam *et al.* 1997). All species of eiders use this lead system, flying at altitudes that are usually less than 10 m (33 ft) (Johnson and Richardson 1982). However, very little information is available regarding the migration routes of spectacled eiders in spring. Because little, if any open water is present during the time that they migrate, they may migrate along more direct, inland routes. Use of an overland route was suggested by Myres (1958), who observed spectacled eiders migrating along the Meade and Inaru rivers, and reported local observations that migrating birds flew inland north of Wainwright. Woodby and Divoky (1982) recorded only one spectacled eider among approximately 420,000 king and common eiders in offshore leads north of Barrow in 1976. Suydam *et al.* (1997) recorded 55 spectacled eiders among 213,477 king and common eiders from 1 May-10 June, 1994, representing 0.03% of the total. In contrast, Lehnhausen and Quinlan (1981) estimated that 7% of approximately 14,300 eiders migrating past Icy Cape (200 km southwest of Barrow, on the Chukchi Sea coast) between 27 May-12 June 1980 were spectacled eiders. The difference in relative abundance indicates that spectacled eiders may take an inland route from the Chukchi Sea to nesting areas on the Arctic coastal plain. There are few other published observations to support or refute this hypothesis. Low numbers were seen at migration count sites in Simpson Lagoon (Richardson and Johnson 1981); possibly these birds were making local movements while awaiting thaw on the tundra (TERA 1999).

Although little open water is likely to be available to spring migrants between the mainland shore and the proposed Liberty island site, river water overflows the sea ice between mid-May and mid-June. Spring migrant eiders along the Beaufort coast are attracted to these areas of open water (Bergman *et al.* 1977, Schamel 1978, Moitoret 1983). Richardson and Johnson (1981) speculated that this effect would be more pronounced in heavy-ice years when there is little open water available offshore, and a similar effect may occur in years when snow-melt is delayed on the tundra.

Knowledge of the distribution of breeding spectacled eiders on the North Slope is provided by aerial surveys that locate pairs of spectacled eiders prior to nest initiation (Table 1). If one assumes that spectacled eiders take the most direct route from their breeding grounds to the marine environment, one would expect those birds nesting west of Barrow, as well as some of those nesting to the east may avoid using the Beaufort Sea during molt migration. Under the same assumption (that birds do not go further east upon completion of breeding activities), one

would expect only 1.4% of the population segment breeding east of Foggy Island Bay to migrate past the proposed project infrastructure. It is important to recognize, however, that this assumption has not been verified by field studies.

Population Size

Aerial surveys of eiders conducted on the North Slope annually since 1993 provide an index of population size. The “population estimate” of spectacled eiders produced by these surveys has ranged from 5,345 to 9,497 with an average of 7,029 indicated birds over the interval 1993-2000 (Larned *et al.* 2001). However, it is important to consider that this is an index based on the number of birds detected, and is not adjusted to reflect that an unknown number of spectacled eiders are undoubtedly present in the sample area but not detected by the survey. Therefore, although the index accurately indicates population trends and distribution, it cannot be used to determine population size without correcting for birds not detected. Only preliminary evaluation of the visibility of spectacled eiders has been conducted, and none have been conducted on the North Slope, thus the counts indicate the minimum population size. Information needed to estimate actual population size is lacking.

The worldwide population has been estimated from late winter aerial surveys in the Bering Sea. After the initial discovery of a substantial proportion of the known population of spectacled eiders in the Bering Sea ice south of Saint Lawrence Island in 1995, subsequent surveys were conducted in March 1996 and 1997. Complete photographic coverage was obtained for 18 of 19 flocks observed in 1997 (Larned and Tiplady 1997). This photo-census resulted in an estimate of 363,030 spectacled eiders (95% CI=333,526-392,532), plus one flock only visually estimated at 900. Depending on sea ice conditions, spectacled eider flocks have been found dispersed in large openings in fragmented sea ice or confined to a few small openings when ice is more extensive. Because the number of spectacled eiders found wintering together substantially exceeds earlier estimates of total population size, it is believed that most or all of the world’s population winters in this area.

Status and Distribution

Reasons for Listing

The primary reason for listing spectacled eiders was their rapid decline on the Yukon-Kuskokwim Delta where numbers apparently decreased 94-98% between the early 1970s and the early 1990s.

The reasons for the dramatic decline on the Yukon-Kuskokwim Delta are unknown; however, studies on the Delta have found that exposure to lead shot is likely adversely affecting the nesting population of spectacled eiders in that region (Flint *et al.* 1997). The cause of death of four spectacled eiders in 1992-1994 was diagnosed as lead poisoning from ingested lead shot

(Franson *et al.* 1995). Subsequent studies showed blood lead levels in adult females increasing during the breeding season from 13% in pre-nesting to 36% during brood rearing (Flint *et al.* 1997). However, the relative importance of lead poisoning and other factors influencing the species' status is unknown.

Little information is available on the deposition of lead and its effects on waterfowl on the North Slope. However, lead shot was found in the gizzards of 11% ($n = 126$) of long-tailed ducks (*Clangula hyemalis*) sampled in the Teshekpuk Lake area in 1979-1980 (Taylor 1986). It was not determined if the lead shot was ingested on the North Slope or elsewhere.

Predators of spectacled eider adults, eggs, and young include Arctic foxes (*Alopex lagopus*), red foxes (*Vulpes fulva*), large gulls (*Larus* spp.), jaegers (*Stercorarius* spp.), snowy owls (*Nyctea scandiaca*), and common ravens (*Corvus corax*). Native elders on the North Slope believe that fox numbers have increased in recent decades as a result of reduced trapping (R. Suydam, North Slope Borough, pers. comm.). Population sizes of large gulls on the North Slope may also have increased recently as a result of increased food supplies from anthropogenic wastes. Wastes made available from the commercial fishing industry in the Bering Sea and North Pacific, along with an increase in the garbage generated by coastal communities, may have also increased the year-round food supply for gulls (R. Suydam, pers. comm.). However, no studies have been conducted to document trends in predator numbers or distribution on the North Slope.

Little data are available on the effects of disturbance on nesting eiders. However, studies of disturbance on other waterfowl in the oilfields suggest that construction activities near nests can decrease nest attentiveness (Murphy and Anderson 1993). Anderson *et al.* (1992) found that increased noise associated with the expansion of the Central Compressor Plant at Prudhoe Bay changed the distribution of nonbreeding spectacled eiders during the summer; however, no nesting eiders were monitored during that study. Also in the Prudhoe Bay area, Warnock and Troy (1992) found that the distribution of spectacled eiders and their nests did not appear to be related to the distribution of oilfield facilities.

Some spectacled eider habitat on the North Slope has been eliminated as a result of filling wetlands in the villages and oilfields for roads and pads. Disruption or destruction of rare and/or high quality wetlands has been minimized when possible through cooperative efforts of the Corps of Engineers and permittees such as the North Slope Borough, oil companies, ADOT/PF, and others under Section 404 of the Clean Water Act. It is unknown if spectacled eider numbers or reproductive performance are limited by access to nesting habitat.

Subsistence harvest of spectacled eider eggs and adults is another potential factor in the decline of the spectacled eider population. Alaska Natives have traditionally harvested eiders and their eggs in coastal villages during spring and fall. Although human populations on the Yukon-Kuskokwim Delta and in North Slope communities have grown substantially, it is unknown how

hunting pressure has changed over time. The past or current effects of subsistence harvest on spectacled eider populations are unknown.

Other potential factors that may affect spectacled eider survival have been suggested. These include changes in biotic community structure in marine areas in which spectacled eiders winter and therefore, a reduction in populations of preferred prey resources in the area south of Saint Lawrence Island, exposure to environmental contaminants, disease, parasites, and accidental strikes and/or disturbance of benthic feeding areas by commercial fishing operators.

Rangewide Trend

There are no long-term studies of population trends of spectacled eiders on the North Slope. However, annual aerial surveys conducted across the North Slope since 1993 provide population indices useful for assessing short-term trends. Population indices show only a statistically insignificant trend over the interval 1993-2000 (Larned *et al.* 2001). However, it is important to note that failure to detect a statistically significant trend does not conclusively demonstrate that population size is stable. A variety of factors may affect the number of eiders detected during aerial surveys, including annual variation in breeding propensity, effort, breeding phenology, behavior, and how long males remain in the survey area after breeding. Given the short interval over which the surveys have been conducted, the influence of these factors on the number of birds detected may have masked variation caused by change in population size if a trend exists. There has also been no detectable trend in population size from 1991 to 1997 in the local population nesting near Prudhoe Bay (D. Troy, pers. comm.). As with the aerial surveys, however, the relatively short interval over which the observations have been made may have limited the likelihood that a trend was detectable, if one existed.

Analysis for Status of the Species/Critical Habitat

The Service has determined that the spectacled eider is likely to be adversely affected by the Liberty Development Project. These adverse effects could or will result from disturbance from construction and operation activities, collisions with structures on Liberty island, possible changes in predator populations in the region, and mortality and/or decreased reproductive potential as a result of oil spills. Designated spectacled eider critical habitat will not be affected by the Liberty project.

Environmental Baseline

The environmental baseline is the current status of listed or proposed species or their habitat as a result of past and ongoing human and natural factors in the area of the proposed action.

Status of the Species Within the Action Area

Based on the information available, the extent to which the project area is currently used by spectacled eiders is low compared to other areas on the North Slope. Aerial surveys conducted in 6 subareas within the Prudhoe Bay area indicate a low density of pairs within the action area (Kadleroshilik subarea average density over 3 years was 0.090 pairs per kilometer² and Sagavanirktok subarea average density over 5 years was 0.092) (TERA 1997). To the west of these two subareas, for example in the Prudhoe, Sakonowiyak, and Milne subareas, average densities gradually increase: 0.113, 0.116, 0.170, respectively. Alternatively, the Shavirovik subarea to the east of the Liberty project area had an average density of 0.006 after 2 years of surveys. These distributional trends are similar to the trends indicated by surveys over the entire Arctic Coastal Plain (for example, Larned *et al.* 2001) in which spectacled eider density drops east of Prudhoe Bay. As noted in previous sections, there is currently no detectable trend in spectacled eider population size on the North Slope. Furthermore, the factors that limit population size on the North Slope have not been identified. Therefore, it is impossible to determine whether human activity and habitat alteration have affected the status of the species in the project area. However, activities that may have affected the status of the species in the project area include disturbance from oilfield operations, aircraft overflights, research efforts, increases in predator populations as a result of anthropogenic wastes and availability of nest or den sites, and loss of breeding habitat.

Factors Affecting the Species Environment Within the Action Area

Onshore activities in the action area include operations and surveillance of the Badami pipeline from the air, and research activities (such as aerial surveys). Current activities occurring offshore in the project area may include: boat operations such as supply vessels (barges), subsistence activities, and resource exploration activities (such as seismic surveys).

The Service conducted a formal section 7 consultation with the U.S. Army Corps of Engineers, the Environmental Protection Agency, and the MMS for the Northstar Development, located approximately 30 to 35 miles west of the proposed Liberty Development. The Northstar project will increase the risk of oil spills in the waters of the surrounding area as oil will be transported through a subsea pipeline in the next one to two years. The biological opinion estimated the project could potentially adversely affect spectacled eiders through collisions with structures on the island, and oil spills. The amount of take anticipated was up to 2 spectacled eiders from collisions and an unknown number from marine oil spills (but not at a level that would result in jeopardy). The estimated likelihood of one or more marine spills $\geq 1,000$ barrels from the Northstar project was ~13% (7% for blowouts and tank spills and 5-6% for the marine segment of the pipeline). However, since the Service provided mandatory terms and conditions in the biological opinion and other conditions of the permit (requiring additional monitoring of the offshore pipeline for chronic leaks), the likelihood of impacts of a spill on spectacled eiders will be reduced. Spectacled eider losses in the event of a marine oil spill will also likely be reduced by terms and conditions regarding spill response (alternative hazing methods), which require

using state-of-the-art hazing technology and incorporating species-specific information in the oil spill contingency plan.

Effects of the Action on Spectacled Eiders

Regulations (51 FR 19958) that implement Section 7(a)(2) of the Act define “jeopardize the continued existence of” as “to engage in an action that reasonably would be expected, directly or indirectly, to reduce appreciably the likelihood of both the survival and recovery of a listed species in the wild by reducing the reproduction, numbers, or distribution of that species.” The Service’s analysis of effects, therefore, includes the likelihood that a given threat will occur and the potential impact that the threat could have on spectacled eiders. Direct and indirect effects of the proposed action on spectacled eiders include oil spills, collisions with structures on Liberty island, helicopter overflights, barge and other marine vessel transport, enhanced predator populations, and habitat loss.

Oil Spills

Several sources of fuel and crude oil spills are possible throughout the life of the Liberty project. These include a drilling blowout, failure of diesel fuel storage tanks, rupture of the pipeline (loss > 0.15% of flow rates), chronic leaks from the pipeline (loss < 0.15% of flow rate), or spills from barges or trucks used to transport fuel oil to the Liberty island (Liberty DEIS). Historical data from North Slope oil production show that between 0 and 102 crude or diesel oil spills per year occurred from 1970-1997; most were small spills (typically <2 barrels), and mean crude oil spill size in all years was < 100 barrels (Northstar EIS). Because the more likely small- and medium-sized spills (<1,000 barrels) on land are usually more easily detected and contained, and the terrestrial density of spectacled eiders is relatively low in the project area, few individual spectacled eiders are likely to be exposed to oil on land. In the marine environment, spectacled eider densities are also very low; spectacled eider density in an offshore aerial survey (including the Liberty project area) was 0.04 birds per km² (Stehn and Platte 2000). Therefore, because smaller spills impact a smaller area, and the density of spectacled eiders in the project area is so small, there is a very low likelihood that spectacled eiders would be affected by small- and medium-sized spills in the marine environment. Thus, the remainder of this discussion focuses exclusively on large (\geq 1,000 barrels) spills in the marine environment. To conclude whether large marine oil spills might jeopardize the survival and/or recovery of spectacled eiders, the Service must consider the likelihood of one or more large spills occurring, and the likelihood that the spill(s) will kill enough spectacled eiders to appreciably reduce the survival and recovery of the North Slope population. The Service used the quantitative probability estimates of offshore spill occurrence provided in the Liberty DEIS. We recognize that other approaches exist, and that MMS has provided a lower estimate of spill occurrence based on an evaluation of the pipeline technology being employed at Liberty. However, we believe the more conservative approach is to base the biological opinion on existing offshore data, versus a qualitative assessment of technology, due largely to the unknown/unproven nature of oil and gas production in the Arctic Ocean. We do not know how accurate the quantitative estimates are (confidence

intervals do not exist), but believe they are the best information available on which to base a jeopardy finding. Estimation of incidental take is based on the most reasonably likely scenario, including probability of occurrence and potential for effect.

Exposure to oil can affect birds in several ways. Most birds exposed to oil die within a short period of time (Hunt 1987), often due to hypothermia resulting from loss of the insulative properties of their plumage (Piatt *et al.* 1990). Embryos (King and Lefever 1979) or young (Peakall *et al.* 1982) can be killed after contact with hens' oiled plumage. Birds that ingest contaminated food can suffer fatal toxicological effects (Peakall *et al.* 1983). Species that feed on invertebrates or other organisms that bioaccumulate contaminants derived from petroleum are particularly vulnerable to disease and other stress for an extended time after a spill.

Evaluating the likelihood of spills from the proposed Liberty project is constrained by the lack of comparable projects in the Arctic. While the Northstar project is similar in design, it is not operating and has provided no information on operations of offshore facilities or subsea pipelines in the Beaufort Sea that could be applied to the Liberty project. Therefore, MMS derived estimates of spill probabilities from various sources of data such as spill rates from Outer Continental Shelf (OCS) facilities and pipelines, Alaska North Slope onshore facilities and pipelines, European onshore and offshore pipelines, and onshore and offshore U.S. Petroleum product pipelines. After evaluating these data sources, the Service concludes that the OCS data collected by MMS is the most relevant to the Liberty project. Therefore, the analyses performed by MMS and S.L. Ross Environmental Research Ltd. (both use the OCS data) to define a spill occurrence estimate will be assumed. These analyses focus on offshore infrastructure and use a spill size equal to or greater than 1,000 barrels. Using the OCS data, MMS estimates spill occurrence for the production island to be approximately 4% (including blowouts [0.1%], accidents on the island, and storage tank accidents), and spill occurrence for the offshore pipeline to be approximately 5%. The offshore pipeline spill probability is based on data from the Gulf of Mexico and therefore, the estimates were corrected for anchor drag and trawler events to be more applicable to conditions in the Beaufort Sea. The draft EIS only presents an S.L. Ross spill occurrence estimate for the Liberty pipeline (not the island facility). S.L. Ross estimates a spill occurrence of 1.6 to 2.3% for the offshore portion of the Liberty pipeline. Combining these two estimates, the chance of an offshore spill equal to or greater than 1,000 barrels from the Liberty project is in the range of 5.6 to 9%. As mentioned previously, this does not include a qualitative evaluation of current technology or the unique hazards (e.g., ice gouge and strudel scour) of operating in the Beaufort Sea. In terms of spill risks, it is unknown whether the potential improvements in technology will offset the potential hazards, or whether a given hazard or technology will prove more significant. We will therefore use the existing OCS data and the referenced spill occurrence estimates as a basis for our analysis.

The estimated likelihood of a spill from the marine segment of the pipeline is based upon spill rates from onshore pipelines and offshore pipelines in the Gulf of Mexico and Pacific coast. Although the best quantified estimate of a large offshore spill associated with Liberty may be in the range of 5.6-9%, we recognize that environmental hazards and project-specific factors (e.g.,

thicker pipeline wall) will likely influence the actual spill probability to an unquantifiable degree. Additionally, cleanup of a spill in the Beaufort is anticipated to be constrained by ice and weather conditions in the area. In many cases, final cleanup may only be possible after the region of the oil spill is free of ice (National Research Council 1994). Because of unstable and broken ice conditions in the area, once a leak is detected, response for containment and cleanup of a spill will be delayed or hindered during at least 6 months of the year, and when cleanup activities are not hindered by ice, cleanup would be possible only as weather permits. In addition, historical recovery rates of spilled oil are traditionally very low even when cleanup is not hampered by Arctic weather and frozen or partially frozen seas. Based on national and international data, recovery rates are usually not above 10% (Alaska Department of Environmental Conservation 1998, National Research Council 1994). Recent spill drills in broken ice conditions in the Beaufort Sea indicated that only limited recovery of oil from the ocean surface is likely during spring (0 to 10% broken ice conditions) and that no recovery of oil from the surface is likely with >10% broken ice conditions (see Joint Agency Evaluation of the Spring and Fall 2000 North Slope Broken Ice Exercises, Robertson and DeCola December 2000).

Our knowledge regarding likely spill trajectories and impacts to birds has improved since the consultation for the Northstar project because of newly gathered data on bird use of the area (Service-Migratory Bird Management unpub. data) and because of recent analysis of exposure of birds to assumed oil spills from the Liberty project (Stehn and Platte 2000). The recent bird studies in the Beaufort Sea provide distribution information on sea ducks (including spectacled eiders), loons, and gulls during July and August in 1999 and 2000. Stehn and Platte (2000) combined these data along with simulated oil spill trajectories provided from MMS in a geographic information system (GIS) to construct a spatial model overlaying bird density estimates with predicted trajectories of oil spills, provides quantitative estimates of the numbers of birds likely to be exposed to oil from spills originating at the Liberty project. The spill trajectory data are based on wind speed and water current data collected over a number of years in the Beaufort Sea. Two spill scenarios of chronic leaks were modeled: a 1,580 barrel spill resulting from 30-day leak and a 5,912 barrel spill resulting from a 60-day leak. No spectacled eiders were exposed to oil in 451 out of 500 simulated spills (90%) for the 1,580 barrel spill, and in 442 out of 500 simulated spills (88%) for the 5,912 barrel spill. In five of 500 simulated spills, 39 to 41 eiders were exposed for the 1,580 barrel spill, and 48 to 52 eiders were exposed for the 5,912 barrel spill. The predicted average number of spectacled eiders exposed was 1.1 (maximum 41) for the 1,580 barrel spill in July, and 1.7 (maximum 52) for the 5,912 barrel spill in July. Given that the estimated population size of spectacled eiders within the survey area during July was 540, the model predicts that, of those, the average (and maximum) proportions likely to be affected are 0.20% (7.6%) and 0.37% (9.6%) for the 1,580 and 5,912 barrel spills, respectively.

Model limitations and assumptions may underestimate spill-related mortality, because:

- (1) Only spill trajectory data for open water conditions were utilized;

- (2) Bird distribution data for July and August were based on aerial surveys and do not account for the movement of birds into a spill area;
- (3) During aerial surveys, 333 eiders were seen that were not identified to species level. However, given the relative scarcity of spectacled eider sightings during the surveys, few of these are likely to be spectacled eiders (7 out of 333 based on relative proportions of birds identified to species). Therefore, we assume that failure to identify all eiders to species level would have minimal effect on the model output;
- (4) The extent of some of the modeled spill trajectories went beyond the bird survey area, meaning the mortality estimate may not account for some birds that could have encountered oil in these areas; and,
- (5) Some modeled spill trajectories terminated once the spill encountered land (including barrier islands). Therefore, potential resuspension of oil and continued exposure is not accounted for in the model.

Conversely, there are several model assumptions that may overestimate mortality, because:

- (1) It is assumed that 100% of birds exposed to oil die;
- (2) No cleanup of oil is assumed; and
- (3) No hazing or movement of birds out of a spill area is assumed.

The risk that many eiders would come in contact with a spill is also reduced if the following preliminary conclusions prove correct: 1) some spectacled eiders fly overland directly to the Chukchi Sea; 2) most of the spectacled eiders using the Beaufort Sea do not linger more than a few days; and 3) schedule of departure is protracted for successful females, thus exposing only a small portion of the population at any given time.

While the Service recognizes the limitations of the model, including the larger potential for underestimation compared to overestimation of mortality, the Service believes it provides useful estimates of spill-related mortality should a spill occur. Note that the probability of spill occurrence is not included in this model.

The assumed maximum mortality of spectacled eiders resulting from a large oil spill is 52 birds (Stehn and Platte 2000), but the likelihood of a marine spill affecting a large proportion of the North Slope population of spectacled eiders is reduced by several factors. The probability of a moderate- to large-sized spill is low (~5.6-9% for a spill >1,000 barrels). Eiders are present for only about 4 months of the year; so spills occurring in the remainder of the year have no likelihood of contact with eiders at the time of the spill (although oil that is not recovered in the

cleanup process and associated indirect effects on benthic habitats and food supply may affect eiders returning to the breeding grounds). The Service assumes that eiders that have completed their breeding season re-enter the marine environment and migrate west only. Only a small proportion of the spectacled eider population breeds east of Prudhoe Bay (~1.4%). It is assumed that spectacled eider use of the Beaufort Sea in the vicinity of the proposed Liberty island is limited to those birds that nest south or east of Liberty. Use of the lagoon system south of the barrier islands also appears to be minimal, although significant post-breeding use of the Beaufort Sea may occur in Harrison Bay (Petersen *et al.* 1999, TERA 1999). The likelihood of a spill reaching this area is low and is reflected in Stehn and Platte's (2000) low mortality estimates in spite of high use of this area.

Collisions with Structures on Liberty Island

Migrating birds are at risk of collision with man-made structures. An estimated 30,000 birds were killed at a 1000-ft TV tower in Eau Claire, Wisconsin on two nights in September, 1963 (Kemper 1964). Collision mortality is particularly well documented for nocturnal migrating passerines (World Wildlife Fund 1996). Weather conditions are believed to affect risk, as summarized by Brown (1993) and Avian Power Line Interaction Committee (1994). Lighting is also an important variable affecting collision risk, because nocturnal migrant passerines appear to become disoriented when they approach brightly lit structures, and often circle the structures until they collide (Weir 1976, Avery *et al.* 1980, Brown 1993). The effects of lighting can be intensified in certain weather conditions (such as haze, fog, or drizzle) that refract light and increase the illuminated area (Weir 1976).

Non-passerine birds are also susceptible to collision mortality. Some nocturnal procellariiform birds (e.g., shearwaters and storm petrels) are attracted to lights, become disoriented, and crash into structures (Swales 1965, Telfer *et al.* 1987). An estimated 6000 crested auklets (*Aethia cristatella*) crash-landed onto a fishing vessel near Kodiak Island in January 1977, in stormy weather (Dick and Donaldson 1977). In that case, turning off the outside lights on the vessel reduced the rate of collision. Large numbers of migrating eared grebes were forced down in a snowstorm in central and southern Utah (Jehl 1993). It was reported that "the birds did not fall uniformly, but apparently were attracted to lights from towns and intersections." A similar incident was reported by Cottam (1929).

Anecdotal accounts establish that waterfowl are also susceptible to the risks of collision. Many ducks (mostly redheads and mallards) were killed by colliding with buildings, trees, and utility lines during an October storm (rain, snow and foggy conditions) in South Dakota (Schorger 1952). In a review of non-hunting waterfowl mortality, Stout and Cornwell (1976) suggested that risk of collision with transmission lines may be exacerbated by fog. Although there are many accounts of waterfowl striking utility lines (Avian Power Line Interaction Committee 1994), the incidence of wire collisions is probably not representative of the risk of collision with solid structures, because utility wires may be more difficult for birds to detect.

Collision risks for eiders and other seabirds are poorly documented. One long-tailed duck and one common eider (*Somateria mollissima*) were killed when they collided with the personnel quarters and a drill rig at Northstar in late September 2000. A small number of eiders (5-6) were reported killed at radio towers near the Bay of Fundy in fall migration (Peter Hicklin, pers. comm.). An unknown (but apparently small) number of eiders were reported to have collided with the Waterflood buildings at the end of West Dock, Prudhoe Bay (Lori Quakenbush, pers. comm.). “Hundreds” of king and common eiders were forced to shore in Nome, Alaska, on a stormy night with strong winds, fog, and light snow and were killed (J. Burns, pers. comm.). Many of the eiders killed in Nome apparently hit utility lines based on the presence of electrocution burns on their wings. Only 19 bird casualties were noted in a 15-month study of collisions at a windfarm in Blyth Harbor, England, but eiders were disproportionately represented among the collision victims, relative to their abundance in the area. This result was attributed to flight characteristics and behavior; poor-visibility conditions were also thought to be a factor (Still *et al.* 1994). In a radar study of flight behavior of birds around offshore wind turbines in northern Europe, Dirksen *et al.* (1997) found that diving ducks (primarily tufted ducks [*Aythya fuligula*] and scaup [*Aythya marila*], with lesser numbers of pochards [*Aythya ferina*], goldeneyes [*Bucephala clangula*], and mergansers [*Mergus spp.*]), appeared to avoid the structures when visibility was poor. On moonless nights, fewer ducks passed between the turbines, and a greater number of flight paths were parallel to the row of turbines. Of those ducks that approached the turbines, a “larger number turned away at short distances on moonless nights.” The authors cautioned that these evasive behaviors were exhibited by birds that were wintering locally and possibly habituated to the structures, and that the reactions of migrants might differ. At Liberty island, which will present a novel obstruction, birds may not habituate, and therefore, migrating birds may be vulnerable to collisions.

There are a number of anecdotal accounts of eider collisions with structures and vessels in Alaska. Dick and Donaldson (1978) reported small numbers of king eiders (*Somateria spectabilis*) colliding with a fishing vessel at night off southern Kodiak Island, in March and early April, 1973. A single flock of a hundred or more eiders crashed into a ship southwest of the Bering Strait in November or December of 1984 (J. Sease, pers. comm.). Other cases of collisions with ships have been reported from the Bering Sea (S. Tuttle, pers. comm.). The incidents involved fishing vessels located near the edge of the pack ice, and were usually associated with snow and “icing” conditions, stormy weather, and/or darkness. Eiders were reported to have circled the brightly lit vessels until they crashed into the ships and died. This is the only report we have located that directly implicates bright lights as a factor in collision deaths of eiders. Specimens were not saved in most cases of shipboard collision, so species identity cannot be confirmed, but one sample of specimens obtained by the Service included Steller’s eiders, harlequin ducks (*Histrionicus histrionicus*), and Barrow’s goldeneyes (*Bucephala islandica*).

Eiders (king, common, and small numbers of spectacled eiders) migrate east past the project area in spring from the latter half of May through the first half of June (Richardson and Johnson 1981). Westward molt migration of seabirds (king eiders, common eiders, long-tailed ducks,

surf and white-winged scoters [*Melanitta perspicillata* and *M. deglandi*]) is protracted, lasting from mid-June (for males) through September (for successfully-breeding females) (Johnson and Richardson 1982; TERA 1999).

Darkness and fog during eider migrations would increase risk of collision. Eider migration during the months of May-July occurs during the period of virtually continuous daylight (sunset first occurs on 29 July). During August and September, day length declines rapidly, with over 12 hours of darkness by the end of September. Thus, visibility may be impaired by darkness only during the latter portion of the fall migration period; in August and September, successfully breeding females and juveniles should predominate (TERA 1999). A recent radar study in Barrow to monitor eider migration in the vicinity of a tower array during August and September found that movement rates of eiders (mostly king and common eiders) were greater during night-time hours than daytime hours (Day *et al.* 2001). Movement rates were highest during nights without precipitation and lowest during nights with precipitation, and highest during nights with good visibility and lowest during nights with poor visibility.

National Weather Service data from Barrow and Barter Island (Table 2) show that many days with heavy fog can be expected during both spring and fall migration periods. Fog in the region increases in spring to a maximum in July and August, and tapers off in September. Barter Island experiences more foggy conditions than Barrow, with heavy fog occurring on half the days in July and August. Therefore, a combination of increasing darkness and heavy fog can be expected in August and possibly September.

Table 2. Average number of days of heavy fog in Barrow and Barter Island, May-September.

Site	Sample Size (years)	Days with heavy fog: visibility 400 m (1/4 mile)				
		<u>May</u>	<u>June</u>	<u>July</u>	<u>August</u>	<u>September</u>
Barrow ^a	58	7.1	10.0	11.9	11.4	4.9
Barter Island ^b	34	7.6	11.3	15.1	15.5	10.9

^aNational Weather Service, 1998

^bNational Weather Service, 1997

The Barrow radar study documented that eiders do not vary their flight behavior by time of day, light condition, or visibility (Day *et al.* 2001). However, eiders flew a significantly greater distance from the tower array during the day than at night and during daytime without precipitation than during all other light conditions. Only 5 of 186 flocks (2.7%) passed within

500 meters of the tower array. Although none of the 5 flocks passing within 500 m of the tower array exhibited a discernible response as they passed the tower, the small sample size was not enough to make conclusions regarding behavior of flocks around tower arrays. Because eiders apparently rely on visual cues during migration, and because many migrate during darkness, the risk of collision could be significant during migration, especially for novel hazards such as Liberty island. Also, eiders tend to fly low, increasing the risk of collision. Johnson and Richardson (1982) reported that 88% of eiders flew below an estimated altitude of 10 m (32 ft) and well over half flew below 5 m (16 ft). The perimeter berm around Liberty island is planned to be 7 m (23 ft) above sea level, and therefore poses a risk to migrating eiders in the area. The pipe rack and buildings will rise above 10 m, and the top of the flare boom is expected to be 64 m (210 ft) in height. Migrating eiders fly at a mean speed of approximately 86 km/hr (54 mph) (Day *et al.* 2001). Eiders flying at average speed during periods of heavy fog (visibility less than 400 m) would have a maximum of 18 seconds to detect and interpret a visual stimulus, and to take evasive action to avoid collision, the ability of large eider flocks to do so is unknown.

Spectacled eiders are not common in the vicinity of the proposed project location. The Service is less concerned about collisions by locally-breeding birds and more concerned about the potential impact of offshore structures on migrating spectacled eiders. However, very little is known of their migration pathways in the area. Radar data to be collected in Fall, 2001 at Northstar may provide this information. The Service assumes that based on existing data (migration studies and satellite telemetry studies [TERA 1999, Petersen *et al.* 1999]), spectacled eiders tend to migrate offshore from the barrier islands and that the proposed project is not within the migration pathway of a significant number of spectacled eiders.

Helicopter Overflights

The Draft EIS estimates that 10 to 20 helicopter round trip flights per day would transport crew and construction materials between Deadhorse and Liberty island during breakup and summer of the second year of construction. The maximum number of flights during this period (April through September), would be 3,660. However, bad weather will inevitably ground a certain number of flights, requiring crew boats to be used instead. In addition to the construction-phase flights, it is estimated that 1 helicopter flight per day during the broken ice period and 1 or 2 flights per week will be required to access the pipeline and tie-in area for final pipeline tests. Once production is under way, 2 to 3 helicopter trips per week during summer and winter and a daily trip during breakup will be required to transport personnel to and from the island; all offshore and onshore pipelines will be visually checked for problems weekly and visits to the tie-in pad will be accessed by helicopter at least once per week.

Heavy helicopter traffic over nesting and brood-rearing areas could adversely affect spectacled eiders by: 1) displacing adults and/or broods from preferred habitats during pre-nesting, nesting, and brood rearing; 2) displacing females from nests, exposing eggs or ducklings to inclement weather or predators; and 3) reducing foraging efficiency and feeding time. The behavioral response of spectacled eiders to aircraft overflights is unknown, but observers in helicopters

flying over pre-breeding or nesting spectacled eiders noted that most of the birds did not take wing (Chris Dau, U.S. Fish and Wildlife Service, pers. comm.). Some spectacled eiders nest and rear broods near the Deadhorse Airport, indicating that some individuals may tolerate frequent aircraft noise. Individual tolerances are likely to vary, however, and the intensity of disturbance associated with the proposed action could, in some cases, be greater than that experienced by birds near the airport. Some birds may be displaced, with unknown physiological and reproductive consequences. The heaviest helicopter use will occur in the construction year, as the number of overflights in subsequent years will be substantially reduced, greatly diminishing possible disturbance. The number of eiders that would be exposed to helicopter overflights is limited, however, because the potential routes are short; (a direct route from Deadhorse to Liberty island is approximately 24 km (15 mi) over land). Also, during the breeding season, eiders are dispersed at low density, averaging one pair per 11 km² (3 mi²) both in the Sagavanirktok subarea in 1992-1996 and the Kadleroshilik subarea in 1993-1995 (TERA 1997). Thus, it is expected that 4 or 5 pairs may be present within 1 km (0.6 mi) of an average flight line of 24 km.

Because of low recorded densities of breeding and migrating spectacled eiders in the project area, and because the effects of helicopters are not expected to be severe enough to result in adverse impacts to spectacled eiders, therefore, the Service believes that the use of helicopters to transport personnel and supplies will not result in take of spectacled eiders.

Barge and Other Marine Vessel Transport

Seagoing barges will transport large modules and other supplies and equipment from Southcentral Alaska. They will be in the Point Barrow area from mid-August through mid- to late September and will then dock at Liberty island to offload modules. Vessels from Prudhoe Bay or Endicott would travel shoreward of the barrier islands. An estimated 150 local round trips by marine vessels plus 2 sealifts could occur during the construction phase. Barges from Prudhoe Bay will be used to transport materials during construction and drilling equipment and consumables during drilling. Once construction and drilling is complete, approximately 5 barge trips per summer will be required to resupply the island.

Although most of the marine traffic will occur when spectacled eiders may be present in the marine environment in the project area, the Service does not expect appreciable effects on spectacled eiders to result from disturbance by barges or other marine vessels. This determination is based on the fact that (1) the number of spectacled eiders in the area is low, and (2) given the slow rate at which barges travel, the Service believes that any spectacled eiders in the path of oncoming barges will be able to relocate at negligible physiological cost.

Enhanced Predator Populations

Several North Slope predators that prey on waterfowl eggs and young concentrate in areas where anthropogenic food sources are made available. Examples include glaucous gulls, ravens, and Arctic foxes that are abundant near camps, roads, oilfields, and villages. For ravens and foxes, there is evidence showing population increases and/or changes in distribution in response to anthropogenic food sources, and the breeding distribution of ravens has expanded on the North Slope because buildings and other structures in oil developments provide nesting sites (Day 1998). The potential predation pressure that foxes and, to a lesser degree, gulls and ravens exert on ground-nesting birds is well-documented, and predation may be the single most important factor affecting nest success in some areas.

Spectacled eiders may be adversely affected by increased numbers or distribution of predators as a result of the presence of the oilfields. Ravens apparently never successfully nested in Barrow until 1991 when a single pair began raising a brood each year on a man-made structure (R. Suydam, pers. comm.). In 1991, one of these ravens was seen depredating five eggs from two Steller's eider nests (Quakenbush *et al.* 1995). Although information showing a direct link between oilfield activities and waterfowl nest predation rates is lacking, the Service assumes that actions that artificially enhance predator populations are a potential adverse impact to listed eiders.

Because of low recorded densities of breeding spectacled eiders in the project area, and because of the lack of information regarding the association between oilfield development and operations and populations of nest predators, the Service believes that the potential enhancement of predator populations will not result in take of spectacled eiders. In addition, State of Alaska, Department of Environmental Conservation regulations that govern refuse management in oilfields prohibit feeding wildlife, leaving human food or garbage in a manner that attracts wildlife [5 AAC 92.230], and allowing bears access to landfills [18 AAC 60.010(a)]. The Service assumes that the applicant will completely comply with all applicable regulations governing waste management, and therefore anticipates that no take of listed eiders will result from an increase in predator abundance caused by improper waste management.

Habitat Loss

Benthic and onshore habitat will be lost due to the proposed project. Placement of gravel on the seafloor to create Liberty island will eliminate approximately 22.4 acres of marine benthic habitat, plus approximately 73.4 acres for the subsea pipeline trench. It is unclear whether the loss of marine benthic habitat in the project area would affect spectacled eiders. There were no spectacled eiders recorded during July and August in 1999 and 2000 at the island and pipeline location, although they may forage or rest there during migration. Onshore, some habitat will be lost to gravel mining (Kadleroshilik Mine alternative would eliminate 31 acres, very little of which appears to be spectacled eider habitat) and disposal for excess dredged materials (62

acres), as well as a pipeline landfall gravel pad (0.3 acres), and pipeline tie-in pad (0.62 acres). Spectacled eider nests have not been recorded in the proposed gravel pad locations. The gravel pads would be constructed during the winter, thus eliminating direct impacts to spectacled eider individuals or nests as a result of filling wetlands. Only one nest site has been recorded adjacent to the proposed Kadleroshilik mine site during 3 years of surveys (1993-1995) (TERA1997). Because the mine would be in use during the arrival of pre-breeding spectacled eiders, it is likely that the birds would be precluded from nesting within a certain distance of the mine.

Because of low recorded densities of breeding and migrating spectacled eiders in the project area and the assumed availability of alternative areas for nesting and feeding, the Service believes that loss of marine benthic and onshore breeding habitats will not result in take of spectacled eiders.

Cumulative Effects

Cumulative effects include the effects of future State, local or private actions that are reasonably certain to occur in the action area considered in this biological opinion. Future Federal actions that are unrelated to the proposed action are not considered in this section because they require separate consultation pursuant to section 7 of the Act.

State of Alaska oil development activities will be subject to Federal permitting requirements because these actions would occur in wetlands and nearshore areas requiring authorizations under the Clean Water Act and Rivers and Harbors Act, respectively. Therefore, because Federal approval requires section 7 consultation, the Service does not incorporate these State actions into the cumulative effects. Other State or private actions reasonably certain to occur within or near the proposed project would include future subsistence harvest activities, commercial fishing, research activities, and recreational activities. There is no indication that the extent or magnitude of any of these activities will increase beyond their current level, nor that take of listed eiders will increase as a result of these activities.

Conclusion for Spectacled Eiders

After reviewing the current status of spectacled eiders, the environmental baseline for the action area (including the potential impacts from the Northstar project), the effects of the proposed project and the cumulative effects, it is the Service's biological opinion that the proposed Liberty project is not likely to jeopardize the continued existence of spectacled eiders. No critical habitat has been designated near the project area; therefore, none will be affected.

Regulations (51 FR 19958) that implement Section 7(a)(2) of the Act define "jeopardize the continued existence of" as "to engage in an action that reasonably would be expected, directly or indirectly, to reduce appreciably the likelihood of both the survival and recovery of a listed species in the wild by reducing the reproduction, numbers, or distribution of that species." In evaluating the impacts of the proposed Liberty project to spectacled eiders, the Service identified

a series of direct impacts that could result, such as disturbance from helicopter overflights, collisions with Northstar facilities by migrants, and changes in the number or distribution of predators. However, the Service believes that the combined impacts to spectacled eiders through these avenues will be minimal for the reasons given in the *Effects of the Action* section of this biological opinion.

The Service believes that the greatest risk to listed species from the proposed Liberty project is potential impacts from accidental oil spills in the marine environment. However, as noted above, for the project to jeopardize the continued existence of spectacled eiders, an appreciable reduction in the likelihood of both the survival and recovery of one or both species must be “reasonably expected to occur.” Thus, when determining whether possible oil spills jeopardize listed species, the Service must consider the following: 1) the likelihood of one or more spills occurring; and 2) if one or more spills occur(s), the likelihood that the spill(s) will kill enough spectacled eiders to appreciably reduce their likelihood of survival and recovery. The likelihood of ≥ 1 spill $\geq 1,000$ bbl in size occurring during the lifetime of Liberty is estimated to be 5.6-9%, including the production facility and pipeline. The Northstar project, which is expected to result in production beginning in autumn 2001, was estimated to have a 12-13% probability ≥ 1 spill $\geq 1,000$ bbl in size occurring during the lifetime of the project. Thus, in combination, the Northstar and proposed Liberty projects have an estimated probability of 17.6-22% probability of ≥ 1 spill $\geq 1,000$ bbl in size occurring during the lifetime of the two projects (note that this estimate of spill probability includes the likelihood of ≥ 1 spill at either Northstar or Liberty or both). However, the impacts of a spill to biological resources (e.g. eiders) vary with spill volume, spill trajectory, whether the resource is present during the time of year that spilled oil is present, and the length of time that oil persists in the environment. This is exemplified by Stehn and Platte’s (2000) model which estimated mortality from spills caused by Liberty at 0-52 spectacled eiders, with an average mortality resulting from 500 spill events at 1.1-1.7 spectacled eiders (see *Effects of the Action* section for discussion of the model and its limitations). Although the estimates of spill probability and impacts to spectacled eiders are constrained by lack of information on oil development, subsea pipeline safety, and spectacled eiders in the region, the available information leads the Service to conclude that an appreciable reduction in the likelihood of survival and recovery of listed eiders is not reasonably expected to occur.

INCIDENTAL TAKE STATEMENT

Section 9 of the Act and Federal regulations pursuant to section 4(d) of the Act prohibit the take of endangered and threatened species, respectively, without special exemption. Take is defined as to harass, harm, pursue, hunt, shoot, wound, kill, trap, capture or collect, or to attempt to engage in any such conduct. Harm is further defined by the Service to include significant habitat modification or degradation that results in death or injury to listed species by significantly impairing essential behavioral patterns, including breeding, feeding, or sheltering. Harass is defined by FWS as intentional or negligent actions that create the likelihood of injury to listed species to such an extent as to significantly disrupt normal behavior patterns which include, but are not limited to, breeding, feeding or sheltering. Incidental take is defined as take that is

incidental to, and not the purpose of, the carrying out of an otherwise lawful activity. Under the terms of section 7(b)(4) and section 7(o)(2), taking that is incidental to and not intended as part of the agency action is not considered to be prohibited taking under the Act provided that such taking is in compliance with the terms and conditions of this Incidental Take Statement.

The measures described below are non-discretionary, and must be undertaken by the MMS, so that they become binding conditions of any grant or permit issued to BPXA, as appropriate, for the exemption in section 7(o)(2) to apply. The MMS has a continuing duty to regulate the activity covered by this incidental take statement. If the MMS fails to assume and implement the terms and conditions, or fails to require BPXA to adhere to the terms and conditions of the incidental take statement through enforceable terms that are added to the permit or grant document, the protective coverage of section 7(o)(2) may lapse. In order to monitor the impact of incidental take, the MMS must report the progress of the action and its impact on the species to the Service as specified in the incidental take statement [50 CFR § 402.14(i)(3)].

Amount or Extent of Take Anticipated

Oil Spills

The Service estimates the amount of take for the Liberty project based on the average value from an oil spill model analyzing likely spill trajectories with eider distribution data (Stehn and Platte 2000). The result from an assumed July spill of 5,912 barrels was an average 1.7 spectacled eiders that are predicted to encounter oil. Therefore, the Service assumes the take will be lethal take of 2 birds (rounded up from 1.7) taken during the life of the project as a result of ingestion of oil and/or oiled prey, or by oiled plumage. The assumptions of the model and other considerations are discussed in the *Effects of the Action* section.

Collisions with Structures on Liberty Island

The Service anticipates that some take of spectacled eiders may result from collisions with structures on Liberty island. Despite their limited occurrence in the project area, spectacled eiders remain susceptible to collisions and the Service believes that some take of spectacled eiders is possible through collisions. The Service anticipates that up to 5 spectacled eiders will be taken (killed) in a 5-year period as a result of colliding with the perimeter berm, pipe rack, flare boom, or other structures and buildings on the island. However, the Service does not anticipate that spectacled eiders would be killed each year. It is likely that none will be killed in most years, but that occasionally, because of fog and weather conditions during peak migration, a few may be killed in one year. Take is expected to be in the form of lethal take resulting from the impact of colliding with stationary structures on the island.

Effect of the Take

The proportion of spectacled eiders that are anticipated to be taken during the life of Liberty project is 17 birds (2 from oil spills, and 5 every 5 years of the project, or approximately 15 spectacled eiders) out of an estimated 7,029 on the North Slope (Larned *et al.* 2001). In the accompanying biological opinion, the Service determined that this level of anticipated take is not likely to result in jeopardy to spectacled eiders.

Reasonable and Prudent Measures for Spectacled Eiders

In the following sections the Service provides reasonable and prudent measures and terms and conditions that would minimize the effects of incidental take of spectacled eiders. Anticipated incidental take of spectacled eiders would occur via the following identified threats: 1) oil spills and related clean-up activities, and 2) migrants striking the perimeter berm, pipe rack, flare boom, or other structures and buildings on the island. The reasonable and prudent measures and terms and conditions included in this biological opinion are designed to minimize take of spectacled eiders from these threats.

The Service believes that the following reasonable and prudent measures are necessary and appropriate to minimize impacts of incidental take of spectacled eiders:

- (1) To minimize mortality of spectacled eiders from oil spills and spill clean-up activities, state-of-the-art bird deterrent devices and technology will be maintained and available for immediate deployment in the event of a spill in the Beaufort Sea.
- (2) To minimize the likelihood that migrating spectacled eiders will strike structures on Liberty island, lighting will be designed to minimize the amount of fixed light radiating outward from Liberty island. Additionally, a study of the response of migrating eiders to lighting and structures in their path will be conducted. The results of this study will be used to develop the lighting scheme for Liberty island. During the migration season, when not in use, crane booms will be stored in a fashion that reduces the possibility that they will pose an obstacle to migrating birds to the maximum extent practicable.

Terms and Conditions for Spectacled Eiders

In order to be exempt from the prohibitions of section 9 of the Act, MMS must comply with the following terms and conditions, which implement the reasonable and prudent measures described above and outline required reporting/monitoring requirements. These terms and conditions are non-discretionary.

To minimize the exposure of spectacled eiders to oil in the event of a spill:

- (1) Results of the most recent surveys and/or radio-tracking studies that identify areas in the Beaufort Sea that are important to spectacled eiders will be appended to the Liberty C-Plan and other applicable strategy documents that direct oil spill response. Since radio-tracking studies are typically a multi-year effort, the plan should be updated either upon completion of the study, or every 2 years in which data are collected. In particular, the information will be used to modify spill response so that important eider use areas and habitat types will be protected to the maximum extent possible.
- (2) To deter spectacled eiders from encountering spilled oil, *Breco* buoys (Navenco Marine Company) or similar devices (to be approved by the Service) purchased as a term and condition of the Northstar project, will be kept at Prudhoe Bay ready for immediate deployment. Training personnel in the use and maintenance of the *Breco* buoys will be done in compliance with the manufacturer's recommendations. Reporting requirements in the C-Plan will be modified to include relevant information on training and maintenance actions necessary for the *Breco* buoys.

To minimize the likelihood that migrating spectacled eiders will strike the sea wall or other structures on Liberty Island:

- (3) Lights should be shaded in a manner that directs light downward and toward the interior of the island, and reduces light radiating outward from the island.
- (4) A study, mutually-approved by the Service, MMS, and BPXA, of the response of migrating eiders to structures and lighting shall be conducted. The study at Northstar Island may fulfill this obligation as long as the Service, MMS, and BPXA agree that it adequately addresses the effects of sea ice conditions, weather, annual variation, and other identifiable factors that may confound the response of eiders. In particular, it is imperative that the inferences drawn are believed to apply to the environmental conditions expected at Liberty.
- (5) Results of the study of the response of migrating eiders to structures and lighting shall be used to generate "best managements practices" for lighting that strive to minimize collisions. The resulting best management practices shall then be implemented in the lighting scheme at Liberty.
- (6) To the maximum extent practicable, crane booms will be stored at an angle greater than 45 degrees above the horizontal and along an east-west axis. This shall only

apply when cranes are not in use (and are not expected to be used within the next 48 hours), and during the migration period when eiders may be present (15 May to 30 September).

The Service believes that no more than 17 spectacled eiders will be incidentally taken as a result of the proposed action (oil spills and collisions). The reasonable and prudent measures, with their implementing terms and conditions, are designed to minimize the impact of incidental take that might otherwise result from the proposed action. If, during the course of the action, this level of incidental take is exceeded, such incidental take represents new information requiring reinitiation of consultation and review of the reasonable and prudent measures provided. The Federal agency must immediately provide an explanation of the causes of the taking and review with the Service the need for possible modification of the reasonable and prudent measures.

Coordination of Incidental Take Statements with Other Laws, Regulations, and Policies

The Fish and Wildlife Service will not refer the incidental take of any migratory bird or bald eagle for prosecution under the Migratory Bird Treaty Act of 1918, as amended (16 U.S.C. §§ 703-712), or the Bald and Golden Eagle Protection Act of 1940, as amended (16 U.S.C. §§ 668-668d), if such take is in compliance with the terms and conditions (including amount and/or number) specified herein. This statement applies only to species listed under the Endangered Species Act which, in this case, includes only the spectacled eider.

Reinitiation Notice

This concludes formal consultation on the action(s) outlined in the request. As provided in 50 CFR § 402.6, reinitiation of formal consultation is required where discretionary Federal agency involvement or control over the action has been retained (or is authorized by law) and if: 1) the amount or extent of incidental take is exceeded; 2) new information reveals effects of the agency action that may affect listed species or critical habitat in a manner or to an extent not considered in this opinion; 3) the agency action is subsequently modified in a manner that causes an effect to the listed species or critical habitat not considered in this opinion; or 4) a new species is listed or critical habitat designated that may be affected by the action. In instances where the amount or extent of incidental take is exceeded, any operations causing such take must cease pending reinitiation.

The Service will consider that reinitiation is required under subsection (2) above if any spectacled eiders (or other listed species) are taken as a result of any oil spill from either the proposed project or from the Northstar project. Occurrence of an offshore oil spill will warrant reinitiation because current risk assessment and spill response strategies are based on inadequate information on spill risk, trajectory, and response efficacy in the Beaufort Sea. Should a spill that affects the species occur, valuable new information will become available that will assist in risk assessment and developing management strategies to avoid or minimize impacts. Therefore, reinitiation of consultation is appropriate. Furthermore, all operations causing such take must cease pending reinitiation.

LITERATURE CITED

- Alaska Department of Environmental Conservation, Division of Spill Prevention and Response. 1998. Response to comments and decision document for BP Exploration's Northstar Development project. Unpublished report.
- American Ornithologists' Union. 1983. Check-list of North American birds. 6th edition. American Ornithologists' Union, Washington, DC. 877 pp.
- Anderson, B.A., and B.A. Cooper. 1994. Distribution and abundance of spectacled eiders in the Kuparuk and Milne Point oilfields, Alaska, 1993. Final report prepared for ARCO Alaska, Inc., and the Kuparuk River Unit, Anchorage, Alaska by Alaska Biological Research, Inc., Fairbanks, Alaska; and BBN Systems and Technologies Corp., Canoga Park, California.
- Anderson, B.A., S.M. Murphy, M.T. Jorgenson, D.S. Barber, and B.A. Kugler. 1992. GHX-1 waterbird and noise monitoring program. Final report prepared for ARCO Alaska, Inc., Anchorage, Alaska by Alaska Biological Research, Inc., Fairbanks, Alaska; and BBN Systems and Technologies Corp., Canoga Park, California.
- Anderson, B.A., A.A. Stickney, R.J. Ritchie, and B.A. Cooper. 1995. Avian studies in the Kuparuk Oilfield, Alaska, 1994. Unpublished report for ARCO Alaska, Inc. and the Kuparuk River Unit, Anchorage, Alaska.
- Anderson, B.A., A.A. Stickney, and R.J. Ritchie. 1996. Avian studies in the Kuparuk Oilfield, Alaska, 1995. Unpublished report prepared for ARCO Alaska, Inc. and the Kuparuk River Unit, Anchorage, Alaska by Alaska Biological Research, Inc.
- Avery, M.L., P.F. Springer, and N.S. Dailey. 1980. Avian mortality at man-made structures: an annotated bibliography (Revised). U.S. Fish. Wildl. Serv., Biological Services Program, National Power Plant Team, FWS/OBS-80/54. 152 pp.
- Avian Power Line Interaction Committee (APLIC) . 1994. Mitigating bird collisions with power lines: the state of the art in 1994. Edison Electric Institute. Washington, D.C. 78 pp.
- Bellrose, F.C. 1980. Ducks, geese and swans of North America. 2nd edition. Stackpole Books, Harrisburg, Pennsylvania.
- Bergman, R.D., R.L. Howard, K.F. Abraham, and M.W. Weller. 1977. Water birds and their wetland resources in relation to oil development at Storkerson Point, Alaska. Resource

- Publication 129. Washington, DC: USDOl, Fish and Wildlife Service, 38 pp.
- Brooks, W.S. 1915. Notes on birds from east Siberia and Arctic Alaska. *Bulletin of the Museum of Comparative Zoology* 59:359-413.
- Brown, W.M. 1993. Avian collisions with utility structures, biological perspectives. Pages 12-1 - 12-13 *in*: EPRI, Proceedings: Avian interactions with utility structures, international workshop. EPRI TR-103268. v.p.
- Cottam, C. 1929. A shower of grebes. *Condor* 31:80-81.
- Cottam, C. 1939. Food habits of North American diving ducks. U.S. Department of Agriculture Technical Bulletin No. 643. Washington, D.C.
- Cramp, S., K.E.L. Simmons, I.J. Ferguson-Lees, R. Gillmor, P.A.D. Hollom, R. Hudson, E.M. Nicholson, M.A. Ogilvie, P.J. Olney, K.H. Voous, and J. Wattel, eds. 1977. Handbook of the birds of Europe, the middle East, and North Africa. Vol I. Oxford University Press, Oxford, United Kingdom.
- Dau, C.P. 1974. Nesting biology of the spectacled eider, *Somateria fischeri* (Brandt), on the Yukon-Kuskokwim Delta, Alaska. M.S. Thesis, Univ. Alaska, Fairbanks, Alaska.
- Day, R.H. 1998. Predator populations and predation intensity on tundra-nesting birds in relation to human development. Unpublished report prepared for Northern Alaska Ecological Services, U.S. Fish and Wildlife Service, Fairbanks, Alaska.
- Day, R.H., J.R. Rose, B.A. Cooper, and R.J. Blaha. 2001. Migration rates and flight behavior of migrating eiders near towers at Barrow, Alaska. Unpublished report prepared for Northern Alaska Ecological Services, U.S. Fish and Wildlife Service, Fairbanks, Alaska and Department of Wildlife Management, North Slope Borough, Barrow, Alaska.
- Derksen, D.V., T.C. Rothe, and W.D. Eldridge. 1981. Use of wetland habitats by birds in the National Petroleum Reserve-Alaska. U.S. Fish and Wildlife Service Resource Publication 141, Washington, D.C.
- Dick, M.H. and W. Donaldson. 1978. Fishing vessel endangered by crested auklet landings. *Condor* 80:235-236.
- Dirksen, S., S. Spaans, and J. van der Winden. 1997. Nocturnal collision risks of birds with wind turbines in tidal and semi-offshore areas. *In* G. Solari and C. Ratto (eds.): Proceedings of the International Workshop on Wind Energy and Landscape (WEL),

Genua. Balkema, Rotterdam.

- Fay, F.H. 1961. The distribution of waterfowl on St. Lawrence Island, Alaska. Annual Report of the Wildfowl Trust 12:70-80.
- Flint, P.L. and M. P. Herzog. 1999. Breeding of Steller's eiders on the Yukon-Kuskokwim Delta, Alaska.
- Flint, P.L., M.R. Petersen, and J.B. Grand. 1997. Exposure of spectacled eiders and other diving ducks to lead in western Alaska. Canadian Journal of Zoology 75:439-443.
- Franson, J.C., M.R. Petersen, C.U. Meteyer, and M.R. Smith. 1995. Lead poisoning of spectacled eiders (*Somateria fischeri*) and of a common eider (*Somateria mollissima*) in Alaska. Journal of Wildlife Diseases 31:268-371.
- Goudie, R.I., A.V. Kondratyev, S. Brault, M.R. Petersen, B. Conant, and K. Vermeer. 1994. The status of sea ducks in the North Pacific Rim: Toward their conservation and management. Transactions of the North American Wildlife and Natural Resources Conference 59:27-49.
- Harwood, C.M., and T. Moran. 1991. Nesting chronology, reproductive success, and brood rearing for spectacled and common eiders on Kigigak Island, 1991. Unpublished report prepared for U.S. Fish and Wildlife Service, Bethel, Alaska.
- Harwood, C.M., and T. Moran. 1993. Productivity, brood survival, and mortality factors for spectacled eiders on Kigigak Island, Yukon Delta NWR, Alaska, 1992. Unpublished report prepared for U.S. Fish and Wildlife Service, Bethel, Alaska.
- Hunt, G., Jr. 1987. Offshore oil development and seabirds: The present status of knowledge and long-term research needs. Pages 539-586 in D.F. Boesch and N.N. Rabailais, eds. Long-term environmental effects of offshore oil and gas development. Elsevier Applied Science: New York, New York.
- Jehl, J. R., Jr. 1993. Observations on the fall migration of eared grebes, based on evidence from a mass downing in Utah. Condor 95:470-473.
- Johnsgard, P.A. 1964. Observations on the biology of the spectacled eider. Wildfowl 15:104-107.
- Johnson, C.B., B.E. Lawhead, J.R. Rose, A.A. Stickney, and A.M. Wildman. 1997. Wildlife studies on the Colville River Delta, Alaska, 1996. Unpublished report prepared for

- ARCO Alaska, Inc. and Kuukpik Unit Owners, Anchorage by ABR, Inc., Fairbanks, Alaska.
- Johnson, S.R., and W.J. Richardson. 1982. Waterbird migration near the Yukon and Alaska coast of the Beaufort Sea: II. Moulting migration of seabirds in summer. *Arctic* 35(2): 291-301.
- Jones, R.D. 1965. Returns from Steller's eiders banded in Izembek Bay, Alaska. *Wildfowl Trust Annual Report* 16: 83-85.
- Kemper, C.A. 1964. A tower for TV, 30,000 dead birds. *Audubon* 66:86-90.
- Kertell, K. 1991. Disappearance of the Steller's eider from the Yukon-Kuskokwim Delta, Alaska. *Arctic* 44(3):177-187.
- King, K., and C. Lefever. 1979. Effects of oil transferred from incubating gulls to their eggs. *Marine Pollution Bulletin* 10:319-321.
- Kistchinski, A.A. 1973. Waterfowl in north-east Asia. *Wildfowl* 24:88-102.
- Kistchinski, A.A., and V.E. Flint. 1974. On the biology of the spectacled eider. *Wildfowl* 25:5-15.
- Kondratev, A.V., and L.V. Zadorina. 1992. Comparative ecology of the king eider *Somateria spectabilis* and spectacled eider *Somateria fischeri* on the Chaun tundra. *Zool. Zhur.* 71:99-108. (in Russian; translation by J. Pearce, National Biological Survey, Anchorage, Alaska).
- Laing, K., and B. Platte. 1994. Ledyard and Peard Bays spectacled eider surveys, August 18-19, 1994. Unpublished trip report prepared for Migratory Bird Management, U.S. Fish and Wildlife Service, Anchorage, Alaska.
- Larned, W.W., G.R. Balogh, and M.R. Petersen. 1995. Late winter distribution of spectacled eiders (*Somateria fischeri*) in the Bering Sea, 1995. Unpublished report. U.S. Fish and Wildlife Service, Migratory Bird Management, Anchorage, AK. 21 pp.
- Larned, W.W., W.I. Butler, and G.R. Balogh. 1994. Steller's eider spring migration surveys, 1992-1993. Unpublished progress report prepared for Migratory Bird Management, U.S. Fish and Wildlife Service, Anchorage, Alaska.
- Larned, W.W., and B. McCaffery. 1993. Norton Sound eider survey, August 30-31, 1993.

- Unpublished trip report prepared for Migratory Bird Management, U.S. Fish and Wildlife Service, Anchorage, Alaska.
- Larned, W.W., R. Platte, and R. Stehn. 2001. Eider breeding population survey, Arctic Coastal Plain, Alaska, 1999-2000. Unpublished report prepared for Migratory Bird Management, U.S. Fish and Wildlife Service, Anchorage, Alaska..
- Larned, W.W., and T. Tiplady. 1997. Late winter population and distribution of spectacled eiders (*Somateria fischeri*) in the Bering Sea, 1996-1997. Unpublished report prepared for Migratory Bird Management, U.S. Fish and Wildlife Service, Anchorage, Alaska.
- Lehnhausen, W.A. and S.E. Quinlan. 1981. Bird migration and habitat use at Icy Cape, Alaska. Unpublished report prepared for U.S. Fish and Wildlife Service, Anchorage, Alaska.
- Moitoret, C.S. 1983. Bird use of Arctic coastal shorelines at Canning River delta, Alaska.M.S. Thesis, Univ. Of Alaska, Fairbanks.
- Moran, T. 1995. Nesting ecology of spectacled eiders on Kigigak Island, Yukon Delta NWR, Alaska, 1994. Unpublished report prepared for U.S. Fish and Wildlife Service, Bethel, Alaska.
- Moran, T. 1996. Nesting ecology of spectacled eiders on Kigigak Island, Yukon Delta NWR, Alaska, 1995. Unpublished report prepared for U.S. Fish and Wildlife Service, Bethel, Alaska.
- Moran, T., and C.M. Harwood. 1994. Nesting ecology, brood survival, and movements of spectacled eiders on Kigigak Island, Yukon Delta NWR, Alaska, 1993. Unpublished report prepared for U.S. Fish and Wildlife Service, Bethel, Alaska.
- Murphy, S.M., and B.A. Anderson. 1993. Lisburne terrestrial monitoring program: The effects of the Lisburne Development Project on geese and swans 1985-1989. Unpublished final report prepared for ARCO Alaska, Inc. by Alaska Biological Research, Inc., Fairbanks, Alaska.
- Myres, M.T. 1958. Preliminary studies of the behavior, migration and distributional ecology of eider ducks in northern Alaska, 1958. Unpublished Interim Progress Report to the Arctic Institute of North America. Fairbanks, AK.
- National Research Council. 1994. Environmental information for outer continental shelf oil and gas decisions in Alaska. National Academy of Sciences, Washington, D.C.

- National Weather Service. 1997. Local Climatological Data, Barter Island, Alaska. NOAA. National Climatic Data Center. Asheville, North Carolina.
- National Weather Service. 1998. Local Climatological Data, Barrow, Alaska. NOAA. National Climatic Data Center. Asheville, North Carolina.
- Palmer, R.S. 1976. Handbook of North American Birds. Vol. 3. Yale University Press, New Haven, Connecticut.
- Peakall, D., D. Hallett, J. Bend, G. Foureman, and D. Miller. 1982. Toxicity of Prudhoe Bay crude oil and its aromatic fractions to nestling Herring Gulls. *Environmental Resources* 27:206-211.
- Peakall, D., D. Miller, and W. Kinter. 1983. Toxicity of crude oils and their fractions to nestling Herring Gulls 1. Physiological and biochemical effects. *Marine Environmental Resources* 8:63-71.
- Petersen, M.R. 1980. Observations of wing-feather moult and summer feeding ecology of Steller's eiders at Nelson Lagoon, Alaska. *Wildfowl* 31:99-106.
- Petersen, M.R. 1981. Populations, feeding ecology and molt of Steller's eiders. *Condor* 83:256-262.
- Petersen, M.R., W.W. Larned, and D.C. Douglas. 1999. At sea distribution and abundance of spectacled eiders (*Somateria fischeri*): 120 year-old mystery solved.
- Piatt, J. C. Lensink, W. Butler, M. Kendziorek, and D. Nysewander. 1990. Immediate impact of the "Exxon Valdez" oil spill on marine birds. *Auk* 107:387-397.
- Quakenbush, L., R. Suydam, K. Fluetsch, and C. Donaldson. 1995. Breeding biology of Steller's eiders nesting near Barrow, Alaska, 1991-1994. Unpublished report, Northern Alaska Ecological Services, U.S. Fish and Wildlife Service, Fairbanks, Alaska.
- Quakenbush, L., R.S. Suydam, K.M. Fluetsch, and T. Obritschkewitsch. 1998. Breeding habitat use by Steller's eiders near Barrow, Alaska, 1991-1996. Unpublished draft report prepared for Northern Alaska Ecological Services, U.S. Fish and Wildlife Service, Fairbanks, Alaska.
- Richardson, W.J., and S.R. Johnson. 1981. Waterbird migration near the Yukon and Alaskan coast of the Beaufort Sea: I. Timing, routes and numbers in spring. *Arctic* 34(2): 108-121.

- S.L. Ross Environmental Research Ltd, D.F. Dickins and Assoc. Ltd., and Vaudrey and Assoc. Ltd. 1998. Evaluation of cleanup capabilities for large blowout spills in the Alaskan Beaufort Sea during periods of broken ice. Anchorage, AK: Alaska Clean Seas and USDOJ, MMS, Alaska OCS Region.
- Schamel, D. 1978. Bird use of a Beaufort sea barrier island in summer. *Canadian Field-Naturalist* 92:55-60.
- Schorger, A.W. 1952. Ducks killed during a storm at Hot Springs, South Dakota. *Wilson Bulletin* 64:113-114.
- Smith, L.N., L.C. Byrne, C.B. Johnson, and A.A. Stickney. 1994. Wildlife studies on the Colville River Delta, Alaska, 1993. Unpublished report prepared for ARCO Alaska, Inc., Anchorage, Alaska.
- Stehn, R. and R. Platte. 2000. Exposure of birds to assumed oil spills at the Liberty Project. Unpublished report prepared for Migratory Bird Management, U.S. Fish and Wildlife Service, Anchorage, Alaska.
- Still, D., B. Little, S.G. Lawrence, and H. Carver. 1994. The birds of Blyth Harbour. Pages 241-248 in: G. Elliot, ed. *Wind energy conversion 1994. Proceedings of the 16th British Wind Energy Association Conference, Sterling, 15-17 June 1994.* Mechanical Engineering Pubs. Ltd., London.
- Stout, J. and G.W. Cornwell. 1976. Nonhunting mortality of fledged North American waterfowl. *J. Wildl. Manage.* 40:681-693.
- Suydam, R., L. Quakenbush, M. Johnson, J.C. George, and J. Young. 1997. Migration of king and common eiders past Point Barrow, Alaska, in spring 1987, spring 1994, and fall 1994. Pages 21-28 in D. Lynne Dixon (ed.). *King and common eiders of the western Canadian Arctic.* Canadian Wildlife Service Occasional Paper #94, Ottawa.
- Swales, M.K. 1964. The sea-birds of Gough Island. *Ibis* 107: 17-42.
- Taylor, E. J. 1986. Foods and foraging ecology of oldsquaws (*Clangula hyemalis* L.) on the Arctic Coastal Plain of Alaska. M.S. Thesis, University of Alaska, Fairbanks. 130 pp.
- Telfer, T.C., J.L. Sincock, G.V. Byrd, J.R. Reed. 1987. Attraction of Hawaiian seabirds to lights: Conservation efforts and effects of moon phase. *Wildl. Soc. Bull.* 15:406-413.

- Troy Ecological Research Associates. 1995. Distribution and abundance of spectacled eiders in the vicinity of Prudhoe Bay, Alaska, 1991-1993. Unpublished report prepared for BP Exploration (Alaska) Inc., Anchorage, Alaska.
- Troy Ecological Research Associates. 1997. Distribution and abundance of spectacled eiders in the vicinity of Prudhoe Bay, Alaska: 1996 Status Report. Unpublished report prepared for BP Exploration (Alaska) Inc., Anchorage, Alaska.
- Troy Ecological Research Associates. 1999. Spectacled eiders in the Beaufort Sea: Distribution and timing of use. Unpublished report prepared for BP Exploration (Alaska) Inc., Anchorage, Alaska.
- U.S. Fish and Wildlife Service. 1996. Spectacled eider recovery plan. Unpublished report prepared for the U.S. Fish and Wildlife Service by the Spectacled Eider Recovery Team, Anchorage, Alaska. 157 pp.
- Warnock, N.D., and D.M. Troy. 1992. Distribution and abundance of spectacled eiders at Prudhoe Bay, Alaska: 1991. Unpublished report prepared for BP Exploration (Alaska) Inc., Environmental and Regulatory Affairs Department, Anchorage, Alaska, by Troy Ecological Research Associates, Anchorage, Alaska. 21 pp.
- Weir, R.D. 1976. Annotated bibliography of bird kills at man-made obstacles: A review of the state of the art and solutions. Unpublished report prepared for Department of Fisheries & Environment, Canadian Wildlife Service-Ontario Region.
- Woodby, D.A., and G.J. Divoky. 1982. Spring migration of eiders and other waterbirds at Point Barrow, Alaska. *Arctic* 35(3): 403-410.
- World Wildlife Fund. 1996. Collision course: the hazards of lighted structures and windows to migrating birds. World Wildlife Fund Canada and Fatal Light Awareness Program. 46 pp.

ATTACHMENT 1

Consultation History

3/31/98	MMS transmits request to Service for concurrence on species list for the Liberty project.
5/8/98	Service provides species list to MMS.
11/6/98	MMS designates BPXA as a non-Federal representative for informal consultation.
12/1/00	MMS transmits request to Service for concurrence on revisions to update species list.
2/1/01	Service provides updated species list.
2/28/01	Service receives MMS request to initiate formal section 7 consultation for proposed Liberty project.
3/12/01	Service receives supplemental information for the consultation from MMS.
3/12-7/24/01	Numerous phone calls and emails between the Service, MMS, and others.
7/?/01	Service transmits draft biological opinion to MMS.
11/30/01	Service provides revised Reasonable and Prudent Measures to MMS and BPXA for review.
12/03/01	MMS notifies Service that MMS and BPXA approve of revised Reasonable and Prudent Measures.
1/3/02	Service transmits draft Biological Opinion to MMS for comment
1/9/02	MMS transmits memo to FWS indicating MMS has no further comments on draft Biological Opinion

APPENDIX D

EIS SUPPORTING DOCUMENTS

- D-1 Economic Analysis of the Development Alternatives for the Liberty Prospect, Beaufort Sea, Alaska (MMS, 2000)**
- D-2* An Engineering Assessment of Double-Wall Versus Single-Wall Designs for Offshore Pipelines in an Arctic Environment (C-Core, 2000)
- D-3* Assessment of Extended-Reach Drilling Technology to Develop the Liberty Reservoir from Alternative Surface Locations (MMS,2000)
- D-4* Final Report: Independent Evaluation of Liberty Pipeline System Design Alternatives – Summary (Stress, 2000)
- D-5* Evaluation of Pipeline System Alternatives: Executive Summary (INTEC, 2000)
- D-5A* Response to MMS, Agency and Stress Engineering Comments – Liberty Pipeline System Alternatives (prepared by INTEC)
- D-6* Independent Risk Evaluation for the Liberty Pipeline – Executive Summary (Fleet, 2000)
- D-7 State Fire Marshal's Position on Double-Walled Piping for Hazardous Liquid Systems (California State Fire Marshal, Pipeline Safety Division, October 30, 1998)**
- D-8 Survey of Proposed Liberty Project Gravel Source Areas for Evidence of Bird and Mammal Use (MMS, 2001)**
- D-9** Numerical Modeling of the Fate of Suspended Sediments Resulting from the Liberty Project

**Economic Analysis of the Development Alternatives for the
Liberty Prospect, Beaufort Sea, Alaska (MMS, 2000)**

Appendix D-1

Economic Analysis of the Development Alternatives for the Liberty Prospect, Beaufort Sea, Alaska

James D. Craig, Minerals Management Service, Alaska, February 24, 2000

Purpose: The Environmental Impact Statement (EIS) for the Liberty prospect evaluates several alternatives in the location and design of the facility in addition to the original Proposal submitted by BPXA in their Development and Production Plan (BPXA, 1998a). Many possible alternatives have been proposed by outside groups to mitigate the potential environmental effects of the project; however, the analyses contained in the Liberty EIS should focus on realistic development options. A key working assumption is that the alternatives considered in the Liberty EIS should be technically and economically feasible.

The present study conducts an economic analysis of seven potential alternatives for the Liberty Project. A basic assumption is that uneconomic projects would not be pursued and, therefore, they would not cause lasting environmental effects. This study is not intended to replicate the economic evaluation of the Liberty Project by BPXA or its contractors. The analysis discussed here merely expands the scope to include evaluations of other potential alternatives within a common conceptual framework. From this, nonviable options will be screened out. This exercise will, we hope, lead to a more realistic EIS for the Liberty Project.

Methodology: The economic analysis for the Liberty Project uses a basic Discount Cash Flow (DCF) model written in Excel97. The analysis schedules the expenses and income associated with the project and adjusts the future cash flow to Net Present Value (NPV) using discounting/deflation factors. Various output parameters define the value to the investor (BPXA) and the potential income to government from taxes and royalty payments. The total value of the project to all parties should be considered when evaluating the various alternatives for development.

Input parameters to the DCF model were compiled from Federal, State, and industry sources. The costs and scheduling for development infrastructure are based largely on data supplied by BPXA in their Development and Production Plan (BPXA, 1998a). These data are supplemented by references from the State of Alaska, Departments of Revenue and Natural Resources. Data supplied by BPXA was verified by comparison to the proprietary cost database compiled by the Minerals Management Service for resource assessments and tract-bid evaluations. Development costs for the other alternatives are scaled from the baseline cost data from BPXA.

A. DEFINITIONS AND ASSUMPTIONS FOR THE ECONOMIC MODEL

1. Economic Parameters

a. Base Year

The Base Year is defined as of January 1, 2000. This is the “present” in the sense of Net Present Value (NPV) analysis. End-of-year accounting is used for the expenses (or income) during each year of the project.

b. Geologic Probability

The likelihood that petroleum is present in the prospect is given as a percentage probability. A confirmed discovery has a probability is 1.0. The results of the economic analysis are reported as unrisks and risks values. For Liberty, the geologic probability is 1.0 and, therefore, unrisks and risks values are equal.

c. Barrels-of-Oil Equivalency Conversion Factor

This parameter is used to convert natural gas units into barrels-of-oil equivalency (BOE) units. The conversion factor used is 5.62 thousand cubic feet per barrel. We assume that natural gas has a Btu (British thermal unit) yield of 1,000 Btu per cubic foot (1.0 million Btu per 1.0 thousand cubic feet). The present study does not report BOE units and, therefore, the BOE conversion factor is not relevant.

d. Inflation Rate

Inflation is the increase in the cost of goods and services as the economy grows. Inflation rate is used to increase the input values given in Base Year dollars to the actual (nominal) dollars “as-spent” or “as-received” in the future. TableD-1-1 provides conversion factors from past years to adjust to the beginning of the Base Year (2000). This is mainly used to define sunk costs or past oil prices in relation to 2000\$. For example, an oil price of \$18.00 in 1997 would be equivalent to \$19.12 in 2000\$ ($\$18.00 \times 1.062$).

Nominal development costs and petroleum prices are inflated into the future at the same rate. Generally, the model assumes no real change (increase above inflation rate) for either costs or prices. Estimates for inflation are taken from the recent Energy Information Agency forecast (AEO-2000, Overview, Table 1), where annual inflation for the period 1998-2020 is expected to range from 1.7-2.9%, with a reference case of 2.3%.

e. Discount Rate

Discount rates are used to account for the time value of money. In DCF models, the discount rate converts future cash flows to equivalent present values. Discount rates reflect the value of capital tied up in an investment and can be used to compare alternative investments. Discount rates also can be viewed as minimum return (or “hurdle rates”) to define a comfortable breakeven level for the investment.

As tax regulations can vary widely between different areas, discount rates can be adjusted to reflect after-tax investment returns. A downward adjustment of 2-4% commonly is

used to convert before-tax to after-tax discount rates. The model inputs discount rates in real (constant\$) terms and, therefore, inflation is subtracted from reported nominal discount rates.

The basic component of the discount rate is the cost of capital. The weighted average cost of capital (WACC) for oil and gas investments has averaged about 10% in recent years (reported as a nominal, before-tax value). Risk premiums typically are added to the WACC to provide a margin on the breakeven return. Minimum risk premiums used by the industry generally are 3-4% higher than the WACC. Standard risk premiums are 6-8% higher than the WACC. Maximum risk premiums could range upwards of 10% or higher (Gustavson, 1999; Miller, 1999). Risk premiums provide a margin for circumstances that are uncertain, including field performance (production rates, cost overruns), market factors (liquidity, future prices), and political risk (taxation, delays).

The following assumptions were used to define real, after-tax discount rates. The minimum discount rate is assumed to be the WACC (10%) plus a 3% risk premium, minus tax (2%) and inflation adjustments (2.3%), resulting in a real, after-tax minimum discount rate of 8.7%. The reference discount rate is defined by the WACC (10%) plus a 7% premium, minus tax (2%) and inflation adjustments (2.3%), resulting in a real, after-tax discount rate of 12.7%. The maximum discount rate is defined by the WACC (10%) plus a 10% risk premium, minus tax (2%) and inflation adjustments (2.3%), resulting in a real, after-tax discount rate of 15.7%. In the DCF calculations, inflation rate is combined with real discount rates, producing overall discounting factors equal to 11.2%, 15.3%, and 18.4%.

f. Oil Prices

Commodity prices are a key parameter in this economic analysis. More than any single variable, future oil prices will determine the profitability of the Liberty Project. Unfortunately, accurate predictions of oil prices decades into the future are impossible. This fact does not, however, inhibit numerous organizations from making price forecasts. The forecasting uncertainties are reflected in the wide range of future petroleum prices reported by various groups (Energy Information Agency, 1999).

A standard reference for energy related forecasts is the Annual Energy Outlook published by the Energy Information Agency (Energy Information Agency, 1999). The current reference (AEO-2000) provides oil and gas price forecasts bracketed by the range between Low-price, Reference, and High-price cases. A more detailed discussion of petroleum prices is given later in this report.

It is important to note that prices can be reported in either constant dollars (also referred to as “real dollars”) or as nominal dollars (also referred to as actual dollars or

“money-of-the-day”). In the current model, prices are input as Base Year dollars (2000\$). Future nominal prices can include inflation as well as real (above inflation) changes in prices. Past petroleum prices are adjusted to 2000\$ using CPI factors published by the Bureau of Labor Statistics (Bureau of Labor Statistics, 2000).

g. Price adjustment of Alaska North Slope Crude Oil in the West Coast Market

The price data reported by the Energy Information Agency is reported as World Oil prices, which are a composite of refiner acquisition costs for a market basket of domestic and foreign crude oil supplies. Relative to World Oil, Alaska North Slope crude oil (ANS) generally is sold at a lower price because of quality differences. In its primary market, the U.S. west coast, ANS competes with local (California) production and foreign suppliers. Approximately 90% of North Slope oil production is shipped to the west coast where ANS comprises about 50% of the refinery runs.

The underlying data compares the average market price (in money of the day) between imported crude oil to the U.S. and ANS (Table D-1-2). In the period 1982-1998, the price difference between ANS and a market basket of imports averaged -\$0.66 per barrel. Price adjustments for various crude oils sold to refineries on the west coast are published by Chevron Products Company. Using the Chevron pricing formula (-\$0.15/API degree below 34°, and ANS gravity of 28°) would yield a \$1.15-per-barrel price adjustment for ANS in the west coast market. If we average the historical ANS price adjustments (-\$0.66 per barrel) and current Chevron market guidelines (-\$1.15 per barrel), a value of -\$0.90 per barrel is obtained. Thus, a World Oil market price of 18.00 per barrel would be equivalent to an average landed west coast ANS price of \$17.10.

h. Quality Bank Adjustment for North Slope Crude Oil

A local North Slope price adjustment is also made for individual oils contributing to ANS stream transported by the Trans-Alaska Pipeline System. A component analysis of each oil stream is priced according to the latest spot prices on the west coast to calculate the value correction relative to the standard ANS composition. This method is termed Quality Bank Adjustment (QBA) and has replaced the API-gravity-based pricing system used in the past.

Because the QBA price-correction methodology is nearly impossible to replicate, a price correction for Liberty oil is estimated using the Endicott field. This is a reasonable assumption, because these two oil accumulations have similar API gravity (22° for Endicott; 25° for Liberty), contained in equivalent reservoirs (Kekiktuk formation), at similar subsurface depths (10,200 ft for Endicott; 11,050 ft

for Liberty). Data from Fineberg (1998) reports a QBA for Endicott of -\$0.29 per barrel. Because Liberty is slightly lighter, its QBA is estimated at -\$0.25 per barrel.

The QBA price correction (-\$0.25) is added to the west coast price differential for ANS (-\$0.90) to arrive at the total price adjustment of -\$1.15 for Liberty crude oil compared to World Oil.

i. North Slope Gas Prices

Natural gas production on the North Slope is a by-product of oil production. There is no delivery system to transport gas to outside markets, and gas production is either used as fuel for facilities or is reinjected into reservoirs to increase oil recovery. Because some North Slope fields have a surplus of available gas, gas is transported off-lease and sold to neighboring units to support their oil-recovery programs. Off-lease gas sales also are made to North Slope facilities, such as the Trans-Alaska Pipeline System pump stations, where it is used as fuel. Both the State and Federal Government collect royalty payments for produced gas that is consumed or transported off-lease for sale. Reinjecting gas does not incur a royalty.

The North Slope is a closed market for natural gas sales, because there is no competition with gas production from other regions. This situation requires an alternate method to calculate gas value for royalty and income tax purposes. Because there is no formal arrangement for gas valuation from Federal lands in northern Alaska, the State royalty valuation formula is adopted for the Liberty analysis. Gas prices are tied to landed ANS oil prices by the following formula:

$$\text{Gas price} = \$0.74/\text{Mcf} \times (\text{landed ANS oil price}/\$16.16)$$

For example, an ANS oil price of \$18.00 (landed on the west coast) would translate to a North Slope gas price of \$0.82 per thousand cubic feet.

2. Tax and Royalty Inputs

a. Tangible Portion of Costs

Tangible assets include facilities, equipment, wells, pipelines, and other components of the development project that can be appraised by inspection. Tangible assets are depreciated for tax purposes according to State and Federal regulations. The variables used for the tangible portion of development items are typical to oil and gas industry.

Intangible costs comprise the remainder of the capital investments in a project (total costs minus tangible portion). Intangible costs (or IDC) are expenditures that ordinarily do not have salvage value, such as logistics, rigs costs,

supplies, and these costs can be deducted in the year spent. The 1986 revisions to the Internal Revenue Service tax law now require that 30% of the IDC must be amortized over a 5-year period. The present version of the economic spreadsheet does not separate the 30% IDC fraction. Instead, adjustments are made to the tangible inputs to accommodate the 30% IDC fraction. For example, if the normal tangible allowance for a development well is 30% tangible and 70% is intangible, we would add the 30% IDC (or 21%) to the tangible fraction to give an input tangible fraction of 51%.

b. Accelerated Cost Recovery Schedule

The Accelerated Cost Recovery Schedule (ACRS) is a timetable defined by the Internal Revenue Service that specifies the annual allowable deductions for tangible expenses, where total recovery is obtained over an 8-year period. We recognize that IDC expenses are deductible on a 5-year schedule, but this has a minor effect in the cash-flow calculations.

c. Federal Tax Rate

According to Internal Revenue Service regulations, the nominal tax rate for corporations is 35%. This rate is applied to net taxable income after costs, royalty, tangible/intangible deductions, and State/local taxes (if applicable) have been subtracted. The tax calculations are specific to the individual project and do not account for the company's actual tax position.

d. State Tax Rate

The applicability of Alaska State income tax for a Federal outer continental shelf project is not clear. Normally, states do not collect corporate income taxes directly from projects on the Federal outer continental shelf, regardless of the support infrastructure that may lie on adjacent State lands. For alternatives where the Liberty production facility is located on a Federal outer continental shelf lease, it is assumed that no State corporate income tax would be paid directly from the Liberty Project. For alternatives where the Liberty production facility is located on State land, it is assumed that State income tax would be collected. **This assumption does not constitute a legal opinion.** The overall tax burden on the project remains approximately the same, as State taxes are deducted from taxable income before Federal taxes are calculated.

State income taxes are calculated using a complex formula that prorates a specific company's activities within the State in comparison to its worldwide activities (sales, production, and assets). Because these data are not available to the public, previous studies simply have assumed an effective

tax rate of 3%. In all likelihood, average tax rates range between 3-4% in recent years (State of Alaska, Dept. of Revenue, pers. commun.). State severance tax is not included in the present model, because Liberty oil lies under Federal land. Other State taxes are inconsequential and are ignored.

e. Property Tax

Property tax is paid to the State of Alaska for infrastructure located on State lands (including offshore submerged land). The standard tax rate is 2% (20 mils) calculated on the current year tax base (depreciated value of tangible assets). Onshore pipelines or facilities are assumed to include property taxes in their tariffs. A separate spreadsheet is used to calculate ad valorem (property) tax based on the tangible portion of development items.

f. Royalty

Royalty from production is paid to the Federal Government following the conditions of the lease. In the case of Liberty, the royalty rate is fixed at 12.5% of gross revenue (both oil and gas sales) minus transportation costs.

3. Infrastructure Costs

Facilities and associated development costs are reported herein as "as-spent" dollars. However, the model inputs are given in Base Year dollars. Because of inflation, as-spent costs will be somewhat higher in the future than the inputs in Base Year dollars. Some iteration is required to adjust the desired as-spent amounts from constant dollar input variables. End-of-year accounting is used throughout the DCF model.

a. Sunk Costs

Sunk costs are past expenses associated with the Liberty Project. Allowable sunk costs begin with issuance of the outer continental shelf Y1650 lease (October 1, 1996) and end at year-end of 1999. Lease acquisition costs (bonus bid in outer continental shelf Sale 144) and the Liberty exploration well cost are the major items in sunk costs. Expenses associated with seismic surveys, tract rental, and environmental and engineering studies in support of permitting requirements also are allowable, if they occurred within this period. Sunk costs are separated into lease (bonus bid and rental) and appraisal (wells and studies). Sunk costs are inflated to the Base Year from the year spent using inflation factors of the Bureau of Labor Statistics (2000).

b. Well Costs

Well costs include all expenses associated with planning, drilling, evaluation, and completion activities. Well costs are not itemized by individual wells; rather, the total cost of the drilling program is divided into the number of wells planned to calculate an average well cost. In the case of shallow, waste-injection wells, two wells are counted as one deep well. For example, if the total cost of the drilling program is estimated to be \$80 million and includes 20 wells, the average well cost is \$4.0 million per well.

Development wells include both production and injection wells. According to general definitions, conventional development wells vary in trajectory from vertical to sail angles approaching 60 degrees. There is a wealth of experience in drilling conventional wells and, therefore, costs estimates are better constrained.

A new class of wells called extended-reach wells are used increasingly by industry to reach subsurface targets when surface constraints restrict the optimum location of facilities directly over oil pool. Extended-reach wells are defined as having departure ratios (or horizontal reach to vertical depth) of greater than 1.5. For example, a well drilled to 8,000 feet (true vertical depth) to reach a reservoir target 12,000 feet away from the rig location would be considered an extended-reach well (departure ratio of 1.5).

Extended-reach drilling wells are inherently more expensive, because they require larger rigs and take longer to drill (higher rig costs), use more materials (drilling fluids, casing, drill bits), and usually encounter more problems while drilling (wellbore instability). The first extended-reach wells in a field could cost twice as much (per foot drilled) and take three times as long as later extended-reach wells drilled in the same field. Later extended-reach wells in the field could have costs and drilling times approaching conventional wells on a measured depth (per-foot drilled) basis. For example, if the cost for a conventional well drilled to 12,000 feet (measured depth) is \$3 million, the cost of the first extended-reach well drilled to 24,000 feet (measured depth) could be \$12 million ($\$3 \text{ million} \times 24,000/12,000 \times 2$). In the later stages of the learning curve, the cost for the same extended-reach well could be as low as \$6.0 million ($\$3 \text{ million} \times 24,000/12,000$) with a learning curve increasing the efficiency of operations.

Although the costs of rig time and materials can be estimated with some degree of confidence, the downhole problems often encountered by extended-reach wells are difficult to anticipate. Drilling problems tend to increase as the drilled distance and the departure ratio increase. There are little data available for recent extended-reach wells. Even when available, these data may not be applicable to a new field because drilling conditions often differ in each area.

For the present study, we used the same adjustment factors (scaled to the departure ratio) to estimate potential cost and

time overruns for extended-reach wells. These factors apply to the average cost per-well over the entire drilling program and may not accurately represent the higher costs of the first extended-reach wells attempted. A learning curve and technology advancement are factored in to the adjustment factors shown below.

Departure Ratio	Cost Factor
2	1.2
3	1.4
4	1.6
5	1.8
6	2.0
7	2.2
8	2.4

For example, a group of extended-reach wells with a measured depth of 24,000 feet drilled to a 12,000 foot reservoir (departure ratio = 1.18) would cost an average of \$7.1 million per well ($\$3 \text{ million} \times 24,000/12,000 \times 1.18$).

As discussed earlier, extended-reach wells cost more and take longer to drill. Adjustment factors were used in the present analysis to provide allowances for slower drilling rates in longer wells. The same adjustments are used to adjust the drilling schedules for alternatives requiring long-reach wells. For example, if the average time required to drill and complete a conventional well to 13,000 feet (measured depth) is 28 days, the time required for an extended-reach well to 26,000 feet measured depth (22,500 feet reach) would be 66 days ($28 \times 26,000/13,000 \times 1.18$). Increases in drilling time slow the production from a field by stretching out the development drilling schedule and lowering peak production rate. Scheduling delays affect the cash flow and overall profitability of fields.

It is important to recognize that the current world record extended-reach well (Wytch Farm, M-16SPZ) has a drilled depth 37,007 feet and a depth ratio of 6.55. This world record is considerably longer (by more than 13,000 feet) than the current record on the North Slope (Niakuk, NK-11A) with a drilled depth of 23,885 feet and a depth ratio of 1.96. Recent Niakuk wells (NK-41 and NK-11A) are North American extended-reach drilling records. Several extended-reach wells also have been drilled in the Milne Point field to reach more than 18,000 feet with higher departure ratios (2.7). Each field in each area may have unique constraints with respect to the geology, costs, and well productivity, which will determine the feasibility of extended-reach wells as a development strategy.

c. Platform Cost

All costs associated with the installation of the production facility are summed under this category, including costs associated with engineering, permits, site preparation, construction of the gravel island, island slope protection, production equipment, onsite infrastructure, logistic support, and project management prior to field startup.

d. Pipeline Cost

All costs associated with engineering, design studies, route surveys, right-of-way, permits, materials, trenching, installation, shore crossings, hook-up, and project management prior to field startup. All pipelines and communication links installed in the alignment are included in the overall costs. The Liberty pipeline is treated as a capital cost and a State property tax is levied on the segment crossing State lands.

e. Shore Base Cost

Costs associated with a new logistic support base, such as airstrips, docks, warehouses, communication systems, and crew quarters, are summed under this category. However, because development logistics for the Liberty project will be handled from existing infrastructure no extra shorebase costs are included in this analysis.

f. Abandonment Cost

Abandonment costs generally include removing production equipment, dismantling onsite facilities, plugging wells, decommissioning the pipeline, and restoration of the site. The abandonment requirements could vary according to regulations in effect at end of production. No implication is made here about the scope of abandonment activities for the Liberty project. Generally, we assume that abandonment costs will equal 5% of total installation costs.

4. Production Scenario

a. Operating Costs

All facility costs associated with production are included as operating costs. Operating costs begin with production startup and generally include facilities maintenance and repair, fuel, labor, supplies, well workovers, pipeline inspection and maintenance, and project management. Operating costs are scaled into two components; a variable component tied to oil and gas production rates, and a fixed component tied to well number. The fixed component reflects the overall size of the production facility.

b. Transportation Costs

Transportation costs are included as tariffs. Following past production history, we assumed that oil is delivered to U.S. west coast markets through the existing TAPS and tanker systems. Sales oil first moves through the Liberty pipeline.

No tariff is set on this pipeline (for Liberty oil) because the pipeline cost is covered as a capital investment and operating costs are included under facility operating costs.

Feeder pipelines move the Liberty oil production to Pump Station 1 of TAPS. The first feeder pipeline segment is the Badami pipeline, and tariffs were estimated on per-mile basis. A tariff of \$0.75/bbl is estimated for the western pipeline route for Liberty-Badami. For the eastern connection of Liberty-Badami (4 miles further east), the estimated Badami pipeline tariff is \$1.00/bbl.

The tariff for the Endicott pipeline is (\$0.49/bbl, 1999). A simple per-mile calculation was used to estimate the tariff between the Badami connection and TAPS-1. Because the Badami connection to the Endicott pipeline is approximately half way to TAPS-1, a tariff of \$0.25/bbl is assumed.

Overall, feeder pipeline tariffs for the various alternatives range from \$0.49 to \$1.25 per barrel, and the tariff for the BPX proposal is estimated at \$1.00 per barrel.

The tariff for TAPS was taken from State of Alaska data (State of Alaska, Dept. of Revenue, 1999:Table 15). The TAPS tariff is estimated to be \$2.71 (nominal) in 2000 and then increases to \$3.61 in 2010. This trend can be replicated using a starting tariff of \$2.88 (in 2000) and inflating this nominal tariff at 2.3% in future years.

Alaska North Slope crude oil is shipped by tankers from the TAPS terminus in Valdez to West Coast refineries. Tanker tariffs are also taken from State reports (State of Alaska, Dept. of Revenue, 1999:Table 15). Tanker tariffs are forecast to be flat (nominal\$) until 2004, averaging \$1.47. After that, nominal costs will increase in steps associated with the phase-in of double hull tankers required under OPA90. The forecast tariffs can be replicated using a starting tariff of \$1.58 (in 2000) and inflating the nominal tariff at 2.3% in future years.

Oil and gas transportation was treated differently in the present study. It was assumed that gas would not be sold from the Liberty project. Gas separation, handling, and reinjection costs are included under per-bbl operating costs.

B. ECONOMIC ANALYSIS

1. Overview of Development Alternatives

At the present time, seven potential options are under consideration as alternatives to be analyzed in the Liberty EIS. These possible alternatives include different production facility locations and pipeline routes (Figure D-1).

A fundamental assumption used for the present economic study is that all of the alternatives will recover the same oil

volume (120 MM barrels) as projected in the DDP. Due to the higher costs, some of the options will be much less desirable from an investor's standpoint. Conservation of resources is an important regulatory mandate for oil and gas projects on Federal lands.

a. BPXA Proposal (1)

This alternative includes the construction of an artificial gravel island in the optimal location above the oil reservoir on tract OCS Y1650. A pipeline corridor would connect the offshore installation along a western route to the Badami pipeline onshore. The Badami and Endicott pipeline systems carry sales oil to Pump Station 1 of TAPS (TAPS-1). This alternative is described in detail in the DPP (BPX, 1998).

b. Eastern Pipeline Alternative (2)

This possible alternative maintains the Liberty production facility in the same location, however an alternate route is chosen for the offshore pipeline corridor. It connects to the Badami pipeline approximately 4 miles further east. The Liberty gravel island, production facility, and drilling costs are the same as for Alternative I. The pipeline costs are slightly higher because the distance is longer.

c. Endicott Pipeline Alternative (3)

This possible alternative has the same location for the Liberty production island as Alternative I, but the sales oil pipeline corridor goes west to the satellite drilling island of the Endicott field. The costs for the gravel island, facility, and drilling are the same as Alternative I, but the pipeline costs are slightly higher for this deeper offshore route.

d. Southern Island Alternative (4)

This possible alternative moves the Liberty production island approximately 1 mile south (still on tract Y-1650). The costs for the gravel island and production facility are the same as for Alternative I. The pipeline follows the eastern corridor. Drilling costs increase slightly because longer wells are required to reach the same bottomhole locations as specified in BPXA (1998a).

e. Tern Island Alternative (5)

This possible alternative moves the Liberty production island approximately 1.5 miles east to the former Tern Island site. The remnants of this previous exploration island would be enlarged to create a new production island. The

pipeline corridor follows a different eastern route to landfall, and a 3-mile onshore pipeline connects to the Badami pipeline. The costs to refurbish Tern island are lower than to construct an entirely new island, but drilling costs are higher because longer wells are required to reach the same bottomhole locations.

f. Bottomfast Ice Zone Alternative (6)

This possible alternative moves the location of the Liberty island approximately 4.5 miles south along the western pipeline corridor. This shallow water site is within the bottomfast ice zone, minimizing the risk to the trenched subsea pipeline caused by ice gouging processes. The island construction costs are lower, as the island is located in much shallower water (6 feet as compared to 21 feet). Shorter pipeline distance also translates into lower overall pipeline costs. However, there are much higher drilling costs for wells to reach the same bottomhole locations as specified in BPXA (1998a). Adjustments were also made to the drilling schedule, essentially slowing the drilling and completion rates for extended-reach drilling wells. **It is important to note that all of the required wells from this location are greater in length than record-setting extended-reach drilling wells on the North Slope.**

g. Onshore Drilling Alternative (7)

This possible alternative moves the drilling and production facility to an onshore location approximately 5.5 miles south of the offshore site described in Alternative I. Site preparation costs are lower, but we assume that the layout of the onshore facility will be expanded to resemble the layout of the Badami field (includes an airstrip and dock). Pipeline costs are considerably lower, as there is only a 3 mile onshore pipeline corridor connecting to the Badami pipeline. We include some sunk costs (\$10 million) associated with engineering and environmental studies now unnecessary for this location. Drilling costs are much higher (3.5 times) compared to Alternative I because of the extremely long distances required to reach the same bottomhole locations. Adjustments were also made to the drilling schedule, essentially slowing the drilling and completion rates for extended-reach drilling wells. **All of the required wells greatly exceed the proven capabilities for extended-reach drilling wells on the North Slope, and several of the required wells would qualify as new world records.**

2. Development Costs

A summary of the development costs associated with the possible alternatives is given in Table D-1-3. Several general conclusions are discussed below.

- The potential cost overruns (maximum costs) are greater than the potential low-side estimates (minimum costs). Using the BPXA Proposal as the reference case, the maximum cost is 28% higher than the expected cost, whereas the minimum cost is 8% lower than the expected cost. The largest uncertainties in potential cost overruns are associated with the pipeline (+38%), drilling (+32%), and facilities (+27%) aspects of the Liberty Project.
- There are minor differences in overall costs between most of the possible alternatives. Changing the location of the facility tends to have offsetting cost components. For example, moving the island would decrease the pipeline cost but increase the drilling cost. For Alternatives I through V, the average cost is \$370 million with only a 2% difference around this average. Considering the uncertainties associated with cost estimation, these alternatives are equivalent for practical purposes.
- Two possible alternatives have considerably higher development costs, largely resulting from higher drilling costs for extended-reach drilling wells. The cost differences range from \$76million (Alternative VI) to \$144 million (Alternative VII) higher than the BPXA Proposal (Alternative I). With much higher per-barrel costs, these alternatives would be far less attractive to investors as development options.
- There are significant differences between these development options with respect to feeder pipeline tariffs. The Endicott alternative has the lowest feeder pipeline tariff of \$0.49 per barrel. The BPXA Proposal (Alternative I) and the bottomfast alternative (Alternative VI) have feeder pipeline tariffs of \$1.00 per barrel. The other alternatives (II, IV, and V) have the highest feeder pipeline tariffs of \$1.25 per barrel.

3. Petroleum Price Forecasts

The economic viability of the Liberty Project is determined by the cash flow associated with the project. The development expenses represent the negative cash flow. The positive cash flow is represented by the income stream from production. Production income is determined by both the production profile (rates) and oil prices. High oil prices will support project viability despite higher costs. Conversely, low oil prices could eliminate viability even under expected costs.

Because oil fields can produce for decades, it is important to take a long-term perspective. This means that average prices over the long term are more important than temporary price spikes that may last a few years. With regard to future oil prices, the most important period is early in the production life when flow rates are near maximum. For the Liberty Project, the period from production startup (2003) to the year 2010 is most important to economic viability

because 87% of the reserves will be produced during that time.

Accurately predicting future commodity prices is difficult, and many would say impossible. Very few economic experts predicted the drastic changes in oil prices over the last few years. In late 1996 to early 1997, oil prices were above \$23 per barrel. Two years later (early 1999), oil prices plunged below \$10 per barrel. By September 1999, oil prices rebounded above \$20, reaching prices of \$30 per barrel in early March 2000. Without belaboring the issue, it should be apparent that long-term viability cannot be accurately predicted using a short-term perspective.

For the present economic analysis, the oil price forecasts of two government agencies are compared. One is a Federal agency (Energy Information Agency) and the other is a State agency (Alaska Department of Revenue). The recently published Annual Energy Outlook 2000 (Energy Information Agency, 1999) reports oil prices ranging from a Low oil price scenario to a High oil price scenario, with the expected scenario referred to as the Reference case. The Low oil price case is forecasted to be flat in real terms, with constant\$ prices of \$14.90 (1998\$) extending to 2020. The Reference case begins in 2000 with an oil price of \$21.19 (1998\$) and increases slowly in real terms (0.38% above inflation rate) to a price of \$22.04 in 2020. The High oil price case begins at \$24.23 (1998\$) and increases slowly in real terms (0.74% above inflation) to \$28.04 in 2020. Adjusting these prices to 2000\$ gives a starting price range of \$15.47, \$22.00, and \$25.15 per barrel.

The State of Alaska presents an entirely different picture of future oil prices in their Fall Revenue Sources Book (State of Alaska, Dept. of Revenue, 1999). An abrupt increase in average ANS market price from \$12.70-\$20.11 between 1999 and 2000 is followed by market prices that vary between \$17.69 and \$18.22 (*in nominal dollars*) to the year 2010. This report discusses oil price volatility and concludes that a 60-month moving average provides the most accurate baseline to predict future prices. The Alaska Department of Revenue reports that the median market price for ANS from 1986 to present is \$17.25 (using a 60-month moving average). Based on this trend they present a forecast for nearly flat nominal prices between 2000 and 2010. This represents a significant decrease in value for oil production because the real (constant\$) value for oil will decline at roughly the rate of inflation.

For example, a market price of \$18.20 (in 2010\$) is equivalent to only \$14.50 in 2000\$. Using the Alaska Department of Revenue price path data (discounted at a 2.3% inflation rate) we calculate an average market oil price of \$16.30 (2000\$) for the period of 2000-2010.

Who is right? We favor the Alaska Department of Revenue forecasts, because they are based on actual data for Alaska operations. In previous forecasts, the Energy Information Agency has consistently overestimated future oil and gas prices (Lynch, 1996). This was primarily caused by two

main assumptions: (1) they assumed a real growth in oil and gas prices would accompany the growth of the economy; and (2) they projected current prices into the future from periods that may be anomalous to long-term trends. In contrast, the Alaska Department of Revenue is more conservative and bases their predictions on long-term price averages for ANS in the west coast marketplace.

4. Price Forecasts and Investment Decisions

There is a great deal of uncertainty surrounding future oil prices. No one is more aware of the consequences of inaccurate forecasts than an investor who has committed major sums of money to a new project. Conservative assumptions lead to more prudent investment decisions. Successful investments are expected by both lending institutions and corporate shareholders. An investor could hedge his evaluation of a project by assuming lower prices, higher cost estimates, or adding risk premiums to discount rates.

To define oil prices for the current study, we focused on the period between the present and the year 2010 because the majority of Liberty oil (87%) will be produced during this period. For the year 2010, the Energy Information Agency Reference case forecast (\$21.86 per barrel) is much higher than the Alaska Department of Revenue forecast (\$14.52 per barrel) (both adjusted back to 2000\$). However, the Energy Information Agency Low-price forecast (\$15.51 per barrel) and the Alaska Department of Revenue forecast (\$14.52 per barrel) are closer.

A study of historical oil prices by WTRG Economics (1999) supports using the lower prices rather than the Energy Information Agency Reference case because from 1947-1997 the median crude oil price was \$15.27 (1996\$). Their conclusion was that the oil industry should plan its operations to be profitable overall when oil prices are below \$15.00 (nominal) half of the time. From an investor's standpoint, it is more prudent to assume a conservative price rather than an optimistic price.

For this study, we defined the baseline oil price using the Alaska Department of Revenue price forecast of \$16.30 per barrel and then subtracted the QBA of \$0.25 to calculate a price for Liberty oil at \$16.05 per barrel. For practical purposes, this was rounded to \$16.00 to set the baseline oil price. We assume that these prices are flat in real terms; that is, nominal (market) prices will increase only at the rate of inflation.

Most of the potential alternatives employ conventional technology to develop the Liberty field. Accordingly, cost and scheduling estimates are comfortably bracketed by the range of values used in the model. In contrast, there are large uncertainties associated with the two possible alternatives that relocate the Liberty facility to the

bottomfast-ice zone and onshore sites. Wells from these distances have not been drilled on the North Slope, and there are scarce long-term data to evaluate the serviceability and production performance for extended-reach drilling wells in other areas. While it could be argued that technology advancement will someday allow drilling to these distances in the Liberty area, the undeniable fact remains that such capabilities are speculative at present.

Because drilling is a major component of development cost and oil production provides the income stream for the project, an increase in the discount rate risk premium is warranted to provide a cushion for cost overruns, well completion delays, or lower than expected field performance. For the bottomfast-ice zone and onshore options, we have used a higher discount rate (15.7%) than used for the other potential alternatives (12.7%).

C. MODELING RESULTS

1. Breakeven Prices

As a first check on economic viability, we modeled the breakeven price required for the Liberty Project as defined in the Development and Production Plan (BPXA, 1998a). All input parameters were kept the same while prices were adjusted until NPV=0 was reached (with a 12.7% after-tax discount rate). Using the expected costs (\$364 million; Table D-1-3), the breakeven oil price is \$13.79 per barrel. Using the maximum cost estimates (\$466 million), the breakeven oil price is \$15.52 per barrel. These breakeven prices are 86% and 97% of the reference price (\$16.00 per barrel), reflecting a margin of 14% and 3%, respectively.

It is important to remember that these prices are given in constant 2000\$. Profitability will require higher future market prices (in nominal\$). For example, using a \$13.79 price and 2.3% annual inflation, the market price of Liberty oil would have to be \$17.31 in 2010. The market price forecasted by the Alaska Department of Revenue (1999) for 2010 is \$18.22 per barrel (a 5% margin over the breakeven price). Using the higher breakeven price (reflecting higher development costs), the market price of Liberty oil would have to be \$19.80 (8.7% above the Dept. of Revenue forecast).

2. Economic Analysis of Development Alternatives

Various criteria can be used to evaluate the economic viability of oil and gas development projects. Some of the more common measures of the project cash flow are given in Table D-1-4 and under Results in the summary sheets

(attached). The summary sheets also show cumulative and annual cash flows graphically.

The following evaluation measures define key economic aspects of the Liberty Project:

- *Maximum Negative Cash Flow.* This value is the maximum cumulative expense incurred for the Liberty project. The actual dollar amount is given in after-tax, undiscounted dollars. This is represented by the low spot in the cumulative cash flow plot (see Cash Flow graph).
- *Payout.* This term is defined as the year in which the cumulative cash flow turns from negative to positive. In the Payout year, income completely offsets past expenses. The shorter the Payout period the more attractive the investment because the project is no longer “in the red.”
- *Total Net Cash Flow (also called Actual Value Profit).* This value is the actual net profit earned on the investment in after-tax, undiscounted dollars. This is represented by the flat, late-life portion of the cumulative cash flow curve (see Cash Flow graph).
- *Profit/Investment (P/I) ratio.* This factor can have various definitions, but it is defined here as the ratio of Actual Value Profit to Maximum Negative Cash Flow. Investments that have higher P/I ratios will be more attractive than those with low P/I ratios. Investments with P/I ratios less than 1.0 (where out-of-pocket expenses are greater than future profits) are risky.
- *Net Present Value (NPV).* Actual expenses and income (money-of-the-day) are discounted to present dollars and summed to the net value of the investment. NPV is the most widely-used measure of viability (where $NPV > 0$).

All potential alternatives require large capital commitments by the developer (BPXA), with cumulative negative expenses ranging from \$205-268 million. The onshore alternative (VII) has the lowest negative cash flow, primarily because drilling expenses are stretched out over time and partially offset by production income early in the field life. Normally, lower cumulative negative expenses are preferable because unused funds would be free for other purposes (exploration, lease acquisition, other developments). However, a longer payout time caused by the slower drilling schedule decreases the attractiveness of Alternative VII because the project is “in the red” longer.

Five alternatives have the same Payout year (2005), and Alternatives VI and VII have longer payout times (2007 and 2008). The accelerated drilling and production schedule associated with convention wells equalizes the negative cash flow within 3 years after field startup. If this aggressive schedule cannot be achieved, these five alternatives will have lower NPV than modeled. Payout periods are longer for the alternatives employing extended-reach drilling wells, because their production profiles are stretched out and have lower peak rates.

The Actual Value Profit varies from a high of \$409 million to a low of \$310 million (\$99 million difference). One could assume that an investor would favor the plan with the highest profit. However, note that the highest profit (both actual dollars and NPV) is associated with the Endicott pipeline option (Alternative III), which is \$38 million higher in AVP than the BPXA Proposal.

The Profit/Investment ratio (P/I) is above 1.0 (favorable) for all of the potential alternatives. However, this criteria is somewhat misleading in that the P/I for alternative #7 is comparable to several other alternatives while its NPV is very negative (-\$32 million). There is an \$94 million difference in NPV between Alternative III and Alternative VII with nearly identical P/I ratios. Alternative VII appears comparable, because drilling expenses are stretched out over time and partially offset by production income early in the field life.

The first five potential alternatives have $NPV > 0$ and therefore could be considered commercially viable. However, the difference in NPV between the BPXA Proposal (Alternative I) and the least viable alternative (V) is \$11 million. The last two potential alternatives (VI and VII) have $NPV < 0$ and therefore are nonviable as commercial projects.

The range in NPV to the government varies from \$51-123 million, or \$16 million between the most economically attractive (Alternative III) and least attractive (Alternative V) commercial option. It is important to recognize that the value to government (NPV-GOV) is generally over twice the NPV to the company, and the government does not risk in any capital to gain this income. This fact qualifies the government as a major stakeholder in the profitability of the Liberty Project.

3. Recommendations for the Liberty EIS

Five potential development options are economically viable and could be considered as feasible alternatives for environmental analysis in the Liberty EIS (Alternatives I-V, Table D-1-4). The remaining two potential options are nonviable and should not be considered as feasible alternatives for the Liberty Project.

The Endicott pipeline alternative (II) has the highest actual profit and NPV to both BPXA and the Government. Using only economic criteria, this option is the most attractive alternative for the Liberty Project. However, potential environmental impacts or other corporate objectives could negate the economic advantage of this option.

The BPXA Proposal (Alternative I) is closest in value to the high-ranked Endicott alternative (III), with an NPV \$10.6 million lower.

Three of the other potential alternatives (II, IV, and V) have very similar economics. These options have NPV

approximately \$10 million lower than the NPV of the BPXA Proposal (Alternative I).

Options #6 and #7 (bottomfast-ice zone and onshore sites) are clearly uneconomic and should be excluded from further environmental impact analysis. Their economics are so poor compared to the other alternatives that neither is likely to be accepted by any company as a realistic development option. From a technical standpoint, these alternatives would require drilling far beyond the existing capabilities on the North Slope. It is speculative as to whether the necessary wells could be drilled and successfully managed.

The preceding economic analysis serves as a screen to separate feasible alternatives from nonviable ideas. We should assume that options that are uneconomic will not be pursued, so they will have no environmental impact. Economic analysis should not be the only criteria used to judge project feasibility. Technical and legal aspects should also be considered. Ultimately, private investors will make the final decision of whether or not to develop the Liberty prospect. Mandated alternatives with poor economics are not likely to be accepted, considering the economic risks and competitive opportunities elsewhere. Should this project be abandoned, the government stands to forfeit twice the potential income as the leaseholder.

- Lynch, M.C. 1996. The mirage of higher petroleum prices, *Journal of Petroleum Technology*, February 1996, p. 169-170.
- Miller, R.J. 1999, The cost-of-capital and fair market value discount rates, SPE 52973, In: *Proceedings, 1999 SPE Hydrocarbon Economics and Evaluation Symposium*, 20-23 March, p. 285-293.
- WTRG Economics, 1999, History and analysis of crude oil prices, <http://www.wtrg.com/prices.htm>.

REFERENCES CITED

- Alaska Department of Revenue. 1999. Revenue Sources Book, Fall 1999, Alaska Department of Revenue, (December 1999), <http://www.revenue.state.ak.us>.
- Alaska Department of Revenue. 1999. Historical and Projected Oil and Gas Consumption, Alaska Department of Natural Resources, (May 1999), <http://www.dog.dnr.state.ak.us>.
- Alaska Oil and Gas Conservation Commission. 1998. Statistical Report, 1998, Alaska Oil and Gas Conservation Commission, 3001 Porcupine Drive, Anchorage, Alaska, 99501
- Bureau of Labor Statistics. 2000. Consumer price index- All urban consumers, Bureau of Labor Statistics Data, <http://stats.bls.gov>.
- Energy Information Agency. 1999. Annual Energy Outlook 2000 with Projections to 2020, U.S. Department of Energy, Energy Information Agency, DOE/EIA-0383 (2000), (December 17, 1999), <http://www.eia.doe.gov/oiaf/aeo/index.html>.
- Fineberg, R.A. 1998. How Much Is Enough? Estimated industry profits from Alaska North Slope production and associated pipeline operations, 1993-1998, a preliminary report to Oilwatch Alaska.
- Gustavson, J.B. 1999. Valuation of international oil and gas properties, SPE 52957, In: *Proceedings, 1999 SPE Hydrocarbon Economics and Evaluation Symposium*, 20-23 March, p. 145-151.

Table D-1-1 Inflation Adjustment Factors

Year	CPI Index	Inflation Rate	Factor (%)
1995	152.4		
1996	156.9	0.030	1.093
1997	160.5	0.023	1.062
1998	163.0	0.016	1.038
1999	166.6	0.022	1.022

Source: Bureau of Labor Statistics Data, Consumer Price Index-All Urban Consumers, as of March 6, 2000. Inflation for 1999 is taken from AEO-2000 (Energy Information Agency, 1999).

Table D-1-2 Average Market Price of Imported Crude Oil and Alaska North Slope Crude Oil

Year	Imports	ANS	Difference
1982	\$33.18	\$32.04	(\$1.14)
1983	\$28.93	\$30.31	\$1.38
1984	\$28.54	\$29.26	\$0.72
1985	\$26.67	\$27.89	\$1.22
1986	\$13.49	\$22.03	\$8.54
1987	\$17.65	\$14.98	(\$2.67)
1988	\$14.08	\$16.45	\$2.37
1989	\$17.68	\$14.80	(\$2.88)
1990	\$21.13	\$17.34	(\$3.79)
1991	\$19.06	\$21.72	\$2.66
1992	\$17.75	\$16.88	(\$0.87)
1993	\$15.72	\$17.93	\$2.21
1994	\$15.18	\$14.22	(\$0.96)
1995	\$16.78	\$16.83	\$0.05
1996	\$20.31	\$17.77	(\$2.54)
1997	\$18.11	\$20.85	\$2.74
1998	\$11.84	\$16.03	\$4.19

Data sources: Imports (Energy Information Agency, 1999, in http://eia.doe.gov/pub/oil_gas/petroleum/data_publications/...tables01.tx). ANS (Alaska Department of Revenue, Revenue Sources Book, Spring 1999, Table 18).

Table D-1-3 Summary of Development Costs for the Liberty Alternatives

Component	Cost (millions of \$)		
	Expected	Minimum	Maximum
BPX Proposal (Alt 1)			
Island	50	47	57
Pipeline	52	44	72
Facilities	181	169	230
Drilling	81	76	107
Total	364	336	466
Eastern Pipeline Route (Alt 2)			
Island	50	47	57
Pipeline	57	44	79
Facilities	181	169	230
Drilling	81	76	107
Total	369	336	473
Endicott Pipeline Route (Alt 3)			
Island	50	47	57
Pipeline	58	48	78
Facilities	181	169	230
Drilling	81	76	107
Total	370	340	472
Southern Island Location (Alt 4)			
Island	50	47	57
Pipeline	49	42	68
Facilities	181	169	230
Drilling	93	86	121
Total	373	344	476
Tern Island Location (Alt 5)			
Island	40	37	45
Pipeline	58	44	81
Facilities	181	169	230
Drilling	97	91	128
Total	376	341	484
Bottomfast Ice Zone (Alt 6)			
Island	25	23	28
Pipeline	11	9	13
Facilities	181	169	230
Drilling	223	210	294
Total	440	411	565
Onshore Location (Alt 7)			
Island	35	27	42
Pipeline	9	7	12
Facilities	181	169	230
Drilling	283	263	370
Total	508	466	654
Feeder Pipeline Tariffs (\$ per barrel)			
Alt 1	\$1.00		
Alt 2	\$1.25		
Alt 3	\$0.49		
Alt 4	\$1.25		
Alt 5	\$1.25		
Alt 6	\$1.00		
Alt 7	\$1.25		

Table D-1-4 Summary of Economic Analysis

Alternative	Max Negative Cash Flow (\$ millions)	Payout (yr)	Actual Value Profit (\$ millions)	P/I Ratio	NPV (\$ millions)	NPV-GOV (\$ millions)
1 BPX	(\$261.81)	2005	\$371.55	1.42	\$51.39	\$113.50
2 Eastern pipeline	(\$266.45)	2005	\$348.50	1.31	\$42.52	\$107.95
3 Endicott pipeline	(\$267.51)	2005	\$409.35	1.53	\$62.03	\$123.00
4 Southern Island	(\$258.99)	2005	\$345.22	1.33	\$41.96	\$107.03
5 Tern Island	(\$258.87)	2005	\$343.28	1.33	\$40.00	\$107.20
6 Bottomfast zone	(\$208.93)	2007	\$356.00	1.70	(\$7.53)	\$69.21
7 Onshore	(\$204.97)	2008	\$309.55	1.51	(\$32.15)	\$50.73

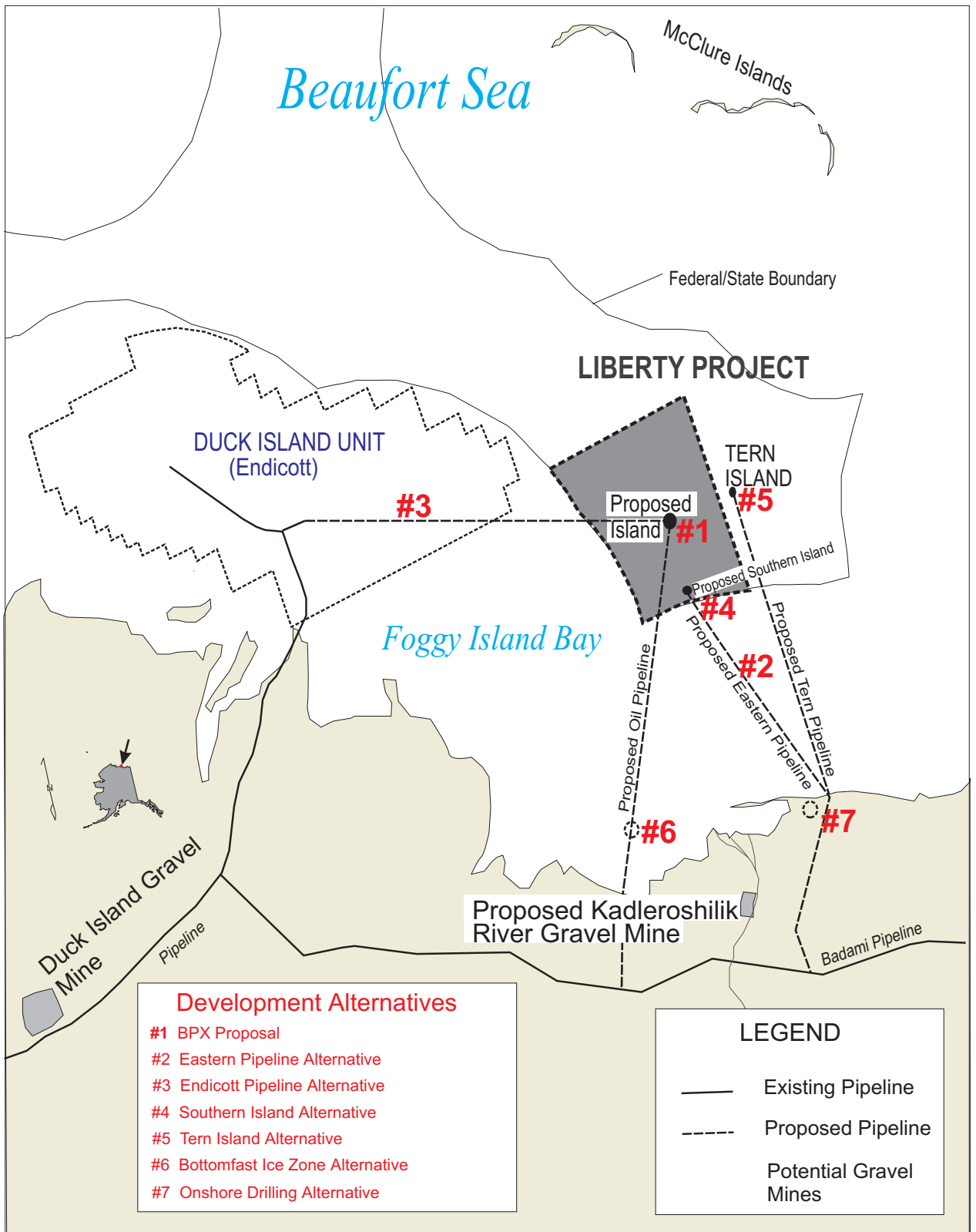

Figure D-1 Overview of Development Alternatives

Project: Liberty	Case (Alternative): BPX proposal
Planning Area: Beaufort Sea	Analyst: Jim Craig
Company: BPX-Alaska	Date of Analysis: 29-Nov-00

Economic Parameters

Base Year: 2000	Suggested Distribution	to be used	Inflation Rate
Geologic Probability (1- Risk): 100%	1.70% 2.30% 2.90%	2.30%	Real, After-Tax Discount Rate: 8.70% 12.70% 15.70%
BOE Conversion Factor (Mcf/bbl): 5.62 Mcf/bbl			Max. gas price as a % of oil price: 100.00%

Oil Price:		Suggested Distribution			to be used
Landed Starting Price (\$/bbl):		\$11.51	\$15.78	\$20.31	\$16.00
Real Price	Period 1 Rate	3.30%	3.40%	4.10%	0.00%
	Period 2 Rate	0.00%	1.80%	2.10%	0.00%
	Period 3 Rate	0.00%	0.70%	0.80%	0.00%
Growth	Period 1 Begin Year				2000
	Period 2 Begin Year				2005
	Period 3 Begin Year				2011

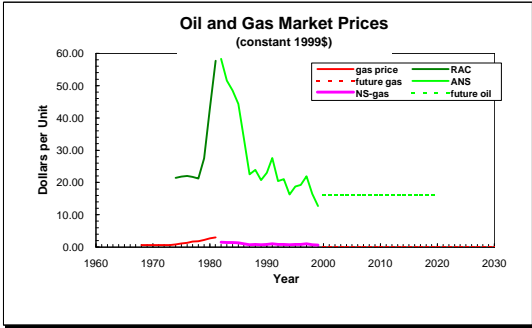

Tax and Royalty Inputs

Tangible Portion of Costs:	with IDC	w/o IDC	ACRS Schedule:	Federal Tax Rate: 35.00%
Lease (bonus bid):	0%	0%	Year 1: 14.29%	State Tax Rate: 0.00%
Delineation/Appraisal (wells & seismic):	0%	0%	Year 2: 24.49%	Property Tax Rate: 2.00% (use AdValorem sheet)
Exploration well converted to producer:	51%	30%	Year 3: 17.49%	
Development Well:	51%	30%	Year 4: 12.49%	Royalty Rate: 12.50%
ERD Well:	51%	30%	Year 5: 8.93%	
Platform & Production Equipment:	72%	60%	Year 6: 8.92%	
New Shorebase:	83%	75%	Year 7: 8.93%	
Pipeline:	100%	100%	Year 8: 4.46%	
Abandonment:	0%	0%		

Infrastructure Costs

Sunk Costs (\$MM):	Platform Cost (\$MM): (Island + Production Facility)	As-Spent Costs (\$MM):
Lease: \$11.80	depth minimum most likely maximum to be used	Shorebase: \$0
Appraisal: \$7.10	0 - 6 ft \$150 \$250.00 \$300.00 \$206.50	Platform: \$231
Well Costs (\$MM/well)	7 - 25 ft \$200 \$270.00 \$340.00 \$220.80	Pipeline: \$52
Exploration (Productive): \$6.60	26 - 50 ft \$225 \$300.00 \$375.00 \$270.00	Drilling: \$81
Development: \$3.38	Pipeline Cost (\$MM):	Abandonment: \$18
ERD well: \$12.05	Unit cost (\$MM/mi): \$6.54	Total Development Cost :
Shorebase (\$MM): \$0.00	Miles: 7.6 (enter in Schedule)	As-spent (\$/bbl): \$3.35
		Constant (\$/bbl): \$2.97

Production Scenario

Operating Costs:	Transportation Costs:	Field Life: 16 years
Variable (per-unit):	Oil: \$5.46 /bbl	Abandonment (\$MM): \$12.00
Oil: \$0.30 /bbl	Gas: \$0.00 /Mcf	
Gas: \$0.00 /Mcf	Oil feeder pipelines: \$1.00 /bbl	National Stockpile
Fixed (facility):	TAPS tariff: \$2.88 /bbl	Imported oil expected to be embargoed (%): 45.40%
(per-well basis) \$0.60 \$MM/well/yr	Tanker tariff: \$1.58 /bbl	Percent of year embargo lasts: 83.33%
Total Operating Cost:	Gas feeder pipeline: 0	NPV Stockpile Reserve Value (\$MM): \$40.14
As-spent: \$2.50 (\$/bbl)	Handling costs: 0	
Constant\$: \$1.97 (\$/bbl)		

Notes

- Enter data in cells with blue fonts.
Cells with black fonts contain calculations or guidelines.
- (1) Costs and prices are input in 2000\$ (blue) and inflated to the year as-spent (black). End-of-year accounting is used.
 - (2) Expenses prior to the Base Year (Sunk costs) are inflated to constant Base Year dollars.
 - (3) Development cost categories include all expenses associated with activity: management, engineering, studies, materials, installation, logistics.
 - (4) Operating costs include all expenses associated with transportation, communication, maintenance, repair, project management, inspections, well workovers, supplies
 - (5) Property tax should be included for all project infrastructure located on State lands (use Ad Valorem sheet).

Summary of Results

	Unrisked		Risked
Estimated Resources:			
Oil (MMbbl):	120.00		120.00
Gas (Bcf):	78.35		78.35
Estimated Values (MMS):			
Net Income (BFIT):	\$746.93		\$746.93
Income to F&S governments:	\$386.06		\$386.06
Taxes:	\$205.00		\$205.00
Royalties:	\$181.06		\$181.06
Net Present Value (MMS):			
NPV of Net Income (BFIT):	\$161.13		\$161.13
NPV Income to F&S governments:	\$113.50		\$113.50
NPV of Taxes:	\$54.53		\$54.53
NPV of Royalties:	\$58.96		\$58.96
NPV of Cash Flow:	\$51.39		\$51.39

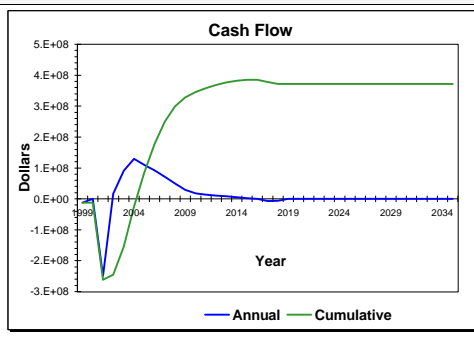

Project: Liberty	Case (Alternative): Eastern Pipeline
Planning Area: Beaufort Sea	Analyst: Jim Craig
Company: BPX-Alaska	Date of Analysis: 29-Nov-00

Economic Parameters

Base Year: 2000	Inflation Rate	Suggested Distribution	to be used
Geologic Probability (1- Risk): 100%	Real, After-Tax Discount Rate:	1.70% 2.30% 2.90%	2.30%
BOE Conversion Factor (Mcf/bbl): 5.62 Mcf/bbl	Max. gas price as a % of oil price:	8.70% 12.70% 15.70%	12.70%
			100.00%

Oil Price:		Suggested Distribution			to be used
Landed Starting Price (\$/bbl):		\$11.51	\$15.78	\$20.31	\$16.00
Real Price	Period 1 Rate	3.30%	3.40%	4.10%	0.00%
	Period 2 Rate	0.00%	1.80%	2.10%	0.00%
	Period 3 Rate	0.00%	0.70%	0.80%	0.00%
Growth	Period 1 Begin Year				2000
	Period 2 Begin Year				2005
	Period 3 Begin Year				2011

Gas Price:		Suggested Distribution			to be used
Wellhead Starting Price (\$/Mcf):		\$0.53	\$0.72	\$0.93	\$0.00
Real Price	Period 1 Rate	3.30%	3.40%	4.10%	0.00%
	Period 2 Rate	0.00%	1.80%	2.10%	0.00%
	Period 3 Rate	0.00%	0.70%	0.80%	0.00%
Growth	Period 1 Begin Year				2000
	Period 2 Begin Year				2005
	Period 3 Begin Year				2011

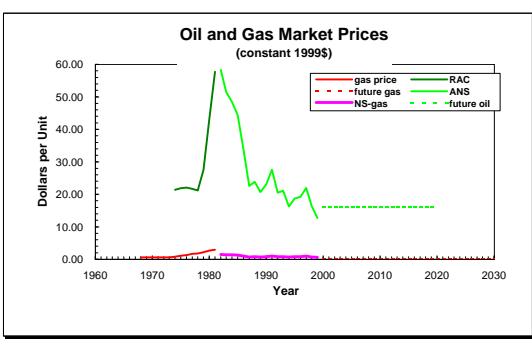

Tax and Royalty Inputs

Tangible Portion of Costs:	with IDC	w/o IDC	ACRS Schedule:	Federal Tax Rate: 35.00%
Lease (bonus bid):	0%	0%	Year 1: 14.29%	State Tax Rate: 0.00%
Delineation/Appraisal (wells & seismic):	0%	0%	Year 2: 24.49%	Property Tax Rate: 2.00% (use AdValorem sheet)
Exploration well converted to producer:	51%	30%	Year 3: 17.49%	Royalty Rate: 12.50%
Development Well:	51%	30%	Year 4: 12.49%	
ERD Well:	51%	30%	Year 5: 8.93%	
Platform & Production Equipment:	72%	60%	Year 6: 8.92%	
New Shorebase:	83%	75%	Year 7: 8.93%	
Pipeline:	100%	100%	Year 8: 4.46%	
Abandonment:	0%	0%		

Infrastructure Costs

Sunk Costs (\$MM):	Platform Cost (\$MM): (Island + Production Facility)	As-Spent Costs (\$MM):
Lease: \$11.80	depth minimum most likely maximum to be used	Shorebase: \$0
Appraisal: \$7.10	0 - 6 ft \$150 \$250.00 \$300.00 \$206.50	Platform: \$231
Well Costs (\$MM/well)	7 - 25 ft \$200 \$270.00 \$340.00 \$220.80	Pipeline: \$57
Exploration (Productive): \$6.60	26 - 50 ft \$225 \$300.00 \$375.00 \$270.00	Drilling: \$81
Development: \$3.38	Pipeline Cost (\$MM):	Abandonment: \$18
ERD well: \$12.05	Unit cost (\$MM/mi): \$6.25	Total Development Cost :
Shorebase (\$MM): \$0.00	Miles: 8.7 (enter in Schedule)	As-spent (\$/bbl): \$3.39
		Constant (\$/bbl): \$3.01

Production Scenario

Operating Costs:	Transportation Costs:	Field Life: 16 years
Variable (per-unit):	Oil: \$5.71 /bbl	Abandonment (\$MM): \$12.00
Oil: \$0.30 /bbl	Gas: \$0.00 /Mcf	National Stockpile
Gas: \$0.00 /Mcf	Oil feeder pipelines: \$1.25 /bbl	Imported oil expected to be embargoed (%): 45.40%
Fixed (facility):	TAPS tariff: \$2.88 /bbl	Percent of year embargo lasts: 83.33%
(per-well basis) \$0.60 \$MM/well/yr	Tanker tariff: \$1.58 /bbl	NPV Stockpile Reserve Value (\$MM): \$40.14
Total Operating Cost:	Gas feeder pipeline: 0	
As-spent: \$2.50 (\$/bbl)	Handling costs: 0	
Constant\$: \$1.97 (\$/bbl)		

Notes

- Enter data in cells with blue fonts.
 Cells with black fonts contain calculations or guidelines.
- (1) Costs and prices are input in 2000\$ (blue) and inflated to the year as-spent (black). End-of-year accounting is used.
 - (2) Expenses prior to the Base Year (Sunk costs) are inflated to constant Base Year dollars.
 - (3) Development cost categories include all expenses associated with activity: management, engineering, studies, materials, installation, logistics.
 - (4) Operating costs include all expenses associated with transportation, communication, maintenance, repair, project management, inspections, well workovers, supplies
 - (5) Property tax should be included for all project infrastructure located on State lands (use Ad Valorem sheet).

Summary of Results

	Unrisked	Risked
Estimated Resources:		
Oil (MMbbl):	120.00	120.00
Gas (Bcf):	78.35	78.35
Estimated Values (MMS):		
Net Income (BFIT):	\$706.47	\$706.47
Income to F&S governments:	\$369.67	\$369.67
Taxes:	\$193.06	\$193.06
Royalties:	\$176.61	\$176.61
Net Present Value (MMS):		
NPV of Net Income (BFIT):	\$146.36	\$146.36
NPV Income to F&S governments:	\$107.95	\$107.95
NPV of Taxes:	\$50.44	\$50.44
NPV of Royalties:	\$57.51	\$57.51
NPV of Cash Flow:	\$42.52	\$42.52

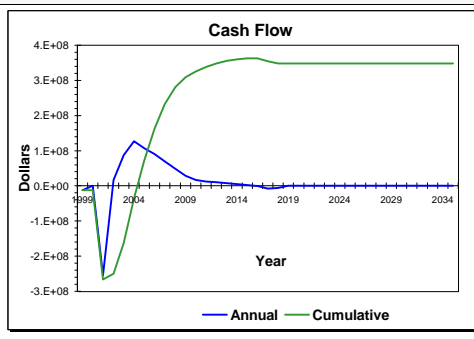

INPUTS

Project: Liberty	Case (Alternative): Endicott Pipeline
Planning Area: Beaufort Sea	Analyst: Jim Craig
Company: BPX-Alaska	Date of Analysis: 29-Nov-00

Economic Parameters		Suggested Distribution			to be used
Base Year:	2000	1.70%	2.30%	2.90%	2.30%
Geologic Probability (1- Risk):	100%				12.70%
BOE Conversion Factor (Mcf/bbl):	5.62 Mcf/bbl				100.00%
		Inflation Rate			
		Real, After-Tax Discount Rate:			
		Max. gas price as a % of oil price:			

Oil Price:		Suggested Distribution			to be used
Landed Starting Price (\$/bbl):		\$11.51	\$15.78	\$20.31	\$16.00
Real Price	Period 1 Rate	3.30%	3.40%	4.10%	0.00%
	Period 2 Rate	0.00%	1.80%	2.10%	0.00%
	Period 3 Rate	0.00%	0.70%	0.80%	0.00%
Growth	Period 1 Begin Year				2000
	Period 2 Begin Year				2005
	Period 3 Begin Year				2011

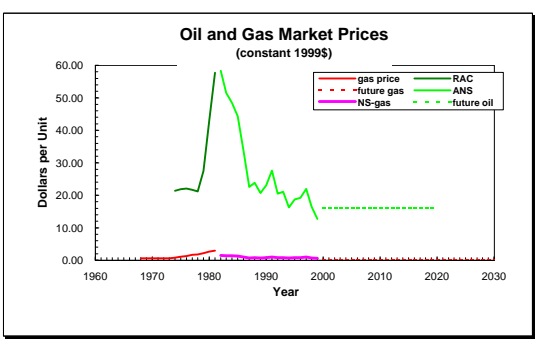

Tax and Royalty Inputs					
Tangible Portion of Costs:	with IDC	w/o IDC	ACRS Schedule:	Federal Tax Rate:	35.00%
Lease (bonus bid):	0%	0%	Year 1:	State Tax Rate:	0.00%
Delineation/Appraisal (wells & seismic):	0%	0%	Year 2:	Property Tax Rate:	2.00% (use AdValorem sheet)
Exploration well converted to producer:	51%	30%	Year 3:	Royalty Rate:	12.50%
Development Well:	51%	30%	Year 4:		
ERD Well:	51%	30%	Year 5:		
Platform & Production Equipment:	72%	60%	Year 6:		
New Shorebase:	83%	75%	Year 7:		
Pipeline:	100%	100%	Year 8:		
Abandonment:	0%	0%			

Infrastructure Costs					
Sunk Costs (\$MM):		Platform Cost (\$MM): (Island + Production Facility)			As-Spent Costs (\$MM):
Lease:	\$11.80	depth	minimum	most likely	maximum
Appraisal:	\$7.10	0 - 6 ft	\$150	\$250.00	\$300.00
Well Costs (\$MM/well)		7 - 25 ft	\$200	\$270.00	\$340.00
Exploration (Productive):	\$6.60	26 - 50 ft	\$225	\$300.00	\$375.00
Development:	\$3.38	Pipeline Cost (\$MM):			
ERD well:	\$12.05	Unit cost (\$MM/mi):			\$7.20
Shorebase (\$MM):	\$0.00	Miles:			7.7 (enter in Schedule)
					Total Development Cost :
					As-spent (\$/bbl):
					Constant (\$/bbl):

Production Scenario					
Operating Costs:		Transportation Costs:		Field Life:	16 years
Variable (per-unit):		Oil:	\$4.95 /bbl	Abandonment (\$MM):	\$12.00
Oil:	\$0.30 /bbl	Gas:	\$0.00 /Mcf	National Stockpile	
Gas:	\$0.00 /Mcf	Oil feeder pipelines:	\$0.49 /bbl	Imported oil expected to be embargoed (%):	45.40%
Fixed (facility):		TAPS tariff:	\$2.88 /bbl	Percent of year embargo lasts:	83.33%
(per-well basis)	\$0.60 \$MM/well/yr	Tanker tariff:	\$1.58 /bbl	NPV Stockpile Reserve Value (\$MM):	\$40.14
Total Operating Cost:		Gas feeder pipeline:	0		
As-spent:	\$2.50 (\$/bbl)	Handling costs:	0		
Constant\$:	\$1.97 (\$/bbl)				

Notes

- Enter data in cells with blue fonts.
 Cells with black fonts contain calculations or guidelines.
- (1) Costs and prices are input in 2000\$ (blue) and inflated to the year as-spent (black). End-of-year accounting is used.
 - (2) Expenses prior to the Base Year (Sunk costs) are inflated to constant Base Year dollars.
 - (3) Development cost categories include all expenses associated with activity: management, engineering, studies, materials, installation, logistics.
 - (4) Operating costs include all expenses associated with transportation, communication, maintenance, repair, project management, inspections, well workovers, supplies
 - (5) Property tax should be included for all project infrastructure located on State lands (use Ad Valorem sheet).

Summary of Results

	Unrisked	Risky
Estimated Resources:		
Oil (MMbbl):	120.00	120.00
Gas (Bcf):	78.35	78.35
Estimated Values (MM\$):		
Net Income (BFIT):	\$813.49	\$813.49
Income to F&S governments:	\$416.05	\$416.05
Taxes:	\$225.92	\$225.92
Royalties:	\$190.13	\$190.13
Net Present Value (MM\$):		
NPV of Net Income (BFIT):	\$180.85	\$180.85
NPV Income to F&S governments:	\$123.00	\$123.00
NPV of Taxes:	\$61.09	\$61.09
NPV of Royalties:	\$61.92	\$61.92
NPV of Cash Flow:	\$62.03	\$62.03

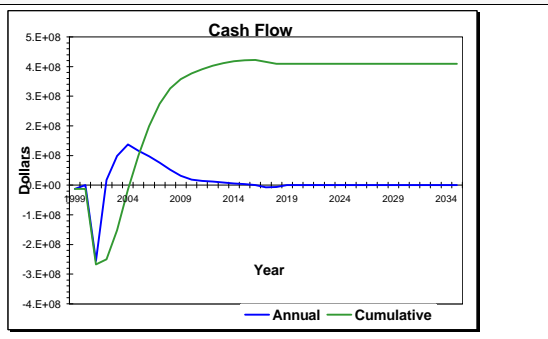

RESULTS

Project: Liberty	Case (Alternative): Southern Island
Planning Area: Beaufort Sea	Analyst: Jim Craig
Company: BPX-Alaska	Date of Analysis: 29-Nov-00

Economic Parameters

Base Year: 2000	Inflation Rate	Suggested Distribution	to be used
Geologic Probability (1- Risk): 100%	1.70%	2.30%	2.90%
BOE Conversion Factor (Mcf/bbl): 5.62 Mcf/bbl	Real, After-Tax Discount Rate:	8.70%	12.70%
	Max. gas price as a % of oil price:	15.70%	100.00%
			12.70%

Oil Price:		Suggested Distribution			to be used
Landed Starting Price (\$/bbl):		\$11.51	\$15.78	\$20.31	\$16.00
Real Price	Period 1 Rate	3.30%	3.40%	4.10%	0.00%
	Period 2 Rate	0.00%	1.80%	2.10%	0.00%
	Period 3 Rate	0.00%	0.70%	0.80%	0.00%
Growth	Period 1 Begin Year				2000
	Period 2 Begin Year				2005
	Period 3 Begin Year				2011

Gas Price:		Suggested Distribution			to be used
Wellhead Starting Price (\$/Mcf):		\$0.53	\$0.72	\$0.93	\$0.00
Real Price	Period 1 Rate	3.30%	3.40%	4.10%	0.00%
	Period 2 Rate	0.00%	1.80%	2.10%	0.00%
	Period 3 Rate	0.00%	0.70%	0.80%	0.00%
Growth	Period 1 Begin Year				2000
	Period 2 Begin Year				2005
	Period 3 Begin Year				2011

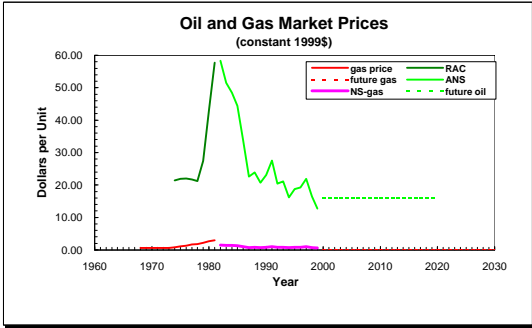

Tax and Royalty Inputs

Tangible Portion of Costs:	with IDC	w/o IDC	ACRS Schedule:	Federal Tax Rate: 35.00%
Lease (bonus bid):	0%	0%	Year 1: 14.29%	State Tax Rate: 0.00%
Delineation/Appraisal (wells & seismic):	0%	0%	Year 2: 24.49%	Property Tax Rate: 2.00% (use AdValorem sheet)
Exploration well converted to producer:	51%	30%	Year 3: 17.49%	Royalty Rate: 12.50%
Development Well:	51%	30%	Year 4: 12.49%	
ERD Well:	51%	30%	Year 5: 8.93%	
Platform & Production Equipment:	72%	60%	Year 6: 8.92%	
New Shorebase:	83%	75%	Year 7: 8.93%	
Pipeline:	100%	100%	Year 8: 4.46%	
Abandonment:	0%	0%		

Infrastructure Costs

Sunk Costs (\$MM):	Platform Cost (\$MM): (Island + Production Facility)	As-Spent Costs (\$MM):
Lease: \$11.80	depth minimum most likely maximum to be used	Shorebase: \$0
Appraisal: \$7.10	0 - 6 ft \$150 \$250.00 \$300.00 \$206.50	Platform: \$231
Well Costs (\$MM/well)	7 - 25 ft \$200 \$270.00 \$340.00 \$220.80	Pipeline: \$49
Exploration (Productive): \$6.60	26 - 50 ft \$225 \$300.00 \$375.00 \$270.00	Drilling: \$93
Development: \$3.88	Pipeline Cost (\$MM):	Abandonment: \$18
ERD well: \$12.05	Unit cost (\$MM/mi): \$6.25	Total Development Cost:
Shorebase (\$MM): \$0.00	Miles: 7.5 (enter in Schedule)	As-spent (\$/bbl): \$3.42
		Constant (\$/bbl): \$3.04

Production Scenario

Operating Costs:	Transportation Costs:	Field Life: 16 years
Variable (per-unit):	Oil: \$5.71 /bbl	Abandonment (\$MM): \$12.00
Oil: \$0.30 /bbl	Gas: \$0.00 /Mcf	National Stockpile
Gas: \$0.00 /Mcf	Oil feeder pipelines: \$1.25 /bbl	Imported oil expected to be embargoed (%): 45.40%
Fixed (facility):	TAPS tariff: \$2.88 /bbl	Percent of year embargo lasts: 83.33%
(per-well basis) \$0.60 \$MM/well/yr	Tanker tariff: \$1.58 /bbl	NPV Stockpile Reserve Value (\$MM): \$40.14
Total Operating Cost:	Gas feeder pipeline: 0	
As-spent: \$2.50 (\$/bbl)	Handling costs: 0	
Constant\$: \$1.97 (\$/bbl)		

Notes

- Enter data in cells with blue fonts.
 Cells with black fonts contain calculations or guidelines.
- (1) Costs and prices are input in 2000\$ (blue) and inflated to the year as-spent (black). End-of-year accounting is used.
 - (2) Expenses prior to the Base Year (Sunk costs) are inflated to constant Base Year dollars.
 - (3) Development cost categories include all expenses associated with activity: management, engineering, studies, materials, installation, logistics.
 - (4) Operating costs include all expenses associated with transportation, communication, maintenance, repair, project management, inspections, well workovers, supplies
 - (5) Property tax should be included for all project infrastructure located on State lands (use Ad Valorem sheet).

Summary of Results

	Unrisked	Risked
Estimated Resources:		
Oil (MMbbl):	120.00	120.00
Gas (Bcf):	78.35	78.35
Estimated Values (MMS):		
Net Income (BFIT):	\$702.31	\$702.31
Income to F&S governments:	\$367.15	\$367.15
Taxes:	\$190.53	\$190.53
Royalties:	\$176.61	\$176.61
Net Present Value (MMS):		
NPV of Net Income (BFIT):	\$145.46	\$145.46
NPV Income to F&S governments:	\$107.03	\$107.03
NPV of Taxes:	\$49.52	\$49.52
NPV of Royalties:	\$57.51	\$57.51
NPV of Cash Flow:	\$41.96	\$41.96

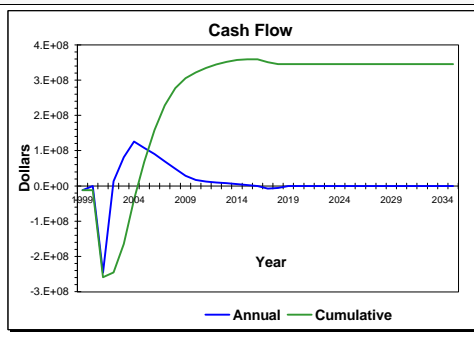

Project: **Liberty**
 Planning Area: **Beaufort Sea**
 Company: **BPX-Alaska**

Case (Alternative): **Tern Island**
 Analyst: **Jim Craig**
 Date of Analysis: **29-Nov-00**

Economic Parameters

Base Year: **2000** Inflation Rate Suggested Distribution to be used
 1.70% 2.30% 2.90% **2.30%**
 Geologic Probability (1- Risk): **100%** Real, After-Tax Discount Rate: 8.70% 12.70% 15.70% **12.70%**
 Max. gas price as a % of oil price: 100.00%

BOE Conversion Factor (Mcf/bbl): **5.62** Mcf/bbl

Oil Price:		Suggested Distribution			to be used
Landed Starting Price (\$/bbl):		\$11.51	\$15.78	\$20.31	\$16.00
Real	Period 1 Rate	3.30%	3.40%	4.10%	0.00%
Price	Period 2 Rate	0.00%	1.80%	2.10%	0.00%
Growth	Period 3 Rate	0.00%	0.70%	0.80%	0.00%
	Period 1 Begin Year				2000
	Period 2 Begin Year				2005
	Period 3 Begin Year				2011

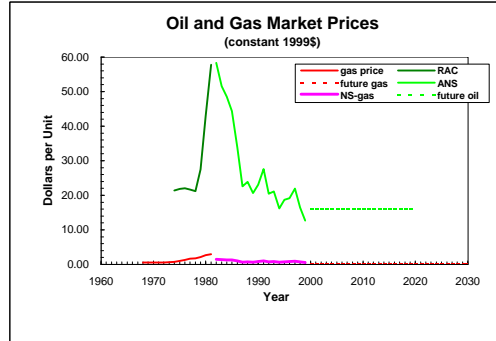

Gas Price:		Suggested Distribution			to be used
Wellhead Starting Price (\$/Mcf):		\$0.53	\$0.72	\$0.93	\$0.00
Real	Period 1 Rate	3.30%	3.40%	4.10%	0.00%
Price	Period 2 Rate	0.00%	1.80%	2.10%	0.00%
Growth	Period 3 Rate	0.00%	0.70%	0.80%	0.00%
	Period 1 Begin Year				2000
	Period 2 Begin Year				2005
	Period 3 Begin Year				2011

Tax and Royalty Inputs

Tangible Portion of Costs: with IDC w/o IDC ACRS Schedule: Federal Tax Rate: **35.00%**
 Lease (bonus bid): **0%** 0% Year 1: 14.29% State Tax Rate: **0.00%**
 Delineation/Appraisal (wells & seismic): **0%** 0% Year 2: 24.49% Property Tax Rate: 2.00% (use AdValorem sheet)
 Exploration well converted to producer: **51%** 30% Year 3: 17.49% Royalty Rate: **12.50%**
 Development Well: **51%** 30% Year 4: 12.49%
 ERD Well: **51%** 30% Year 5: 8.93%
 Platform & Production Equipment: **72%** 60% Year 6: 8.92%
 New Shorebase: **83%** 75% Year 7: 8.93%
 Pipeline: **100%** 100% Year 8: 4.46%
 Abandonment: **0%** 0%

Infrastructure Costs

Sunk Costs (\$MM): Lease: **\$11.80** Appraisal: **\$7.10**
Well Costs (\$MM/well): Exploration (Productive): **\$6.60** Development: **\$4.12** ERD well: **\$12.05**
Shorebase (\$MM): **\$0.00**
Platform Cost (\$MM): (Island + Production Facility)
 depth minimum most likely maximum to be used
 0 - 6 ft \$150 \$250.00 \$300.00 **\$206.50**
 7 - 25 ft \$200 \$270.00 \$340.00 **\$211.20**
 26 - 50 ft \$225 \$300.00 \$375.00 **\$270.00**
Pipeline Cost (\$MM): Unit cost (\$MM/mi): **\$6.53** Miles: 8.5 (enter in Schedule)
As-Spent Costs (\$MM): Shorebase: \$0 Platform: \$221 Pipeline: \$58 Drilling: \$99 Abandonment: \$19
Total Development Cost: As-spent (\$/bbl): **\$3.47** Constant (\$/bbl): **\$3.08**

Production Scenario

Operating Costs: Variable (per-unit): Oil: **\$0.30** \$/bbl Gas: **\$0.00** \$/Mcf Fixed (facility): (per-well basis) **\$0.60** \$MM/well/yr
Total Operating Cost: As-spent: **\$2.50** (\$/bbl) Constant: **\$1.97** (\$/bbl)
Transportation Costs: Oil: **\$5.71** \$/bbl Gas: **\$0.00** \$/Mcf Oil feeder pipelines: **\$1.25** \$/bbl TAPS tariff: **\$2.88** \$/bbl Tanker tariff: **\$1.58** \$/bbl Gas feeder pipeline: 0 Handling costs: 0
Field Life: **16** years
Abandonment (\$MM): **\$12.60**
National Stockpile: Imported oil expected to be embargoed (**45.40%**) Percent of year embargo lasts: **83.33%** NPV Stockpile Reserve Value (\$MM): **\$40.14**

Notes

Enter data in cells with blue fonts.
 Cells with black fonts contain calculations or guidelines.

- (1) Costs and prices are input in 2000\$ (blue) and inflated to the year as-spent (black). End-of-year accounting is used.
- (2) Expenses prior to the Base Year (Sunk costs) are inflated to constant Base Year dollars.
- (3) Development cost categories include all expenses associated with activity: management, engineering, studies, materials, installation, logistics.
- (4) Operating costs include all expenses associated with transportation, communication, maintenance, repair, project management, inspections, well workovers, supplies
- (5) Property tax should be included for all project infrastructure located on State lands (use Ad Valorem sheet).

Summary of Results

	Unrisked	Risked
Estimated Resources:		
Oil (MMbbl):	120.00	120.00
Gas (Bcf):	78.35	78.35
Estimated Values (MM\$):		
Net Income (BFIT):	\$696.64	\$696.64
Income to F&S governments:	\$366.37	\$366.37
Taxes:	\$189.75	\$189.75
Royalties:	\$176.61	\$176.61
Net Present Value (MM\$):		
NPV of Net Income (BFIT):	\$143.17	\$143.17
NPV Income to F&S governments:	\$106.94	\$106.94
NPV of Taxes:	\$49.43	\$49.43
NPV of Royalties:	\$57.51	\$57.51
NPV of Cash Flow:	\$40.41	\$40.41

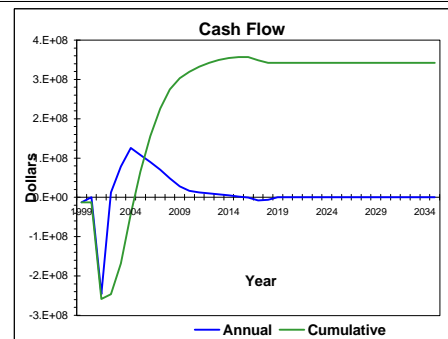

INPUTS

RESULTS

INPUTS

Project: Liberty	Case (Alternative): Bottomfast Ice Zone
Planning Area: Beaufort Sea	Analyst: Jim Craig
Company: BPX-Alaska	Date of Analysis: 29-Nov-00

Economic Parameters		Suggested Distribution			to be used
Base Year:	2000	1.70%	2.30%	2.90%	2.30%
Geologic Probability (1- Risk):	100%				15.70%
BOE Conversion Factor (Mcf/bbl):	5.62 Mcf/bbl				100.00%

Oil Price:		Suggested Distribution			to be used
Landed Starting Price (\$/bbl):		\$11.51	\$15.78	\$20.31	\$16.00
Real	Period 1 Rate	3.30%	3.40%	4.10%	0.00%
Price	Period 2 Rate	0.00%	1.80%	2.10%	0.00%
Growth	Period 3 Rate	0.00%	0.70%	0.80%	0.00%
	Period 1 Begin Year				2000
	Period 2 Begin Year				2005
	Period 3 Begin Year				2011

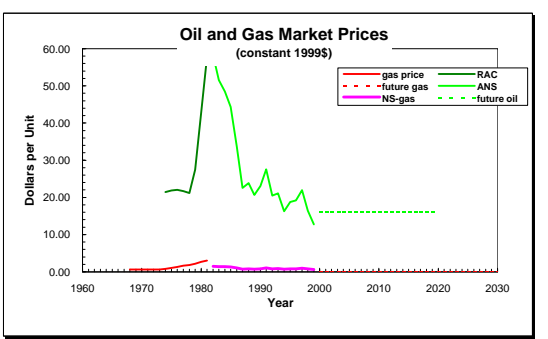

Tax and Royalty Inputs			
Tangible Portion of Costs:	with IDC	w/o IDC	
Lease (bonus bid):	0%	0%	
Delineation/Appraisal (wells & seismic):	0%	0%	
Exploration well converted to producer:	51%	30%	
Development Well:	51%	30%	
ERD Well:	51%	30%	
Platform & Production Equipment:	72%	60%	
New Shorebase:	83%	75%	
Pipeline:	100%	100%	
Abandonment:	0%	0%	

ACRS Schedule:	
Year 1:	14.29%
Year 2:	24.49%
Year 3:	17.49%
Year 4:	12.49%
Year 5:	8.93%
Year 6:	8.92%
Year 7:	8.93%
Year 8:	4.46%

Federal Tax Rate:	35.00%
State Tax Rate:	3.00%
Property Tax Rate:	2.00% (use AdValorem sheet)
Royalty Rate:	12.50%

Infrastructure Costs			
Sunk Costs (\$MM):		Platform Cost (\$MM): (Island + Production Facility)	
Lease:	\$11.80	depth	minimum
Appraisal:	\$17.10	0 - 6 ft	\$150
		7 - 25 ft	\$200
		26 - 50 ft	\$225
Well Costs (\$MM/well)		Pipeline Cost (\$MM):	
Exploration (Productive):	\$6.60	Unit cost (\$MM/mi):	\$3.40
Development:	\$4.22	Miles:	3.2 (enter in Schedule)
ERD well:	\$9.12		
Shorebase (\$MM):	\$0.00		

As-Spent Costs (\$MM):	
Shorebase:	\$0
Platform:	\$206
Pipeline:	\$11
Drilling:	\$225
Abandonment:	\$22
Total Development Cost :	
As-spent (\$/bbl):	\$4.10
Constant (\$/bbl):	\$3.51

Production Scenario			
Operating Costs:		Transportation Costs:	
Variable (per-unit):		Oil:	\$5.46 /bbl
Oil:	\$0.30 /bbl	Gas:	\$0.00 /Mcf
Gas:	\$0.00 /Mcf		
Fixed (facility):		Oil feeder pipelines:	\$1.00 /bbl
(per-well basis)	\$0.60 \$MM/well/yr	TAPS tariff:	\$2.88 /bbl
		Tanker tariff:	\$1.58 /bbl
Total Operating Cost:		Gas feeder pipeline:	0
As-spent:	\$2.35 (\$/bbl)	Handling costs:	0
Constant\$:	\$1.82 (\$/bbl)		

Field Life:	16 years
Abandonment (\$MM):	\$14.50
National Stockpile	
Imported oil expected to be embargoed (%):	45.40%
Percent of year embargo lasts:	83.33%
NPV Stockpile Reserve Value (\$MM):	\$35.67

Notes

Enter data in cells with blue fonts.
Cells with black fonts contain calculations or guidelines.

- (1) Costs and prices are input in 2000\$ (blue) and inflated to the year as-spent (black). End-of-year accounting is used.
- (2) Expenses prior to the Base Year (Sunk costs) are inflated to constant Base Year dollars.
- (3) Development cost categories include all expenses associated with activity: management, engineering, studies, materials, installation, logistics.
- (4) Operating costs include all expenses associated with transportation, communication, maintenance, repair, project management, inspections, well workovers, supplies
- (5) Property tax should be included for all project infrastructure located on State lands (use Ad Valorem sheet).

Summary of Results		
	Unrisked	Risky
Estimated Resources:		
Oil (MMbbl):	120.53	120.53
Gas (Bcf):	78.38	78.38
Estimated Values (MM\$):		
Net Income (BFIT):	\$718.70	\$718.70
Income to F&S governments:	\$415.71	\$415.71
Taxes:	\$228.70	\$228.70
Royalties:	\$187.01	\$187.01
Net Present Value (MM\$):		
NPV of Net Income (BFIT):	\$47.21	\$47.21
NPV Income to F&S governments:	\$68.96	\$68.96
NPV of Taxes:	\$27.67	\$27.67
NPV of Royalties:	\$41.28	\$41.28
NPV of Cash Flow:	(\$8.09)	(\$8.09)

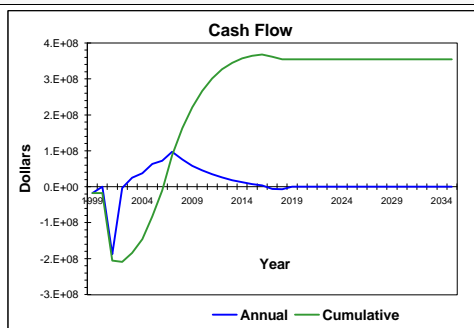

RESULTS

INPUTS

Project: Liberty	Case (Alternative): Onshore Location
Planning Area: Beaufort Sea	Analyst: Jim Craig
Company: BPX-Alaska	Date of Analysis: 29-Nov-00

Economic Parameters

Base Year: 2000	Inflation Rate	Suggested Distribution	to be used
Geologic Probability (1- Risk): 100%	Real, After-Tax Discount Rate:	1.70% 2.30% 2.90%	2.30%
BOE Conversion Factor (Mcf/bbl): 5.62 Mcf/bbl	Max. gas price as a % of oil price:	8.70% 12.70% 15.70%	15.70%
			100.00%

Oil Price:		Suggested Distribution			to be used
Landed Starting Price (\$/bbl):		\$11.51	\$15.78	\$20.31	\$16.00
Real Price	Period 1 Rate	3.30%	3.40%	4.10%	0.00%
	Period 2 Rate	0.00%	1.80%	2.10%	0.00%
	Period 3 Rate	0.00%	0.70%	0.80%	0.00%
Growth	Period 1 Begin Year				2000
	Period 2 Begin Year				2005
	Period 3 Begin Year				2011

Gas Price:		Suggested Distribution			to be used
Wellhead Starting Price (\$/Mcf):		\$0.53	\$0.72	\$0.93	\$0.00
Real Price	Period 1 Rate	3.30%	3.40%	4.10%	0.00%
	Period 2 Rate	0.00%	1.80%	2.10%	0.00%
	Period 3 Rate	0.00%	0.70%	0.80%	0.00%
Growth	Period 1 Begin Year				2000
	Period 2 Begin Year				2005
	Period 3 Begin Year				2011

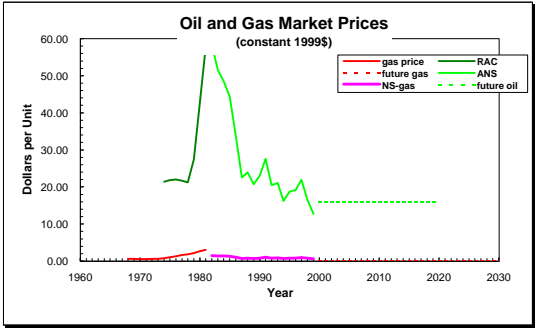

Tax and Royalty Inputs

Tangible Portion of Costs:	with IDC	w/o IDC	ACRS Schedule:	Federal Tax Rate: 35.00%
Lease (bonus bid):	0%	0%	Year 1: 14.29%	State Tax Rate: 3.00%
Delineation/Appraisal (wells & seismic):	0%	0%	Year 2: 24.49%	Property Tax Rate: 2.00% (use AdValorem sheet)
Exploration well converted to producer:	51%	30%	Year 3: 17.49%	Royalty Rate: 12.50%
Development Well:	51%	30%	Year 4: 12.49%	
ERD Well:	51%	30%	Year 5: 8.93%	
Platform & Production Equipment:	72%	60%	Year 6: 8.92%	
New Shorebase:	83%	75%	Year 7: 8.93%	
Pipeline:	100%	100%	Year 8: 4.46%	
Abandonment:	0%	0%		

Infrastructure Costs

Sunk Costs (\$MM):	Platform Cost (\$MM): (Island + Production Facility)	As-Spent Costs (\$MM):
Lease: \$11.80	depth minimum most likely maximum to be used	Shorebase: \$0
Appraisal: \$17.10	0 - 6 ft \$150 \$250.00 \$300.00 \$206.50	Platform: \$216
Well Costs (\$MM/well)	7 - 25 ft \$200 \$270.00 \$340.00 \$211.20	Pipeline: \$9
Exploration (Productive): \$6.60	26 - 50 ft \$225 \$300.00 \$375.00 \$270.00	Drilling: \$283
Development: \$4.22	Pipeline Cost (\$MM):	Abandonment: \$25
ERD well: \$11.22	Unit cost (\$MM/mi): \$2.80	Total Development Cost:
Shorebase (\$MM): \$0.00	Miles: 3.2 (enter in Schedule)	As-spent (\$/bbl): \$4.67
		Constant (\$/bbl): \$3.97

Production Scenario

Operating Costs:	Transportation Costs:	Field Life: 16 years
Variable (per-unit):	Oil: \$5.71 /bbl	Abandonment (\$MM): \$16.00
Oil: \$0.30 /bbl	Gas: \$0.00 /Mcf	National Stockpile
Gas: \$0.00 /Mcf	Oil feeder pipelines: \$1.25 /bbl	Imported oil expected to be embargoed (%): 45.40%
Fixed (facility):	TAPS tariff: \$2.88 /bbl	Percent of year embargo lasts: 83.33%
(per-well basis) \$0.60 \$MM/well/yr	Tanker tariff: \$1.58 /bbl	NPV Stockpile Reserve Value (\$MM): \$32.00
Total Operating Cost:	Gas feeder pipeline: 0	
As-spent: \$2.42 (\$/bbl)	Handling costs: 0	
Constant: \$1.84 (\$/bbl)		

Notes

Enter data in cells with blue fonts.
Cells with black fonts contain calculations or guidelines.

- (1) Costs and prices are input in 2000\$ (blue) and inflated to the year as-spent (black). End-of-year accounting is used.
- (2) Expenses prior to the Base Year (Sunk costs) are inflated to constant Base Year dollars.
- (3) Development cost categories include all expenses associated with activity: management, engineering, studies, materials, installation, logistics.
- (4) Operating costs include all expenses associated with transportation, communication, maintenance, repair, project management, inspections, well workovers, supplies
- (5) Property tax should be included for all project infrastructure located on State lands (use Ad Valorem sheet).

Summary of Results

	Unrisked	Risked
Estimated Resources:		
Oil (MMbbl):	120.41	120.41
Gas (Bcf):	78.10	78.10
Estimated Values (MMS):		
Net Income (BFIT):	\$632.46	\$632.46
Income to F&S governments:	\$386.90	\$386.90
Taxes:	\$201.15	\$201.15
Royalties:	\$185.75	\$185.75
Net Present Value (MMS):		
NPV of Net Income (BFIT):	(\$2.11)	(\$2.11)
NPV Income to F&S governments:	\$49.03	\$49.03
NPV of Taxes:	\$12.91	\$12.91
NPV of Royalties:	\$36.12	\$36.12
NPV of Cash Flow:	(\$36.44)	(\$36.44)

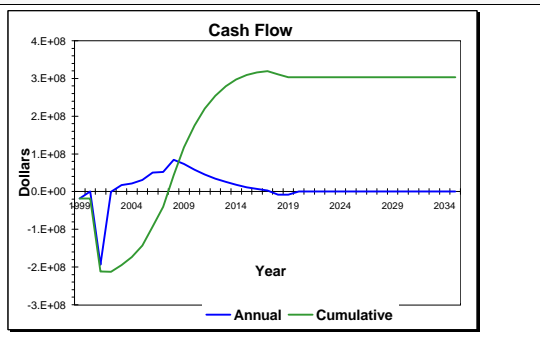

RESULTS

An Engineering Assessment of Double-Wall Versus Single-Wall Designs for Offshore Pipelines in an Arctic Environment (C-Core, 2000)

This appendix was published as part of the Liberty Development and Production Plan (DPP) Draft Environmental Impact Statement (EIS) and was not revised for the Final EIS. The reader is referred to this appendix in the Draft EIS. This appendix is also available on the CD-ROM (MMS 2002-019 CD) and on the Internet (<http://www.mms.gov/alaska/cproject/liberty>).

An Engineering Assessment of Double Wall Versus Single Wall Designs for Offshore Pipelines in an Arctic Environment

Final Report

Prepared for:

Minerals Management Service, US Dept. of Interior

Prepared by:

C-CORE
Colt Engineering Corporation
Tri Ocean Engineering Ltd., &
AGRA Earth & Environmental

C-CORE publication

00-C4-Final (April, 2000)



C-CORE
*Memorial University of
Newfoundland Bartlett Building
St. John's, NF
Canada A1B 3X5*

T: (709) 737-8354
F: (709) 737-4706

Info@ccore.ca
www.c-core.ca

The contents of this report are the exclusive opinion of C-CORE, Colt Engineering, Tri Ocean Engineering, and AGRA Earth & Environmental Inc. The results and opinions expressed in this report do not necessarily reflect any regulatory position held by the Minerals Management Service.

3. EXECUTIVE SUMMARY

3.1 Background

The principal rationale for conducting this study is: “to assess if a double walled design provides the same or a greater degree of engineering integrity and environmental robustness as compared to a thicker walled single pipe design for an arctic offshore application and to appraise the economics of one selection over the other relative to the potential risks (real and/or perceived) associated with either application”.

The objective of the study as stated in the contract authorizing the work is: “to conduct an extensive, non bias engineering and environmental assessment, considering both pro’s and con’s, of single versus double walled designs for offshore pipelines in an arctic environment”. It responds to a number of issues raised by stakeholders in relation to proposed offshore pipelines in Alaskan arctic.

The study team was provided with the issues that had been documented and they set out a program that was designed to address advantages and disadvantages.

A great deal of information was provided to the study team. Extensive background information was gathered from the July 28, 1999 kick off meeting from the stakeholders who attended. Of particular value was a workshop sponsored by the Minerals Management Services in Anchorage on November 8 and 9, 1999. The presentations covered a wide spectrum of design, construction and monitoring experience for offshore pipelines. The discussions were extensive and incisive. The team was also provided with selected documents from the proposed Northstar Pipeline and Liberty Pipeline projects. The study included an extensive review of the literature and a survey of offshore pipeline operators. Double wall pipe usage in the petroleum, petrochemical and chemical industry was identified to document current applications. Several offshore double wall pipe systems were identified, some of which have been in existence for over 20 years.

No existing offshore double wall pipe systems have been constructed to provide secondary containment in the event of a failure of the product line. Most were configured to provide insulation for the inner pipe. The Colville River crossing of the Alpine pipeline is the only pipeline known to have been designed to provide product containment in the event of a leak.

At the time the literature and operator survey was carried out, there were no known failures of offshore double wall pipes during operation. As the original draft of the report was being completed the study team became aware of a failure of a double wall pipeline in the Erskine field of North Sea. The cause of the failure is unknown but both the inner and outer pipes failed. Considering the total miles and length of service of existing double wall pipelines, this failure would indicate an annual probability of containment failure of 2×10^{-3} , which is comparable to offshore pipeline failure statistics presented at the Alaskan workshop.

3.2 Project Basis

A project design basis was formed in consultation with MMS for general conditions for offshore pipelines near Prudhoe Bay. The study parameters are documented in the report in Table 7.1-1. The detailed results of this study are sensitive to some of the parameters selected. The general conclusions presented are valid for the project basis and study assumptions considered (sections 7.1.1 and 7.6.1.5). The conclusions may change with changes to the project basis or assumptions.

For the base case, study Case A, the single walled pipeline was considered to be a grade X52 12.75" outside diameter (O.D.) pipe with a 0.500" wall thickness. The double walled system comprised two grade X52 pipes both with a 0.375" wall thickness. The inner pipe was 12.75" O.D. and the outer pipe was 14.00" O.D. Three alternative double wall pipe systems, designated Cases B, C & D, were studied and compared to Case A. Cases B and C considered fixed solid bulkheads and shear rings respectively. Case D is simply one pipe within another with approximately 0.5" clearance between the two outer pipes (section 7.7).

Only the outermost wall of all four pipeline study case configurations was considered to require a coating, as the annulus of double wall configurations is a potentially low corrosive environment (section 7.1).

Double walled systems have been adopted elsewhere for both onshore and offshore industrial applications for thermal insulation, leak containment and protection of flowlines (section 6.1). The project basis assumed the primary reason to use a double wall system, rather than a single wall pipeline, buried offshore in an arctic environment is leak containment.

3.3 Assumptions

A number of assumptions were necessary during the course of the study. The most important of these relate to 'functional failure' and 'containment failure'. A functional failure is defined as pipeline system damage without loss of product containment integrity to the environment. A containment failure is defined as pipeline system damage with loss of product containment integrity, that is product loss to the external environment. Hence a breach of either the inner or outer wall of a double wall pipe is considered as a functional failure, provided the other pipe retains its integrity or containment. Loss of containment through only one of the two pipes comprising the double wall system is not considered to be a containment failure of the system.

It is assumed that construction will take place during the winter season working from an ice-strengthened surface and that work will be completed within one season (sections 7.7 and 9.3).

It is assumed that the tensile strain capacity in the vicinity of the pipeline girth welds is about an order of magnitude lower than that of the parent pipe. The lower capacity in the weld vicinity dictates the tensile strain limit for the pipeline. Recent advances in welding and inspection techniques may increase this lower capacity under certain conditions towards that of the parent pipe material. This potential increase in tensile strain capacity is ignored in this study. Instead, for the double wall pipeline system, the girth welds on the inner and outer pipes are considered to be significantly offset (staggered) by several meters along the length of the system. The tensile strain limit of at least one pipe in any double wall cross section is then controlled by that of the parent pipe rather than the girth weld. This staggering of the welds is considered to be of benefit in maximising the structural integrity of the double wall system under flexure.

3.4 Design and Construction

The design and construction of a double wall pipe is more complex than a single wall pipe because of the additional pipe, associated welds and tie in procedures. There are numerous design, operating and monitoring difficulties associated with spacers and bulkheads or shear rings. There is no compelling reason to use them when the primary function of the outer pipe is secondary containment.

The study team selected Case D for the base case since it was the simplest, yet most viable alternative. This double wall system was subjected to detailed analysis of costs and risks, and was deemed to be viable for arctic conditions. The pipeline design process for an actual project may indicate that a robust single wall pipeline is the preferred solution over a double wall pipeline system due to specific project considerations.

The double wall pipe system may be assembled by pulling outer pipe lengths over the inner pipe lengths (section 7.7).

If the tensile strain limits of both systems are exceeded the single wall pipe could lose containment before both walls of the double wall pipe would lose containment provided the girth welds of the inner and outer pipes were staggered. Following section 7.6.1 and the tensile strain assumptions presented in section 3.3, the probability of a significant defect existing in both the inner and outer pipelines of the double wall system within a region of peak tensile strain is very remote. Considering these factors, the study team has concluded the probability of simultaneous failure of both walls of double wall pipe is lower than a containment failure of a single wall pipeline.

The strains induced in both pipeline systems during installation from the ice surface are considered to be less than those imposed under extreme environmental loads, such as an ice scour event.

The single wall pipe is simpler to construct than the double wall pipe (section 7.7). The double wall pipe has twice the number of girth welds as a single wall pipe. Construction requires inserting one pipe within the other with associated outer pipe tie-in welds, pressure testing, drying and charging the annulus following construction. The welds of the outer pipe can be inspected with the same techniques used for a single wall pipe except for the tie-ins (section 7.8). The tie-ins can be inspected by ultrasonic testing.

The double wall pipe restrains the monitoring of the outer pipe (section 9.5). It can be checked routinely for total integrity using a pressure based annulus leak detection system. This system can provide continuous integrity monitoring of both inner and outer pipes on a pass/fail basis only. The annulus also provides space for an external leak detection system, such as hydrocarbon sensing tape or a local corrosion monitoring system (section 7.9). Conventional pigging during operations with present day technology cannot reliably inspect the outer pipe of a double wall system, but pigging is equally reliable for the inner pipe as for a single wall system.

Interior corrosion rates of both product (inner) pipelines are similar as they are carrying the same product (section 7.6.2). External corrosion of the product (inner) pipe would be less in a double wall pipe since the annulus should provide a potentially low corrosive environment (section 7.6.2). The exterior wall of the outer pipe will operate at a slightly lower temperature than a single wall pipe and thus may have a slightly lower rate of corrosion. Corrosion failure of both the inner and outer pipes in a double wall pipeline would be required for loss of containment to occur.

Abrasion between the inner and outer pipes is not considered to be significant given the expected operating conditions of the system when no significant repetitive fluctuations in product pressure or temperature occur.

3.5 Operations and Maintenance

It is the opinion of the study team that double wall pipeline configurations offer moderate-to-significant operating and maintenance advantages relative to single wall pipelines because of the ability for secondary containment of oil in the event of an inner pipe failure (section 7.9).

The main operating and maintenance disadvantages of a double wall pipeline relative to single wall pipelines are the limited capability to inspect and monitor the condition of the outer pipe.

Double wall and single wall pipeline configurations have similar operating and maintenance requirements on the product (inner) pipe for operational condition monitoring, leak detection, chemical inhibition application, pipe cleaning, defect monitoring and evaluation, and cathodic protection testing, monitoring and maintenance (section 7.9).

3.6 Repairs

A double wall pipe would be more complex to repair than a single wall pipe but the greatest component of repair costs would be similar for both systems. A double wall section could be prepared during construction and stored for use in the unlikely event of a failure. The difference in repair costs in the case for a functional failure would be proportional to the difference in initial materials and fabrication costs. Similarly, repair costs of a double wall pipe for a total containment failure (failure of inner and outer pipes) would be greater than a single wall pipe by about the same proportion (about 25% higher).

3.7 Costs

The comparison of design, material and fabrication costs indicates the double wall pipe to be 1.27 \pm 25% times greater than a single wall pipe. Other costs such as the civil works costs comprising excavation, backfill and ice road during construction and abandonment are estimated to be the same for both alternatives. The operations and maintenance costs are estimate to be similar to the double wall pipe costs are estimated to be only 3.5% higher at present value over life relative to single wall pipeline configuration (section 8.5).

The greatest components of life cycle costs are civil works costs and operations and maintenance costs. They are similar for both alternatives. The upfront costs for a double wall pipe are greater but are less significant in life cycle costs at present value because of the dominance of the other cost factors, such as civil works and operations & maintenance costs.

If a containment failure occurs in both pipes of the double wall pipeline, the product loss would be the same as a containment failure of a single wall pipe of comparable robustness. Any leak to the external environment associated with a single wall (or double wall) pipe will require cleanup. The cost could be very high, depending on the length of time it goes undetected and the amount of product released to the environment. The potential cost of cleanup is not included in life cycle costs as the probability is so low and the cost so variable that it would distort life cycle costs.

3.8 Risk

No failure statistics exist on the probability of failure for arctic offshore pipelines, but experts have produced statistics for other offshore pipelines, relating these to different hazards such as internal corrosion, external corrosion, external loading and so on. Although the statistics differ somewhat in hazard source characterization and distribution, the data proved to be valuable in establishing a risk framework for arctic pipelines, taking into account the different environmental factors. This framework was used to evaluate the probability of failure of a double wall pipe and a single wall pipe.

The existing statistics cover a range of design standards, construction quality, inspection and operation & maintenance. They include failure statistics for pipelines constructed, operated and maintained to standards that would not be accepted for arctic offshore pipelines today. Such arctic pipelines are expected to have a probability of failure an order of magnitude lower than older pipelines.

The analysis of hazard frequency estimates for buried arctic offshore oil pipeline systems was framed with respect to the project basis. The hazard frequency estimates were representative probabilities based on the historical record of offshore pipeline system failures for single wall pipelines located outside an arctic environment in the Gulf of Mexico. The historical records were subjectively reinterpreted for consideration of the hazards and associated causal events appropriate to a buried offshore arctic pipeline to estimate the hazard frequencies (section 10.3.2). Increased arctic pipeline experience and a more comprehensive quantitative risk assessment, that includes risk uncertainty, may present a basis for redefining the currently proposed hazard recurrence rates.

For the study parameters investigated and the underlying assumptions considered to develop the inferred hazard statistics, the double wall alternative has a lower risk of containment failure (i.e. loss of product) compared with the single wall pipeline. This is primarily due to the combined probabilities associated with simultaneous girth weld failure of both the inner and outer pipelines, as well as combined corrosion failure of the double wall system. Conversely, the double wall pipeline system has an increased risk of functional failure, primarily related to serviceability. The failure probabilities for both pipeline systems, however, meet or exceed the current practice for the target safety levels recommended by DnV (1996).

From the perspective of environmental damage, the primary concern is the risk of containment failure and product loss. Although the annual system failure probability of the double wall pipeline system (6×10^{-4} system failures/year) is marginally lower than the conventional single wall pipeline (1×10^{-3} system failures/year), this cannot be considered in isolation or as a generalized conclusion for double wall pipeline systems. The comparative assessment must also be viewed in terms of the defined parameters and constraints of the overall risk analysis framework. The costs associated with reduction of the potential hazard frequency would typically be only a fraction of the costs of responding to a containment failure. In general terms, pipeline expenditure is best directed to reduction in hazard frequency rates (i.e. probability of an event occurrence) as opposed to mitigation of event consequence (i.e. severity of the event). Any one or a combination of engineering design considerations can reduce the probability of an event occurrence. Either a single wall pipeline or double wall pipeline can be designed to satisfy a target safety level. Optimization of the design requires consideration of several factors, including potential environmental loads, properties of the seabed, properties of the product, geotechnical conditions, transmission temperature and costs. For example, increasing the depth of burial can reduce the probability of an event due to ice scour.

Tensile strain limits are typically based on crack-tip opening displacement tests during the welding procedure qualification and control development. The tensile strain limit is defined by a complex relationship between material toughness, flaw acceptance criteria (size, shape and position) and tensile strain limits. The engineered critical assessment (ECA) determines the tensile strain limit. To establish a greater pipeline resistance to weld failure, the weld toughness needs to increase (considering the pipeline, heat-affected zone and weldment) and/or the maximum acceptable flaw size needs to decrease. Increasing toughness is generally synonymous with a lower pipeline grade and thus a greater wall thickness would be required in order to satisfy the specified strain limits. Decreasing the acceptable flaw size tends to increase pipeline construction costs by raising the welding and weld quality control standards.

Statistics for pipeline failures (Bea 1999, Farmer 1999) indicate corrosion to be the greatest single factor that accounts for pipeline failures. However, they reflect a spectrum of pipelines over a span of time where design protocols, construction technique and inspection procedures have not been of the same standard as applied today. One or more of several methods can be applied to mitigate corrosion so that with modern pipelines, it will very likely not dominate failure statistics.

If a given target safety level for containment failure is accepted, for example an annual failure probability of 10^{-4} , it can be met by proper engineering design that takes into account all significant factors including constructability and cost. For certain conditions a robust single wall pipe may be preferable to a double wall pipe. Alternatively, the probability of a containment failure may best be reduced to the target level by the proper design of a double wall pipe. For this study, a generic arctic offshore regime has been assumed. It is not linked to any specific project. Each pipeline must be designed for the specific potential loads, seabed conditions, product properties, environmental considerations, constructability and life cycle costs.

There are peripheral issues, related to the level of inspection, detection, integrity monitoring and maintenance of the outer wall pipeline as well as the associated risk uncertainty. These factors must be considered with respect to the objectives of the pipeline operators, regulatory authorities and the adopted risk evaluation/risk management procedures throughout the life cycle.

3.9 Advantages and Disadvantages

Selection of the most appropriate pipeline, whether it be single wall or double wall, will be influenced by several factors. There is no basis for a simple conclusion that one is better than the other as each has advantages and disadvantages. The only basis would be a project specific risk assessment that concluded that the risk of oil getting into the environment was lower for double wall pipe. Both robust single wall pipe and double wall pipe meet or exceed specified code requirements; for example DNV (1996).

The most compelling reason for a double wall pipe, instead of a robust single wall pipeline, is the containment of a product leak. The annulus can also be monitored for evidence of a leak (or even pipe degradation). In these respects it has advantages over a single wall pipe. However, a leak in a robust single wall pipe has a very low probability. The thicker wall than normally used provides greater strength to resist environmental loads and greater resistance to erosion and corrosion than is the case for most of the offshore pipes (if not all) that have experienced leaks or failures. The major advantages of a single wall pipe are simpler construction, lower construction costs, lower life cycle costs and greater inspection reliability. The major disadvantage is that any size of leak will release product into the environment. The major advantage of the double wall pipe is that the probability of a failure or leak in both pipes at the same time is very low. It has a lower risk of product release to the environment than a single wall pipe. The disadvantages of the double wall pipe include its relative complexity and potential difficulties with integrity monitoring of the outer pipe.

Assessment of Extended-Reach Drilling Technology to Develop the Liberty Reservoir from Alternative Surface Locations (MMS, 2000)

This appendix was published as part of the Liberty Development and Production Plan (DPP) Draft Environmental Impact Statement (EIS) and was not revised for the Final EIS. The reader is referred to this appendix in the Draft EIS. This appendix is also available on the CD-ROM (MMS 2002-019 CD) and on the Internet (<http://www.mms.gov/alaska/cproject/liberty>).

Appendix D-3

Assessment Of Extended Reach Drilling Technology To Develop The Liberty Reservoir From Alternative Surface Locations

Kyle Monkeliën, Minerals Management Service, Alaska, February 24, 2000

A. INTRODUCTION

This paper reviews extended-reach drilling experience and technology. It also reviews whether the use of this technology from alternative surface locations can be considered technically reasonable to meet the objectives of BPXA's proposed Liberty development project. Three alternative surface locations have been identified: (1) offshore, south of the proposed island location; (2) bottomfast-ice location; and (3) an onshore location (Fig. D-3-1).

The Liberty reservoir is located approximately 5 miles offshore in Foggy Island Bay. BPXA proposes to develop the reservoir using production and drilling facilities located on a manmade gravel island centrally located over the reservoir (Fig. D-3-1). The proposed location (Alternative I) was chosen by BPXA as its preferred site, because it provided the most economical location to develop the prospect using standard technology.

During a Minerals Management Service (MMS) workshop on arctic pipelines, one speaker stated that extended-reach drilling efforts with horizontal displacements of up to 10 kilometers (6.22 miles) are possible. "Distances may be limited to about 10 kilometers...may require intermediate traction devices not yet developed" (USDOI, MMS, and C-Core, 2000:Attachment D, 2. Construction (2)). The professional literature also supports the potential for extended-reach drilling to achieve greater distances than have been achieved to date. The MMS has taken into consideration these projected extended-reach drilling capabilities and existing experience and reasonable assumptions relative to developing the Liberty reservoir.

B. NORTHSTAR FINAL EIS CONCLUSIONS

The Northstar Final EIS concluded that the maximum extended-reach drilling for the purpose of analyzing alternative drill sites was a horizontal displacement of approximately 4 miles (U.S. Army Corps of Engineers, 1999:Fig. 3-6, footnote 1). This was based on extended-reach drilling experiences, predominantly Wytch Farm in the United Kingdom, with a 4.23-mile horizontal offset, and Niakuk in Alaska, with a 3.5-mile horizontal offset. The Northstar Final EIS further concluded that reservoir geology and depth also might limit the well "reach" to distances much less than 4 miles in some areas. Since publication of the Northstar Final EIS, an extended-reach drilling well with a horizontal displacement of 6.67 miles has been drilled at Wytch Farm. This well and its implications will be discussed in more detail later in the report.

C. EXTENDED-REACH EXPERIENCE

1. Drilling

Figure D-3-2 "Comparison of Existing Extended Reach Technology to Proposed Liberty Development Wells" shows a plot of current-record extended-reach drilling wells by true vertical depth and horizontal departure (modified from O'Hare and Hart's E&P, 1999). Typically, extended-reach drilling wells are considered to be those wells that have a horizontal reach to a true vertical depth ratio greater than 1:5. That document further defines an envelope

between standard technology and advanced technology. The envelope reflects a break between clusters of wells within the same depth/horizontal offset range that use standard technology to achieve total depth and individual wells that surpass these clusters and require advanced technology to drill. The MMS considers this a reasonable basis to begin assessing extended-reach drilling capabilities for use in developing the Liberty prospect.

Figure D-3-2 also shows several world-record extended-reach drilling wells that have been drilled to date by multiple companies. The current world record for a horizontal departure is the Wytch Farm M-16 well; drilled with a horizontal departure of over 35,000 feet (6.67 miles). This was the fifteenth well in a series of progressively longer offset wells in the stage III development of the Sherwood reservoir. Based on the Wytch Farm success, BPXA has suggested that step outs (horizontal departures) of 15 kilometers (9.3 miles) should not be dismissed as a possibility in the future (Hart's E&P, 1999).

The Wytch Farm field has been under development since the early 1990's. The stage I and II developments of the Sherwood reservoir were first drilled and developed in the mid-1970's from onshore locations. The initial development program used existing technology; "standard wells drilled from onshore drill sites" (Oil and Gas Journal, 1998). Subsequent development of the offshore portion of the reservoir employed extended-reach drilling methods from onshore facilities. BPXA originally anticipated that horizontal departure wells of 10,000 feet were possible with the technology that existed in 1992. BPXA was successful with the first wells and has built on the knowledge gained from those wells to increase the reach of extended-reach drilling at Wytch Farm to the current record.

British Petroleum also successfully has used extended-reach drilling for development wells for the Niakuk and Milne Point reservoirs on the North Slope. The current-record extended-reach drilling well on the North Slope is the Niakuk, NK-11A well, which was drilled with a horizontal displacement of 19,804 feet (3.75 miles) and measured depth of 23,885 feet (4.52 miles). Similar to Wytch Farm, the Niakuk reservoir was originally developed using conventional drilling practices (the first 14 wells) and designs (Hart's E&P, 1999). The Niakuk NK-11A well was the fifteenth well in a series of progressively longer offset wells.

Extended-reach drilling technology has not been used in the startup of any known developments. All current extended-reach drilling records have been achieved in existing, mature fields. These records have been set where an established drilling history and cumulative experience was built on conventional drilling programs. Experience is a significant component of any extended-reach drilling program. When considering the Wytch Farm project; "[S]uch long wells would not have been economical had it not been for some impressive drilling performance, which

has been continuously improved over the life of the project" (Hart's E&P, 1999). For the Wytch Farm M-11 well, the fourteenth extended-reach drilling well drilled into the reservoir; British Petroleum still took 1 year to plan the well (Oil and Gas Journal, 1998). Despite the experience of seven previous extended-reach drilling wells, both the Niakuk NK-11 and NK-41 wells experienced significant drilling problems that resulted in drilling suspensions, plug backs, sidetracks, and abandonment (Society of Petroleum Engineers, Inc., 1999). When developing extended-reach drilling projects, even in areas where multiple extended-reach drilling wells have been drilled, "as the rock environment changed, operators have had to start over" (Offshore, 1996).

2. Production

Little professional literature regarding extended-reach drilling experience exists, and even less information is available on the overall performance and lifecycle of extended-reach drilling wells during production. Currently producing extended-reach drilling development wells have been in production for only 5-7 years. While there is no literature regarding the use of extended-reach drilling wells for water or gas injection, at least one is proposed for the Wytch Farm field (Oil and Gas Journal, 1998). None of the Niakuk extended-reach drilling wells is an injection well. Due to the short production history and no information on extended-reach drilling injection wells, there is little or no information available on the long-term maintenance and serviceability of extended-reach drilling development wells.

Extended-reach drilling wells also can present problems for handling completions and conducting workover operations. The measured depths of most extended-reach drilling wells place them outside the reach of many of the conventional intervention tools (Hart's E&P, 1999). Intervention would require either the construction of a specially designed coiled tubing unit or maintaining the original drilling rig on sight for use as a service rig. Other intervention tools would need to be developed to perform workover or other downhole work (Reeves, 2000, pers. commun.). The cost benefits of future intervention versus well abandonment would need to be assessed on a well-by-well basis.

Discussion: Since publication of the Northstar Final EIS, an extended-reach drilling well with a 6.67 mile horizontal departure has been drilled at Wytch Farm. The MMS believes that there are several factors that make it inappropriate to extrapolate from the documented successes associated with extended reach drilling to justify the exclusive use of extended-reach drilling for developing the Liberty reservoir. We believe it is unreasonable to assume that an exclusive extended-reach drilling development project could achieve the same success rate and cost benefit ratio as a conventional drilling program specifically designed for the Liberty Project. This is based in part on (1)

the lack of an adequate drilling history for the project, which can be obtained only through drilling experience, and (2) on the lack of comparable extended-reach drilling experience on the North Slope. This knowledge is essential in developing an extended-reach drilling strategy for the Liberty Project area, if these alternative surface locations are considered. In each instance (where information is available), the development of record extended-reach drilling distances is predicated on initial geological information obtained from previous wells drilled into the reservoir and surrounding geology.

To date, no extended-reach drilling wells drilled on the North Slope would be equivalent to any well necessary to develop the Liberty reservoir from the onshore or bottomfast-ice zone. Because of this lack of site-specific well data, it is unrealistic to expect to accurately project the extended-reach drilling limits for the Liberty development.

For the purpose of comparison, the MMS will assume that the future of extended-reach drilling development for the North Slope can be extrapolated using a straight line that intersects with the departure distance of the Niakuk record well. The NK-11A well, which was drilled in a similar geological environment as that projected for the Liberty Project, provides a reasonable basis for this extrapolation. Because the Liberty reservoir is deeper than the Niakuk reservoir, the depth ratio for the Niakuk well has been extrapolated to intersect the potential Liberty well regime. Using this extrapolation, we find that the intersection of horizontal distance and the depth ratio line is 21,000 feet. To allow for near-term advances in the extended-reach drilling process, we assume a 10% increase in the horizontal distance and establish a 23,000-foot (4.36-mile) achievable offset at reservoir depth for the Liberty development. This equates to a depth ratio of approximately 2. We can use this number to determine the number of wells that can be drilled for Liberty, providing that geological and technical abilities remain similar. Figure D-3-2 shows that the onshore and bottomfast-ice locations fall outside the standard technology envelope, and that approximately half of the bottomfast-ice location wells are outside the depth-ratio 2.0 envelope. Figure D-3-2 also shows that the wells for the proposed Liberty Island location and for the southern island location are within the envelope of current standard technology as well as the envelope created by extrapolating the Niakuk experience.

Table D-3-1 shows the horizontal departures required to drill the same suite of wells to the bottom-hole locations proposed by BPXA for the surface locations for each of the proposed alternatives. Based on an estimated maximum 23,000-foot horizontal displacement, 2 of the 22 proposed development wells could be drilled from the onshore location, and only 11 could be drilled from the bottomfast-ice zone. All the wells could be drilled from the southern island location. Of the 11 wells that could be drilled from the bottom fast-ice zone, 7 are producing wells and 4 are water-injection wells; none of the gas-injection wells could

be drilled. This has significant implications for proper reservoir management. The Liberty reservoir will require a gas reinjection program to maintain reservoir pressure and provide for efficient production.

D. TECHNICAL CONSIDERATIONS FOR USING EXTENDED-REACH DRILLING

When planning extended-reach drilling wells, a combination of several factors needs to be considered. These include rig capacity and capability, well design, geological conditions, and production capabilities. Drill-rig capacity can limit the loads that can be handled safely when using longer drilling strings and casing lengths. A drilling rig's horsepower places limits on the ability to overcome increasingly higher torque and frictional forces encountered in high-angle wells. The drilling rig's mud-pumping capacity, both volume and pressure, limits the ability to circulate cuttings out from highly deviated wells, lubricate and cool the drill bit, and control well-bore pressures. Current drilling rigs on the North Slope have a maximum rated capacity of approximately 25,000 feet.

The well design must calculate for the target depth, increasing the departure angle, long lengths of uncased open bore hole, and managing the well-bore environment to allow casing and down-hole tools to move freely through the highly deviated extended-reach drilling well bore. Planning must be conducted to establish procedures necessary to reduce the potential for stuck pipe and maintain hole stability.

Geologic considerations include fault penetrations, unstable or reactive formations, and abnormal pressures. All of these factors become more as the horizontal and vertical offset of the bottom hole location increases. While the Niakuk drilling experience indicates that these factors are either not present or can be accommodated, the Niakuk experience also demonstrates that complications often occur and that a general applicability of a new "record well" is inappropriate.

1. Geological Considerations

Some of the geology of the Liberty reservoir is uncertain, including the extent of the gas cap for the reservoir and the location of the tar mat at the base of the reservoir. Both of these factors have significant implications to the well pattern and the total number of wells that would be required to efficiently produce the Liberty reservoir. Gathering information to evaluate the gas cap and the extent of the tar mat would require that extended-reach drilling wells, outside the envelope discussed earlier, be drilled early in the process. The higher risks and extended planning times associated with drilling these wells effectively would

increase the development cost as compared to a conventional drilling program.

Conservation of Resource: The MMS is responsible for ensuring that reservoirs are produced at rates that will provide for economic development and depletion of the hydrocarbon resources in a manner that would maximize the ultimate recovery of the resource (30 CFR 250.1101 (a)). BPXA has submitted a proposal that uses standard technology to develop Liberty and proposes to achieve this result. As stated previously, MMS has extrapolated a limit of 23,000 feet horizontal displacement as the maximum displacement for a new start development such as Liberty. Based on this limitation, we have determined that, of the 14 production wells needed to produce Liberty, only 7 would fall within this limit. In addition, none of the gas- and only four of the water-injection wells would fall within this limit. With this decrease in the number of wells, we do not consider it possible to maximize the recovery of the resource contained in the Liberty structure.

2. Other Considerations

The 22 wells proposed for the Liberty development project are directed at producing a primary reservoir. Additional potential reserves may exist in the reservoir in fault blocks to the north of the primary target. Additional accumulations of hydrocarbons are known to exist in a zone below the target formation, which also extends to the north and east of BPXA's proposed island location. BPXA's proposal provides for additional delineation and development of these other potential reserves as part of the Liberty development project. Development of these potential accumulations would require even greater extended-reach drilling horizontal displacements. Realistically, these potential reserves could be explored or produced from the alternative surface locations.

Conclusion: Based on current technology and the drilling and production history of current extended-reach drilling technology, MMS concludes that the maximum reasonable horizontal offset for analyzing alternative drilling locations to develop the Liberty reservoir is 23,000 feet or 4.36 miles. While all wells drilled from the southern island location would fall within this offset, none of the onshore wells, and only half of the bottom fast ice location production wells would.

One of MMS's primary responsibilities is to monitor production activities to ensure that oil and gas resources are developed in a responsible manner. Approval of a development plan that cannot demonstrate this directive would be irresponsible management of the Nation's resources.

The extended-reach drilling records have been set in mature development areas based on an accumulation of drilling experience and geologic knowledge. Extended-reach

drilling has not been used, or proposed, for a new startup development project. Additionally, extended-reach drilling wells are planned and approved as single-well projects, not as a comprehensive development program. Information on the long-term viability of extended-reach drilling wells for production is limited, and industry has little experience in the use of extended-reach drilling wells for gas- or water-injection wells.

Geologic knowledge of the area and an understanding of the potential drilling constraints that could be encountered must be acquired early in the development process. The extended-reach drilling projects have acquired the necessary drilling experience and geologic models through the drilling of conventional wells in the specific area. We do not have this advantage if either the onshore or bottom fast ice is chosen. As shown, each of the proposed locations would require that wells be drilled as extended-reach drilling wells beyond currently demonstrated capabilities.

REFERENCES CITED

- Hart's E & P. 1999. Extending the Limits, p. 66.
- O'Hare, J. and Hart's E & P. 1999. North Sea Platforms Revamped, p. 71.
- Oil and Gas Journal. 1998. BP Completes Record Extended-Reach Well. Oil and Gas Journal, January 19, 1998, p. 24.
- Offshore. 1996. Horizontal, Extended Reach Section tendencies Outlined. Offshore, May 1996, p. 27.
- Reeves, B. 2000. Personal communication in January 2000 from Bren Reeves, Drilling Engineer, Shared Services Drilling, to Jeff Walker, Regional Supervisor, Field Operations, USDO, MMS, Alaska OCS Region.
- Society of Petroleum Engineers, Inc. 1999. An Integrated Solution of Extended-Reach Problems in the Niakuk Field, Alaska: Part 1 Wellbore Stability Assessment, SPE 56563.
- U.S. Army Corps of Engineers. 1999. Beaufort Sea Oil and Gas Development/Northstar Project, Final EIS. Anchorage, AK: U. S. Army Corps of Engineers.
- USDO, MMS, and C-Core. 2000. Proceedings of the Alaska Arctic Pipeline Workshop, November 8-9, 1999. Attachment D, 2. Construction (2).

Table D-3-1 Comparison of True Vertical Depths to Horizontal Departure Distances for Selected Liberty Island Location

Well #	Type	TVD	Proposed	Southern Island	Bottomfast Ice	Onshore
1	Oil Producer	11,050	1,800	8,270	22,490	28,380
2	Gas Injector	10,600	9,500	15,510	25,960	34,760
3	Oil Producer	11,050	1,700	7,160	23,420	27,810
4	Oil Producer	10,950	4,700	10,590	23,190	30,310
5	Oil Producer	11,050	1,400	5,050	20,740	25,380
6	Water Injector	11,300	8,100	3,770	21,510	21,380
7	Oil Producer	10,950	4,000	3,740	24,440	27,260
8	Oil Producer	11,000	1,000	6,700	21,540	26,960
9	Water Injector	11,100	3,300	3,130	19,750	23,710
10	Water Injector	11,000	5,500	6,400	24,790	26,340
11	Oil Producer	10,800	7,500	13,460	25,330	33,130
12	Water Injector	11,100	4,500	2,400	20,370	23,110
13	Oil Producer	11,200	4,800	4,160	22,360	24,300
14	Oil Producer	10,900	6,200	12,200	23,640	31,610
15	Oil Producer	11,150	2,900	5,050	22,570	25,630
16	Water Injector	11,150	6,000	4,810	23,160	24,050
17	Oil Producer	10,950	4,800	11,040	24,570	31,240
18	Oil Producer	10,950	3,200	9,710	24,300	30,220
19	Oil Producer	10,950	4,300	9,700	21,550	28,960
20	Oil Producer	10,800	7,800	13,080	22,920	31,870
21	Water Injector	11,300	6,100	2,580	21,010	22,300
22	Gas Injector	10,750	8,300	14,040	24,260	33,000

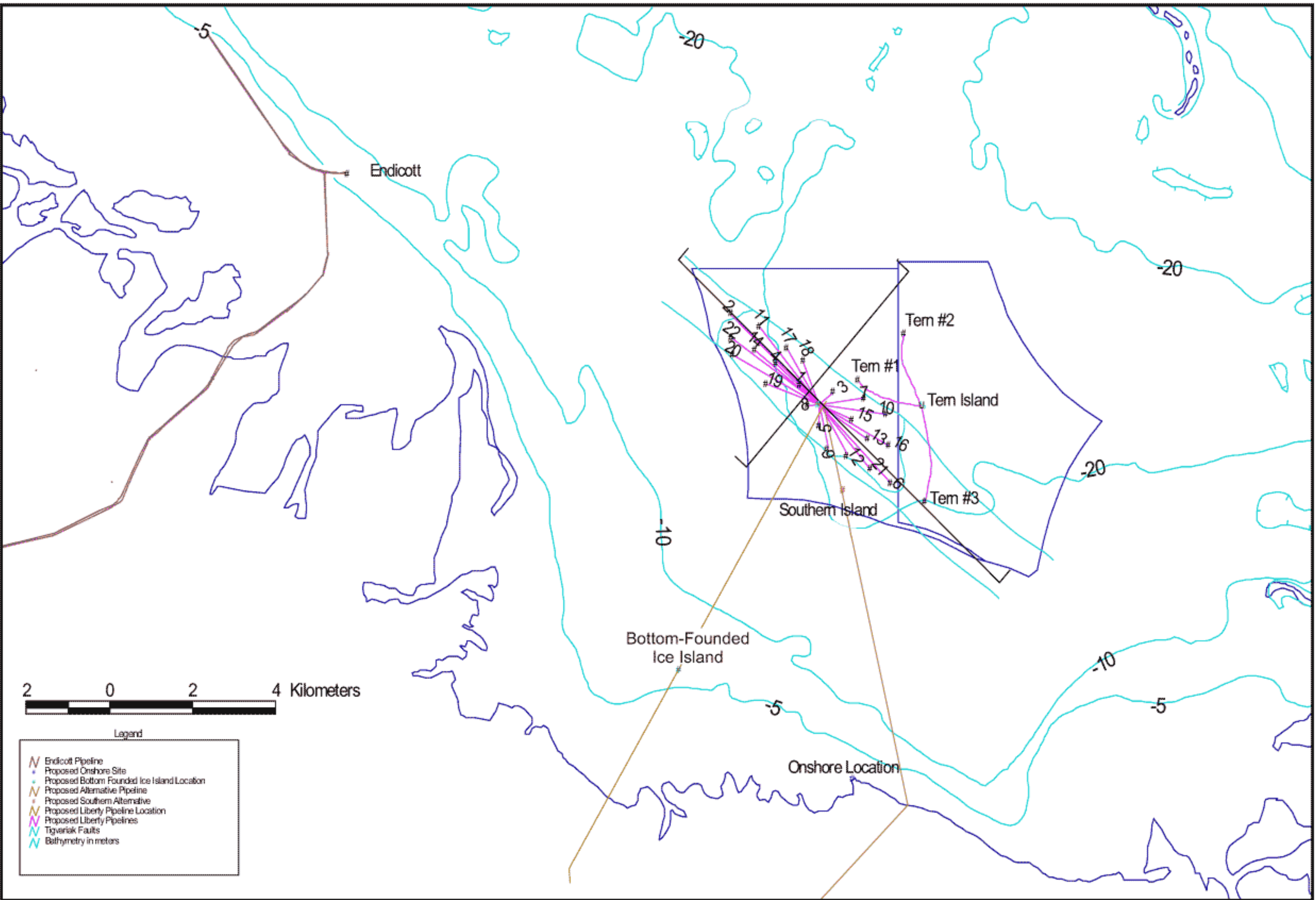
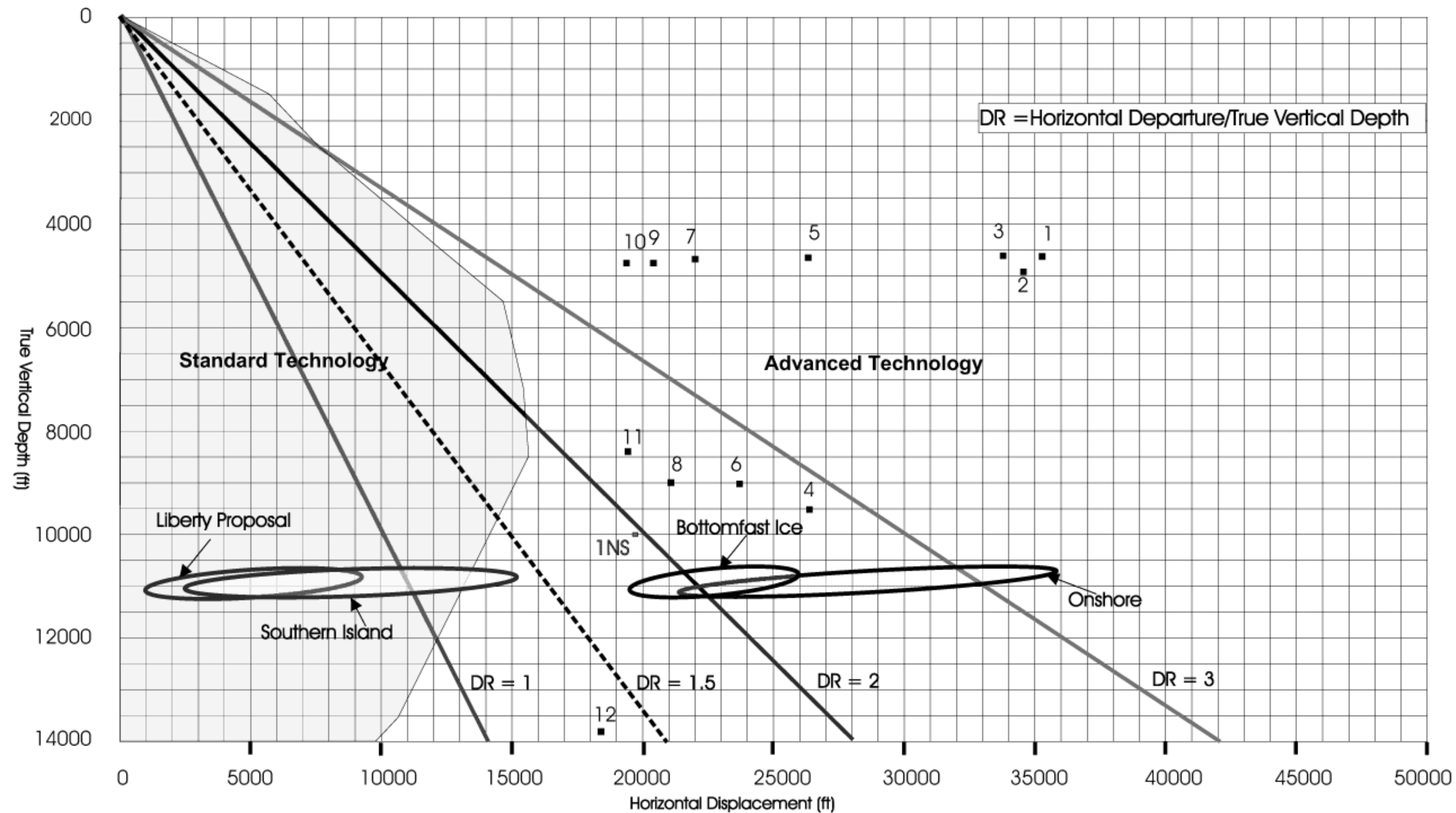

Figure D-3-1 Locations of Liberty Alternative Islands



North Slope Well
1NS, Niakuk NK-11A

- | | | |
|-----------------------|---------------------|----------------------|
| Existing Record Wells | ■ | |
| 1. Wytch Farm M-16 | 5. Wytch Farm M-05 | 9. ARA S7/1 |
| 2. Ara Field CN-1 | 6. Statoil 33/9 C-2 | 10. Wytch Farm M-06 |
| 3. Wytch Farm M-11 | 7. Wytch Farm M02 | 11. Statoil 33-9 C-3 |
| 4. Xijiang 42-3 | 8. Amoco SEER T-12 | 12. BP 2/1 A-13 |

Figure D-3-2 Comparison of Existing Extended-Reach Technology to Proposed Liberty Development Wells

**Final Report: Independent Evaluation of Liberty Pipeline System
Design Alternatives – Summary (Stress, 2000)**

This appendix was published as part of the Liberty Development and Production Plan (DPP) Draft Environmental Impact Statement (EIS) and was not revised for the Final EIS. The reader is referred to this appendix in the Draft EIS. This appendix is also available on the CD-ROM (MMS 2002-019 CD) and on the Internet (<http://www.mms.gov/alaska/cproject/liberty>).

Final Report:

Independent Evaluation of Liberty Pipeline System

Design Alternatives

RFQ No. 01-99-RQ-16132

P.O. Number 01-00-PO-16132

PN1996535GRR

Prepared for

Minerals Management Service

April 2000



STRESS ENGINEERING SERVICES, INC.

Houston, Texas

FINAL REPORT
INDEPENDENT EVALUATION OF LIBERTY PIPELINE
SYSTEM DESIGN ALTERNATIVES

PN1996535

Prepared for
Minerals Management Service

Prepared by: _____

George R. Ross
George R. Ross, Ph.D.

Reviewed by: _____

Joe R. Fowler
Joe R. Fowler, Ph.D., P.E.

Contributing Team Members

Jack E. Miller, P.E.

Paul J. Kovach, P.E.

Claudio Allevato, ASNT III

Carl G. Langner, Ph.D., P.E.



Stress Engineering Services, Inc.

13800 Westfair East Drive

Houston, Texas 77041

April 2000

SUMMARY

This report describes the work performed by Stress Engineering Services, Inc. (SES) in reviewing four candidate pipeline design concepts for the Liberty Development Project.

The proposed Liberty pipeline consists of a 12 inch nominal diameter pipeline approximately 7.6 miles in length. The pipeline will connect Liberty Island, a manmade island in Foggy Island Bay, to the existing Badami oil pipeline onshore. The 7.6 mile route includes approximately 6.12 miles which are offshore. The maximum water depth along the route is 22 ft at Liberty Island. Since the region is environmentally sensitive, it is of utmost importance that all reasonable measures be taken to protect the environment during the construction and operation of the pipeline.

The material provided for review consists of the November 1, 1999 report "Pipeline System Alternatives" prepared by INTEC Engineering, Inc. for BP Exploration. This report is referred to as the *INTEC report* throughout this document. We were also supplied with the July 1999 report "Northstar Development Project Prototype Leak Detection System Design Interim Report" and the August 1999 report "Northstar Development Project Buried Leak Detection System Preliminary Design and System Description" which were also prepared by INTEC Engineering, Inc. for BP Exploration. In this document, these reports are referred to as the *LEOS reports*. On February 29, 2000, we received a package of information from INTEC on the ice keel gouge finite element analysis. The package consisted of calculation numbers CN 0851.02.T19.301 and CN 0851.02.T19.302, both of which were issued July 20, 1999.

The INTEC report presents four primary candidate concepts, a single wall steel pipe, a steel pipe-in-pipe, a steel pipe-in-HDPE (high density polyethylene), and a flexible pipe system. Subalternatives are presented for three of the four candidates (there is not a subalternative presented for the flexible pipe system). The LEOS reports present information on the LEOS leak detection system which is part of the proposed Liberty pipeline monitoring system.

The primary goal of the review was to ensure that all of the candidate designs were considered equally and that the conceptual designs, construction methods, inspection techniques, repair methods, loads, cost estimates, and operations/maintenance practices were reasonable.

As part of the review we have come across a large number of items about which we have questions and/or comments/observations. Most of these comments are on minor issues which we are sure can be addressed easily or which the designers may intend to address during the preliminary or detailed design phases. We are confident that any of the four candidate concepts could be designed to fulfill the intended function of the pipeline. However, the concepts do have different levels of risk and different anticipated costs, both during installation and during the twenty year design life. Our comments/observations and questions are presented in the following subsections.

Design Issues

1. The INTEC report states that pipe-in-pipe designs are used for insulation or installation reasons. While this is true, this past practice should not exclude the potential for using a pipe-in-pipe system for leak containment or other legitimate reasons. It seems that the main advantage of the pipe-in-pipe and pipe-in-HDPE systems, the ability to contain small leaks, has been discounted.
2. It is our opinion that the HDPE sleeve used in the pipe-in-HDPE concept could contain small leaks, but could not contain the operating pressure of the pipeline. However, it should be noted that a small leak in the inner pipe would not result in the HDPE sleeve being immediately subjected to the operating pressure of the pipeline. Therefore, we expect that there would be time to detect the presence of oil in the annulus with either the LEOS system or by pressure fluctuations in the annulus before the burst pressure of the HDPE sleeve was reached. Furthermore, the bulkheads at each end of the pipeline could be fitted with a pressure relief system that keeps the pressure in the annulus from exceeding the burst pressure of the HDPE sleeve. This

pressure relief system could be connected to a reservoir which would prevent any oil leaked into the annulus from entering the environment.

3. The outer pipe of the steel pipe-in-pipe could not only contain small leaks, but could also contain the operating pressure of the pipeline. This design, like the pipe-in-HDPE design, could also be fitted with sensors to monitor the pressure of the annulus and a reservoir which would prevent any oil leaked into the annulus from entering the environment. Since the outer steel pipe can withstand the operating pressure of the pipeline, it is feasible that the pipeline could remain in operation even if there was a leak in the inner pipe. At a minimum this would mean that if the inner pipe develops a leak, the oil could be pumped from the pipeline before repairs are made. Unless both the inner and outer pipes were leaking simultaneously, this would prevent oil from entering the environment. This contrasts with the single wall pipe concept in which any leak would cause both an oil spill and an automatic shut-in of production from the facility until the pipeline is repaired.
4. We are concerned that the INTEC report has chosen to minimize the burial depth of each concept. This choice prejudices the equal comparison of the different concepts. Another issue which makes the comparison of the designs unequal is that the inner pipe (flowline) of the steel pipe-in-pipe concept is thinner than the single wall pipe. We would have preferred that the burial depths and the flowline wall thicknesses of all the alternatives be identical to that used in the single wall pipe concept. However, the effect of the change in pipe wall thickness on the equal weighing of the alternatives is minor in comparison to the effect of the burial depth. By assigning different burial depths to the different concepts, the benefit of using an alternative design (as opposed to a single wall pipe) can be lost. The single wall pipe is picked as the best pipeline system candidate. However, the risk of an oil leak is primarily a function of the burial depth and the single wall pipe is buried the deepest. While the chosen depths appear appropriate for each design concept, we would adopt a different approach. The depth of cover for the single wall pipe is 7 feet. We would prefer to keep this depth constant for all of the concepts. If this were done, questions would be answered as to how much benefit do you get when an outer pipe is added to a single wall pipe (i.e., If the only change is adding the outer pipe, what is the benefit?).

5. The driving forces behind considering the alternative concepts are not stated. The purpose of considering such alternatives would be some perceived improvement over a traditional single wall design. We feel that there should be a clear statement of the perceived benefits of the pipe-in-pipe, pipe-in-HDPE, and flexible pipe concepts.

Technical Merits

1. As mentioned in our intermediate report, we have concerns about the finite element modeling of the ice keel soil/pipe interaction using ANSYS. The cause of concern here is that the geometric nonlinearity was not included in the analysis. We have spoken with the INTEC representatives, Michael Paulin and Andre Nogueira, about the exclusion of the nonlinear geometric effects from the finite element analysis. Their reasoning behind neglecting the nonlinear geometric effects appears to be due to the increased run time which would have resulted. There were some checks made of the pipe-in-pipe and single wall steel pipe which included the nonlinear geometric effects. However, these check runs have not been through INTEC's quality assurance checks. From our conversation with INTEC, the check runs showed that the trends in the strains remained the same when the nonlinear geometric effects were included as when the nonlinear geometric effects were neglected. Therefore, they used the runs that neglect the nonlinear geometric effects for the conceptual design. We think that this topic is in a gray area between conceptual and preliminary design. In our opinion, if the finite element analysis was felt to be needed at this level, then both the geometric and material nonlinearity should have been included. It may be prudent to use the conceptual design phase to narrow the candidates from four to two and perform the finite element analysis on the two final candidates including the nonlinear geometry effects before selecting the final candidate.
2. We understand that there is another contract for the review of the spillage probability and damage calculations. We consider this an important activity since, the INTEC report definition of a small chronic leak (Category 3 damage, see p 5-38) appears unrealistically low at only 1 barrel a day. Even a 1 inch long crack 0.001 inches wide

could discharge approximately 29 bbls/day from an 1100 psi line. A 1 barrel/day leak from an 1100 psi line corresponds to a 0.007 inch diameter hole.

Inspection Issues

1. The main method for inspection of the pipeline, with regards to internal and external corrosion will rely on the use of smart pigs to be run inside the pipe. In the event the pipe curvature is changed by loads such as ice keel gouging or upheaval buckling, there is a possibility the instrumented pig may not be able to go through the pipe. We recommend that INTEC review this possibility, and investigate methods for solving this problem, in case it arises. The point is that the ability of the pig to pass through the line may be more limiting than the allowable strain in the pipe.
2. As we understand the current LEOS system, the system uses a small tube which is permeable to hydrocarbons and the contents of this tube would be checked once every 24 hours to determine if a small leak is present. The time required to check the contents of the tube would be approximately six hours. Therefore, there is an eighteen hour hold time during which the hydrocarbons have time to permeate the LEOS tube. As the system exists, Siemens estimates that a leak as small as 0.3 bbls/day could be detected. However, we understand that for the steel pipe-in-pipe and pipe-in-HDPE alternatives that the air in the annulus might be sampled instead of installing a sampling hose. Our concern with this method has to do with the ability to detect the location of a leak. The leak locating abilities of the LEOS system depend on determining where in the flow stream the hydrocarbons are located. The proposed pipe-in-pipe and pipe-in-HDPE designs have centralizers in the annulus. This makes the flow characteristics in the annulus more complex than in a tube and mixing of the air in the flow stream would be expected. We expect that the more complex flow characteristics will make it more difficult to locate a leak. However, there may be an advantage in that the hydrocarbons do not need to permeate a LEOS tube before being detected if the entire annulus is sampled. Whichever method is chosen, we would recommend that a third party demonstration test be conducted on the

supplemental leak detection system in the same configuration as would be implemented in the Liberty project.

3. In terms of the mass balance and pressure point systems, our primary concern is with false alarms. The concern here is that if the system does not contain self diagnostics that minimize false alarms, the operators will summarily dismiss an actual leak as a false alarm. In order to prevent this, a system should be adopted that has capabilities that allow the operator to accurately determine the difference between an actual leak and a false alarm and self diagnostics to minimize false alarms.
4. For the flexible pipe system, a disadvantage that is not mentioned in the INTEC report is that the flow balance calculations become more complex. The flexible line can be expected to expand under pressure more than a steel pipe would. This would mean that the variation in the internal volume of the line due to internal pressure will be greater than for a steel pipe and may affect the flow balance calculations.
5. The leak detection threshold of 0.3 BOPD by Siemens is stated, in the LEOS reports, to have been based on experience. The accuracy of this estimate is difficult to assess because it depends on a variety of factors such as the permeability of the soil if the tube is buried beside a pipeline, the size of the annulus if the tube is in the annulus, the permeability of the sensor tube, the location of the tube in relation to the leak, and the hold time between sampling runs. The ability to detect a leak using the LEOS system is dependent on the concentration of oil around the sampling tube. Therefore, the question one should ask in regards to the leak detection threshold is what concentration of oil around the sampling tube is required before a leak can be detected. Once this is known, one would assume that the tube is located at the furthest possible position from the leak and determine either experimentally or numerically the time necessary for the oil concentration around the tube to reach a detectable level for a given leak rate. Such analysis/experimentation is beyond the scope of this review. We would recommend that a third party demonstration test be conducted using the configuration proposed for the Liberty project supplementary leak detection system.
6. For the flexible pipe system, there is not a true annulus. The INTEC report states that the sampling for leak detection would occur in the annulus, but this annulus is filled

with steel strips. One would be counting on being able to pump clean air through an annulus that contains steel wraps. This seems unlikely to work. It also seems unlikely that oil could be extracted from this annulus. The ability of the system to sample from this annulus, with internal pressure applied to the pipe, needs to be confirmed. Does BP have any data to confirm that this sampling is possible?

7. For the flexible pipe system, jumpers across the connections are to be used to provide a continuous pathway for the leak detection system to sample the air in the annulus. It is not clear how this would be accomplished. Have any conceptual designs of these jumpers been proposed?

Operations Issues

1. The INTEC report states that the pipeline will be shut down if pressure or temperature limits are exceeded. Our concern about this is that flow assurance problems may be encountered if the pipeline cools with oil in the line. If the oil properties at ground temperature are such that the oil can still flow, this may not be a problem. However, for some oil compositions at low temperatures, blockages could form when the line is shut down and make it difficult to restart the line. We would be interested in seeing a restarting procedure in case such a shutdown takes place.
2. We would suggest that the annulus pressure be monitored for the pipe-in-pipe and pipe-in-HDPE concepts. A pressure buildup in the annulus could be indicative of a leak in the inner pipe. This would provide another avenue for leak detection in addition to the mass balance and pressure point systems which operate continuously and monitoring either the annulus contents or the contents of a LEOS tube which would be done once a day.

Repair Issues

1. It is stated that repair could not occur at some times during the year, specifically during break-up and freeze-up of the ice sheet (pages 1-6 and 3-33 of the INTEC report). This amounts to approximately 5-6 months out of the year. It would seem

that this would have an effect on the amount of oil lost. The pipeline would be shutdown, and clean-up would proceed, but there would still be oil in some parts of the line. Is it possible for oil that remains in the pipeline to continue to leak before repairs could be made? Has this been taken into account in the oil spillage calculations?

2. For cases where there is an annulus, in order to prevent corrosion, all moisture would need to be removed from the annulus after a repair. The drying operations following a repair would be more difficult than the drying operations after initial construction because of debris drawn into the annulus during the damage period and the subsequent repair activities. Such debris would include soil, sand, and gravel, in addition to seawater and hydrocarbons. Not all of these materials and objects would be removed by the drying process and may increase the time necessary to dry the annulus. As a result, a significant amount of moisture could be present for a long period of time (i.e., the 2.5-3 month period when repairs could not be made during a freeze-up or break-up plus the drying time). We would expect that drying the annulus could take a month or more. This means that moisture would be present on the order of 4 months. This would be more than enough time for corrosion to begin in the annulus. Therefore, installing a cathodic protection system on the inner pipe should be considered. Such a system could consist of a sprayed aluminum or other cathodic coating applied to the inner pipe to provide in-situ cathodic protection. Another method would be to attach anodes to the inner pipe. Either of these methods should supply adequate cathodic protection for the inner pipe. The drawback to this is that the cathodic protection of the inner pipe could not be monitored.
3. Mechanical repair devices are used as permanent repairs around the world. These devices include external leak repair clamps as well as in-line pipe coupling devices. However, the INTEC report states that mechanical repairs are not considered appropriate for permanent arctic offshore repairs. Is there engineering evidence that supports this or is this based on a perceived risk?
4. We are aware that both bolted and welded split sleeves are commonly used for the repair of small leaks. However, it is not clear which kind of sleeve is being

referenced in the INTEC report. It would be helpful if drawings of the candidate repair equipment and installation method were included in the report.

5. We agree that the repair of the pipe-in-pipe design would be much more involved and that the restoration of the outer pipe to original integrity is doubtful given the types of repairs described. From the INTEC report, we envision the proposed repair of the outer pipe to consist of a clamshell that has a larger diameter than the outer pipe. Using such a repair would result in having to use fillet welds on the ends of the repair section and would include longitudinal welds to join the clamshell sections. This type of repair is illustrated in Figure 3 and would not restore the outer pipe to its original integrity. However, if the repair pipe has the same diameter, wall thickness, and material properties as the original pipe and is installed using butt welds that are inspected by UT examination, it should be possible to restore the pipe to near its original integrity. This type of repair is included in Figure 4. The repair includes longitudinal welds, but the fillet welds are replaced by butt welds. In order to implement this type of repair, the ends of the pipe would have to be prepared and the repair section cut to length in the field. When designing the pipeline, the designers should consider the capacity of a repaired pipe when establishing the design allowables. If the repaired pipeline would not be as sound as the new line, the design allowables should be based on the repaired pipe strength.
6. We have a few questions concerning the repair of the flexible pipe alternative. Why is a flanged connection considered temporary? Is there standard repair equipment for flexible pipe? What do the repair connections look like? How could/would end fittings be installed in the field? It appears that any permanent repair to the flexible pipe system would consist of replacing an entire 2800 ft section. This significant effort may increase the repair costs of the line enough to offset any initial savings of using the flexible pipe system. Replacement sections would have to be kept on site, or production could be halted for months waiting for a replacement section.
7. The INTEC report discusses both repair time frames and methods of repair. Our experience has been that the delivery of mechanical connectors or bolted split sleeves can be on the order of two months. We would also expect that connectors constructed

of materials appropriate for the arctic environment could take even longer to obtain. Is there a plan for stocking the discussed products locally?

Construction Issues

1. There is no mention of the procedures which would be required to abandon an uncompleted line and then successfully resume construction. Has this been considered?
2. For the concepts involving inserting the inner pipe into an outer pipe or sleeve, there is a possibility of damage to the corrosion protection coating during this operation. Emphasis is placed on keeping the annulus dry to prevent corrosion and that the inner pipe would not be cathodically protected. It would seem prudent to include some cathodic protection of the inner pipe. This cathodic protection could consist of a sprayed aluminum or other cathodic coating or anodes attached to the inner pipe. The drawback here is that the cathodic protection in the annulus could not be monitored. However, the system would be in place and could provide some benefit.
3. In the pipe-in-pipe construction sequence, it is stated that the “inner pipe extends beyond the outer pipe”. The inner and outer pipes must be the same lengths eventually so this statement is not clear. It would seem that the first section should be made with a short outer pipe. The rest of the inner and outer pipes should be made the same length but the inner pipe sticks out at the first field weld so that this weld can be made and inspected. The outer pipe would then be slid over this weld and the outer field weld made and inspected. Is this the intended method?
4. Induction heating is mentioned as a method of joining the HDPE pipe and later a fusion joining machine is mentioned. Which is the intended method and what are the implications of the joining method to the construction process?
5. For the flexible pipe alternative an area of concern is the welding of the connectors and their subsequent coating. The integrity of this system depends on these joints so the fabrication and long term performance needs careful attention.
6. For the pipe-in-HDPE concept, it is stated that only visual inspection of the fusion welds is possible. We agree with this and that the best avenue for assuring the quality

of the fusion welds is to qualify the procedure using test samples fusion welded by the same machine and operators as would be used during installation.

7. We agree that both the steel pipe-in-pipe and pipe-in-HDPE alternatives would be more difficult to construct than either the single wall steel pipe or the flexible pipe. However, there are some refinements to the construction process that could reduce the time required to install the steel pipe-in-pipe and pipe-in-HDPE alternatives. First, the single wall steel pipe strings that are to be towed to the trench are 3000 ft long. However, the pipe-in-pipe and pipe-in-HDPE strings are only 1000 ft long. This increases the number of tie-in locations by a factor of three. In addition, the time to make each connection is longer for the pipe-in-pipe and pipe-in-HDPE alternatives because of the additional connection of the outer pipes or sleeves. It would seem that the main factor affecting the length of the string that can be towed is the weight of the string. For the steel pipe-in-pipe, a 1300 ft string is approximately the same weight as the 3000 ft single wall steel pipe string. If 1300 ft strings were used, the number of tie-in locations would be reduced from 33 to 25 and the connections could be made in approximately 8 fewer days. For the pipe-in-HDPE alternative, 2600 ft strings weigh approximately the same as the single wall steel pipe 3000 ft string. Using 2600 ft long pipe-in-HDPE strings would reduce the time for the field joints from 22 days to 9 days. In both cases, preparing longer strings would increase the pipe string make-up time. However, this could be offset by increasing the size of the crew. Another way to speed up the construction would be to use two pipelaying spreads either starting in the middle of the route and working toward opposite shores or starting onshore and working toward a central tie-in. In the INTEC report, the construction timelines for the single wall, steel pipe-in-pipe, and pipe-in-HDPE, start in mid December and end in mid April. The timeline for the flexible pipeline is shorter running from mid December to mid March. However, the INTEC report states that the ice is stable in Zone 1 by December and break-up occurs at the end of May. Therefore, it would seem that equipment mobilization, road construction, and make-up site preparation could begin December 1st and construction could continue through May. This amounts to eight weeks that are currently not included in the construction timeline. If half of this time is discounted for weather variations, there are four weeks

that could be included in the construction timeline or 28 days more time available for construction than included in the current timeline. The longest timeline is currently 107 days for the pipe-in-HDPE alternative. An increase in the timeline of 28 days constitutes a 25 % increase. Therefore, we feel that with proper scheduling and the mobilization of adequate numbers of trained personnel it should be possible to complete the construction of any of the four designs in one season. The keys to completing the work in one season are to make sure that the preparation of the pipe strings proceeds at a rate that keeps up with or exceeds the trenching activities and minimizing the number of field joints. In other words, the trenching activities should be the limiting factor in the construction timeline. The main advantage to the construction method presented in the report is that the strings can be fabricated before trenching is started. If the pipe strings could be completed in the fall, before the winter freeze-up or enough manpower is allocated to ensure that the pipe string preparation exceeds the trenching rate, it should be possible to complete the pipeline in one season. With any of the alternatives, the possibility of construction requiring a second season is present and should be considered when the construction is planned. However, we feel that if a single wall pipe can be constructed in one season, then the other alternatives could also be completed in one season. It would be the factors that are unpredictable, such as an unusually short winter, which one would expect to result in a second construction season and these unpredictable factors would affect any of the designs.

8. We would suggest, if scheduling permits, that the hydrotest of the pipeline be conducted before backfilling. The main factor affecting the ability to hydrotest before backfilling is scheduling. The INTEC report estimates that backfilling activities will take between 30 and 44 days, a significant percentage of the construction season. If waiting to backfill until after hydrotesting would result in a second construction season, then backfilling should proceed as the pipe is installed. However, if the hydrotest could be conducted before backfilling, this would facilitate any repairs that need to be made. In addition, maintaining some pressure in the line during the backfilling operation should be considered. This would lock in some

tensile stresses in the pipeline, which would help reduce the effects of the thermal expansion that will occur as the pipeline heats up to its operating temperature.

9. As an alternative to a hydrotest of the annulus of the pipe-in-pipe and pipe-in-HDPE alternatives, the annulus could be tested using pressurized dry air or dry nitrogen. During this test, a diver or ROV could “walk” the pipeline route and look for bubbles. Any leaks in the outer pipe or sleeve would be indicated by bubbles.
10. The INTEC report mentions that localized jetting may be necessary to fluidize the trench bottom in order to lower a pipe that has become “high grounded” during installation. This means that jetting equipment will need to be on site throughout the pipelaying process. Otherwise, if jetting is required, delays in getting the equipment could prevent the completion of the pipeline in one season. In addition, suction equipment may be needed to remove material from localized high spots.

Costs

1. The 5 million dollar contingency for a second construction season of the pipe-in-HDPE candidate appears low. We understand that INTEC based this on the perceived likelihood of a second season being required to complete construction. However, the costs for mobilization, ice thickening/road construction, and demobilization for the pipe-in-HDPE concept total 9.7 million dollars. There are also no costs included for the abandonment of the line at the end of the first construction season and the retrieval of the partially completed pipeline so that construction can be resumed. Therefore, the 5 million dollar contingency for the second season work seems low. For the steel pipe-in-pipe, the contingency cost allocated for a second season of 15 million dollars is more reasonable.
2. We feel that it should be possible to complete construction of any of the alternatives in one season. This would have the most effect, in terms of cost, on the steel pipe-in-pipe alternative. Completing the construction of the steel pipe-in-pipe in one season would reduce the cost by 15 million dollars and bring the pipe-in-pipe costs closer to the single wall steel pipe cost.

Alternative Design Concepts

1. We would be interested in knowing if concepts such as putting a flexible, composite, or polymer pipe inside a steel pipe have been considered. If so, what factors eliminated this option from consideration? It would be more difficult to install than a single wall pipe, but we would think that it would be easier to construct than the steel pipe-in-pipe. If the inner pipe was nonmetallic, the concern about cathodic protection of the inner pipe would be eliminated. One issue that would need to be addressed is how to prevent damaging the inner nonmetallic pipe when the outer steel pipe is welded.
2. There is a modification to the steel pipe-in-HDPE concept that we would suggest investigating. The HDPE sleeve could be prefabricated as a unit with an inner thin wall HDPE pipe and an outer HDPE pipe with the foam in-between. In order to use this HDPE sleeve with the foam in place, an adequate installation clearance between the thin wall HDPE pipe and the inner pipe would be required. A further variation would be to perforate the thin wall HDPE pipe and replace the polyurethane foam with an oil absorbent material. In this scenario, the HDPE sleeve assembly becomes an oil containment barrier and a leak detection system could monitor the annulus between the steel pipe and the perforated thin wall HDPE pipe. A sketch of this alternative is included as Figure 1 in this report.
3. Another variation to the steel pipe-in-HDPE concept would be to use a thick wall (16 inch O.D. x 1.25 inch wall) HDPE sleeve without centralizers. The closer fit between the HDPE sleeve and the inner pipe and elimination of the centralizers would provide better distribution of the inner pipe weight to the HDPE sleeve. This may lower the risk of damaging the HDPE sleeve when handling the assembled pipe strings. The thicker wall HDPE sleeve would also have a higher allowable pressure and the elimination of the centralizers would simplify construction.

Items to be Considered in Preliminary Design

1. For the pipe-in-pipe concept, it is stated that there will be a locked in compressive load in the inner pipe. There will be centralizers/spacers in the design to keep the curvature of the two pipes approximately equal. The inner pipe should be checked for buckling between the centralizers due to the thermal expansion if this design concept is carried forward. Buckling could lead to a fatigue failure or to fretting at points of contact between the two pipes if the temperature fluctuations are sufficient.
2. A possible hydrostatic test of the outer pipe is mentioned on page 5-17 of the INTEC report. This would require drying of the annulus after the hydrotest. In addition, if such a test is done the inner pipe must be pressurized or otherwise assured of being collapse resistant. Collapse should not be a problem with the currently proposed inner pipes, but should be included in the preliminary design checks.
3. For the pipe-in-HDPE concept, the pipe transport method mentioned is the same as for the pipe-in-pipe technique. The spacers between the inner pipe and the HDPE outer sleeve are not described in any detail. However, the spacers must be designed so that the weight of the inner pipe is distributed along the length of the HDPE sleeve. The inner pipe is so heavy that the ability of the HDPE sleeve to carry this load, unless it is well distributed, is doubtful. An alternative would be to use a thicker walled HDPE sleeve and a smaller annulus size and omit the centralizers. This would distribute the weight of the inner pipe over a larger area than if centralizers were present. This would also aid in construction since the centralizers would not be installed. Buckling of the inner pipe would have to be considered in detail in the preliminary design phase if such a concept were adopted. The possible impact loads during construction/transport should also be considered since the impact strength of HDPE at -50°F can be expected to be approximately $\frac{1}{2}$ that of HDPE at 73°F .

DISCLAIMER

Stress Engineering Services has performed a review of the documentation provided by the Minerals Management Service and INTEC. This documentation consisted of the November 1, 1999 report "Pipeline System Alternatives", the July 1999 report "Northstar Development Project Prototype Leak Detection System Design Interim Report", the August 1999 report "Northstar Development Project Buried Leak Detection System Preliminary Design and System Description" prepared by INTEC Engineering, Inc. for BP Exploration, conversations with David Roby of MMS, a conversation with Michael Paulin and Andre Nogueira of INTEC, and a package of information from INTEC on the ice keel gouge finite element analysis consisting of calculation numbers CN 0851.02.T19.301 and CN 0851.02.T19.302. This review is at the level of conceptual design only. Stress Engineering Services has not performed any detailed design or stress analysis work that would be required to ensure that any of the pipeline design concepts discussed in this document are safe to install and operate.

Evaluation of Pipeline System Alternatives: Executive Summary (INTEC, 2000)

This appendix was published as part of the Liberty Development and Production Plan (DPP) Draft Environmental Impact Statement (EIS) and was not revised for the Final EIS. The reader is referred to this appendix in the Draft EIS. This appendix is also available on the CD-ROM (MMS 2002-019 CD) and on the Internet (<http://www.mms.gov/alaska/cproject/liberty>).



LIBERTY DEVELOPMENT PROJECT

EVALUATION OF PIPELINE SYSTEM ALTERNATIVES: EXECUTIVE SUMMARY

BP Exploration (Alaska), Inc. (BPXA) submitted a Development and Production Plan (DPP) for its proposed Liberty Development in February 1998. As discussed in the DPP, BPXA plans to produce sales-quality crude oil at Liberty Island, located in Foggy Island Bay approximately 6 miles offshore of Alaska's North Slope in the Beaufort Sea. Liberty will be a self-contained drilling and production facility built on a manmade 5-acre gravel island in about 22 feet of water (Figure 1). According to the DPP, the oil will be delivered from Liberty to the trans-Alaska pipeline by means of a 12-inch-diameter pipeline approximately 7.6 miles from Liberty Island to a tie-in with the existing Badami oil pipeline, which connects with the Endicott oil pipeline.

The 6.1-mile offshore segment of the Liberty oil pipeline is the most challenging aspect of the project, since the pipeline must be built in the nearshore landfast ice zone of the Beaufort Sea. BPXA retained INTEC Engineering, Inc. of Houston, Texas, to prepare a conceptual engineering report to evaluate and present the design alternatives for the pipeline. The report provides permitting and resource agencies information for evaluating alternatives in the Liberty Environmental Impact Statement. A peer review of these conceptual designs will be conducted by an independent engineering contractor selected by the agencies.

The INTEC report reviews four design alternatives, which are shown in Figure 2:

- Single wall steel pipeline
- Steel pipe-in-pipe system
- Single wall steel pipe inside HDPE (high-density polyethylene) sleeve
- Flexible pipe system

In order to fully evaluate these alternatives, the report covers:

- Project design criteria applicable to all alternatives
- Installation methods available for all alternatives
- Construction costs
- Operations and maintenance issues
- System reliability
- Leak detection systems

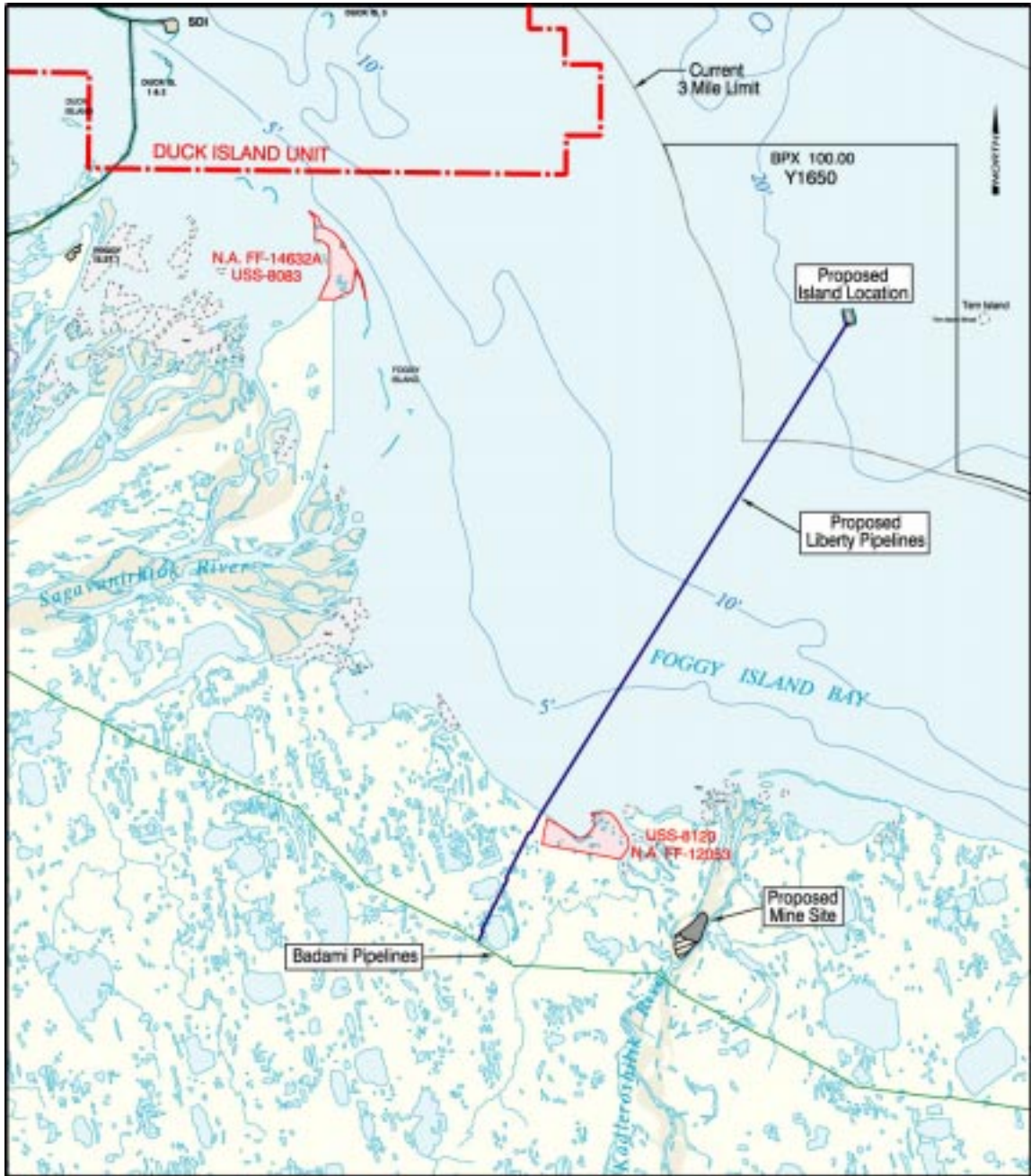

**FIGURE 1
LIBERTY PROJECT LOCATION MAP**

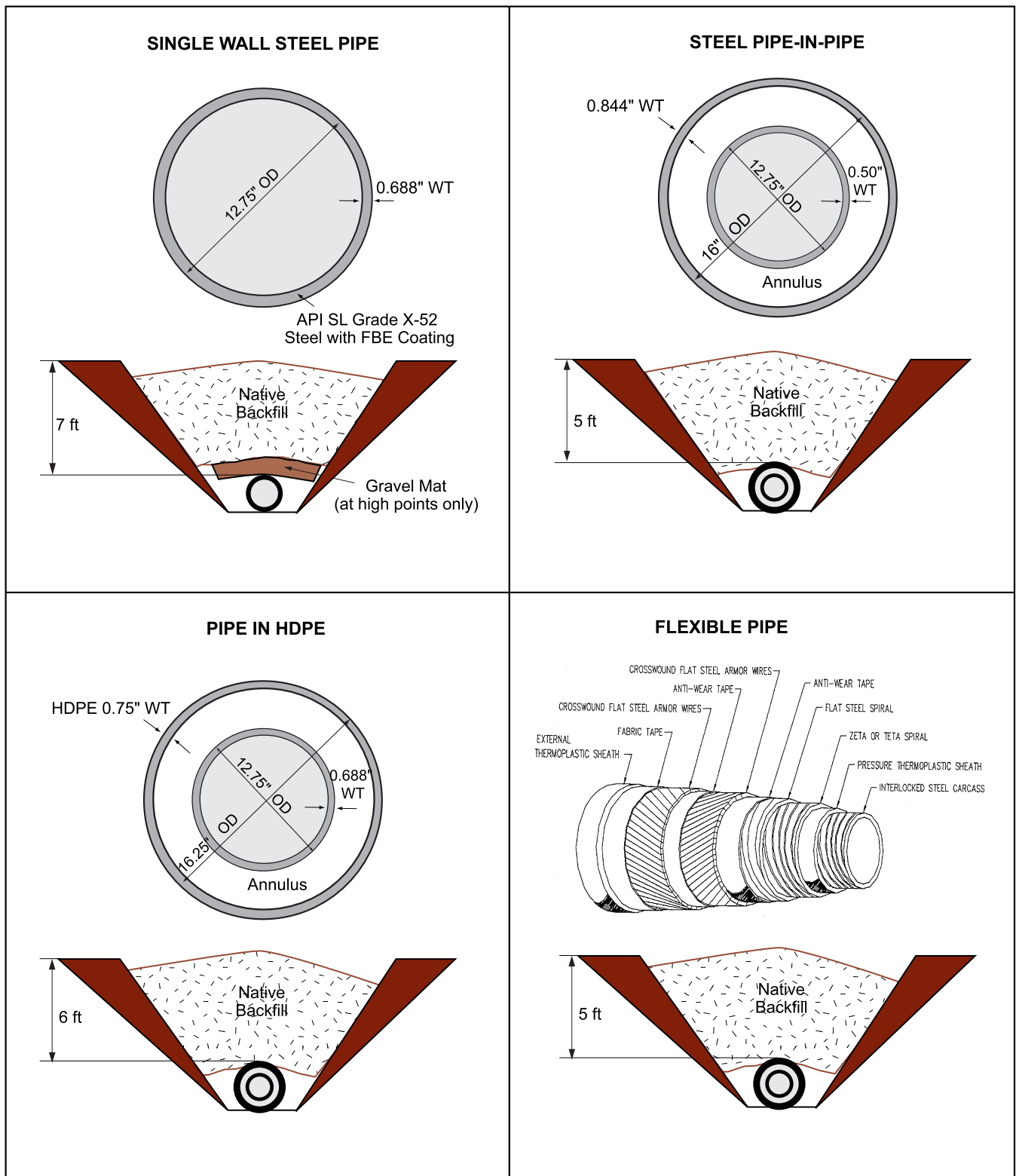

**FIGURE 2
LIBERTY PIPELINE ALTERNATIVES**

1. SUBSEA PIPELINE DESIGN BASIS

1.1 Safety Requirements

Any pipeline alternative must be designed for safe installation and operation. Safety requirements for a subsea arctic crude oil pipeline are based on a combination of government regulations, industry design codes, and project-specific engineering evaluations:

- U.S. Department of Transportation (DOT) Pipeline Safety Regulations, 49 CFR Part 195, Transportation of Hazardous Liquid by Pipeline.
- ASME B31.4 Code for Pipeline Transportation Systems for Liquid Hydrocarbons and Other Liquids.
- API RP 2N, Recommended Practice for Planning, Designing, and Constructing Structures and Pipelines for Arctic Conditions.
- Pipeline Design Technical Review – Liberty system alternatives are reviewed through the ongoing U.S. Minerals Management Service (30 CFR 250 Subpart J) and Alaska right-of-way lease procedures (A.S. 38.35), and industry peer reviews.
- State of Alaska Regulations – 18 AAC 75 includes specific design requirements for leak detection and also requires a best available technology review of certain pipeline system components (e.g., leak detection, cathodic protection, and communications systems).

1.2 Additional BP Design Objectives

In addition to regulatory and project-specific design requirements, the subsea pipeline system alternative should satisfy the following design objectives:

- Exceeding minimum Alaska State regulatory requirements for crude oil pipeline leak detection (18 AAC 75). The two state-of-the-art leak detection systems presently in use on existing North Slope pipelines and proposed for all Liberty pipeline system alternatives exceed these requirements.
- A supplemental leak detection system is desirable to detect smaller leaks before they can accumulate large volumes of spilled oil during the ice-covered season.
- Pipeline inspection pigging should monitor pipe conditions which could lead to a potential leak formation if uncorrected. This includes periodic wall thickness measurement, pipe body ovalization, and pipe geometry (bending) monitoring inspections with tools run through the pipeline.
- Pipeline construction during the winter ice-covered season is desirable for minimizing environmental impacts.
- Reasonable pipeline capital costs are required to support development economics.

1.3 Pipeline Design Criteria

A buried subsea pipeline must be designed to withstand the forces applied to it by the oil in the pipe and by any environmental events that have the potential to act on the pipeline. Table 1 summarizes these forces.

TABLE 1
DESIGN BASIS FOR LIBERTY PIPELINE ALTERNATIVES

CRITERIA	SPECIFICATION
Crude Oil API Gravity	25.4°
Crude Oil Specific Gravity	0.9 (@60°F)
Design Oil Flowrate	65,000 bbl per day
Pipeline Length (subsea section)	6.1 miles
Maximum Pressure at Badami Tie-in	1,050 psig
Maximum Allowable Operating Pressure	1,415 psig
Maximum Operating Temperature (at inlet)	150°F
Minimum Flowing Temperature: (at inlet)	120°F
Lowest Ambient Air Temperature:	-50°F
Design Ice Gouge Depth in Seafloor	3 feet
Design Strudel Scour Span	≈1 foot
Design Thaw Settlement (single wall steel)	1 foot
Design Prop Height for Upheaval Buckling	1.5 feet

The design oil flowrate is 65,000 barrels per day based on reservoir and field production considerations. This, in turn, establishes the minimum temperature and inlet pressure at the tie-in of the Liberty pipeline with the Badami pipeline. The pipeline internal diameter is established based on **pipeline length, flowrate, and pressure**.

The **pipe submerged weight** is a key design parameter since the pipeline must be heavy enough to sink and stay in the trench during installation. When the trench is excavated and then backfilled after the pipeline is installed, a slurry of soil and sea water may form in the trench bottom. The required pipeline submerged weight to counteract the buoyancy imparted by the slurry affects the pipeline configuration and installation procedure.

Two key factors determine how deep the pipeline would be buried in the seabed. The first is the **depth of cover**, which is defined as the distance from the top of pipe to the original undisturbed seafloor. Adequate depth of cover is important for protecting the buried pipe from loads induced by “ice keel gouging” and “strudel scour.”

- **Ice Keel Gouging:** During fall freeze-up and spring breakup, sea ice in the Beaufort Sea tends to pile up at some locations creating pressure ridges, some of which have keels that periodically form gouges into the seabed. Therefore, proper design requires establishing the extreme-event ice gouge depth along the pipeline route. However, in addition to being buried below the design expected ice gouge depth, the pipeline must resist strains caused by potential seabed soil movements from the gouge (Figure 3). The pipeline depth of cover (measured from the original seabed to top of pipe) performs this task. Based on an analysis of extensive data on the pipeline route, a design gouge depth of 3 feet will be used which is more than two times deeper than observed values.

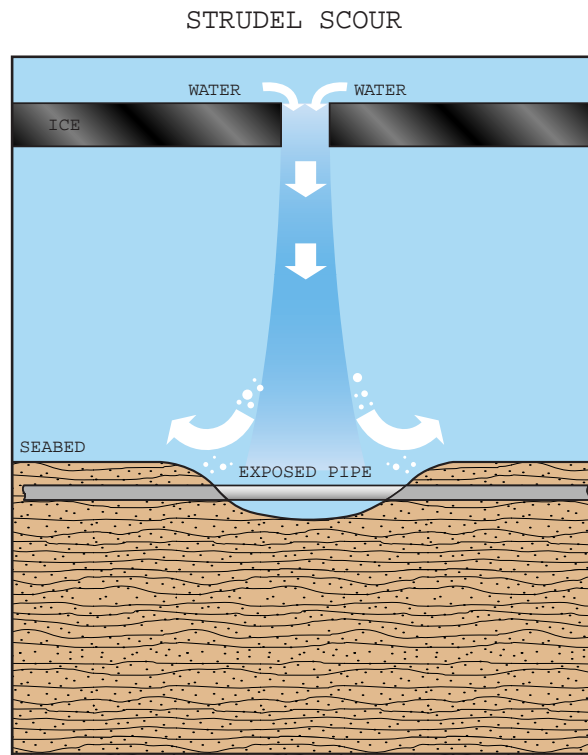
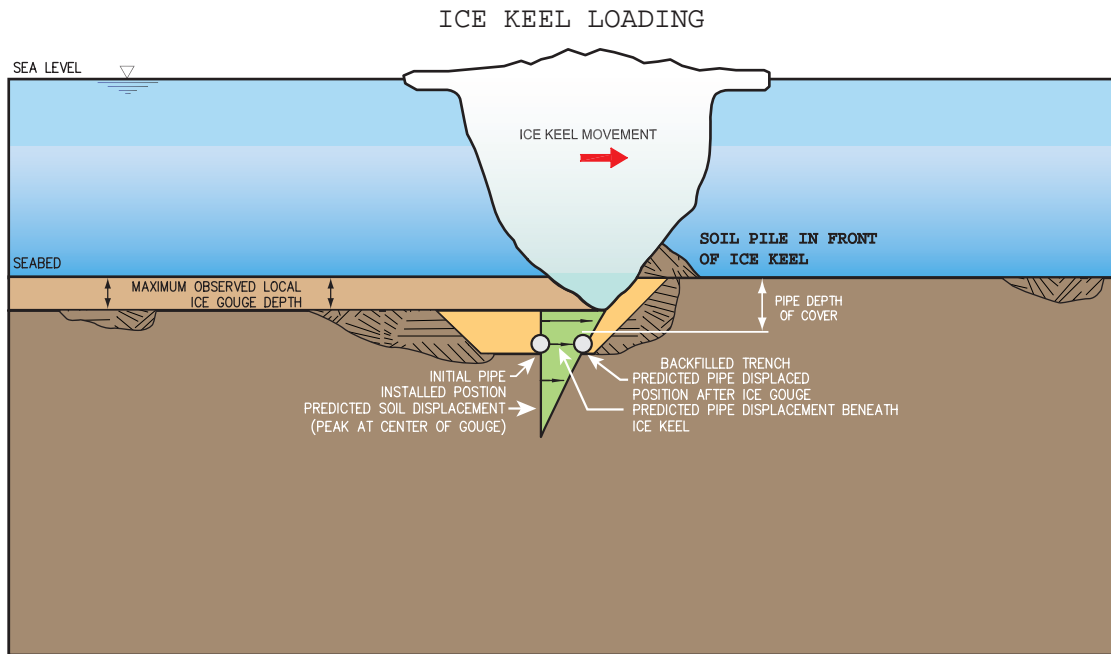

**FIGURE 3
ICE KEEL LOADING AND STRUDEL SCOUR**

UPHEAVAL BUCKLING

A) AS-LAID

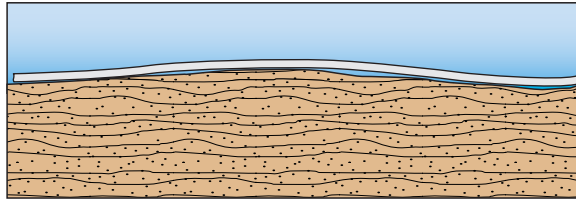

B) TRENCHED AND BURIED

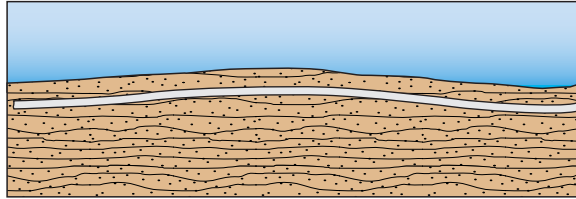

C) UPHEAVAL

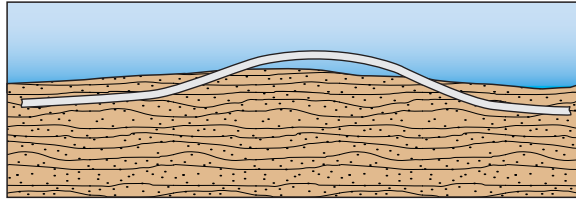

THAW SETTLEMENT LOADING

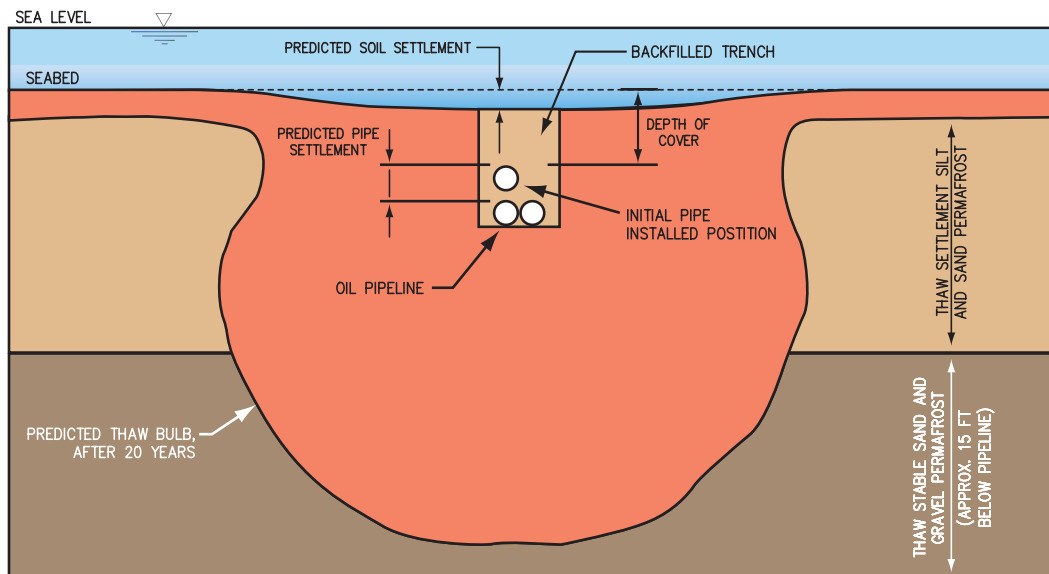

FIGURE 4
UPHEAVAL BUCKLING AND THAW SETTLEMENT

- **Strudel Sour:** Scouring of the seafloor by water draining through “strudel” holes in the ice. This occurs in spring when rivers thaw before the nearshore ice sheet, and river water flows out over the ice. Strudel scour can expose the pipeline and erode material under the pipe, causing strain on the pipeline (Figure 3).

Another design consideration is the **backfill thickness**. This is important where the difference between the ambient temperature and pressure during the installation and pipeline operation is great. This pipe expansion due to temperature differences — in combination with the pipe wall thickness, backfill soil properties, and the levelness of the trench — affects the pipe vertical stability due to **upheaval buckling** (Figure 3). When a buried steel pipeline operates at a temperature and pressure higher than at installation, it will try to expand lengthwise, and at individual high points along the pipe, the pipe exerts an upward force into the soil cover. If the upward force exceeds the resistance of the soil cover, the pipeline stiffness, and the pipeline weight, the pipeline will move up and may become exposed on the seafloor. This phenomenon is known as upheaval buckling.

Another external pipe load directly caused by backfill thickness is the result of **thaw settlement** (Figure 4). In nearshore shallow waters of Foggy Island Bay, the soil under the pipeline could contain permafrost. Because the pipeline will be warm, a “thaw bulb” will develop around the pipe. If the frozen soil has a high ice content, this thawing can cause the soil to settle, and the soil cover on the pipeline loads it, placing strain on the pipeline. Deeper pipeline trenching can increase the backfill thickness and thus leads to an increased overburden load during thaw settlement, but it also can reduce the amount of settlement. However, deeper pipeline trenching protects the pipeline from strudel scour and ice gouging.

Finally, the pipeline must avoid excessive internal and external corrosion over the project life, and external corrosion control is required for each pipeline alternatives.

2. INSTALLATION METHODS

Possible methods for excavating the trench and installing the pipeline were reviewed. Trenching methods include conventional excavation with dredging, plowing, jetting, and mechanical trenching. Installation methods include use of lay vessels, reel vessels, tow or pull methods, and installation in winter through an ice slot. The possibility of using directional drilling from shore was also examined, but too many technical difficulties were identified. Completing one hole and installing a pipeline by directional drilling is a relatively complex undertaking, but is nevertheless technically feasible. However, a series of directional drilling operations would magnify the complexity of the installation, would likely require two construction seasons, and would also require the design of protection of the seabed connections between drilled sections.

Only one hydrocarbon pipeline has been built in an arctic offshore environment, and it was installed using a bottom-pull method for the bundle installation and a plow for trenching. The project was installed off Melville Island in the Canadian High Arctic between 1976 and 1979. The Drake Field experience shows that a high level of quality assurance was needed during

construction. However, it is important that the pipeline was only 4,000 feet long (12% of the proposed pipeline length), but the make-up of the pipe bundle lasted 4.5 months, not including pipeline installation. Thus, considerably more time was needed than for a more conventional pipeline configuration.

The different configurations of the alternatives have different implications on the construction and installation program. For example, the single wall pipeline would be buried in a deeper trench, whereas the pipe-in-pipe alternative requires extensive make-up assembly and more equipment. On balance, the pipe-in-pipe and pipe-in-HDPE alternatives are much more difficult to construct than the single wall or flexible pipe alternatives. Therefore, the risk will be much higher that the construction work will not be completed in a single season.

The preferred construction method is from an ice platform in winter using conventional excavation equipment and off-ice installation techniques. Reasons include the following:

- This method uses conventional, proven equipment available locally.
- Ice-strengthening and ice-cutting techniques are well understood.
- A through-ice test trenching program has been carried out on the North Slope to prove the feasibility.
- Other construction methods would require that significant equipment be mobilized to the North Slope, which may require the equipment to over-winter (i.e., barges).
- Open-water construction equipment is not designed for these shallow water depths.
- A skilled labor force is available.
- Alaskan content in the project is maximized.

3. COST AND SCHEDULE

Cost estimates range from \$31 million for the single-wall steel pipe to \$61 million for the steel pipe-in-pipe, including the base case cost plus a contingency value. The contingency value is estimated based on the confidence associated with meeting the proposed schedule. For the pipe-in-pipe and the pipe-in-HDPE alternatives, there is a high likelihood that an additional construction season will be required to complete these more complex construction programs. Therefore, the contingency includes a portion of the additional season construction costs.

4. OPERATIONS AND MAINTENANCE CONCERNS

The main difference in maintenance of the pipeline systems is that monitoring cannot be accomplished in all structural components of some alternatives. It is not presently feasible to monitor the integrity of the outer jacket pipe of the pipe-in-pipe, pipe-in-HDPE, and flexible pipe alternatives. Post-failure monitoring could be achieved for these two systems using the annular leak detection system to detect the presence of water and oil. However, no preventive monitoring of the outer jacket pipe can be performed for these systems.

**TABLE 2
SUMMARY COMPARISON OF ALTERNATIVES**

Description	Pipeline Alternative			
	Single Wall	Pipe-in-Pipe	Pipe-in-HDPE	Flexible Pipe
Configuration				
Depth of Cover (feet)	7	5	6	5
Duration of Trenching (days)	33	26	30	24
Gravel Backfill (yds ³) [Does not include 50% contingency]	9,000 (in gravel mats)	0	10,000 (30 yds ³ every 100 feet)	10,000 (30 yds ³ every 100 feet)
Pipe Specific Gravity	1.6	2.2	1.2	1.1
Number of Welds/ Connections	808 welds; 11 are tie-ins	1616 welds; 66 are tie-ins	808 welds, 808 fusions; 66 connections are tie-ins	13 connections; 11 tie-ins
Cost				
Budgetary Cost (\$ millions)	31	61	44	37
Relative Cost (%)	100	195	140	120
Schedule				
Estimated Schedule Basis	Single winter season	Single winter season	Single winter season	Single winter season
Likelihood of Additional Season for Construction (%)	10	80	60	10
Installation				
Ice Thickness (feet)	8.5	10.5	8.5	8.5
Relative Quantity of Construction Equipment per Season (%)	100	120	115	90
Considerations	Identification of vertical pipeline profiles that do not meet the design criteria	<ul style="list-style-type: none"> • Pipe-in-pipe assembly logistics • Assurance of dryness of 12-in. pipe prior to pipe-in-pipe assembly • Achieving pull-in of 12-in. to outer jacket • Handling pipe-in-pipe system (210 lb/ft) and large stiffness • Thicker ice platform needed 	<ul style="list-style-type: none"> • Assurance of dryness of 12-in. pipe prior to pipe-in-HDPE assembly • Executing pipe-in-HDPE assembly • Maintaining pipeline stability in trench • First application of the HDPE of this type 	<ul style="list-style-type: none"> • Logistics for transporting and handling heavy reels • Maintaining pipeline stability in trench
Operation & Maintenance Concerns	Conventional operations	Monitoring of outer pipe integrity	Monitoring of outer pipe integrity	Monitoring of flexible cross-section
Leak Detection				
Standard Mass Balance and Pressure Point Analysis Supplemental System	Yes LEOS	Yes Annulus monitoring	Yes Annulus monitoring	Yes Annulus monitoring

Cleanup strategies for a potential spill would be similar for any of the pipeline alternatives. The manpower and capabilities would be in place to successfully monitor, control, and clean up any spill at any time of the year, however remote the possibility. There is a risk of a secondary spill volume during repair of alternatives with an annulus; this risk must be considered during the development of detailed repair procedures.

- For all pipeline alternatives, there are periods (breakup and freeze-up) when a repair could not be carried out.
- For alternatives with an annulus, all moisture and oil would need to be removed from the annulus during repair. Any moisture that remains in the annulus could potentially cause corrosion of the inner or outer pipe. Any oil that remained in the annulus could potentially leak out at a later time if the integrity of outer pipe, jacket, or sheath was compromised.
- Not all repairs are able to return some pipeline systems to the same integrity level as originally constructed.

For all alternatives except the single wall pipe, repair is difficult, if not prohibitive. The issues include pipe retrieval, repair splicing and annulus purging (for pipe-in-pipe and pipe-in-HDPE), and long-term pipe integrity.

5. LEAK DETECTION SYSTEMS

Conventional state-of-the-art leak detection for any of the pipeline alternatives can be achieved using two independent systems. Mass balance line pack compensation (MBLPC) and pressure point analysis (PPA) can be applied to any of the alternatives and combined have an expected threshold of 0.15% of the volumetric flow. Leaks beneath this threshold would be detected using a supplemental system such as LEOS, which is a commercially available system installed alongside the pipe in the trench. LEOS is able to detect leaks smaller than the 0.15% threshold and is currently considered the best available technology. Annulus monitoring has been recommended as a supplemental leak detection system for those configurations with an annulus and would be expected to provide a threshold of detection as good as LEOS. However, if desired, LEOS could be applied to any of the pipeline alternative systems.

The offshore oil pipeline would be continuously monitored, and all system parameters would be relayed back as electronic signals to a standalone computer. The system parameters would be compared to predetermined alarm set-points and calculated values.

6. RISK ASSESSMENT

In order to determine the probability of the pipeline being damaged from external forces, a risk assessment was performed which evaluated the likelihood of four categories of damage to each alternative:

1. Displaced pipeline with no leak
2. Cross-section buckle in the pipe with no leak

3. Small or medium leak (125 bbl to environment)
4. Large leak or rupture (1,567 bbl to environment)

Figure 5 identifies the initiating events and causes of a failure.

The main conclusion of the risk analysis is that the risk, expressed in barrels of oil spilled into the environment, is negligible for all alternatives. The safeguards in the single wall pipeline alternative (i.e., depth of cover; trench backfill material and procedures; pipe wall thickness; cathodic protection system, anodes and coating; routine geometry pig inspections; and leak detection systems) provide a total system reliability that minimizes the risk of environmental oil spills. The single wall pipeline system is also relatively easier to repair.

The double wall systems are the second best. Their risk of oil spills is more than an order of magnitude greater than the single wall pipe, but the risk is still very small and acceptable and can be further reduced with the increased cost of greater depth of cover. Given the higher risk, cost, and the difficulty of repair, these systems are less suitable than the single wall system. The flexible pipe system has a risk of oil spill nearly 100 times greater than the single wall pipeline. This risk is still relatively low and can be decreased by increasing its burial depth. However, even if the depth of cover is increased, this alternative is unattractive because of the extra difficulties for installation with heavy reels and the possible repair of 2,800-foot segments. This system is not recommended for this application.

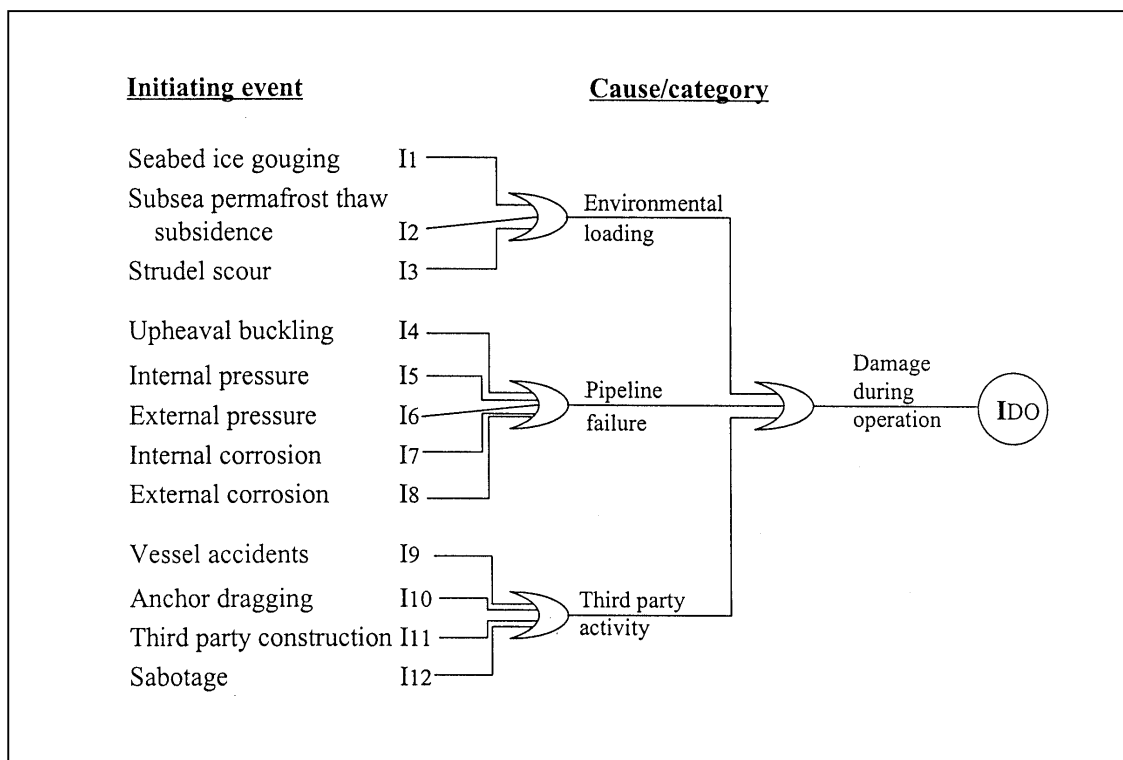

**FIGURE 5
POTENTIAL DAMAGE-CAUSING EVENTS EVALUATED IN RISK ASSESSMENT**

The shallower depth of cover for the pipe-in-pipe system is the main factor increasing the risk of oil spilled into the environment. To make this risk similar to that of the single wall pipe, the depth of cover needs to be increased to 7 feet — at an increased cost of about \$10 million.

**TABLE 3
RISK OF OIL SPILLED INTO ENVIRONMENT FOR DIFFERENT ALTERNATIVES**

Alternative	Single Wall	Pipe-In-Pipe	Pipe-In-HDPE	Flexible Pipe
Risk (bbls)	0.0016	0.028	0.014	0.14
Relative risk	1	18	9	88

“Risk” = frequency x consequences, in units of the consequence

Example: Single wall risk = $(1 \times 10^{-5}) \times 125 \text{ bbls} + (2 \times 10^{-7}) \times 1,567 = 1.6 \times 10^{-3} \text{ bbls}$

“Relative risk” = system risk divide single wall pipe system risk

7. CONCLUSIONS AND OBSERVATIONS

The evaluation of pipeline alternatives for BP Exploration’s Liberty Development concluded that any of the alternatives can be designed structurally to meet the functional requirement of transporting oil and resisting forces imposed by environmental factors. However, the single wall steel pipeline offers the most advantages over the other alternatives by providing the lowest risk of a spill to the environment.

The primary aim of pipeline design is to engineer a pipe or conduit that will transport a product from one location to another without failing from internal or external forces. A significant part of the design effort is to economically optimize the pipe diameter, wall thickness, and material strength, while still safely achieving the design throughput. In the case of steel pipe materials, close attention is paid to protecting the pipe from corrosion. Internal corrosion may be due to the product transported in the line or the unintentional introduction of a corrosive substance at some point during pipeline operation. External corrosion may be due to the surrounding soil or water if the line is buried or installed under water. Generally, steps are always taken to limit corrosion by application of an external corrosion coating, installation of cathodic protection, and if required, the injection of corrosion inhibitors into the product stream during pumping or compression.

Pipeline design codes and standards do not suggest a requirement to provide an outside pipe jacket whose sole purpose is to contain any loss of contents of the pipeline it surrounds. The conditions that might give rise to a loss of product from the inner pipe would also affect the outer pipe. Specific conditions such as the corrosiveness of the transported product are always considered in the design. Pipe-in-pipe systems are used in some cases, but the outer pipe does not serve as a back-up in the event that something has been omitted in the original design effort. Their prime function is to satisfy installation economics or another design condition, such as to thermally insulate or facilitate field installation.

The pipe-in-pipe and pipe-in-HDPE alternatives are more expensive and would most likely require an additional construction season compared to the single wall and flexible alternatives. Monitoring of the pipeline's integrity during operation is required to allow for preventive maintenance. The single wall pipe alternative is the only solution that allows all the design aspects to be monitored during operation — a very important consideration for a buried subsea pipeline.

**Response to MMS, Agency and Stress Engineering Comments –
Liberty Pipeline System Alternatives (prepared by INTEC)**

This appendix was published as part of the Liberty Development and Production Plan (DPP) Draft Environmental Impact Statement (EIS) and was not revised for the Final EIS. The reader is referred to this appendix in the Draft EIS. This appendix is also available on the CD-ROM (MMS 2002-019 CD) and on the Internet (<http://www.mms.gov/alaska/cproject/liberty>).

**RESPONSE TO MMS, AGENCY,
AND STRESS ENGINEERING COMMENTS
LIBERTY PIPELINE SYSTEM ALTERNATIVES**

**LIBERTY DEVELOPMENT PROJECT
CONCEPTUAL ENGINEERING**

PREPARED FOR

**BP EXPLORATION (ALASKA), INC.
ANCHORAGE, ALASKA**

**INTEC PROJECT NO. H-0851.02
PROJECT STUDY PS19**

APRIL 2000

MMS Letter of March 17th, 2000

Request #1: We request BPXA provide a thorough explanation as to why different depths of cover were selected for the various pipeline systems.

Response #1: All pipeline systems have been conceptually evaluated against the most pressing environmental loadings (ice gouging and upheaval buckling), with the 7-foot of depth of cover as a basis. Based on this evaluation, it appeared some of the pipeline systems could safely have the depth of cover reduced and still satisfy upheaval buckling and other loading requirements. The report philosophy was to treat each alternative design as a potential actual project that might be built. Reducing cover reduces construction time, reduces construction risk, reduces cost, makes repair easier if necessary, and in some cases reduces pipeline loading (e.g. in some cases of permafrost thaw settlement). In practice, a designer seeks to reduce these aspects if possible and, thus, the necessary depth of cover has been assessed for each option. If depth of cover or wall thickness, for example, are not determined based on performance requirements, there is no apparent basis for objectively defining cases for subsequent environmental risk assessment. In other words, as would be the case in actual design practice, the analysis sought to optimize design factors to arrive at an overall optimized design. This has resulted in a reduced cover depth for the other alternatives. Completion of this analysis would not preclude a subsequent decision to bury any alternative pipeline deeper.

Thus, an Addendum to the Pipeline System Alternatives report has been generated (Attachment A) which looks at a constant burial depth for all alternatives. This Addendum also addresses single season construction for the pipe-in-pipe and pipe-in-HDPE alternatives.

Request #2: We request BPXA address the apparent disregard of the benefits of the PIP and PIH to provide secondary product containment.

Response #2: The ability of the outer pipe to contain small leaks of the inner pipe has not been discounted. All four pipeline alternatives are designed, at a conceptual level, to safely transport oil from Liberty Island to shore. Two of the alternatives, pipe-in-pipe, and pipe-in-HDPE have the ability to contain leaks of the carrier (or inner) pipe in certain conditions. These conditions are such that the outer pipe remains integral while the inner pipe experiences a leak. The corresponding failure mode is then corrosion of the inner pipe. This has been accounted for, since the frequency of corrosion failure does not translate into an oil spill into the environment for the double-walled pipe alternatives. See and compare Tables 5-14 and 9-2 of the Pipeline System Alternatives report.

More specifically, Damage Category 3 in Table 5-14 has been split into 3 different types as described in the footnotes associated with that table. In summary, due to the pipe-in-pipe redundancy, the frequency of corrosion damage of the inner or outer pipe does not translate into a spill frequency. In other words, Category 3 damage frequency in Table 5-14 adds up to 3×10^{-4} ; however, in Table 9-2, the corresponding entry for the Category 3 for the pipe-in-pipe is only 1×10^{-4} since the consequence of corrosion damage does not imply immediate spill to the environment.

In the Addendum to the Pipeline System Alternatives report, further narrative has been added addressing the potential benefits of secondary containment using pipe-in-pipe and pipe-in-HDPE systems and Table 9-2 of the original report has been revisited.

Request #3: We request BPXA address single season construction for the PIP and PIH alternatives.

Response #3: The implications of a single season construction for the pipe-in-pipe and pipe-in-HDPE are presented in the Addendum to the Pipeline System Alternatives report. Recent North Slope construction experience with the Northstar pipelines indicates that the pipeline was completed approximately 2 weeks prior to an anticipated end of construction cut-off date for Liberty. Given the added complexity of a pipe-in-pipe or pipe-in-HDPE system, engineering judgement suggests that it would have been very difficult to complete such a system during this year's construction window. Therefore, even though the Addendum proposes a single season scenario, there is still significant risk of not completing either of these two alternative designs in a single season.

Stress Engineering Services Draft Final Report of March, 2000

The response to the comments, observations and issues presented by Stress Engineering Services are presented in Attachment B.

MMS Comments on Pipeline System Alternatives – Liberty Development Project Conceptual Engineering Report

The response to the comments made by the MMS are presented in Attachment C.

Fish and Wildlife Service Letter of December 3rd, 1999

Issue #1, Secondary Containment - See BPXA's response to Request #2 of the MMS letter of March 17th, 2000 (above). In the Addendum to the Pipeline System Alternatives report (Attachment A), further narrative has been added addressing secondary containment using pipe-in-pipe and pipe-in-HDPE systems.

Issue #2, Leak Detection - As part of the US Army Corps of Engineer stipulations for Northstar, BPXA agreed to design, construct, operate and maintain a prototype leak detection system that would be installed with the offshore pipelines. This system would have the ability to detect an oil spill beneath current threshold detection limits (from PPA and MBLPC). The system design had to be submitted and approved by the Corps prior to initiating pipeline trenching. INTEC Engineering investigated a number of supplemental leak detection strategies for Northstar and recommended the use of the LEOS system as it was considered the best available technology. This system is currently being installed with the Northstar pipelines.

It should be noted that although the LEOS system is considered the best available technology, by the time the Liberty pipeline is ready to be installed, another system may be identified that would be considered the best available technology. This could partially result from lessons to be learned from the Northstar installation and operation.

Issue #3, Pipe-in-Pipe Design - Pipeline system alternatives evaluated in the INTEC report were the result of MMS and agency input at several meetings in 1999. Based on these meetings, several pipe-in-pipe options were carried to the conceptual design selection process where the preferred alternative was then carried forward for further analysis. This was agreed to limit the number of options to be analyzed.

As pointed out in page 5-8 of the Pipeline System Alternatives report, the calculations assumed that the inner and outer pipe had the same radius of curvature. In other words, the inner and outer pipe acted as a unit with a stiffness equal to the sum of the individual pipeline's stiffness. If the inner and outer pipe wall thickness was reduced, the stiffness of each individual pipe would be reduced and, therefore, the overall system stiffness is reduced. For a given load condition, pipeline strains would increase with a decrease in stiffness.

While assuming that both pipes have the same curvature is a valid approximation of the average structural behavior under bending at the conceptual level, the loads between the outer pipe and the inner pipe would actually be transferred at discrete points along the pipeline length where the spacers are located. The localized load transfer at spacers would magnify pipe bending strain at

these locations. This localized strain increase would need to be assessed in detailed design and the spacers designed accordingly.

Issue # 4, Single Season Construction - The implications of a single season construction for the pipe-in-pipe and pipe-in-HDPE are presented in the Addendum to the Pipeline System Alternatives report (Attachment A). However, even though the Addendum proposes a single season scenario, there is still a schedule risk associated with completing the construction of either of these two alternative designs in a single season. In fact, there is even a risk that a single wall steel pipeline could not be completed in a single season.

Issue #5, Conclusions - See BPXA's response to Request #2 of the MMS letter of March 17th, 2000 (above). In the Addendum to the Pipeline System Alternatives report (Attachment A), further narrative has been added addressing secondary containment using a pipe-in-pipe or pipe-in-HDPE alternative.

Department of the Army Letter of December 23rd, 1999

An Addendum to the Pipeline System Alternatives report is attached (Attachment A). This Addendum presents an analysis of a constant burial depth for all alternatives and addresses single season construction for the pipe-in-pipe and pipe-in-HDPE alternatives. Further narrative has also been added addressing secondary containment using a pipe-in-pipe or pipe-in-HDPE alternative. Specific to concerns outlined in the DOA letter:

Pipeline Performance Standards (Paragraph 1, Page 2) - The pipeline performance standards of minimizing the likelihood of oil entering the environment, and facilitating leak detection and containment are further addressed in the attached Addendum (Attachment C).

Secondary Containment (Paragraph 2, Page 2) - Please see the response to Request #2 of the MMS letter of March 17th 2000, and response to Issue # 1 of the Fish and Wildlife Service letter of Dec. 3rd 1999. Further narrative has been included in the Addendum to the original report addressing secondary containment using a pipe-in-pipe or pipe-in-HDPE alternative.

Pipe-in-Pipe Design (Paragraph 2, Page 2) - Please see the response to Issue # 3 of the Fish and Wildlife Service letter of Dec. 3rd 1999.

Leak Detection (Paragraph 2, Page 2) - Please see the response to Issue # 2 of the Fish and Wildlife Service letter of Dec. 3rd 1999. Additional narrative on leak detection in the annulus of

the pipe-in-pipe and pipe-in-HDPE alternatives is provided in the secondary containment section of the attached Addendum.

Construction Season (Paragraph 2, Page 2) - Please see the Response to Request #3 of the MMS letter of March 17th 2000, and response to Issue # 4 of the Fish and Wildlife Service letter of Dec. 3rd 1999. Further information has been included in the Addendum regarding a single season construction for the pipe-in-pipe and pipe-in-HDPE alternatives.

Department of the Army Letter of December 30th, 1999

Again, the Addendum to the Pipeline System Alternatives report (Attachment A) provides further narrative addressing secondary containment using a pipe-in-pipe or pipe-in-HDPE alternative, including leak detection in the annulus. Specific to concerns outlined in the DOA letter:

Cathodic Protection (Paragraph 3, Page 1) – The use of cathodic coatings such as thermal sprayed aluminum or discrete anodes for the inner pipeline has not been investigated at this conceptual level. Stress Engineering, in their evaluation of the INTEC report, has suggested the use of such protection but points out that the cathodic protection of the inner pipe could not be monitored. As such, it could not be verified to be effective. Providing cathodic protection between closely spaced metal components or on metal shielded by plastic is generally more difficult than on the exterior of a single wall pipeline. The conceptual evaluation addressed maintaining an inert environment of dry air, nitrogen, or a vacuum in the pipe-in-pipe or pipe-in-HDPE annulus to limit the potential for corrosion.

It is pointed out in the Stress Engineering report (p. 18) that CFR 49 195.242 requires, "... a test procedure that will be used to evaluate adequacy of the CP system" and "The code requirement will not be waived and therefore it makes the design of the CP system the critical issue". Stress Engineering notes, "... the cathodic protection of the inner pipe could not be monitored".

Leak Detection in the Annulus (Paragraph 3, Page 1) – The attached Addendum to the original report further addresses leak detection in the annulus of the pipe-in-pipe and pipe-in-HDPE system alternatives.

Leak detection within a pressure-tight, continuous annulus (e.g. pipe-in-pipe without intermediate bulkheads) is in fact considered in the report as a highly reliable early warning system for leaks (e.g. page 5-32). Details on annulus pressure monitoring procedures, gas sampling, or fiber optic sensor systems would be determined during preliminary/detailed pipeline design. These systems would be expected to be significantly more reliable than ice borehole sampling and maybe slightly more sensitive or reliable than an external LEOS system.

Leak Detection Technology (Paragraph 3, Page 1) – As stated on page 3-37 of the INTEC report, a wide range of leak sensors and leak detection systems was researched (by INTEC) for the Northstar project. Details were not provided in the Liberty Pipeline System Alternatives report but are contained in the document, “Northstar Development Project, Prototype Leak Detection System, Design Interim Report” (INTEC Engineering, 1999). Over 30 sensing technologies were considered of the following generic sensor types:

- Chemical (Subsea)
- Electrical (Subsea)
- Optical Fiber
- Well Logging Technology
- Acoustic
- Electromagnetic
- Soil Resistivity / Capacitance

This study came about as the result of the US Army Corps of Engineer stipulations for Northstar. BPXA agreed to design, construct, operate and maintain a prototype leak detection system that would be installed with the offshore pipelines. This system would have the ability to detect an oil spill beneath current threshold detection limits (from PPA and MBLPC). The system design had to be submitted and approved by the Corps prior to initiating pipeline trenching. INTEC Engineering investigated a number of supplemental leak detection strategies for Northstar and recommended the use of the LEOS system as it was considered the best available technology. This system is currently being installed with the Northstar pipelines.

It should be noted that although the LEOS system is considered the best available technology, by the time the Liberty pipeline is ready to be installed, another system may be identified that would be considered the best available technology. This could partially result from lessons to be learned from the Northstar installation and operation.

Risk Assessment Accounting for Secondary Containment (Paragraph 1, Page 2) – The risk assessment did account for the benefit of secondary containment of the pipe-in-pipe system. Please refer to the response to Request #2 of the MMS letter of March 17th and the attached Addendum.

Risk Assessment Accounting for Increased Structural Integrity (Paragraph 1, Page 2) – The increased structural integrity of the pipe-in-pipe system has been accounted for in the operational

failure assessment (for example, see Subsections 5.9.1.2 or 5.9.1.3. However, the increased structural integrity is coupled with the fact that the depth of cover is less than that for a single wall steel pipeline. This results from the increased bending stiffness and reduced potential for upheaval buckling of a pipe-in-pipe system. The attached Addendum addresses a constant burial depth for all alternatives.

Probability of Spill (Paragraph 1, Page 2) - The failure assessment sections of the report provide narrative on and tables indicating the number of event occurrences during the project lifetime. The probability of each category of leak is presented for the different environmental loadings, failure mechanisms, and third party activities. The sections indicate which events would not result in a spill to the environment (e.g. corrosion of the inner pipe only of a pipe-in-pipe system). See also Response #2 to the MMS letter of March 17th, 2000.

Secondary Containment (Paragraph 1, Page 2) – The Pipeline System Alternatives report has considered the effect of a pipe-in-pipe system when looking at pipeline system failure due to ice gouging. It is expected that if an ice gouge event occurred and loaded the system to such an extent that the carrier pipe failed, that event would also cause the outer pipe to fail. Secondary containment is only effective when the inner pipe fails and the outer doesn't – such as when there is corrosion of the inner pipe only.

Expected Oil Leak (Paragraph 3, Page 2) – The rationale behind a leak rate of 97.5 barrels of oil per day is presented in Subsection 3.8.4.1. The 125 barrels loss prior to detection is the result of an assumed leak detection reading every 24 hours; $97.5 + 0.4 + 27 = 124.9 \approx 125$ barrels. If the final selection of a leak detection system on a pipe-in-pipe or pipe-in-HDPE system allows a shorter leak detection reading time, then this volume may be reduced. Calculations have also been carried out in Section 3.8.4.1 to arrive at the 27 barrels due to expansion of the oil in the overland as well as the offshore segment of the pipeline.

Detection Response Time Along the Pipeline Route (Paragraph 3, Page 2) – No site-specific calculations have been conducted to determine the LEOS response time along the Liberty Pipeline route. However, LEOS is a commercially available leak detection system. It has been used onshore and for river crossings for 21 years. The manufacturer estimates that the system would be capable of detecting hydrocarbon concentrations resulting from leak rates as low as 0.3 barrels of oil per day for Northstar. The response of the system would be expected to be similar for Liberty. The manufacturer has conducted a number of documented tests in the field and the laboratory on the performance of the system in different soil conditions and water depths to 400 feet. The manufacturer has estimated that a leak occurring farthest from the sensor tube

(i.e. 180° opposite on the pipe circumference) would still result in the diffusion layer contacting the sensor tube within 4 to 6 hours.

125-Barrel Oil Leak Applied to Pipe-in-Pipe (Paragraph 3, Page 2) – The medium leak volume of 125 barrels also applies to the pipe-in-pipe system. But, as previously noted, this volume will vary with the specific system detection time. Soil conditions around any of the pipeline alternatives will vary from alternative to alternative and will also vary along the line. The migration path of the oil outside of the pipeline system will depend on these soil conditions and will change somewhat as a result. However, as the hydrocarbon molecules diffuse through the water-soil matrix, the system response is not significantly affected by the tube position relative to the actual leak location on the pipe circumference (and therefore ~~visible migration pattern of the~~ oil). As part of the validation process of the LEOS system for Northstar, numerical simulations of oil migrations in submerged soils saturated with seawater were performed. (“Northstar Development Project, Prototype Leak Detection System, Design Interim Report”, INTEC Engineering, Inc., July 1999). The effect of leak rate, soil type, and water depth were investigated. Results indicated the oil would migrate into the surrounding oil and encapsulate the entire pipe circumference, even when the leak is initiated at the outboard side of the pipe.

In the attached Addendum to the Pipeline System Alternatives report, further narrative has been added addressing the potential benefits of secondary containment using pipe-in-pipe and pipe-in-HDPE systems. Other factors which may be investigated in a detailed pipe-in-pipe leak assessment may be the relative time between inner/outer pipe leakage and potential oil water flow within the annulus.

Early Detection (Paragraph 3, Page 2) – It is correct that any alternative which could limit the quantity of release such as by early detection would have less damage. The fact that a system has an annulus, does not necessarily mean that detection of the leak will be any earlier. It does mean that some leaks could be contained and detected. In the attached Addendum to the Pipeline System Alternatives Report, further discussion is provided on secondary containment and annular leak detection.

Independent Risk Evaluation for the Liberty Pipeline: Executive Summary (Fleet, 2000)

This appendix was published as part of the Liberty Development and Production Plan (DPP) Draft Environmental Impact Statement (EIS) and was not revised for the Final EIS. The reader is referred to this appendix in the Draft EIS. This appendix is also available on the CD-ROM (MMS 2002-019 CD) and on the Internet (<http://www.mms.gov/alaska/cproject/liberty>).

INDEPENDENT RISK
EVALUATION FOR
THE LIBERTY PIPELINE

G. Comfort
A. Dinovitzer
R. Lazor

Submitted to:
Attn: D. Hinnah
Minerals Management Service
949 East 36 th Avenue, Suite 308
Anchorage, Alaska
99508-4363

Submitted by:
Fleet Technology Limited
311 Legget Drive
Kanata, Ontario
K2K 1Z8

September, 2000

ACKNOWLEDGEMENTS

Dennis Hinnah of the Minerals Management Service was the Contracting Office Technical Representative (COTR). He is thanked for providing guidance and for expediting numerous reference materials to the project team.

The Geological Survey of Canada (GSC) provided very valuable assistance to the project. Dr. I. Konuk is thanked for his wide-ranging technical guidance that was provided during many discussions.

As well, the GSC had the foresight to undertake a detailed structural analysis of the behaviour of a single steel pipe when subjected to the combination of soil displacements induced by ice gouging, pipeline temperature increases, and the effects of pipeline internal pressure. Detailed analyses were carried out by Dr. Abdellfettah Fredj under the direction of Dr. I. Konuk. They investigated different structural modelling approaches, and they identified key trends and parameters.

This basic work was very helpful for this project, and the GSC used their model to analyse several cases of direct interest to this project. Their results were used directly as an input to this risk evaluation.

DISCLAIMER

The opinions, findings, conclusions, or recommendations expressed in this report or product are those of Fleet Technology Limited and do not necessarily reflect the views of the U.S. Department of the Interior.

EXECUTIVE SUMMARY

Conclusions

Basis for Conclusions - A detailed analysis has been carried out to determine the risk for each of the concept pipeline designs produced by Intec, 1999; 2000. Risk (which is the product of the event probabilities and event consequences) was defined in terms of the volume of oil expected to be released over the 20-year life of the Liberty Pipeline.

The study investigated and quantified the following:

- (a) the hazards for the pipeline. The hazards investigated included ice gouging, strudel scour, permafrost thaw subsidence, thermal loads leading to upheaval buckling, corrosion, operational failures, and third party activities;
- (b) the response of the pipeline to these hazards; and
- (c) the consequences of pipeline failure for each hazard, taking into account the monitoring systems that will be used. Consequences were evaluated for three types of pipeline failure: (i) rupture, (ii) flow through the maximum stable crack, and (iii) flow through pinholes (termed seepage).

Review Process - A draft final report was submitted by FTL in July, 2000, which was extensively reviewed. The comments received, and FTL's direct reply to them, are provided in Appendices F and G, respectively. The main text of the report was revised as well in response to the comments received.

Approach - Risks due to ice gouging and strudel scour were determined by establishing and quantifying event trees. Risks due to permafrost thaw subsidence, thermal loads leading to upheaval buckling, corrosion, operational failures, and third party activities were evaluated by analyzing failure statistics for pipelines in other regions.

Summary Results - The risk was evaluated first for a base case that represented FTL's best estimate for all input parameters. The risk for the base case for each pipeline design is summarized in Table 1.

Table 1: Total Risk¹ for the Base Case for Each Pipeline Design

Single Steel Pipe ²	Steel Pipe-in-Pipe ²	Pipe-in-HDPE ²	Flexible Pipe ²
28 ; 28	8 ; 13	24 ; 24	29 ; 28

Notes:

1. All risk values are in bbls.
2. The risk values are for the pipe designs produced by Intec, 1999; 2000, respectively.

Most Significant Hazards - Oil releases resulting from operational failures were found to pose the vast majority (about 95%) of the total risk for the single steel pipe, the pipe-in-HDPE, and the flexible pipe designs.

The most significant risks for the steel pipe-in-pipe design were oil spilled as a result of operational failures that breach both the inner and outer pipes, and oil spilled during repair operations.

Comparison of Pipe Designs - For the base case, the steel pipe-in-pipe design was found to have about 30 to 50 % less risk than the single steel pipe, the pipe-in-HDPE, and the flexible pipe designs. This was primarily due to the secondary containment provided by the steel pipe-in-pipe design.

The single steel pipe, the pipe-in-HDPE, and the flexible pipe designs all had comparable risk within the accuracy of the analyses conducted.

Sensitivity Analyses - An extensive sensitivity analysis was conducted. The following factors had the greatest effect on the total risk for the Liberty Pipeline:

- (a) the water depth at which the hazard occurs;

- (b) the performance of the monitoring systems;
- (c) the assumptions made regarding secondary containment;
- (d) the occurrence frequency, and hence, risk, for oil releases due to operational failures and third party activities; and
- (e) the assumptions made regarding the pipeline failure mode.

Maximum Expected Risk for Each Pipeline Design – This was evaluated using a simplified approach that accounted for the risk augmentation factors listed above. The maximum expected risk was about 60% more than the base case values for the single steel pipe, the pipe-in-HDPE, and the flexible pipe designs (Table 2). The maximum risk for the steel pipe-in-pipe design was about 2 to 3 times more than the base case value (i.e., 24 bbls vs 8-13 bbls, respectively).

Thus, the differences between the four designs reduced somewhat as a result of the sensitivity analyses. Nevertheless, the relative rankings of the four pipe designs was unchanged compared to the base case (Table 1) as follows:

- (a) the steel pipe-in-pipe design had the least risk, and;
- (b) the single steel pipe, the pipe-in-HDPE, and the flexible pipe all had more risk than the steel pipe-in-pipe. Furthermore, these three designs had equal risk within the accuracy of the analyses.

Table 2: Total Expected Maximum Risk¹ for Each Pipeline Design

Single Steel Pipe ²	Steel Pipe-in-Pipe ²	Pipe-in-HDPE ²	Flexible Pipe ²
45	24	44	45

Notes:

- 1. All risk values are in bbls.
- 2. The risk values are the maximums for the pipe designs produced by Intec, 1999 ; 2000, respectively.

Probability of a Spill Larger Than 1000 Barrels – The steel pipe-in-pipe design was found to have the lowest probability of a large spill (Table 3). The single steel pipe, the pipe-in-HDPE, and the flexible pipe designs were found to be equivalent within the accuracy of the analyses conducted.

Table 3: Total Probability of a Spill Exceeding 1000 Barrels¹

Single Steel Pipe ²	Steel Pipe-in-Pipe ²	Pipe-in-HDPE ²	Flexible Pipe ²
0.0138 ; 0.0138	0.00158 ; 0.00234	0.0138 ; 0.0138	0.0138 ; 0.0138

Notes:

- 1. All values are for the base case.
- 2. The listed probabilities are for the pipe designs produced by Intec, 1999 ; 2000, respectively.

Uncertainties - The most important uncertainties are considered to be:

- (a) the significance of the risk variations determined for the four pipeline designs. This issue was not investigated as it was beyond the Terms of Reference or scope of work. However, because this is considered to be the most significant uncertainty affecting the interpretation of the results, this would be a useful follow-on investigation.
- (b) the information available to assess oil releases arising from operational failures is very limited as pipelines have not yet been operated offshore in the Arctic. As a result, the study was forced to rely on failure statistics from other regions to evaluate the risk due to this hazard.

The determination of the risk due to operational failures was also hindered by the fact that the Liberty Pipeline has only been developed to the concept design stage. This risk will be affected and controlled by issues such as operator training schedules, maintenance plans, surveillance, and monitoring which have not yet been finalized.

- (c) the assumptions necessary to evaluate the secondary containment provided by the steel pipe-in-pipe and the pipe-in-HDPE designs.
- (d) the information available to define the material properties and behaviour for the pipe-in-HDPE and flexible pipe designs.

Recommendations - The study results as well as the key uncertainties identified suggest logical areas for further study, or for the future application of resources as follows:

- (a) the significance of the risk variations determined for the four pipeline designs should be investigated.
- (b) operational failures were found to be the most significant hazard. Two actions are recommended:
 - (i) this finding should be investigated further. In particular, this finding should be re-examined after key issues such as operator training, surveillance, and monitoring plans have been developed further for the Liberty Pipeline.
 - (ii) future efforts aimed at ensuring the safety of the Liberty Pipeline should be focussed on minimizing the risk posed by operational failures and third party activities. This suggests that efforts should be focused on such activities as operator training, surveillance, and monitoring.
- (c) the behaviour of a steel pipe-in-pipe that is exposed to operational failures should be investigated further. The work should be aimed at obtaining better definition of the scenarios that will occur, and the pipe response to these events.

**State Fire Marshal's Position on Double-Walled Piping for
Hazardous Liquid Pipeline Systems (California State Fire
Marshall, pipeline Safety Division, October 30, 1998)**

#0003
10-30-98

INFORMATION BULLETIN

Date Issued: October 30, 1998

**SUBJECT: STATE FIRE MARSHAL'S POSITION ON
DOUBLE-WALLED PIPING FOR HAZARDOUS
LIQUID PIPELINE SYSTEMS**

The California State Fire Marshal (CSFM) prohibits the installation of double-walled pipe for jurisdictional hazardous liquid pipeline systems. Our opposition is based on reasons of legal jurisdiction, design and construction difficulties, operation and maintenance problems, risk to the public and to the environment, and economic impact. Let us explain each of these in more detail.

Legal Jurisdiction: We believe that other state or local agencies are preempted by law from issuing requirements concerning the safety of any hazardous liquid pipeline.

The federal Hazardous Liquid Pipeline Safety Act of 1979 establishes the basic safety standards for the transportation of hazardous liquids and pipeline facilities. Authority for enforcement of this law rests with the US Department of Transportation's Office of Pipeline Safety (OPS). Specific federal regulations concerning the safety of hazardous liquid pipelines are found in parts 190, 195, 199 and 40 of the Code of Federal Regulations. CSFM's Pipeline Safety Program has been authorized by OPS to enforce these federal standards.

Hand-in-hand with the federal regulations, the Elder California Pipeline Safety Act (Chapter 5.5, California Government Code) directs that CSFM has "exclusive safety, regulatory and enforcement authority over intrastate hazardous liquid pipelines" within this State. This authority extends to the design, construction, operation and maintenance of these pipelines. As such, this code preempts other requirements which are inconsistent with standards enforced by CSFM.

Design and Construction: Difficulties in designing and constructing a double-walled system will be numerous and complicated. However, three of the more significant issues are:

- **Cathodic Protection:** If the outer pipe is to serve as secondary containment, both inner and outer pipes must be cathodically protected. In addition to the considerable engineering and installation difficulties involved (such as the installation of test leads on the inner pipe), this duplicate system may be a serious economic burden to the pipeline operator due to increased *installation and maintenance costs*.
- **Valves:** Installation of block valves or other appurtenances will be extremely difficult in a double-wall system.

- **Bends:** Installation of pipelines requires fabrication of directional bends and turns in the field. This task will be significantly complicated with the introduction of two concentric pipes of different diameters.

Operation and Maintenance: Double-wall pipe used in hazardous liquid pipeline service will make it extremely difficult if not impossible for the pipeline operator to comply with normal operation and maintenance requirements and may profoundly affect the operator's ability to respond quickly during an emergency. For example:

- **Corrosion:** The operator will have difficulty identifying general corrosion that has reduced wall thickness of the inner pipe to less than that required for maximum operating pressure. It will also be difficult to identify areas of localized corrosion pitting to the degree where leakage might result.
- **Unintended Movement/Abnormal Loading:** The operator will have difficulty assessing the effects on the serviceability of the inner pipe from unintended movement or abnormal loading of the pipeline caused by events such as earthquake, landslide or flood.
- **Leak Detection and Hazard Mitigation:** The operator will have more difficulty detecting and locating the site of a leak or rupture. Should a release occur, hydrocarbons will tend to fill the voids of the annular spaces between the inner and outer pipes. Presence of these flammable or combustible vapors make repair operation more dangerous, more arduous, more time-consuming and more costly for the emergency responders (fire, health, police agencies, etc.) and the operator.
- **Thermal Stress:** Double-walled pipe introduces serious stress on the pipeline system due to thermal expansion and contraction. While significant, the impact of this effect varies with the differing diameter and thermal environment of each pipe.
- **Electrical Short Circuiting:** Electrical isolation of the inner and outer pipe is necessary to avoid electrical shorts. Any metal-to-metal contact of inner and outer pipes caused by the previously identified thermal expansion-contraction may result in an electrical short form currents generated by the cathodic protection of the pipeline. In addition, the complications arising from field fabrication of pipe bends will most probably allow areas where the distances between the inner and outer pipes may be compromised. This underscores two serious problems:
 - (a) There is an added risk of pipeline failure caused by corrosion pitting due to electrical shorts rendering the cathodic protection system useless; and
 - (b) The short may act as a source of ignition if flammable or combustible vapors have been released through pinhole leaks. This situation could result in a catastrophic incident.

Risk to the Public and to the Environment: Regulations have been established at the federal and state level to assure minimal risk to the public and the environment. The design, construction, operation and maintenance difficulties listed above serve as some examples of how the proposed installation of double-wall pipeline is contrary to established law, regulation and established engineering principles and could compromise public and environmental safety.

Each case where the design and installation of the system is made more difficult results in increasing the chance that a mistake will be made. Each instance where there is more difficulty

in identifying corrosion, pipe stress, or cathodic protection failures increases the risk that the operator will not be able to successfully identify a problem before it becomes a crisis. All of these result in increasing the risk to the safety of the public and the environment.

Economic Impact: As is done across this country, compliance with established federal and state standards assures that crude oil and petroleum products may be transported with minimal risk to the public and the environment. The economic impact of operating and maintaining a pipeline meeting the requirements of federal and State standards is not a consideration. However, in this case, the proposal for double-wall construction adds significant operator costs for design, construction, operation and maintenance while increasing the risk to the public and the environment.

Questions regarding this Bulletin or any issue concerning pipeline safety may be directed to:

Nancy Wolfe, Chief
Hazardous Materials Safety Division
CDF/Office of the State Fire Marshal
P.O. Box 944246
Sacramento, CA 94244-2460
916/445-8477 (phone) 916/445-8526 (fax)

**Survey of Proposed Liberty Project Gravel Source Areas for
Evidence of Bird and Mammal Use (MMS, 2001)**

Survey Of Proposed Liberty Project Gravel Source Areas For Evidence Of Bird And Mammal Use

by Joel D. Hubbard and Richard T. Prentki

Abstract

A bird and mammal survey of a small gravel island in the Kadleroshilik River 1.4 miles upstream (south) from the Beaufort Sea, proposed as a source of gravel for the Liberty Project by BPXA in addition to surrounding mainland areas, was carried out in late June 2001. This was followed by a brief survey of the Duck Island gravel mine near Deadhorse. Thirty bird species were identified in the Kadleroshilik area, dominated by shorebirds, waterfowl, and loons. Most noteworthy was the presence on the island of a probable buff-breasted sandpiper mating lek with four males still present. This species is an uncommon breeder on the Arctic Coastal Plain. Its world population probably numbers fewer than 20,000 individuals. Nesting by five bird species on the island was confirmed or considered highly probable as a result of the behavior of individuals observed. Individuals or evidence of occurrence of six mammal species was observed on the island. The arctic ground squirrel was the only common species. The island was characterized by dry-barren or sparsely vegetated gravel habitats rather than diverse riparian habitats.

A. Introduction

BPXA has proposed an island in the lower Kadleroshilik River as a source of gravel for constructing the Liberty island and pads for the pipeline landfall and Badami pipeline junction (BPXA, 2000). In comments discussed at a November 27, 2000, meeting with Minerals Management Service (MMS), the Fish and Wildlife Service (FWS) implied that this island, because of its probable riparian habitat affinities as a result of being located in a river corridor, was likely to have a species diversity comparable to the relatively high diversity found in riparian habitats in the Arctic National Wildlife Refuge (ANWR) (Garner and Reynolds, 1986). Although strictly speaking, some habitats

occurring on a gravel island in the Kadleroshilik River might be expected to be characterized as “riparian,” they definitely are not comparable in variety or quality to riparian habitats that occur in ANWR. In that area, riparian habitats (including those adjacent to streams, sloughs, and ponds in tundra areas as well as rivers) support the highest mean densities of all birds, and among the highest diversity of nesting species of any habitat type. However, a gradient of varying willow height produces a variety of passerine habitats in ANWR not available on this gravel island, where willows are dwarf prostrate, and a substantial portion of the island is sparsely vegetated or unvegetated gravel. Also, various tundra communities, with a much greater diversity of grasses, sedges, forbs, and several types of waterbodies included in the riparian habitat type in ANWR, would provide a greater variety of shorebird and waterfowl habitats than this gravel island where the landscape is dominated by dry barren vegetation complexes. Given the almost certainly greater diversity of habitats associated with the diverse aquatic and tundra habitat types in ANWR than on this gravel island, a less diverse avian community would be expected to be present.

A BPXA contractor team visited the site on August 7, 1998, to describe vegetation and habitats on the island and vicinity (Noel and McKendrick, 2000), but they reported no systematic observations of wildlife. In recent comments on the Liberty draft EIS, the FWS suggested that MMS should identify avian species that occur on the island or, if avian survey data are not available, should address “expected” avian diversity and densities by habitat class. This report presents results of an MMS survey to characterize use of the island by birds and mammals and provides information necessary to estimate potentially adverse impacts of obtaining gravel there rather than from the established Duck Island gravel mine, proposed as an alternative source of gravel for this project.

B. Objectives

The primary goal of this survey was to document evidence of bird and mammal presence on a gravel island in the Kadleroshilik River that is proposed as a source of gravel for the BPXA Liberty Project. Secondary goals included surveying mainland areas adjacent to the island and the Duck Island gravel-mine site on the Sagavanirktok River Delta to document bird and mammal presence. In addition, the survey was undertaken to document habitat use and evidence of breeding activity in these areas.

C. Methods

To minimize disturbance to any birds or mammals present on the Kadleroshilik River island, the initial approach via helicopter was from the Beaufort Sea (north) to the northern end of the island, approximately 1.4 miles south of the coast. This end had a more barren appearance than most of the remainder of the island and, it was assumed, would receive less use by birds and mammals. Prior to turning inland from the Beaufort coastline, the approximate location of the proposed pipeline landfall site (known coordinates located by aircraft GPS) and alternate pipeline landfall site (east of the proposed landfall) along the Beaufort shoreline were observed and photographed from the air.

The island was stratified into four sections with marked lines of separation to facilitate the location of individual birds observed during a systematic survey of the island. Each section was walked by a pair of observers maintaining an approximate 100-foot separation while following adjoining pairs of parallel north-south routes. Sufficient numbers of parallel routes were traversed in each section such that no point was more than 50 feet from an observer. Coordinates (latitude, longitude) were obtained for the termini of separation lines defining the sections using a handheld GPS unit (north end of the northernmost section defined by a single point). Using ArcView GIS, the island area systematically surveyed was calculated as the sum of polygons representing land cover classes described by Noel and McKendrick (2000; Noel, pers. commun., 2001). Numbers of individuals of each species were tallied for each section and totaled for the island, and species densities were determined as numbers per square kilometer.

The island and adjoining mainland areas also were surveyed opportunistically for the presence of bird species. An area species list was compiled from lists maintained for each local subarea. Coordinates for each nest located on the island were determined using a handheld GPS unit as was the general location of other sites of activity.

The presence of mammal species was tallied opportunistically in the course of daily activities. Observations included individuals present on the island, tracks, burrows, scats, and other indications of activity. A

complete survey of the island was made for active arctic ground squirrel burrows, as evidenced by signs of recent excavation. Coordinates of single burrows or aggregations were determined using a handheld GPS unit.

The Duck Island gravel mine, located east of Deadhorse at the base of the Sagavanirktok River Delta along the road to the Endicott development, also was surveyed for the presence of bird species. The entire perimeter (approximately 2 miles) of the flat-topped berm enclosing the mine was surveyed. The berm, presumably comprised of the original mine overburden, varies from approximately 50-200 feet in width and rises from about 5-30 feet above the surrounding tundra. Parallel routes along the top of the berm were walked by a pair of observers such that all portions were observed from a distance of 50 feet or less.

D. Results

1. Bird Species Diversity

Thirteen species were observed on the island, and individuals of many of these plus 10 additional species were observed flying over the island or swimming in adjacent river channels (Table 1). Species observed during surveys of adjacent mainland areas, or observed on or over them from the island, totaled 23 species in the area to the west and south, 10 species in a smaller area to the east, and 4 species in the Kadleroshilik River mouth area. These totals may not include all species present in these areas due to the brief duration of these surveys. Overall, 30 bird species were identified in the Kadleroshilik area (Table 2). The lower bird diversity observed on the island is reflected in a Shannon-Wiener diversity index (Zar, 1999) of 1.031, compared to 1.395 for the surrounding mainland areas. Observed bird diversity at the Duck Island gravel mine was lower than on the Kadleroshilik island, with just six species noted during a relatively short visit (Table 4).

2. Bird Species Abundance and Habitat Use

Species with four or more individuals observed on the island at least once were lesser golden-plover, buff-breasted sandpiper, long-tailed jaeger, rock ptarmigan, and Lapland longspur (Table 2). Numbers of Canada goose, white-fronted goose, and northern pintail also exceeded this value but they were observed more frequently flying over the island or on adjacent mainland areas than actually landing on the island, which occurred only a few times. Most individuals of most species were observed on the southern two-thirds of the island. This part of the island appeared to contain more areas of moist or taller forb/grass vegetation,

which may provide more preferred foraging and nesting habitat for most species than the more sparsely vegetated northern third. Noel and McKendrick (2000) described moist habitats only on the southern portion of the island. It was apparent that the island does not contain moist or wet habitats favored by many species in nearly the same proportion as surrounding mainland areas that were visited.

Bird species that were nesting on the island, or appeared to be so as a result of consistent presence in specific areas or their behavior, included black-bellied plover, lesser golden-plover, ruddy turnstone, rock ptarmigan, and Lapland longspur. Nests (one each) were found for the two plover species and one pair of longspurs. Consistent presence in separated areas, simultaneous observations of individuals in separated areas, behavior, and/or presence of both sexes suggested that the following numbers of breeding pairs were present: black-bellied plover, 1; lesser golden plover, 1; ruddy turnstone, 2; rock ptarmigan, 2; and Lapland longspur, 3 (Table 3). The nests discovered and most activity suggesting a nearby nest were located on the southern two-thirds of the island. Both plover nests were located on sparsely vegetated gravel areas within Noel and McKendrick's class IXb dry barren/dwarf shrub, forb, grass complex on which the cryptically colored eggs were well concealed. The longspur nest, and most activity by longspurs, were located in taller forb/grass vegetation. Likewise, occurrence of rock ptarmigan was confined primarily to areas of forb/grass vegetation. Both plover species and the turnstone were observed frequently in gravel or sparsely vegetated habitats.

Four buff-breasted sandpipers, an uncommon migrant and breeder in the Beaufort Sea area (Johnson and Herter, 1989), were observed in a limited area on the southern portion of the island. At least two and probably all four of the individuals were observed at various times giving the "wing-flash" display (suddenly raising one wing to a vertical position, lowering it, and repeating) characteristically given by males when advertising territories on this apparent lek area. It was not clear whether these displays were being given in the usual context of territorial advertisement shortly after the typical peak mating period, or as a stress response to human presence. They also were observed giving the raised double-wing display usually given earlier in the breeding period when one or more females are present on a territory. Two individuals approached to within about 6 feet of one observer, an example of the well-known tameness of this species. No individuals confirmed as females were observed, and no nests were located on the island. However, this species has a promiscuous mating system, so males and females do not form pairs, and females have been found nesting up to 6.2 kilometers from a lek (Lanctot and Laredo, 1994). Most females probably were on nests located elsewhere when this survey took place in late June. Vegetation where a buff-breasted sandpiper nest was found at the Duck Island gravel mine (see below) was more lush,

as on mainland areas surrounding the Kadleroshilik island, than that generally occurring on the island; this suggests that little or no nesting should be expected to occur on the island.

At the Duck Island gravel mine, the Lapland longspur was the only species with more than three individuals observed. Three species—semi-palmated plover, semi-palmated sandpiper, and Lapland longspur—could find appropriate nest habitat on the berm; and from the numbers present and behavior observed, probably a few were nesting there. Much of the berm surface was lightly vegetated, but on the south side of the mine excavation cover was typical well-vegetated dry forb/grass tundra. A buff-breasted sandpiper nest was located in this area. Although a few longspurs may have been nesting on the berm, some observed during the survey had flown up from the surrounding tundra to forage or possibly to gain a more prominent observation post.

3. Bird Species Density

The area surveyed for bird density on the island was approximately 0.19 square kilometer. As a result of such a small sample size (small total area with one replicate), most species occurring on the island would be expected to appear to be present at much greater density (on a per-square-kilometer basis) than if found on a few of a large sample of random sample plots. Thus for most species found on the island, equivalent densities of individuals and nests (those found plus those assumed from behavior of individuals or pairs) exceeded by substantial amounts those recorded by TERA (1995) on 30 mainland plots located east of the Kadleroshilik River. However, densities of semi-palmated and pectoral sandpipers, species that are abundant on mainland areas, were one-half and one-sixth those found in the mainland study area. No evidence of nesting by either was observed. Also, nesting habitat on the island for the abundant Lapland longspur is marginal, as reflected by a density about one-half that of the mainland area. Occurrence of a buff-breasted sandpiper lek on the island resulted in high density of this species, but there was no evidence of nesting.

4. Mammals

Individuals or evidence of occurrence of six mammal species was observed. Arctic ground squirrel was the most common mammal species on the island. A census of burrow entrances presumed to be active due to the presence of freshly excavated soil resulted in a count of 60 sites with numbers of entrances per site ranging from one to greater than six. Density of burrow sites and burrow entrances on the island was equivalent to 280.4 per square kilometer and 752.3 per square kilometer, respectively. Because burrows may have multiple entrances, the true density of squirrels on

the island probably lies in between these two figures. These figures are considerably above densities of 5 per square kilometer found by Batzli, et al. (1980) in two areas near Barrow.

Three groups of caribou (5, 5, and 15 individuals) were observed on the island over the course of 3 days. Groups frequently were observed on the mainland areas. Large, trench-like excavations in several ground squirrel burrow areas suggested the occasional occurrence of brown bears. Scats and tracks of arctic fox, and scats of a size to suggest arctic wolf, almost completely comprised of lemming bones, were observed on the island. Small burrows and runs assumed to be those of lemmings were observed at 15 sites on the island. One recently deceased collared lemming was observed, appearing in good condition and only slightly consumed. The carcass disappeared later in the day.

E. Discussion

Most noteworthy on the Kadleroshilik island was the presence of four buff-breasted sandpiper males occupying an apparent lek. Such areas are used during the breeding period for courtship display by males and mating. Establishment of leks is extremely rare among shorebirds (3 species of about 200 worldwide). While the exact location of a lek may vary somewhat from year to year, they often occur at traditional areas along rivers. It is not known if this island is a traditional lek site, but it appears to satisfy the requirements of location and habitat. If this is a routinely used area, it would represent a valuable resource for this species in the area. During the peak of courtship the number of males at a lek and the specific individuals present changes daily. Males may display on leks that are separated by several kilometers on successive days (Lanctot and Laredo, 1994). Leks may function to make it easier for females to find males, to allow females to compare males, and to minimize disturbance at nest sites located away from the lek area (Bradbury, 1981; Phillips, 1990). This species was reduced from an estimated hundreds of thousands or millions to near extinction in the 1920's by human activities (Lanctot and Laredo, 1994). Current estimates of the population size are very approximate, suggesting it probably numbers 10,000-20,000 individuals. The species' summer range includes Canadian high arctic islands and northern Alaska, with low numbers in far eastern Russia. They winter in southeastern South America. Thus, any action that could have a negative impact on this species' reproductive success may represent more than a minor threat to its small population.

Although a buff-breasted sandpiper nest was found at the Duck Island gravel mine, this occurrence is not considered an argument against obtaining Liberty gravel from this site. Nest sites probably are scattered widely and certainly would be expected to occur with greater frequency in this area closer to Prudhoe Bay, where nest densities of 1.0 per

square kilometer have been observed, while in the same study no nests were located within the Kadleroshilik area study plots (TERA, 1995).

As noted above, densities of most species expanded to a per-square-kilometer basis probably represent an inflated estimate of abundance on the island. Any species occurring or nesting on the island even in rather small numbers would appear to be present at much greater density than if tallied, for example, on just a few plots of a large sample of plots randomly scattered through a much larger area containing a greater proportion of more typical tundra habitats. Likewise, because of low habitat diversity and/or availability on the island compared to mainland areas, those species that are abundant on the mainland but for which little typical breeding habitat is available on the island, such as semi-palmated and pectoral sandpipers and Lapland longspur, will appear to be present at very low densities.

Regarding speculation concerning the riparian affinities of habitats on this island, we did not find the variety or quality of habitats that occur in mainland areas, and certainly not as might be found in definitive riparian areas with willow gradients representing additional bird habitats that, as suggested by the FWS, exist in ANWR. Such habitats support the highest mean densities of all birds, and among the highest diversity of nesting species of any habitat type. However, a gradient of varying willow height is not available on this gravel island where willows are dwarf prostrate, and a substantial proportion of the island is sparsely vegetated. Also, various tundra communities, with a much greater diversity of grasses, sedges, forbs, and several types of waterbodies included in the riparian habitat type in ANWR, provide a greater variety of shorebird and waterfowl habitats than on this gravel island where the landscape is dominated by dry, dry-barren, and sparsely vegetated river gravel habitats. Given the almost certainly greater diversity of habitats associated with the diverse aquatic and tundra habitat types in ANWR than on this gravel island, a less diverse avian community would be expected.

F. Conclusions

Although data are lacking to confirm the Kadleroshilik River island as a traditional buff-breasted sandpiper lek site, the presence of four males well after the presumed peak of mating in mid-June suggests this as a possibility. If so, it could represent an important resource for this uncommon arctic coastal plain species. Destruction of the site could represent more than a minor threat to reproductive success of the local population. In this case, the site should receive consideration for preservation because a large proportion of the population apparently breeds more successfully when such lek areas are used.

Given the relatively low habitat diversity and availability on the island avifaunal presence, particularly of shorebirds, was greater than expected. However, speculation by the FWS regarding the potential for presence of a diverse suite of riparian habitats on the island, and associated high bird species diversity, was not confirmed.

Although a buff-breasted sandpiper nest was found at the Duck Island gravel mine, this occurrence is not considered an argument against obtaining Liberty gravel from this site because nests are widely dispersed in this area. Because of this species' unusual breeding system, numbers of lek areas occupied by multiple males are likely to be much rarer than nest sites maintained by female buff-breasted sandpipers. In terms of other bird species present, limited habitat availability at the Duck Island site resulted in lower species diversity than was observed on the Kadleroshilik island.

Mammal diversity on the island during this survey was relatively low. However, evidence of occasional use by several species not present or observed during this interval suggests the fauna is representative of diversity in mainland areas. Except for arctic ground squirrel, mammal abundance probably is lower than in mainland areas.

Phillips, J.B. 1990. Lek behavior in birds: do displaying males reduce nest predation? *Animal Behavior* 39:555-565.

Troy Ecological Research Associates (TERA). 1995. Preliminary characterization of summer bird use of the proposed Badami Development Area. Report submitted to BP Exploration (Alaska) Inc. 29pp.

Zar, J.H. 1999. *Biostatistical Analysis*. Prentice-Hall, Upper Saddle River, N.J.

LITERATURE CITED

- Batzli, G.O., R.G. White, S.F. MacLean, Jr., F.A. Pitelka, and B.D. Collier. 1980. The Herbivore-Based Trophic system. In J. Brown, P.C. Miller, L.L. Tieszen, and F.L. Bunnell (eds.). *An Arctic Ecosystem, The Coastal Tundra at Barrow, Alaska*. US/IBP Synthesis Series, Vol. 12, pp. 335-410.
- BP Exploration (Alaska) Inc. (BPXA). 2000. Liberty Development Project, Development and Production Plan, Revision 2, 119pp + appendices.
- Bradbury, J.W., R.M. Gibson, and I.M. Tsai. 1986. Hotspots and the dispersion of leks. *Animal Behavior* 34:1694-1709.
- Garner, G.W. and P.E. Reynolds. 1986. Arctic National Wildlife Refuge coastal plain resource assessment. Final Report--1985 Update report of baseline study of the fish, wildlife, and their habitats. Vol. 1. U.S. Fish and Wildlife Service.
- Johnson, S.R. and D.R. Herter. 1989. The Birds of the Beaufort Sea. BP Exploration (Alaska) Inc. 372 pp.
- Lancot, R.B. and C.D. Laredo. 1994. Buff breasted Sandpiper (*Tryngites subruficollis*). In *The Birds of North America*, No. 91 (A. Poole and F. Gill, Eds.). Philadelphia: The Academy of Natural Sciences; Washington D.C.: The American Ornithologists' Union.
- Noel, L.E. and J.D. McKendrick. 2000. Land cover map for the Liberty mine site. Report prepared for BPXA by LGL Alaska Research Associates, Inc. 17 pp + appendices.

Table 1. Bird Species Observed on and near Kadleroshilik River Island Proposed as Gravel Source for the Liberty Project

On Kadleroshilik River Island	Overflying Island or Swimming in River
Greater White-fronted Goose	Pacific Loon
Canada Goose	Red-throated Loon
Northern Pintail	Greater White-fronted Goose
Black-bellied Plover	Canada Goose
Lesser Golden Plover	Brant
Ruddy Turnstone	Long-tailed Duck
Semi-palmated Sandpiper	Whimbrel
Pectoral Sandpiper	Semi-palmated Sandpiper
Buff-breasted Sandpiper	Parasitic Jaeger
Long-tailed Jaeger	Long-tailed Jaeger
Glaucous Gull	Glaucous Gull
Rock Ptarmigan	Arctic Tern
Lapland Longspur	Golden Eagle
	Northern Harrier
	Common Raven

Table 2. Bird Species Observed in the Lower Kadleroshilik River Area

Pacific Loon	Dunlin+
Red-throated Loon	Ruddy Turnstone*
Tundra Swan+	Semi-palmated Sandpiper
Greater White-fronted Goose	Pectoral Sandpiper
Snow Goose+	Buff-breasted Sandpiper*
Canada Goose	Parasitic Jaeger
Brant	Long-tailed Jaeger
Northern Pintail	Glaucous Gull
Long-tailed Duck	Arctic Tern
Red-breasted Merganser+	Golden Eagle
Black-bellied Plover	Northern Harrier
Lesser Golden Plover	Rock Ptarmigan*
Whimbrel	Willow Ptarmigan+
Red-necked Phalarope+	Common Raven
Long-billed Dowitcher+	Lapland Longspur

*Observed only on or over island.

+Observed only on or over mainland or rivermouth areas.

Table 3. Bird Species Confirmed as Nesting on the Kadleroshilik Island, or Probable Nesters, and Probable Numbers of Nests

Black-bellied Plover-1
Lesser Golden-Plover-1
Ruddy Turnstone (probable)-2
Rock Ptarmigan (probable)-2
Lapland Longspur-3

Table 4. Bird Species Observed at the Duck Island Gravel Mine Area

Canada Goose (flyover)
Semi-palmated plover
Semi-palmated Sandpiper
Buff-breasted Sandpiper (nest)
Glaucous Gull
Sabine's Gull (flyover)
Lapland Longspur
Snow Bunting

Numerical Modeling of the Fate of Suspended Sediments Resulting from the Liberty Project

This appendix is available on the CD-ROM (MMS 2002-019 CD) and on the Internet (<http://www.mms.gov/alaska/cproject/liberty>).

**NUMERICAL MODELING OF THE FATE OF SUSPENDED SEDIMENTS
RESULTING FROM THE LIBERTY PROJECT**

Billy H. Johnson
Computational Hydraulics and Transport
300 Front Street
Edwards, MS 39066

Charles Dickerson
DynCorp
3530 Manor Drive
Vicksburg, MS 39180

and

Douglas G. Clarke
US Army Engineer Research and Development Center
Wetlands and Coastal Ecology Branch (EE-W)
3909 Halls Ferry Road
Vicksburg, MS 39180

March 2002

Prepared for: BP Exploration (Alaska) Inc. (BPXA)
900 East Benson Boulevard
P.O. Box 196612
Anchorage, Alaska 99519-6612

TABLE OF CONTENTS

	<u>Page</u>
INTRODUCTION	3
Background	3
Purpose	3
THEORETICAL ASPECTS OF SSFATE	3
MODELING APPROACH	4
Model Grid	4
Geographical Information Data	5
Hydrodynamics	5
Sediment Sources	5
Model Coefficients	7
RESULTS FROM TRENCHING SIMULATIONS	7
Simulation 1 – 1 m Water Depth	9
Simulation 2 – 2 m Water Depth	10
Simulation 3 – 3 m Water Depth	10
Simulation 4 – 4 m Water Depth	11
Simulation 5 – 3 m Water Depth and 0.5*Flow Field	11
RESULTS FROM DISPOSAL OF STOCKPILED MATERIAL	12
Zone 1 Disposal	12
Effect of Flow Velocity	12
Effect of Vertical Diffusion Coefficient	13
Effect of Critical Shear Stresses	14
Zone 2 Disposal	14
Effect of Flow Velocity	14
Effect of Vertical Diffusion Coefficient	15
Effect of Critical Shear Stresses	15
SUMMARY AND CONCLUSIONS	16
Summary	16
Conclusions	17
REFERENCES	17
FIGURES 1-144	
APPENDIX A: Description of the SSFATE Numerical Modeling System	

INTRODUCTION

Background

BP Exploration (Alaska) Inc. (BPXA) plans to develop the Liberty oil field in the Beaufort Sea. For this development, BPXA has proposed building an island (Liberty Island) that would be connected to the land-based Badami Pipeline System by installing a pipeline beneath the sea floor. The path of the pipeline is shown in Figure 1. Kelp beds resident in boulder patch areas located to the northwest of the path of the proposed pipeline could be adversely affected by a reduction in available light caused by increased suspended sediment concentrations resulting from construction activities. In addition, there is some concern about the quantity of sediment that may be deposited over the boulder patch areas.

To aid in the permitting process, the U.S. Army Corps of Engineers, Alaska District requested that BPXA have the U.S. Army Engineer Research and Development Center (ERDC) apply the recently developed numerical model called SSFATE (Suspended Sediment **FATE**) to provide insight on the spatial scales and magnitude of suspended sediment plumes associated with the construction of the under-water pipeline from the land out to Liberty Island, as well as the fate of sediments stockpiled on the surface ice that will be released into the water during the ice breakup period in early spring.

Purpose

Since no data are available for validation of the SSFATE computations, the purpose of the modeling presented herein is to demonstrate capabilities of SSFATE in this application. The model's output can serve as a preliminary screening tool to examine probable dispersion and deposition patterns of sediments associated with the construction and ice break-up phases of the project. During construction of the pipeline, plans call for field data to be collected that would provide a basis for validation of SSFATE simulations.

THEORETICAL ASPECTS OF THE SSFATE MODEL

SSFATE was developed under the Dredging Operations and Environmental Research Program (DOER) of the US Army Corps of Engineers to address questions related to environmental windows, such as "What is a safe period for dredging operations at a particular site?" SSFATE is a versatile computer modeling system containing many features suitable for the Liberty Island application. For example, ambient currents, which are required for operation of the basic computational model, can either be imported from a numerical hydrodynamic model or drawn graphically using interpolation of limited field data. Model output consists of concentration contours in both horizontal and vertical planes, time series plots of suspended sediment concentrations, and the spatial distribution of sediment deposited on the sea floor. In addition, particle movement can be

animated over Geographical Information System (GIS) layers depicting sensitive environmental areas such as the boulder patch areas (see Figure 1).

At the heart of the modeling system is a computational particle-based model using a random walk procedure that predicts the transport, dispersion, and settling of suspended dredged material released to the water column. An integral component of the modeling system is the specification of the sediment source strength and its vertical distribution. An algorithm based on the Turbidity Generation Unit concept proposed by Nakai (1978) is contained in the model to compute sediment sources for particular types of dredges. However, for the Liberty Island application, a generic source algorithm was employed in which the source strength and its vertical distribution are specified by the user. Multiple point sources at different locations in the modeled area, as well as, multiple line sources with varying times of occurrences during the simulation can be specified in SSFATE. This feature was important for the Liberty application.

The settling algorithm in SSFATE, which is based on suspended sediment concentrations and shear stresses, is an integral part of the computations. Settling of mixtures of particles, some of which may be cohesive in nature, is a complicated process with the different size classes interacting, i.e., the settling of one particle type is not independent of the other types. An account of this aspect of the model, as well as other theoretical details of SSFATE, is presented in the Dredging Operations and Environmental Research Program Technical Note attached as Appendix A of this report. Additional discussion of various theoretical aspects of SSFATE will be offered during the presentation of model results to explain the computations from this phase of the Liberty Island application of SSFATE.

MODELING APPROACH

Model Grid

The first task in applying SSFATE is to select the geographical area over which a numerical grid will be constructed. An area containing the proposed pipeline, the boulder patch areas, and enough of the surrounding area to contain the suspended sediment plumes likely to be generated as a result of the construction activities was selected. The numerical grid specified for the Liberty application (see Figure 2) was automatically generated by SSFATE as a 250 x 250 rectangular land-water grid extending over a distance of about 32 km in the N/S direction and about 37 km in the E/W direction.

A NOAA bathymetric database was initially used to set water depths on the numerical grid shown in Figure 2. With the pipeline construction assumed to occur during the winter when surface ice is about 2 m (approximately 6 ft) thick, effective water depths in the area to be modeled range from close to zero near the shoreline to 4- 5 m near the Liberty Island. During initial simulations, it was noted that problems developed when computing the concentration of suspended sediment plumes over variable bathymetry. The timeline on conducting the Liberty Study did not allow for SSFATE modifications to

correct the problem. Therefore, in the results to be presented, each simulation assumed a constant water depth. However, that depth varied depending on the location of the sediment source. For example, in the trenching simulation where the source was close to the shoreline the water depth was assumed to be 1 m, whereas, in the simulation where the source was near the island the water depth was specified to be 4 m.

Geographical Information Data

Various layers of geographical based data can be imported into SSFATE and displayed during animation of the movement of the sediment particles. Maps of the boulder patch areas and proposed pipeline and island locations were provided by BPXA and imported into SSFATE. This layer of geographical information can be seen in Figure 1.

Hydrodynamics

A crucial component of the data required for operation of SSFATE is the specification of hydrodynamic data, i.e. water velocities. Few quantitative data on water velocity and general circulation patterns under the ice cover exist. Information provided by the Alaska District of the U.S. Army Corps of Engineers (see Reference 3) indicates that the net drift of the water mass under the ice is to the northwest at about 3-4 cm/sec. ADCP data were provided by Dr. Thomas Weingartner of the University of Alaska, which includes a year-long record of current magnitude and direction at a station offshore from the Liberty Island location. These data were analyzed for additional insight into the dominant circulation patterns in the projected model domain. Based on these data, during the period when ice covers the water surface the magnitude of the current is generally 3-4 cm/sec, but at times can be as high as 10 cm/sec. The direction is highly variable, with movement toward the northwest occurring about 60% of the time. Because the random component could not be accommodated in the hydrodynamic input, it was decided to model the worst-case condition, i.e. assume the net flow is uniformly toward the northwest with a magnitude of 3-4 cm/sec. The flow field that was “sketched” and applied for most of the simulations during the digging of the trench is shown in Figure 3. Some simulations, e.g., the release of the stockpiled material during breakup of the surface ice, were made with the flow field shown in Figure 3 multiplied by factors of 1.5, 2.0, and 3.0.

Sediment Sources

Suspended sediment plumes were computed as a result of activities associated with both digging of the trench in which the pipeline will be placed, as well as, the release during breakup of the surface ice of dredged material stockpiled on the ice surface. The information required to specify a sediment source is the grain size distribution of the dredged material, the total percent of the sediment suspended in the water column, the rate of dredging or disposal of material, the vertical distribution of the suspended material in the water column, and the temporal and spatial representation of the source.

The grain size distribution employed was determined from data collected by BPXA in May 2001. These data showed that the percent fines for material dredged near the

shoreline was about 45%, whereas the percent fines near the offshore end of the trench at Liberty Island was about 70%. Based on data collected at the Northstar Project (see Reference 3) the percent of sediment suspended was varied based on the water depth modeled. For example, in a water depth of 1 m, the percent of sediment suspended as a result of digging the trench was assumed to be 2%, whereas in a water depth of 4 m, the percent was assumed to be 10%. Linear interpolation was used to set the suspension percentages for other depths. In all simulations, the suspended material released was assumed to be uniform throughout the water column.

The trench in which the pipeline will be laid will be dug using a backhoe operating from the ice surface. As the material is raised to the ice surface some material will be released in the water column. The sediment dredged will be placed on the ice surface and later used for backfill material. The assumption made is that the backfilled material will be lowered into the trench with the backhoe. During this activity, the amount of material lost to the water column should be less than when raising the material to the surface. Since no information was available to quantify this loss, it was assumed to be 25% of that lost while raising the material through the water column. Thus, assuming both digging and backfilling take place simultaneously, the percent of material suspended in the water column was assumed to be that due to digging plus 25% of that amount.

The total length of the trench to be dug under ice is about 5 km. Based on information provided in Reference 3, the size of the backhoe bucket will be 3 cu yd, with a cycle being completed each minute. The first approach tried to simulate the trenching activity was to specify a line source 5 km long in SSFATE, with particles being released along the line over several months. However, computational limitations in SSFATE did not allow for this simulation. The number of particles released in such a simulation would be in the millions. Therefore, the approach taken was to represent the trenching activity through four separate simulations. Each simulation assumed that sediment was released for 5 days, with the total time simulated being 10 days. With an estimated rate of 300 ft/day of trench being dug, the line source for each simulation was 1500 ft long. The four simulations were spaced along the length of the pipeline trench, with the water depth being 1 m, 2 m, 3 m, and 4 m, respectively.

From Reference 1, it is estimated that about 110,000 cu yd of the material placed on the ice will not be needed for backfilling of the pipeline. About 100,000 cu yd of the material will be placed in the location labeled Zone 1 in Figure 4 (from Reference 1), with the remaining 10,000 cu yd being placed in Zone 2. It is assumed that the material stockpiled on the ice surface will drop into the water during ice breakup over a period of 24 hours. Thus the rate of release of material from Zone 1 was assumed to be 4166 cu yd/hour and 417 cu yd/hour in Zone 2. With material in Zone 2 placed along the path of the trench, representing the disposal from Zone 2 as a line source appears reasonable. However, the disposal of material from Zone 1 occurs over an area of about 230 acres. This type of disposal isn't allowed in SSFATE. Thus, disposal from Zone 1 was approximated by specifying 12 different line sources covering the area of Zone 1, with material being released along each line over a 2 hour period. The water depth for simulation of the disposal of the stockpiled material was taken to be 3 m, with the percent of material

suspended in the water column and the grain size distribution taken to be the same as those for the 3 m case in the trenching simulations.

Model Coefficients

Coefficients in SSFATE that can be varied include the vertical and horizontal diffusion coefficients. These can be input by the user or the user can allow the model to compute the horizontal diffusion coefficient. As can be seen in Appendix A, these coefficients are employed in the random walk computations to provide a random transport of the particles along with the deterministic transport by the flow field shown in Figure 3. In all simulations, the horizontal coefficient was computed by SSFATE from the following expression:

$D_x = 6 H U$, where H is the water depth and U is the flow velocity.

The value selected for the vertical diffusion coefficient and its impact on model results are discussed later.

One model parameter that can influence the computed suspended sediment concentration is the particle multiplier. SSFATE automatically selects the number of particles to be created to represent the release of sediment based on the rate of release and the total time that material will be released. The suspended sediment concentration at a particular time is determined by how many particles (and thus how much material) are contained in a cell of the concentration grid. For all the Liberty simulations except one, the size of each concentration grid cell was set to be 50 m x 50 m x 0.5 m. Obviously, the more particles created to represent the total amount of released material the more accurate the computations will be. Experimentation revealed that a multiplier greater than 3 did not change the model results appreciably. Thus, all simulations used a multiplier of 3.

Other model parameters that have a significant influence on model results are those associated with the settling algorithm. These are discussed in Appendix A. The impact of changing the critical shear stresses for the sediment classes is discussed in the presentation of model results. It should be noted that many of these parameters / coefficients have a relatively wide range of values. Generally, when conducting a sediment transport study involving fine-grained material, site-specific material is collected and tested to establish these values. If Phase 2 of the Liberty Island Study is conducted, it is recommended that in situ sediments, site water, and total suspended solids (TSS) samples be collected for sediment testing.

RESULTS FROM TRENCHING SIMULATIONS

As noted above, modeling suspended sediment plumes generated by the trenching activity involved four separate runs. The water depths assumed for the runs were 1, 2, 3, and 4 m, with the shallower depth sites being closer to the shoreline. As discussed above,

each simulation assumed that digging took place for 5 days at a rate of 180 cu yd/hour and at a rate of 300 ft/day along the trench. Thus, each line source for the four runs was 1500 ft long. The simulation continued for an additional 5 days in each of the runs. Depending on the location of the site (and thus the water depth), the sediment characteristics and the percent of material released to the water column varied. This information is summarized in Tables 1 and 2 below.

Table 1. Percent of excavated sediment released to the water column in the trenching operation

<u>Water Depth</u>	<u>Percent Released</u>
1.0 m	2.50
2.0 m	5.50
3.0 m	9.50
4.0 m	12.50

Table 2. Grain size distribution of sediment

<u>Water Depth</u>	<u>% Clay</u>	<u>%F Silt</u>	<u>%MF Silt</u>	<u>%F Sand</u>	<u>%C Sand</u>
1.0 m	15.00	15.00	15.00	27.50	27.50
2.0 m	17.50	17.50	17.50	23.75	23.75
3.0 m	20.83	20.83	20.83	18.75	18.75
4.0 m	23.33	23.33	23.33	15.00	15.00

Except for one simulation (where the flow velocities were halved), all the trenching simulations used the flow field presented in Figure 3. A value of 0.000005 cm²/sec was specified for the vertical diffusion coefficient. Justification for selecting this value is discussed later. Values for the critical shear stresses presented in Appendix A were employed in all trenching simulations. Table 3 shows the values employed. As will be discussed later, some simulations of the stockpiled material that is released to the water column during the spring breakup of the surface ice used different values for these coefficients.

Table 3. Values of critical shear stresses (in Pascals) used in trenching simulations

<u>Sediment</u>	<u>τ_{ll}</u>	<u>τ_{ul}</u>
Clay	0.016	0.03
F Silt	0.03	0.06
MF Silt	0.06	0.20
F Sand	0.20	0.90

Values for the parameter “a” used to compute settling velocities (see Appendix A) were slightly changed from the values presented in Appendix A. These values, along with values for the upper and lower limits on concentration, are presented in Table 4. All other parameters in the settling algorithm were as given in Appendix A.

Table 4. Concentration limits and value of “a” used in trenching simulations

<u>Sediment</u>	<u>C_{ll} (mg/l)</u>	<u>C_{ul} (mg/l)</u>	<u>“a” (m/sec)</u>
Clay	50	1000	0.0005
F Silt	150	3000	0.0012
MF Silt	250	5000	0.0025
F Sand	400	8000	0.01
C Sand			0.10

Model results consisting of the thickness of deposited sediments and water column concentrations are presented at distances of 250, 500, 1000, 2500, 5000, 7500, and 10,000 m from the line sources along the centerline of the suspended sediment plume for each simulation.

Simulation 1 – 1 m Water Depth

Figure 5 shows the locations where time series plots of model results are presented for the first line source simulation using a water depth of 1.0 m. From Tables 1 and 2, it can be seen that 2.5% of the sediment is released in the water column, with 45% of the sediment consisting of clay and silts.

Figures 6-12 show the spatial distribution of deposited material along with time series plots at the various locations shown in Figure 5. It can be seen that deposition decreases with distance from the source, with the deposition thickness ranging from 0.125 mm at 250 m to 0.002 mm at 10,000 m along the centerline of the plume. Figure 13 shows a plot of deposition thickness with distance for all four runs. The 1 m water depth simulation is labeled FB1C, with FB4C, FB8C, and FB11C being the simulations with water depths of 2, 3, and 4 m, respectively.

Figures 14-20 show the concentration of suspended sediment in the vertical layer occupying the water depth from 0.5 m below the surface to the bottom, i.e., 1.0 m. Note that the labels on the plots show a depth of 1.0 m to 1.5 m. This is an error in SSFATE. One half of a meter should be subtracted from the depths shown on all concentration plots in the report. These plots show the spatial distribution of the MAXIMUM concentration that ever occurred during the simulation. The superimposed time series plots show the concentration in a particular computational cell. With the concentration cell being 50 m x 50 m x 0.5 m, coupled with the fact that there is significant randomness in the transport of particles, one should view the time series plots within the context of the maximum concentrations displayed near the cell that was “clicked” upon. The time series plots show maximum concentrations that range from about 700 mg/l at 250 m to about 110 mg/l at 10,000 m along the plume centerline.

It should be noted that the concentrations near the bottom in all the simulations discussed in this report are likely to be overestimated and the bottom deposition is likely to be underestimated by the model. The reason for this is due to the manner in which SSFATE settles material from the last layer in the water column. The amount of material settled is computed from the concentration in the bottom layer, the settling velocity of the particular particle size class, and the probability of deposition, which is related to shear stresses (see Appendix A). Once the amount of settled material is computed, the number of particles representing sediment mass in the bottom layer should be reduced by an amount equivalent to that lost to deposition. However, in the current version of SSFATE, only particles in the bottom layer that are “close” to the bottom have material subtracted away. This results in the possibility of less material being deposited.

Simulation 2 – 2 m Water Depth

The location of this line source and the stations for displaying time series results are shown on Figure 21. As noted, the water depth was taken to be 2 m. As indicated in Tables 1 and 2, the percent of material released in the water column was 5.5% and 52.5% of the excavated sediment is a combination of clay and silts.

Figures 22-28 show the spatial distribution of the deposited sediment along with the time series plots at the particular locations shown in Figure 21. It can be seen that the thickness of the deposited material ranges from 0.5 mm to about 0.0035 mm at distances 250 m to 10,000 m away from the source. Even though the water column is deeper than the previous simulation (water depth of 1 m), the deposition is greater. Recall, however, that the percent of sediment injected into the water column is 5.5% in 2 m of water and only 2.5% in 1 m of water.

Figures 29-35 show the maximum suspended sediment concentrations that occurred in the vertical layer from 0.5 m to 1.0 m (recall the statement above about subtracting 0.5 m from the displayed depths). These range from about 125 mg/l at 250 m to approximately 20 mg/l at 10,000 m from the source. Near-bottom (1.5 m – 2.0 m) concentrations are much higher. Figures 36-42 show maximum concentrations ranging from about 600 mg/l to 70 mg/l at the same locations. Again, it should be noted that these concentrations are likely to be overestimated and the bottom deposition is likely to be underestimated.

Simulation 3 – 3 m Water Depth

Figure 43 shows the location of the source and locations for plotting time series of bottom thickness and water column concentrations of suspended sediment. As can be seen from Tables 1 and 2, the percent of material suspended in the water column was 9.5%, with about 62.5 percent of the sediment being fined-grain.

Figures 44-50 show the computed bottom thickness of deposited material. The deposition ranges from about 1.0 mm to 0.0035 mm at distances 250 m to 10,000 m away from the source. Figures 51-57 show the maximum suspended sediment concentrations in the water column from 1.5 m to 2.0 m below the surface. The maximum values range from

about 400 mg/l to 25 mg/l at distances from 250 m to 10,000 m along the centerline of the plume. The near-bottom concentrations are presented in Figures 58-64. At the same locations as above, these values range from about 800 mg/l to 90 mg/l.

Simulation 4 – 4 m Water Depth

Figure 65 shows the location of the source and the locations for generating time series plots. The percent of sediment suspended in the water column for this simulation was 12.5%. From Table 2, it can be seen that about 70% of the dredged sediment consisted of clay and silts. One difference between this simulation and the others representing the construction of the pipeline is that the thickness of a concentration computational cell is 1.0 m, whereas, in the other simulations the thickness was 0.5 m. In this application, SSFATE would not run with a thickness of 0.5 m due to insufficient memory problems.

Figures 66-72 show the spatial distribution of the bottom deposition. From the time series plots at 250, 500, 1000, 2500, 5000, 7500, and 10,000 m, it can be seen that the thickness of the deposited sediments ranges from about 2.0 mm to 0.008 mm. Figures 73-79 are similar plots but for the spatial distribution of the maximum concentrations that occurred during the simulation in the vertical layer lying between 1.0 m and 2.0 m below the water surface. It can be seen that the maximum values range from about 350 mg/l to 20 mg/l from 250 m to 10,000 m along the centerline of the plume. Near-bottom (3-4 m) concentrations are presented in Figures 80-86. At the same locations along the centerline of the plume, the maximum concentrations ranged from about 1000 mg/l to 125 mg/l.

In all of the time series plots for all runs it can be seen that non-zero concentrations at a particular location only persist for a relatively short period. In addition, note that the maximum values on the time series plots are “spikes”. The average values of concentrations that occur at a particular location are much smaller.

Simulation 5 – 3 m Water Depth and 0.5*Flow Field

This simulation was identical to the one discussed above in 3 m of water except that the flow field presented in Figure 3 was multiplied by a factor of 0.5. Thus, since the shear stress is proportional to the velocity squared, the bottom shear stress was only one fourth of that in the previous simulation. Various distances from the trench along the centerline of the plume are shown in Figure 43.

Comparing Figures 87-93 with Figures 44-50, it can be seen that the thickness of deposition in this scenario ranges from about 0.34 mm to 0.00035 mm from 250 m to 10,000 m along the centerline of the plume, whereas, in the previous scenario it was about 1.0 mm to 0.0035 mm. In addition, one can see that with the velocity being one half of its previous value the plume barely extends past 10,000 m over the 10-day simulation. With the lower velocity (and thus lower shear stress), one would expect to see more deposition close to the source. At a distance of 250 m (compare Figures 87 and 44) this is not the case. The conclusion is that much more deposition, which is not evident in these plots, must be occurring immediately at the source. With the lower velocity,

particles aren't transported away from the source as fast, resulting in higher concentrations and thus higher rates of settling.

Comparing Figures 94-100 with Figures 51-57 and Figures 101-107 with Figures 58-64, it can be seen that the maximum concentrations of suspended sediment are less from 250 m to 10,000 m with the lower velocity. Therefore, the reason for the observed decreased deposition cannot be because more material is in the water column, but rather because much more material is deposited immediately adjacent to the trench.

RESULTS FROM DISPOSAL OF STOCKPILED MATERIAL

Zone 1 Disposal

A series of model runs were made for the Zone 1 disposal scenario. As previously noted, the 100,000 cu yd of stockpiled material was released into the water column over 24 hours. The disposal is represented by 12 line sources covering the disposal area, with disposal from each line source occurring over 2 hours at a rate of 4116 cu yd/hour. The first model run was made with the flow field shown in Figure 3 multiplied by a factor of 1.5. This is considered the base run. The percent of material suspended in the water column was taken to be 10%. The grain size distribution given in Table 2 for a water depth of 3 m was employed.

Figure 108 shows the location of the Zone 1 source and distances along the centerline of the plume. Figures 109-110 are plots of bottom thickness, with times series plots at 500 m and 5000 m away from the source. Figures 111-112 show the maximum water column concentrations of suspended sediment at mid-depth and near the bottom that occurred during the simulation. A times series plot at 5000 m is superimposed on each plot. Once again, when viewing the time series plots, one should keep in mind that, due to the randomness of each particle's movement, results can differ depending on the particular cell that is "clicked" upon.

Effect of Flow Field: Zone 1 disposal scenarios were also run to examine the effect of changing the velocity field presented in Figure 3. Figures 113-114 show the bottom deposition for the case where the flow field in Figure 3 is multiplied by a factor of 2.0, whereas, Figures 115-116 show results for the case of multiplying the flow field by a factor of 3.0. Comparing Figures 109-110 with 113-114 and with 115-116, it can be seen that more sediment is deposited at greater distances from the source when the flow field is increased by a factor of 2.0, but deposition decreases for the case of a factor of 3.0. To understand this behavior, one has to consider the bottom shear stress resulting from each flow field relative to the critical shear stresses for deposition contained in the settling algorithm of SSFATE. Using the following expression to compute the bottom shear stress:

$\tau = 0.003 \rho U^2$, where ρ is water density and U is the water velocity,

the bottom shear stress for the base case (factor=1.5) is about 0.006 Pa. Using factors of 2.0 and 3.0, the shear stress is about 0.01 Pa and .024 Pa, respectively. In these runs, the critical shear stress for deposition of the clay particles is 0.016 Pa. As the shear stress increases, the probability for deposition decreases. However, for the case of a factor of 2.0, deposition of clay particles still occurs since the shear stress is still below the critical value, and the larger velocity carries sediment farther away from the source before deposition occurs. For the case of using a factor of 3.0, particles are obviously carried farther away, but the shear stress from the flow field exceeds the critical shear stress for deposition of the clay particles. Thus, no deposition of the clay particles can occur, resulting in less overall deposition.

Figures 117-118 show mid-depth and near-bottom suspended sediment concentrations for the case of multiplying the flow field by a factor of 2.0, whereas, Figures 119-120 show similar results for the case of using a factor of 3.0. In all three cases, very little material is suspended at mid-depth. Comparing Figures 112, 118, and 120, it can be seen that as the flow velocity increases the near bottom concentrations increase. This is due to the fact that the increased bottom shear stress keeps material in suspension. Recall that no deposition of the clay particles occurs for the case of using a factor of 3.0.

Effect of Vertical Diffusion: Figures 121-124 show the effect of the vertical diffusion coefficient on model results for Zone 1 disposal. The only difference between scenarios represented by these figures and Figures 109-112 is that the vertical diffusion coefficient was increased from 0.000005 cm²/sec to 0.00039 cm²/sec. The larger value was calculated from the following expression for turbulent flow:

$D_z = 0.06 H U^*$, where U^* is the friction velocity and H is the water depth.

The decision to run most of the SSFATE simulations with a value of 0.000005 cm²/sec is based on the assumption that the flow under the ice is not very turbulent. In addition, seawater under ice tends to be stratified, reducing vertical turbulence. This value is still about ten times the molecular value.

Comparing Figures 109-110 with 121-122 indicates that the model computes greater deposition with the increased vertical diffusion. An explanation for this observation is that with the higher vertical diffusion there is much more up and down movement of the particles in the water column due to the random walk procedure (see Appendix A). Evidently this movement results in more particles hitting the bed, resulting in more deposition. Comparing Figures 111 and 123, it can be seen that the increased vertical diffusion coefficient results in increased maximum concentrations of suspended sediment at mid-depth due to the increased movement of particles up and down in the water column. Maximum concentrations near the bottom (see Figures 112 and 124) at a particular location are also higher with the increased movement of the particles in the water column.

Effect of Critical Shear Stresses: Figures 125-128 show the impact of the critical shear stresses in the settling algorithm in SSFATE. The initial values of the various critical shear stresses for deposition for different grain size classes were presented in Table 3. The values used for the results presented in Figures 125-128 are given in Table 5.

Table 5. Increased values of critical shear stresses (in Pascals)

<u>Class</u>	<u>τ_{cl}</u>	<u>τ_{ul}</u>
Clay	0.06	0.12
Fine Silt	0.12	0.24
Coarse Silt	0.24	0.50
Fine Sand	0.50	0.90

Comparing Figures 115-116 with Figures 125-126, it can be seen that increasing the values for the critical shear stresses for deposition results in increased deposition since the shear stress computed from the flow field always falls below the critical values. Likewise, comparing Figures 119-120 with Figures 127-128 shows that the concentrations of suspended sediment are lower due to the increased deposition of sediment particles.

It can be seen that the values of the parameters in the settling algorithm can greatly influence model results. As previously discussed, generally these values are highly site dependent and should be determined from tests on sediment collected at the site using water from the site.

Zone 2 Disposal

Zone 2b is located along the lower portion of the pipeline, with material placed immediately adjacent to the pipeline (see Figure 4). The total amount of stockpiled material was 10,000 cu yd, and, as for Zone 1 disposal, the time for release of the material to the water column was 24 hours. Thus, the line source had a release rate of 417 cu yd/hour. The characteristics of the material and the percent of sediment suspended were the same as for Zone 1 in a water depth of 3m. The flow fields employed were 1.5, 2.0, and 3.0 times the flow field shown in Figure 3.

Figure 129 shows the location of various distances along the path of the suspended sediment plume away from the source. Results are presented only at 5000 m from the source along the centerline of the plume. Figures 130-132 show the bottom thickness and maximum concentrations of suspended sediment at mid-depth and near the bottom. These results are for the case of using a factor of 1.5 times the flow field in Figure 3, a vertical diffusion coefficient of $0.000005 \text{ cm}^2/\text{sec}$, and the values for the critical shear stresses presented in Table 3.

Effect of Flow Field: Model results for the case of using a factor of 2.0 times the flow field are shown in Figures 133-135. Other parameters / coefficients were the same as for results presented in Figures 130-132. Results for the case of using a factor of 3.0 are

presented in Figures 136-138. Comparing the bottom deposition plots (see Figures 130, 133, and 136), it can be seen that there is very little difference between using a factor of 1.5 and 2.0. However, when the flow field is increased by a factor of 3.0, there is less deposition near the source and more at 5000 m from the disposal line. With the increased velocities, particles move away from the source faster, resulting in a lower concentration near the source which results in a lower settling velocity. Thus, there is less deposition near the source. Although clay particles are never deposited for a factor of 3.0 since the shear stress is greater than the critical shear stress for deposition for clay, evidently many more of the particles representing the silt fractions are swept away in sufficient quantity to result in increased overall deposition at 5000 m.

Figures 131-132, 134-135, and 137-138 show computed suspended sediment concentrations at mid-depth and near-bottom for factors of 1.5, 2.0, and 3.0, respectively. Very few particles are transported in the upper water column at a location 5000 m away from the source for all three cases (see Figures 131, 134, and 137). However, Figures 132, 135, and 138 show that maximum occurring concentrations near the bottom increase as the ambient velocity increases. The higher velocity sweeps more particles away from the line source.

Effect of Vertical Diffusion: Figures 139-141 show the impact of increasing the vertical diffusion coefficient from $0.000005 \text{ cm}^2/\text{sec}$ to $0.00039 \text{ cm}^2/\text{sec}$. The reason for the selection of these values has been discussed above. Comparing Figures 139 and 130, it can be seen that there is a little less deposition near the line source for the higher diffusion coefficient and a little more away from the source. The time series plots at 5000 m actually show less deposition for the higher value of the critical diffusion. However, keep in mind the randomness of the transport of particles.

Comparing Figures 131-132 with Figures 140-141, the impact of the increased vertical diffusion coefficient on suspended sediment concentrations from the Zone 2 disposal can be seen. At mid-depth, the higher value results in much higher maximum concentrations since there is much more up and down movement of the sediment particles. There is no substantial difference between the spatial distribution plots of near-bottom maximum concentrations, although, the increased movement of the particles vertically (higher coefficient) appears to result in slightly lower maximum concentrations.

Effect of Shear Stresses: Figures 142-144 show the impact of using the higher critical shear stresses in Table 5. Comparing Figures 136 and 142, it can be seen that the deposition increased at 5000 m from the source. Figures 137 and 143 show that the suspended sediment concentrations at mid-depth are about the same. However, with the increased deposition resulting from the higher shear stresses, the concentrations near the bottom decreased (see Figures 138 and 144).

SUMMARY AND CONCLUSIONS

Summary

A recently developed numerical model called SSFATE has been applied to simulate suspended sediment plumes resulting from dredging activities associated with the Liberty Island Project. These activities include the excavation and backfilling of a trench for laying the pipeline and return of stockpiled sediment to the water column during spring ice breakup. No field data were available for validation of the model. In addition, no sediment data were available to aid in setting settling parameters. These caveats should be acknowledged in interpreting the model results.

Four separate simulations using water depths of 1, 2, 3, and 4 m, with the location of the sediment source located at different distances along the proposed path of the pipeline, were made to simulate the complete trenching project. In each simulation, the dredging of material was assumed to occur for 5 days, with the simulation continuing for another 5 days. The percent of fine-grained material and the percent of material suspended in the water column were varied based on the water depth. A flow field was constructed based on best-available data, which were limited to ADCP time series profiles at an offshore station. These data were used to construct uniform flow fields with residual water velocity under the ice cover assumed to be about 3-4 cm/sec and directed toward the northwest.

The stockpiled material not used for backfilling was placed at two locations. Material placed in Zone 1 covered about 230 acres. This disposal scenario was modeled by a series of 12 lines, with disposal occurring along each line for 2 hours for a total disposal period of 24 hours. The disposal operation in Zone 2b was simulated as a line source, with disposal taking place over 24 hours. As in the trenching simulations, the simulations continued for 5 days after the release of material to the water column stopped. The water depth was assumed to be 3 m for each simulation. Characterization of the material was the same as that specified in the 3 m trenching simulation. The percent of sediment suspended was assumed to be 10%.

Model results include animation of particles representing the sediment released into the water column, spatial distribution of concentrations at different water depths, spatial distribution of material deposited on the bottom, and time series plots of water column concentrations and bottom deposition.

Conclusions

Features of the SSFATE numerical modeling system were demonstrated to be adaptable to Liberty Island pipeline construction scenarios. Given adequate information on environmental conditions (e.g., flow velocity; spatial and temporal scales of the dredging or trenching operation; production rate of dredging; and grain size and settling characteristics of in situ sediments and those released to the water column), SSFATE can provide managers of dredging projects valuable information on the spatial and temporal distribution of suspended sediment concentrations and the spatial distribution of deposited sediments.

In the Liberty Island application, best-available data were used to construct model scenarios, adopting a conservative approach where assumptions were based on minimal site-specific field data. Thus, when viewing these model results, it should be noted that the computed suspended sediment concentrations are likely conservative. One salient limitation in the data used to construct scenarios was the paucity of information on the flow fields under the ice. In all SSFATE runs the flow field was assumed to be directed toward the northwest, while in reality intermittently that is not the case. In addition, assumptions of the percentages of excavated material released to the water column are likely conservative, i.e. somewhat higher than would actually occur.

The authors of this report present the modeling results with no attempt to interpret them with respect to the probability of impacts to resources in the proposed project area. That interpretation can only be done through an integration of knowledge pertaining to responses of specific resources (e.g., kelp) to exposures to suspended and deposited sediments, and is beyond the scope of this report. However, fully acknowledging the multiple assumptions upon which SSFATE input parameters were based for the present application, the authors do believe that SSFATE provides fundamentally sound first order predictions of temporal scales and magnitudes of those exposures. SSFATE results reported herein have not been validated, which necessarily involves comparisons of predicted and observed values at known points in the model domain under known sets of conditions (i.e. during construction activities). Should additional field data become available indicating major violations of our inherent assumptions (e.g., hydrodynamics with shifted direction or velocity components; substantially different source terms based on actual field measurements), we suggest that it would be highly desirable to refine the model scenarios to reflect those data.

REFERENCES

1. BP Exploration (Alaska), Inc. July 2000. "Liberty Development Project – Development and Production Plan – Revision 2."
2. Nakai, O. 1978. "Turbidity Generated by dredging Projects, Management of Bottom Sediments Containing Toxic Substances," Proceedings of the Third United States-Japan Experts Meeting, EPA-600/3-78-084, p. 31-47.
3. U.S. Army Corps of Engineers, Alaska District. May 2000. "Appendix G Section 404(b)(1) Evaluation 6-981109 Foggy Island Bay 1, Liberty Development Project."

APPENDIX A

Concentration Data

Bulk Material

Bottom Thickness

Bottom Thickness

0 -> .001	
.001 -> .002	
.002 -> .003	
.003 -> .004	
.004 -> .005	
.005 -> .006	
.006 -> .007	
.007 -> .008	
.008 -> .009	
.009 -> .01	
.01 -> .02	
.02 -> .03	
.03 -> .04	
.04 -> .05	
.05 -> .06	
.06 -> .07	
.07 -> .08	
.08 -> .09	
.09 -> .1	
.1 -> 1	
1 -> 5	
5 -> 10	
10 -> 25	
25 -> 50	

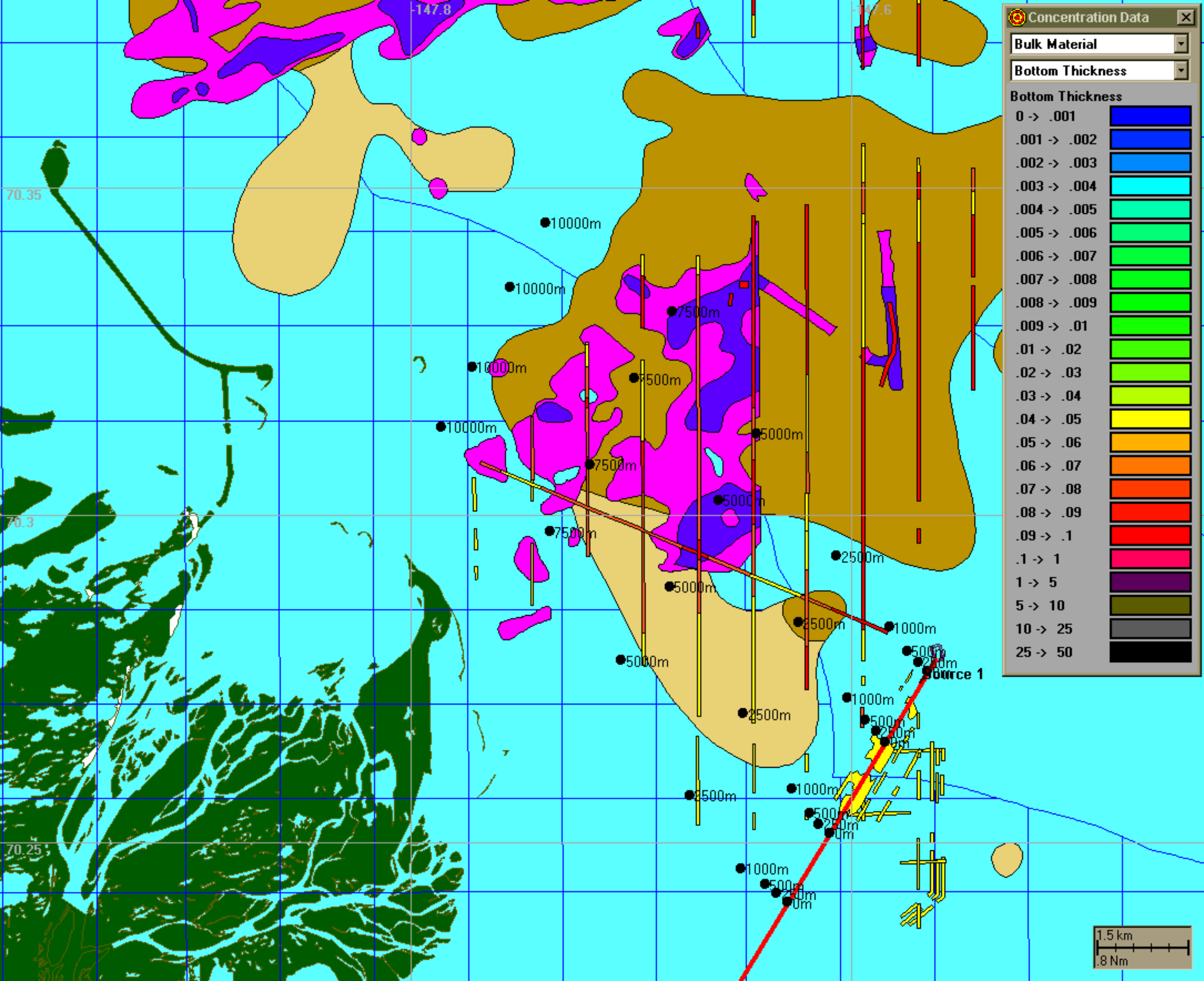

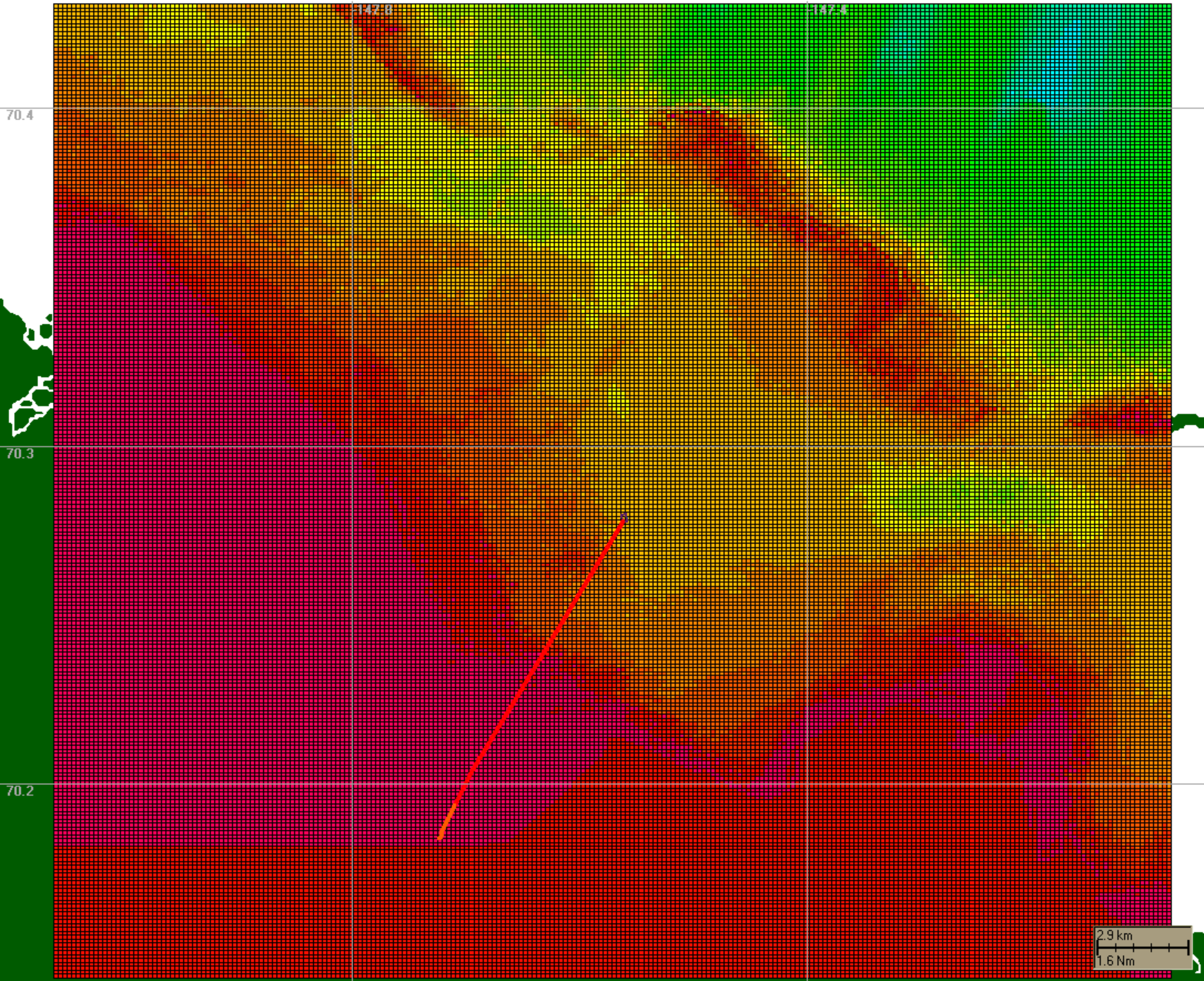

70.4

70.3

70.2

147.8

147.4

2.9 km
1.6 Nm

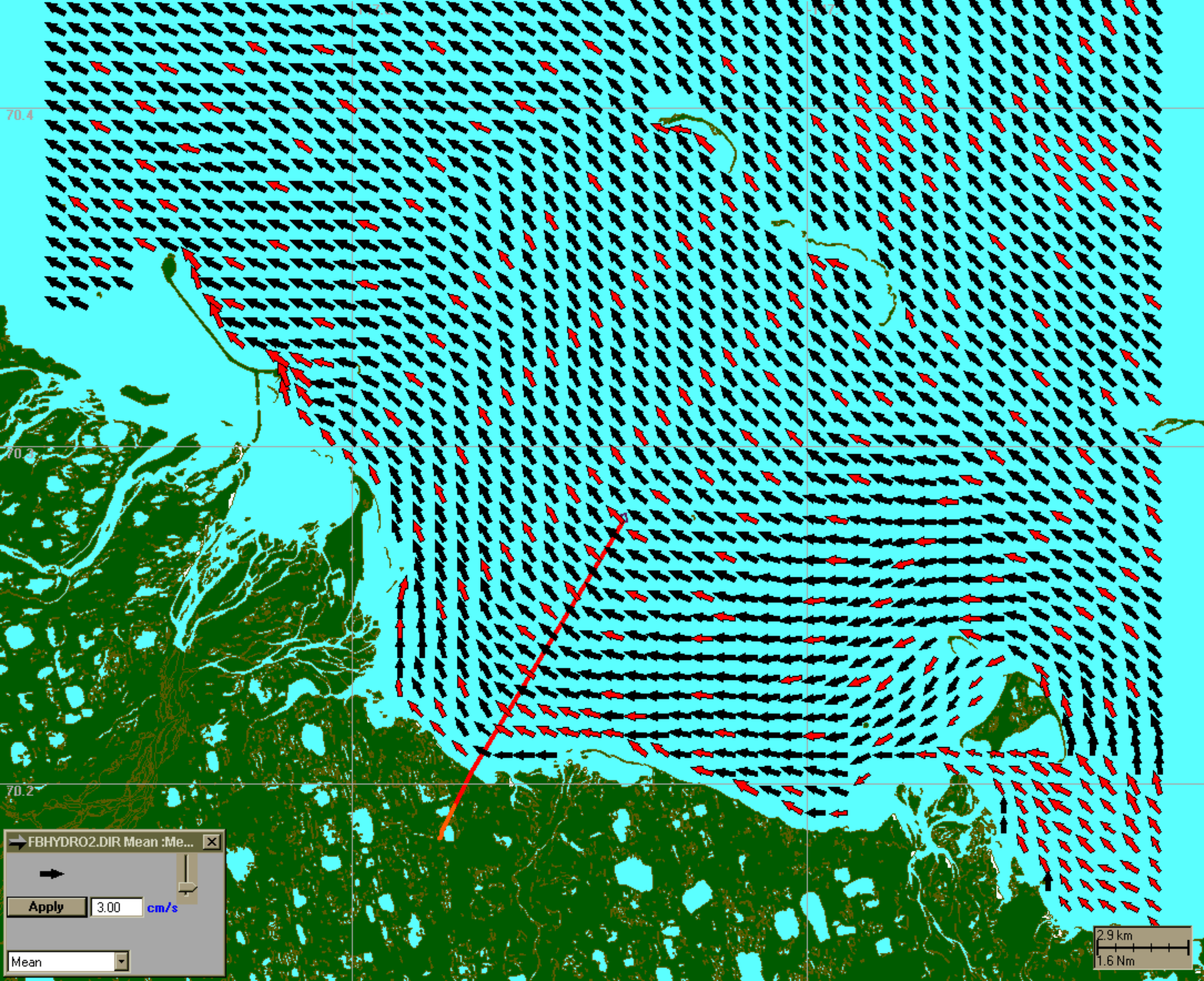

70.4

70.3

70.2



15.0

15.1

15.2

15.3

FBHYDRO2.DIR Mean :Me...

Apply cm/s

Mean

2.9 km
1.6 Nm

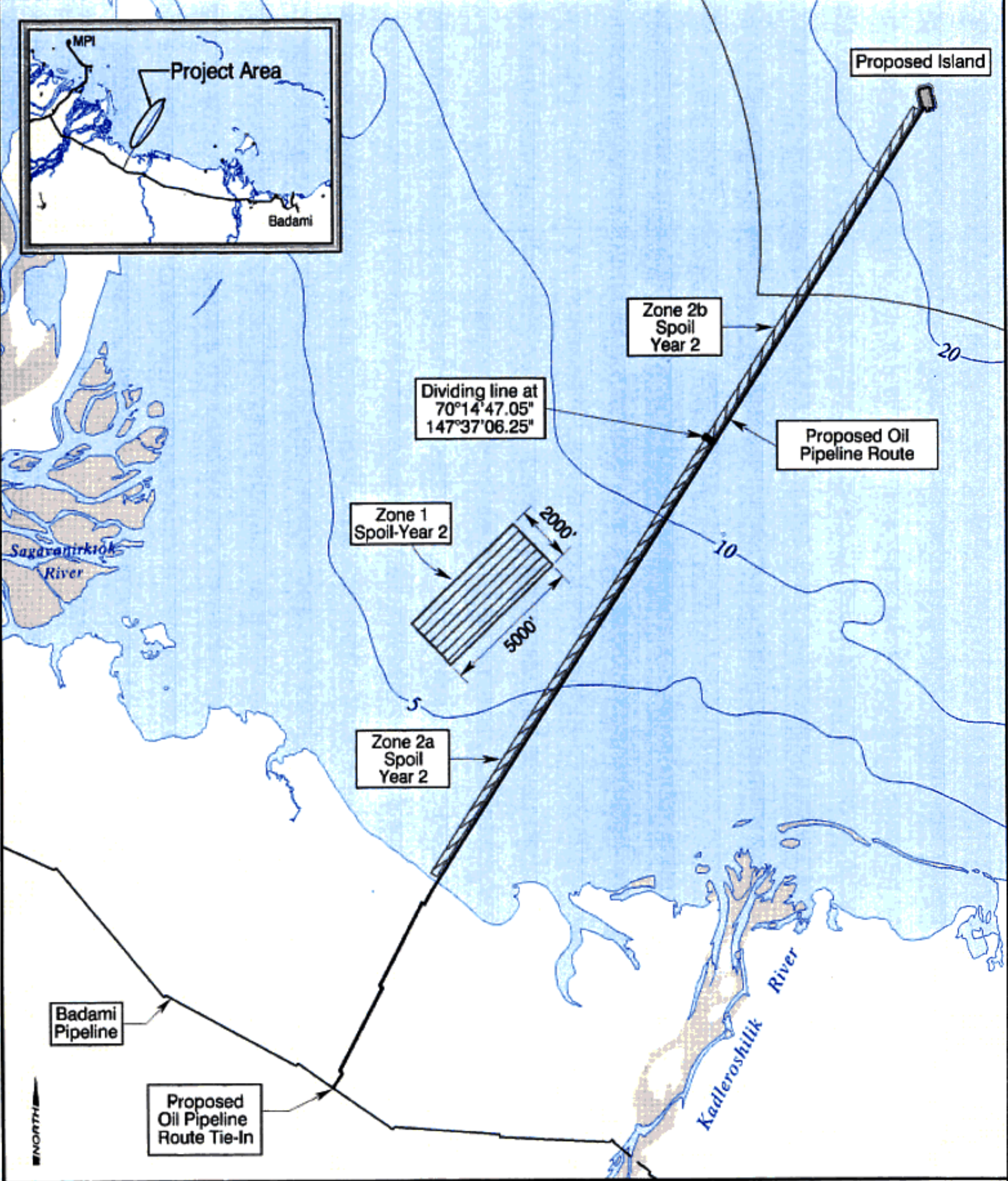
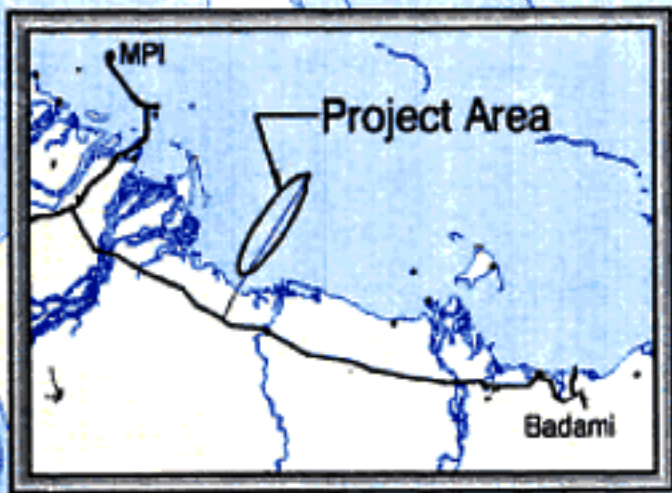

BP EXPLORATION (ALASKA) INC.

**LIBERTY DEVELOPMENT PROJECT
PROPOSED DREDGED MATERIAL
SITES ZONES 1 & 2**

DATE:
Rev. April 2000

SCALE:
1" = 5,000 Feet

FIGURE:
8-2

Bulk Material

Bottom Thickness

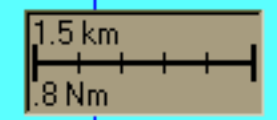
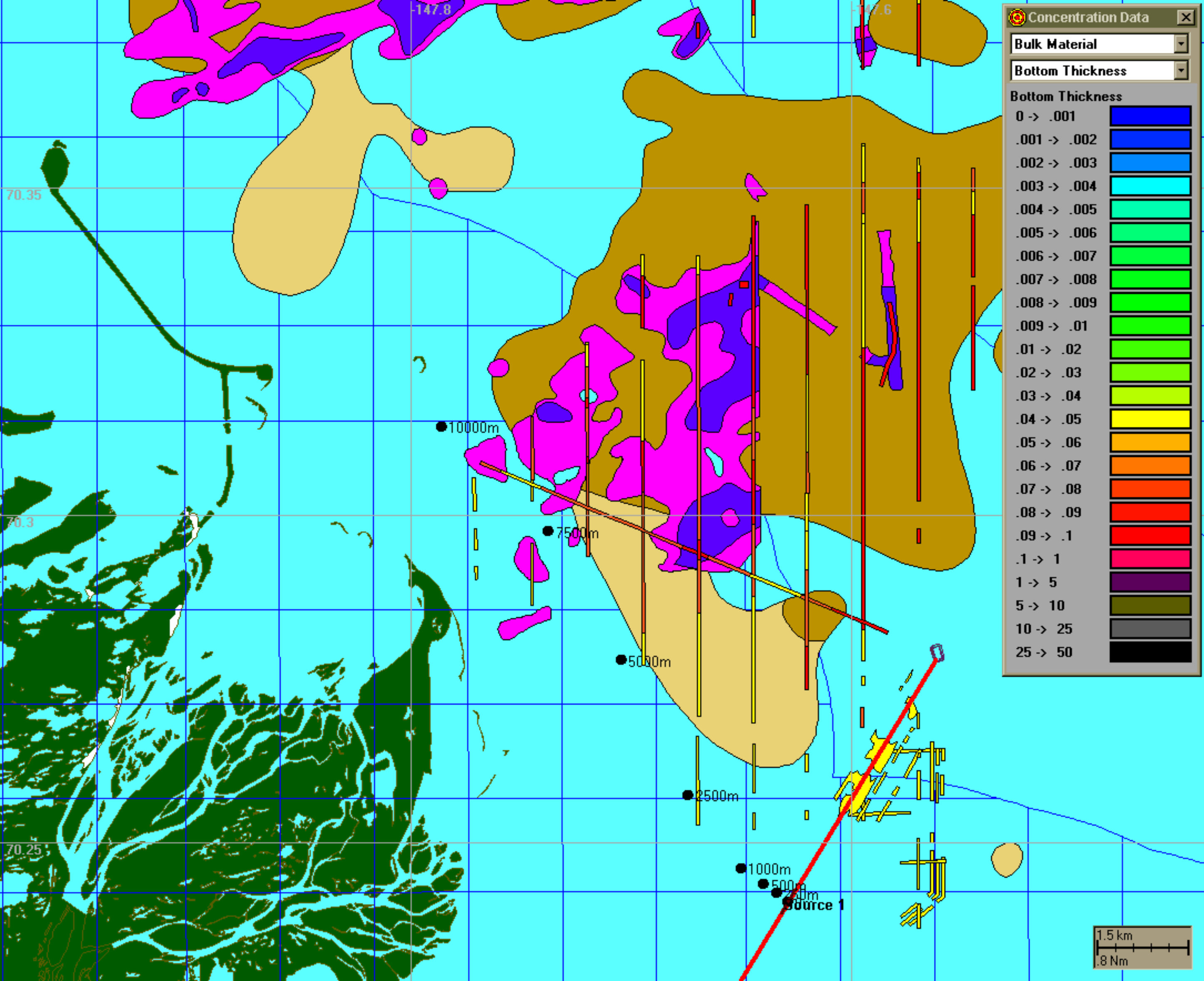
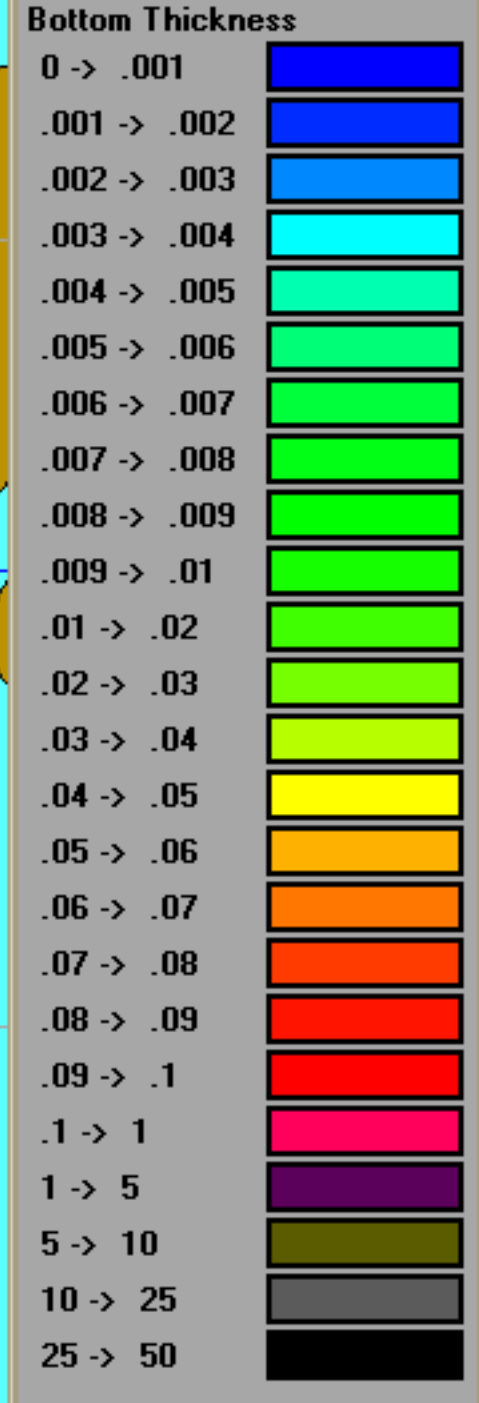

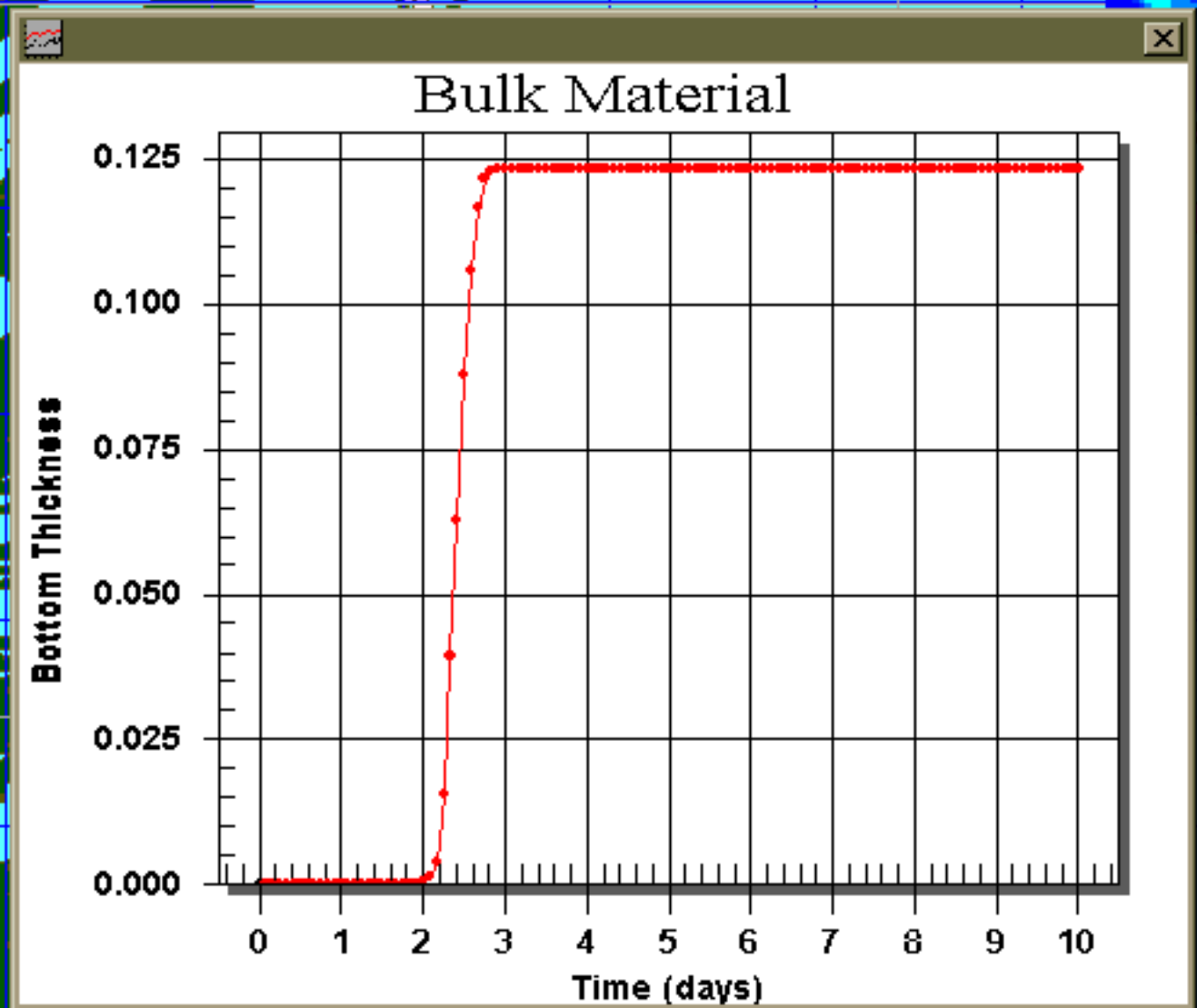
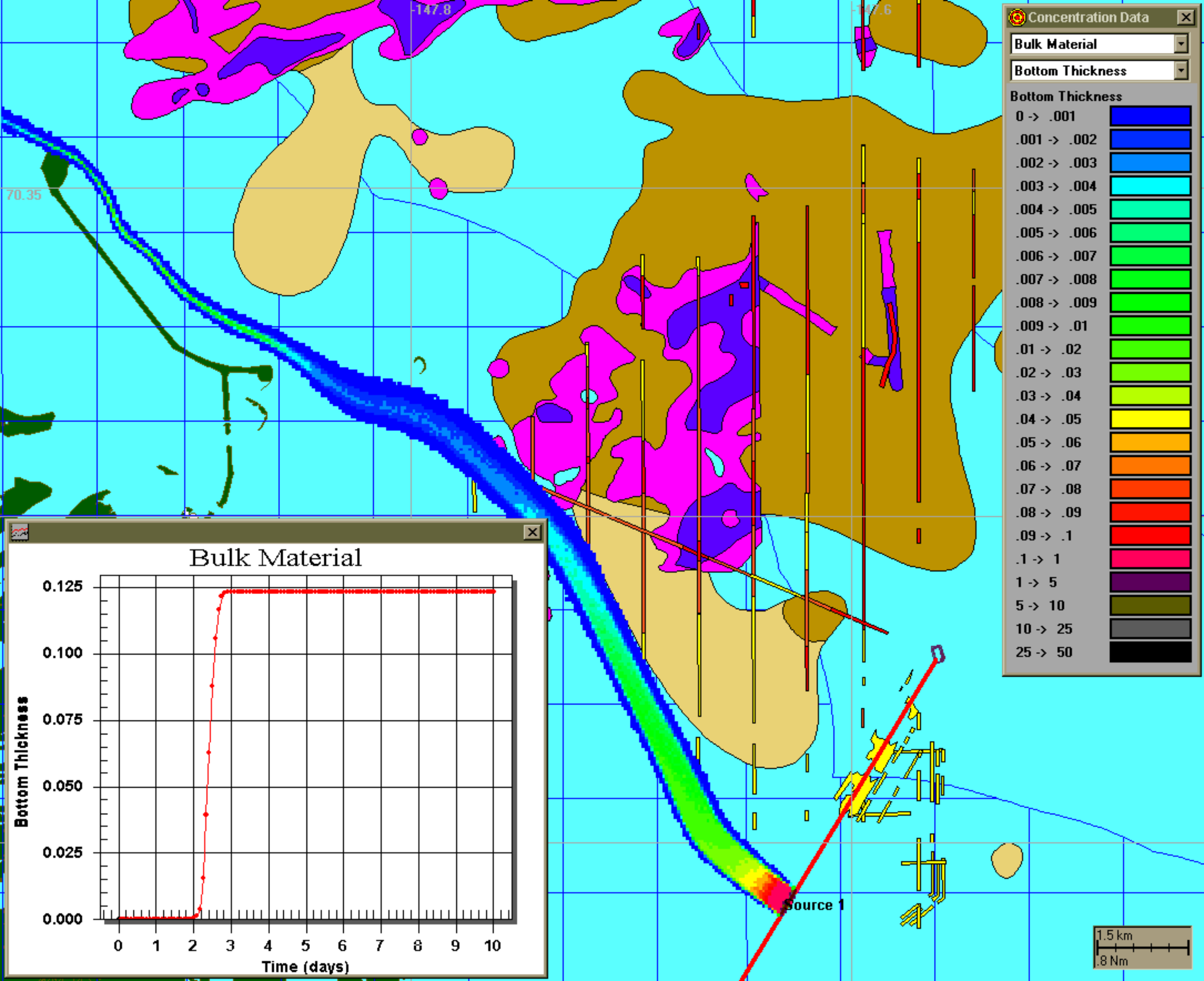

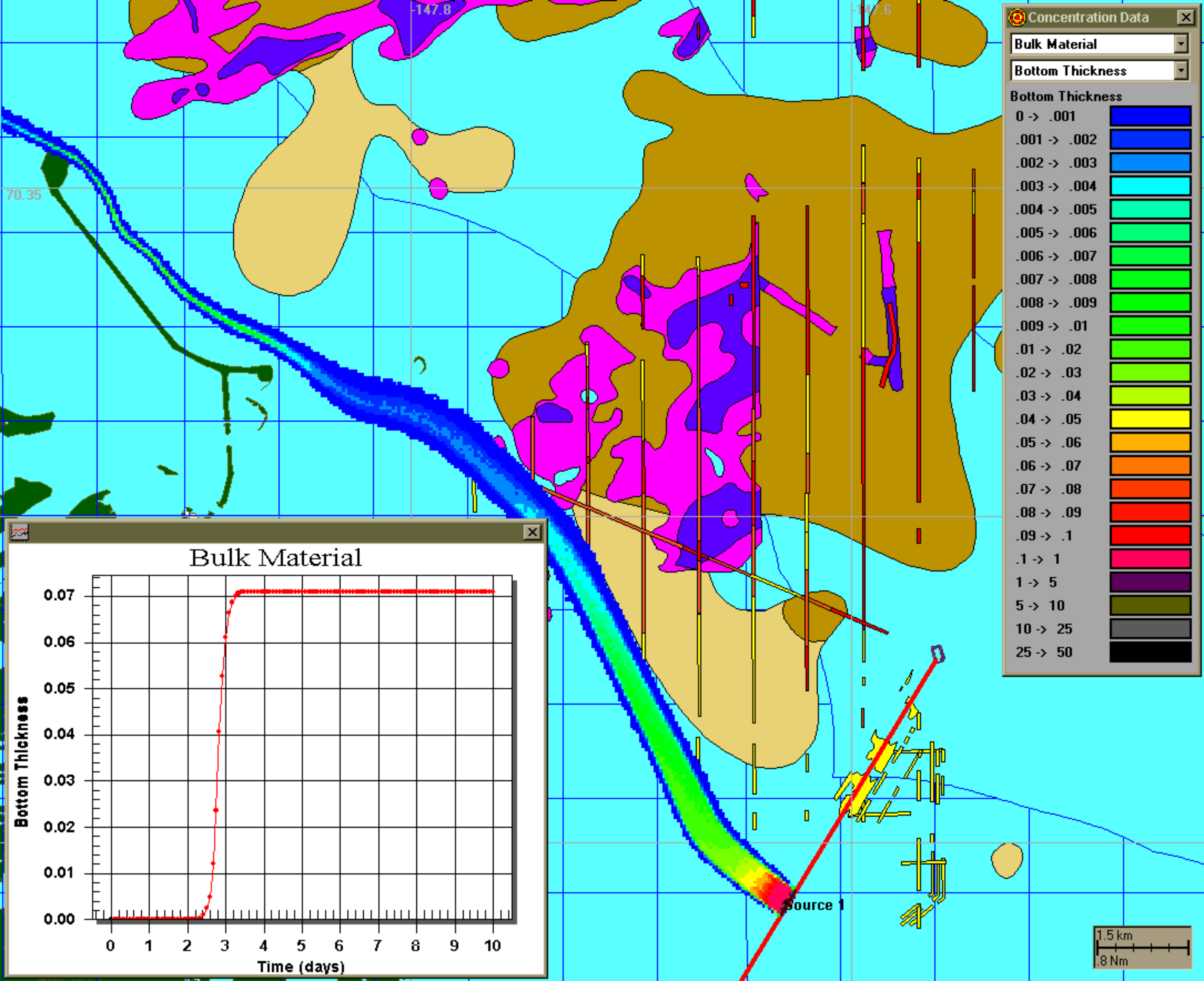

Concentration Data

Bulk Material

Bottom Thickness

Bottom Thickness

0 -> .001	[Dark Blue]
.001 -> .002	[Blue]
.002 -> .003	[Light Blue]
.003 -> .004	[Cyan]
.004 -> .005	[Green-Cyan]
.005 -> .006	[Green]
.006 -> .007	[Light Green]
.007 -> .008	[Green]
.008 -> .009	[Light Green]
.009 -> .01	[Green]
.01 -> .02	[Light Green]
.02 -> .03	[Yellow-Green]
.03 -> .04	[Yellow]
.04 -> .05	[Light Orange]
.05 -> .06	[Orange]
.06 -> .07	[Red-Orange]
.07 -> .08	[Red]
.08 -> .09	[Dark Red]
.09 -> .1	[Red]
.1 -> 1	[Magenta]
1 -> 5	[Purple]
5 -> 10	[Olive Green]
10 -> 25	[Grey]
25 -> 50	[Black]

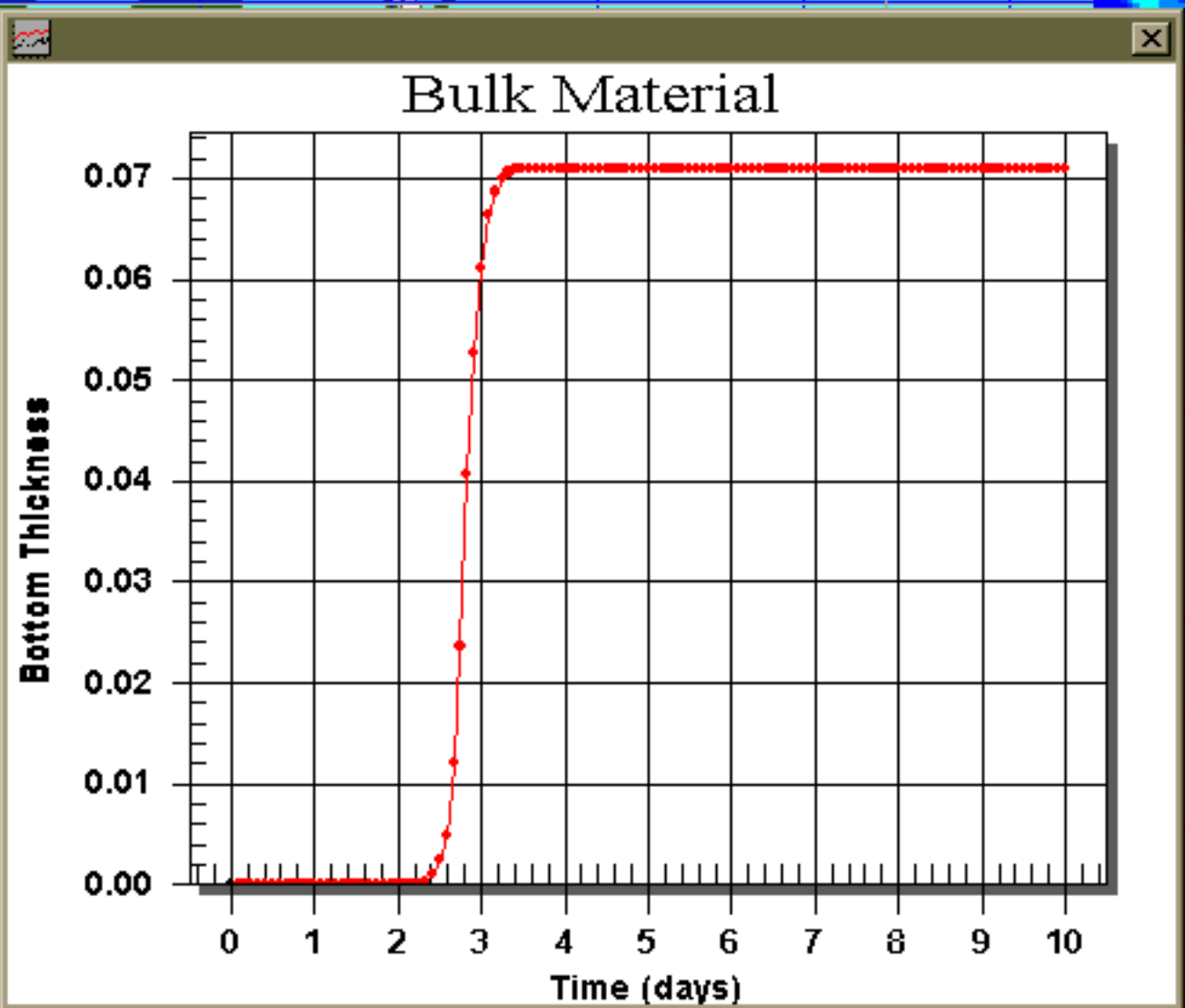

1.5 km
0.8 Nm

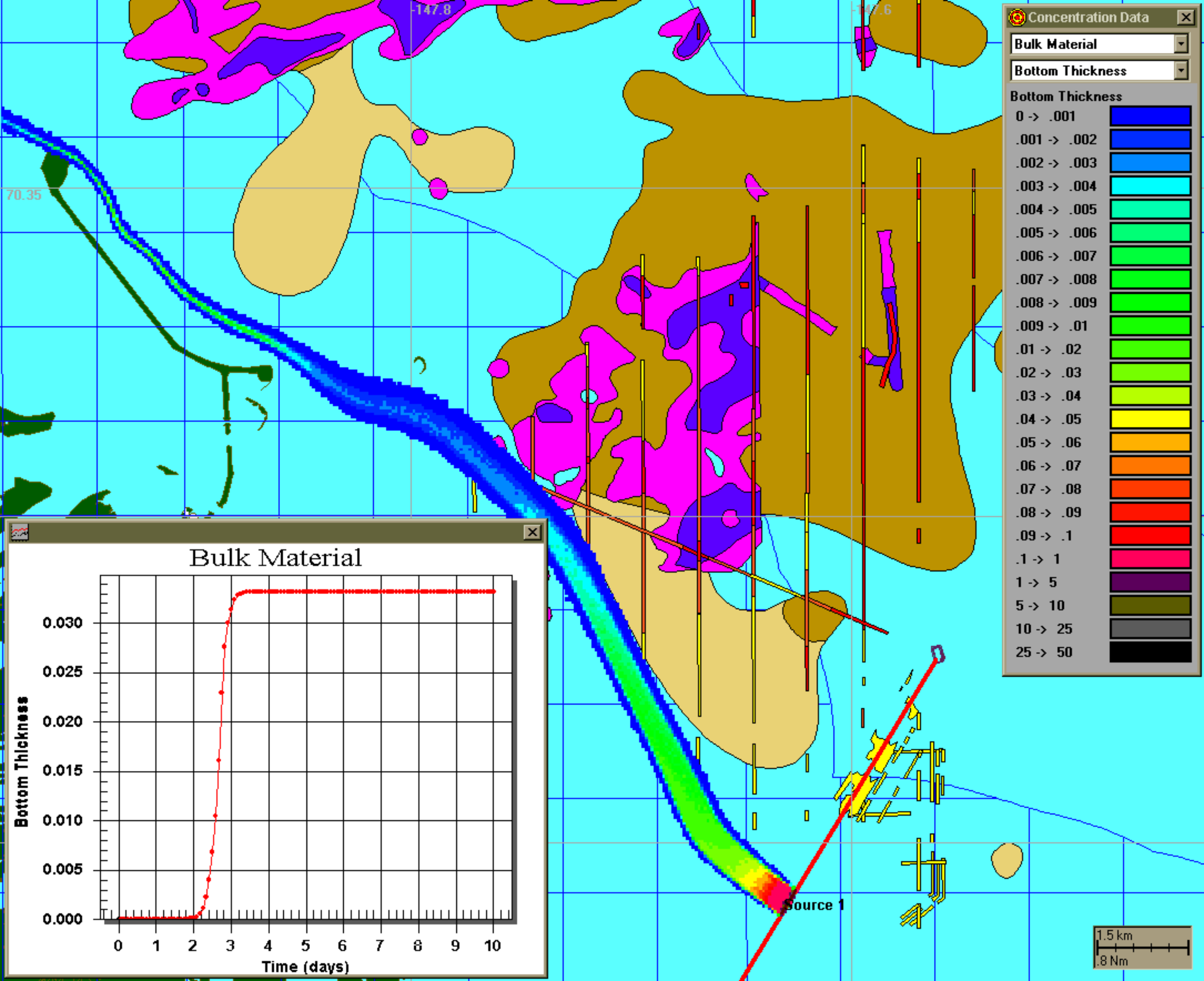

Concentration Data

Bulk Material

Bottom Thickness

Bottom Thickness

0 -> .001	
.001 -> .002	
.002 -> .003	
.003 -> .004	
.004 -> .005	
.005 -> .006	
.006 -> .007	
.007 -> .008	
.008 -> .009	
.009 -> .01	
.01 -> .02	
.02 -> .03	
.03 -> .04	
.04 -> .05	
.05 -> .06	
.06 -> .07	
.07 -> .08	
.08 -> .09	
.09 -> .1	
.1 -> 1	
1 -> 5	
5 -> 10	
10 -> 25	
25 -> 50	

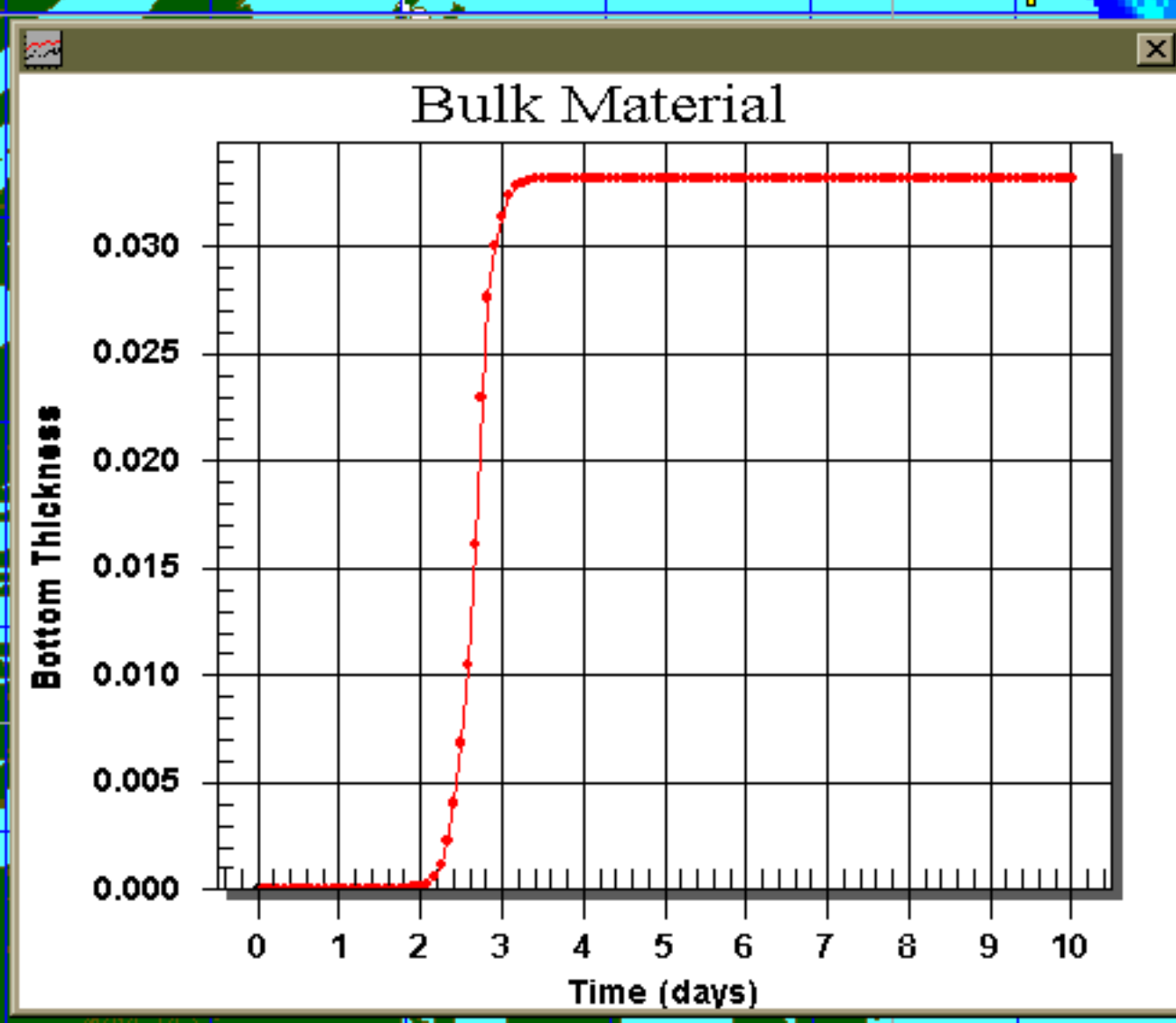

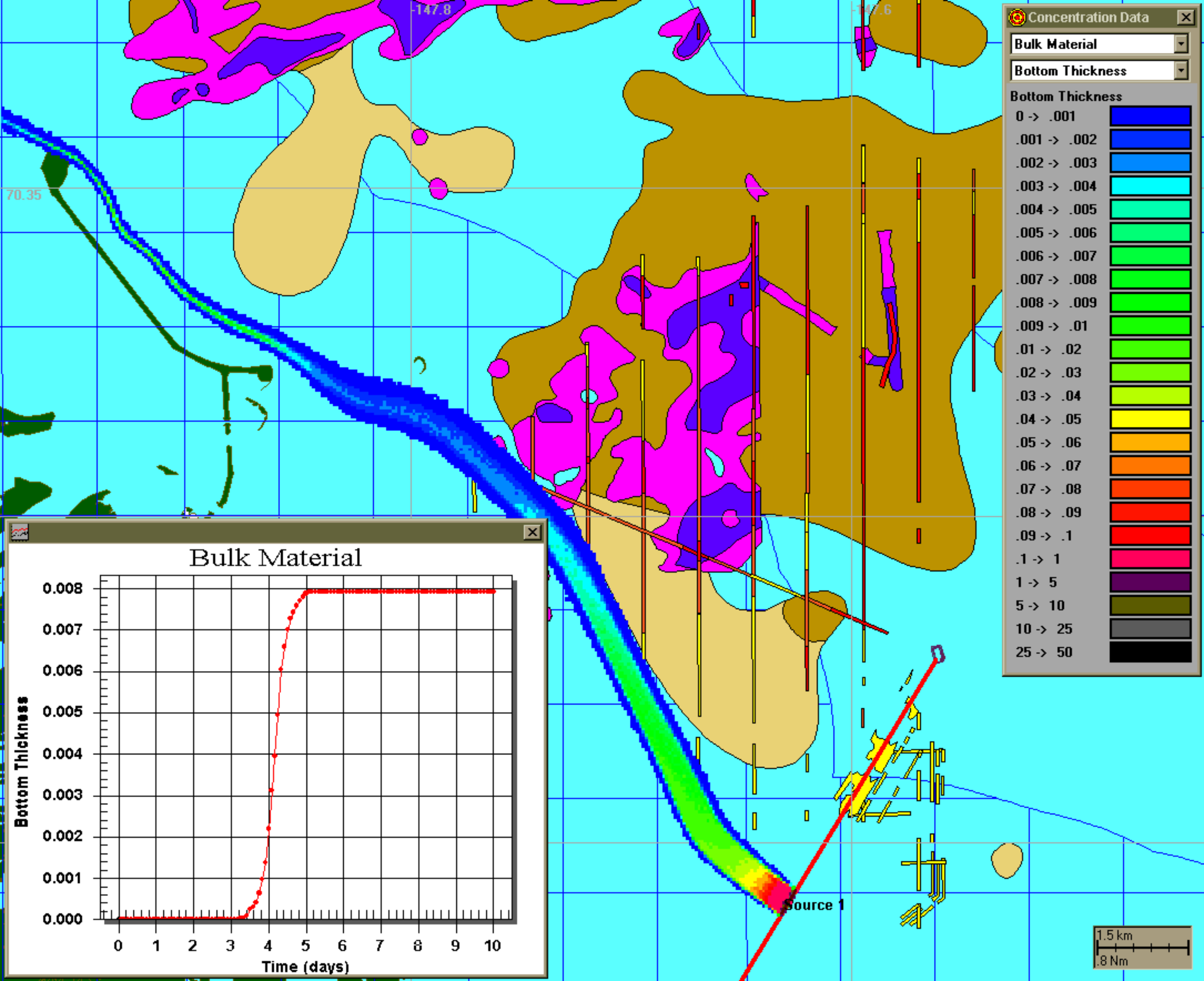

70.35

-147.8

-147.6

Bulk Material

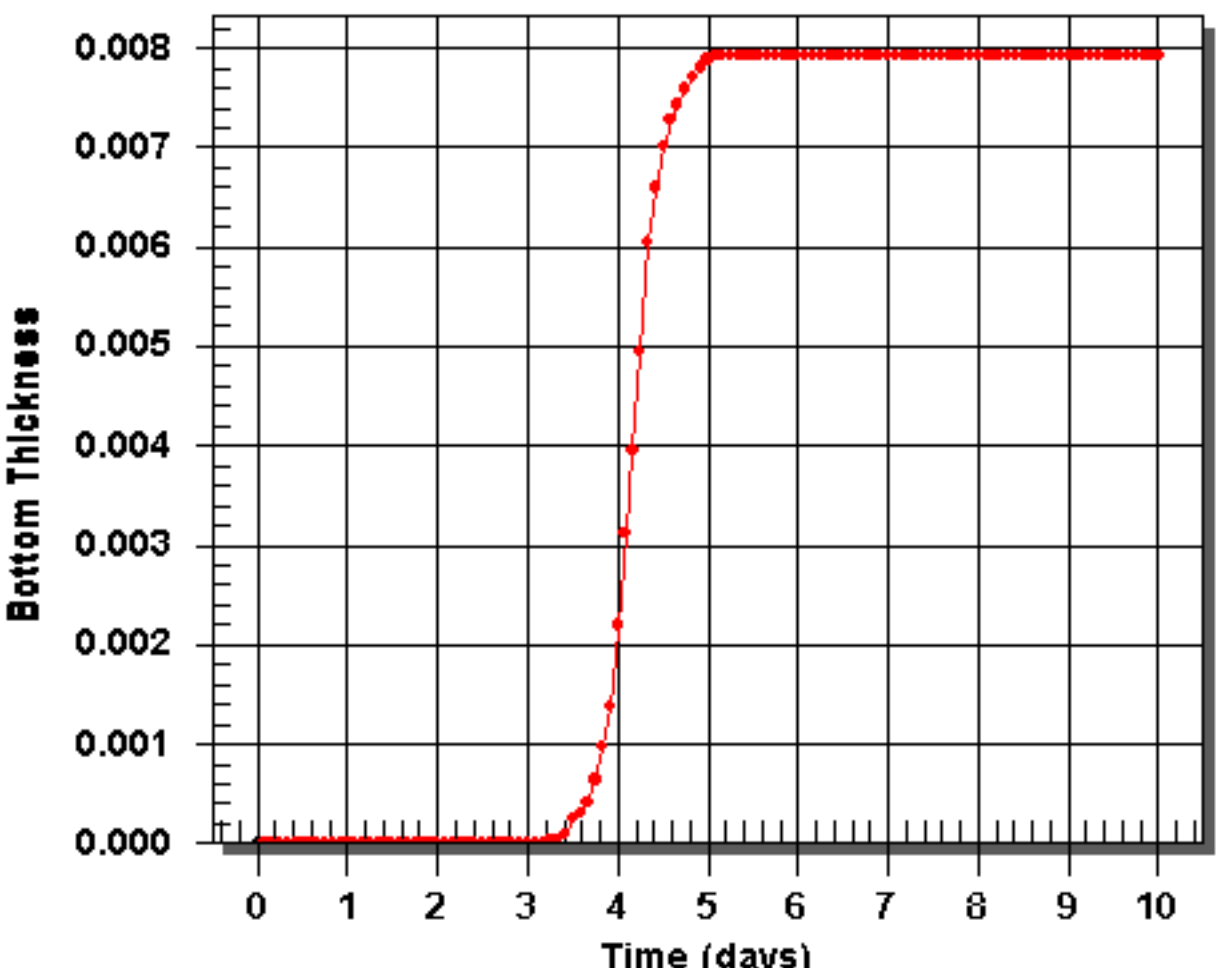

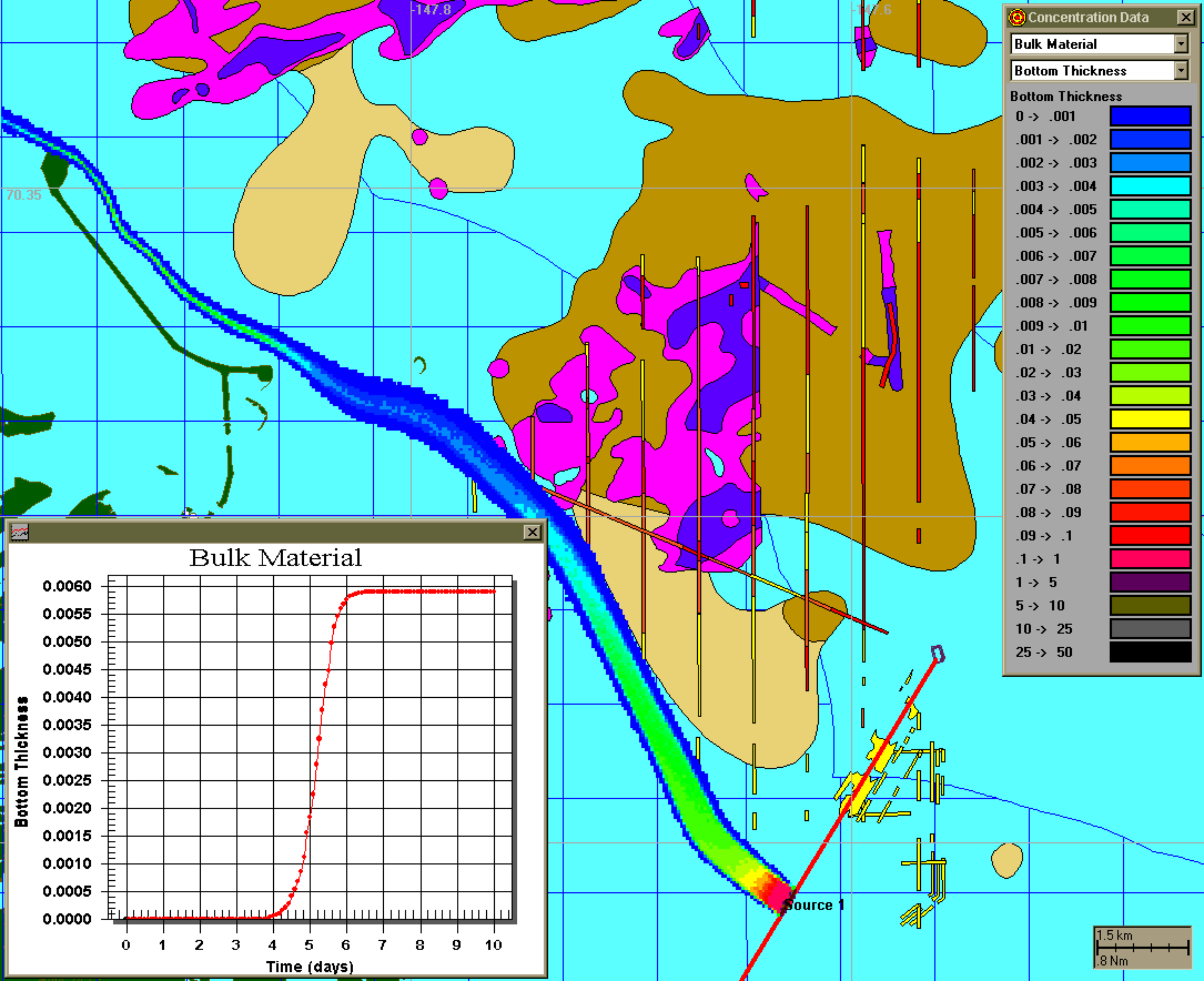

Bulk Material

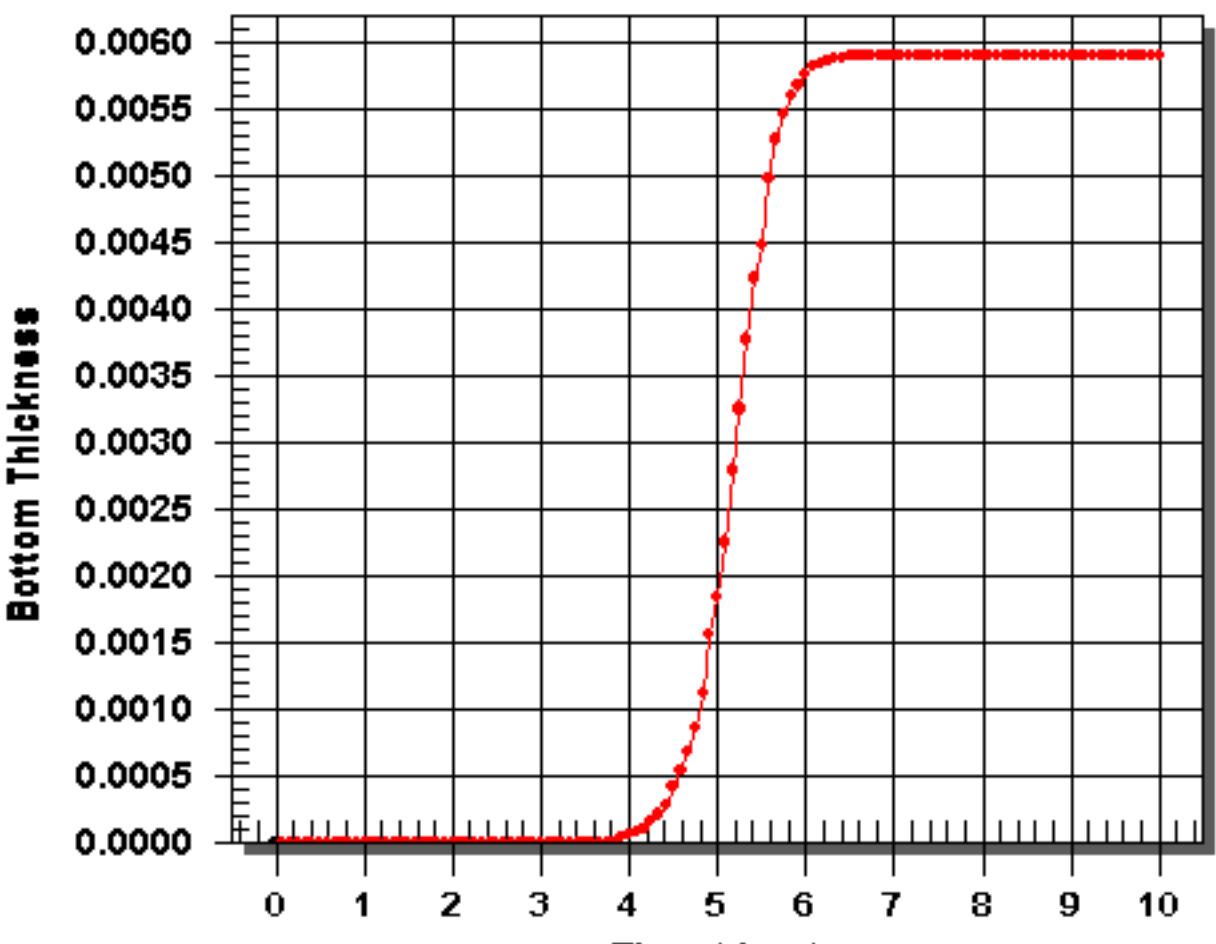

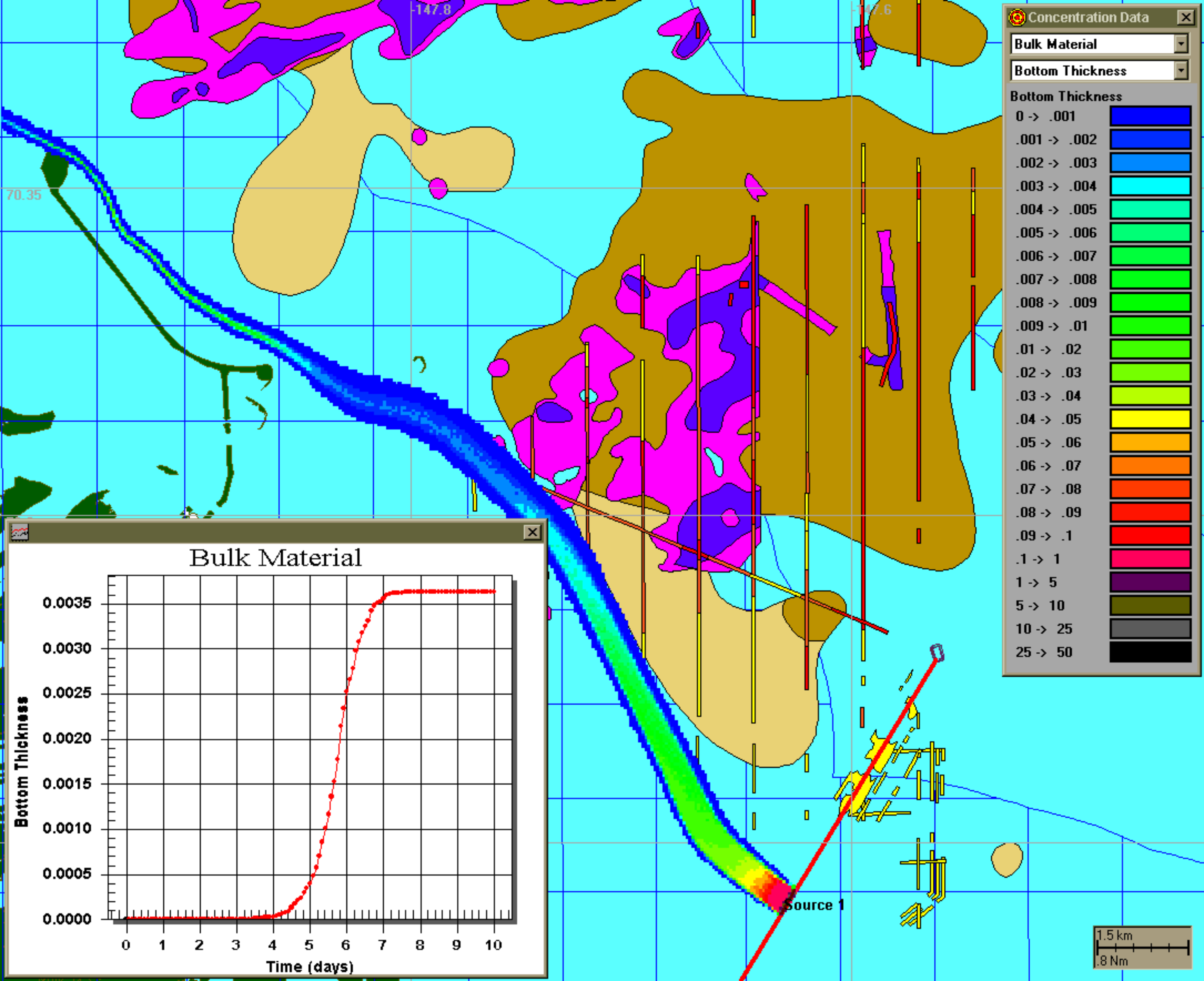

Concentration Data

Bulk Material

Bottom Thickness

Bottom Thickness

0 -> .001	[Dark Blue]
.001 -> .002	[Blue]
.002 -> .003	[Light Blue]
.003 -> .004	[Cyan]
.004 -> .005	[Green-Cyan]
.005 -> .006	[Green]
.006 -> .007	[Light Green]
.007 -> .008	[Green]
.008 -> .009	[Light Green]
.009 -> .01	[Green]
.01 -> .02	[Light Green]
.02 -> .03	[Yellow-Green]
.03 -> .04	[Yellow]
.04 -> .05	[Orange-Yellow]
.05 -> .06	[Orange]
.06 -> .07	[Red-Orange]
.07 -> .08	[Red]
.08 -> .09	[Dark Red]
.09 -> .1	[Red]
.1 -> 1	[Magenta]
1 -> 5	[Purple]
5 -> 10	[Dark Purple]
10 -> 25	[Grey]
25 -> 50	[Black]

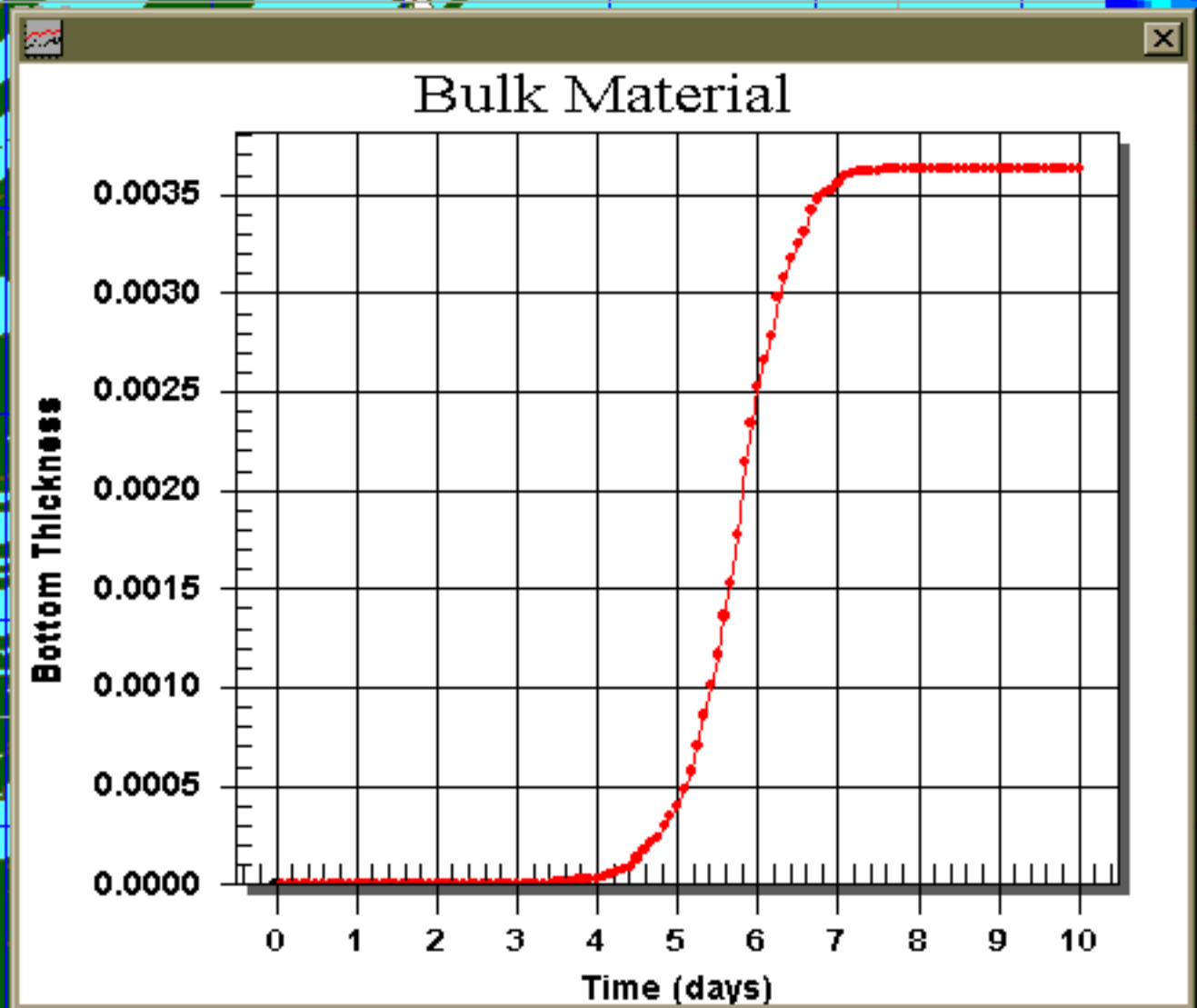

1.5 km
0.8 Nm

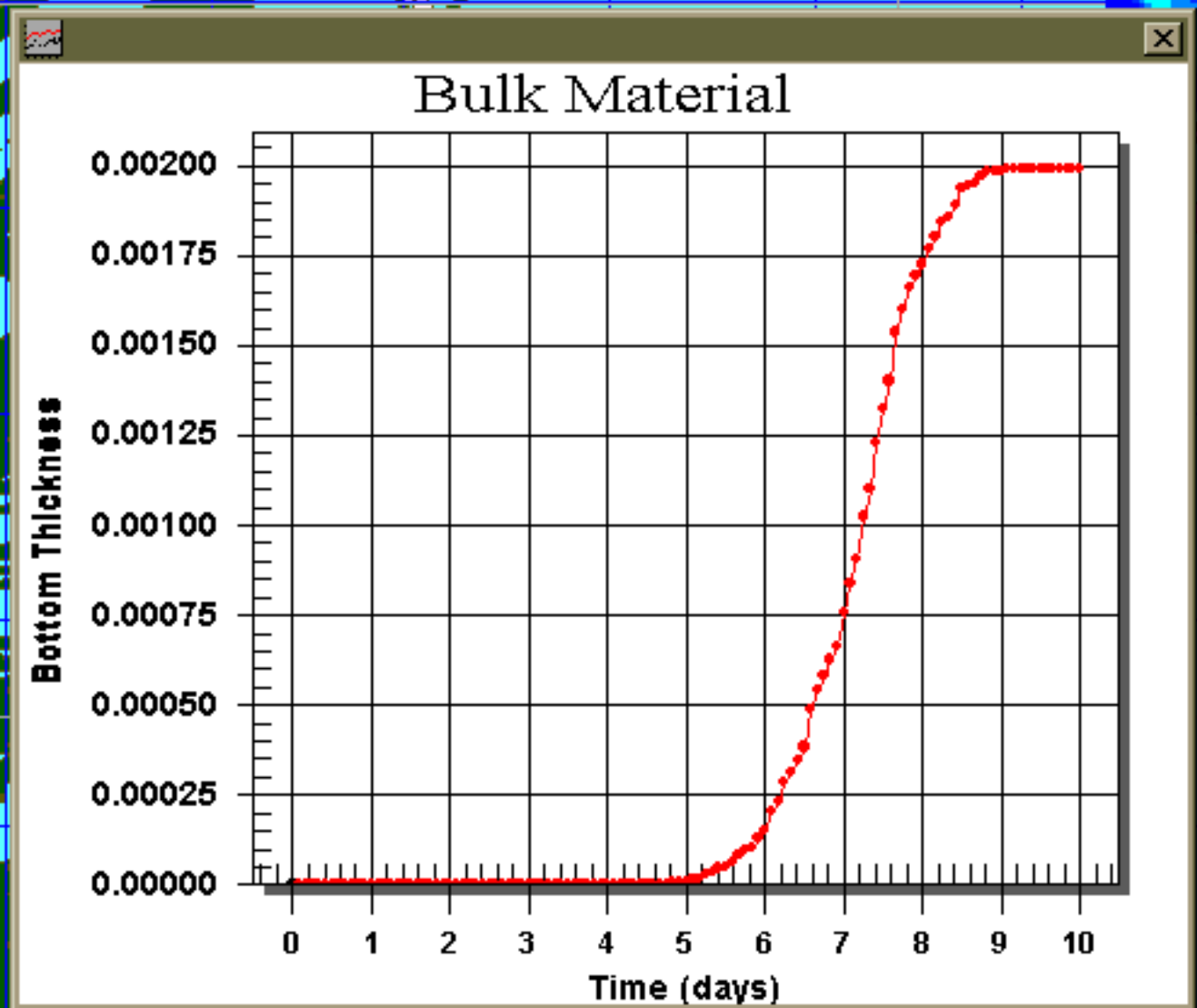
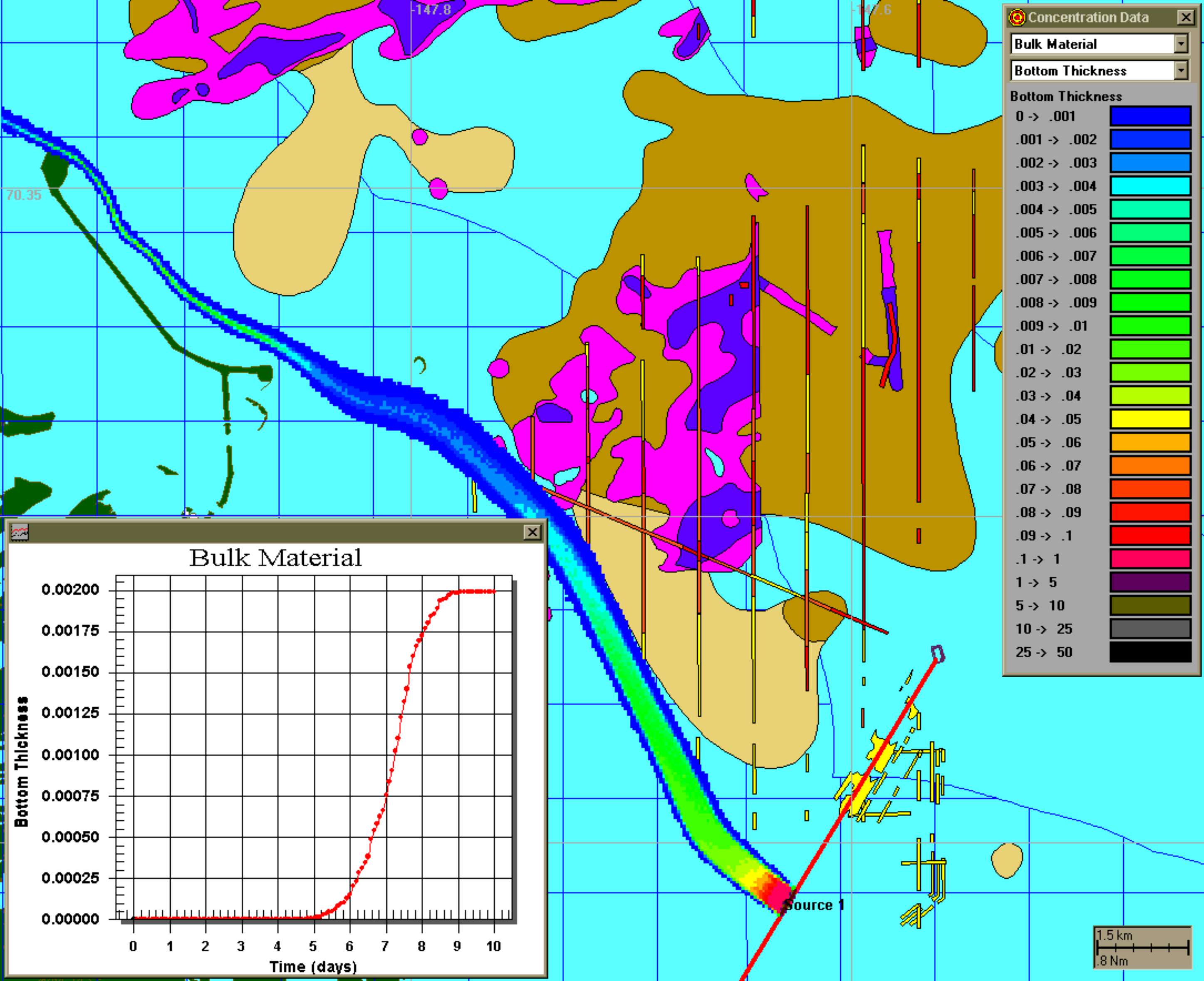

Bottom Thickness (mm)

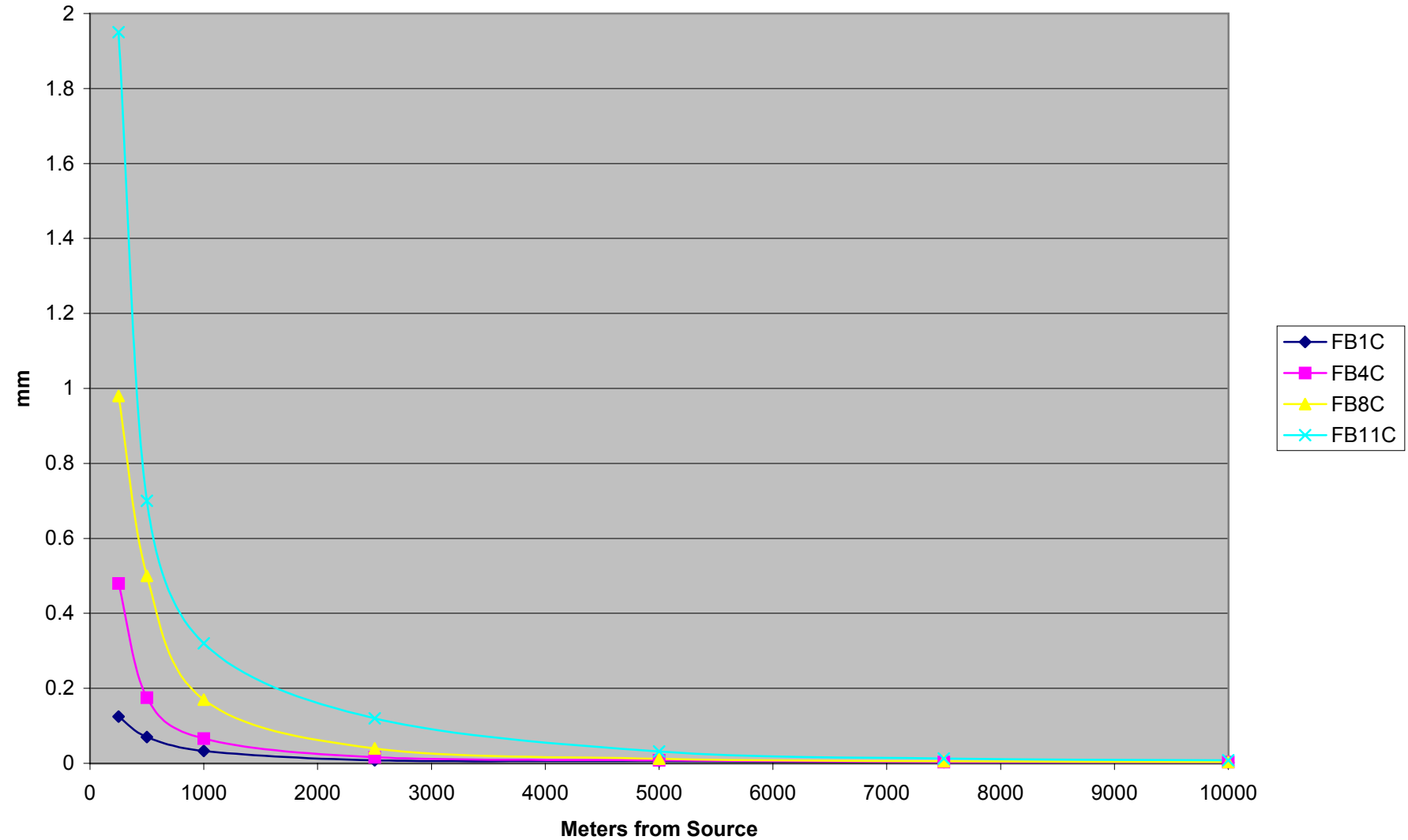

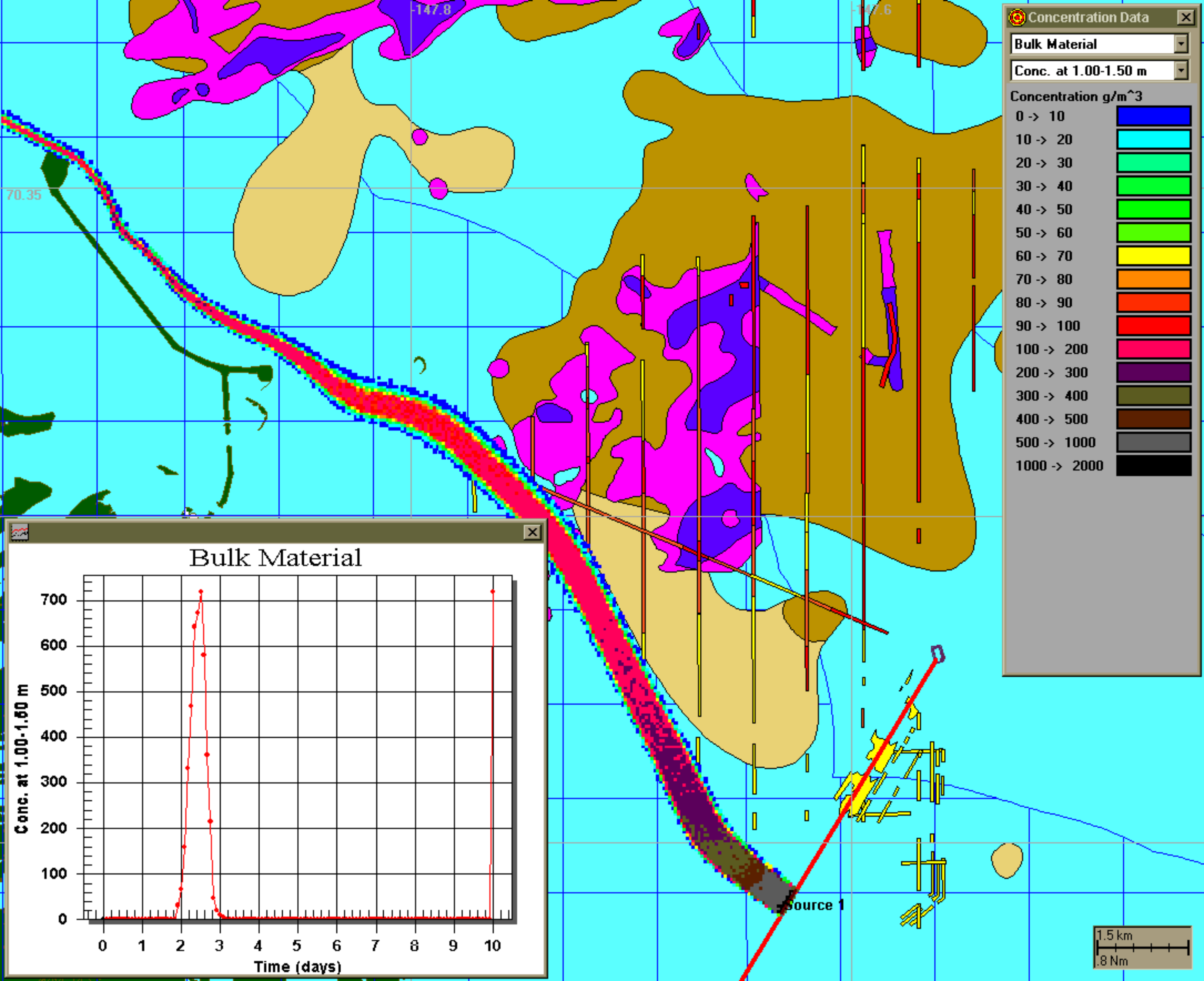

Concentration Data

Bulk Material

Conc. at 1.00-1.50 m

Concentration g/m^3

0 -> 10	Blue
10 -> 20	Cyan
20 -> 30	Light Green
30 -> 40	Green
40 -> 50	Bright Green
50 -> 60	Yellow-Green
60 -> 70	Yellow
70 -> 80	Orange
80 -> 90	Red-Orange
90 -> 100	Red
100 -> 200	Magenta
200 -> 300	Dark Purple
300 -> 400	Olive Green
400 -> 500	Brown
500 -> 1000	Grey
1000 -> 2000	Black

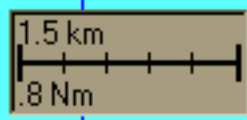
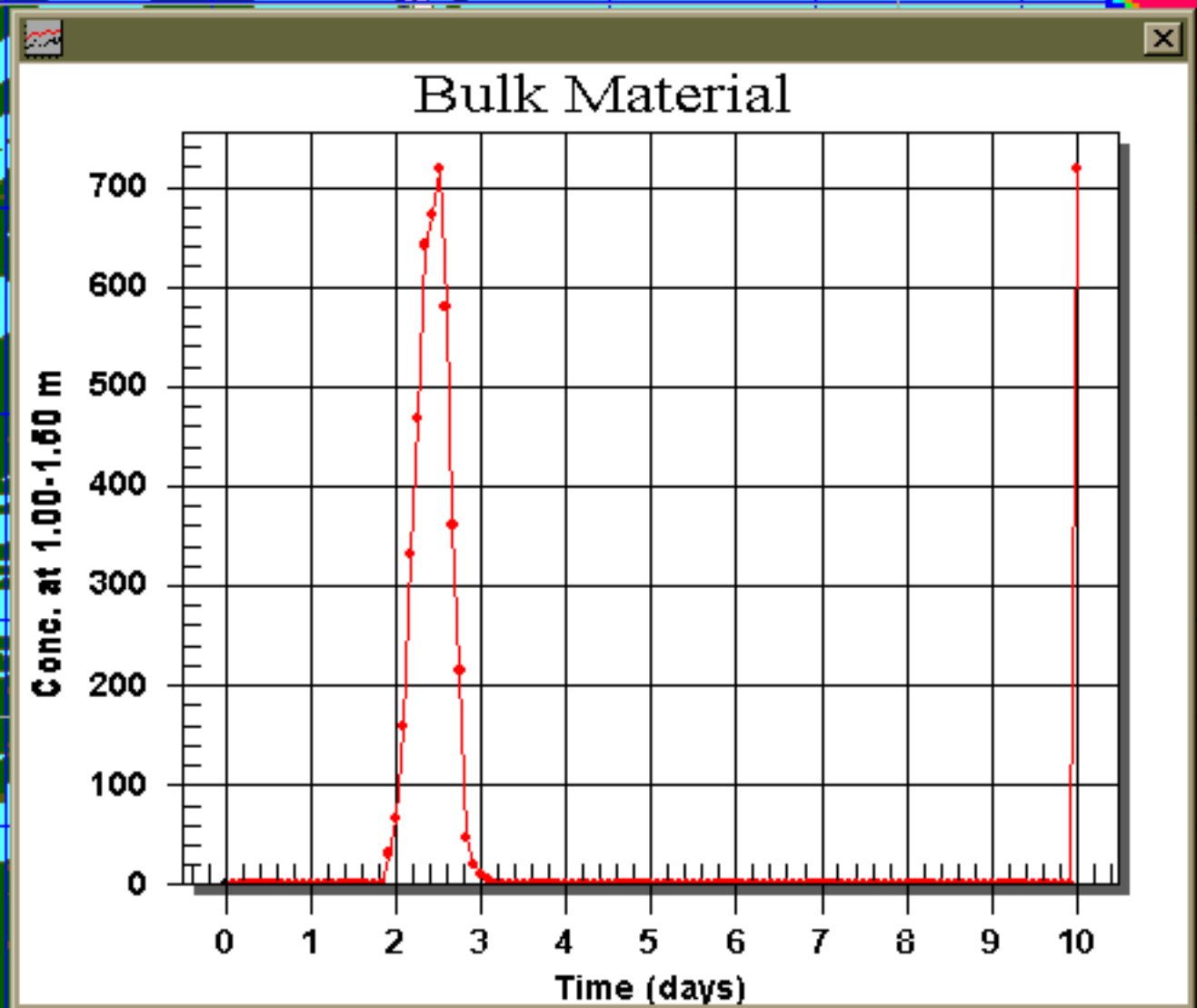

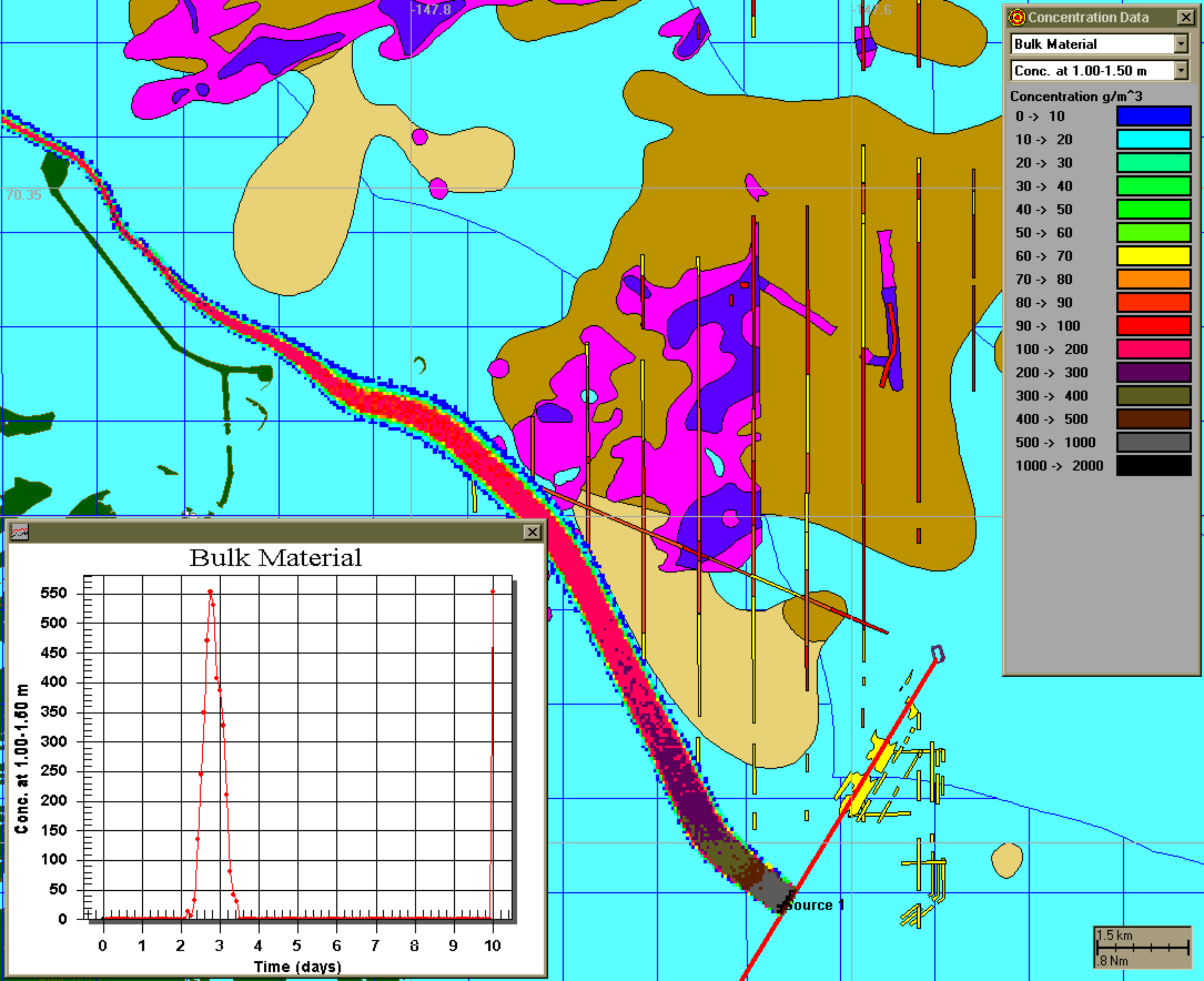

Concentration Data

Bulk Material

Conc. at 1.00-1.50 m

Concentration g/m^3

0 -> 10	Blue
10 -> 20	Cyan
20 -> 30	Light Green
30 -> 40	Green
40 -> 50	Bright Green
50 -> 60	Yellow-Green
60 -> 70	Yellow
70 -> 80	Orange
80 -> 90	Red-Orange
90 -> 100	Red
100 -> 200	Magenta
200 -> 300	Dark Purple
300 -> 400	Olive Green
400 -> 500	Brown
500 -> 1000	Grey
1000 -> 2000	Black

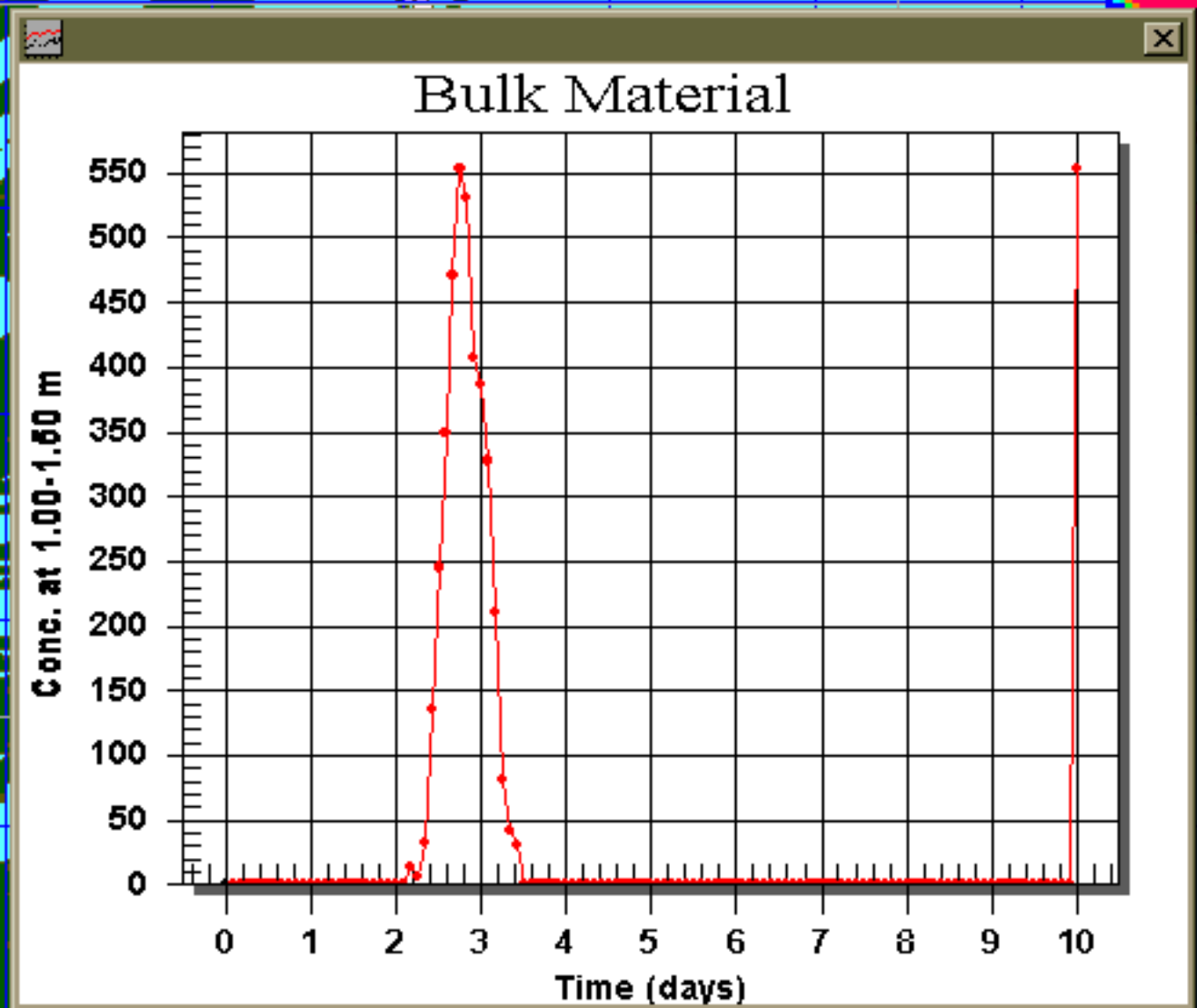

1.5 km
0.8 Nm

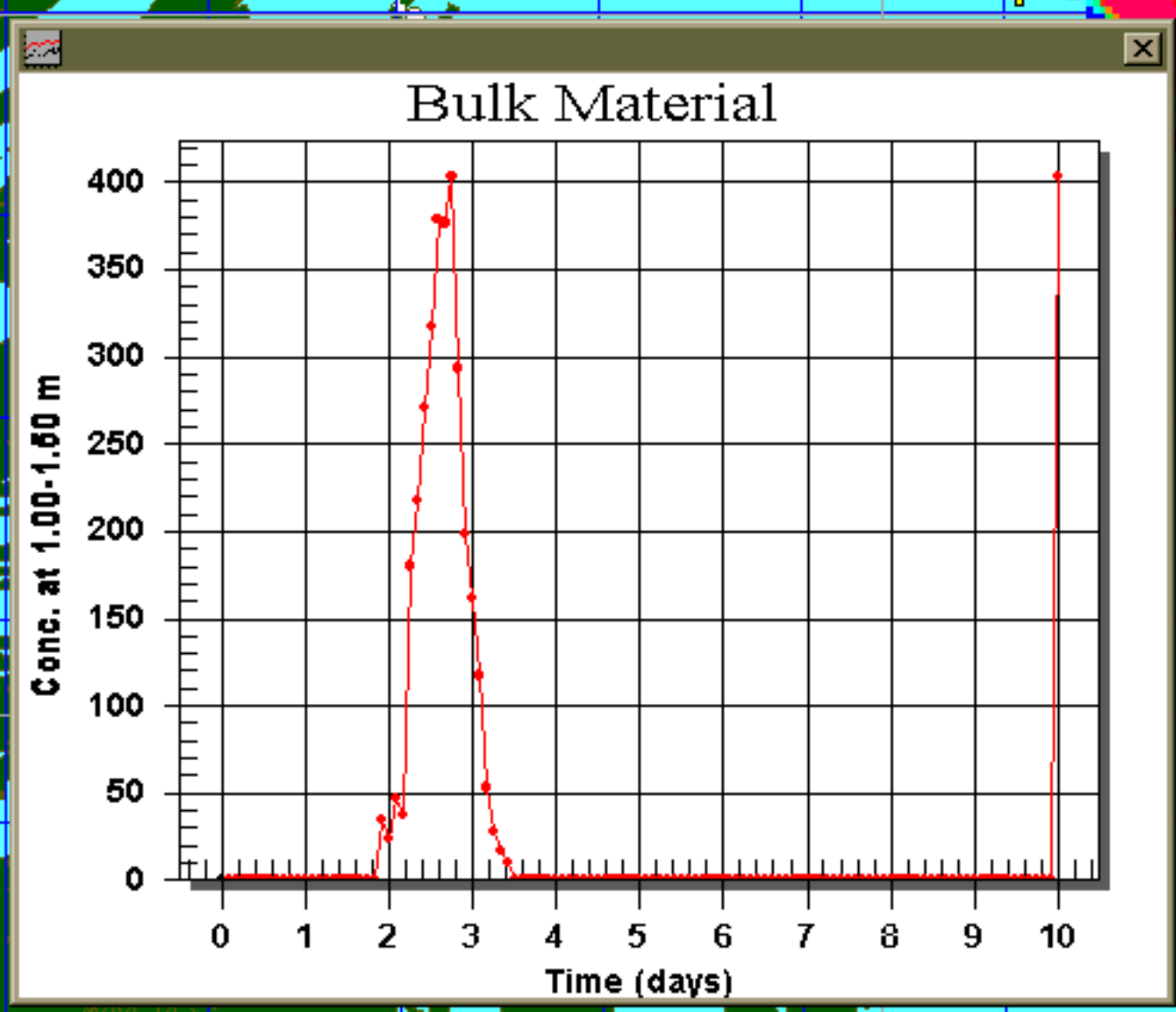
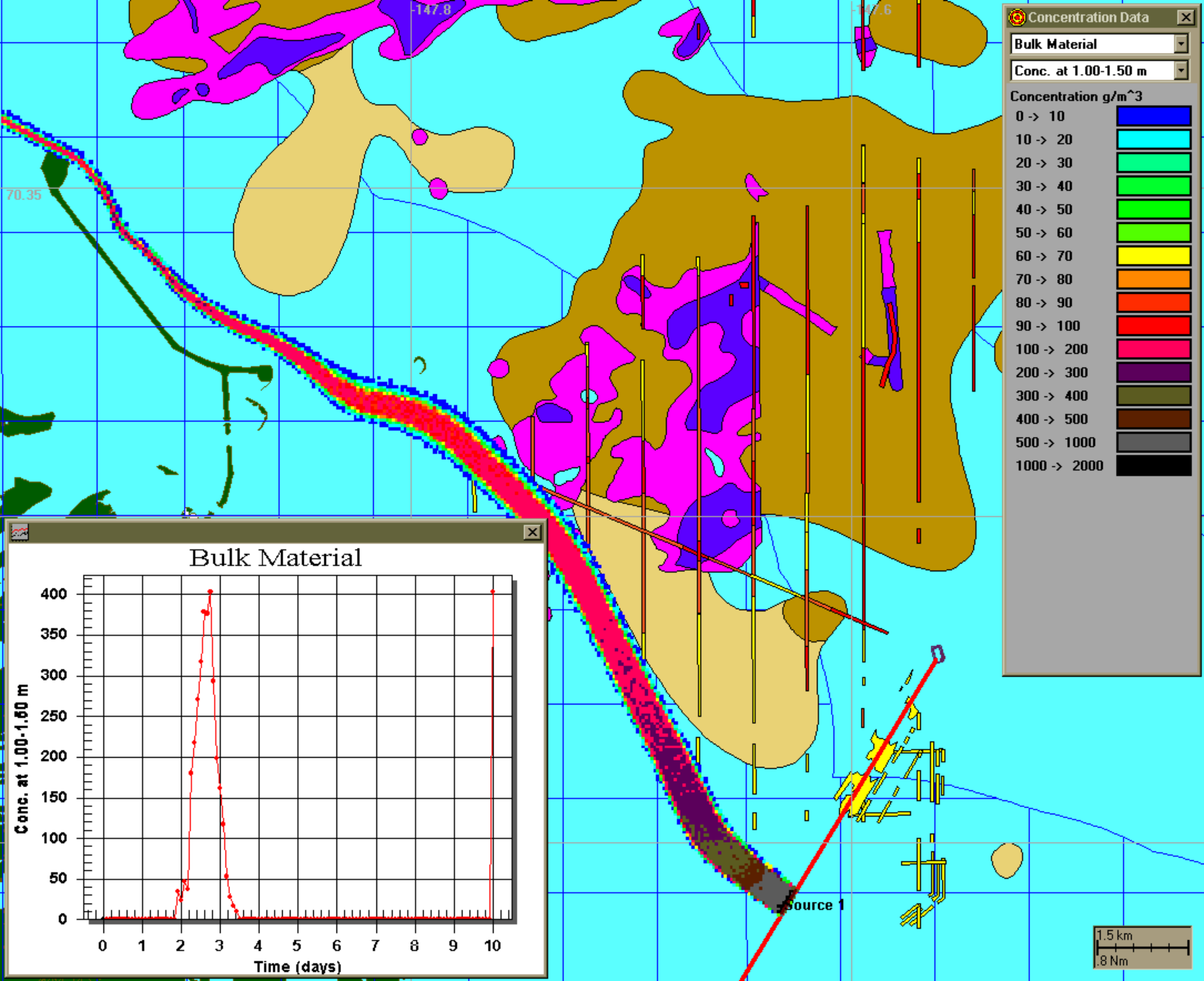

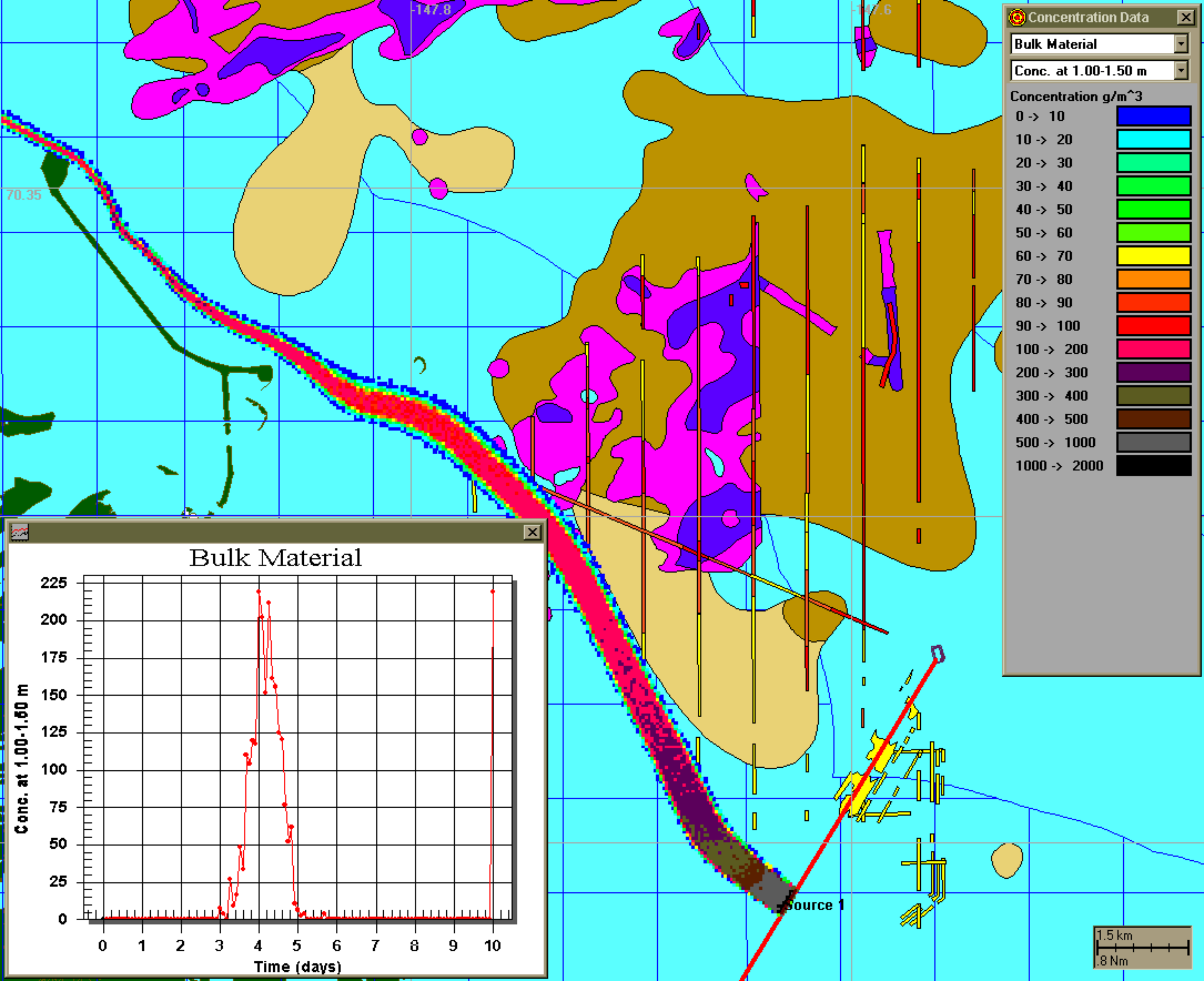

Concentration Data

Bulk Material

Conc. at 1.00-1.50 m

Concentration g/m^3

0 -> 10	Blue
10 -> 20	Cyan
20 -> 30	Light Green
30 -> 40	Green
40 -> 50	Bright Green
50 -> 60	Yellow-Green
60 -> 70	Yellow
70 -> 80	Orange
80 -> 90	Red-Orange
90 -> 100	Red
100 -> 200	Magenta
200 -> 300	Purple
300 -> 400	Olive
400 -> 500	Brown
500 -> 1000	Grey
1000 -> 2000	Black

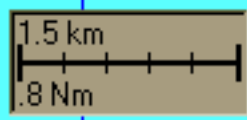
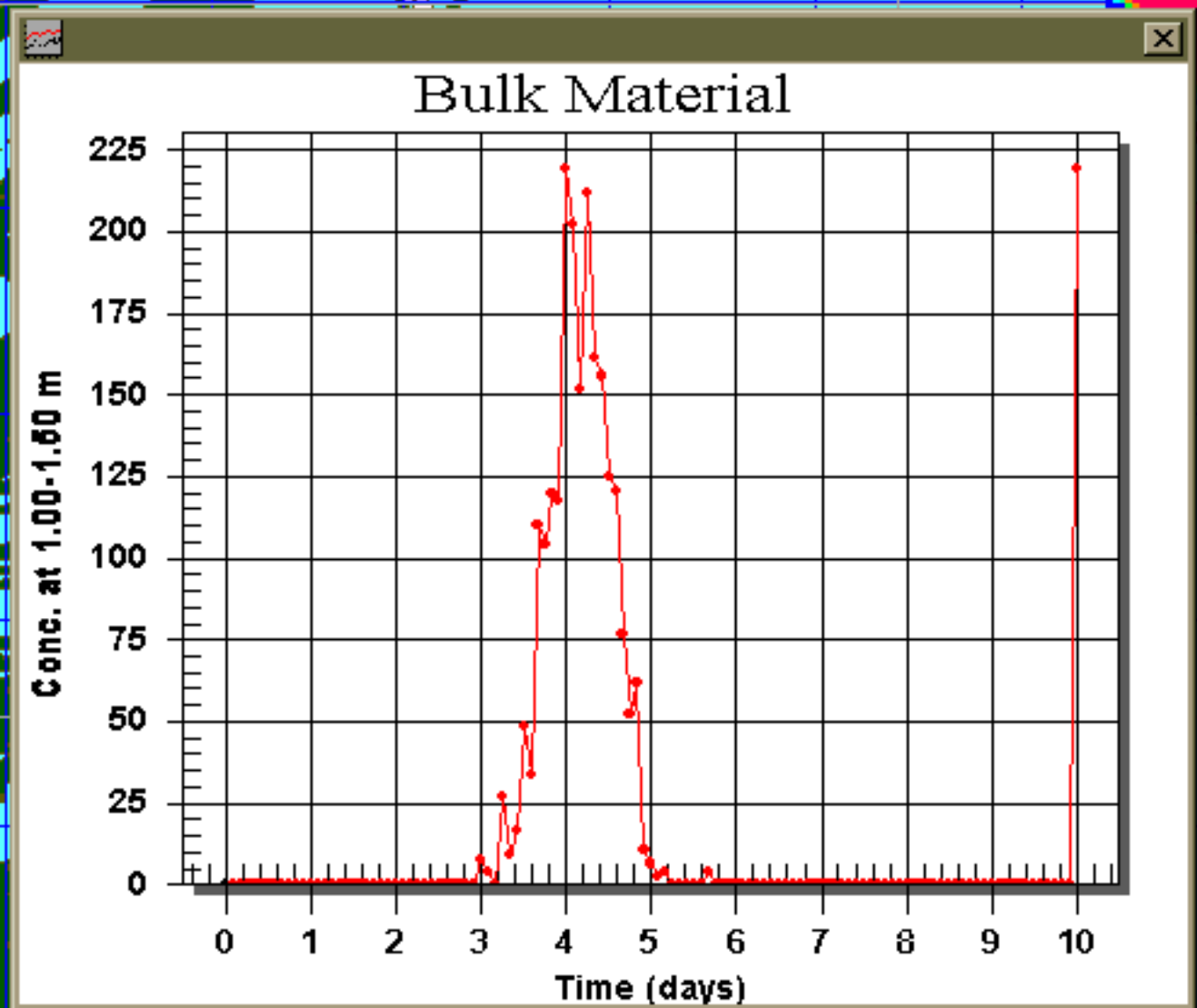

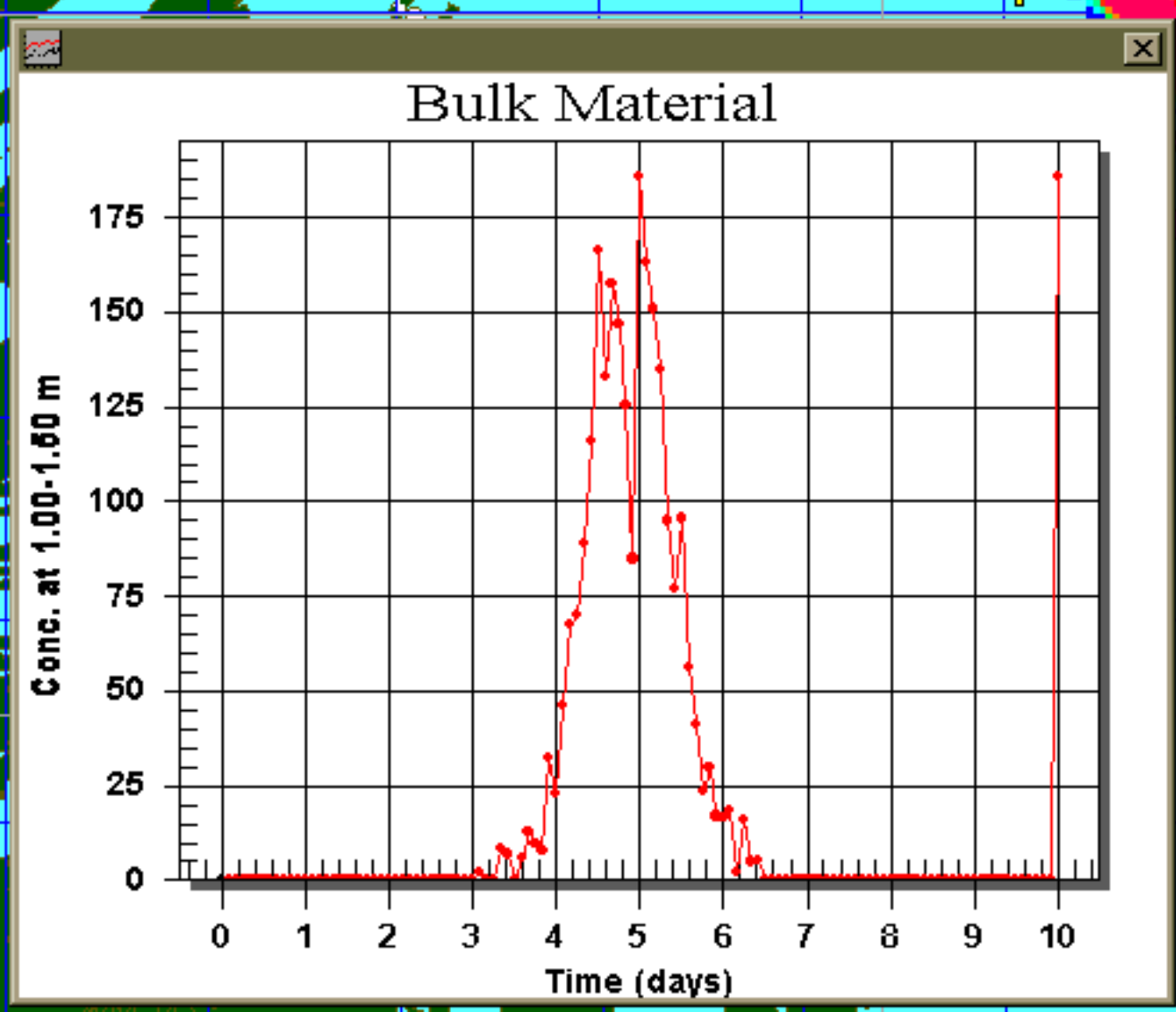
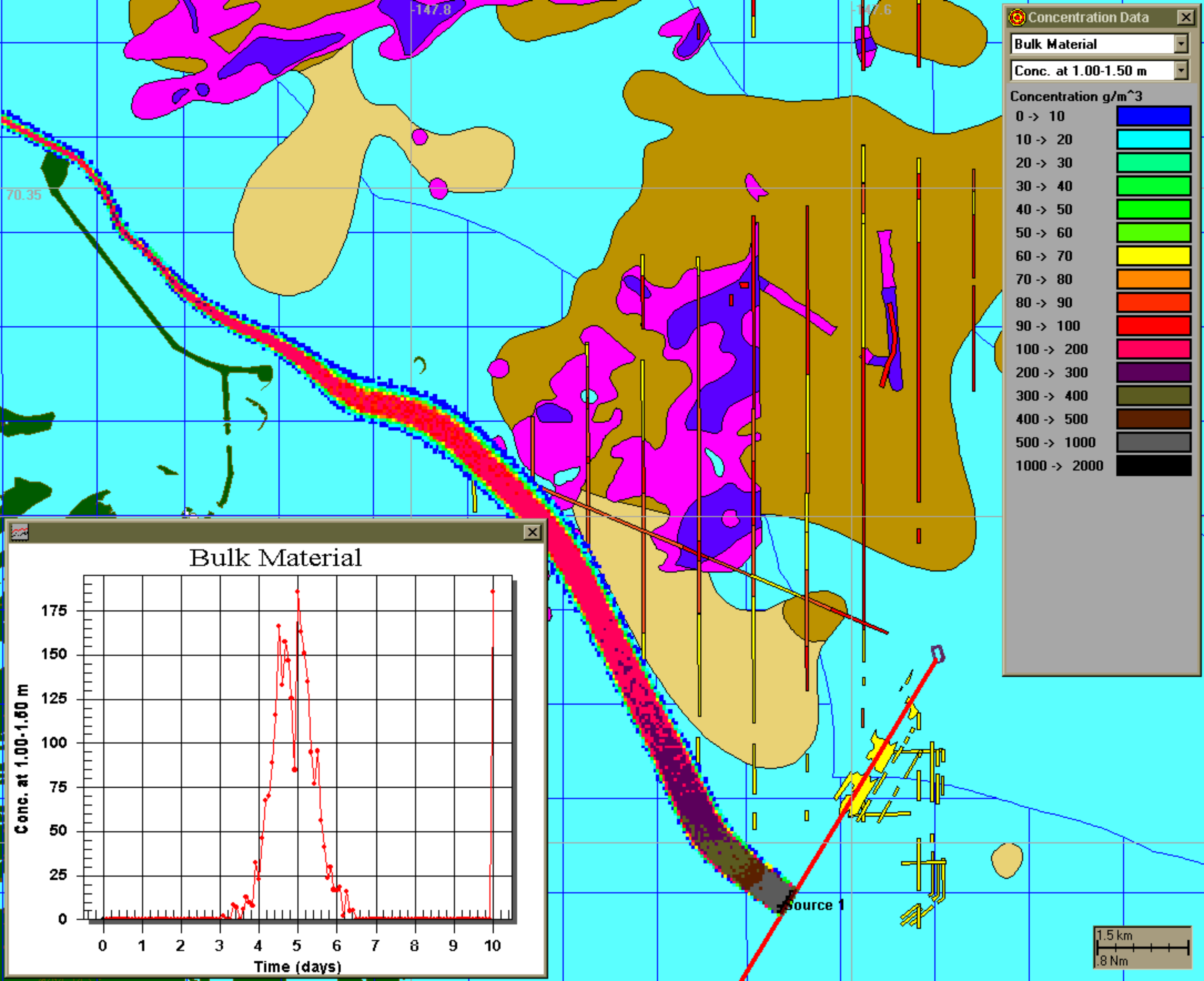

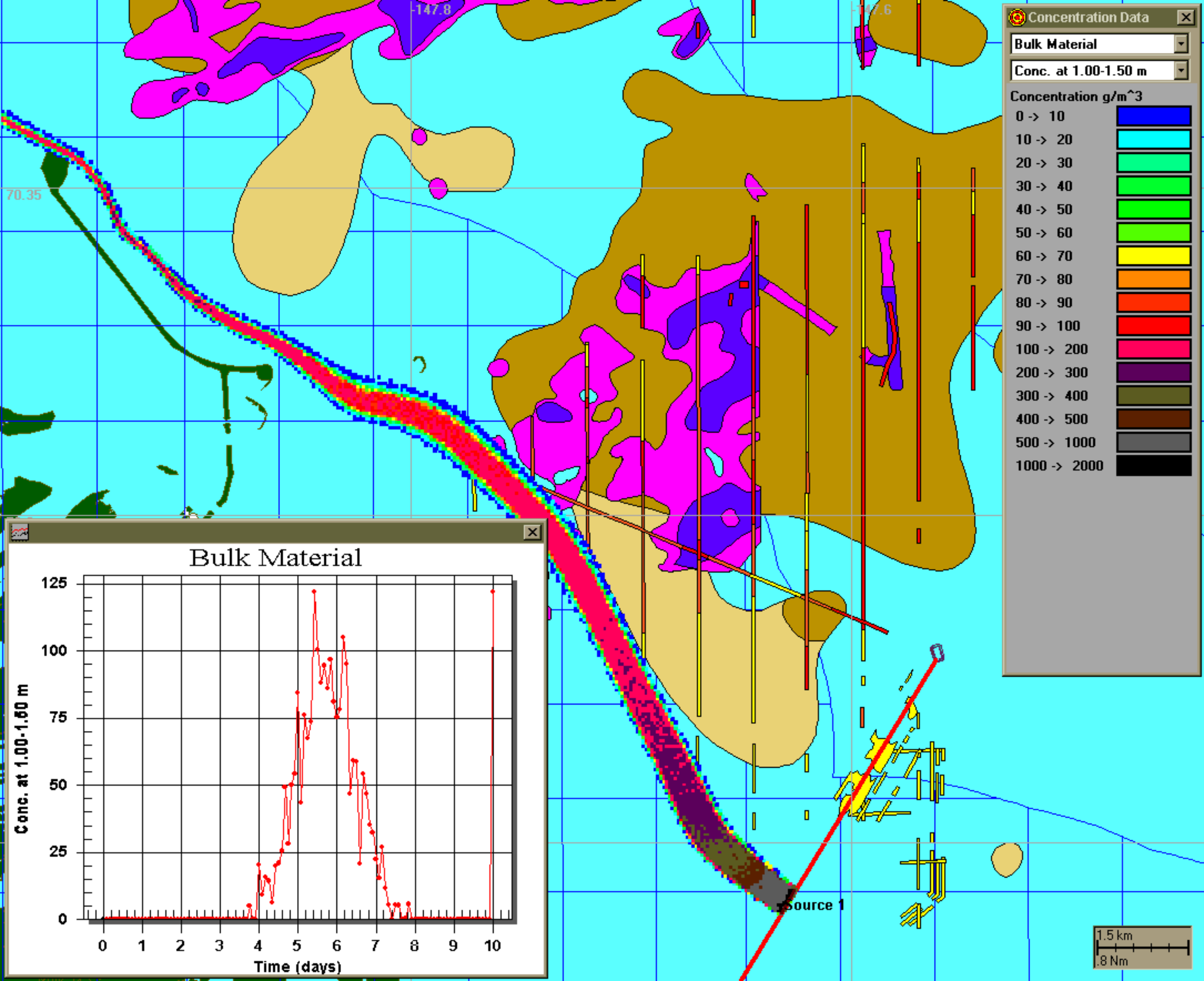

Concentration Data

Bulk Material

Conc. at 1.00-1.50 m

Concentration g/m^3

0 -> 10	Blue
10 -> 20	Cyan
20 -> 30	Light Green
30 -> 40	Green
40 -> 50	Bright Green
50 -> 60	Yellow-Green
60 -> 70	Yellow
70 -> 80	Orange
80 -> 90	Red-Orange
90 -> 100	Red
100 -> 200	Magenta
200 -> 300	Purple
300 -> 400	Olive
400 -> 500	Brown
500 -> 1000	Grey
1000 -> 2000	Black

Bulk Material

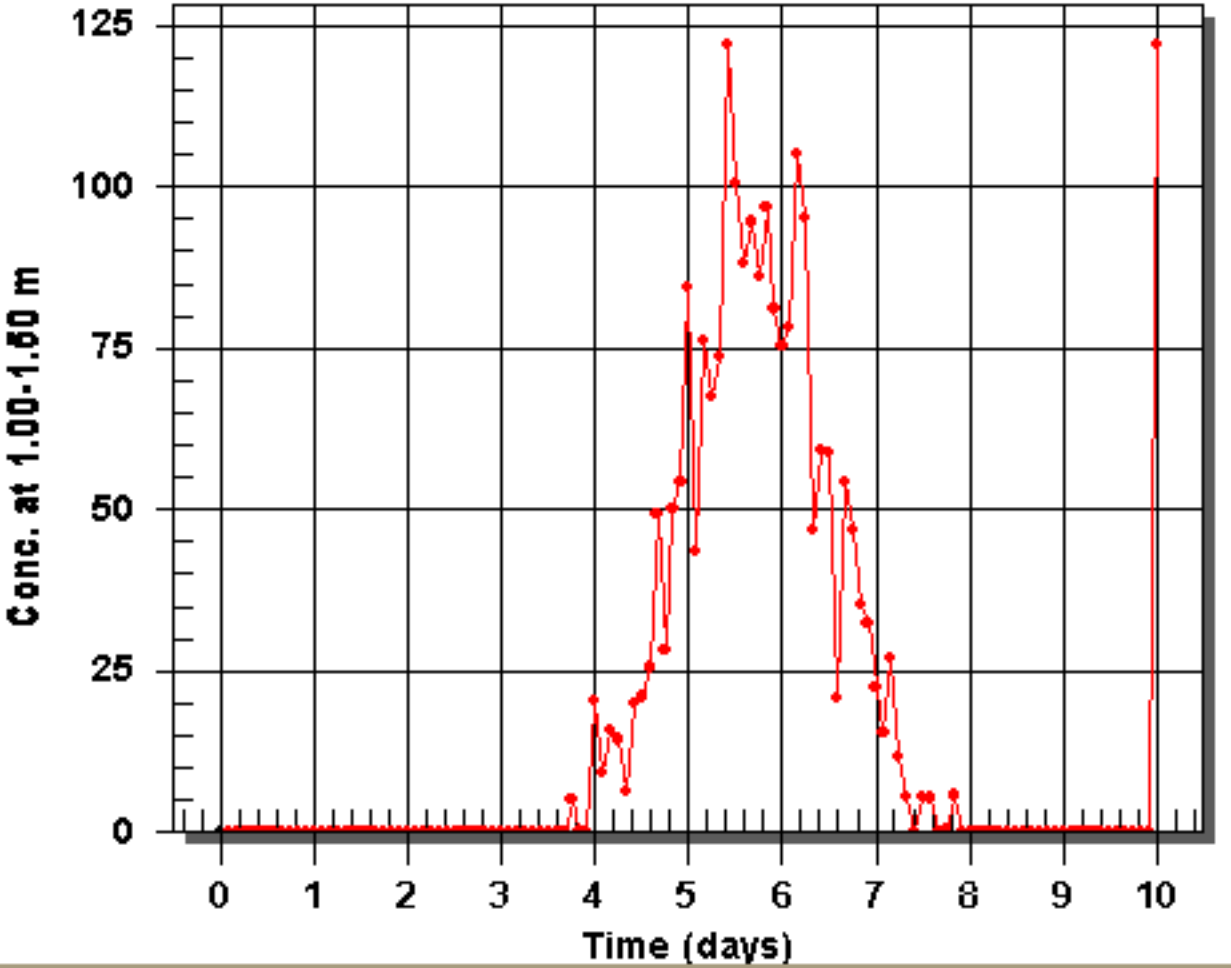

Source 1

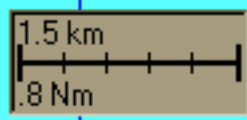

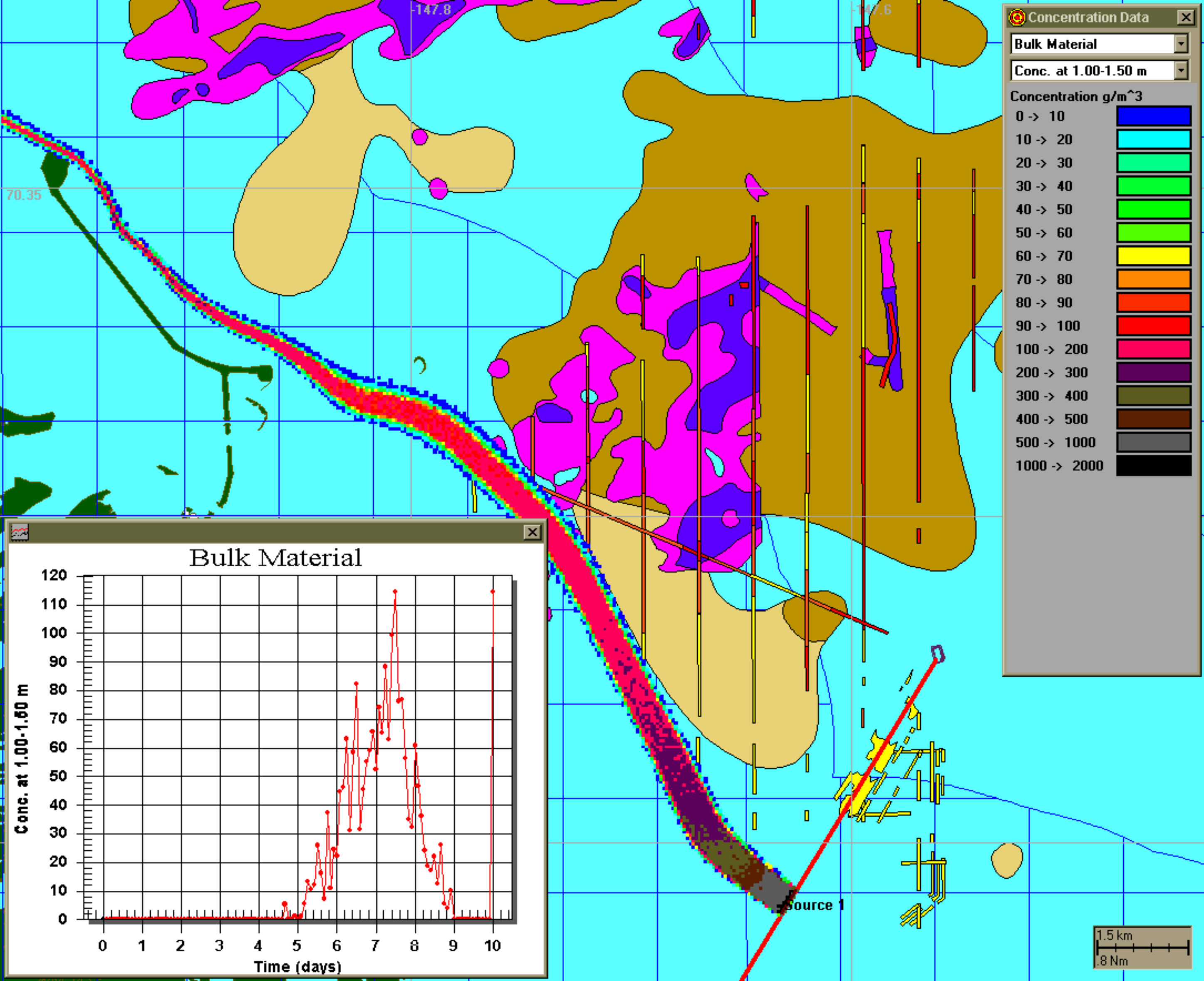

Concentration Data

Bulk Material

Conc. at 1.00-1.50 m

Concentration g/m³

0 -> 10	Blue
10 -> 20	Cyan
20 -> 30	Light Green
30 -> 40	Green
40 -> 50	Bright Green
50 -> 60	Yellow-Green
60 -> 70	Yellow
70 -> 80	Orange
80 -> 90	Red-Orange
90 -> 100	Red
100 -> 200	Magenta
200 -> 300	Purple
300 -> 400	Olive
400 -> 500	Brown
500 -> 1000	Grey
1000 -> 2000	Black

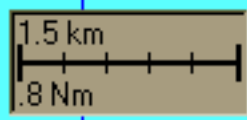
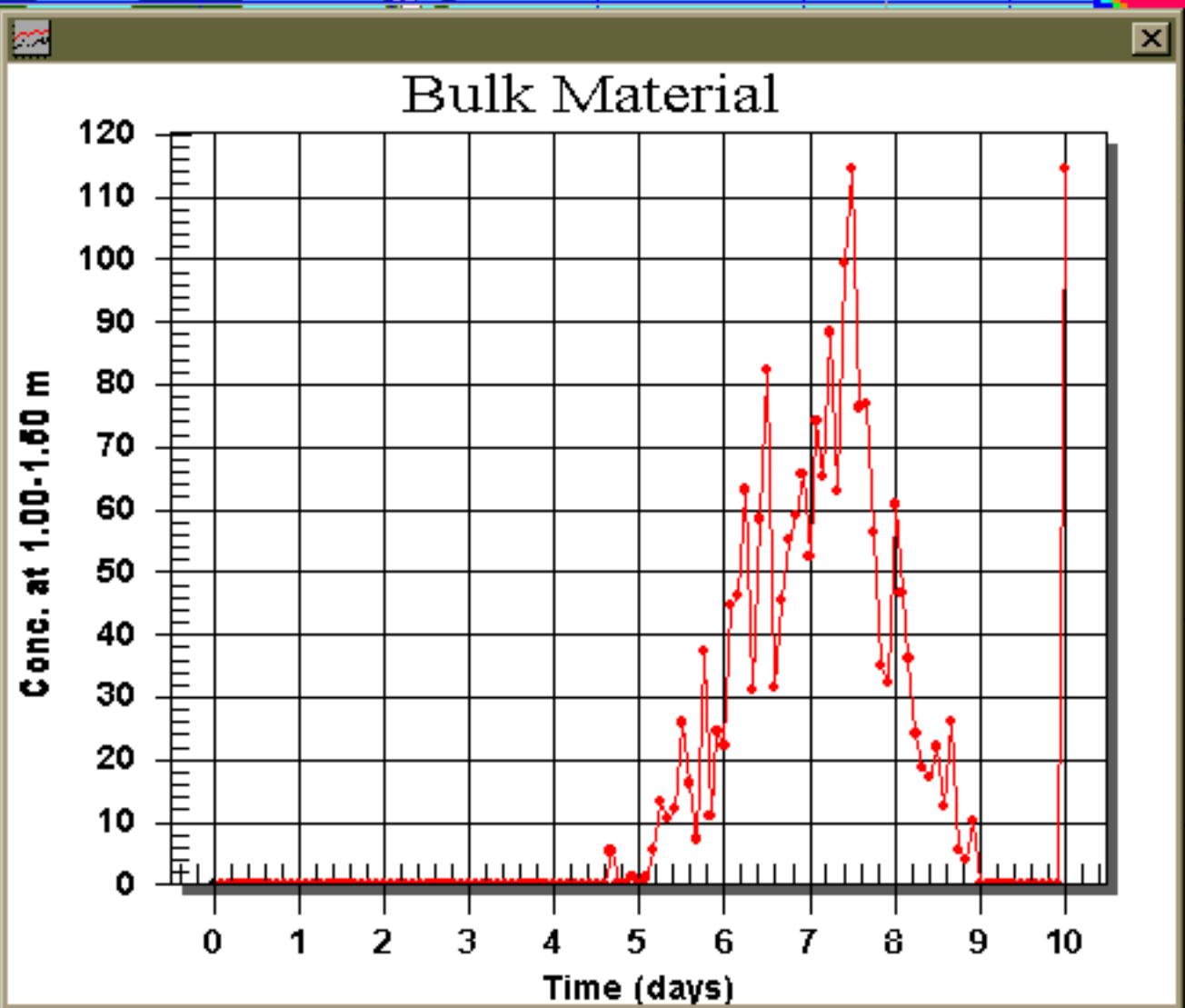

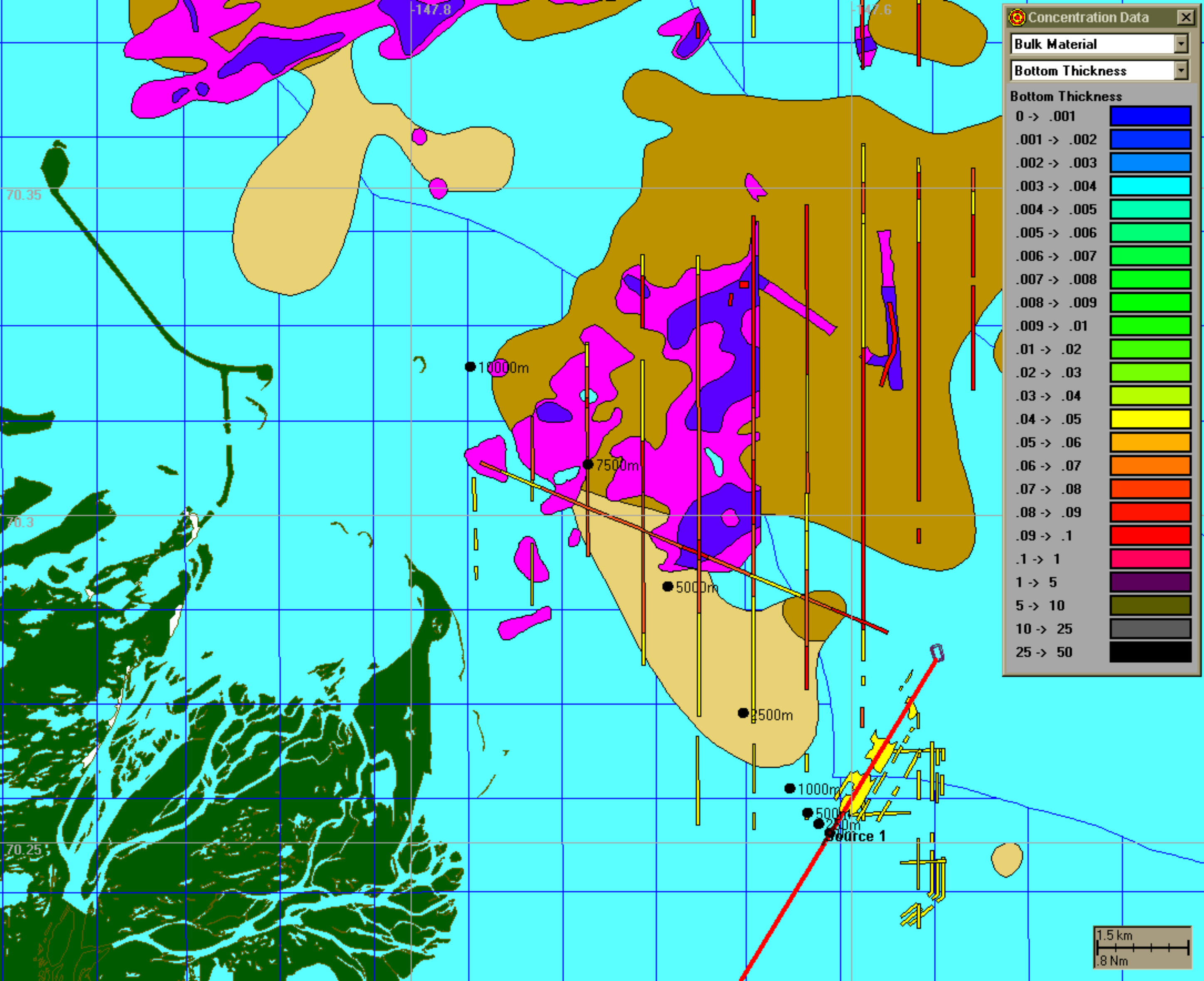

Concentration Data

Bulk Material

Bottom Thickness

Bottom Thickness

0 -> .001	[Dark Blue]
.001 -> .002	[Blue]
.002 -> .003	[Light Blue]
.003 -> .004	[Cyan]
.004 -> .005	[Green-Cyan]
.005 -> .006	[Green]
.006 -> .007	[Light Green]
.007 -> .008	[Yellow-Green]
.008 -> .009	[Yellow]
.009 -> .01	[Light Yellow]
.01 -> .02	[Yellow-Orange]
.02 -> .03	[Orange]
.03 -> .04	[Light Orange]
.04 -> .05	[Orange-Red]
.05 -> .06	[Red-Orange]
.06 -> .07	[Red]
.07 -> .08	[Dark Red]
.08 -> .09	[Red-Black]
.09 -> .1	[Black-Red]
.1 -> 1	[Black]
1 -> 5	[Dark Purple]
5 -> 10	[Purple]
10 -> 25	[Dark Grey]
25 -> 50	[Black]

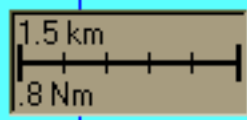

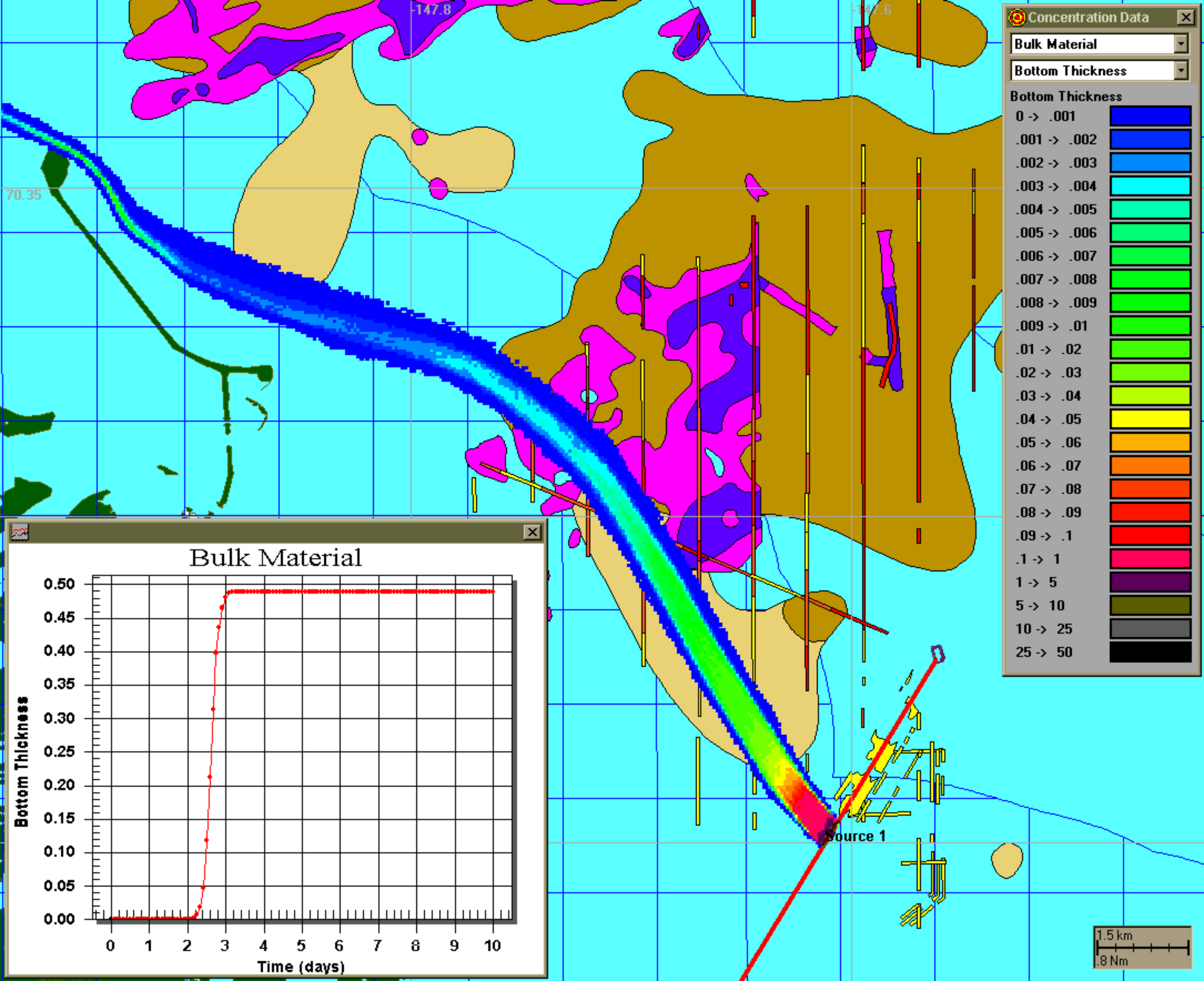

Concentration Data

Bulk Material

Bottom Thickness

Bottom Thickness

0 -> .001	[Dark Blue]
.001 -> .002	[Blue]
.002 -> .003	[Light Blue]
.003 -> .004	[Cyan]
.004 -> .005	[Green-Cyan]
.005 -> .006	[Green]
.006 -> .007	[Light Green]
.007 -> .008	[Green]
.008 -> .009	[Light Green]
.009 -> .01	[Green]
.01 -> .02	[Light Green]
.02 -> .03	[Yellow-Green]
.03 -> .04	[Yellow]
.04 -> .05	[Orange-Yellow]
.05 -> .06	[Orange]
.06 -> .07	[Red-Orange]
.07 -> .08	[Red]
.08 -> .09	[Dark Red]
.09 -> .1	[Red]
.1 -> 1	[Magenta]
1 -> 5	[Purple]
5 -> 10	[Dark Purple]
10 -> 25	[Black-Gray]
25 -> 50	[Black]

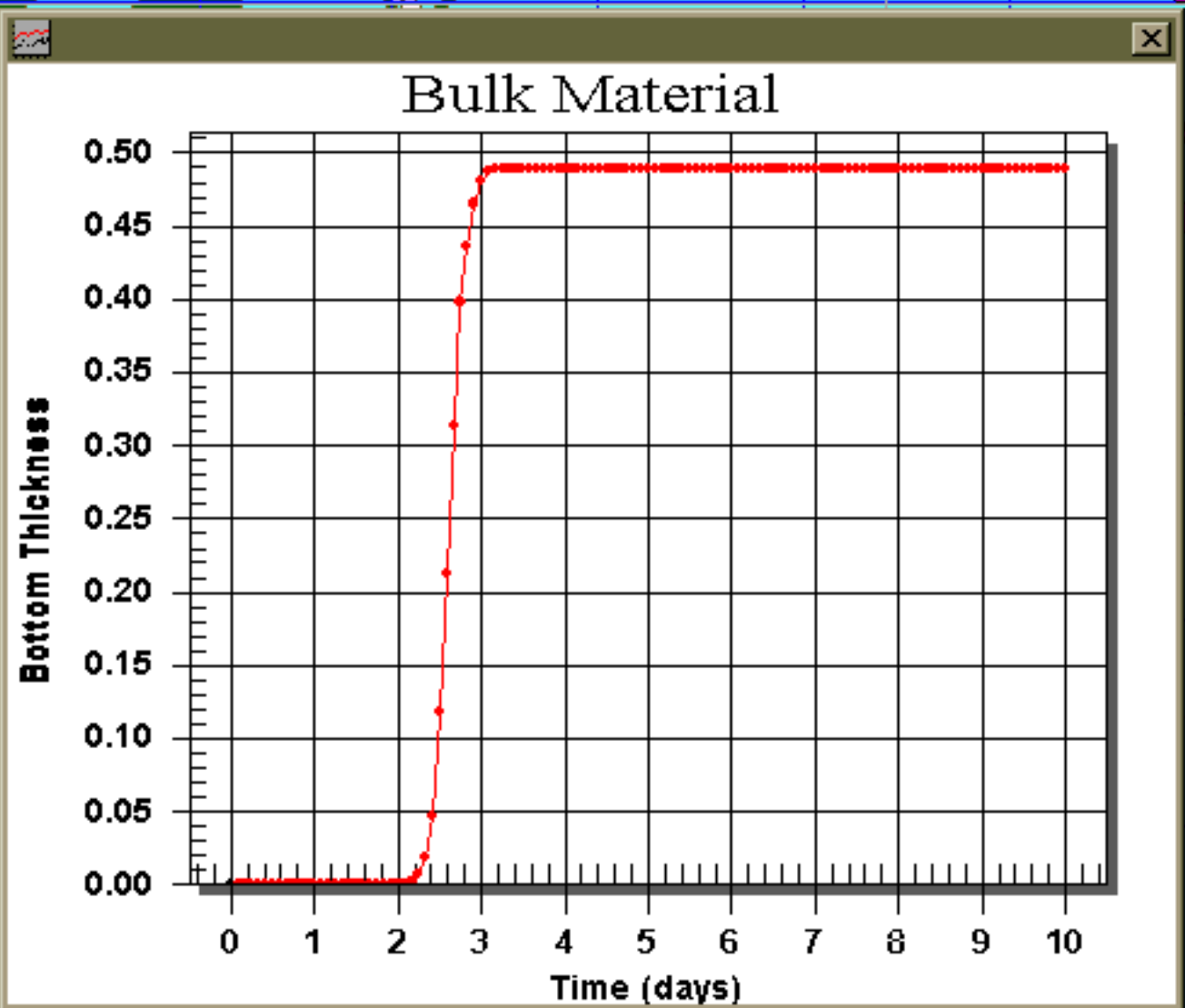

1.5 km
0.8 Nm

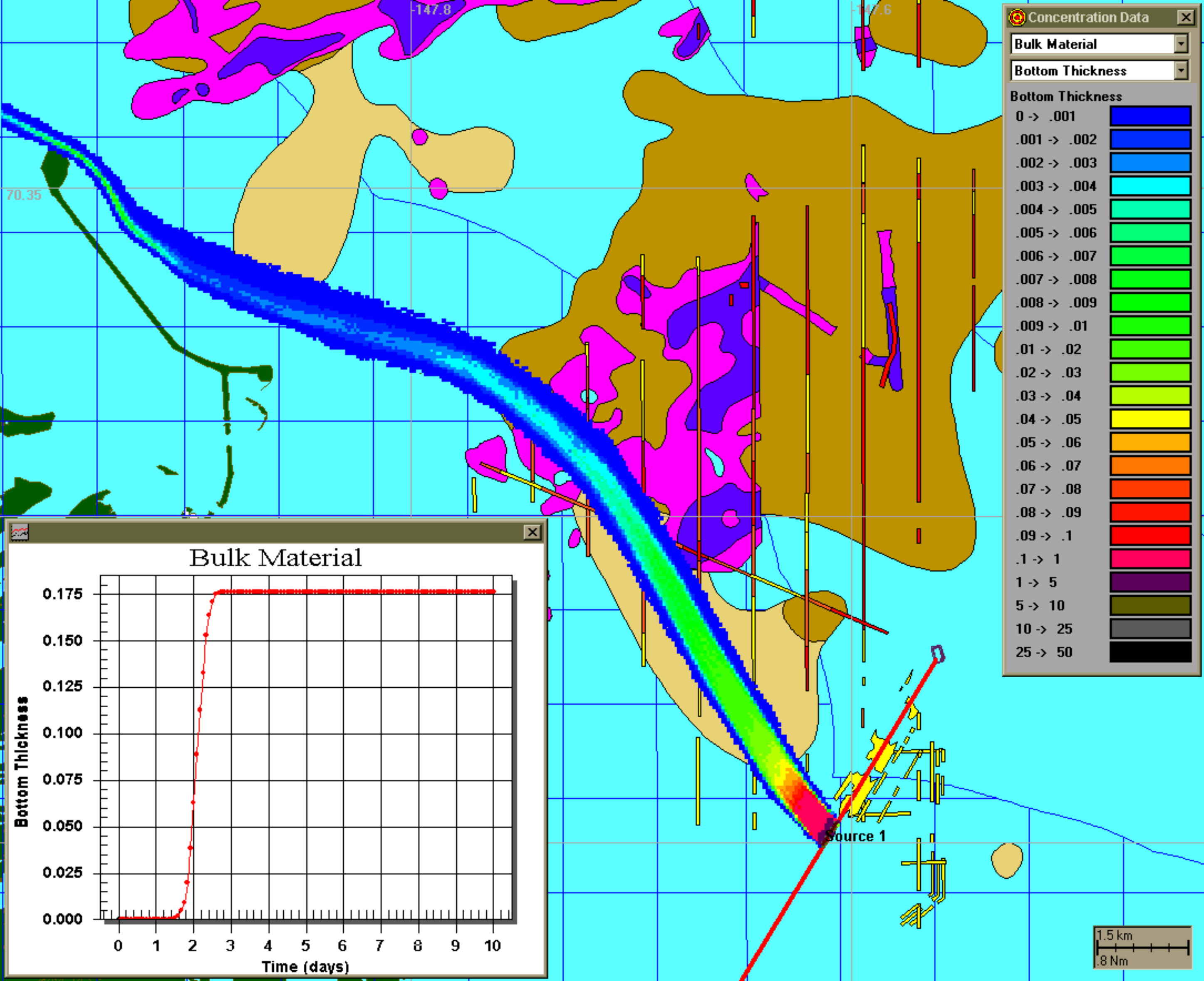

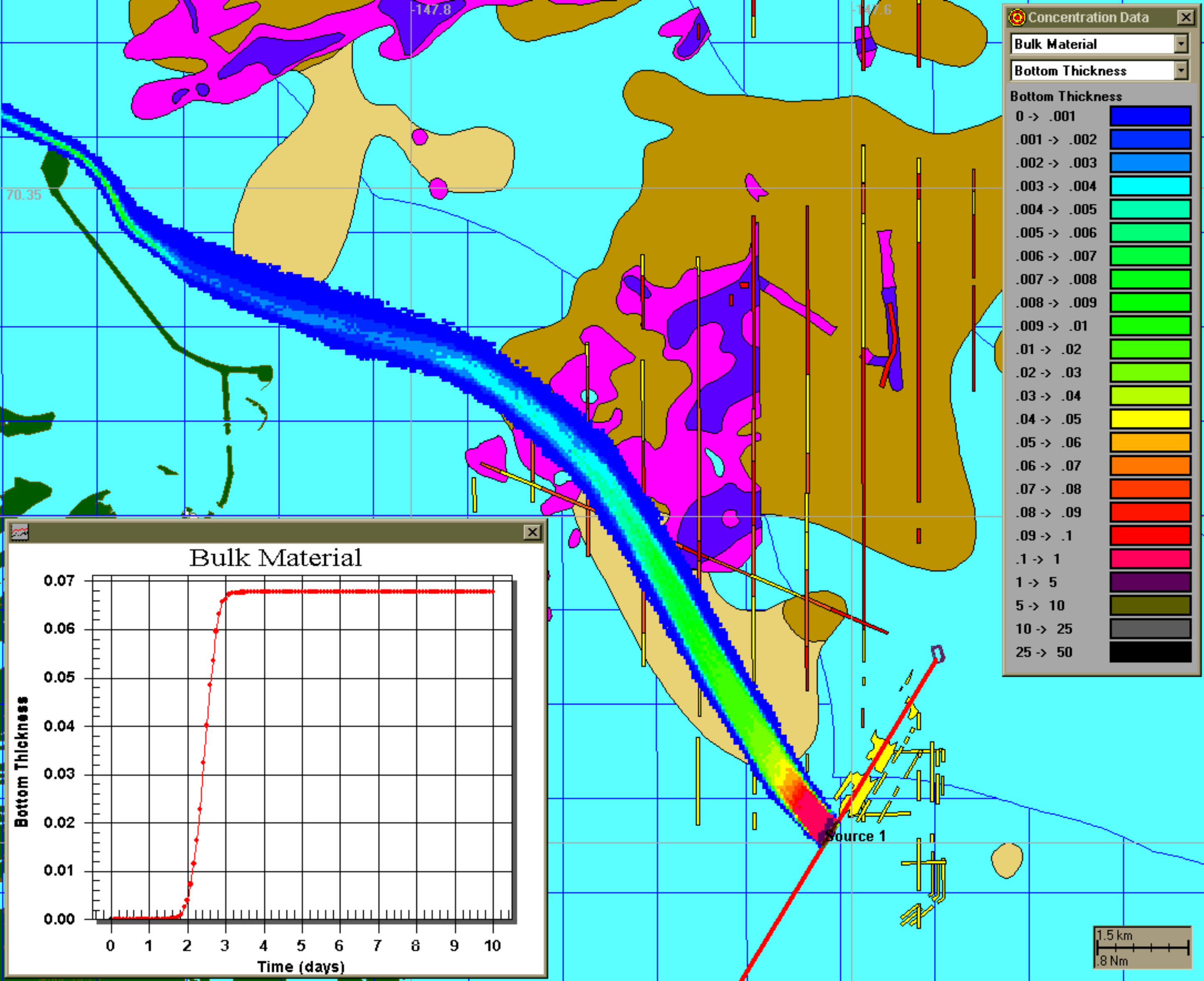

Concentration Data

Bulk Material

Bottom Thickness

Bottom Thickness

0 -> .001	[Dark Blue]
.001 -> .002	[Blue]
.002 -> .003	[Light Blue]
.003 -> .004	[Cyan]
.004 -> .005	[Green-Cyan]
.005 -> .006	[Green]
.006 -> .007	[Light Green]
.007 -> .008	[Green]
.008 -> .009	[Light Green]
.009 -> .01	[Green]
.01 -> .02	[Light Green]
.02 -> .03	[Yellow-Green]
.03 -> .04	[Yellow]
.04 -> .05	[Orange-Yellow]
.05 -> .06	[Orange]
.06 -> .07	[Red-Orange]
.07 -> .08	[Red]
.08 -> .09	[Dark Red]
.09 -> .1	[Red]
.1 -> 1	[Magenta]
1 -> 5	[Purple]
5 -> 10	[Dark Purple]
10 -> 25	[Black]
25 -> 50	[Black]

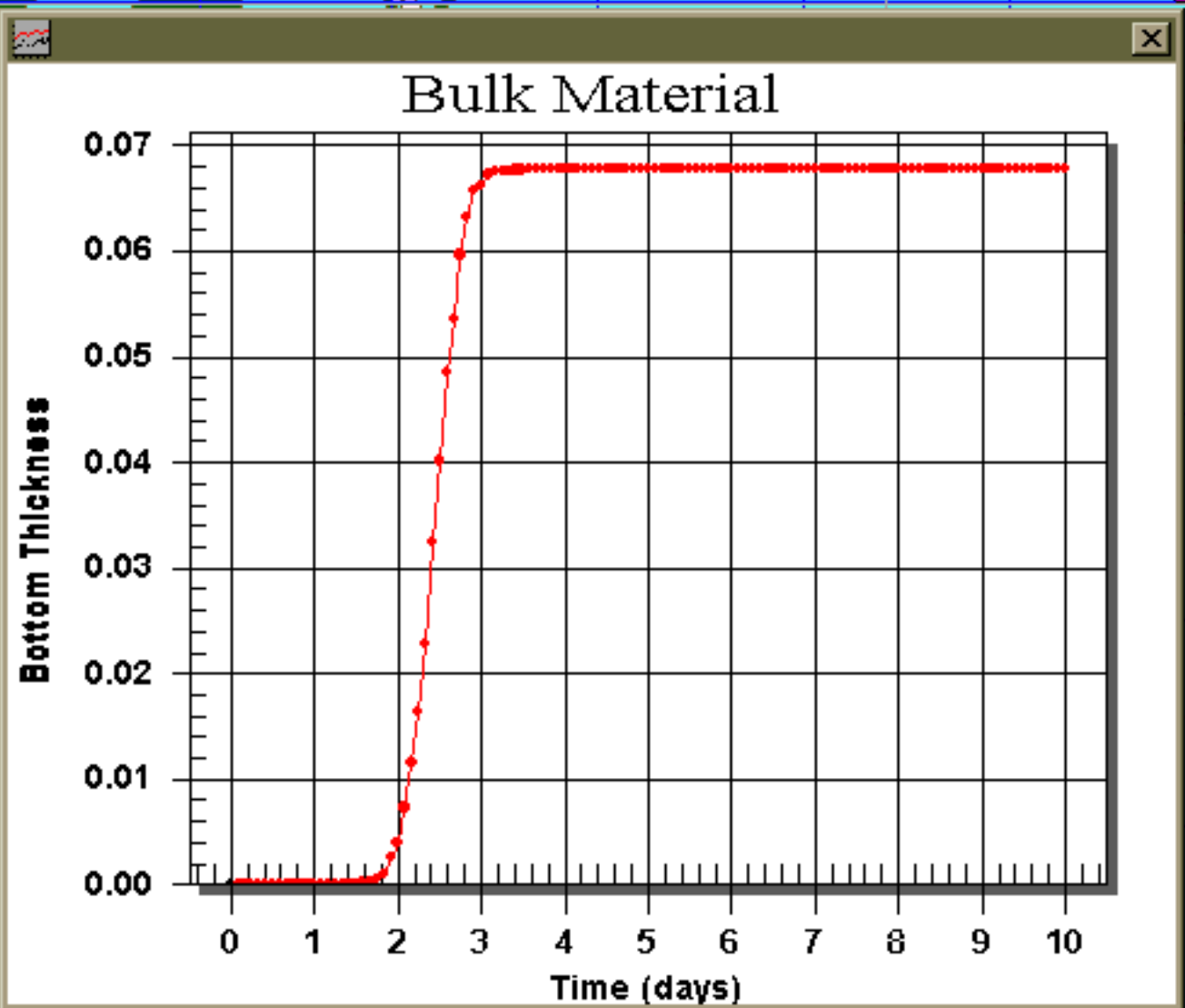

1.5 km
.8 Nm

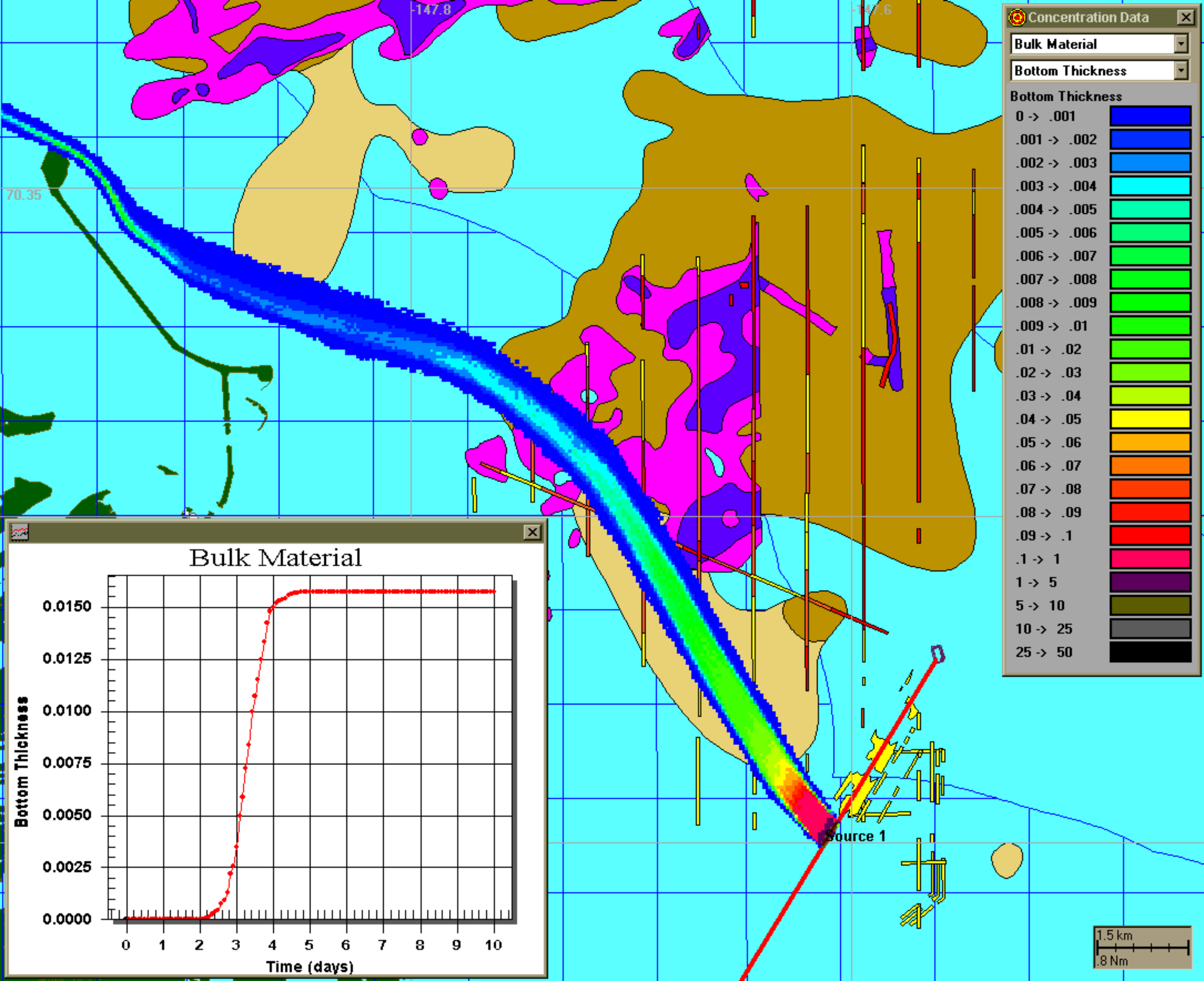

Concentration Data

Bulk Material

Bottom Thickness

Bottom Thickness

0 -> .001	[Dark Blue]
.001 -> .002	[Blue]
.002 -> .003	[Light Blue]
.003 -> .004	[Cyan]
.004 -> .005	[Green-Cyan]
.005 -> .006	[Green]
.006 -> .007	[Light Green]
.007 -> .008	[Green]
.008 -> .009	[Light Green]
.009 -> .01	[Green]
.01 -> .02	[Light Green]
.02 -> .03	[Yellow-Green]
.03 -> .04	[Yellow]
.04 -> .05	[Orange-Yellow]
.05 -> .06	[Orange]
.06 -> .07	[Red-Orange]
.07 -> .08	[Red]
.08 -> .09	[Dark Red]
.09 -> .1	[Red]
.1 -> 1	[Pink]
1 -> 5	[Purple]
5 -> 10	[Dark Purple]
10 -> 25	[Grey]
25 -> 50	[Black]

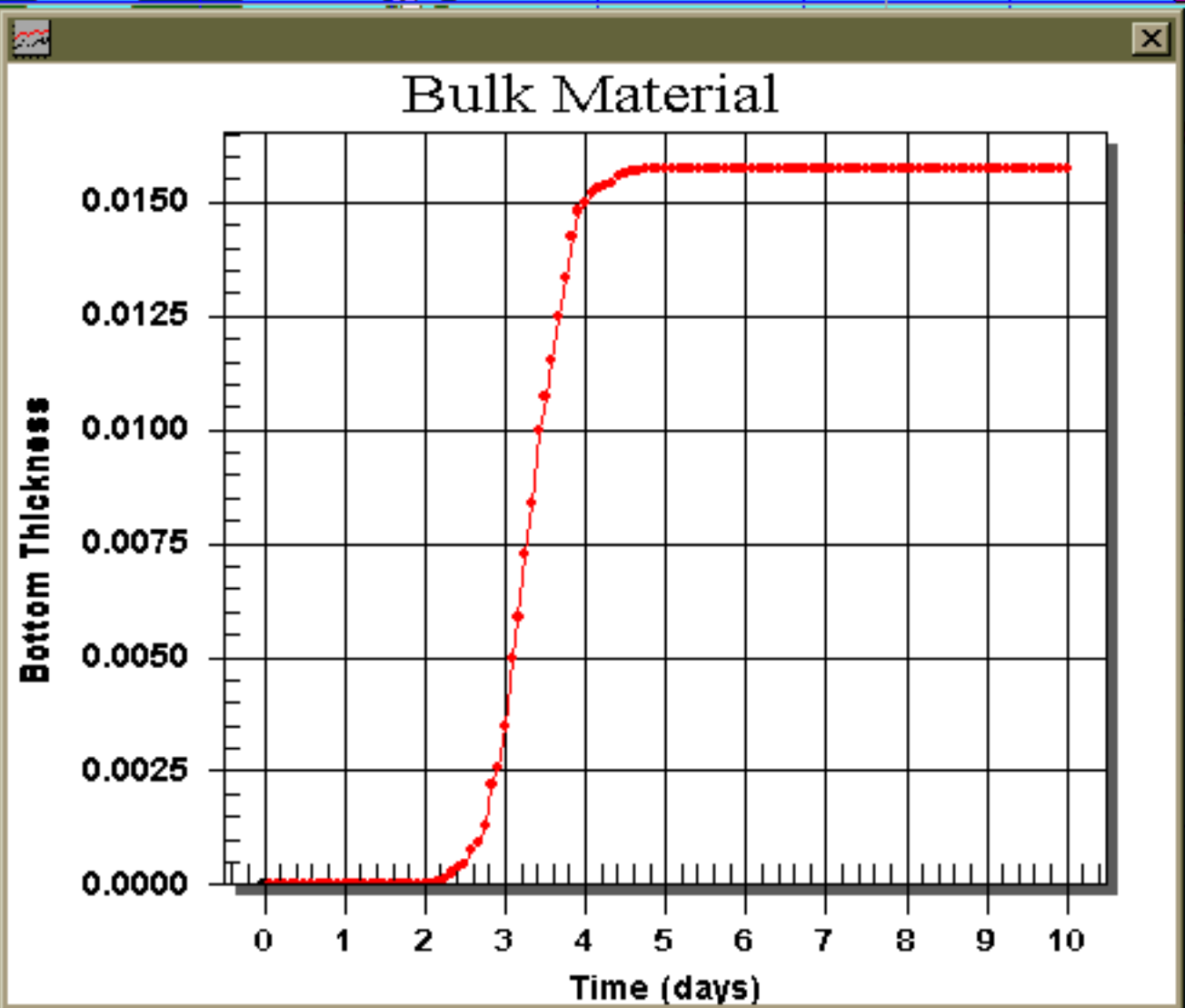

1.5 km
0.8 Nm

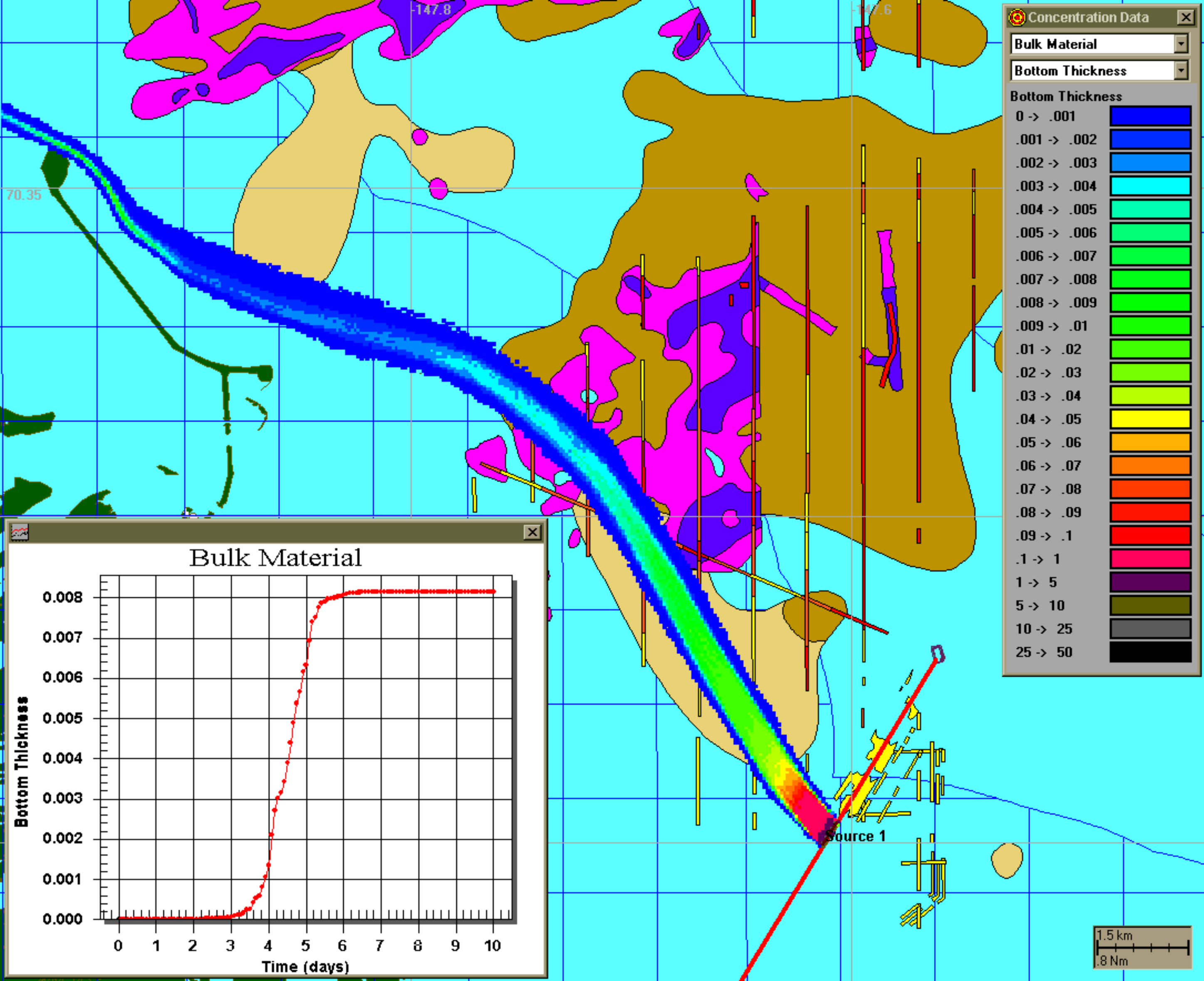

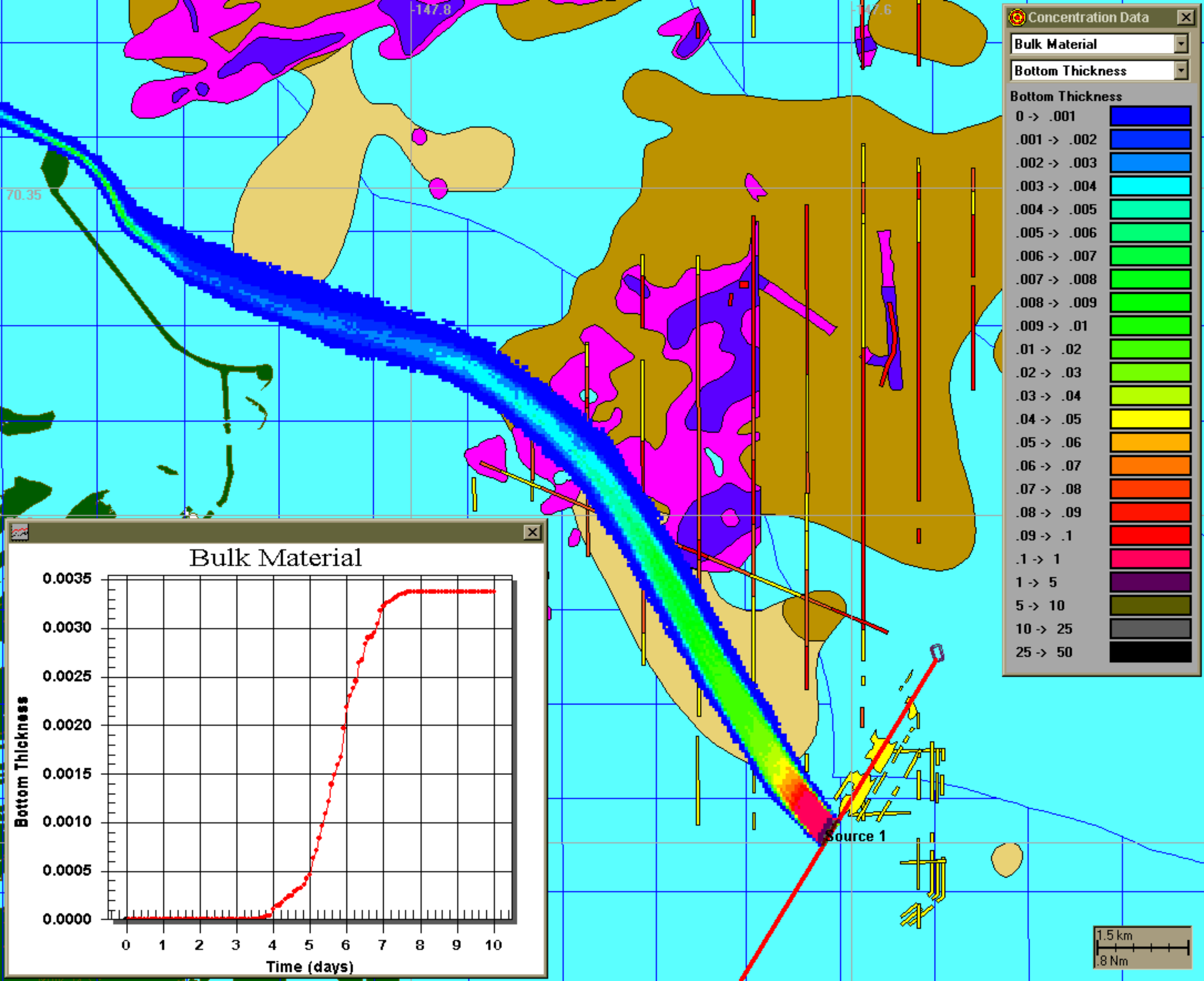

Concentration Data

Bulk Material

Bottom Thickness

Bottom Thickness

0 -> .001	[Blue]
.001 -> .002	[Light Blue]
.002 -> .003	[Cyan]
.003 -> .004	[Green-Cyan]
.004 -> .005	[Green]
.005 -> .006	[Light Green]
.006 -> .007	[Yellow-Green]
.007 -> .008	[Yellow]
.008 -> .009	[Orange-Yellow]
.009 -> .01	[Orange]
.01 -> .02	[Red-Orange]
.02 -> .03	[Red]
.03 -> .04	[Dark Red]
.04 -> .05	[Magenta]
.05 -> .06	[Purple-Magenta]
.06 -> .07	[Purple]
.07 -> .08	[Dark Purple]
.08 -> .09	[Black-Purple]
.09 -> .1	[Black]
.1 -> 1	[Dark Grey]
1 -> 5	[Grey]
5 -> 10	[Light Grey]
10 -> 25	[White-Grey]
25 -> 50	[White]

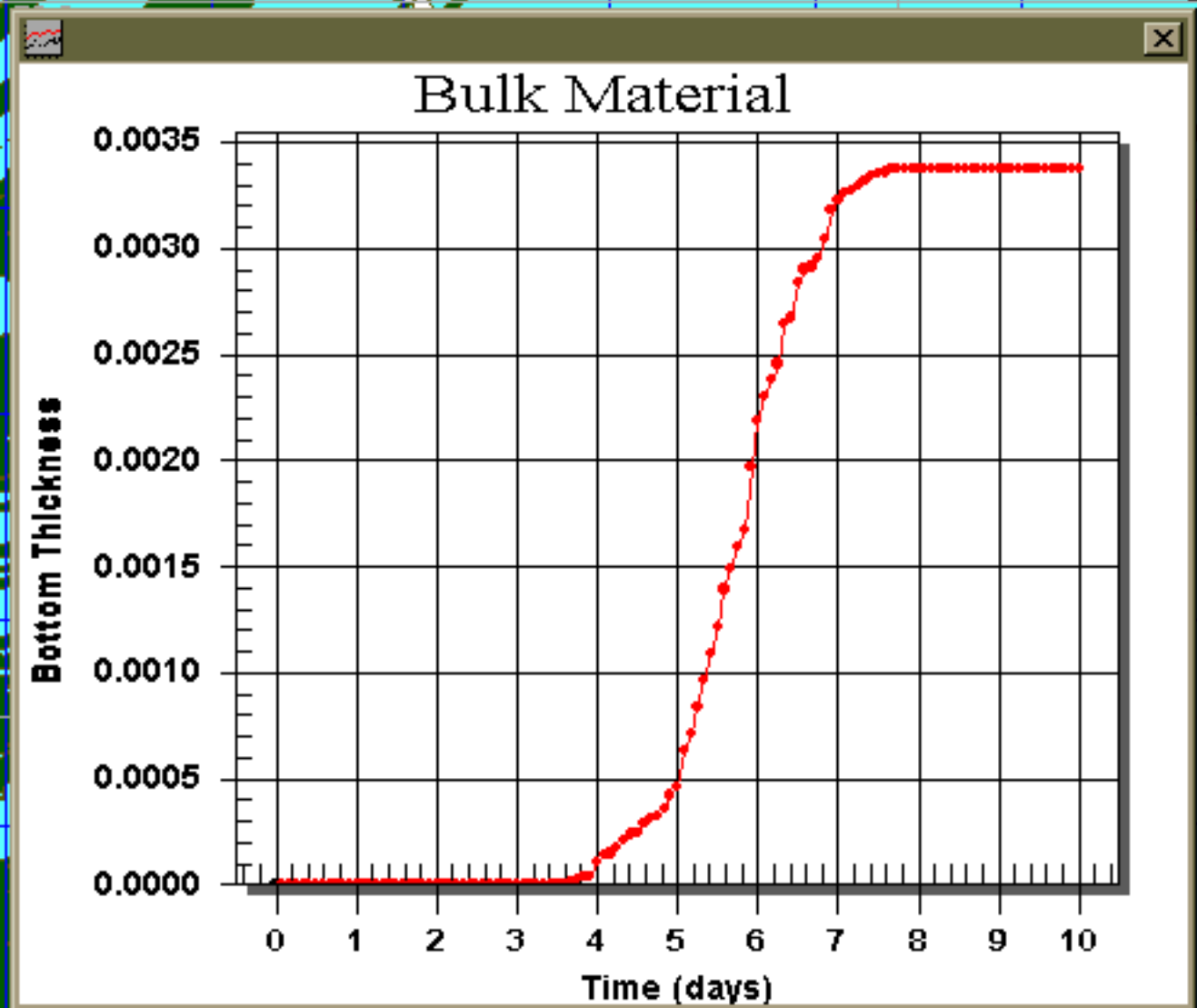

1.5 km
.8 Nm

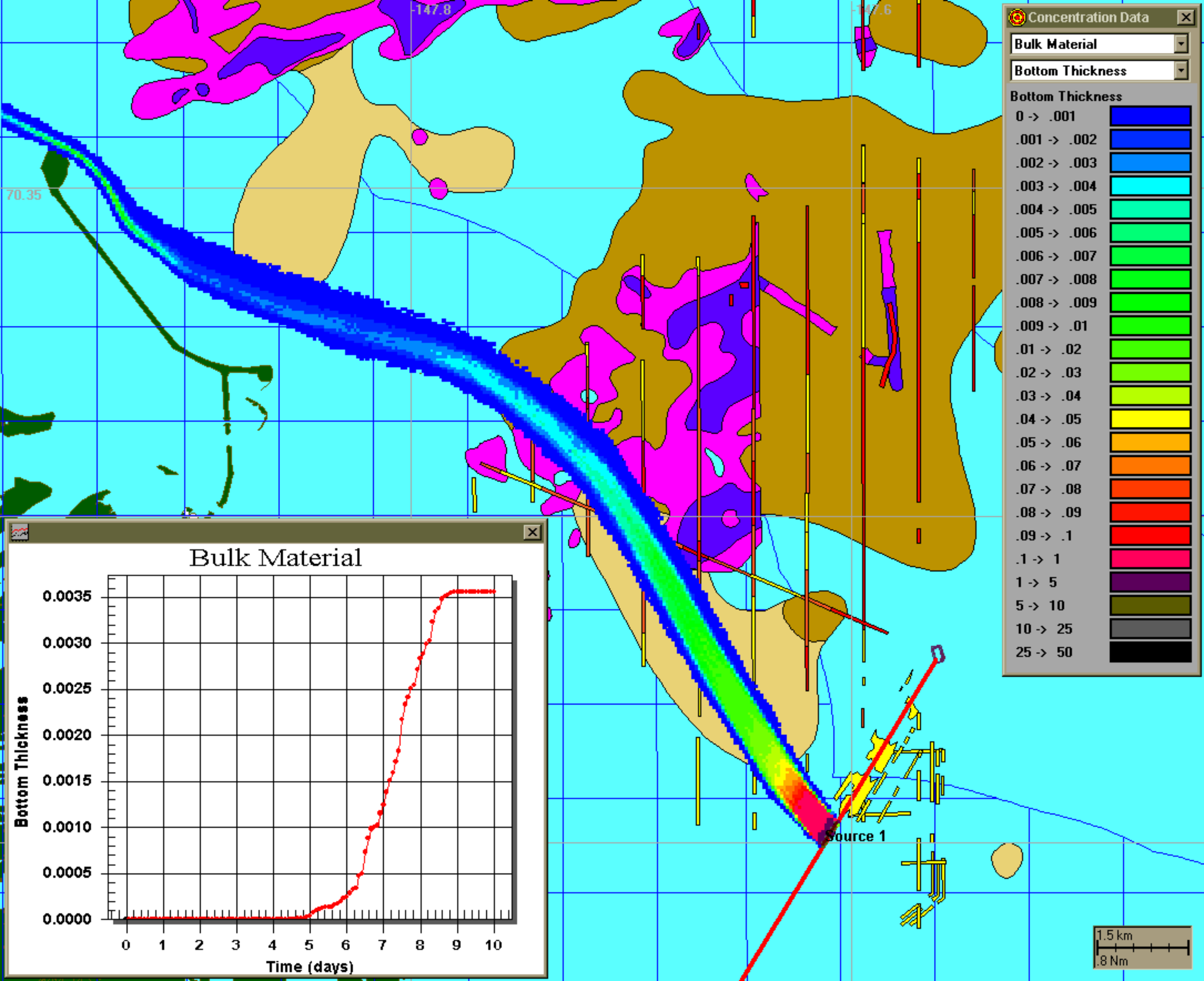

Concentration Data

Bulk Material

Bottom Thickness

Bottom Thickness

0 -> .001	[Dark Blue]
.001 -> .002	[Blue]
.002 -> .003	[Light Blue]
.003 -> .004	[Cyan]
.004 -> .005	[Green-Cyan]
.005 -> .006	[Green]
.006 -> .007	[Light Green]
.007 -> .008	[Green]
.008 -> .009	[Light Green]
.009 -> .01	[Green]
.01 -> .02	[Light Green]
.02 -> .03	[Yellow-Green]
.03 -> .04	[Yellow]
.04 -> .05	[Light Yellow]
.05 -> .06	[Orange]
.06 -> .07	[Red-Orange]
.07 -> .08	[Red]
.08 -> .09	[Dark Red]
.09 -> .1	[Red]
.1 -> 1	[Magenta]
1 -> 5	[Purple]
5 -> 10	[Olive Green]
10 -> 25	[Grey]
25 -> 50	[Black]

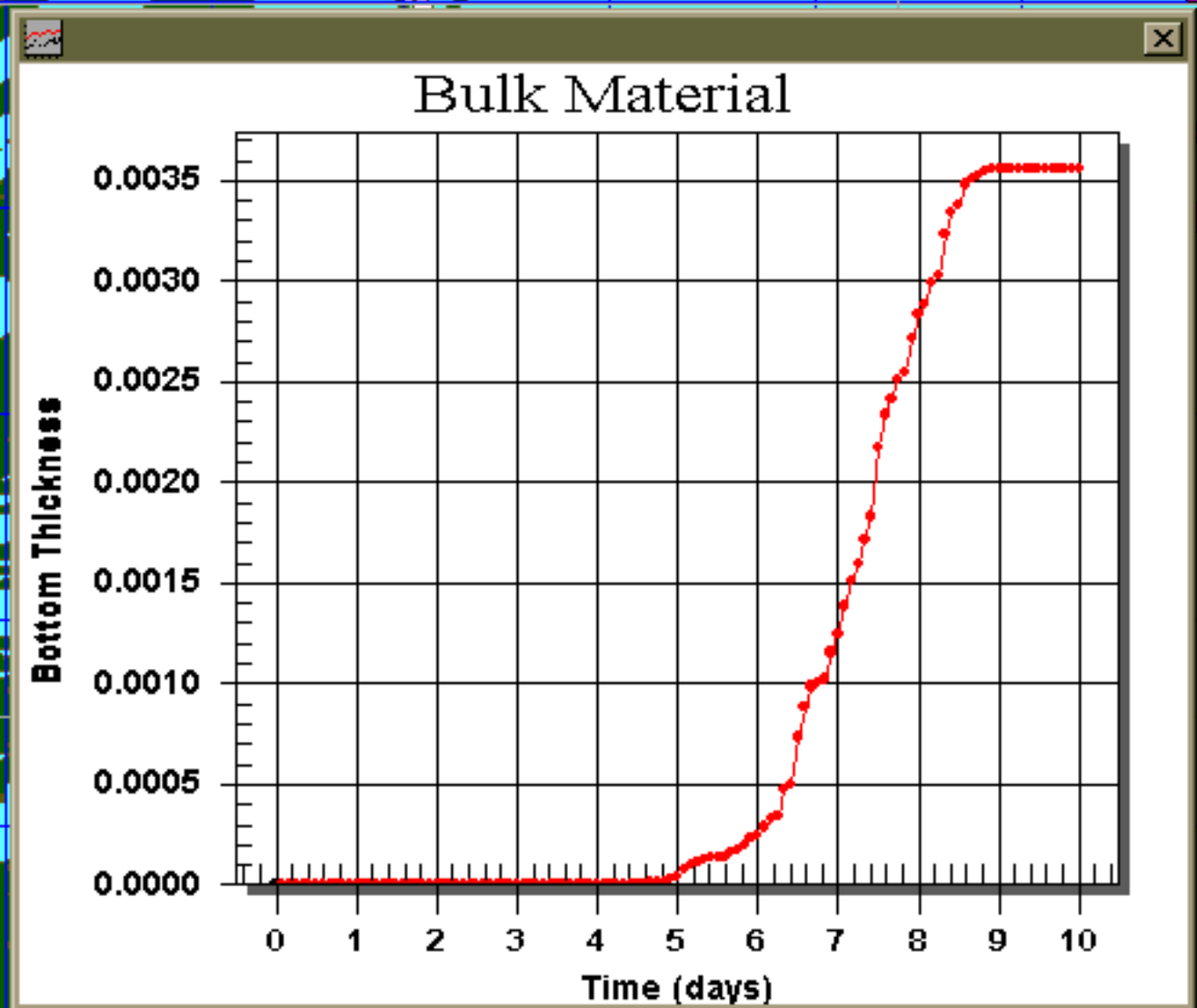

1.5 km
0.8 Nm

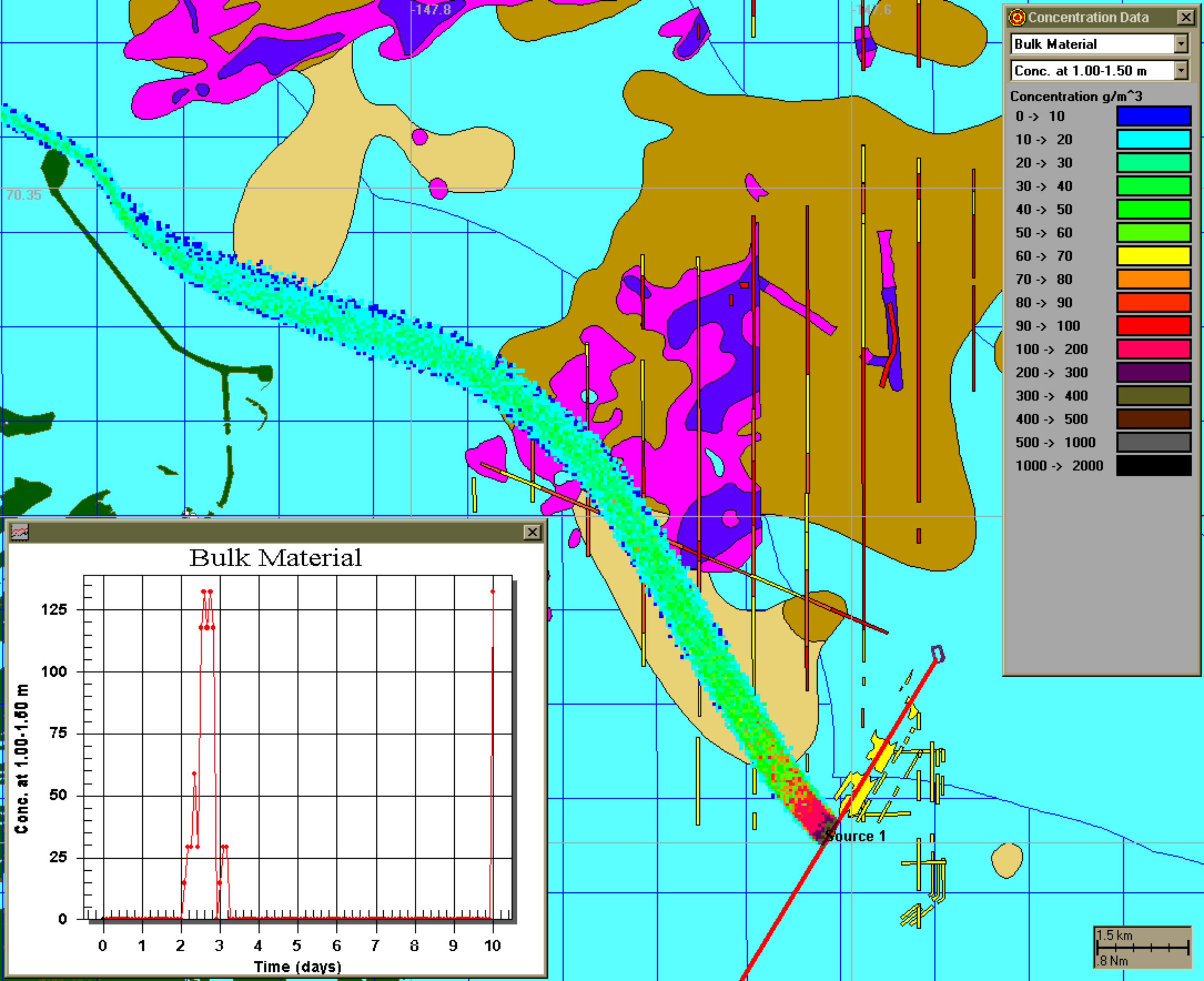

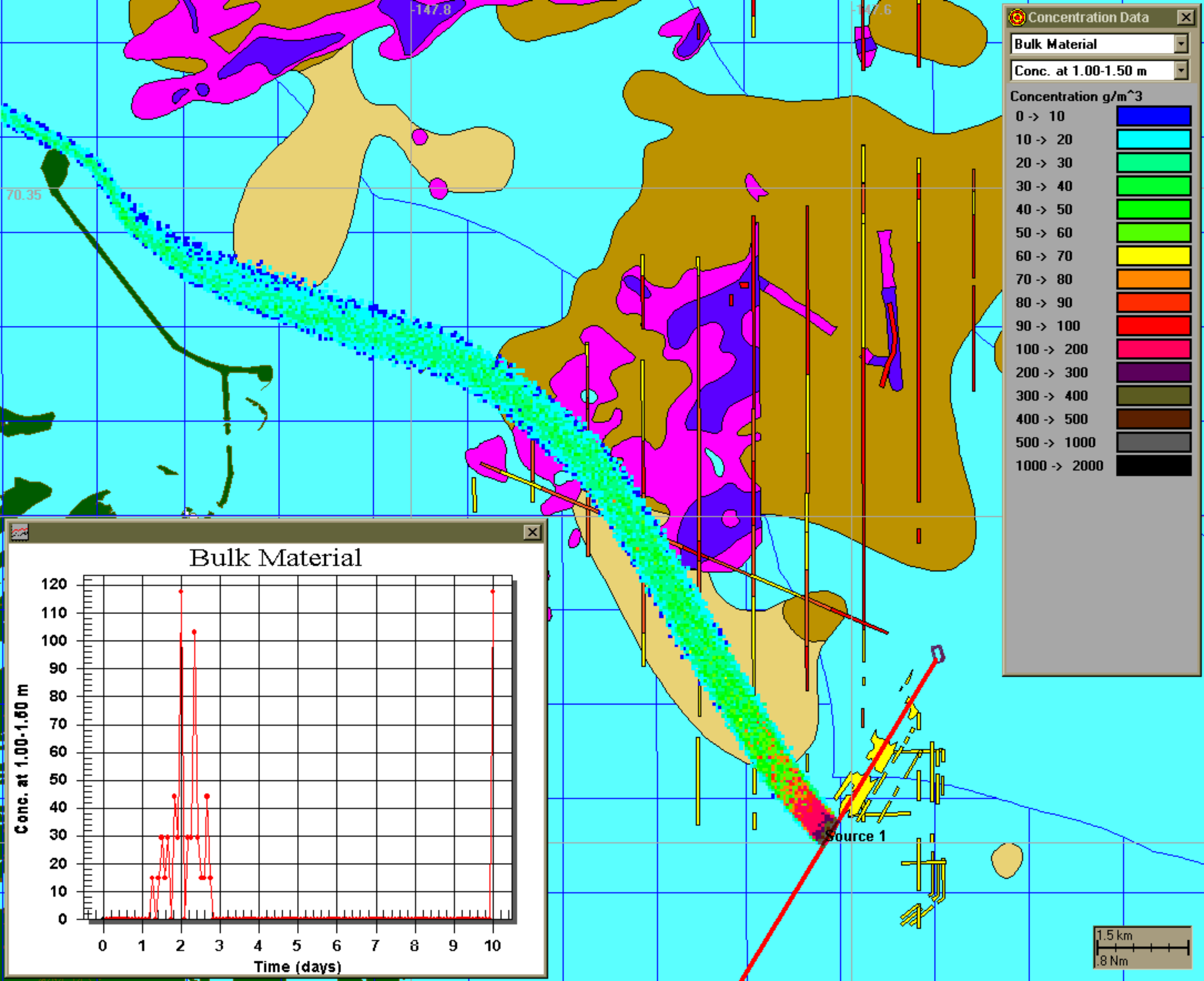

Concentration Data

Bulk Material

Conc. at 1.00-1.50 m

Concentration g/m³

0 -> 10	Blue
10 -> 20	Cyan
20 -> 30	Light Green
30 -> 40	Green
40 -> 50	Bright Green
50 -> 60	Yellow-Green
60 -> 70	Yellow
70 -> 80	Orange
80 -> 90	Red-Orange
90 -> 100	Red
100 -> 200	Magenta
200 -> 300	Purple
300 -> 400	Olive
400 -> 500	Brown
500 -> 1000	Grey
1000 -> 2000	Black

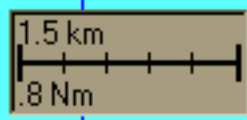
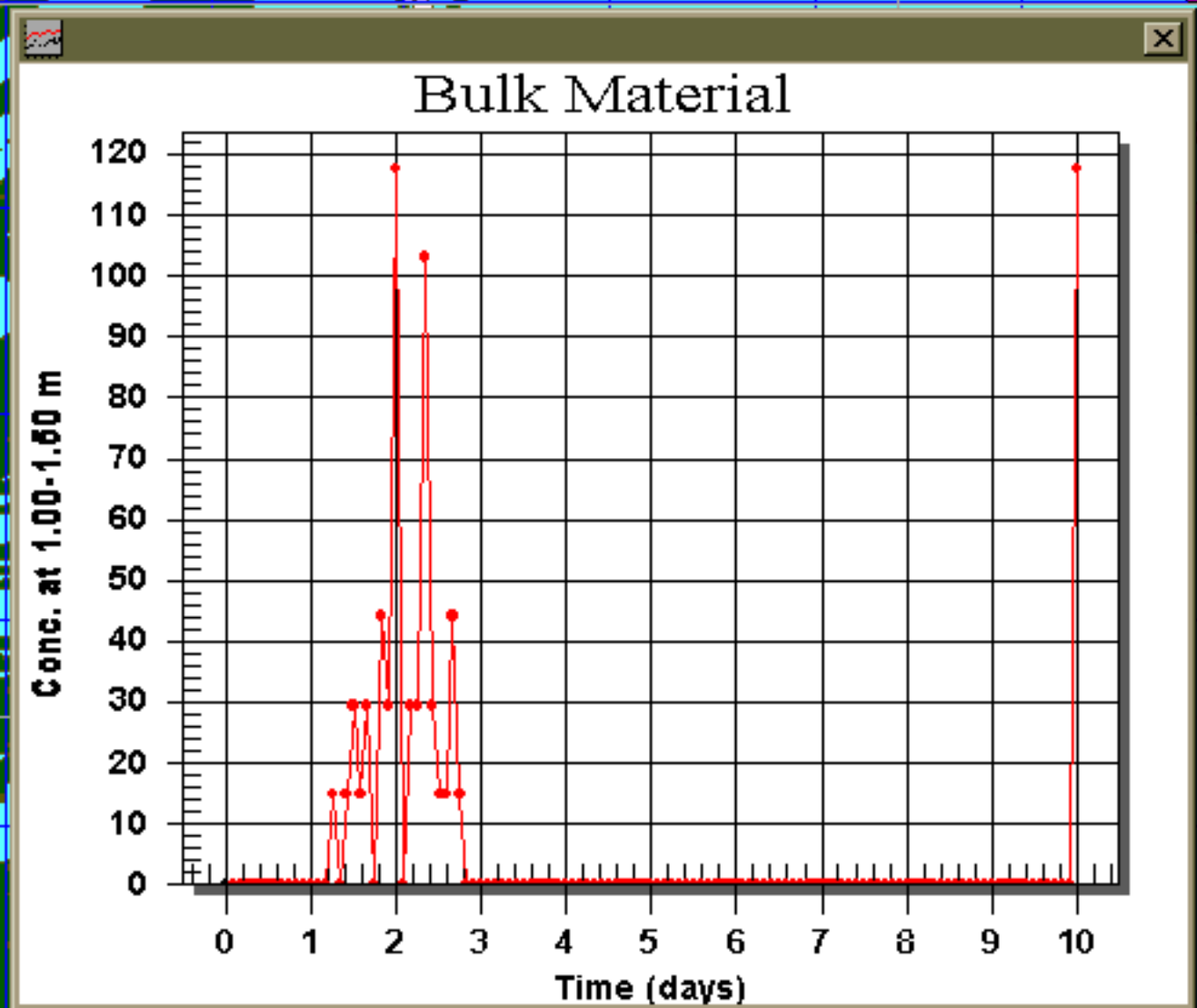

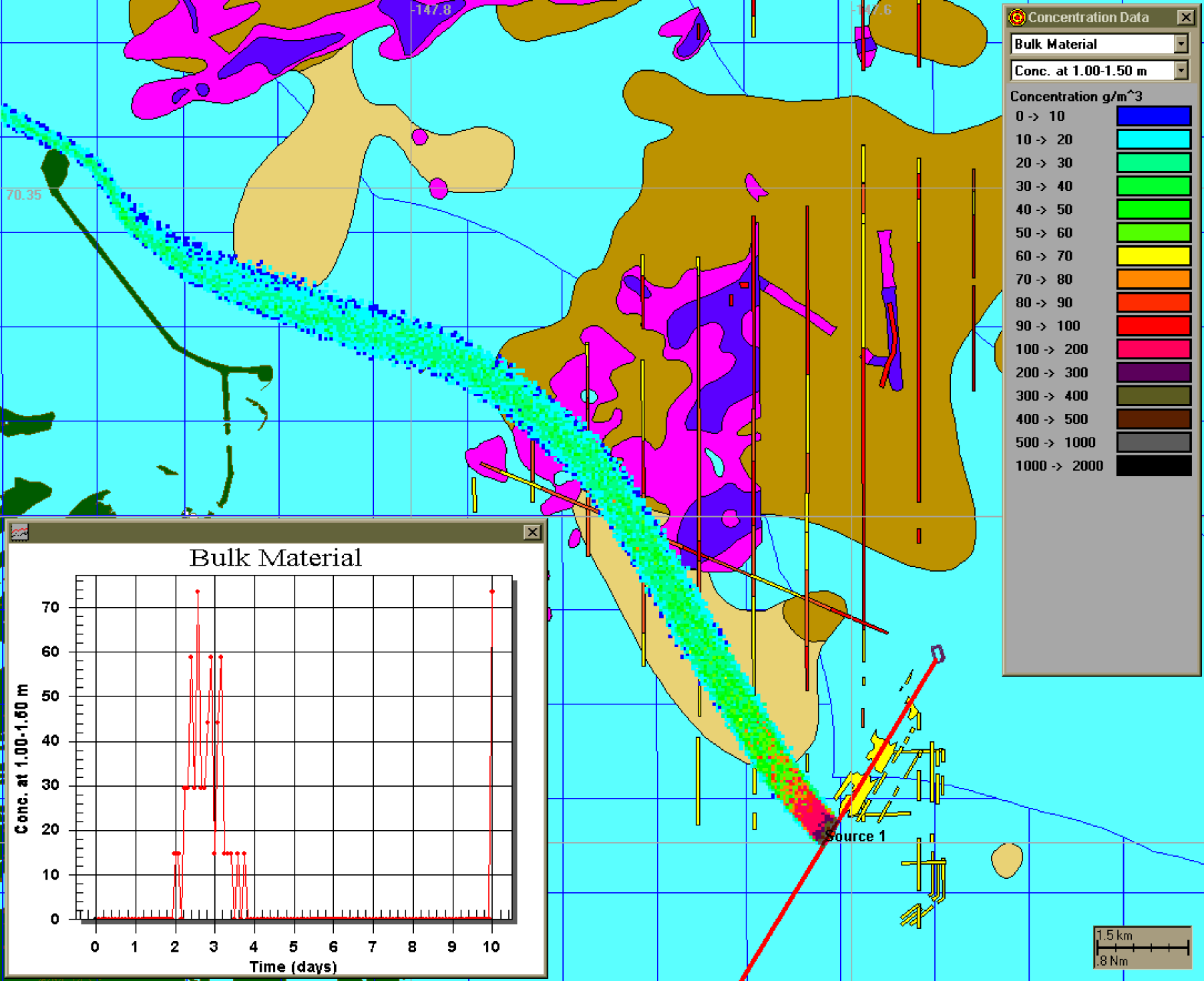

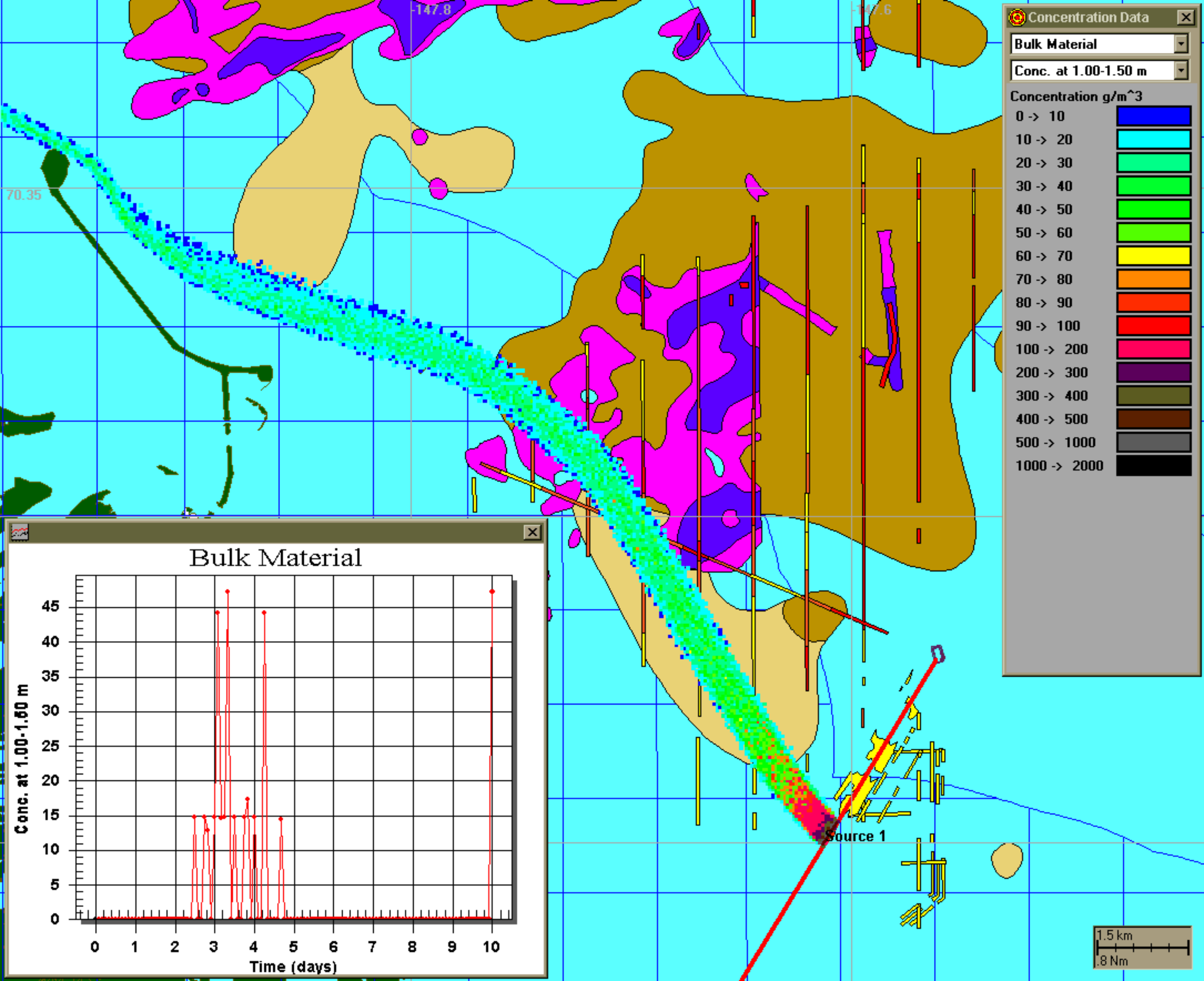

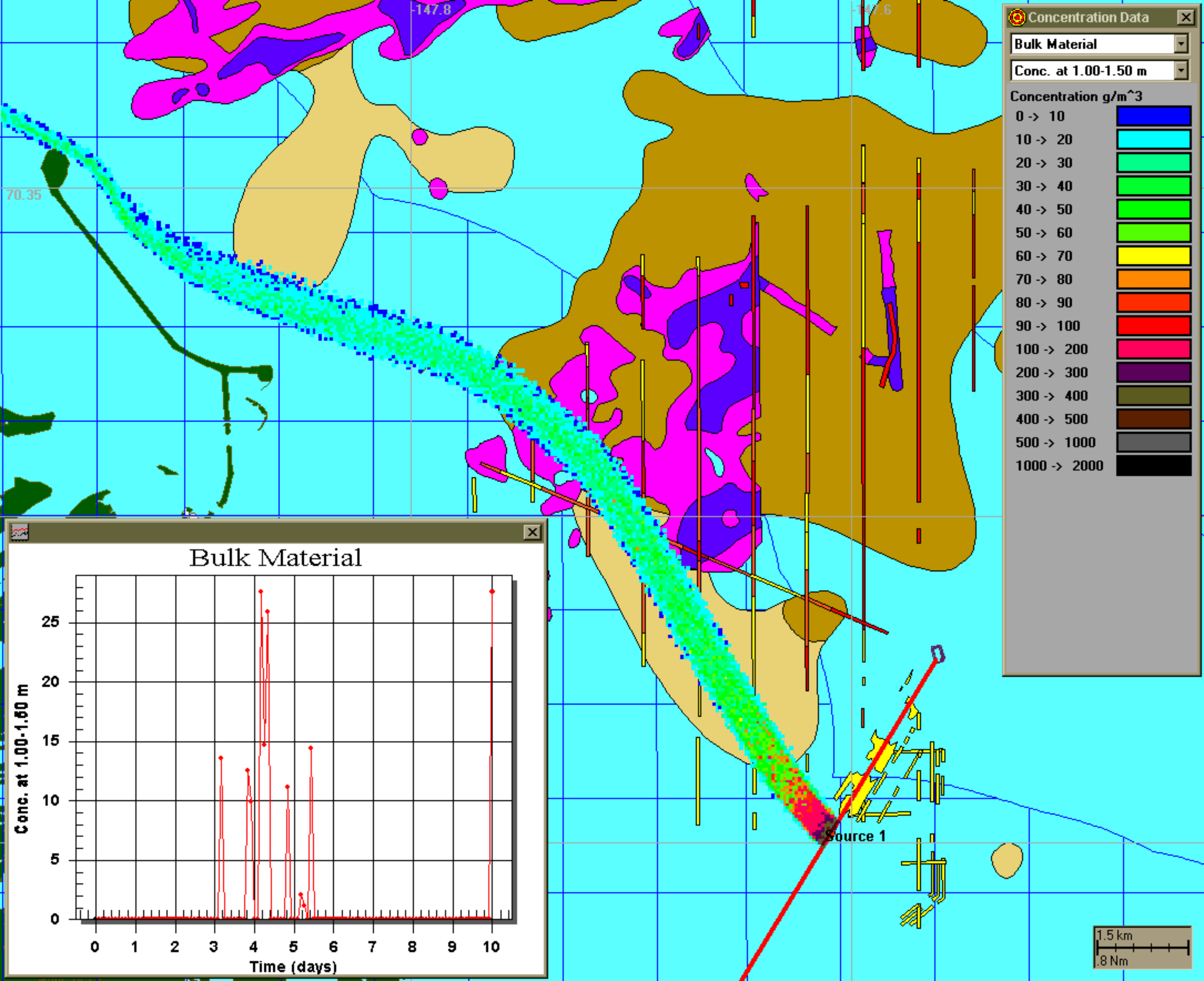

Concentration Data

Bulk Material

Conc. at 1.00-1.50 m

Concentration g/m³

0 -> 10	Blue
10 -> 20	Cyan
20 -> 30	Light Green
30 -> 40	Green
40 -> 50	Bright Green
50 -> 60	Yellow-Green
60 -> 70	Yellow
70 -> 80	Orange
80 -> 90	Red-Orange
90 -> 100	Red
100 -> 200	Magenta
200 -> 300	Purple
300 -> 400	Olive
400 -> 500	Brown
500 -> 1000	Grey
1000 -> 2000	Black

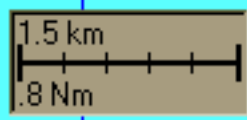
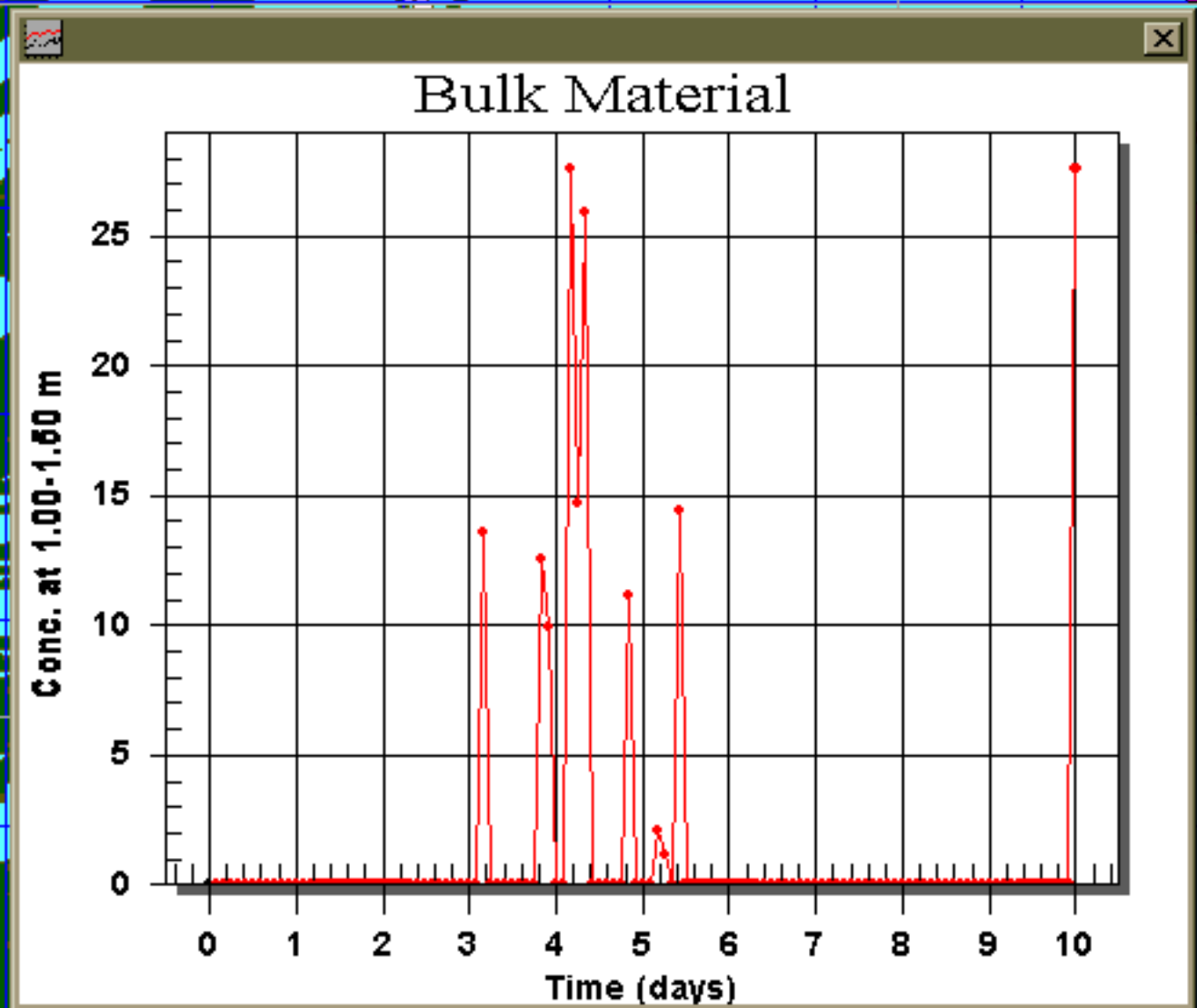

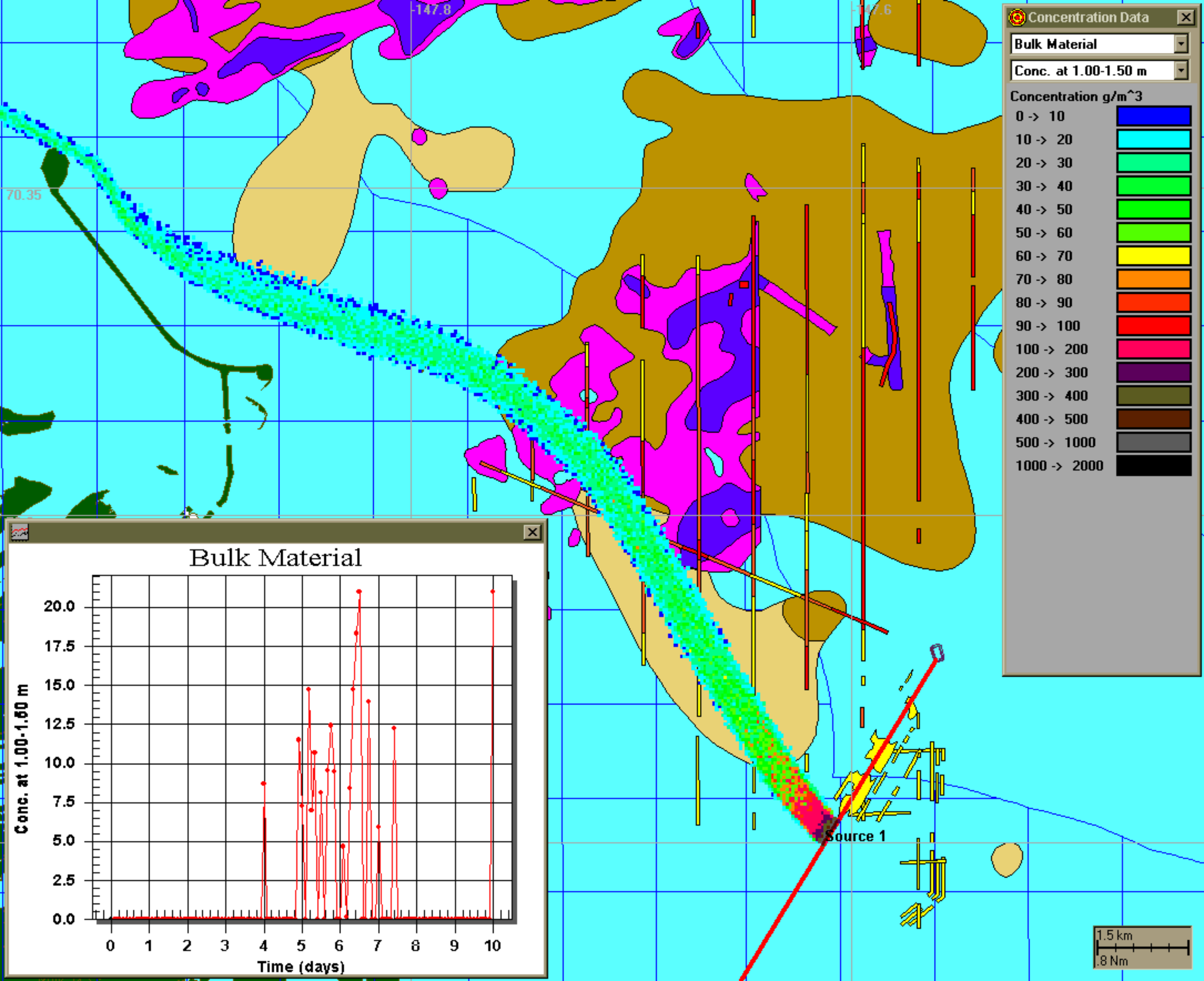

Concentration Data

Bulk Material

Conc. at 1.00-1.50 m

Concentration g/m³

0 -> 10	Blue
10 -> 20	Cyan
20 -> 30	Light Green
30 -> 40	Green
40 -> 50	Bright Green
50 -> 60	Yellow-Green
60 -> 70	Yellow
70 -> 80	Orange
80 -> 90	Red-Orange
90 -> 100	Red
100 -> 200	Magenta
200 -> 300	Purple
300 -> 400	Olive
400 -> 500	Brown
500 -> 1000	Grey
1000 -> 2000	Black

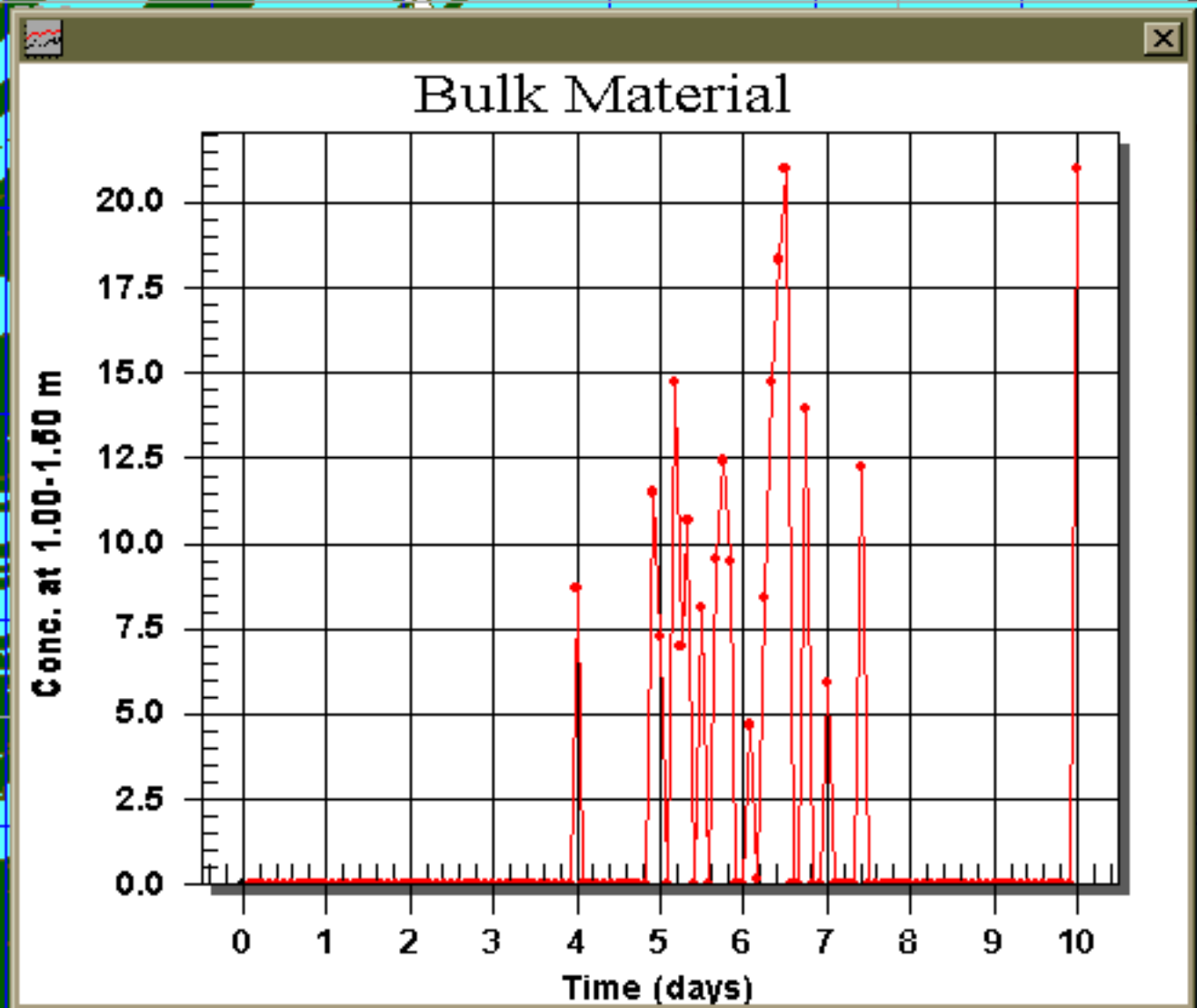

1.5 km
0.8 Nm

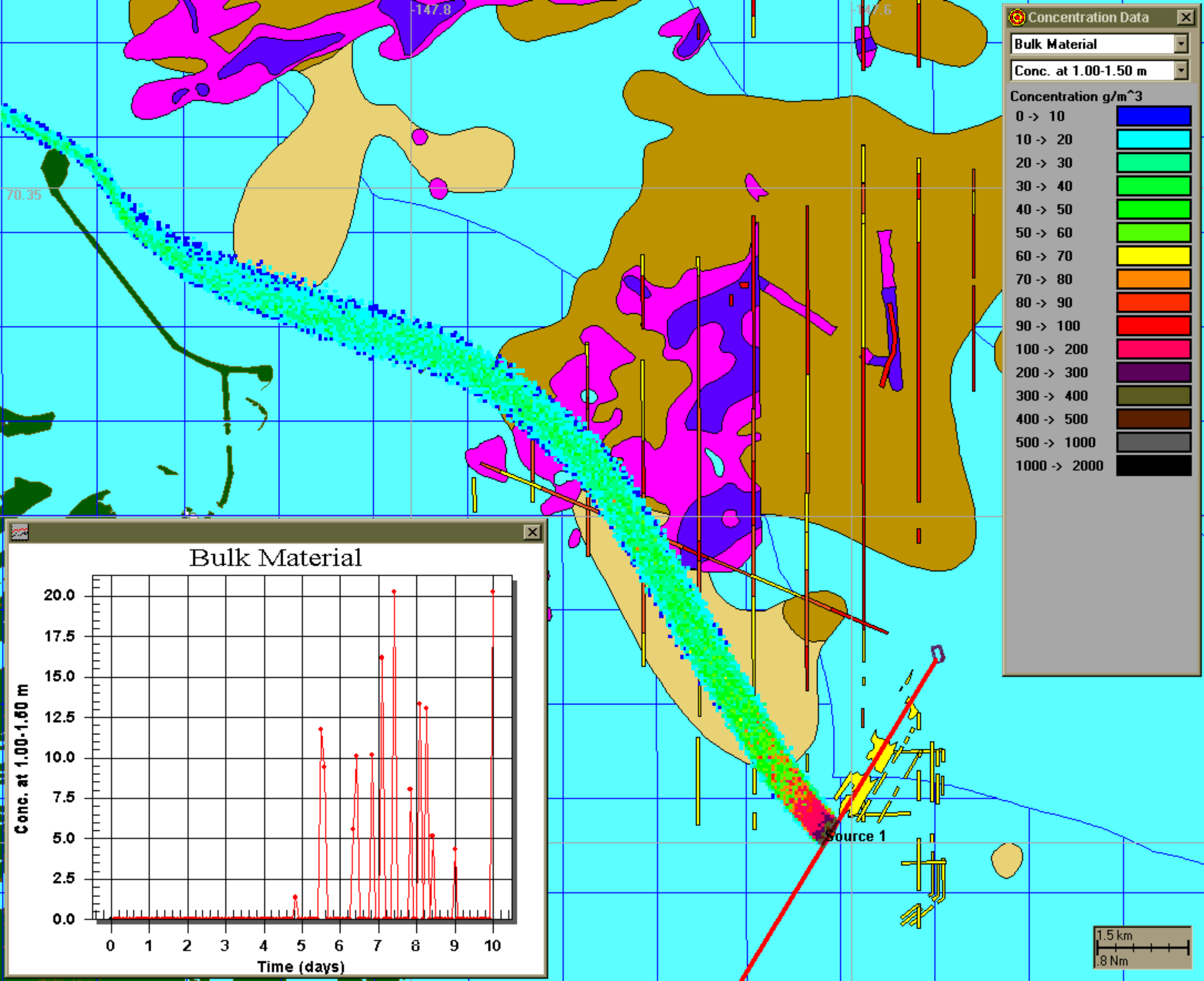

Concentration Data

Bulk Material

Conc. at 1.00-1.50 m

Concentration g/m³

0 -> 10	Blue
10 -> 20	Cyan
20 -> 30	Light Green
30 -> 40	Green
40 -> 50	Bright Green
50 -> 60	Yellow-Green
60 -> 70	Yellow
70 -> 80	Orange
80 -> 90	Red-Orange
90 -> 100	Red
100 -> 200	Magenta
200 -> 300	Purple
300 -> 400	Olive
400 -> 500	Brown
500 -> 1000	Grey
1000 -> 2000	Black

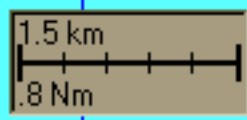
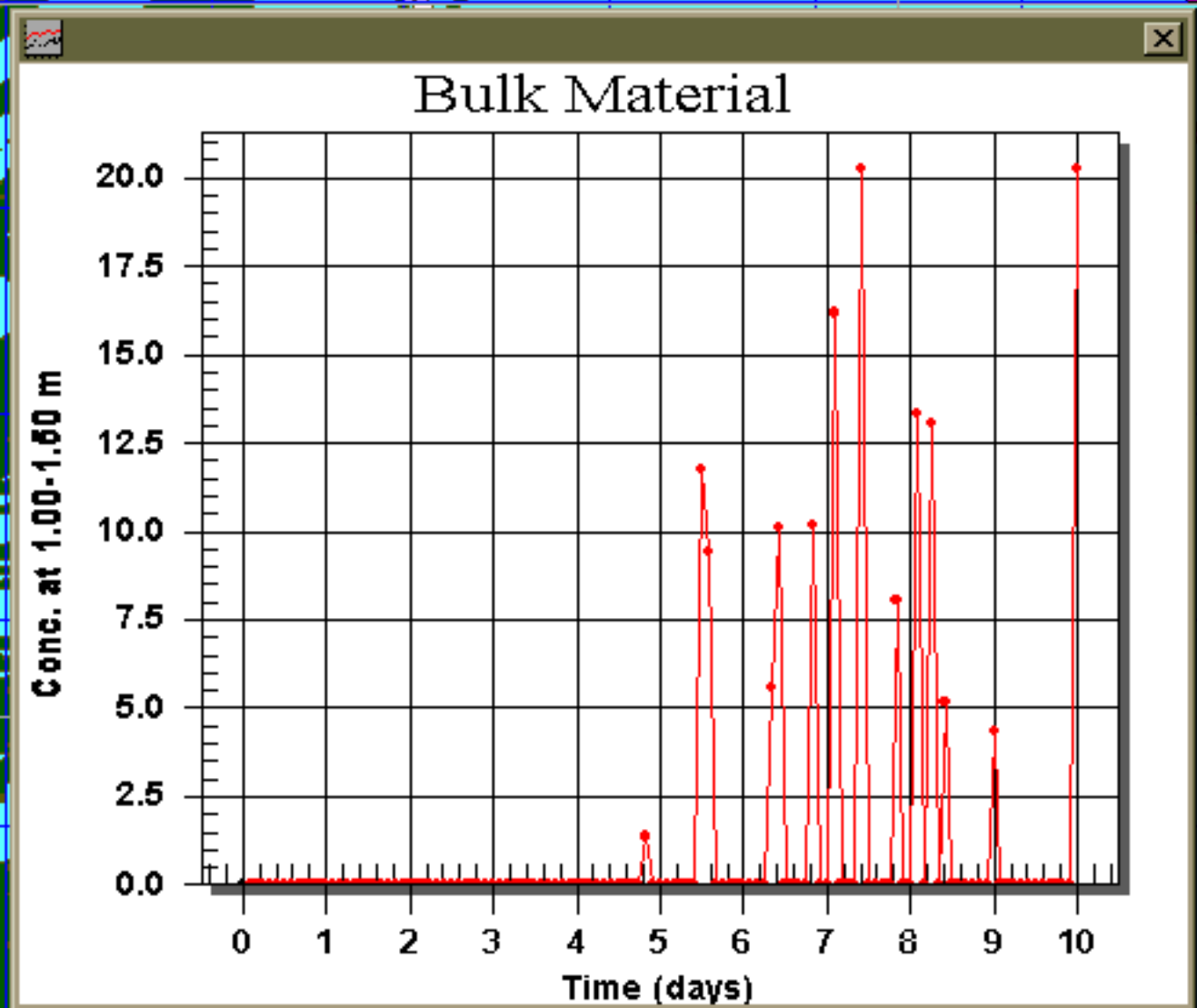

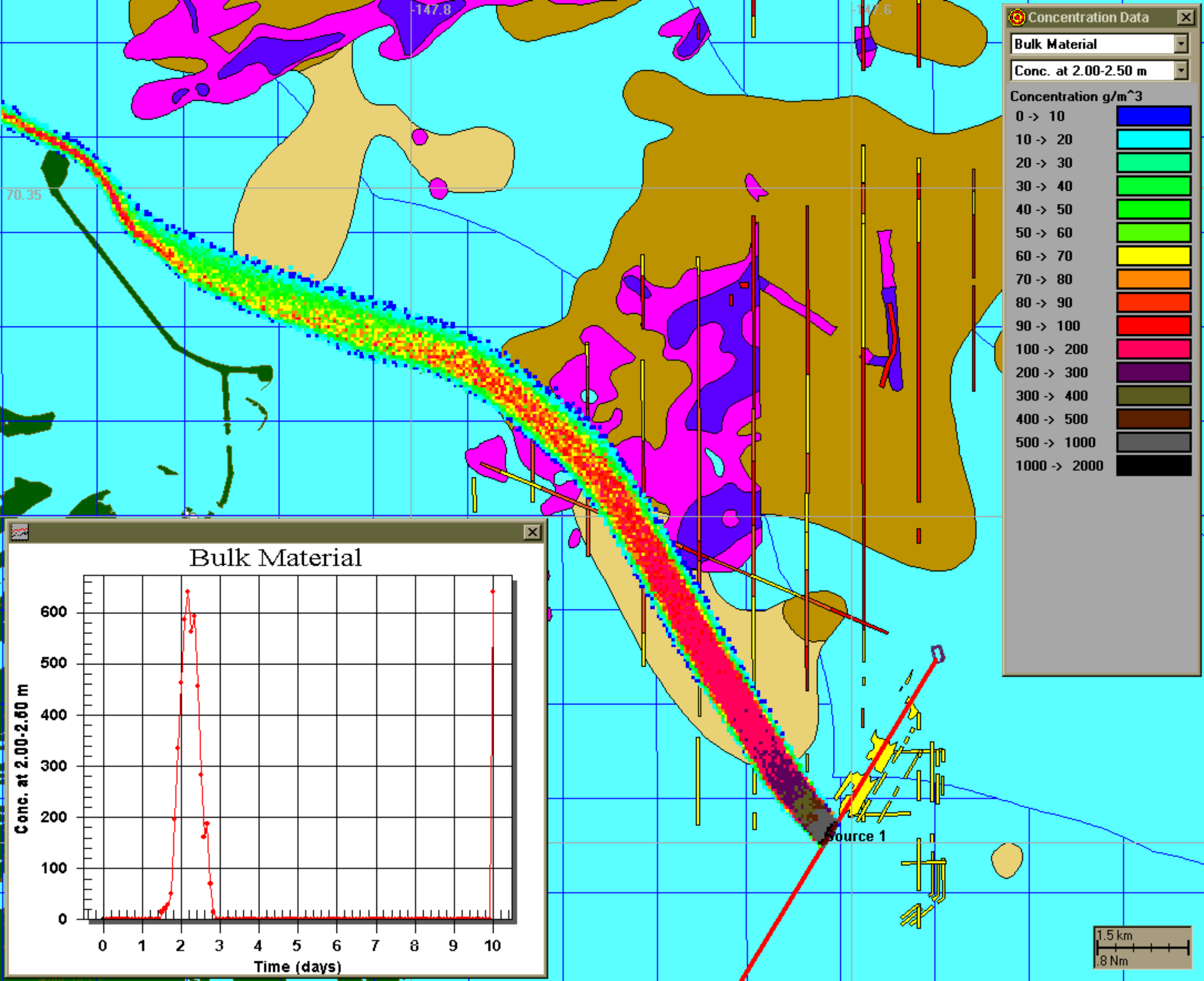

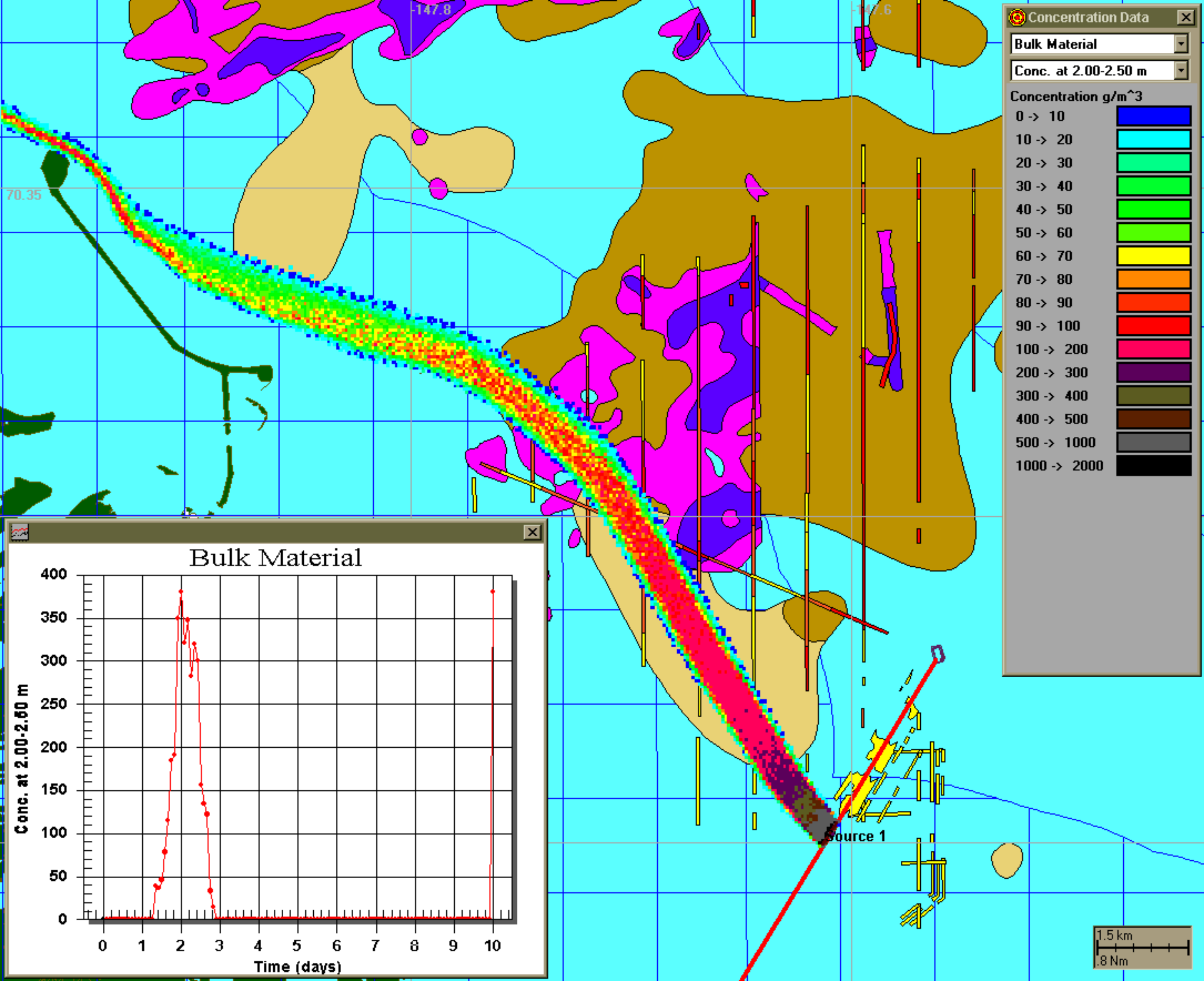

Concentration Data

Bulk Material

Conc. at 2.00-2.50 m

Concentration g/m^3

- 0 -> 10
- 10 -> 20
- 20 -> 30
- 30 -> 40
- 40 -> 50
- 50 -> 60
- 60 -> 70
- 70 -> 80
- 80 -> 90
- 90 -> 100
- 100 -> 200
- 200 -> 300
- 300 -> 400
- 400 -> 500
- 500 -> 1000
- 1000 -> 2000

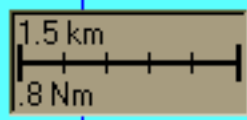
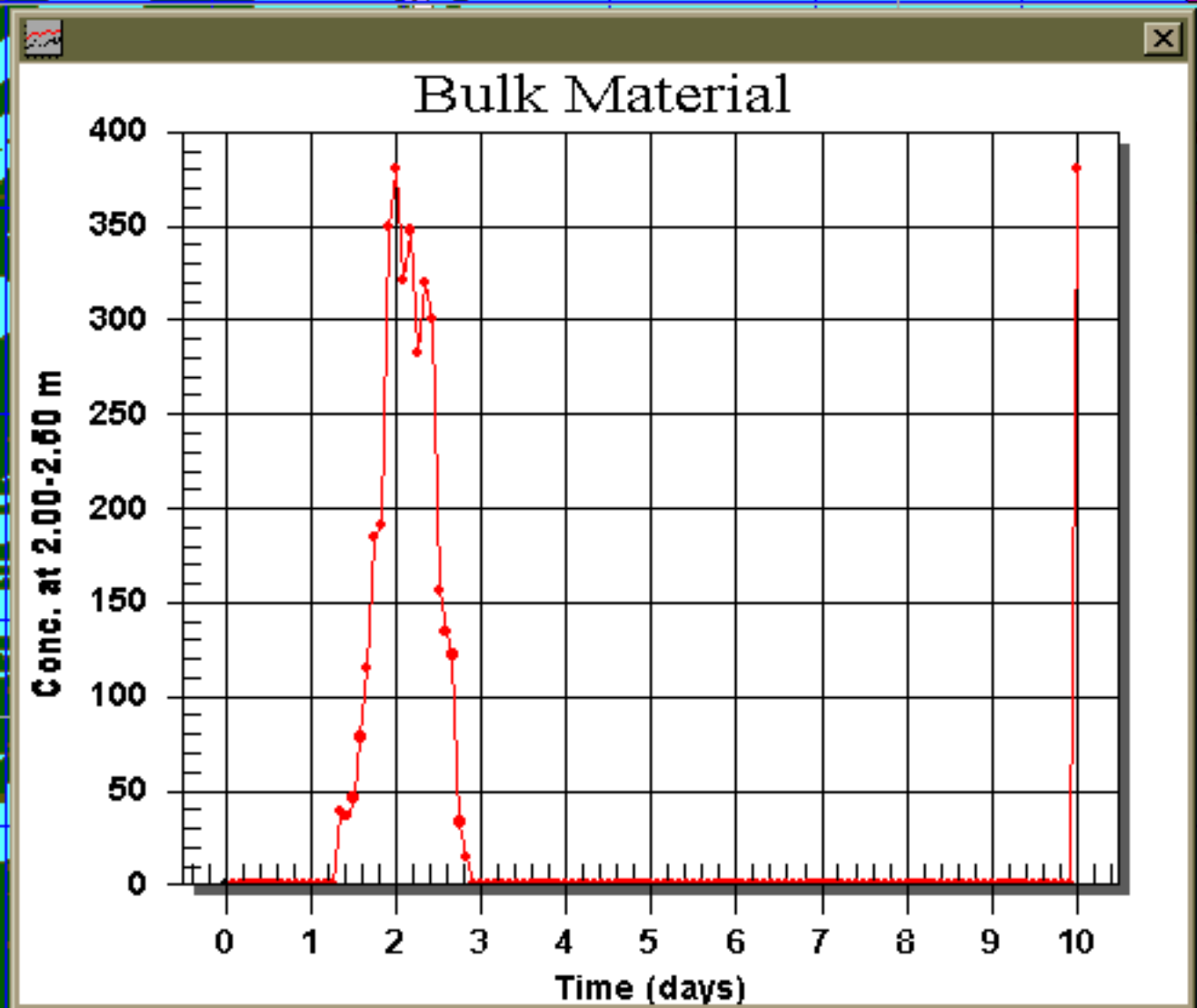

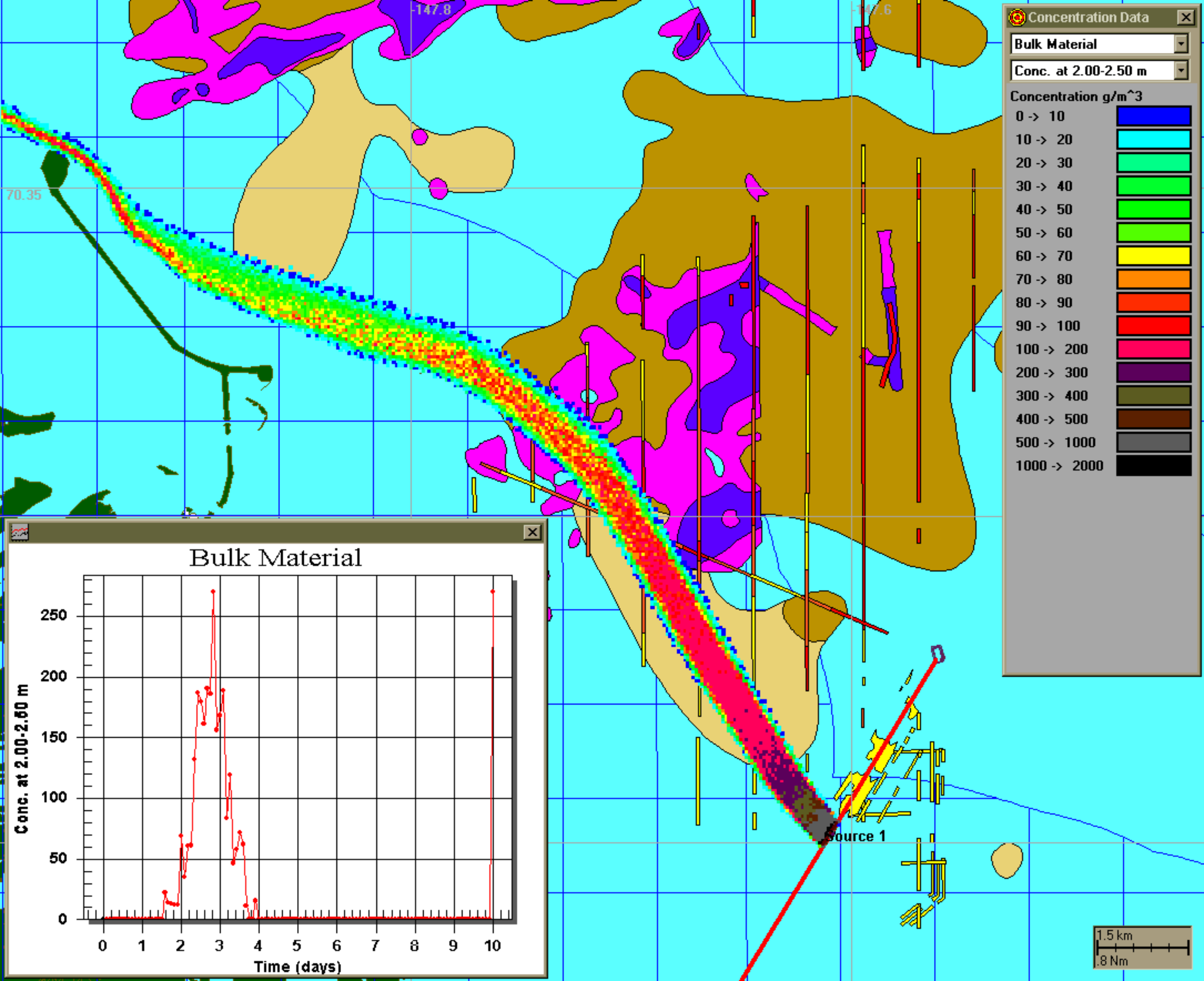

Concentration Data

Bulk Material

Conc. at 2.00-2.50 m

Concentration g/m³

0 -> 10	Blue
10 -> 20	Cyan
20 -> 30	Light Green
30 -> 40	Green
40 -> 50	Bright Green
50 -> 60	Yellow-Green
60 -> 70	Yellow
70 -> 80	Orange
80 -> 90	Red-Orange
90 -> 100	Red
100 -> 200	Magenta
200 -> 300	Purple
300 -> 400	Olive
400 -> 500	Brown
500 -> 1000	Grey
1000 -> 2000	Black

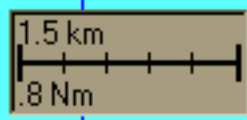
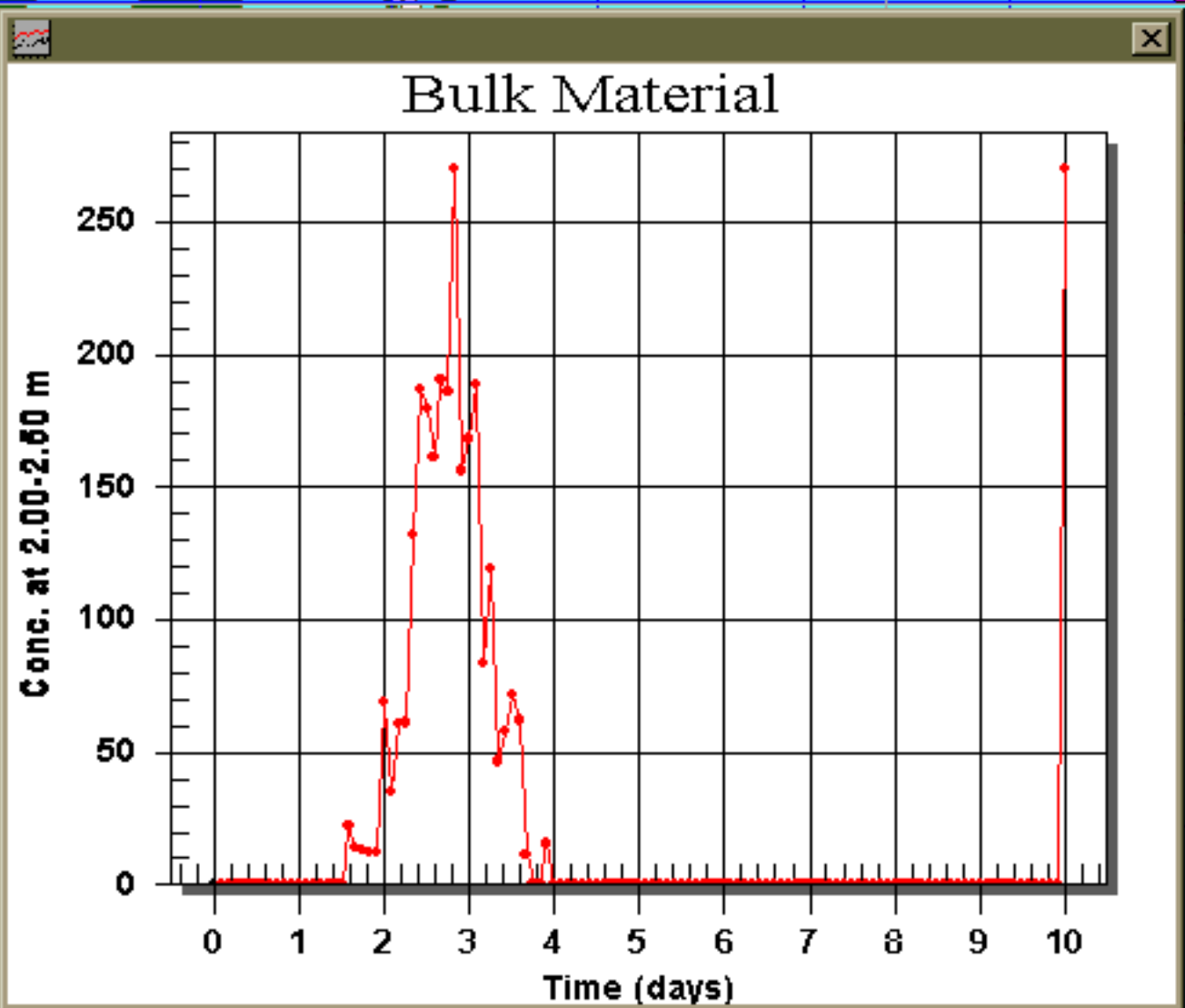

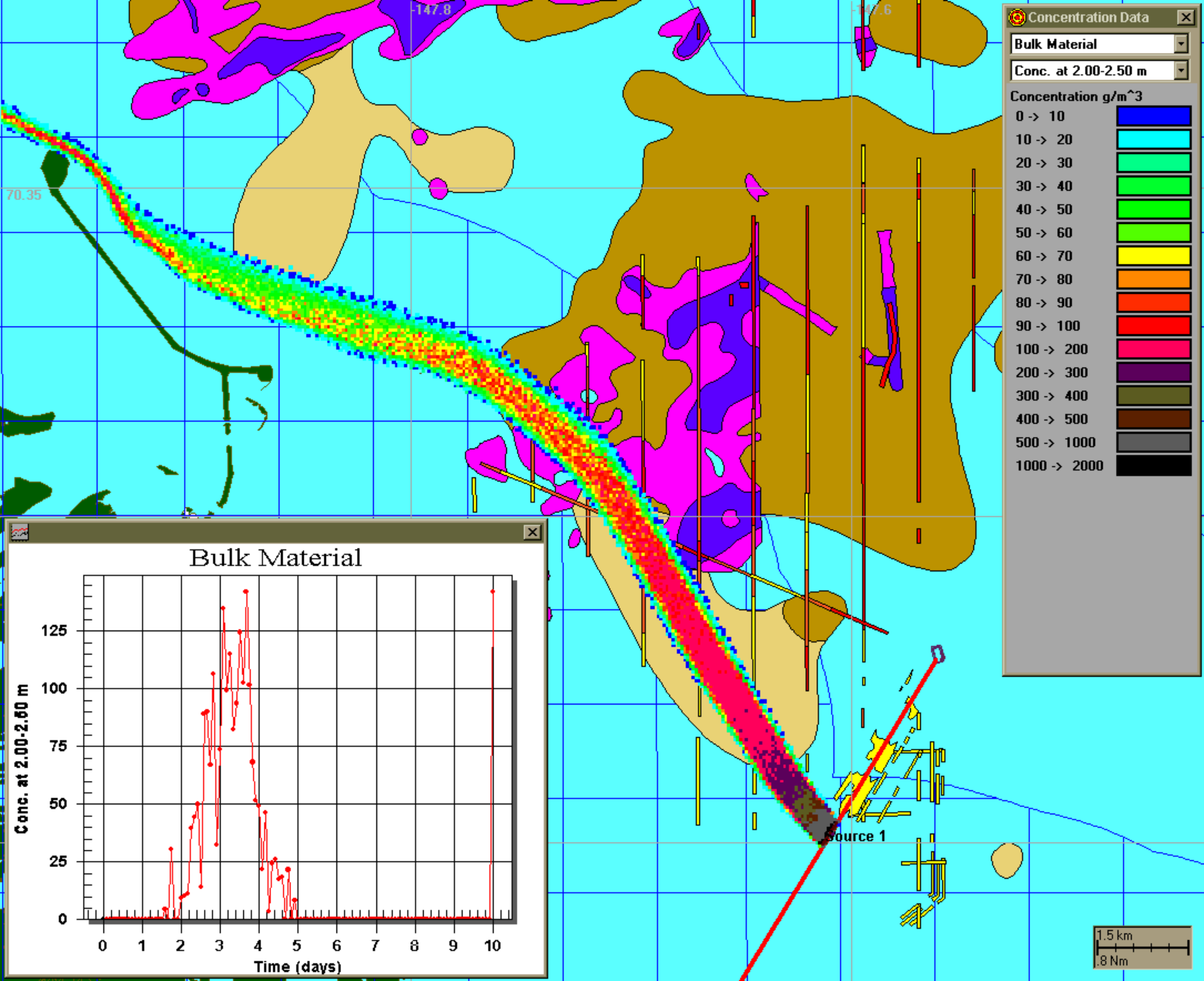

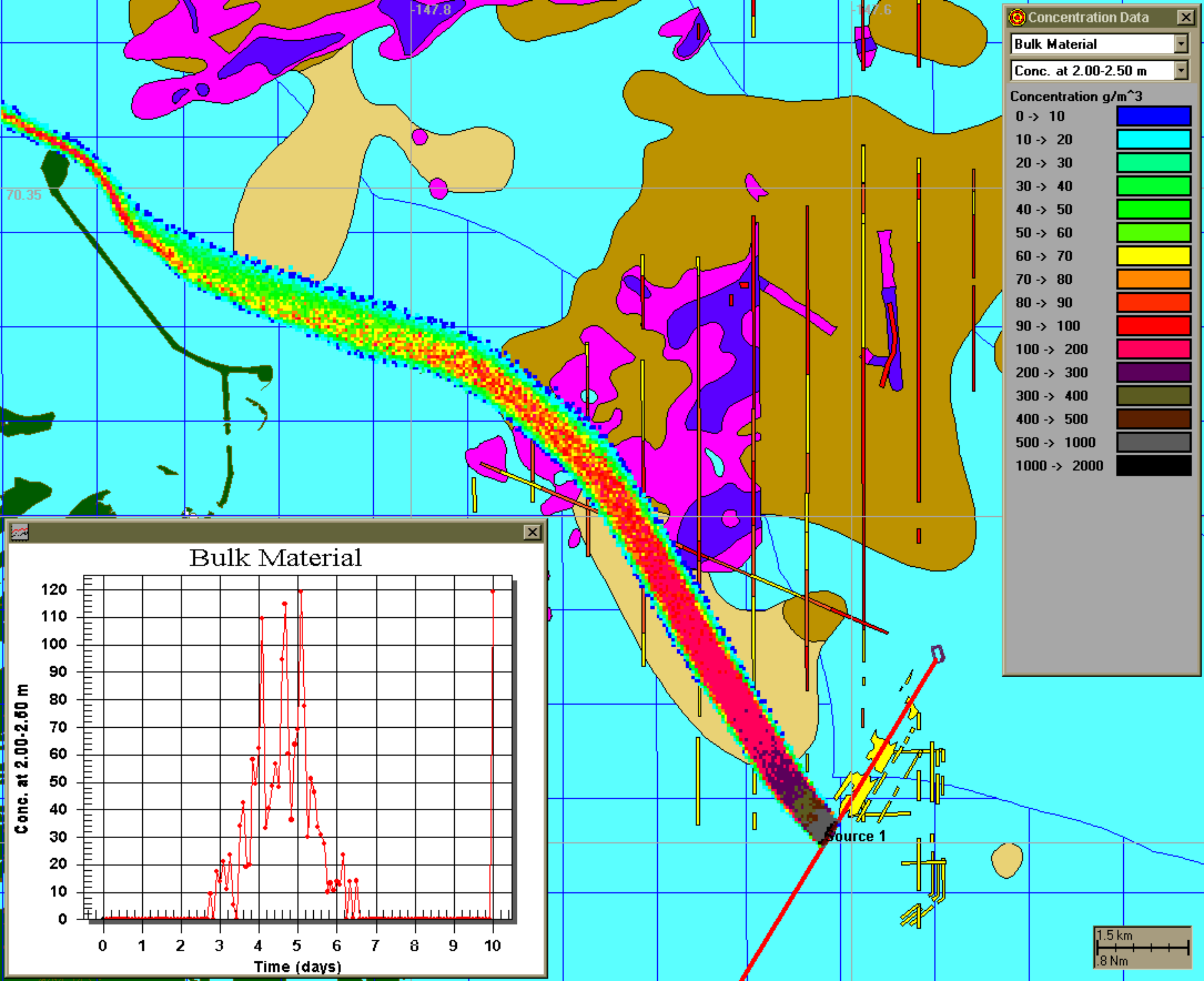

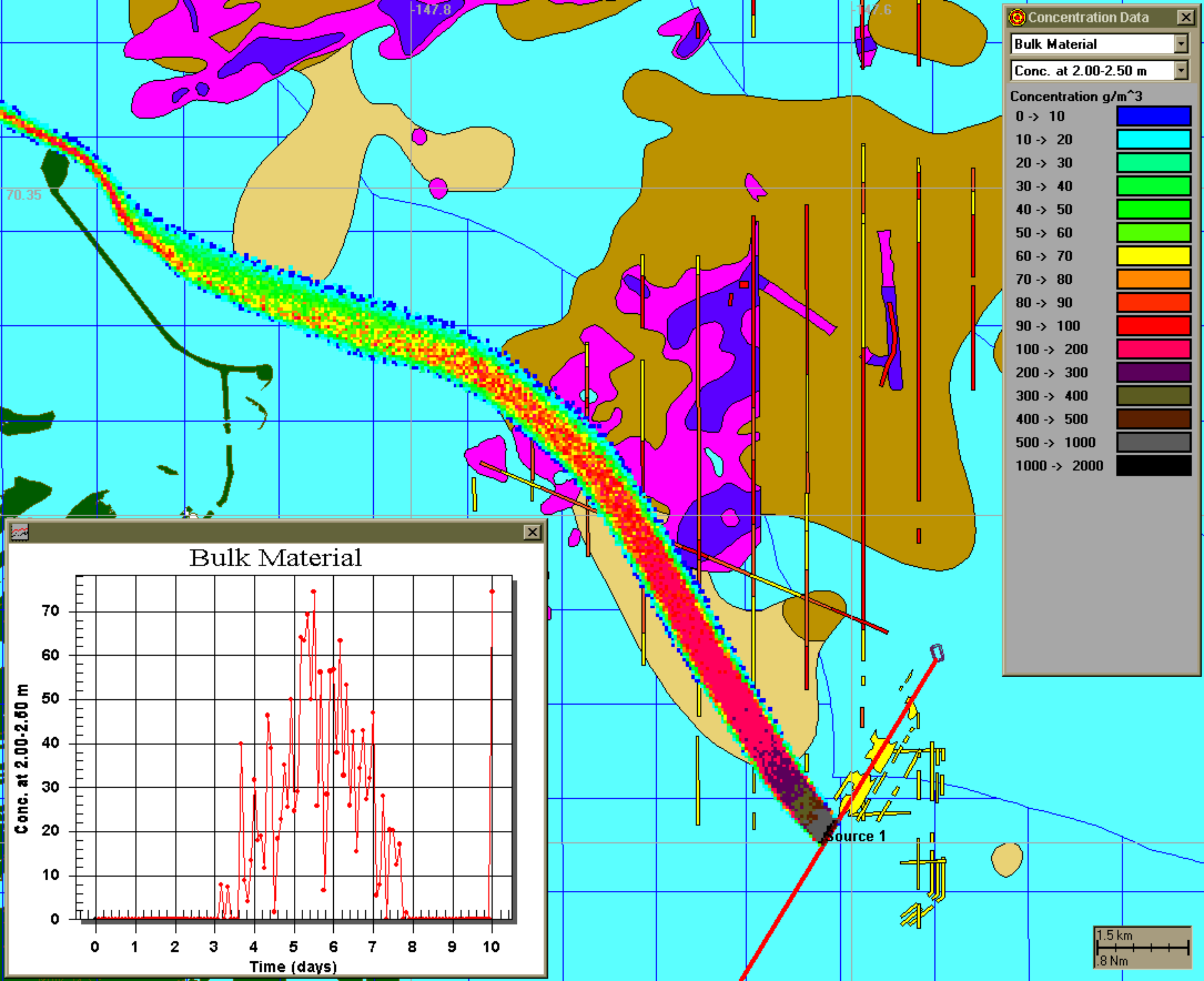

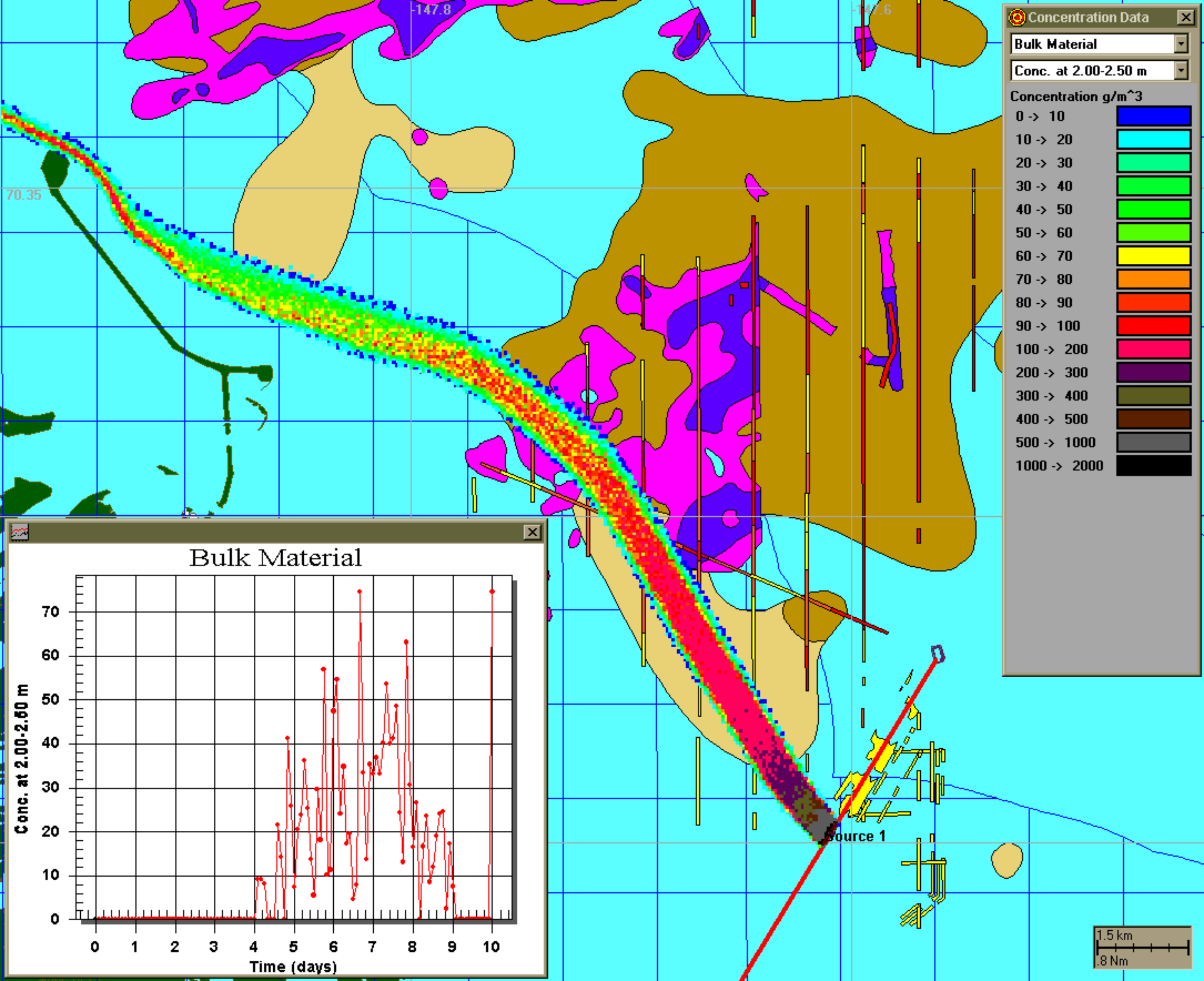

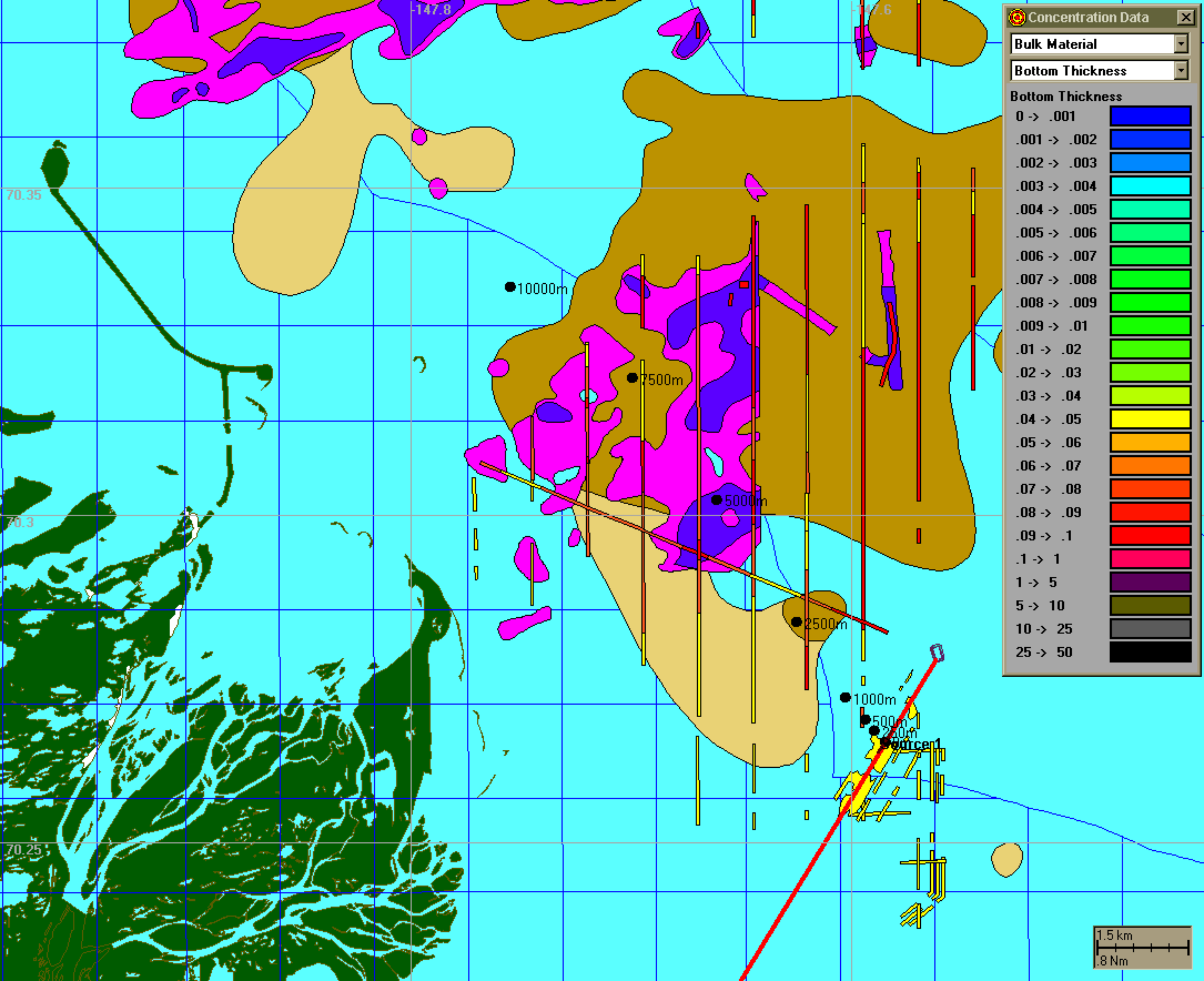

Concentration Data

Bulk Material

Bottom Thickness

Bottom Thickness

0 -> .001	[Blue]
.001 -> .002	[Blue]
.002 -> .003	[Blue]
.003 -> .004	[Cyan]
.004 -> .005	[Cyan]
.005 -> .006	[Green]
.006 -> .007	[Green]
.007 -> .008	[Green]
.008 -> .009	[Green]
.009 -> .01	[Green]
.01 -> .02	[Light Green]
.02 -> .03	[Light Green]
.03 -> .04	[Yellow-Green]
.04 -> .05	[Yellow]
.05 -> .06	[Yellow-Orange]
.06 -> .07	[Orange]
.07 -> .08	[Orange-Red]
.08 -> .09	[Red-Orange]
.09 -> .1	[Red]
.1 -> 1	[Red]
1 -> 5	[Magenta]
5 -> 10	[Purple]
10 -> 25	[Brown]
25 -> 50	[Black]

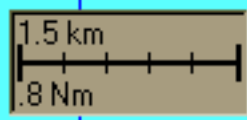

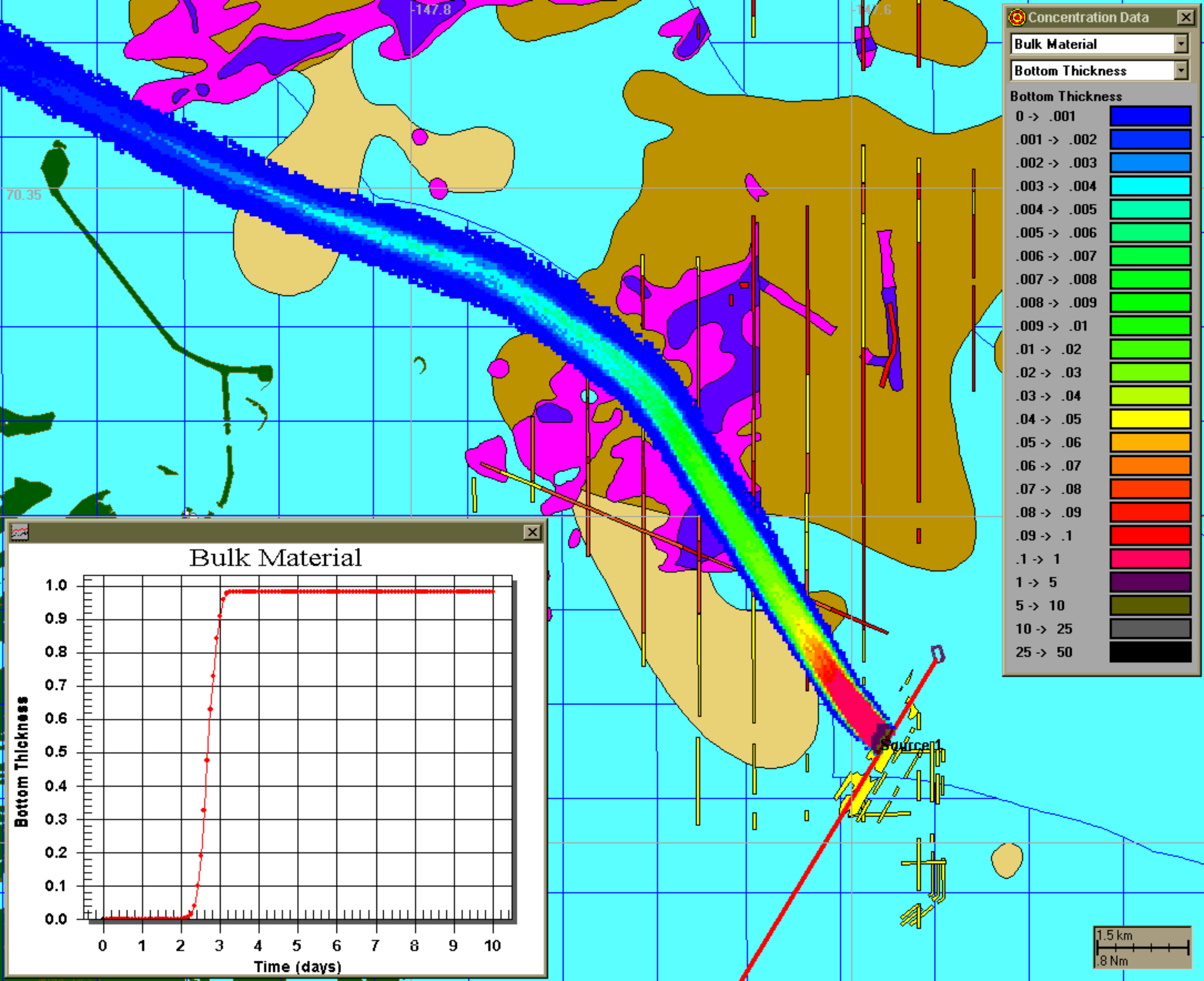

Bulk Material

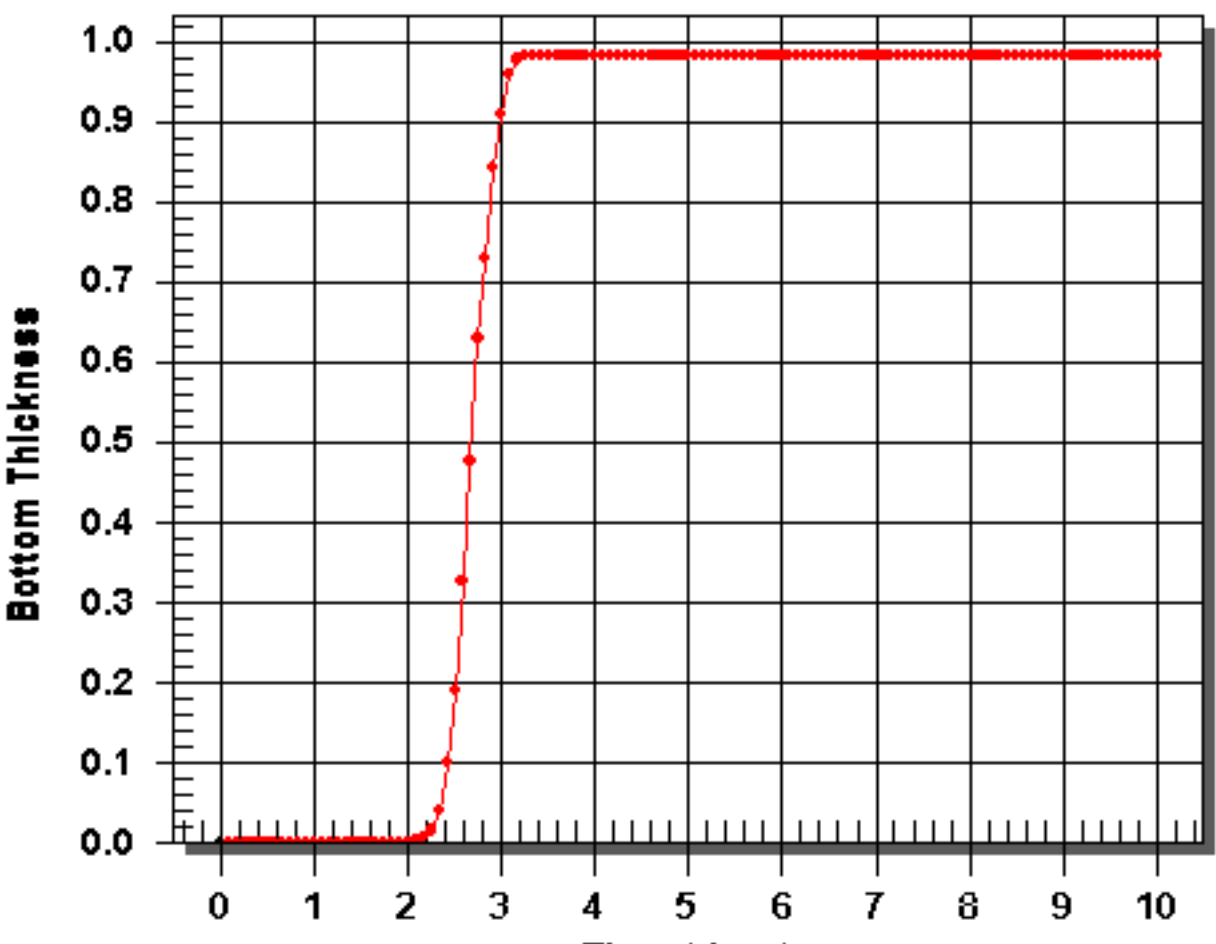

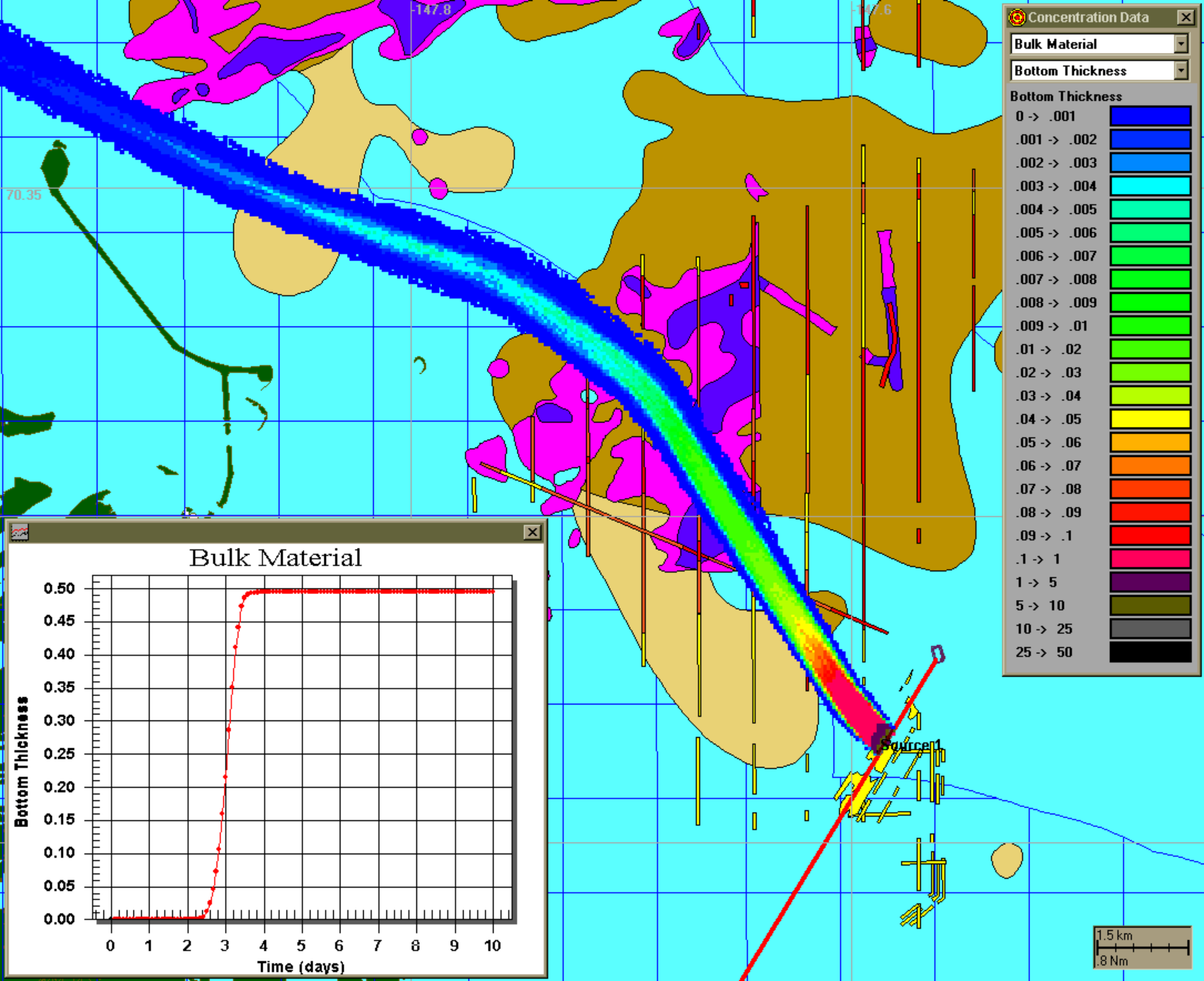

Concentration Data

Bulk Material

Bottom Thickness

Bottom Thickness

0 -> .001	[Dark Blue]
.001 -> .002	[Blue]
.002 -> .003	[Light Blue]
.003 -> .004	[Cyan]
.004 -> .005	[Green-Cyan]
.005 -> .006	[Green]
.006 -> .007	[Light Green]
.007 -> .008	[Green]
.008 -> .009	[Light Green]
.009 -> .01	[Green]
.01 -> .02	[Light Green]
.02 -> .03	[Yellow-Green]
.03 -> .04	[Yellow]
.04 -> .05	[Light Yellow]
.05 -> .06	[Orange]
.06 -> .07	[Red-Orange]
.07 -> .08	[Red]
.08 -> .09	[Dark Red]
.09 -> .1	[Red]
.1 -> 1	[Magenta]
1 -> 5	[Purple]
5 -> 10	[Dark Purple]
10 -> 25	[Black-Gray]
25 -> 50	[Black]

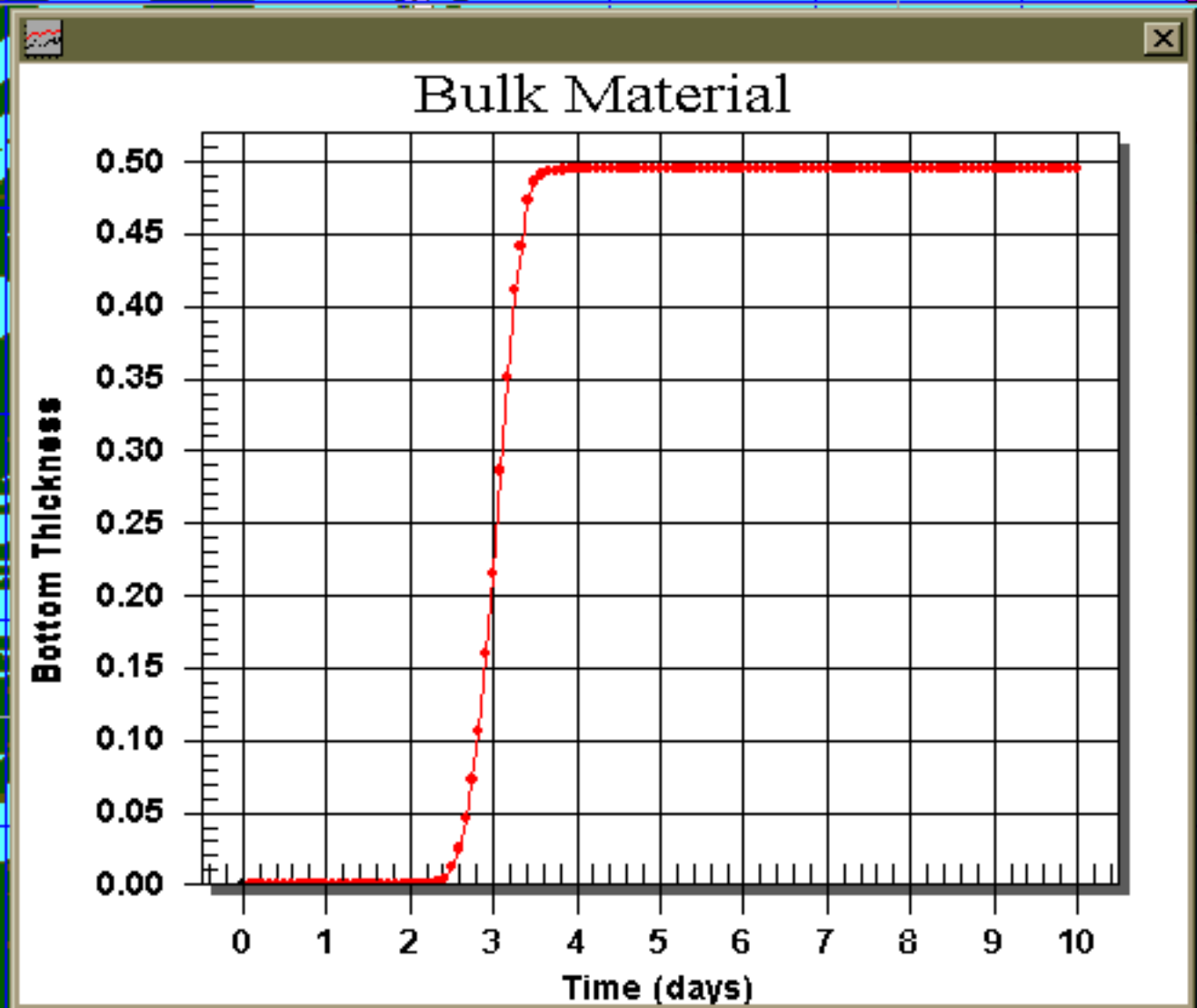

1.5 km
0.8 Nm

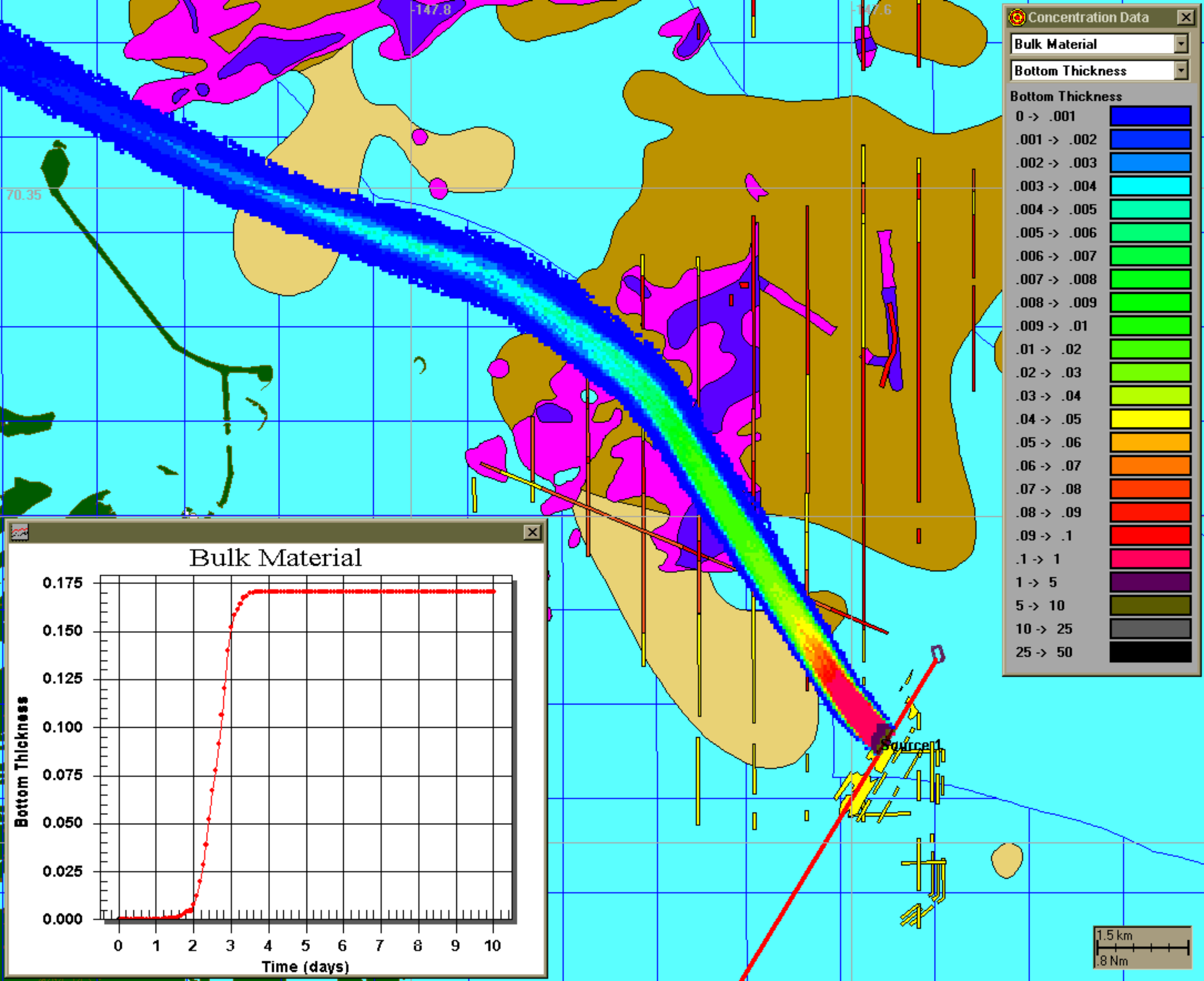

Bulk Material

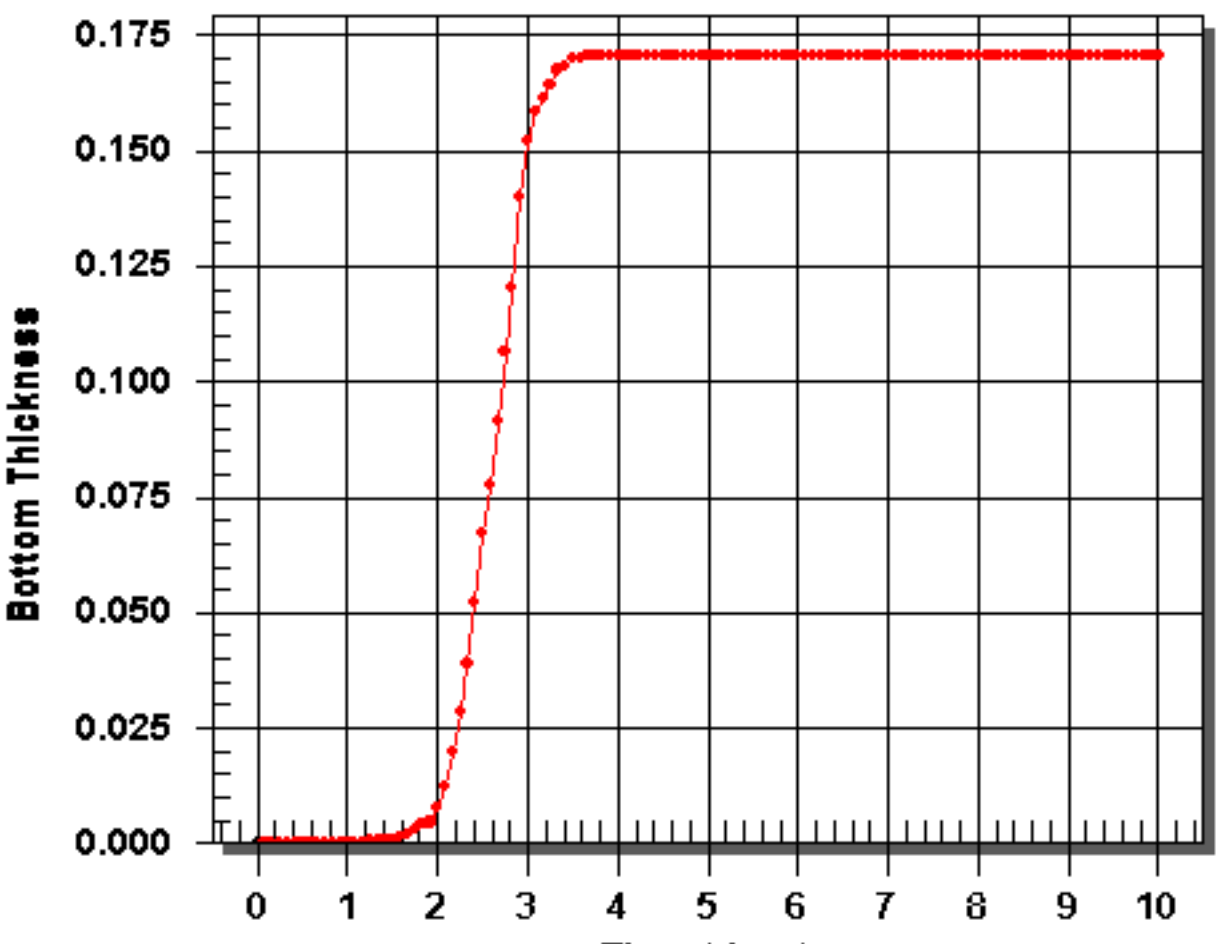

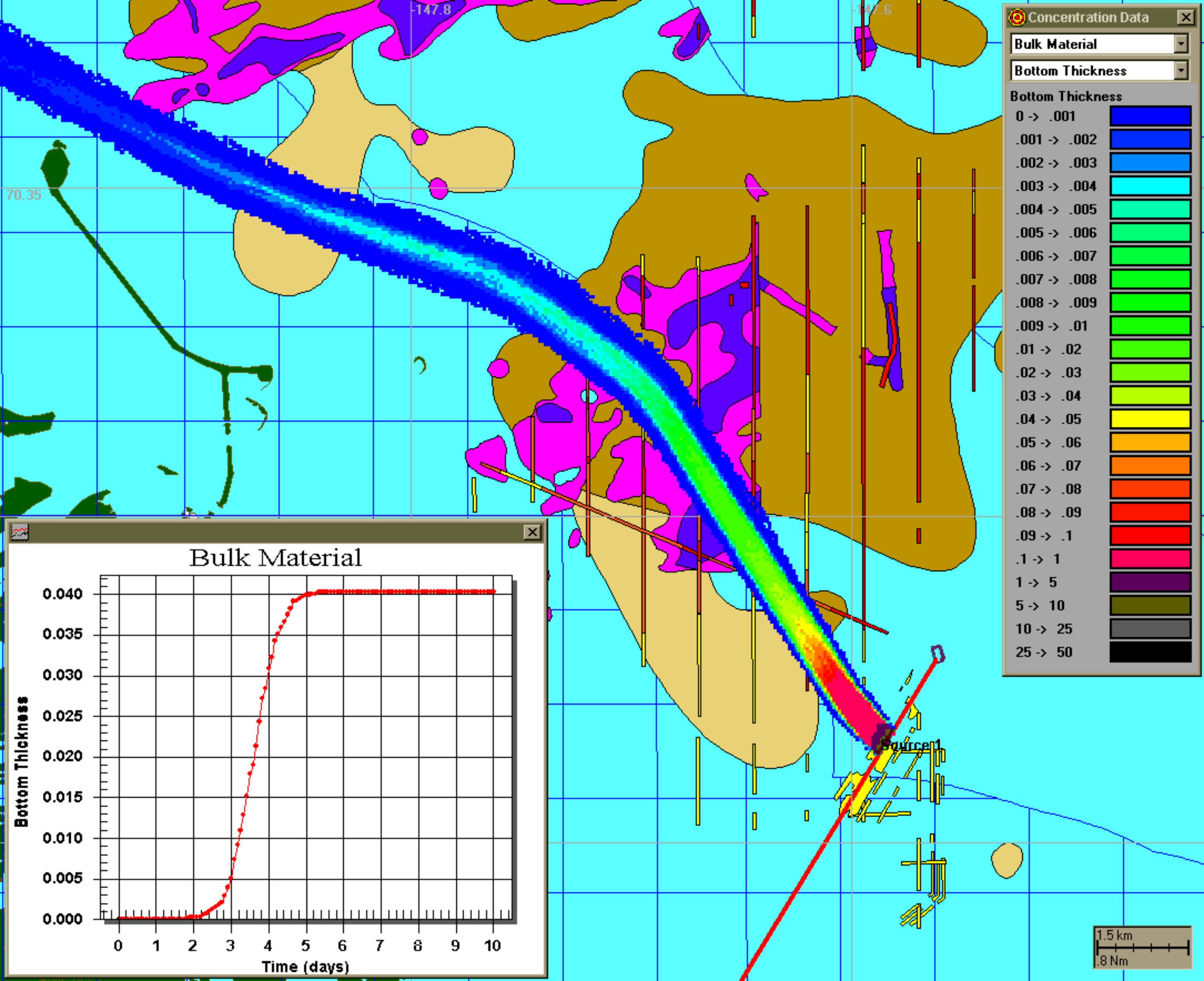

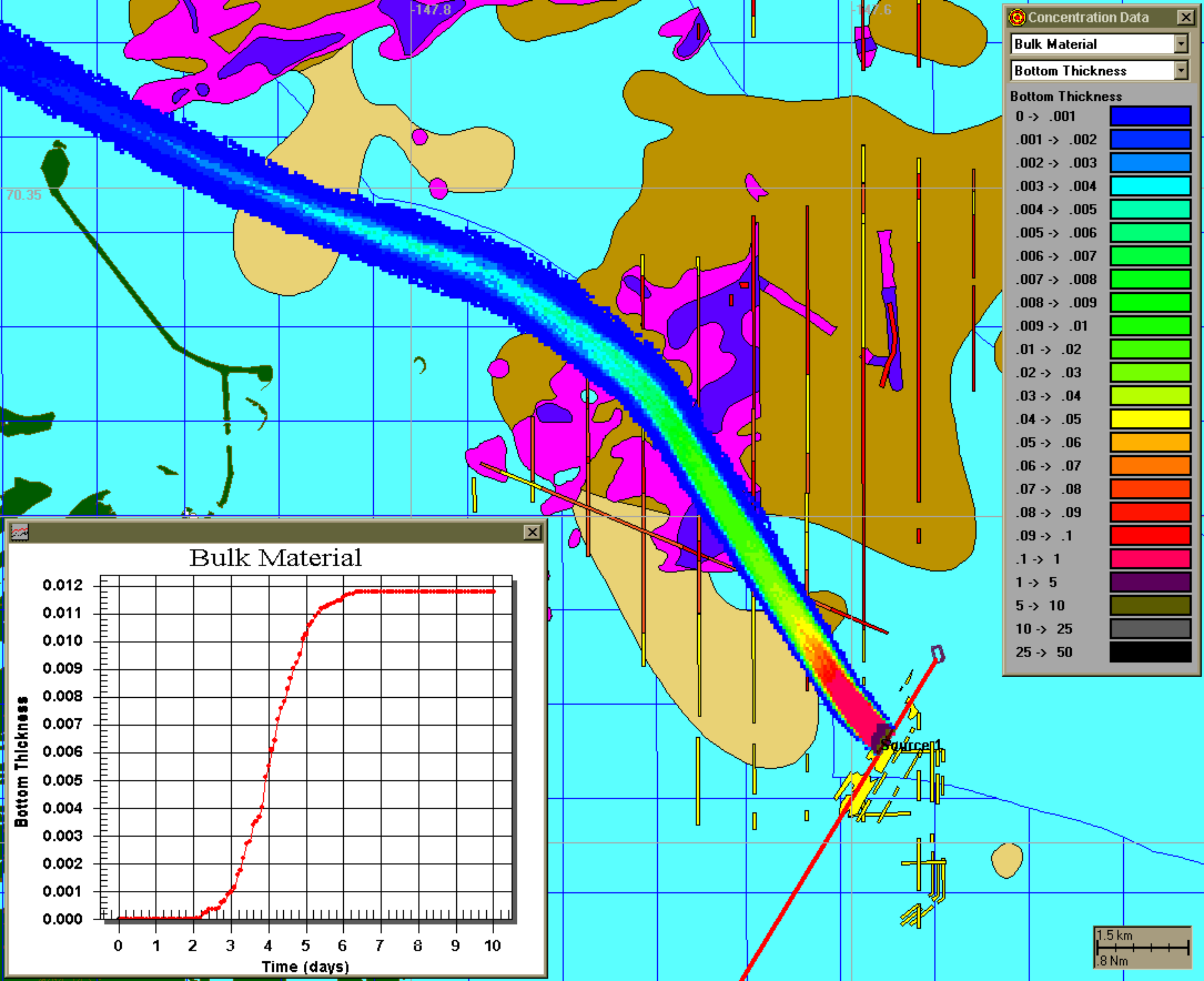

Concentration Data

Bulk Material

Bottom Thickness

Bottom Thickness

0 -> .001	[Blue]
.001 -> .002	[Blue]
.002 -> .003	[Blue]
.003 -> .004	[Cyan]
.004 -> .005	[Cyan]
.005 -> .006	[Green]
.006 -> .007	[Green]
.007 -> .008	[Green]
.008 -> .009	[Green]
.009 -> .01	[Green]
.01 -> .02	[Light Green]
.02 -> .03	[Light Green]
.03 -> .04	[Yellow-Green]
.04 -> .05	[Yellow]
.05 -> .06	[Yellow-Orange]
.06 -> .07	[Orange]
.07 -> .08	[Orange-Red]
.08 -> .09	[Red-Orange]
.09 -> .1	[Red]
.1 -> 1	[Red]
1 -> 5	[Pink]
5 -> 10	[Purple]
10 -> 25	[Dark Purple]
25 -> 50	[Black]

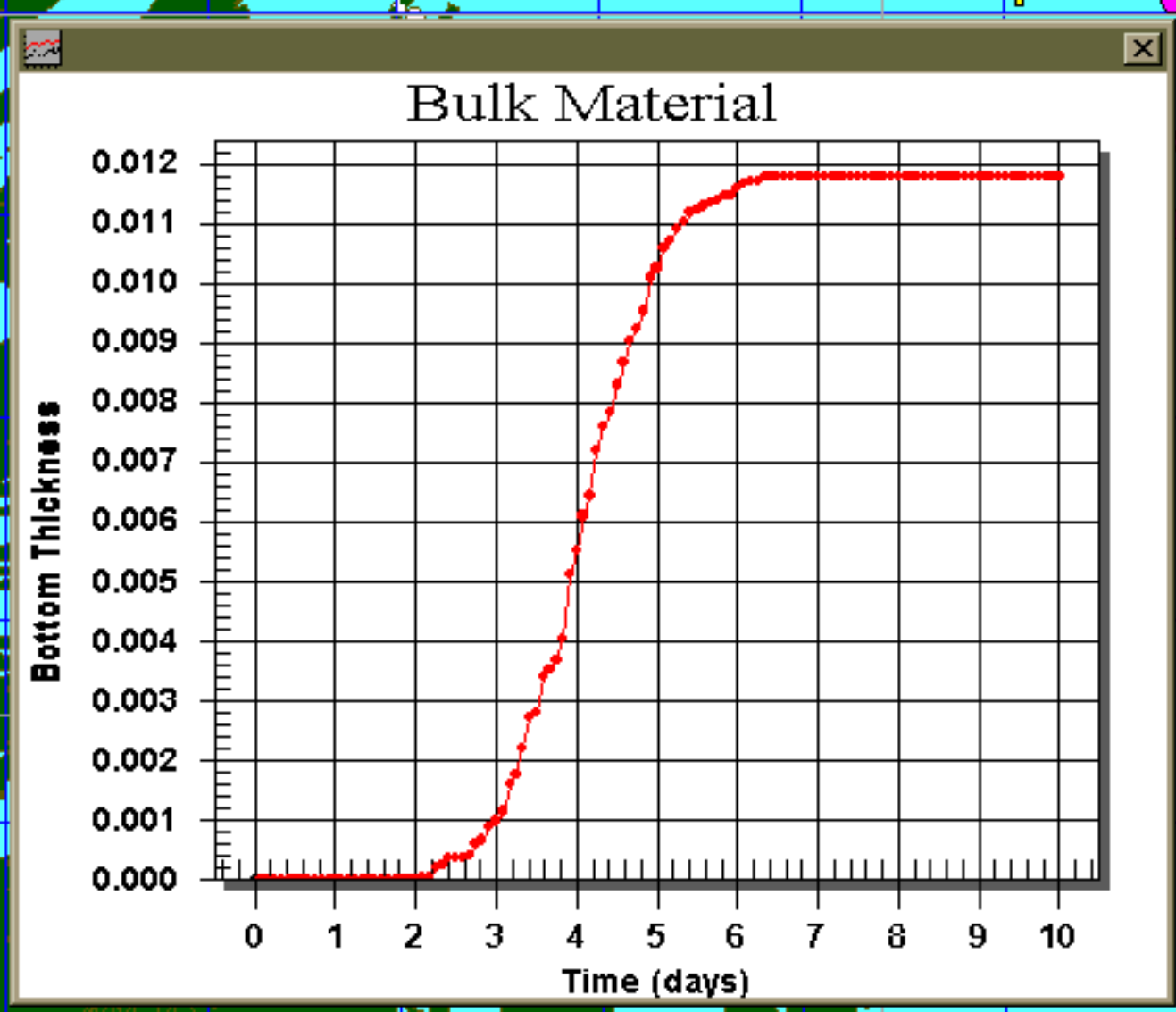

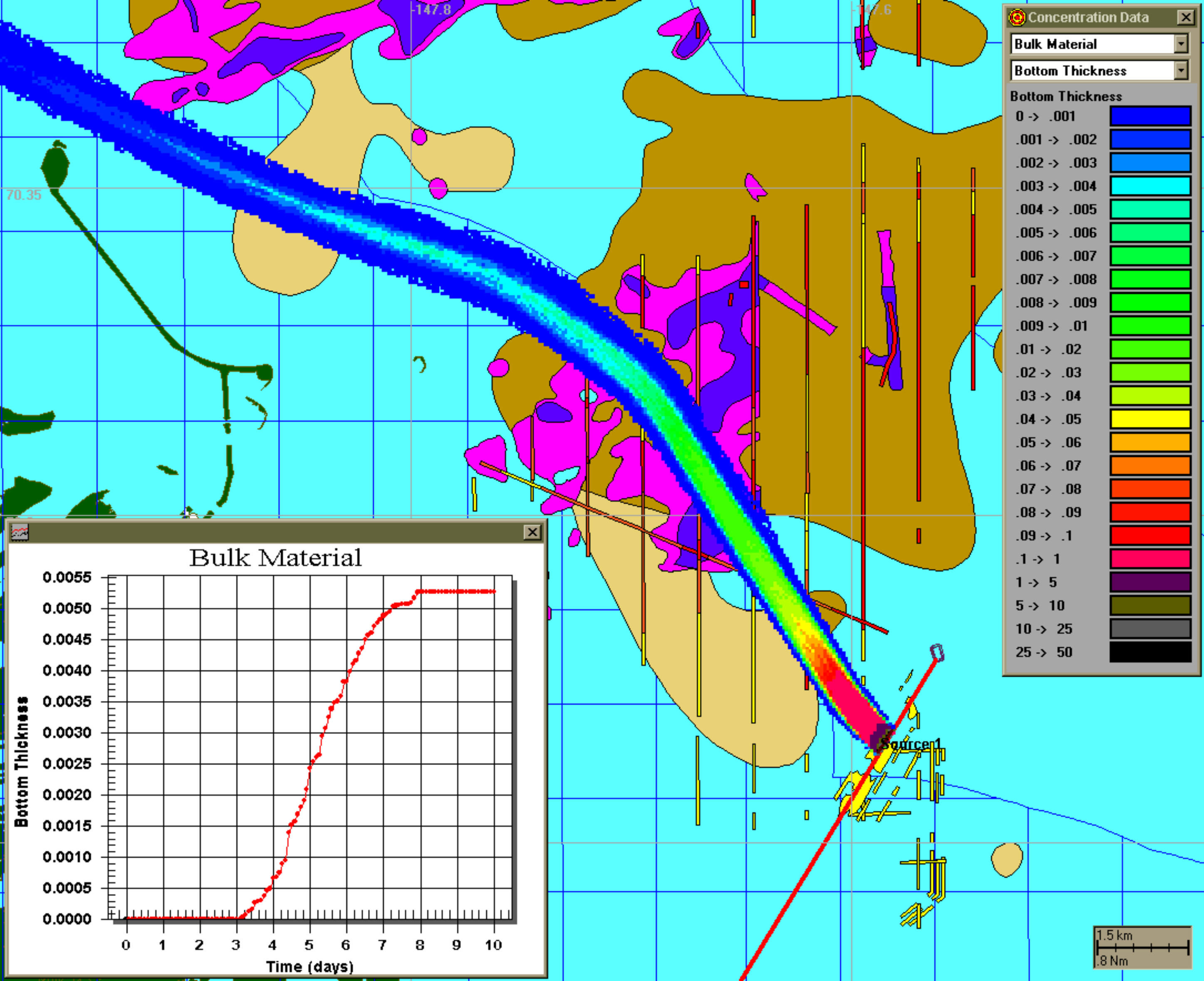

Concentration Data

Bulk Material

Bottom Thickness

Bottom Thickness

0 -> .001	[Blue]
.001 -> .002	[Light Blue]
.002 -> .003	[Cyan]
.003 -> .004	[Light Green]
.004 -> .005	[Green]
.005 -> .006	[Light Green]
.006 -> .007	[Green]
.007 -> .008	[Light Green]
.008 -> .009	[Green]
.009 -> .01	[Light Green]
.01 -> .02	[Light Green]
.02 -> .03	[Light Green]
.03 -> .04	[Light Green]
.04 -> .05	[Yellow]
.05 -> .06	[Orange]
.06 -> .07	[Red-Orange]
.07 -> .08	[Red]
.08 -> .09	[Red]
.09 -> .1	[Red]
.1 -> 1	[Magenta]
1 -> 5	[Purple]
5 -> 10	[Dark Purple]
10 -> 25	[Black]
25 -> 50	[Black]

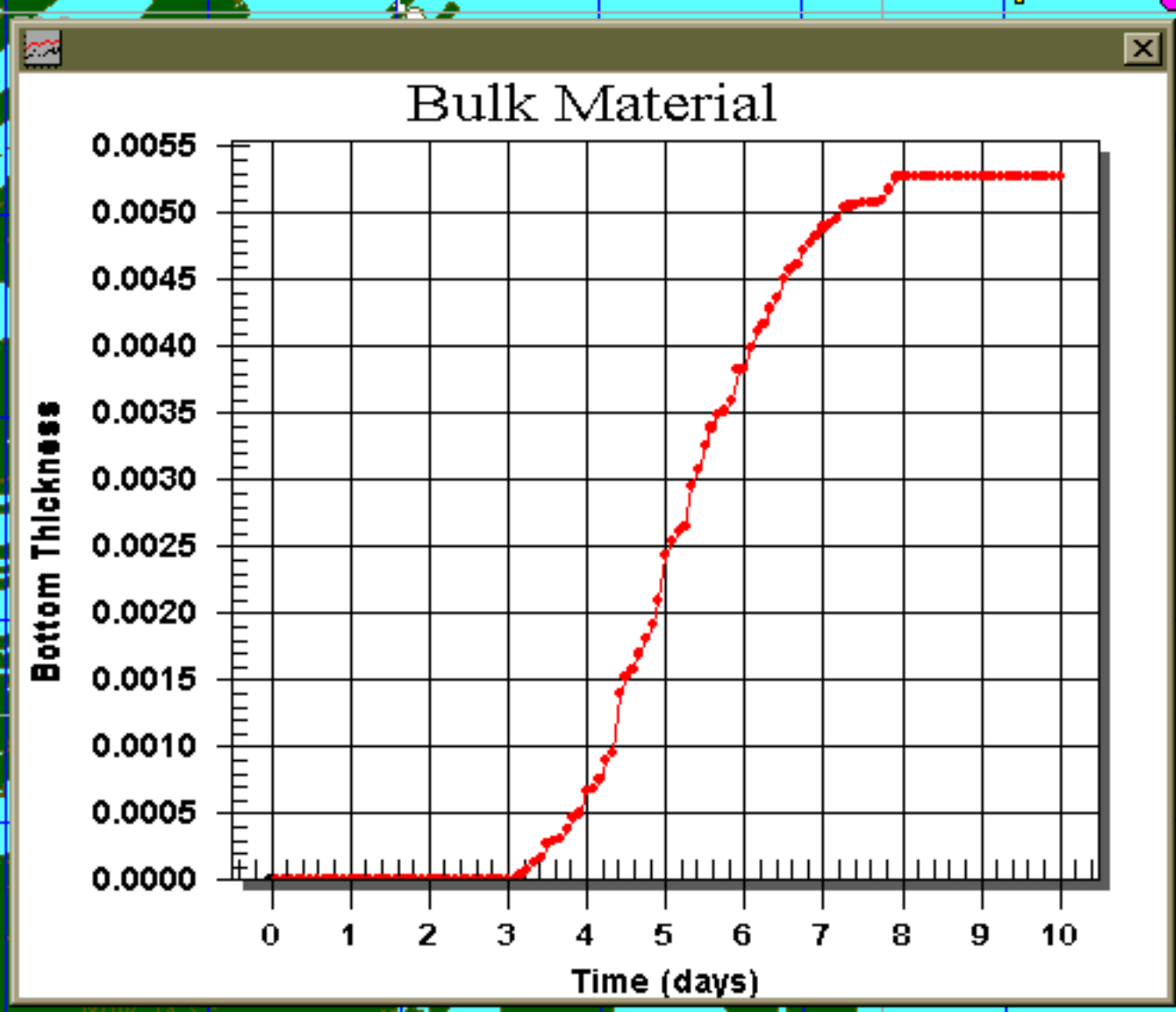

1.5 km
8 Nm

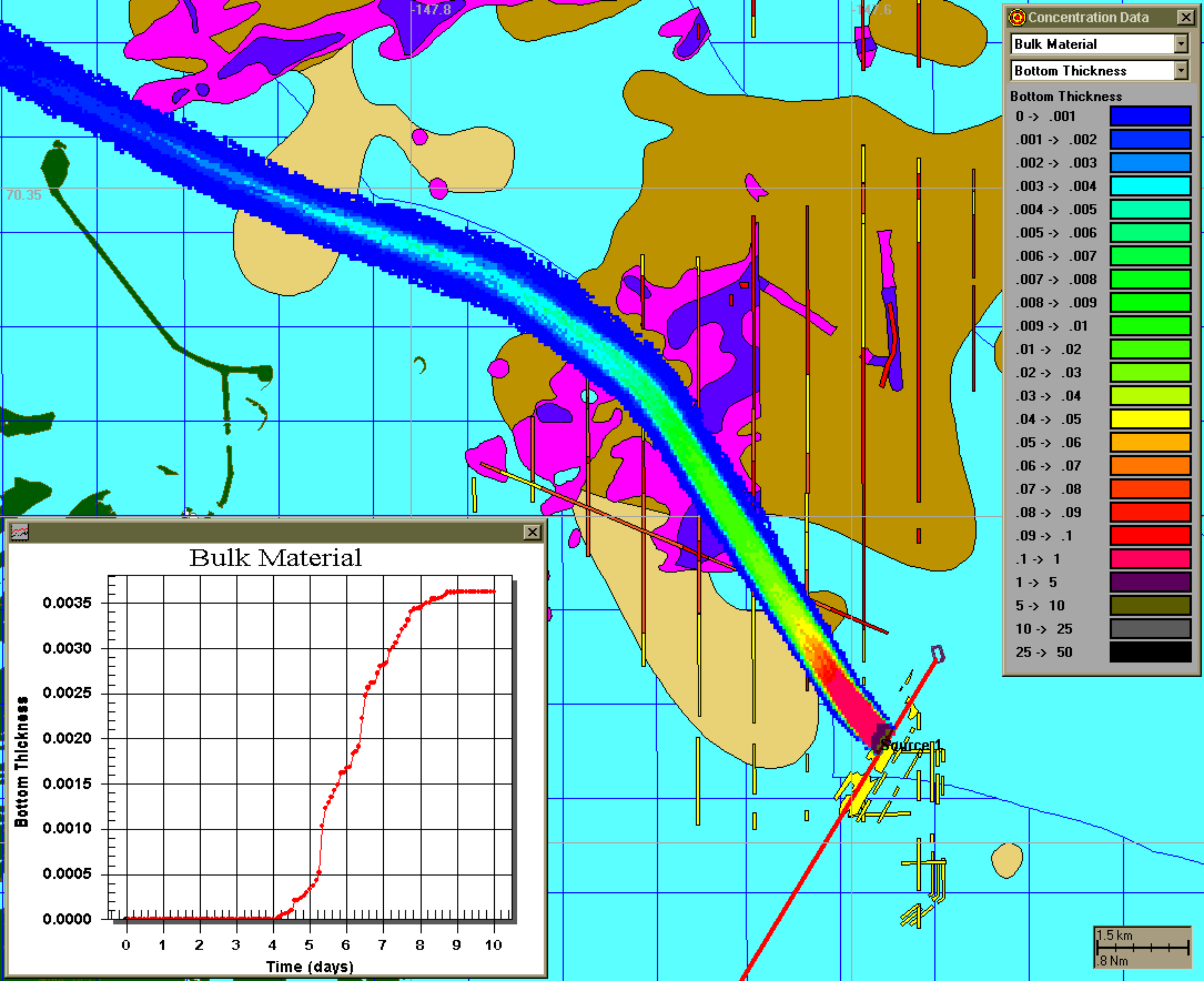

Bulk Material

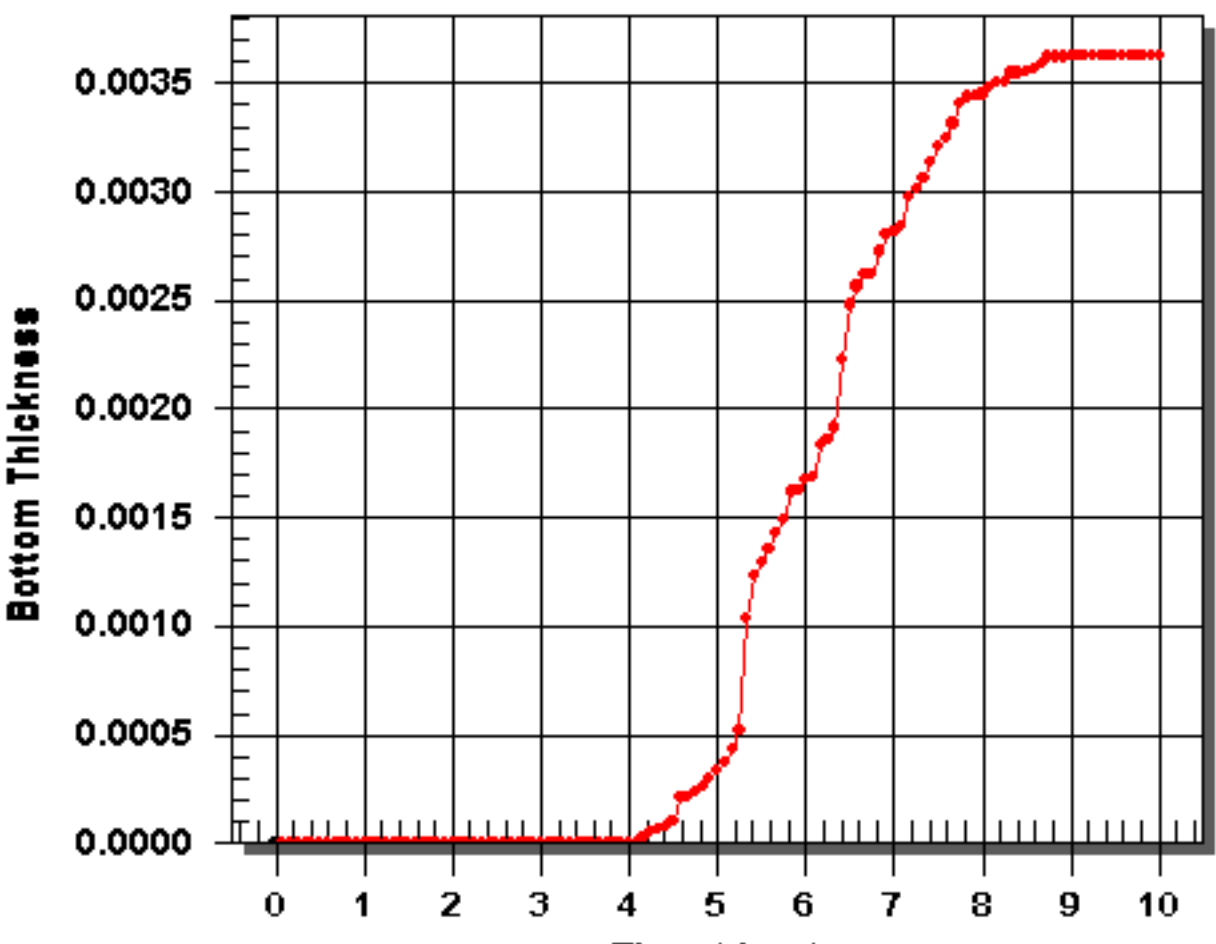

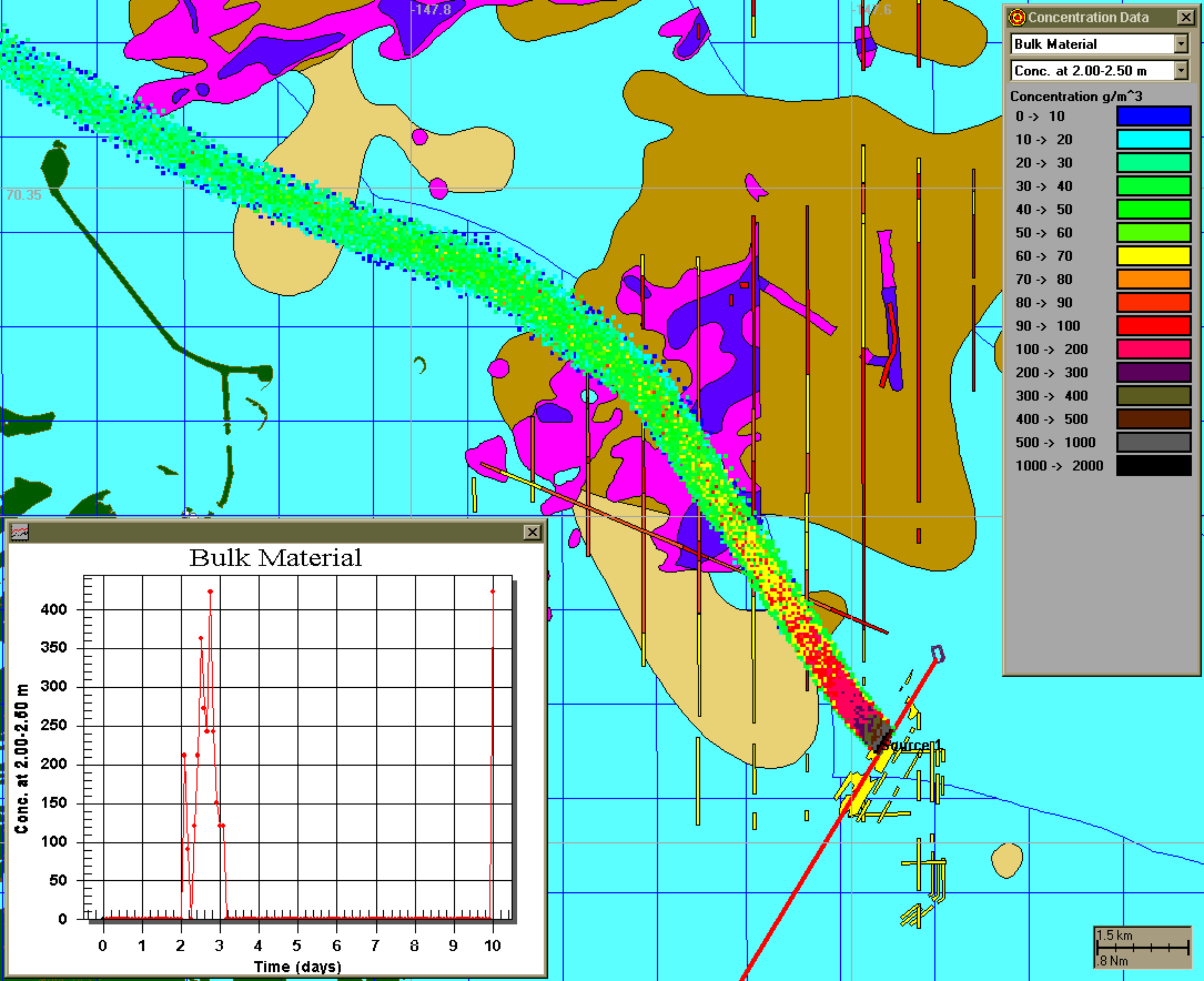

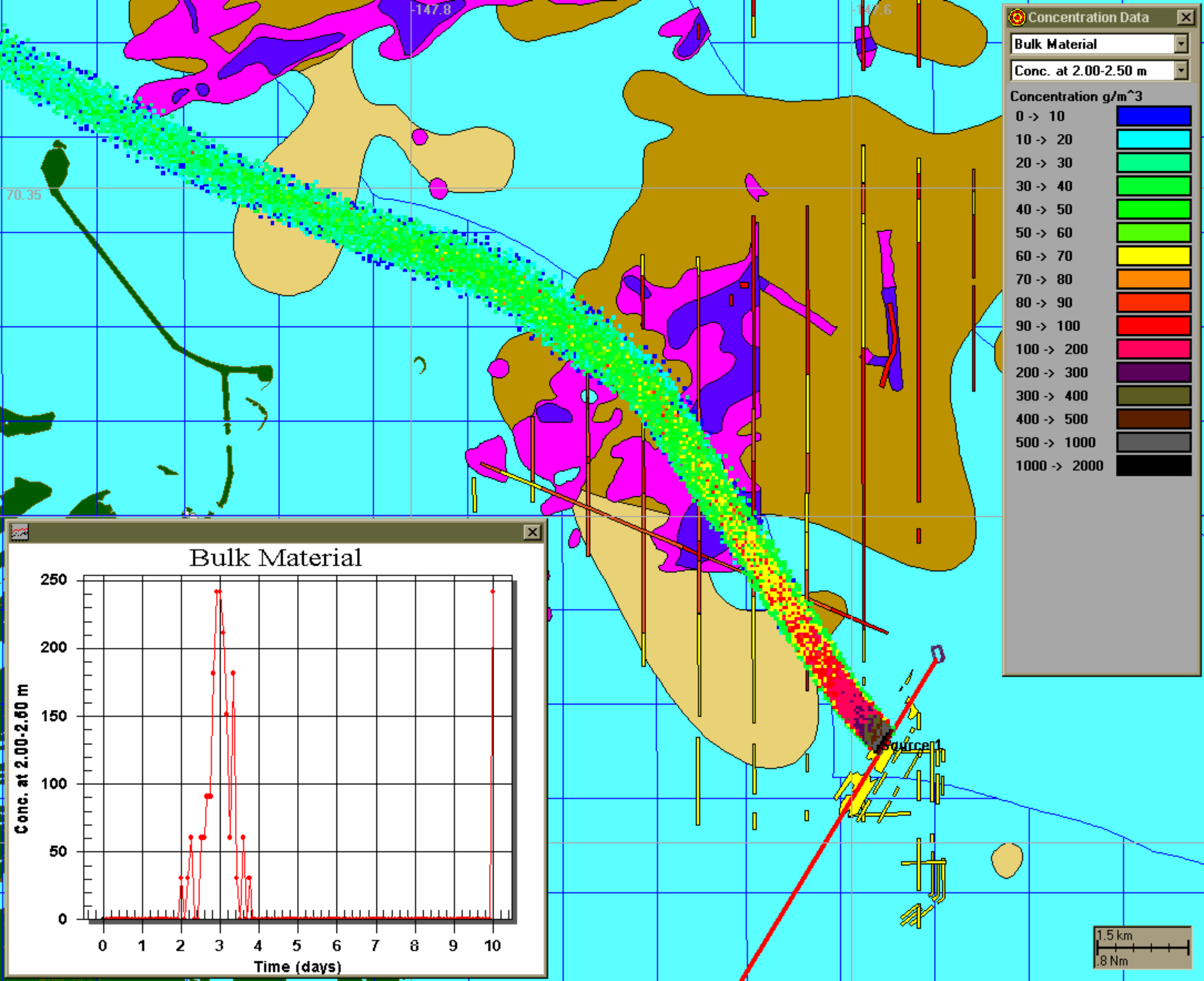

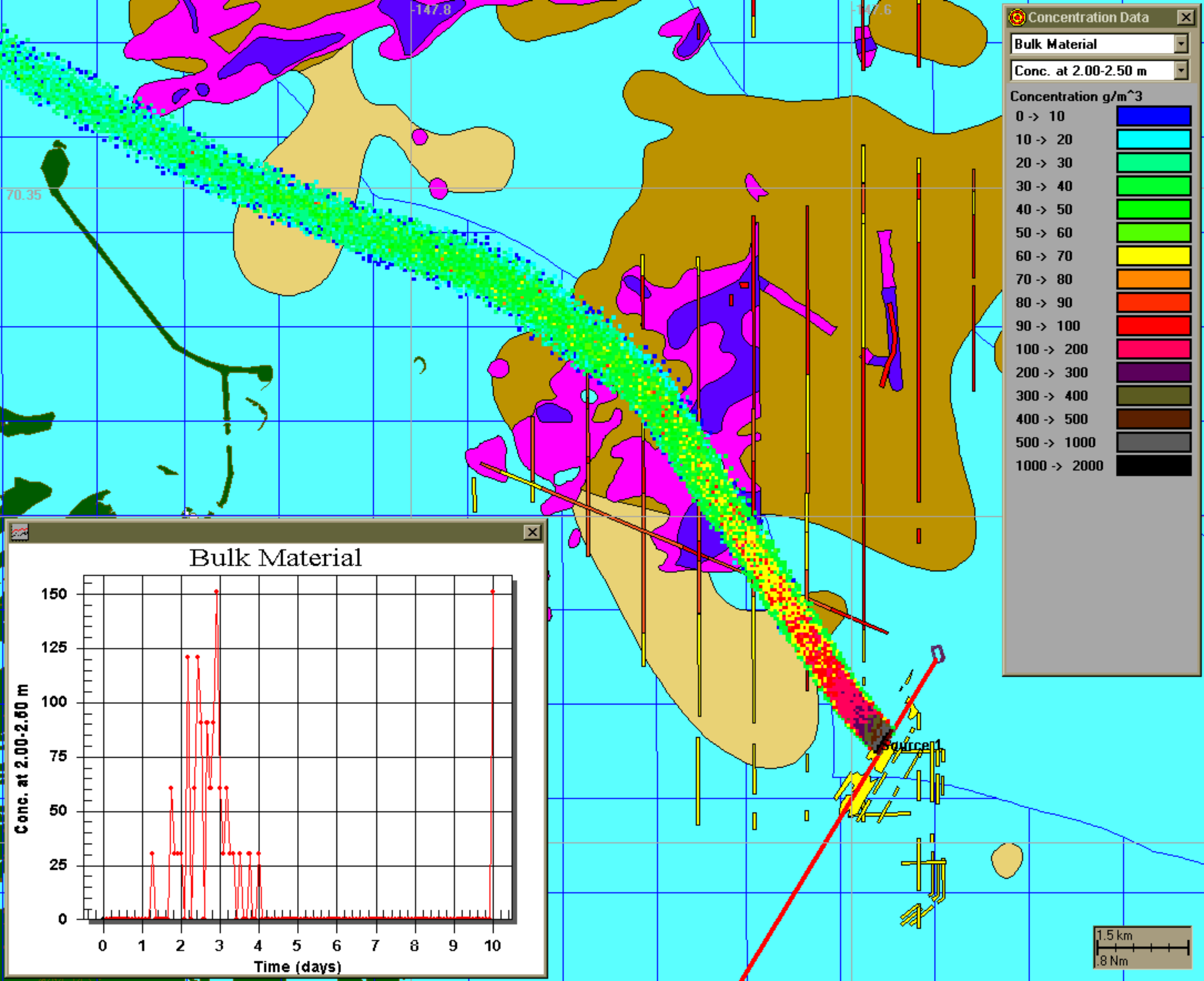

Concentration Data

Bulk Material

Conc. at 2.00-2.50 m

Concentration g/m^3

0 -> 10	Blue
10 -> 20	Cyan
20 -> 30	Light Green
30 -> 40	Green
40 -> 50	Bright Green
50 -> 60	Yellow-Green
60 -> 70	Yellow
70 -> 80	Orange
80 -> 90	Red-Orange
90 -> 100	Red
100 -> 200	Magenta
200 -> 300	Purple
300 -> 400	Olive
400 -> 500	Brown
500 -> 1000	Grey
1000 -> 2000	Black

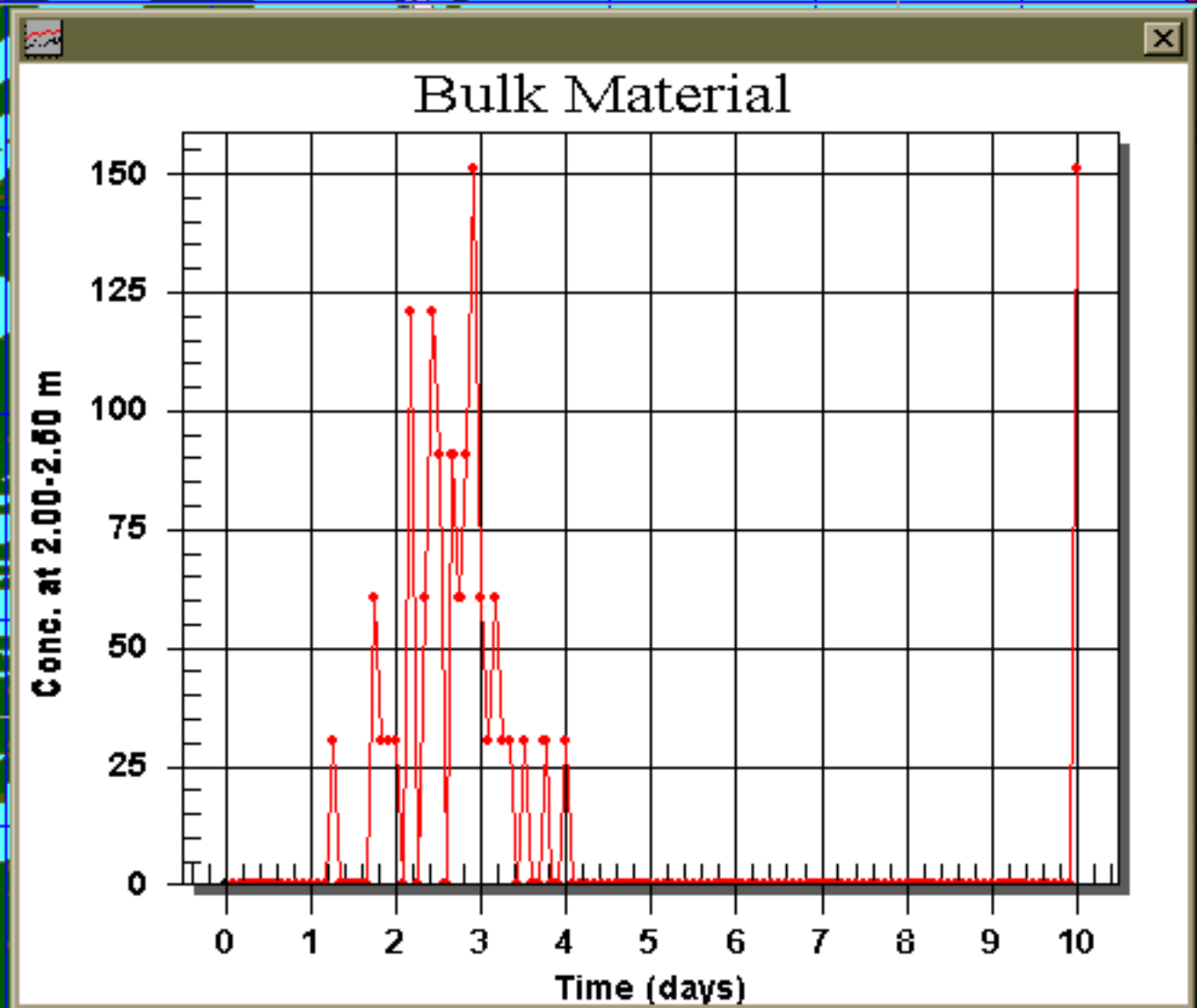

1.5 km
0.8 Nm

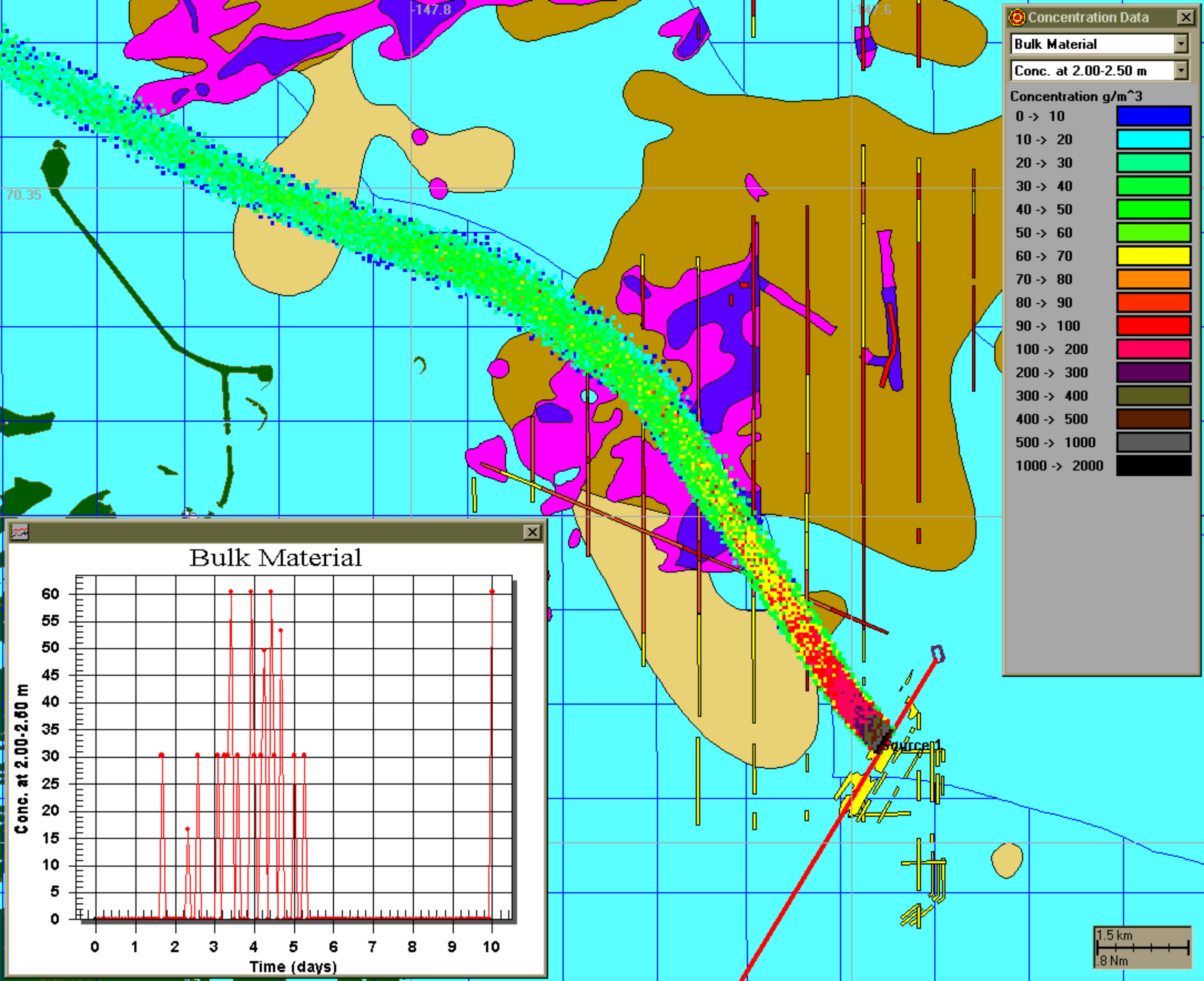

Concentration Data

Bulk Material

Conc. at 2.00-2.50 m

Concentration g/m³

0 -> 10	Blue
10 -> 20	Cyan
20 -> 30	Light Green
30 -> 40	Green
40 -> 50	Yellow-Green
50 -> 60	Yellow
60 -> 70	Orange
70 -> 80	Red-Orange
80 -> 90	Red
90 -> 100	Dark Red
100 -> 200	Magenta
200 -> 300	Purple
300 -> 400	Dark Purple
400 -> 500	Black
500 -> 1000	Dark Grey
1000 -> 2000	Black

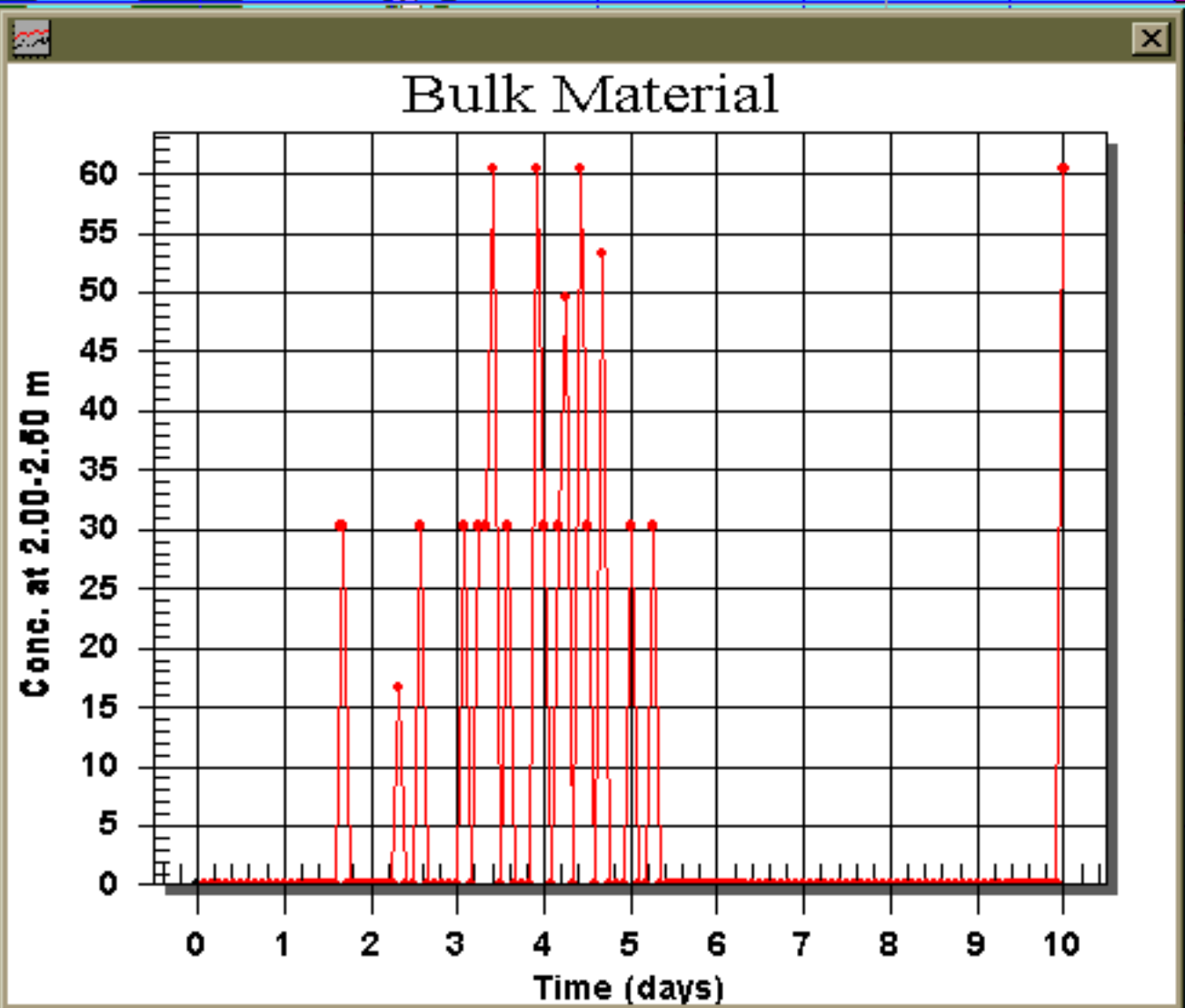

1.5 km
0.8 Nm

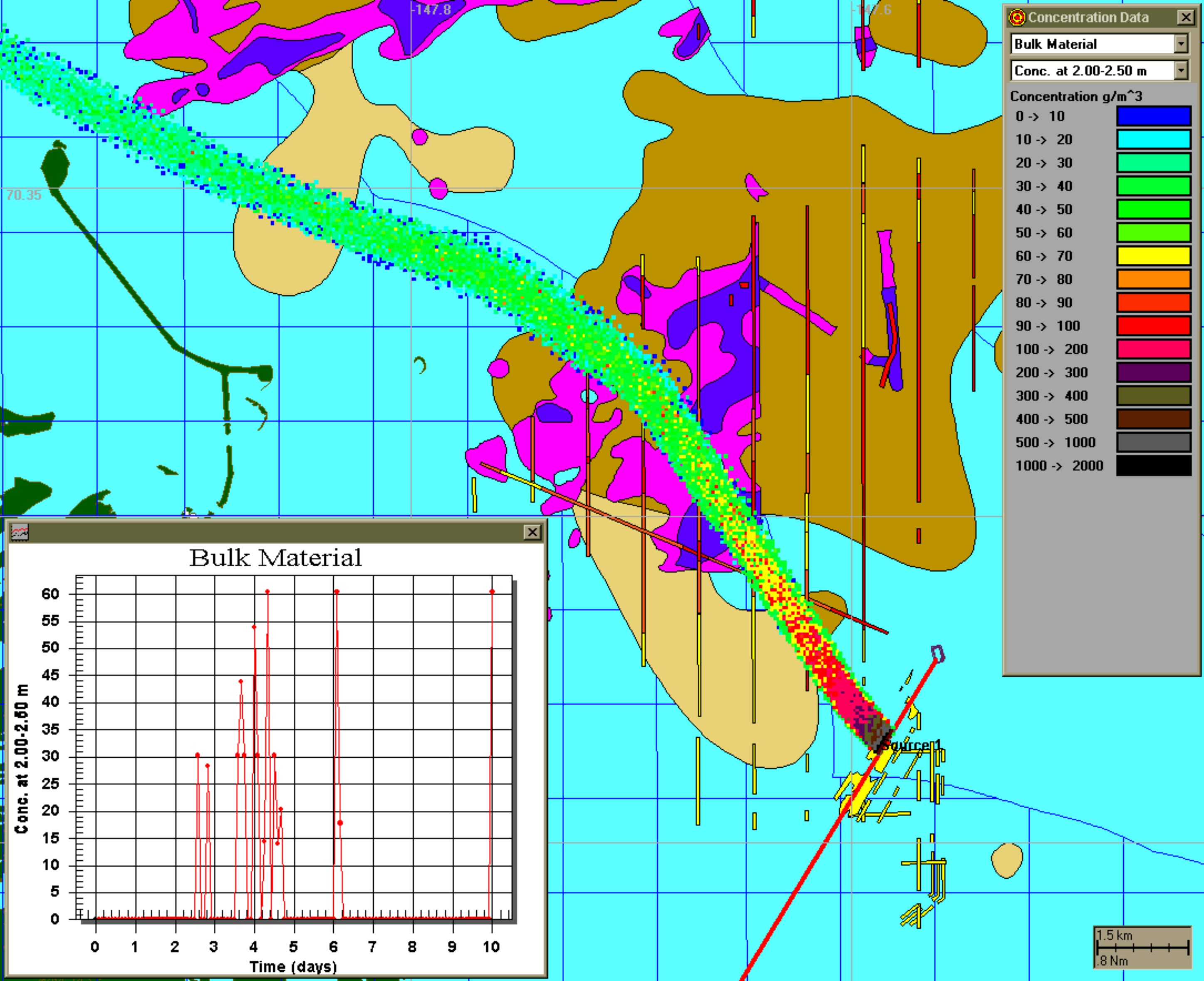

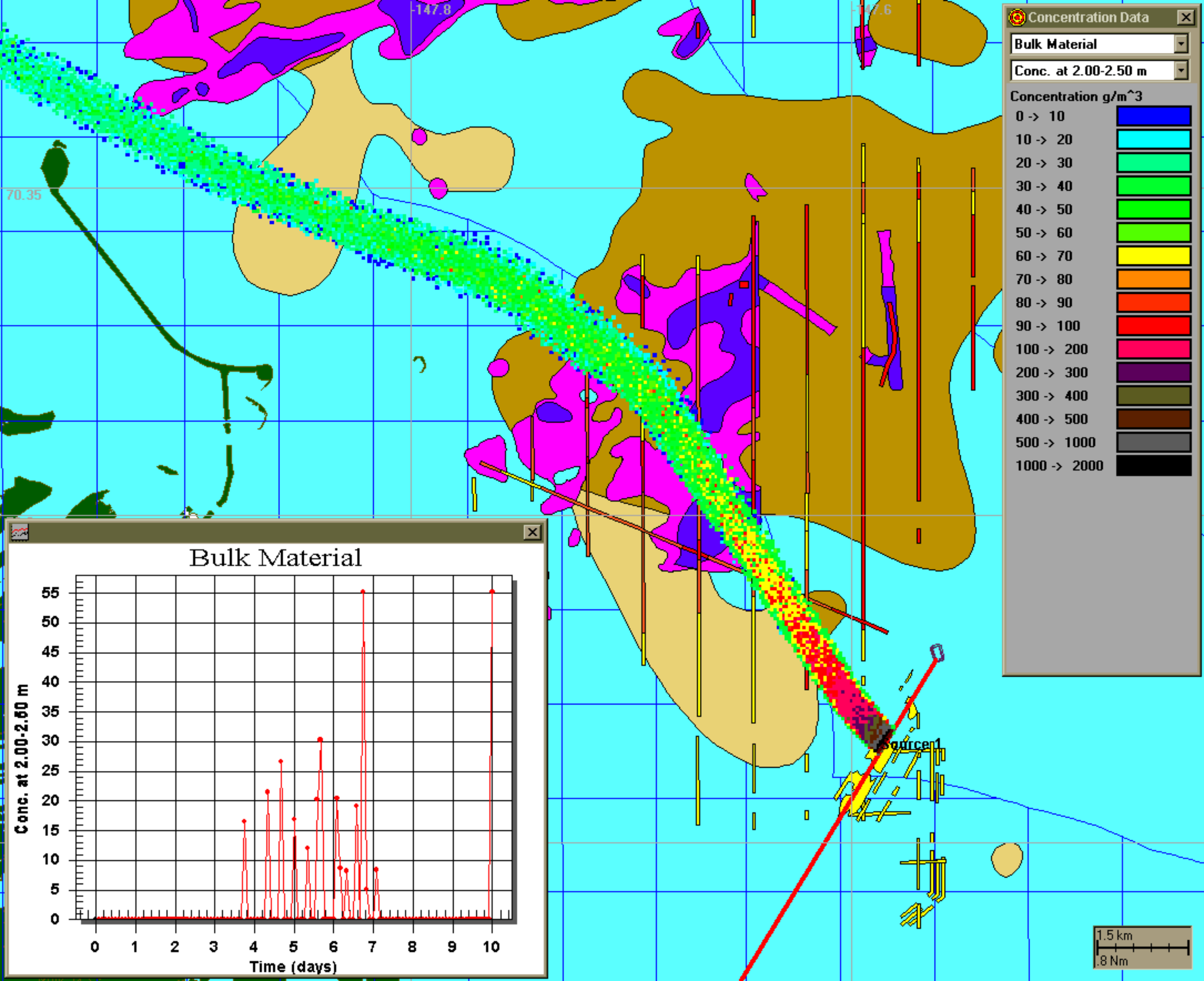

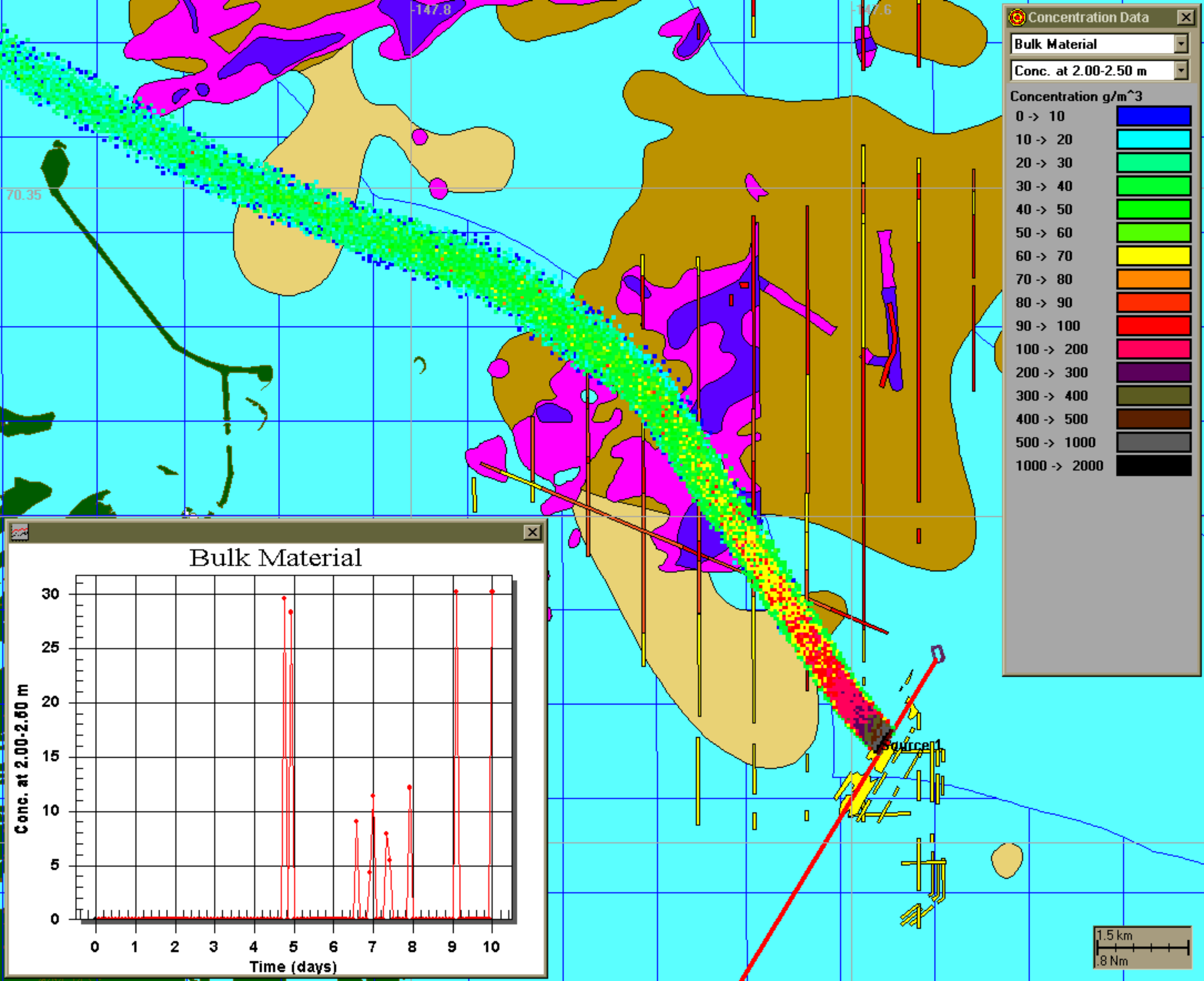

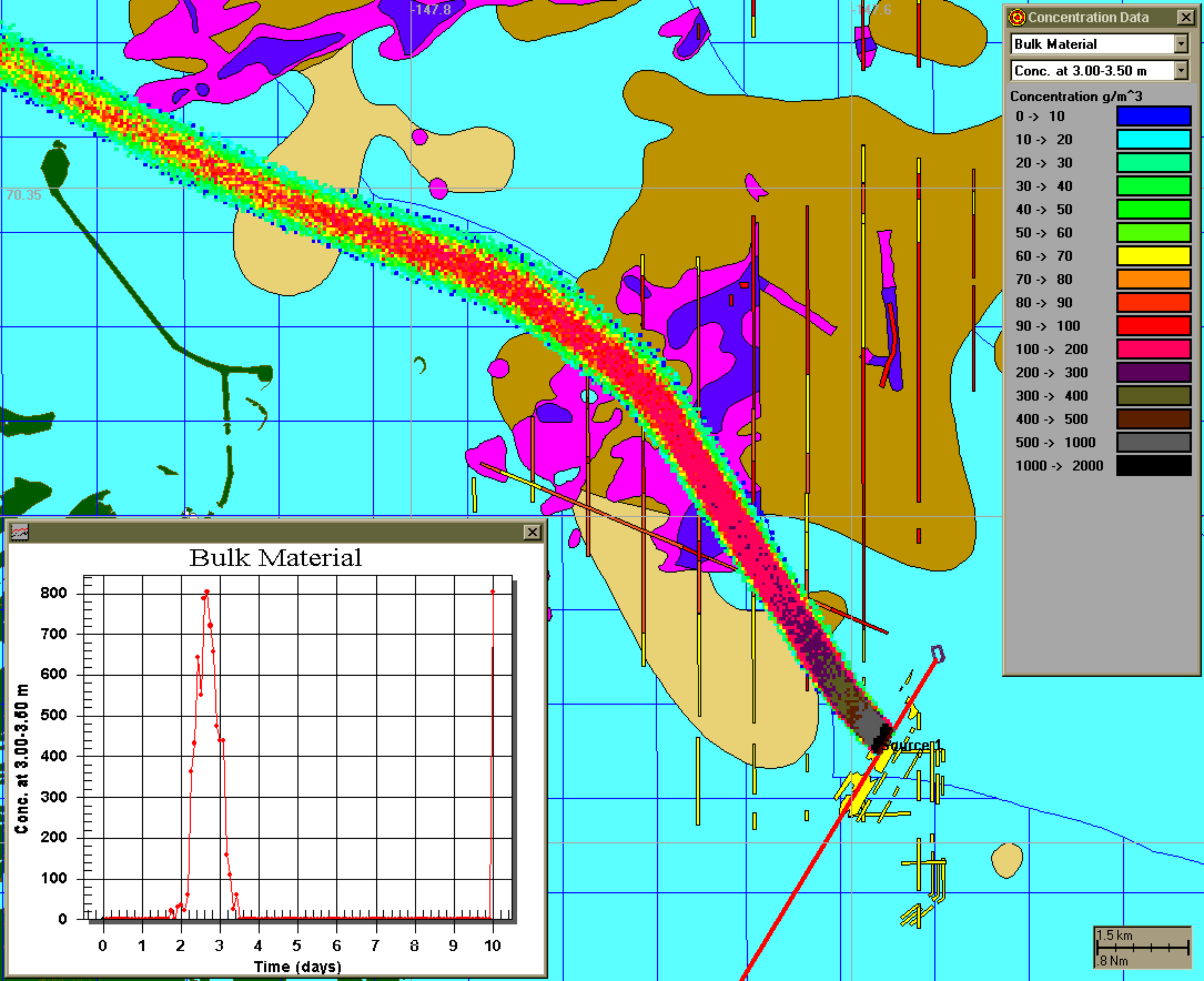

Concentration Data

Bulk Material

Conc. at 3.00-3.50 m

Concentration g/m^3

0 -> 10	Blue
10 -> 20	Cyan
20 -> 30	Light Green
30 -> 40	Green
40 -> 50	Bright Green
50 -> 60	Yellow-Green
60 -> 70	Yellow
70 -> 80	Orange
80 -> 90	Red-Orange
90 -> 100	Red
100 -> 200	Magenta
200 -> 300	Dark Purple
300 -> 400	Olive Green
400 -> 500	Brown
500 -> 1000	Grey
1000 -> 2000	Black

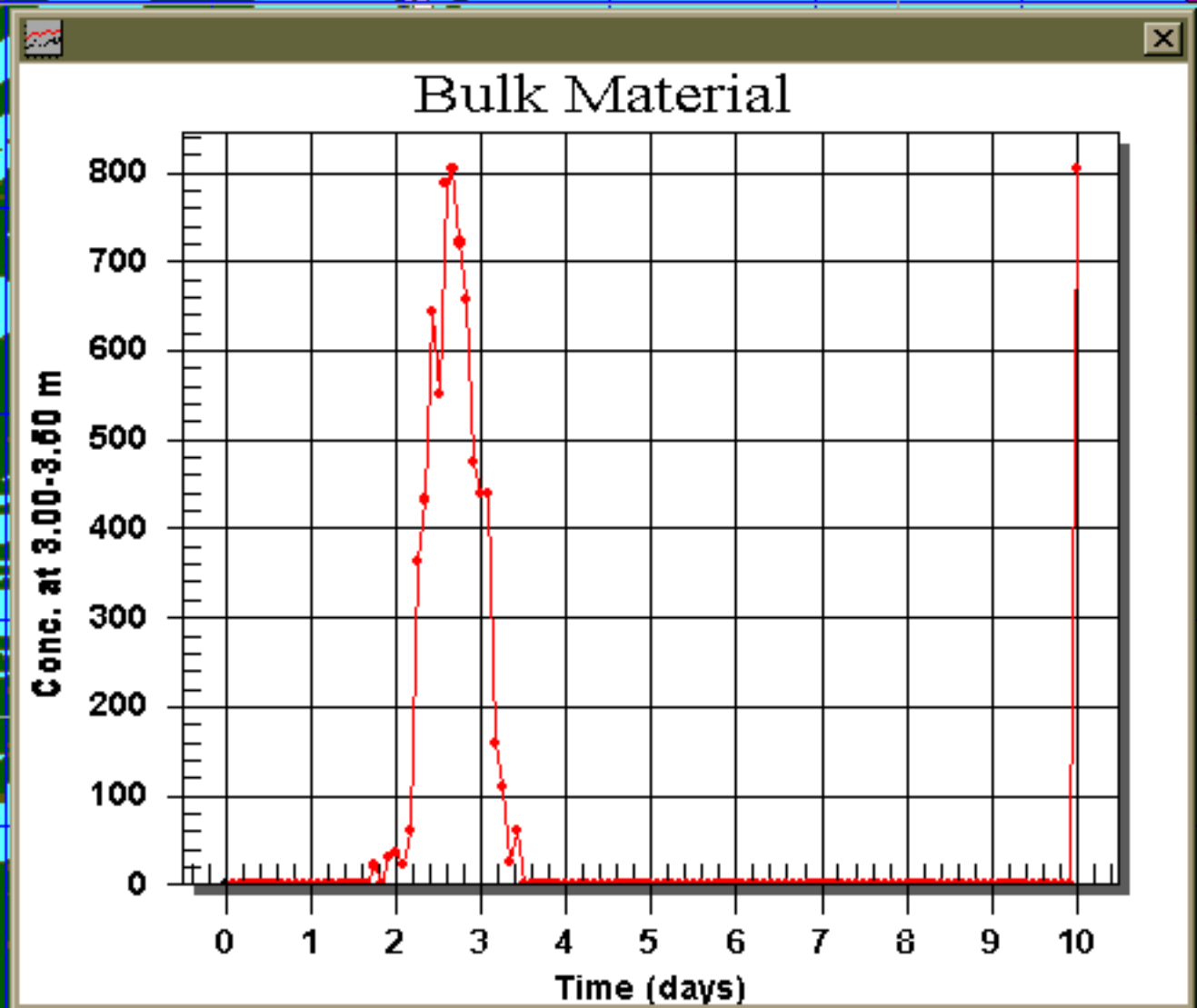

1.5 km
0.8 Nm

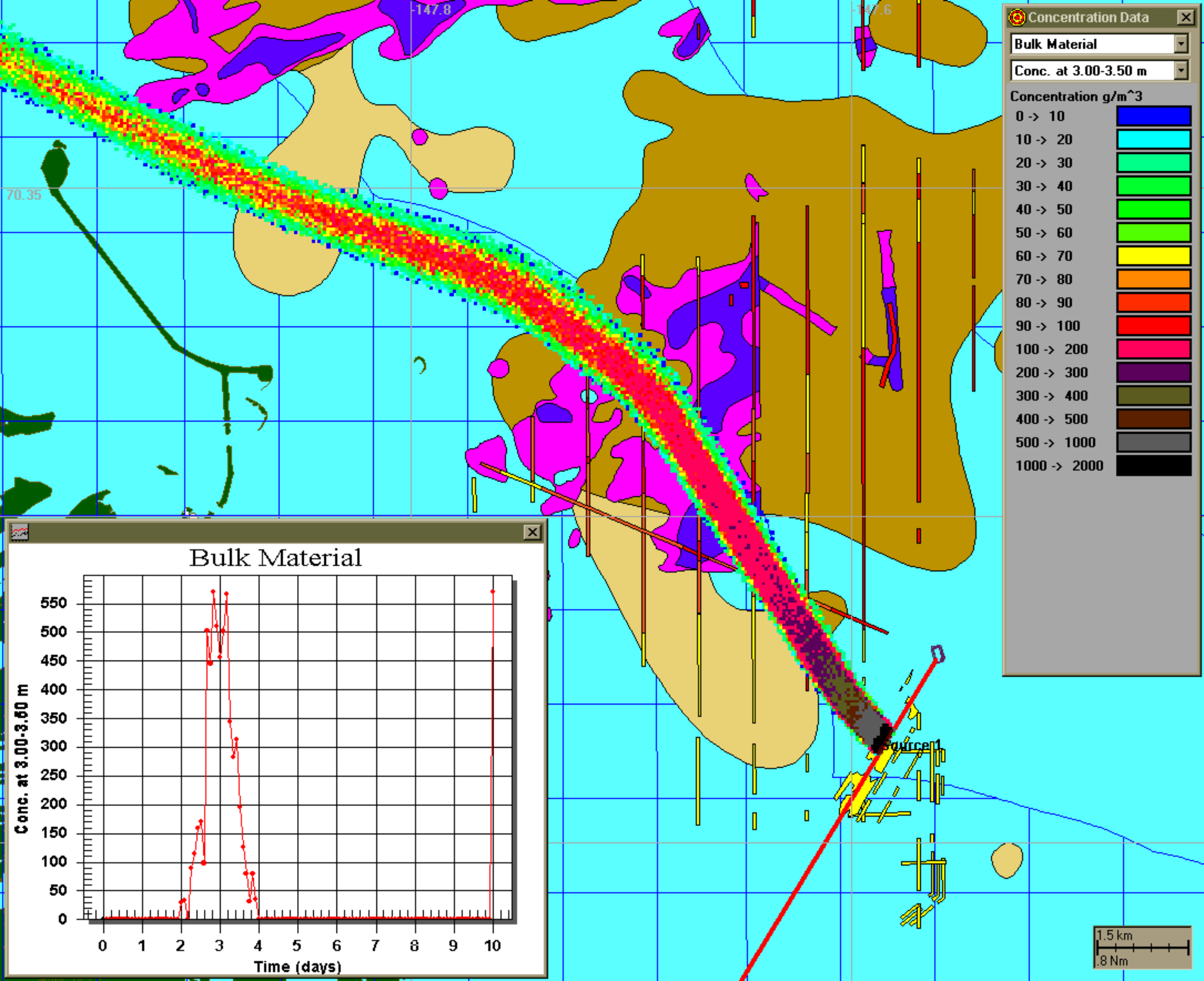

Concentration Data

Bulk Material

Conc. at 3.00-3.50 m

Concentration g/m^3

0 -> 10	Blue
10 -> 20	Cyan
20 -> 30	Light Green
30 -> 40	Green
40 -> 50	Yellow-Green
50 -> 60	Yellow
60 -> 70	Orange
70 -> 80	Red-Orange
80 -> 90	Red
90 -> 100	Dark Red
100 -> 200	Magenta
200 -> 300	Purple
300 -> 400	Dark Purple
400 -> 500	Black
500 -> 1000	Grey
1000 -> 2000	Dark Grey

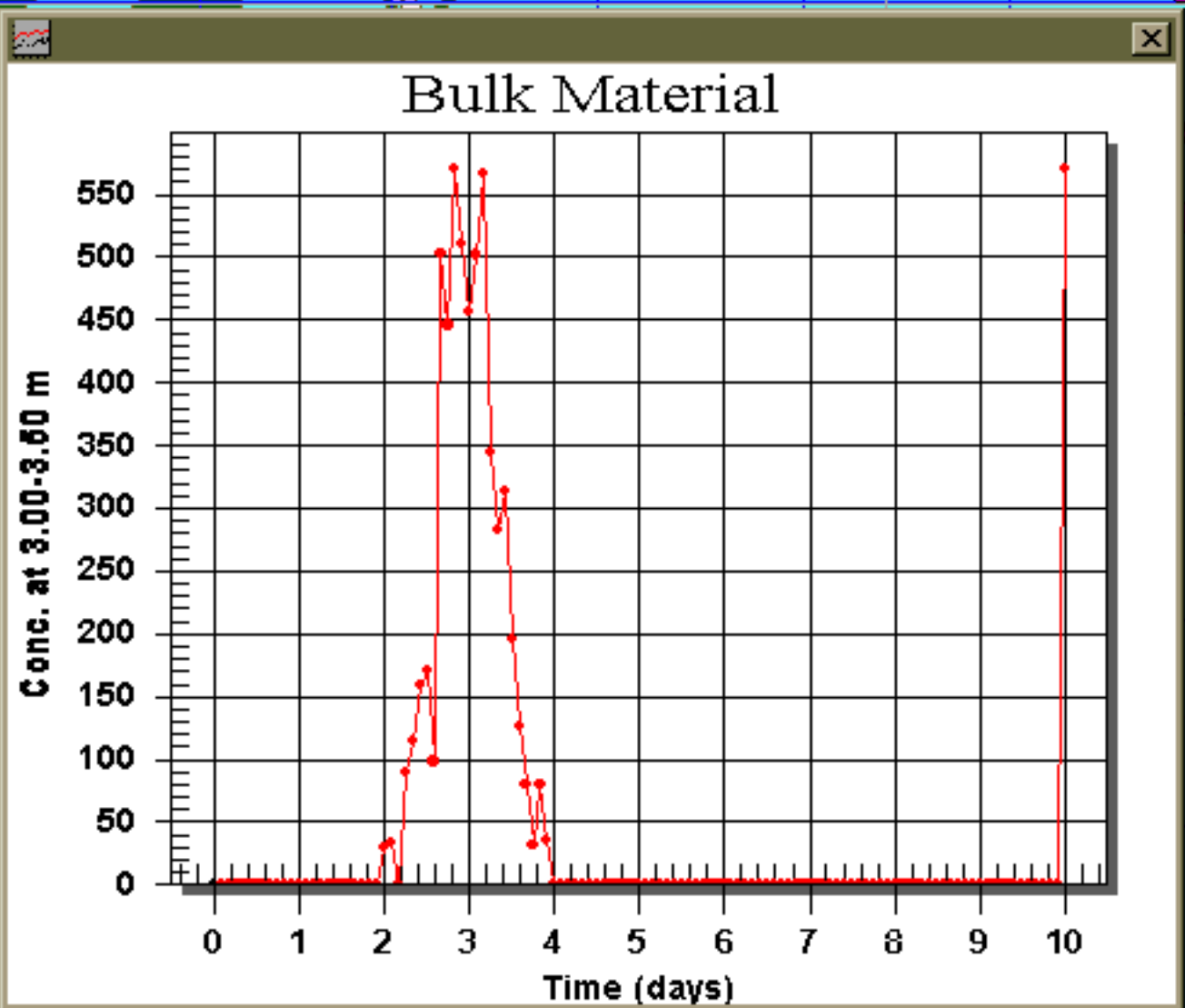

1.5 km
0.8 Nm

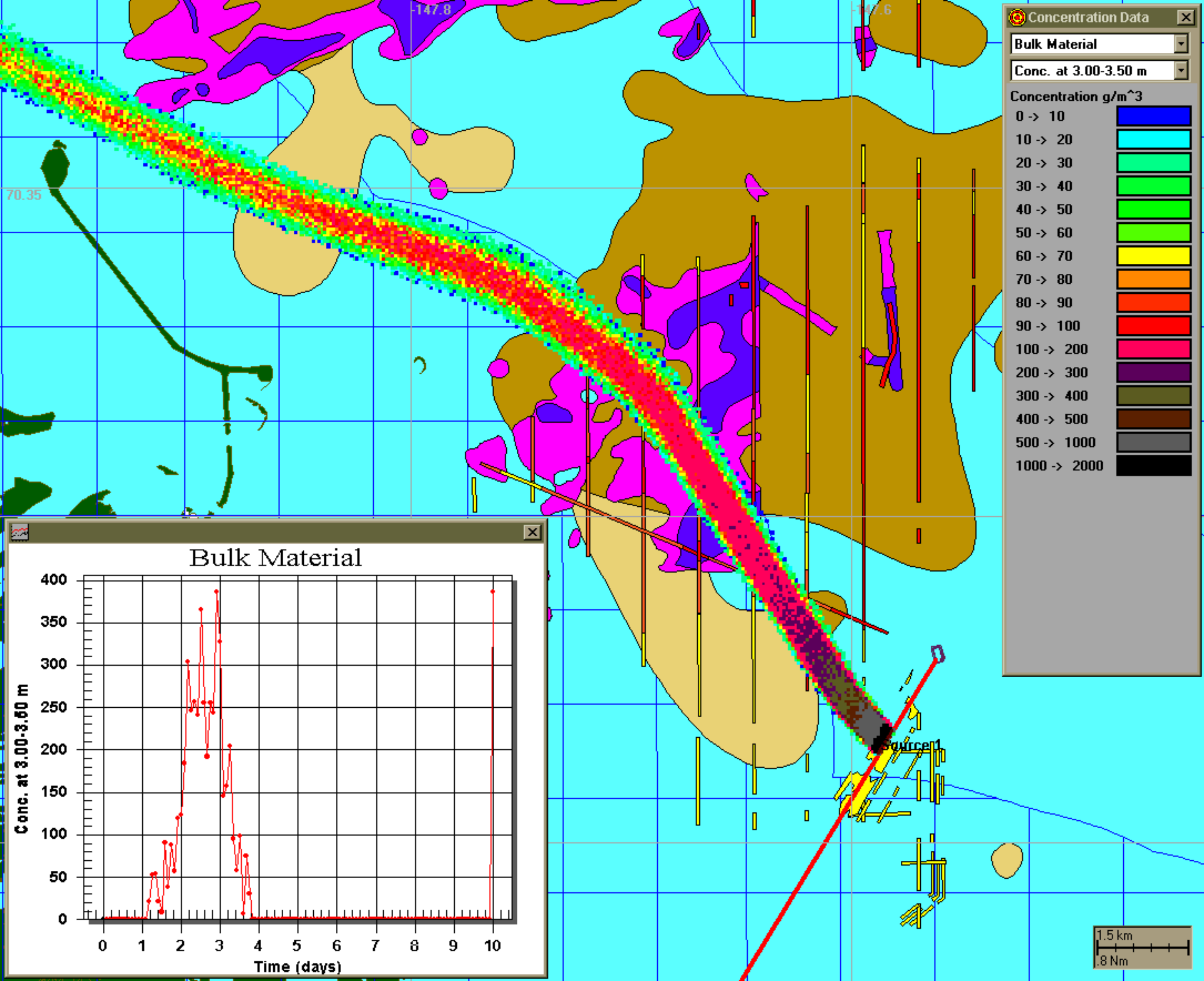

Concentration Data

Bulk Material

Conc. at 3.00-3.50 m

Concentration g/m³

- 0 -> 10
- 10 -> 20
- 20 -> 30
- 30 -> 40
- 40 -> 50
- 50 -> 60
- 60 -> 70
- 70 -> 80
- 80 -> 90
- 90 -> 100
- 100 -> 200
- 200 -> 300
- 300 -> 400
- 400 -> 500
- 500 -> 1000
- 1000 -> 2000

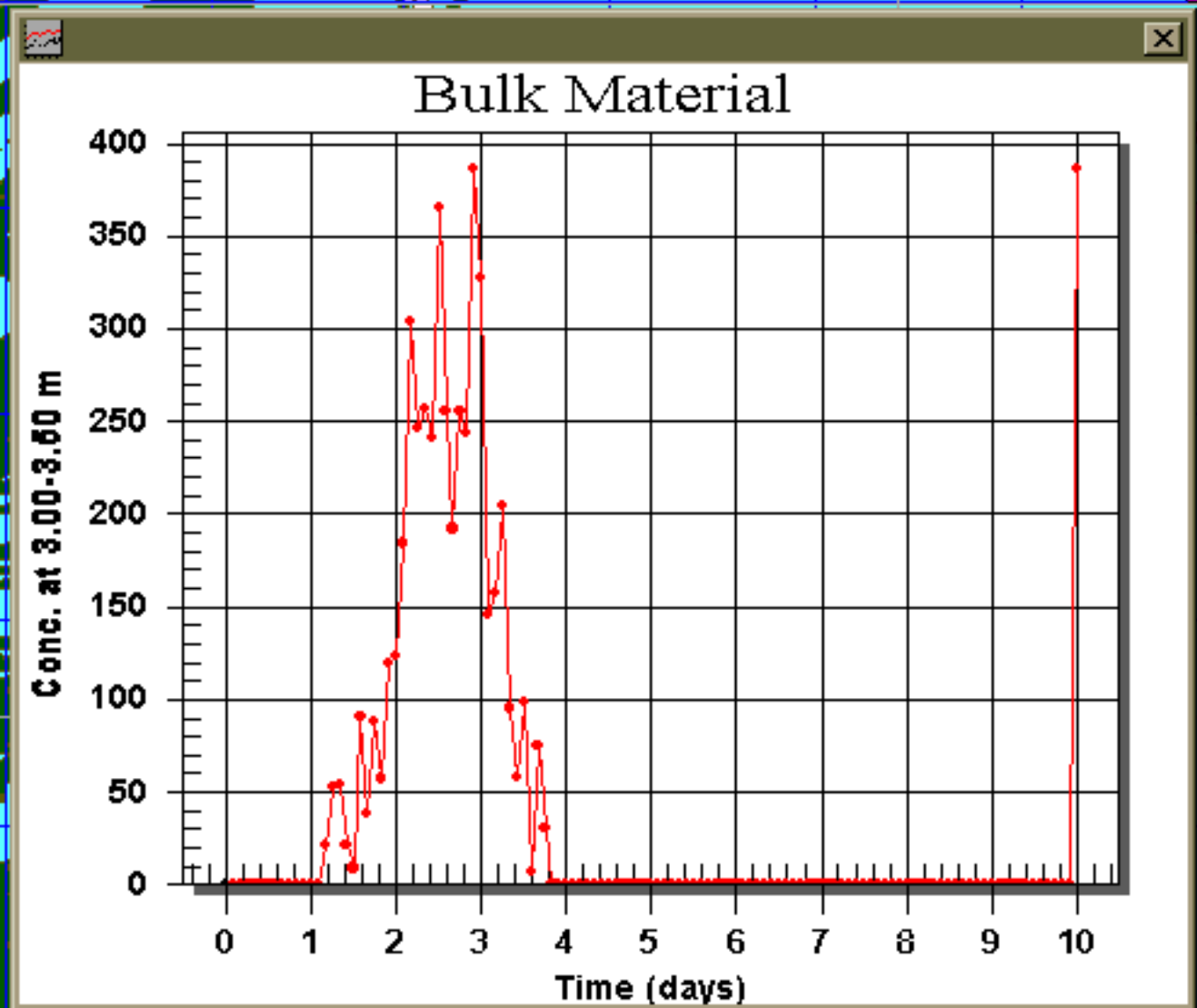

1.5 km
0.8 Nm

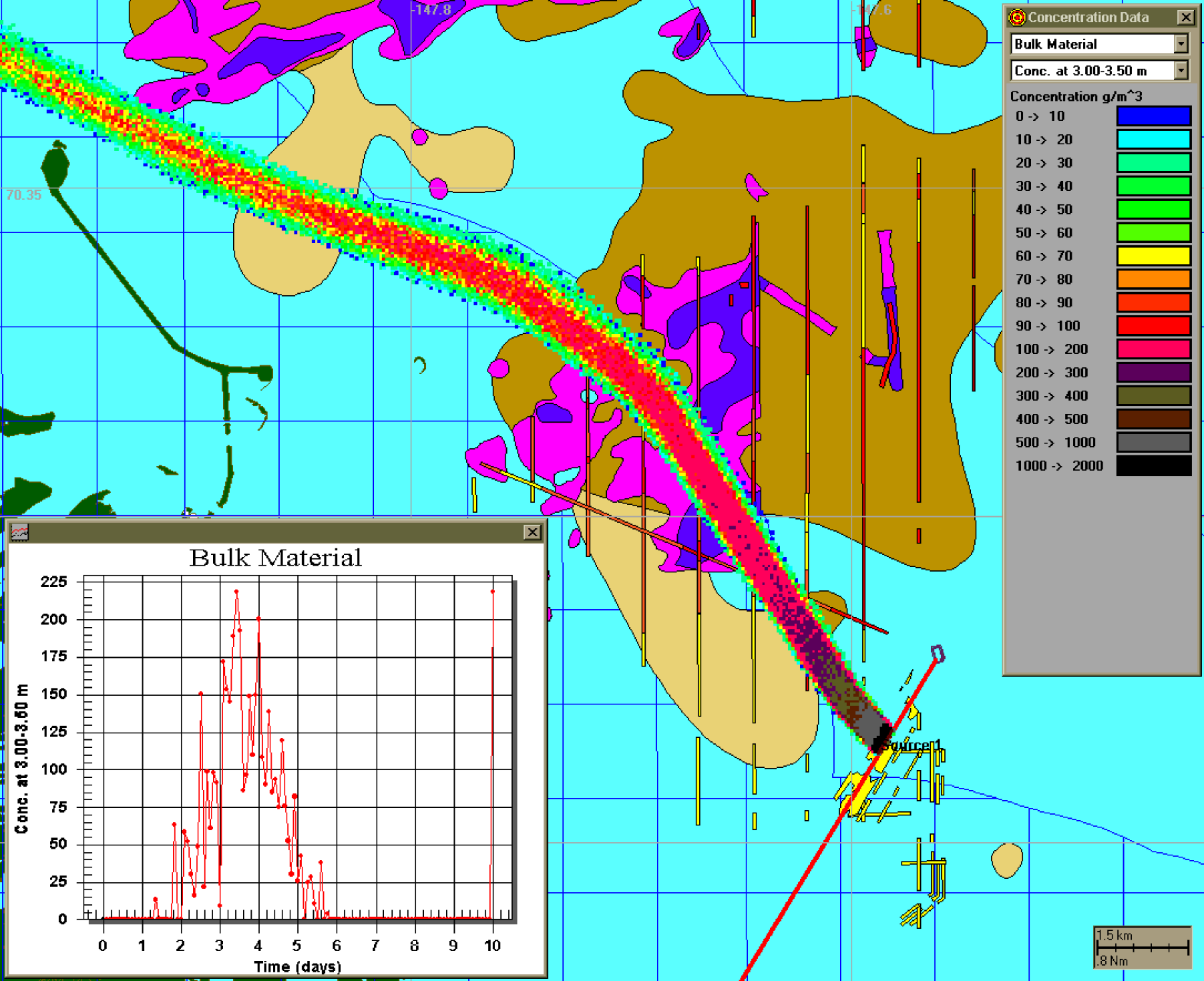

Concentration Data

Bulk Material

Conc. at 3.00-3.50 m

Concentration g/m^3

0 -> 10	Blue
10 -> 20	Cyan
20 -> 30	Light Green
30 -> 40	Green
40 -> 50	Yellow-Green
50 -> 60	Yellow
60 -> 70	Orange
70 -> 80	Red-Orange
80 -> 90	Red
90 -> 100	Dark Red
100 -> 200	Magenta
200 -> 300	Dark Purple
300 -> 400	Olive Green
400 -> 500	Brown
500 -> 1000	Grey
1000 -> 2000	Black

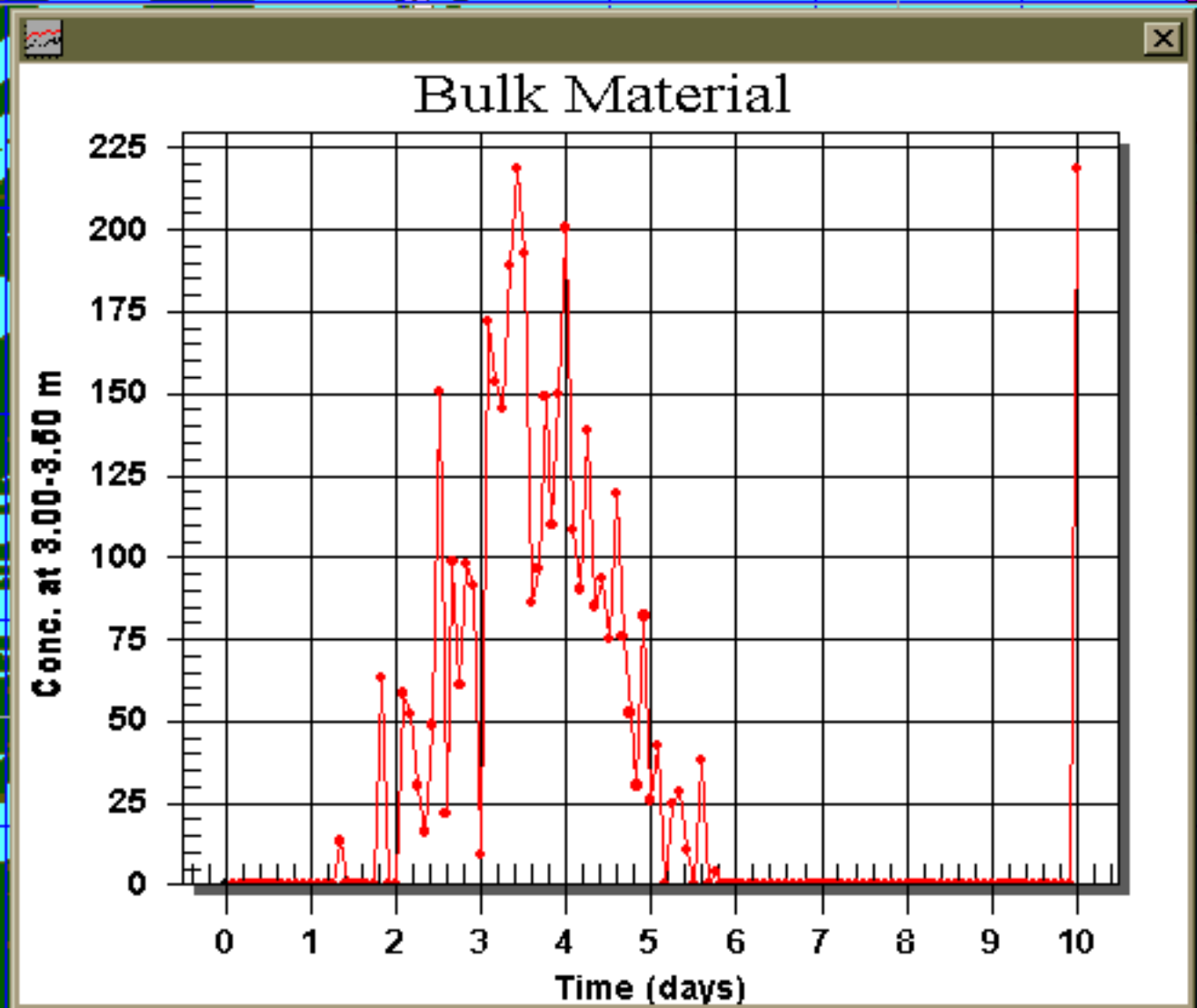

1.5 km
0.8 Nm

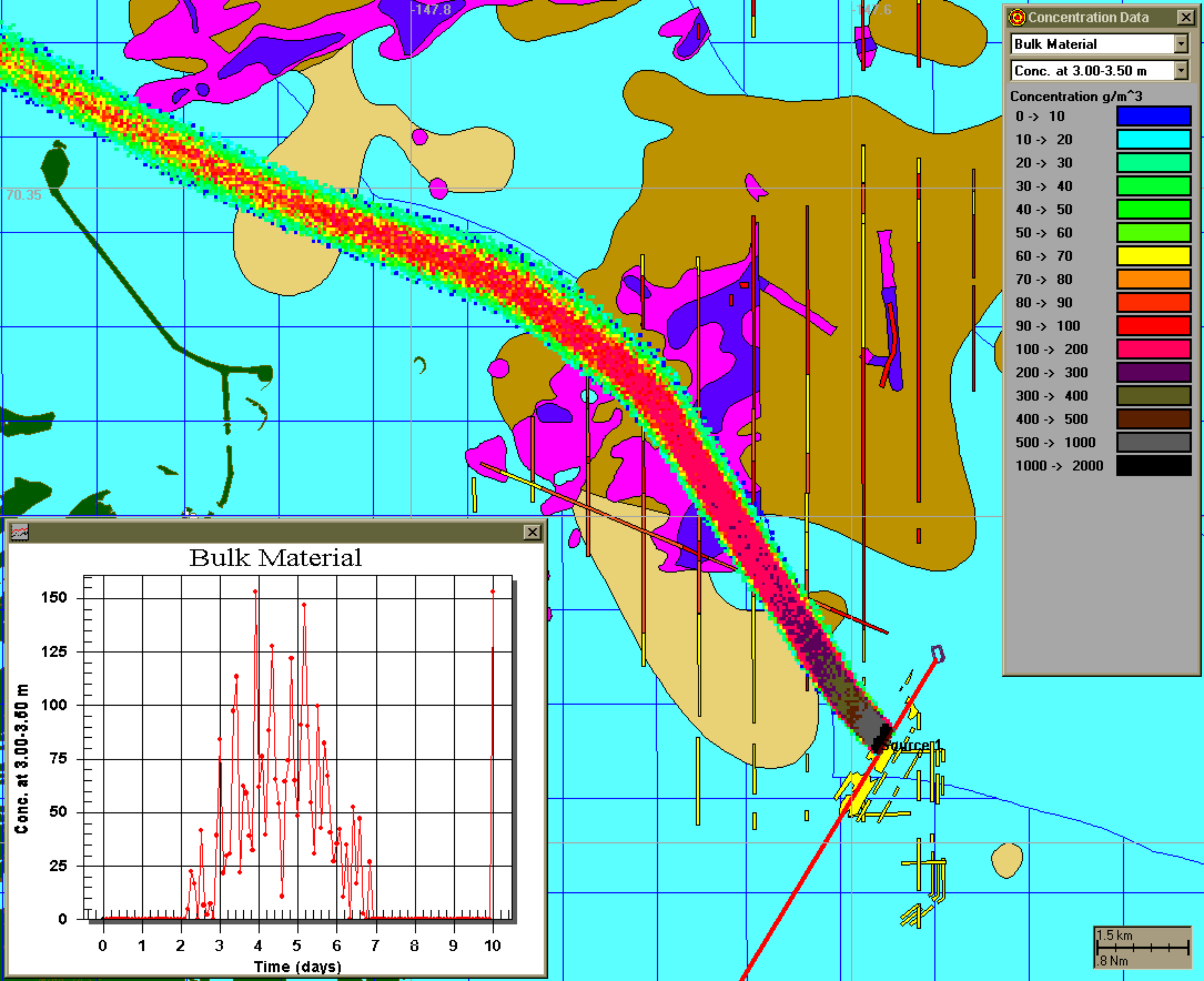

Concentration Data

Bulk Material

Conc. at 3.00-3.50 m

Concentration g/m^3

0 -> 10	Blue
10 -> 20	Cyan
20 -> 30	Light Green
30 -> 40	Green
40 -> 50	Bright Green
50 -> 60	Yellow-Green
60 -> 70	Yellow
70 -> 80	Orange
80 -> 90	Red-Orange
90 -> 100	Red
100 -> 200	Magenta
200 -> 300	Dark Purple
300 -> 400	Olive Green
400 -> 500	Brown
500 -> 1000	Grey
1000 -> 2000	Black

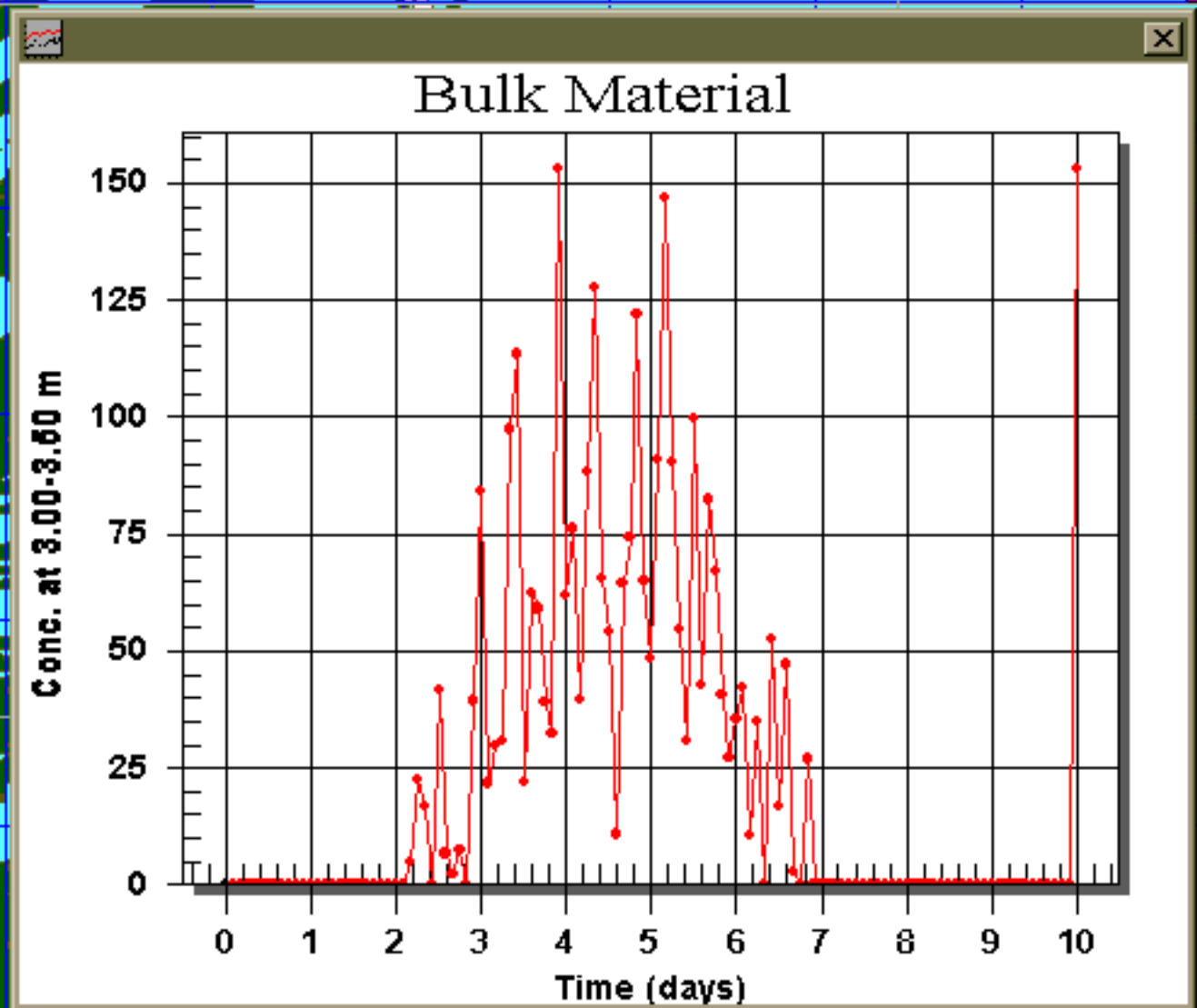

1.5 km
.8 Nm

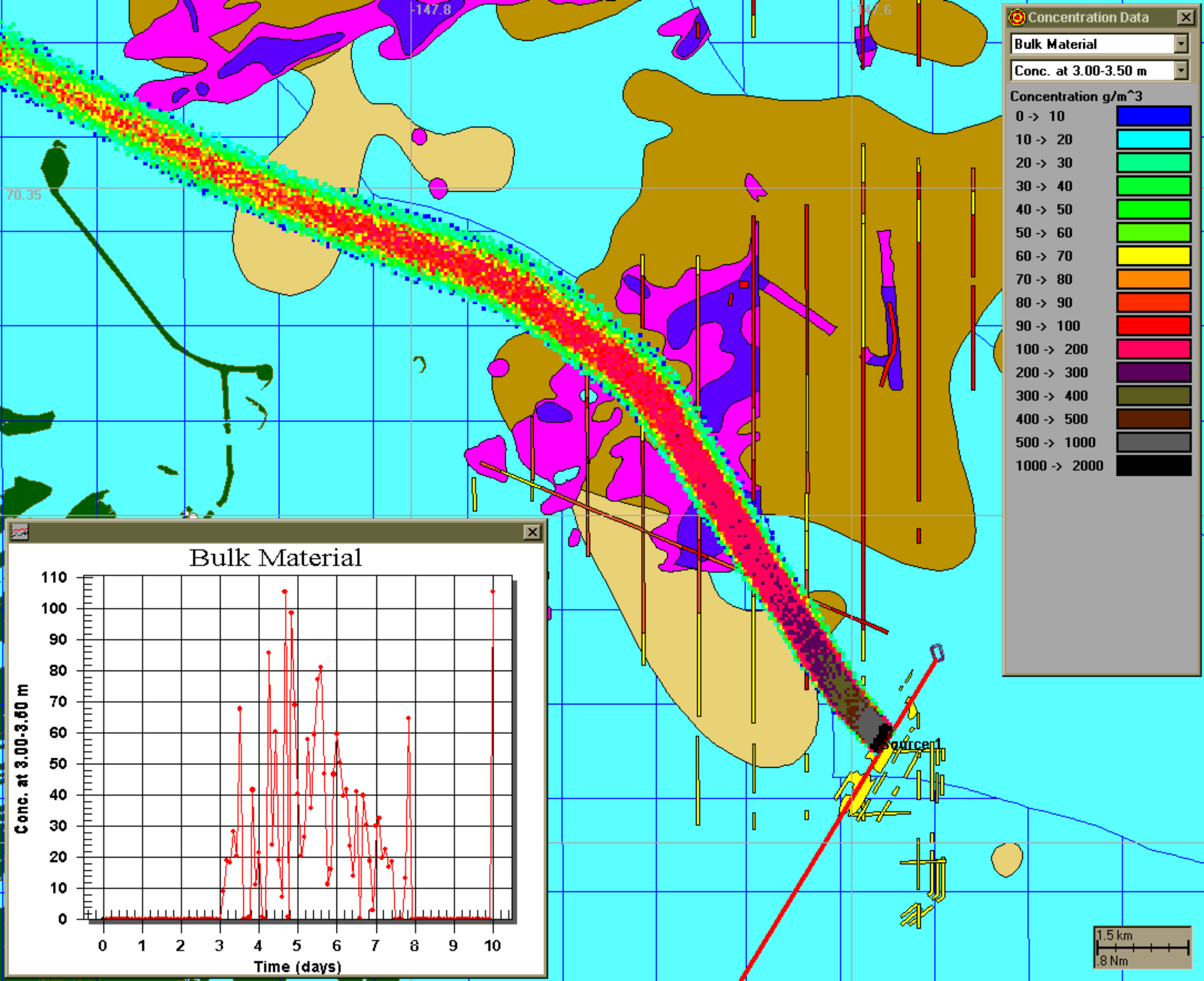

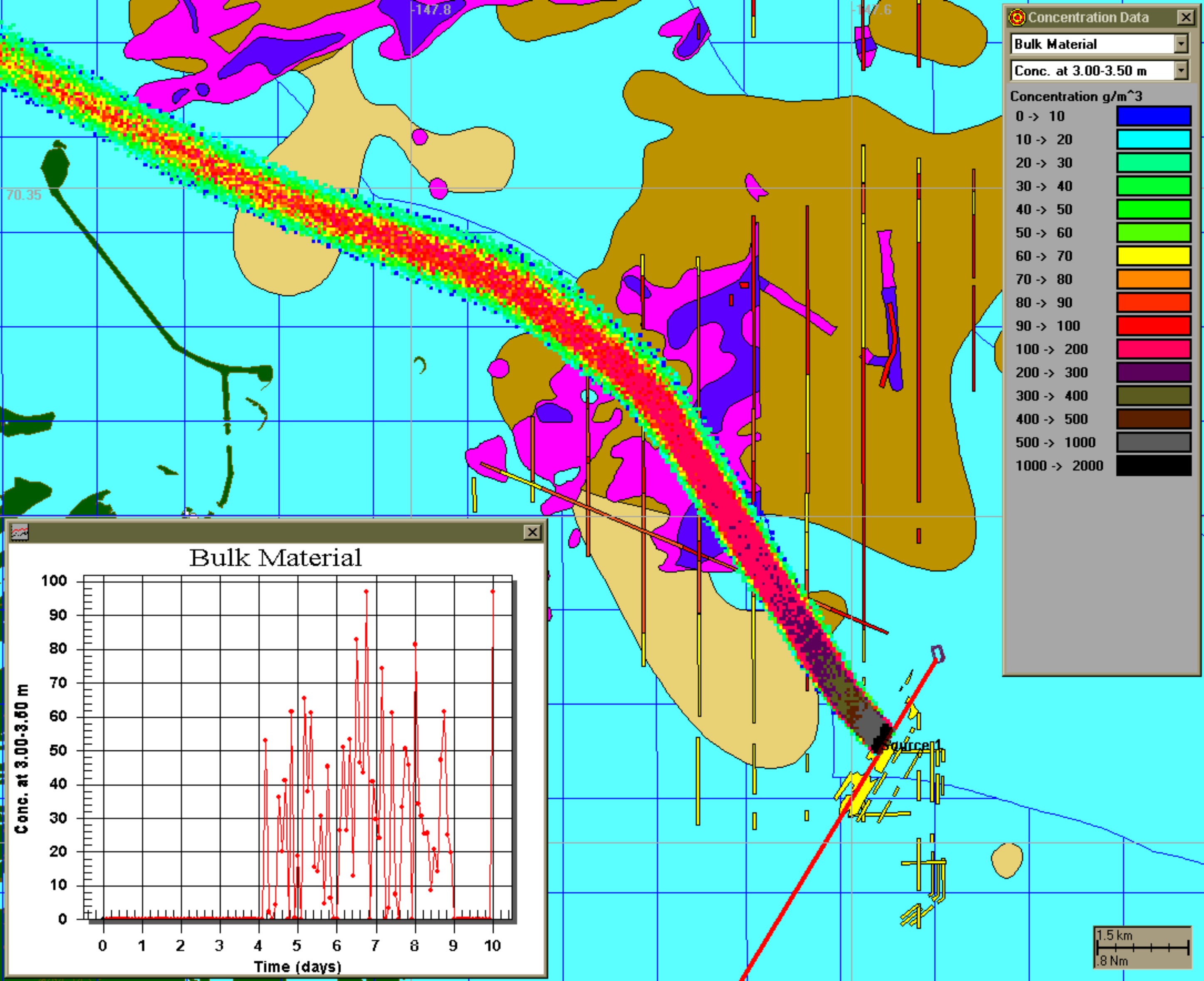

Concentration Data

Bulk Material

Conc. at 3.00-3.50 m

Concentration g/m^3

0 -> 10	Blue
10 -> 20	Cyan
20 -> 30	Light Green
30 -> 40	Green
40 -> 50	Bright Green
50 -> 60	Yellow-Green
60 -> 70	Yellow
70 -> 80	Orange
80 -> 90	Red-Orange
90 -> 100	Red
100 -> 200	Magenta
200 -> 300	Purple
300 -> 400	Olive
400 -> 500	Brown
500 -> 1000	Grey
1000 -> 2000	Black

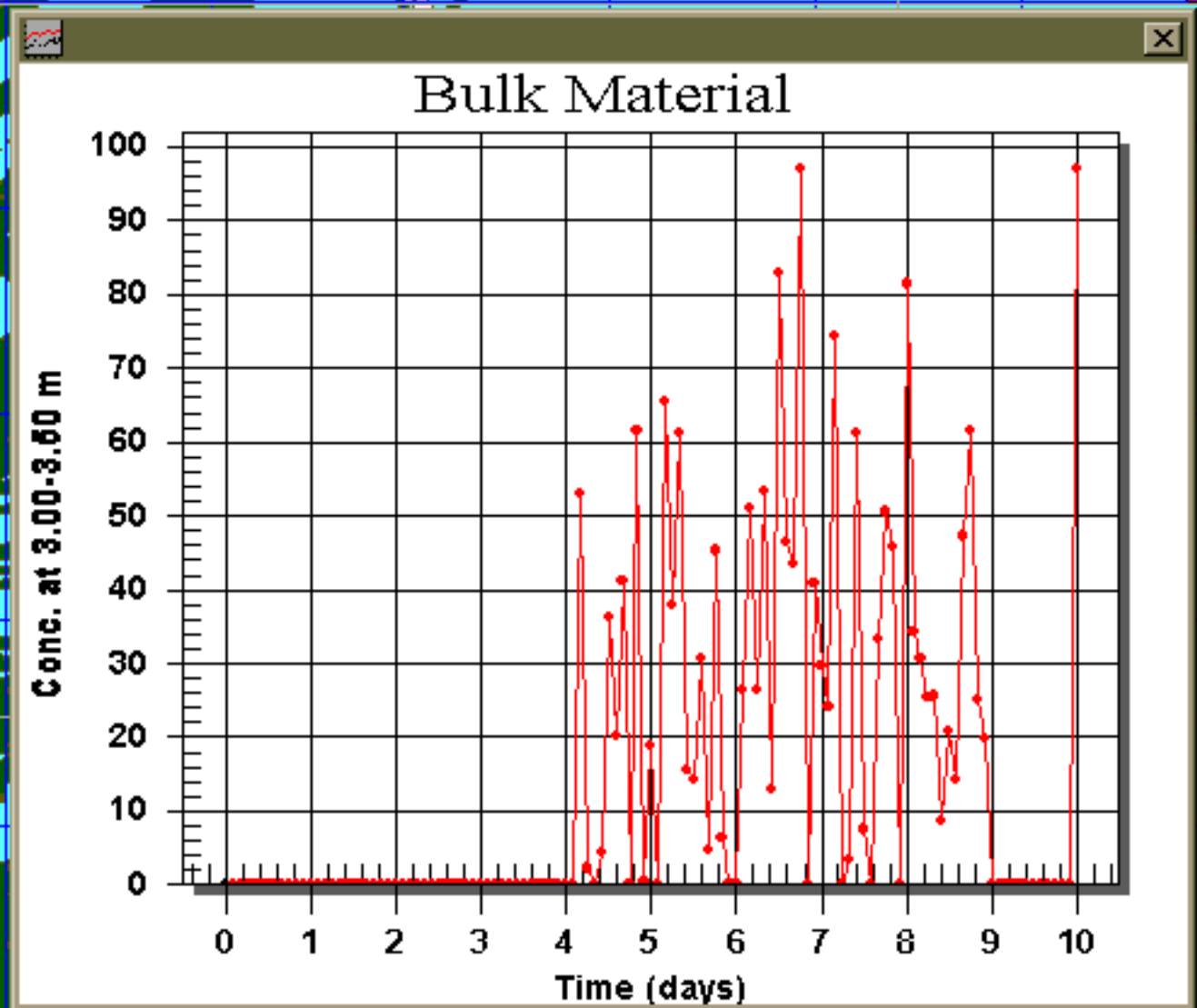

1.5 km
.8 Nm

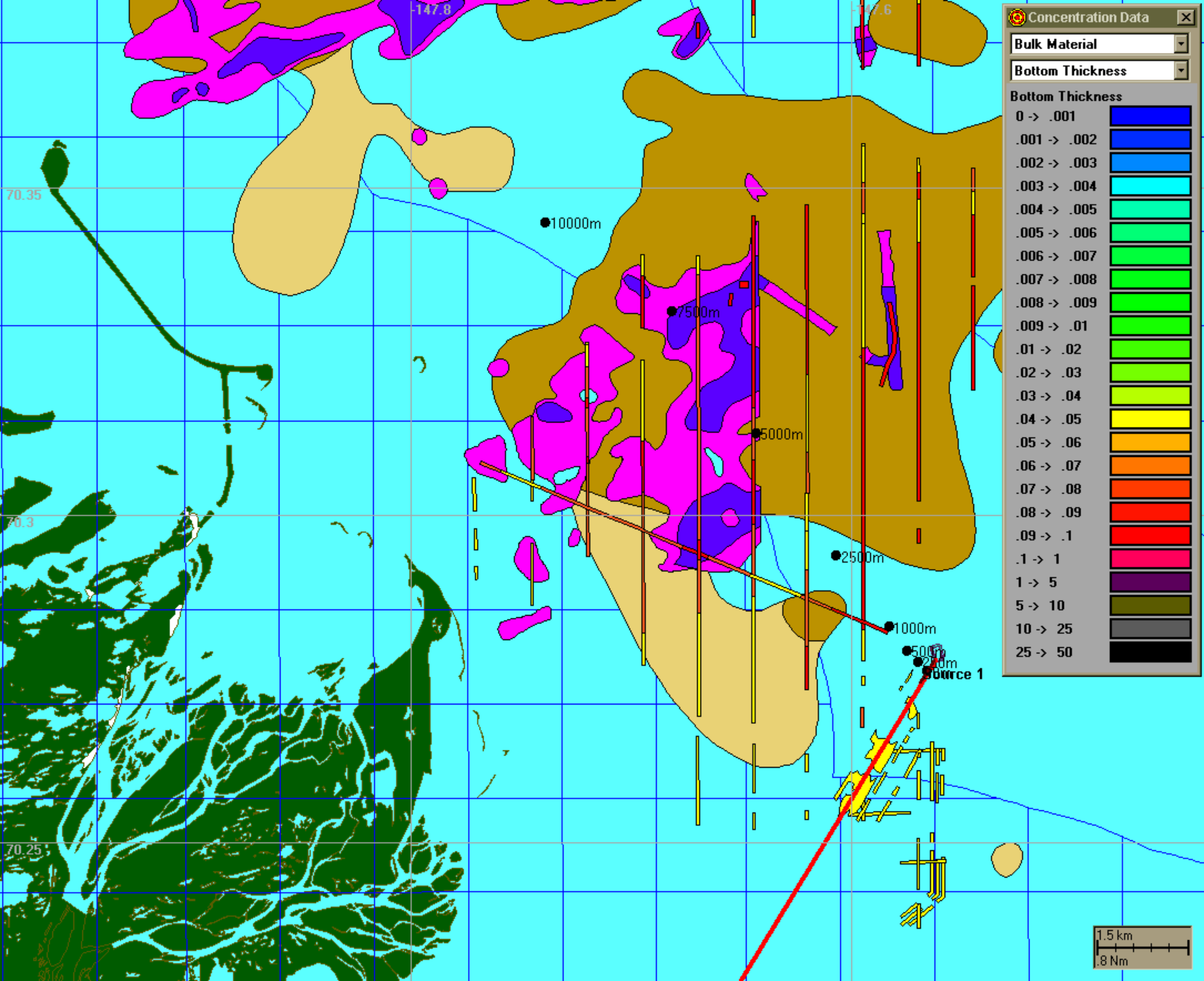

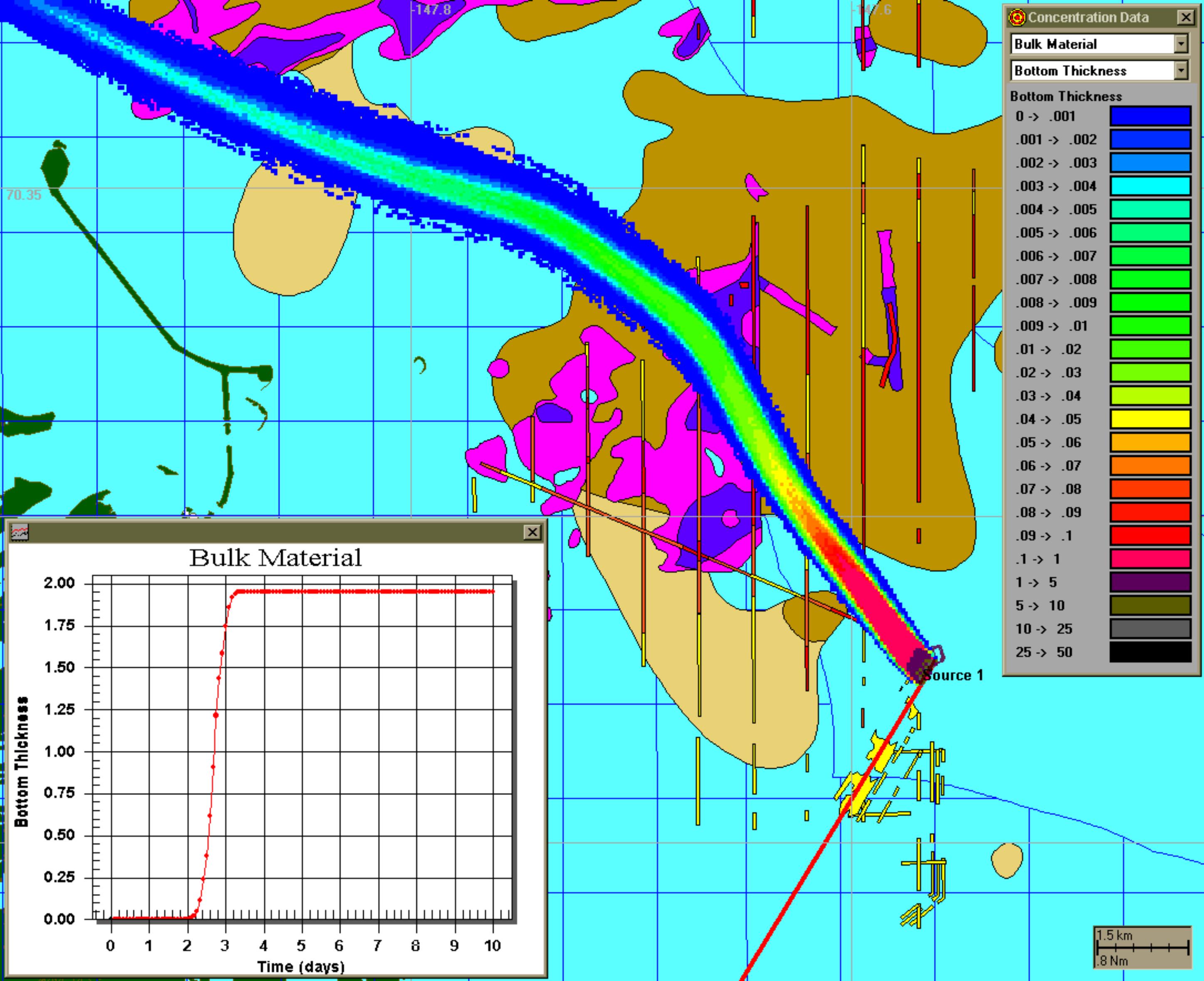

Concentration Data

Bulk Material

Bottom Thickness

Bottom Thickness

0 -> .001	[Dark Blue]
.001 -> .002	[Blue]
.002 -> .003	[Light Blue]
.003 -> .004	[Cyan]
.004 -> .005	[Green-Cyan]
.005 -> .006	[Green]
.006 -> .007	[Light Green]
.007 -> .008	[Green]
.008 -> .009	[Light Green]
.009 -> .01	[Green]
.01 -> .02	[Light Green]
.02 -> .03	[Yellow-Green]
.03 -> .04	[Yellow]
.04 -> .05	[Light Yellow]
.05 -> .06	[Orange]
.06 -> .07	[Red-Orange]
.07 -> .08	[Red]
.08 -> .09	[Dark Red]
.09 -> .1	[Red]
.1 -> 1	[Magenta]
1 -> 5	[Purple]
5 -> 10	[Dark Purple]
10 -> 25	[Grey]
25 -> 50	[Black]

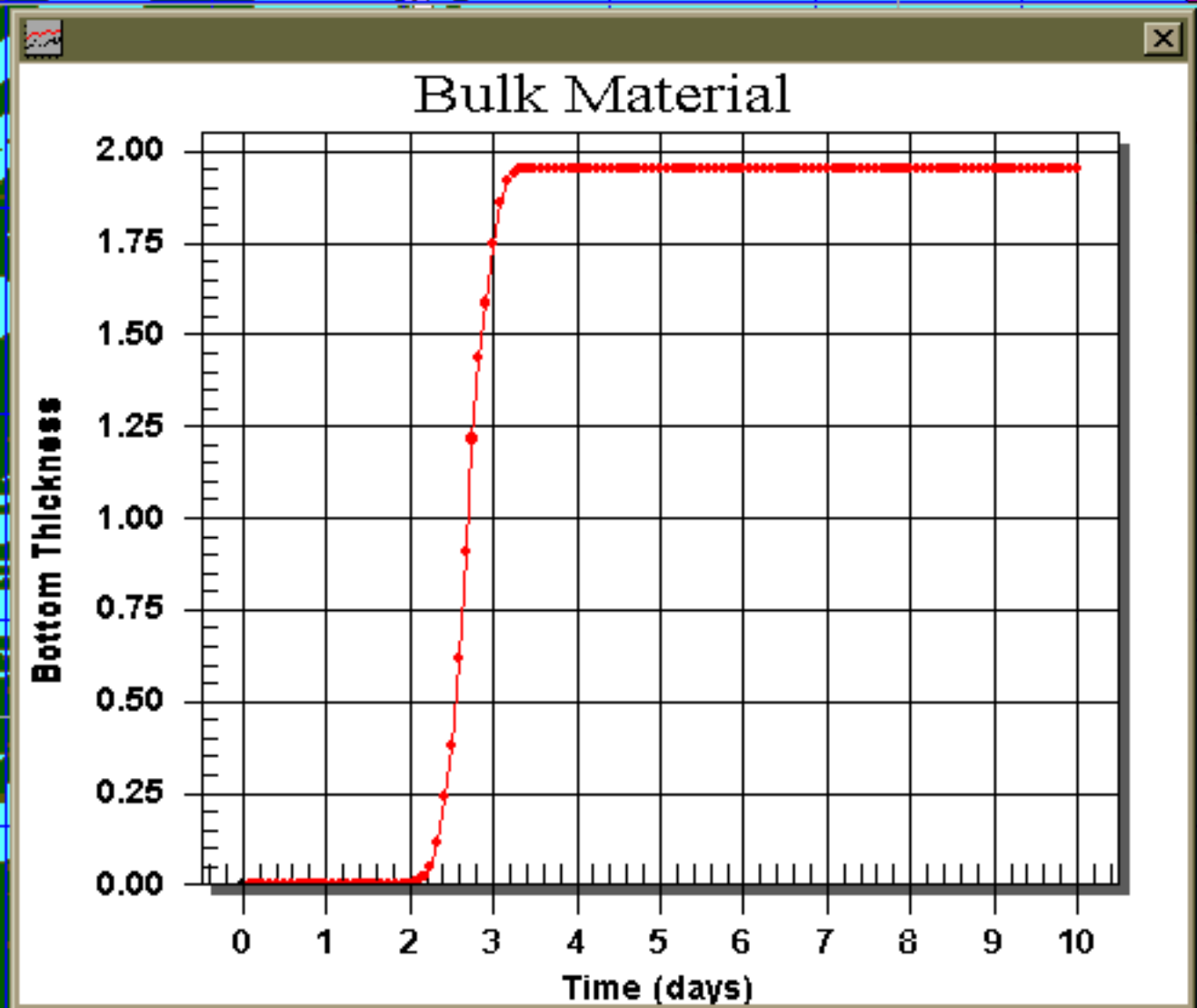

1.5 km
0.8 Nm

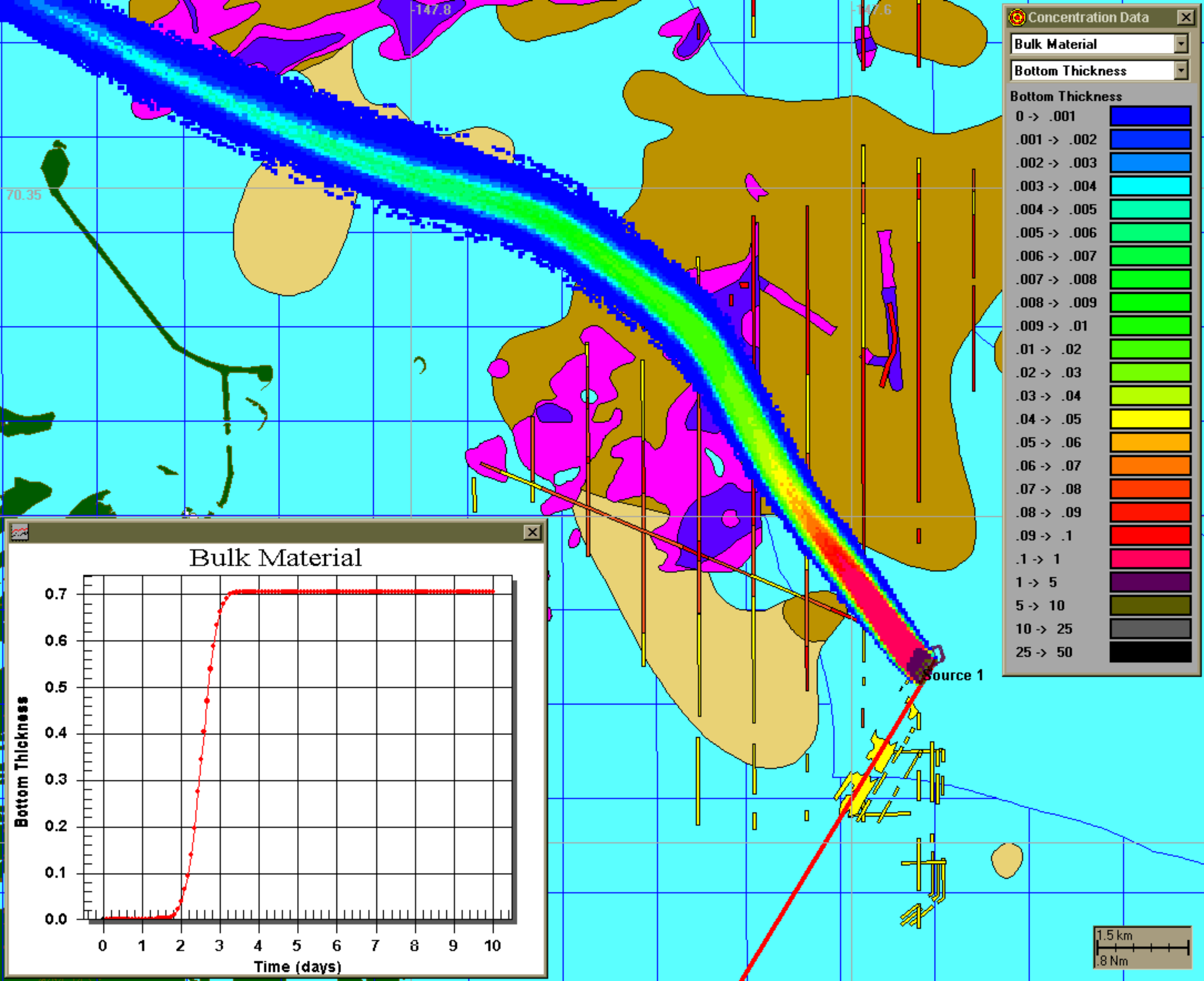

Concentration Data

Bulk Material

Bottom Thickness

Bottom Thickness

0 -> .001	[Dark Blue]
.001 -> .002	[Blue]
.002 -> .003	[Light Blue]
.003 -> .004	[Cyan]
.004 -> .005	[Green-Cyan]
.005 -> .006	[Green]
.006 -> .007	[Light Green]
.007 -> .008	[Green]
.008 -> .009	[Light Green]
.009 -> .01	[Green]
.01 -> .02	[Light Green]
.02 -> .03	[Yellow-Green]
.03 -> .04	[Yellow]
.04 -> .05	[Light Orange]
.05 -> .06	[Orange]
.06 -> .07	[Red-Orange]
.07 -> .08	[Red]
.08 -> .09	[Dark Red]
.09 -> .1	[Red]
.1 -> 1	[Magenta]
1 -> 5	[Purple]
5 -> 10	[Dark Purple]
10 -> 25	[Grey]
25 -> 50	[Black]

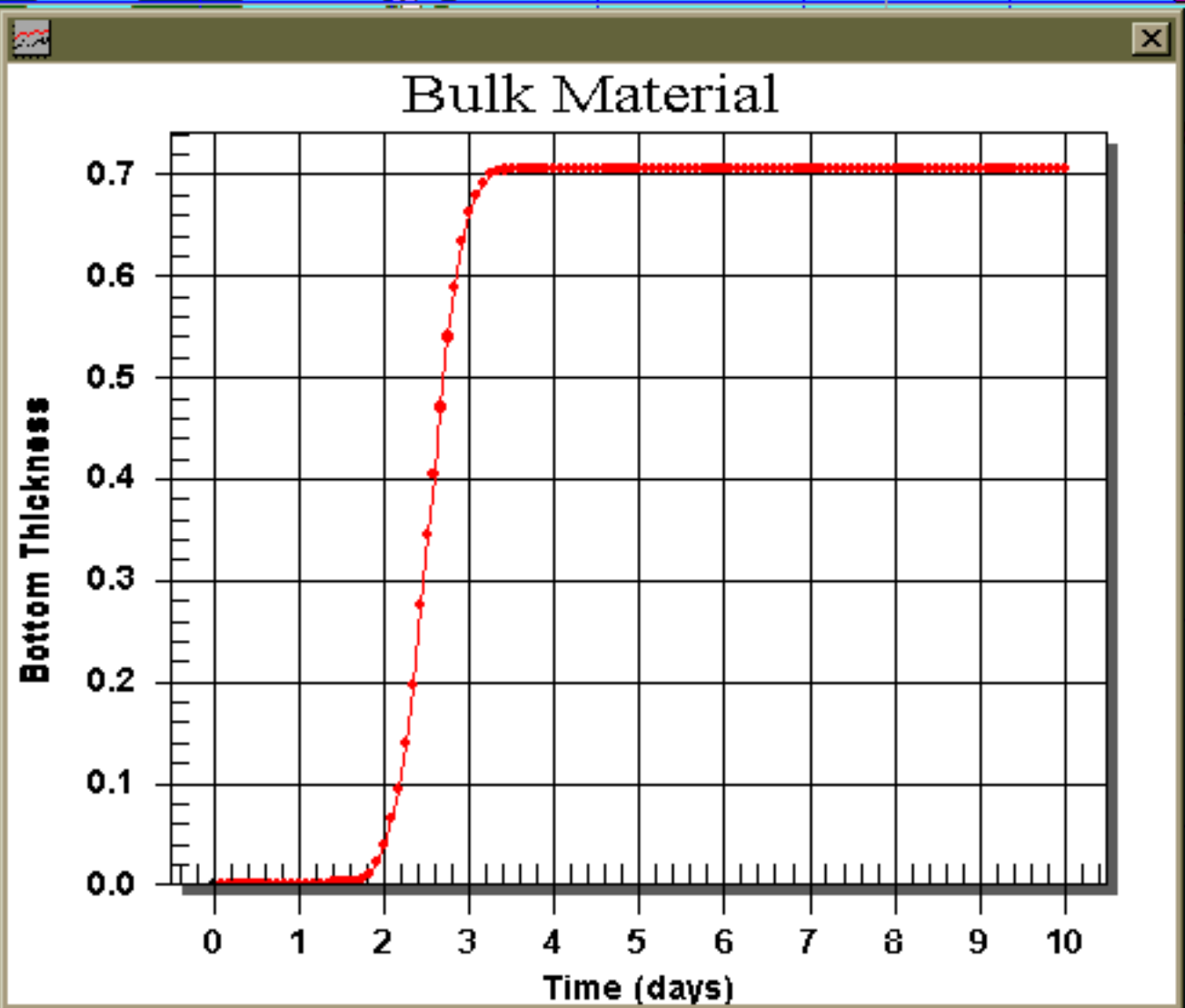

1.5 km
.8 Nm

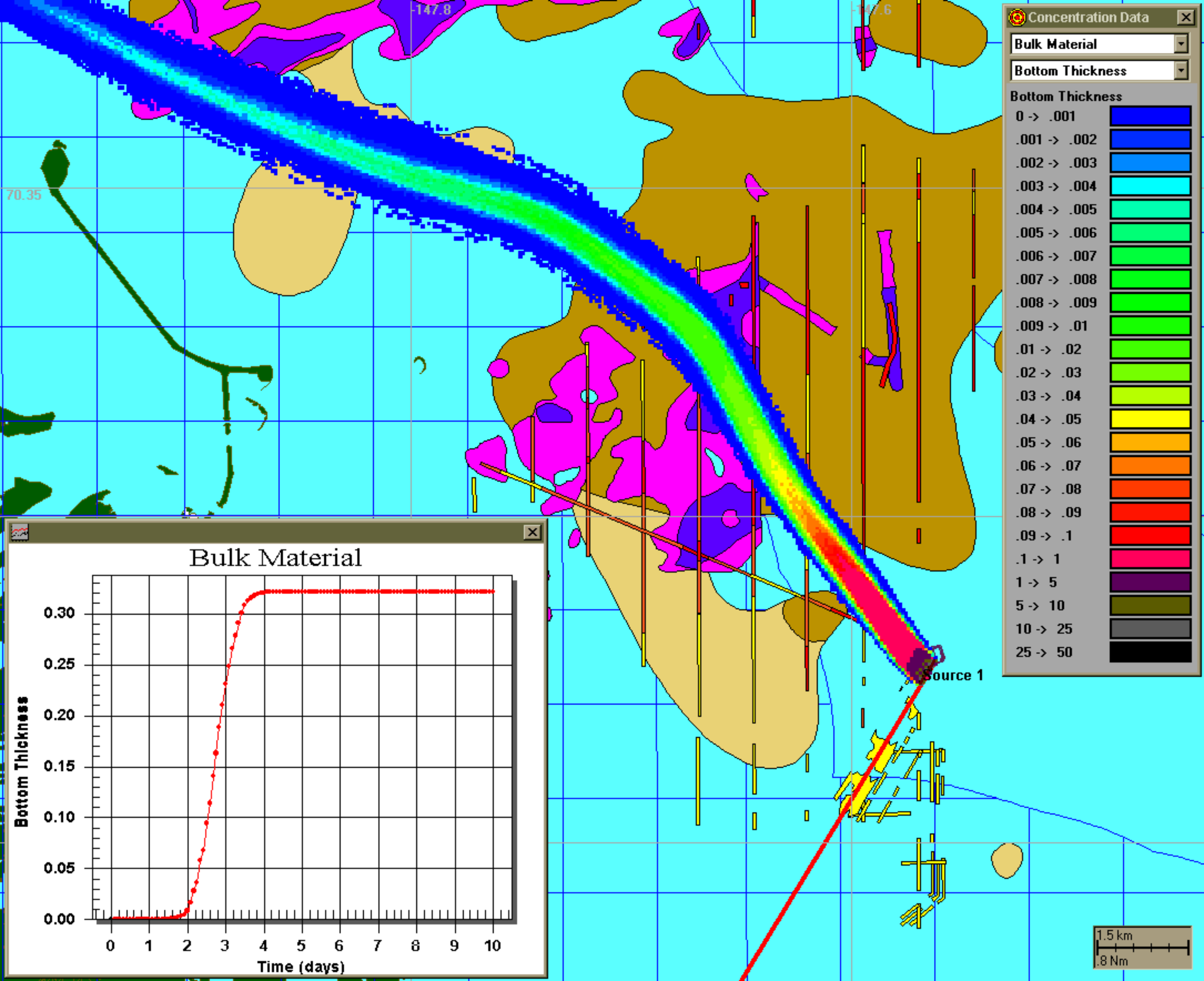

Concentration Data

Bulk Material

Bottom Thickness

Bottom Thickness

0 -> .001	[Dark Blue]
.001 -> .002	[Blue]
.002 -> .003	[Light Blue]
.003 -> .004	[Cyan]
.004 -> .005	[Green-Cyan]
.005 -> .006	[Green]
.006 -> .007	[Light Green]
.007 -> .008	[Green]
.008 -> .009	[Light Green]
.009 -> .01	[Green]
.01 -> .02	[Light Green]
.02 -> .03	[Yellow-Green]
.03 -> .04	[Yellow]
.04 -> .05	[Light Orange]
.05 -> .06	[Orange]
.06 -> .07	[Red-Orange]
.07 -> .08	[Red]
.08 -> .09	[Dark Red]
.09 -> .1	[Red]
.1 -> 1	[Magenta]
1 -> 5	[Purple]
5 -> 10	[Dark Purple]
10 -> 25	[Grey]
25 -> 50	[Black]

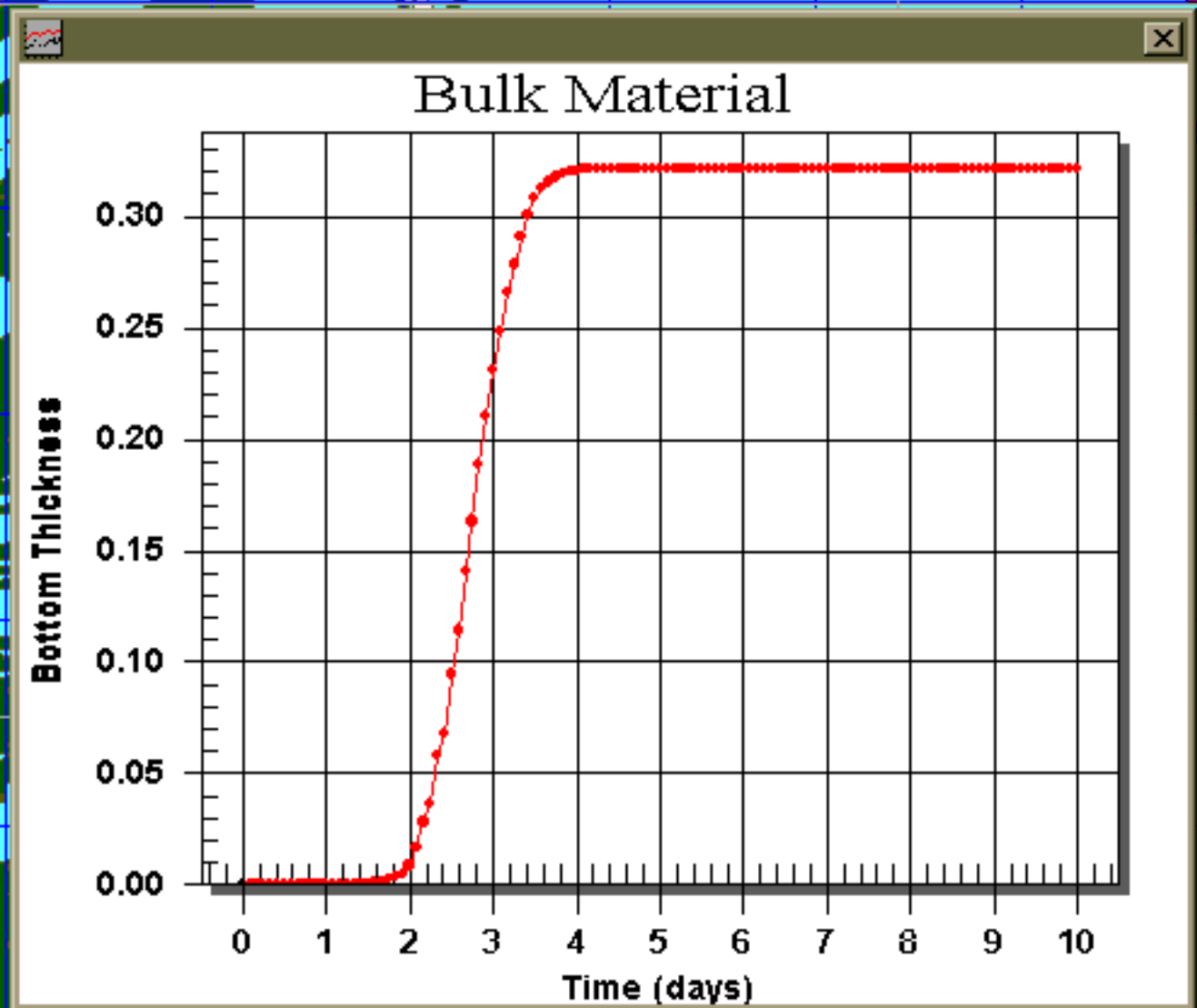

1.5 km
0.8 Nm

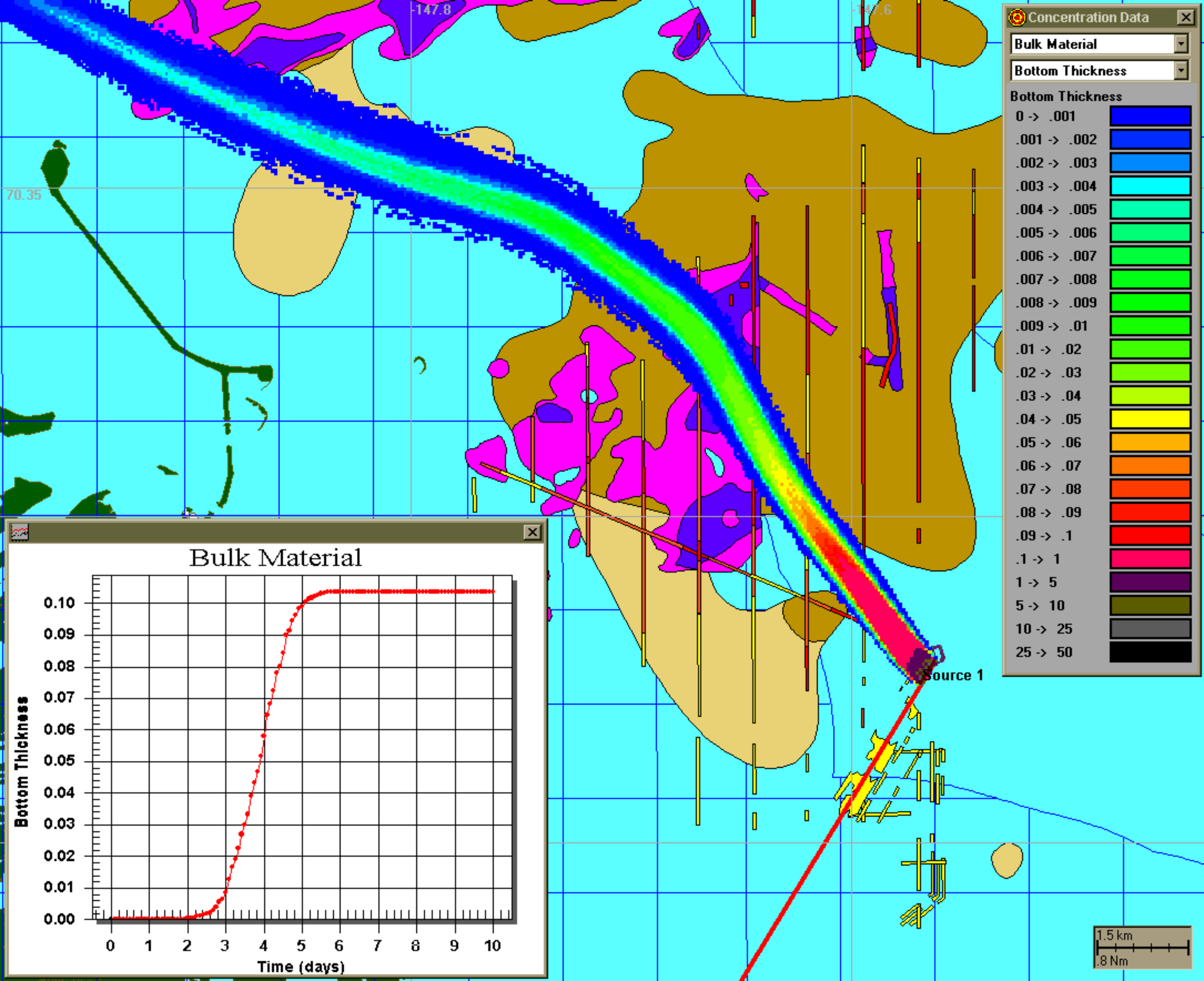

Concentration Data

Bulk Material

Bottom Thickness

Bottom Thickness

0 -> .001	[Blue]
.001 -> .002	[Blue]
.002 -> .003	[Light Blue]
.003 -> .004	[Cyan]
.004 -> .005	[Green-Cyan]
.005 -> .006	[Green]
.006 -> .007	[Light Green]
.007 -> .008	[Green]
.008 -> .009	[Light Green]
.009 -> .01	[Green]
.01 -> .02	[Light Green]
.02 -> .03	[Yellow-Green]
.03 -> .04	[Yellow]
.04 -> .05	[Light Orange]
.05 -> .06	[Orange]
.06 -> .07	[Red-Orange]
.07 -> .08	[Red]
.08 -> .09	[Dark Red]
.09 -> .1	[Red]
.1 -> 1	[Pink]
1 -> 5	[Purple]
5 -> 10	[Dark Purple]
10 -> 25	[Grey]
25 -> 50	[Black]

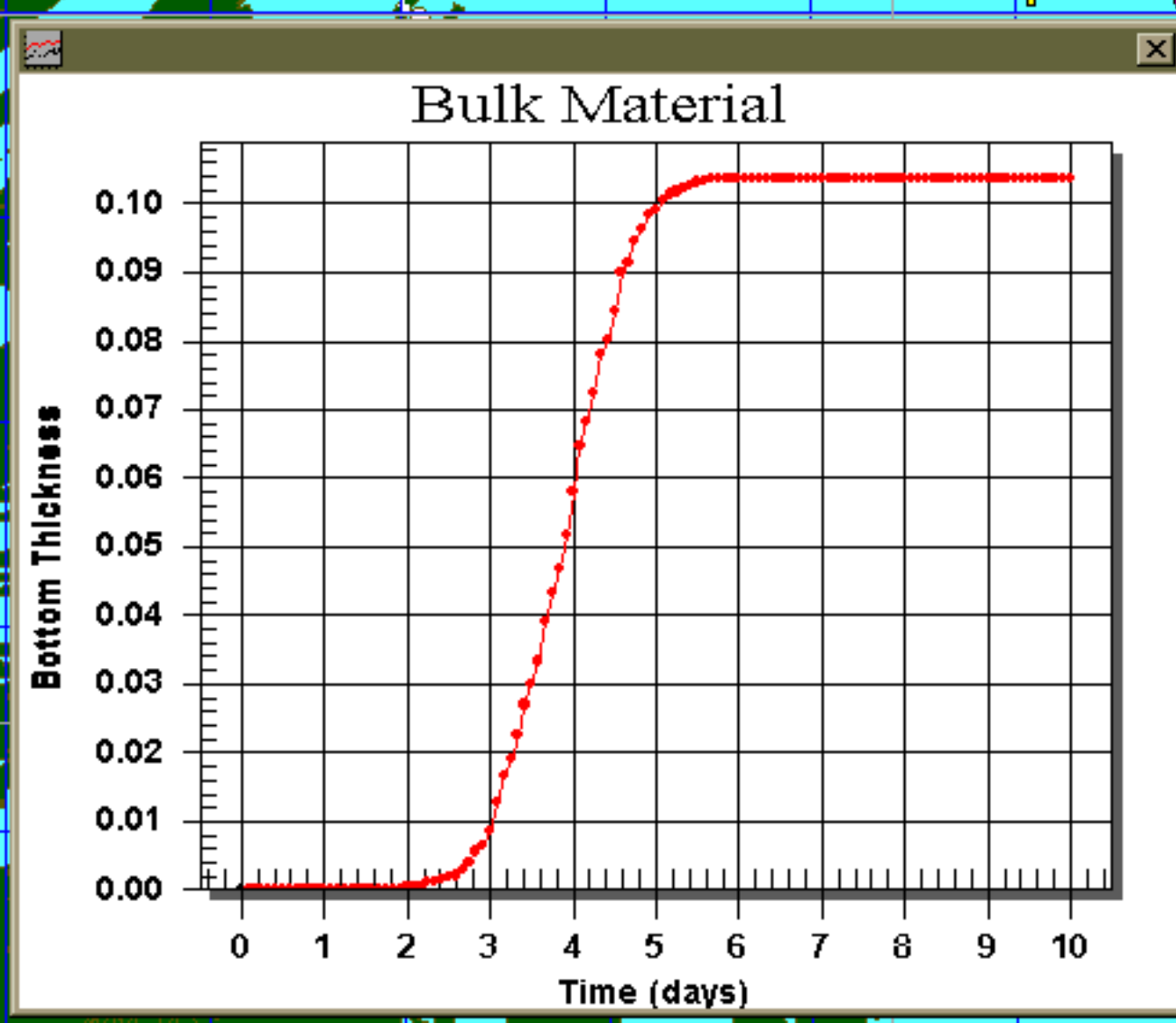

1.5 km
0.8 Nm

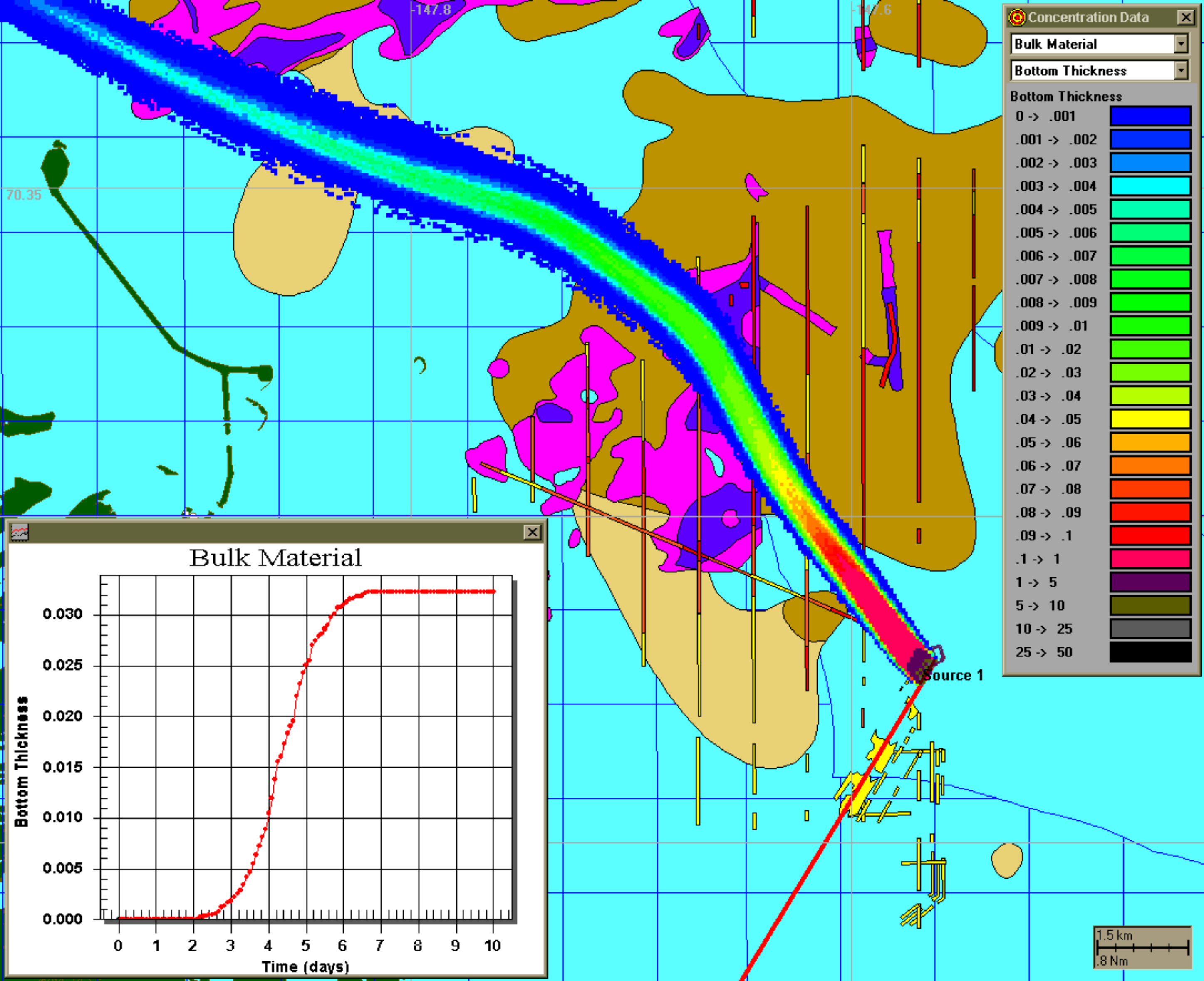

Bulk Material

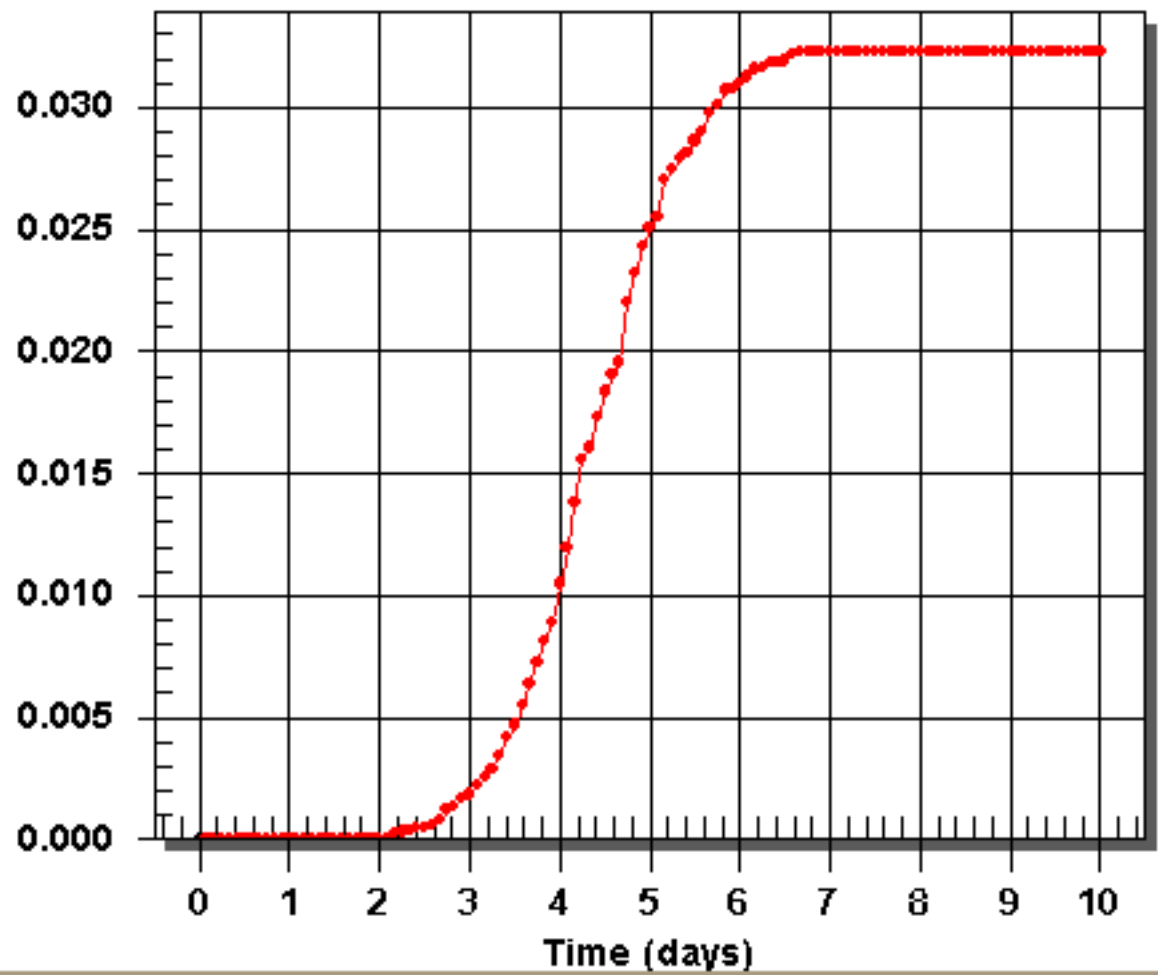

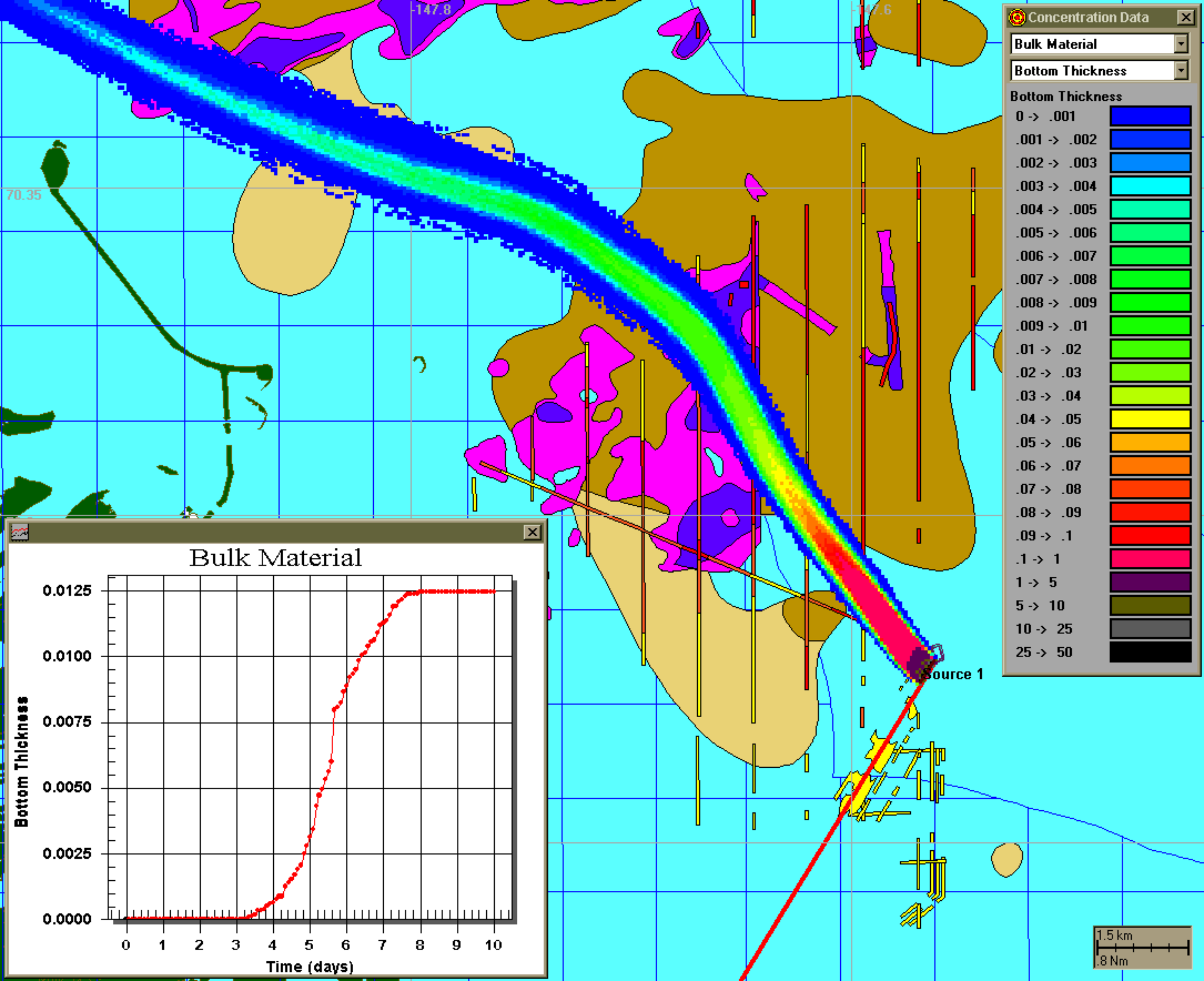

Concentration Data

Bulk Material

Bottom Thickness

Bottom Thickness

0 -> .001	[Blue]
.001 -> .002	[Light Blue]
.002 -> .003	[Cyan]
.003 -> .004	[Green-Cyan]
.004 -> .005	[Green]
.005 -> .006	[Light Green]
.006 -> .007	[Yellow-Green]
.007 -> .008	[Yellow]
.008 -> .009	[Orange-Yellow]
.009 -> .01	[Orange]
.01 -> .02	[Red-Orange]
.02 -> .03	[Red]
.03 -> .04	[Dark Red]
.04 -> .05	[Magenta]
.05 -> .06	[Purple-Magenta]
.06 -> .07	[Purple]
.07 -> .08	[Dark Purple]
.08 -> .09	[Black-Purple]
.09 -> .1	[Black]
.1 -> 1	[Dark Grey]
1 -> 5	[Grey]
5 -> 10	[Light Grey]
10 -> 25	[White]
25 -> 50	[Black]

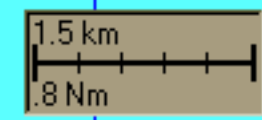
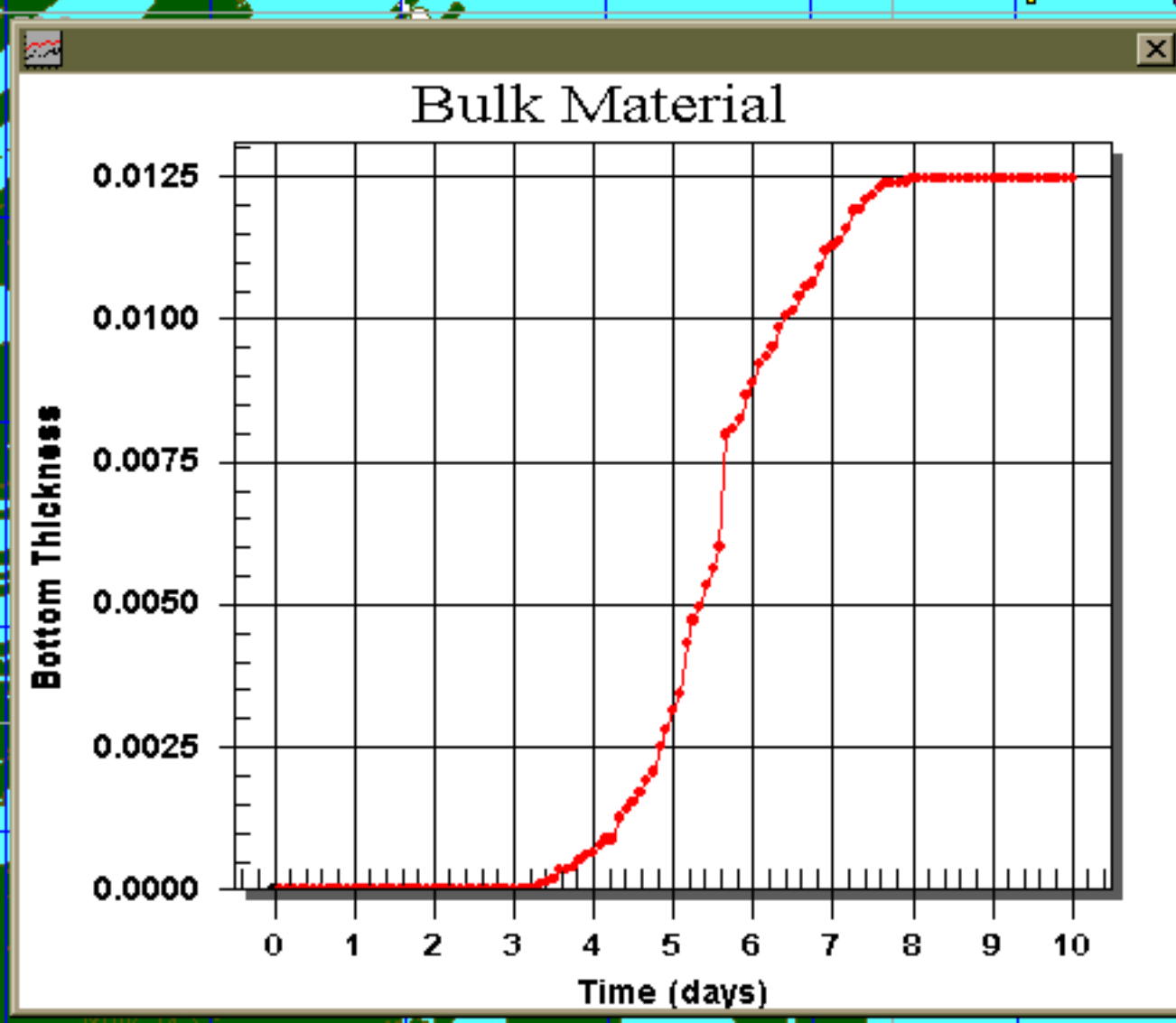

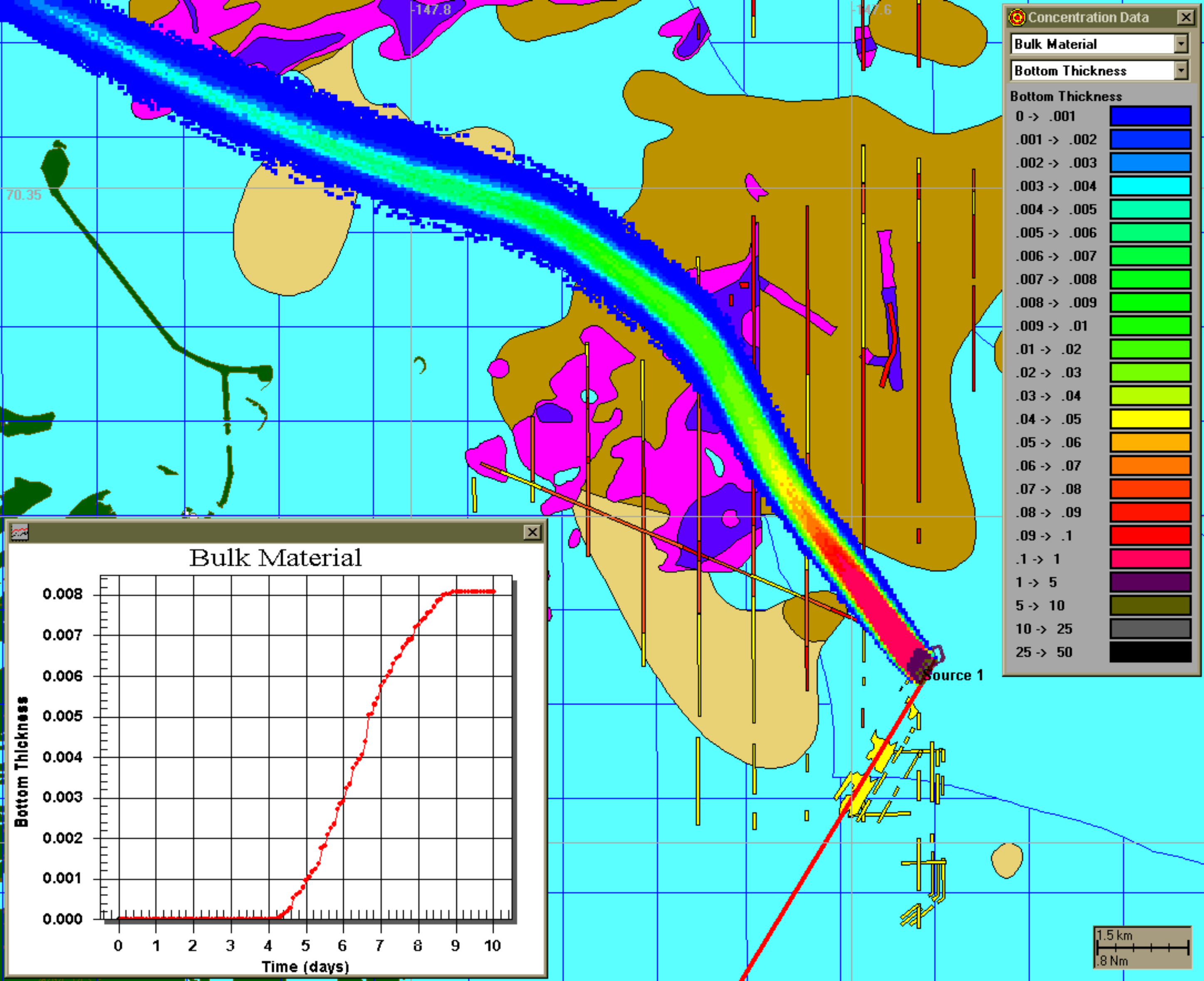

Concentration Data

Bulk Material

Bottom Thickness

Bottom Thickness

0 -> .001	[Blue]
.001 -> .002	[Blue]
.002 -> .003	[Light Blue]
.003 -> .004	[Cyan]
.004 -> .005	[Green-Cyan]
.005 -> .006	[Green]
.006 -> .007	[Light Green]
.007 -> .008	[Green]
.008 -> .009	[Light Green]
.009 -> .01	[Green]
.01 -> .02	[Light Green]
.02 -> .03	[Yellow-Green]
.03 -> .04	[Yellow]
.04 -> .05	[Yellow-Orange]
.05 -> .06	[Orange]
.06 -> .07	[Red-Orange]
.07 -> .08	[Red]
.08 -> .09	[Red]
.09 -> .1	[Red]
.1 -> 1	[Pink]
1 -> 5	[Purple]
5 -> 10	[Dark Purple]
10 -> 25	[Grey]
25 -> 50	[Black]

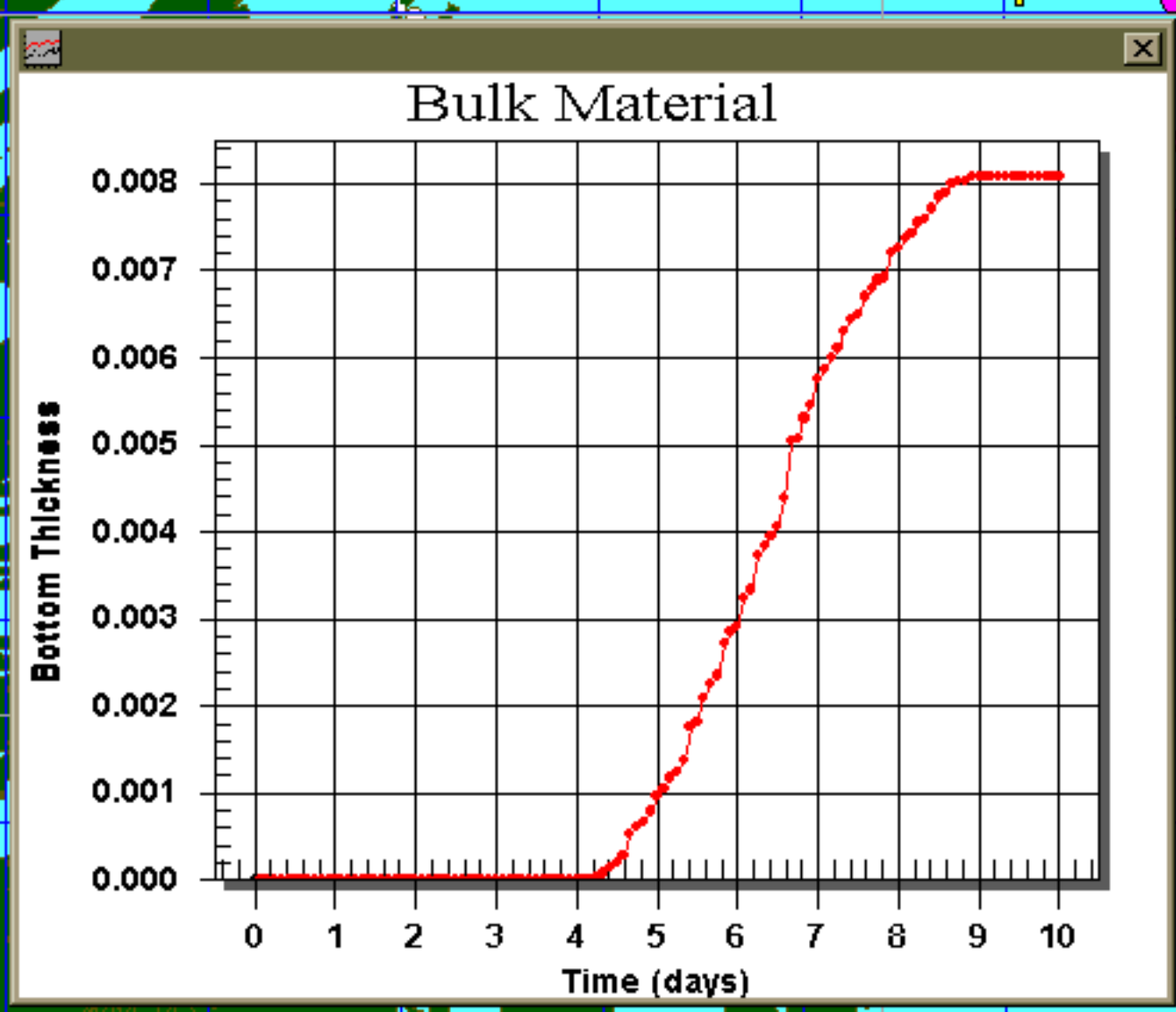

1.5 km
.8 Nm

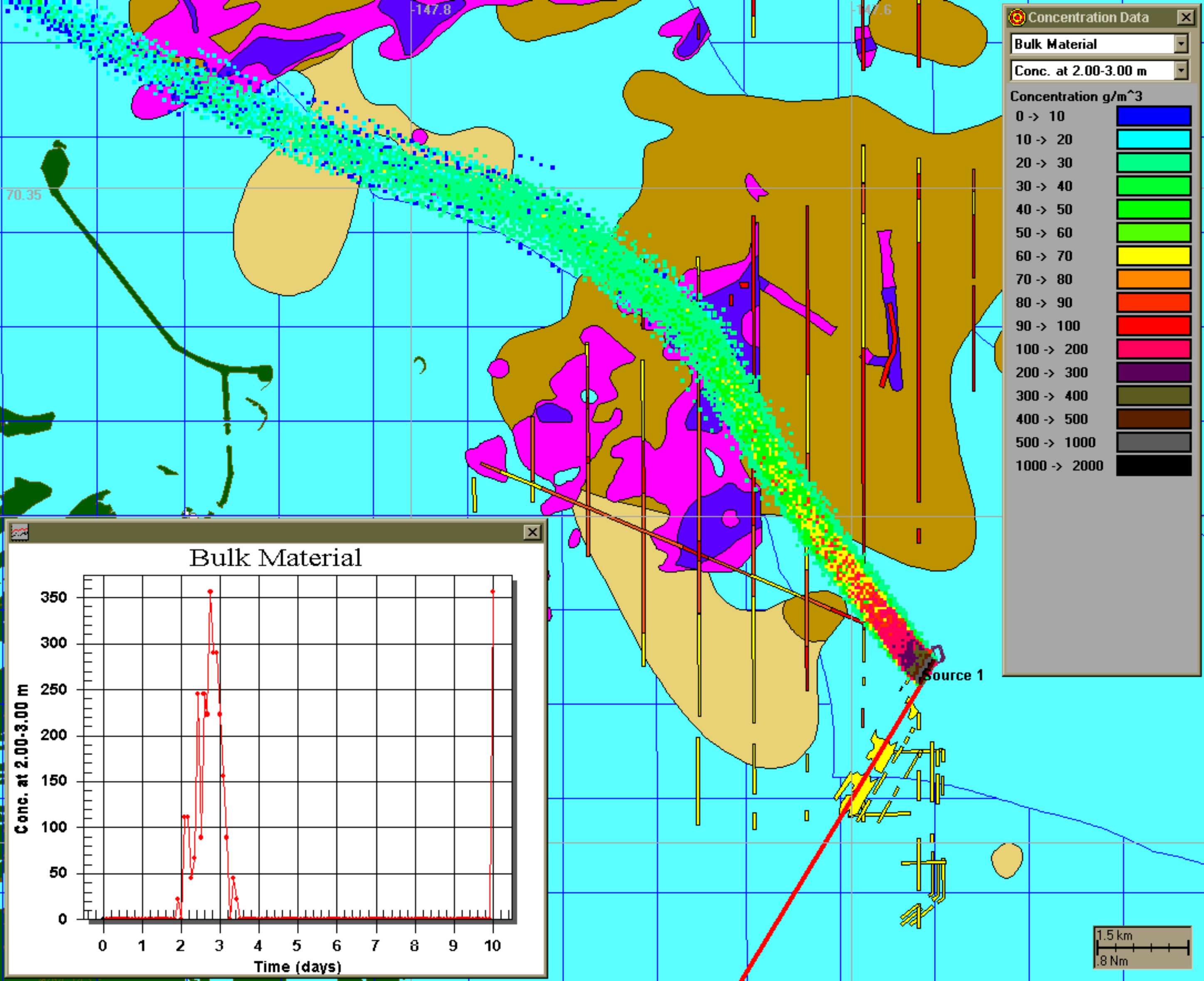

Concentration Data

Bulk Material

Conc. at 2.00-3.00 m

Concentration g/m^3

0 -> 10	Blue
10 -> 20	Cyan
20 -> 30	Green
30 -> 40	Yellow-Green
40 -> 50	Yellow
50 -> 60	Orange
60 -> 70	Red-Orange
70 -> 80	Red
80 -> 90	Magenta
90 -> 100	Purple
100 -> 200	Brown
200 -> 300	Grey
300 -> 400	Black

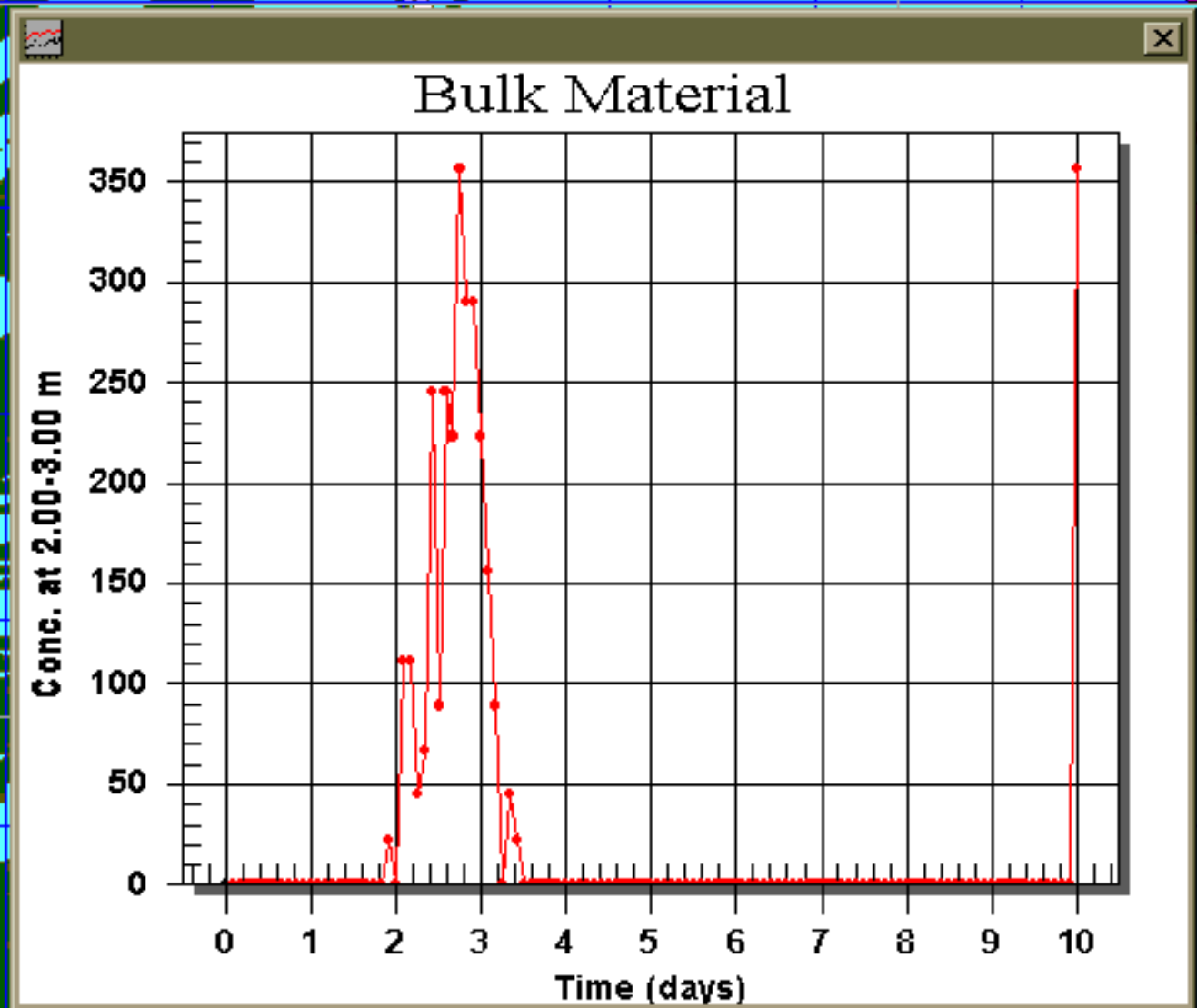

1.5 km
0.8 Nm

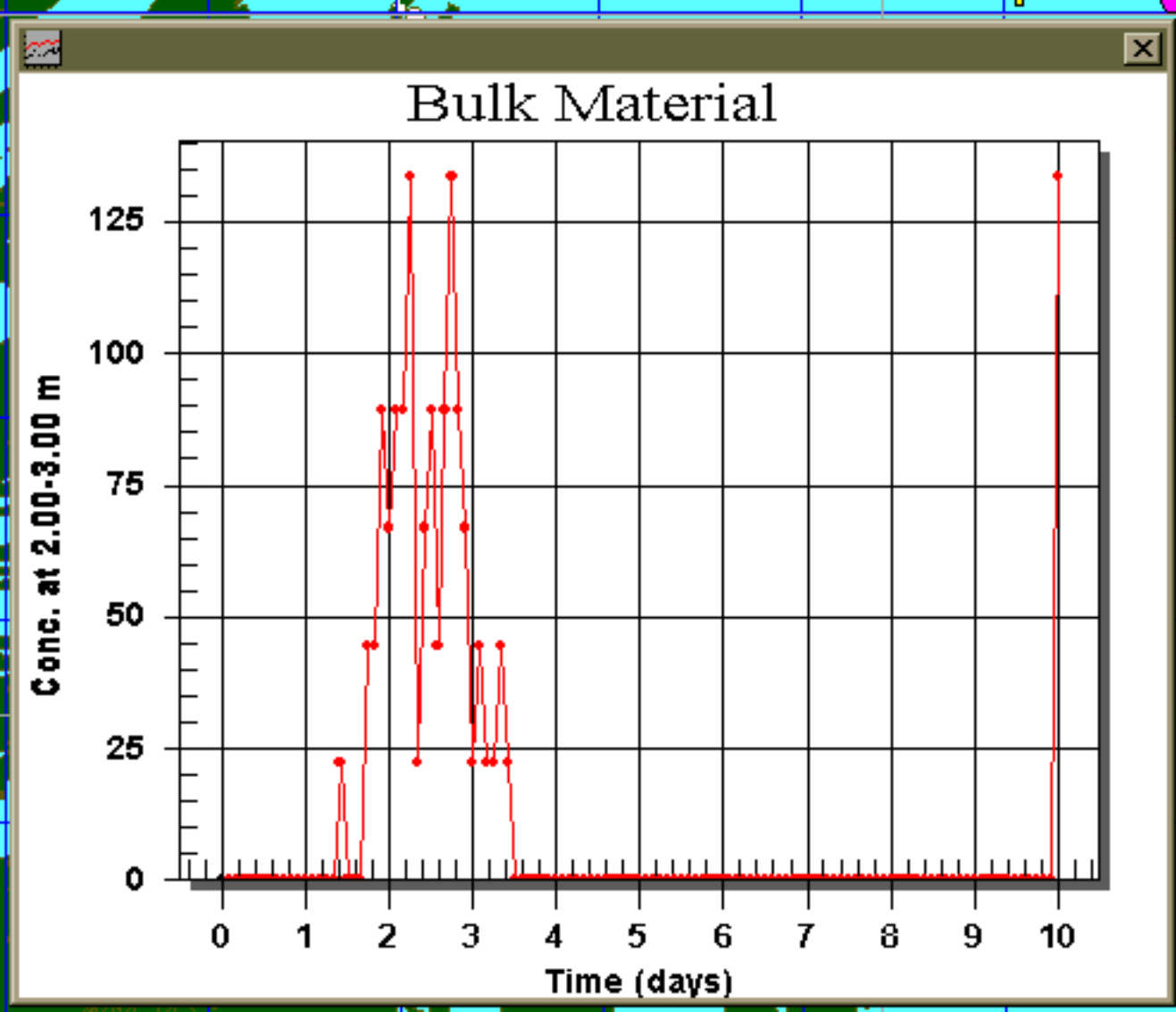
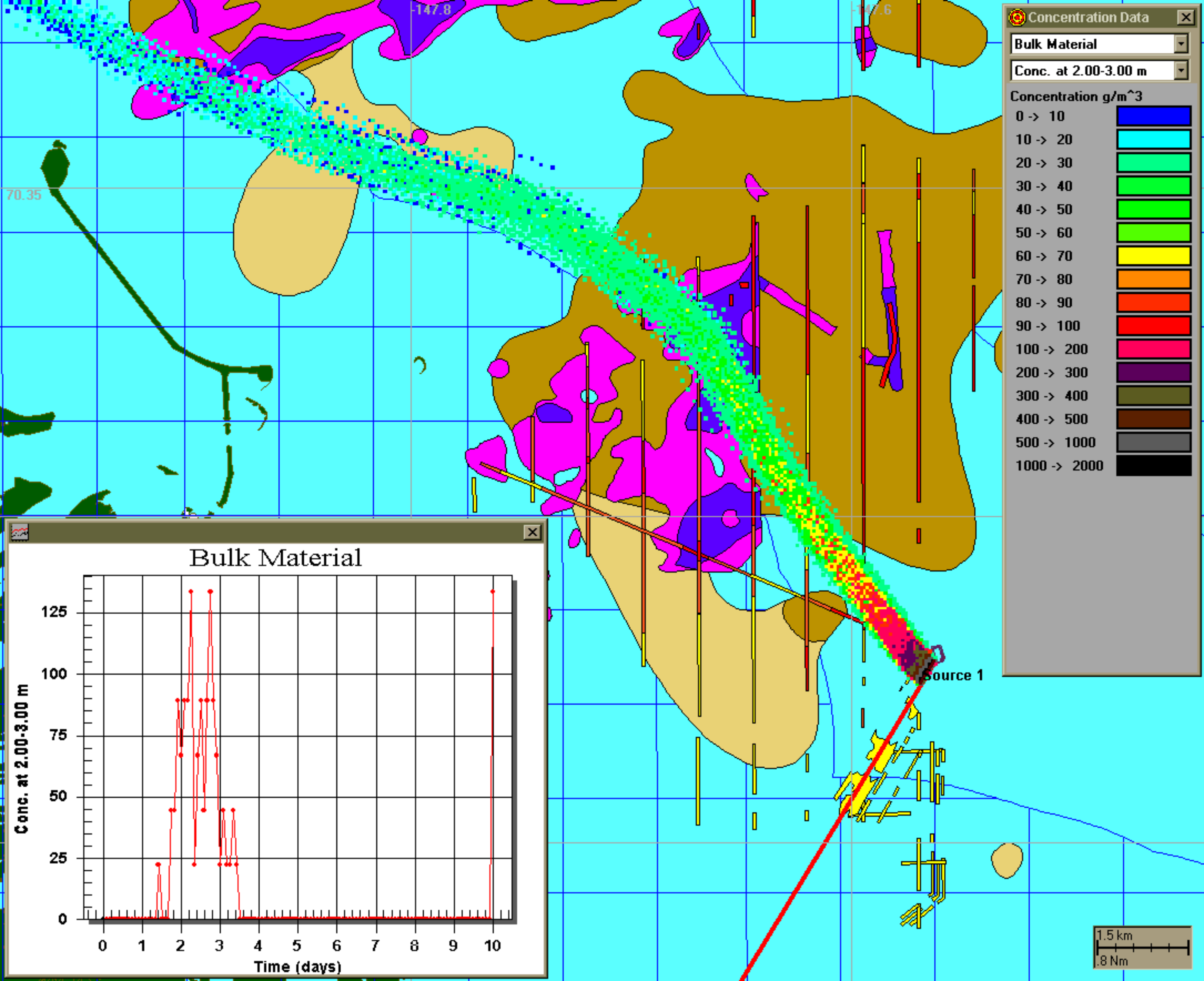

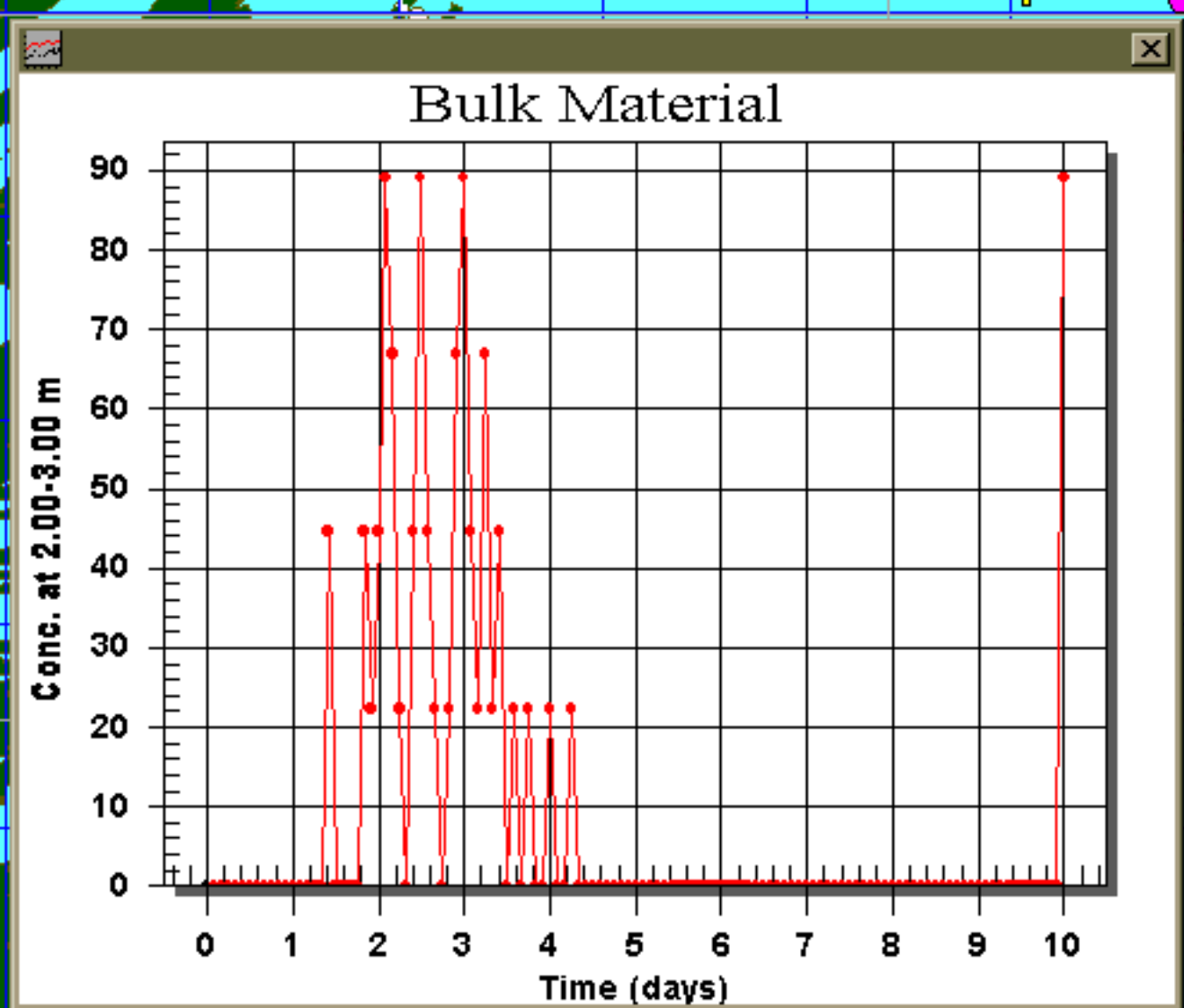
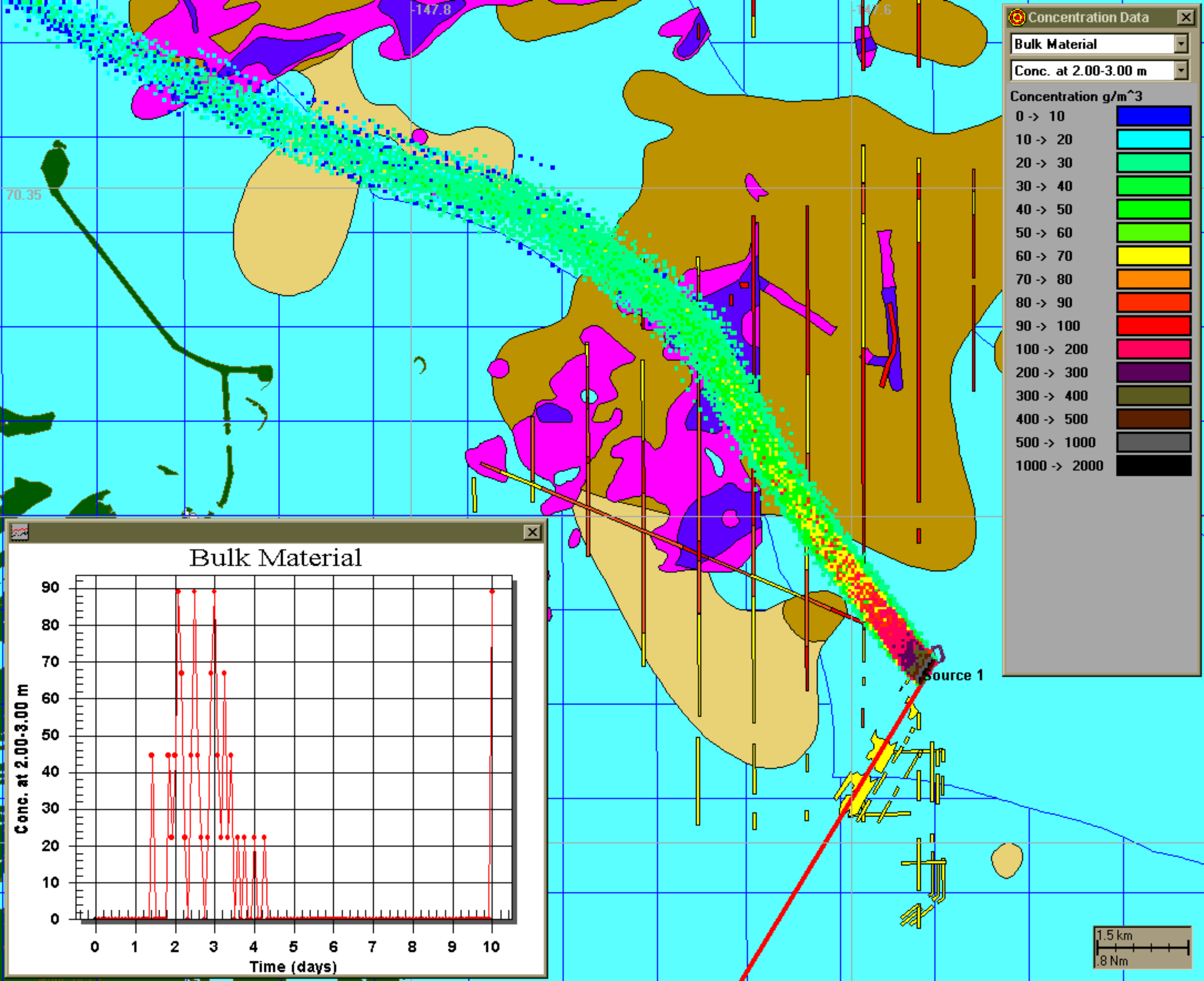

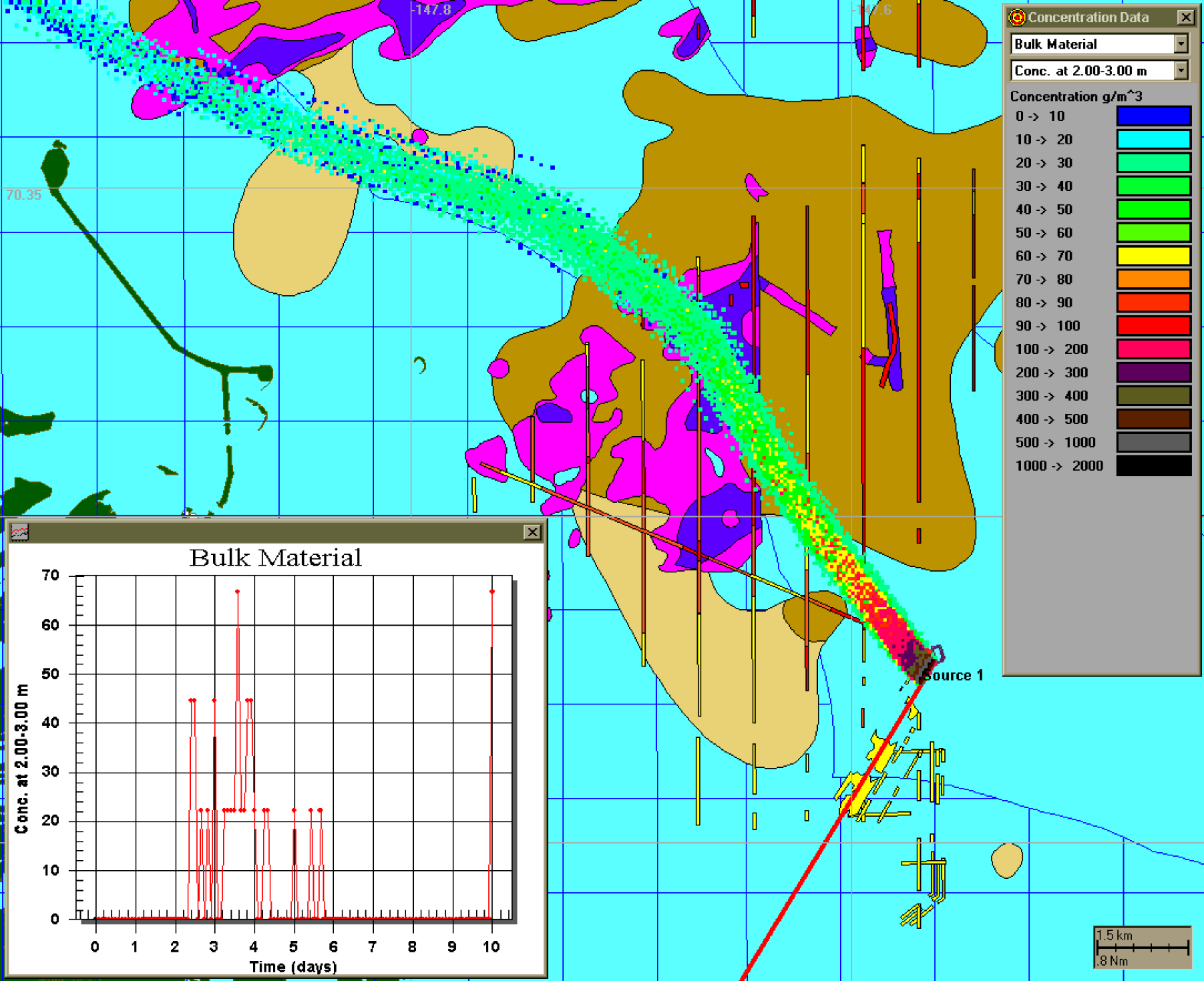

Concentration Data

Bulk Material

Conc. at 2.00-3.00 m

Concentration g/m^3

0 -> 10	Blue
10 -> 20	Cyan
20 -> 30	Green
30 -> 40	Light Green
40 -> 50	Yellow-Green
50 -> 60	Yellow
60 -> 70	Orange
70 -> 80	Red-Orange
80 -> 90	Red
90 -> 100	Magenta
100 -> 200	Dark Magenta
200 -> 300	Purple
300 -> 400	Brown
400 -> 500	Grey
500 -> 1000	Black
1000 -> 2000	Dark Grey

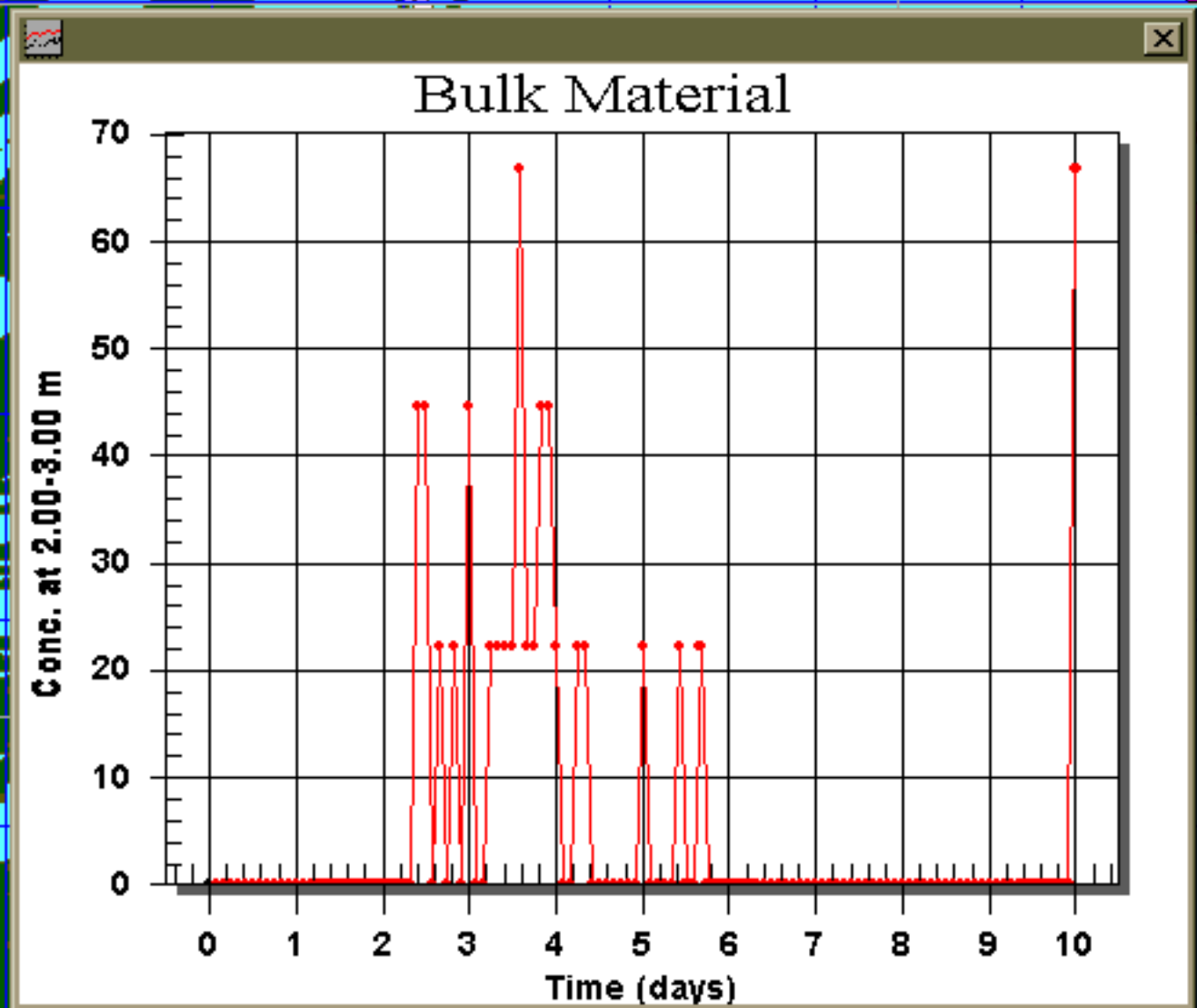

1.5 km
0.8 Nm

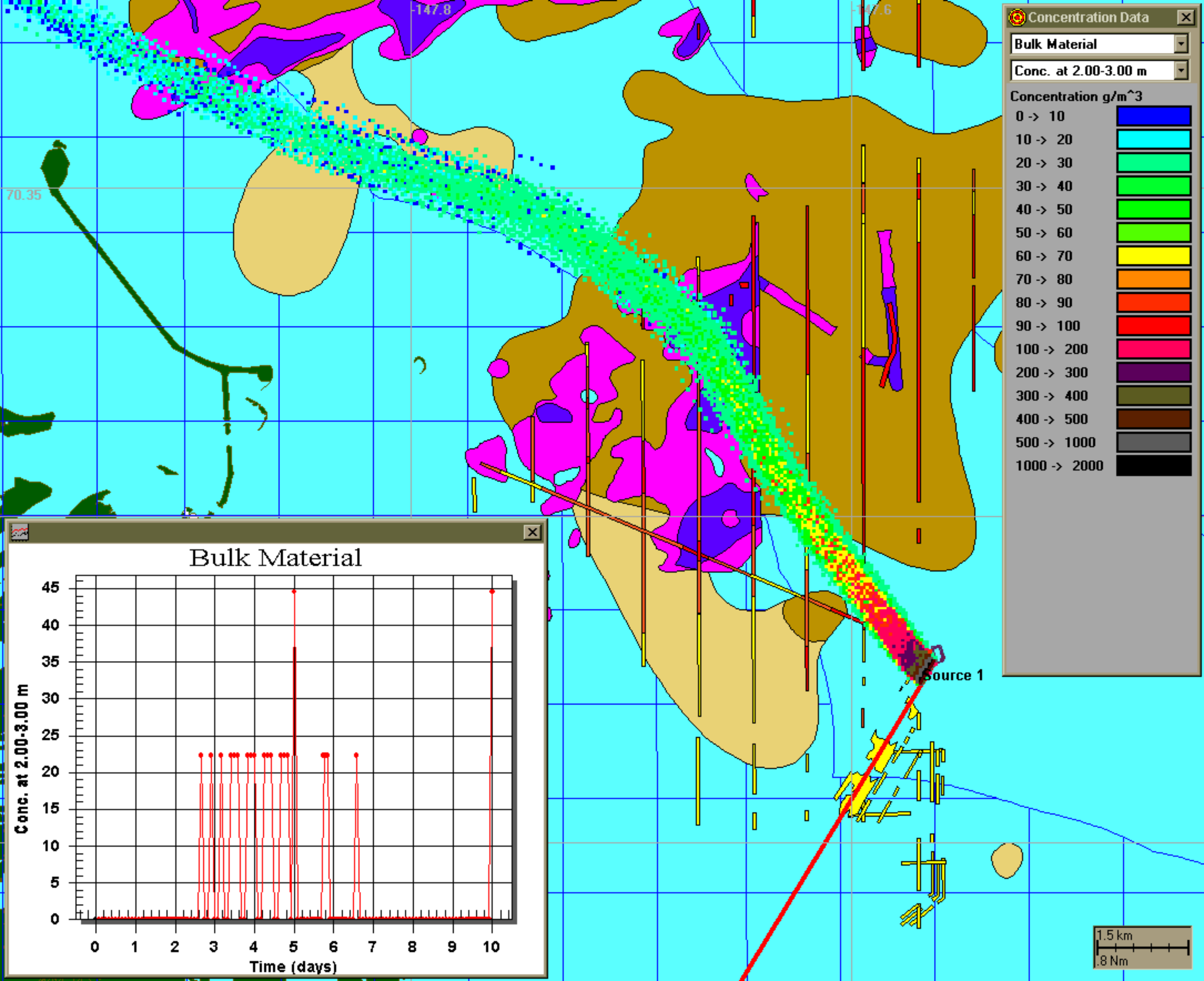

Concentration Data

Bulk Material

Conc. at 2.00-3.00 m

Concentration g/m³

0 -> 10	Blue
10 -> 20	Cyan
20 -> 30	Light Green
30 -> 40	Green
40 -> 50	Bright Green
50 -> 60	Yellow-Green
60 -> 70	Yellow
70 -> 80	Orange
80 -> 90	Red-Orange
90 -> 100	Red
100 -> 200	Magenta
200 -> 300	Purple
300 -> 400	Olive
400 -> 500	Brown
500 -> 1000	Grey
1000 -> 2000	Black

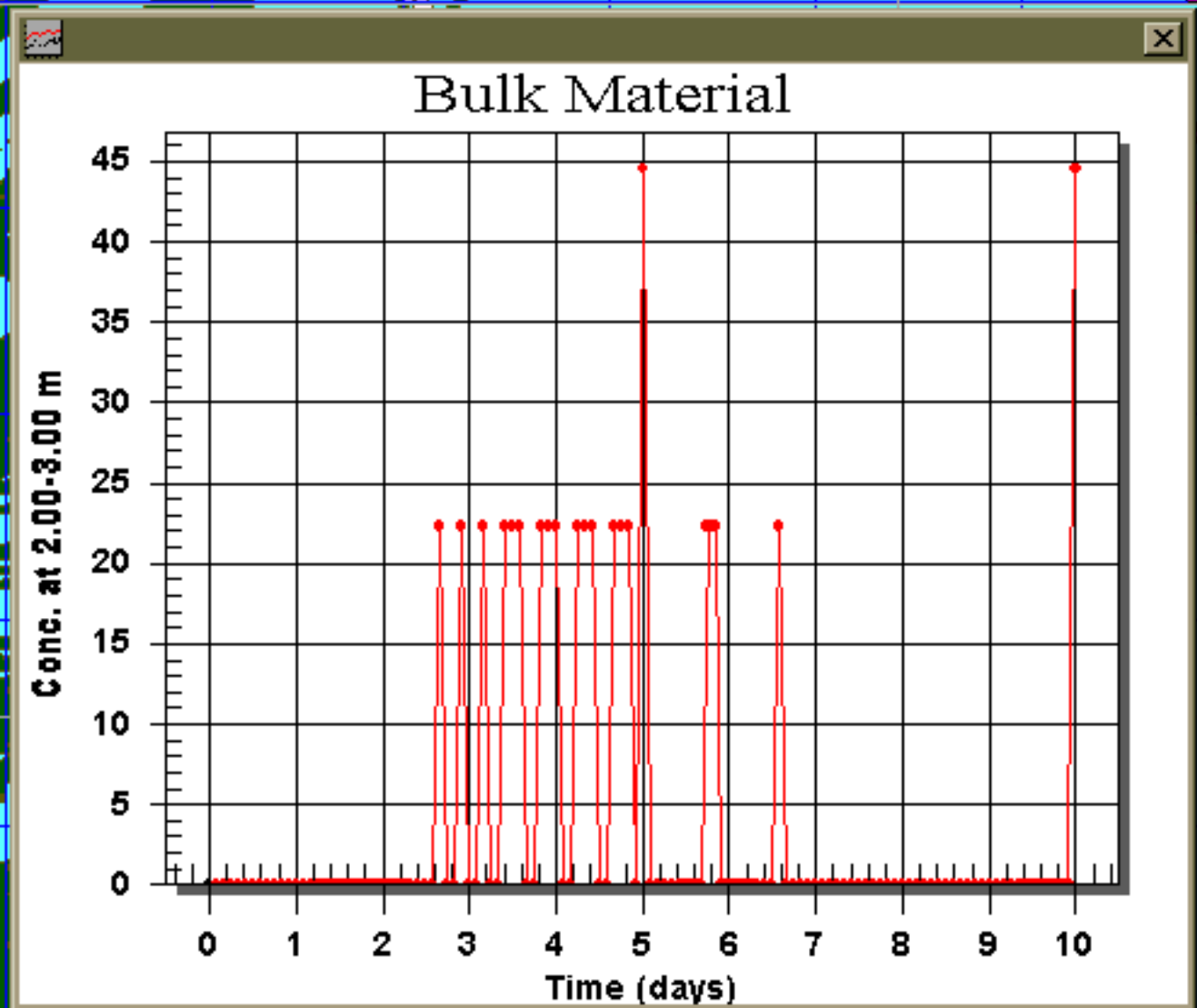

1.5 km
.8 Nm

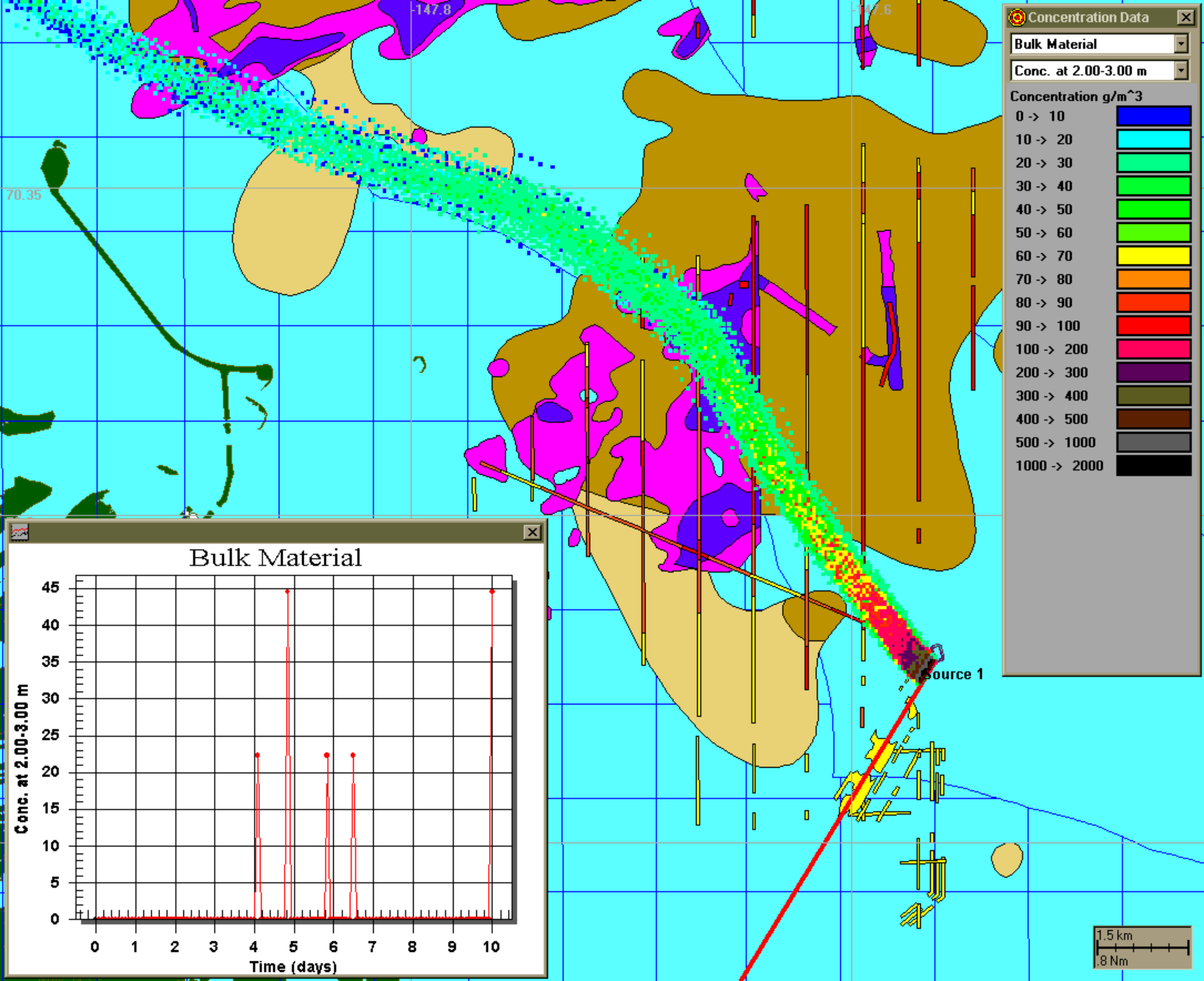

Concentration Data

Bulk Material

Conc. at 2.00-3.00 m

Concentration g/m³

0 -> 10	Blue
10 -> 20	Cyan
20 -> 30	Light Green
30 -> 40	Green
40 -> 50	Bright Green
50 -> 60	Yellow-Green
60 -> 70	Yellow
70 -> 80	Orange
80 -> 90	Red-Orange
90 -> 100	Red
100 -> 200	Magenta
200 -> 300	Purple
300 -> 400	Olive
400 -> 500	Brown
500 -> 1000	Grey
1000 -> 2000	Black

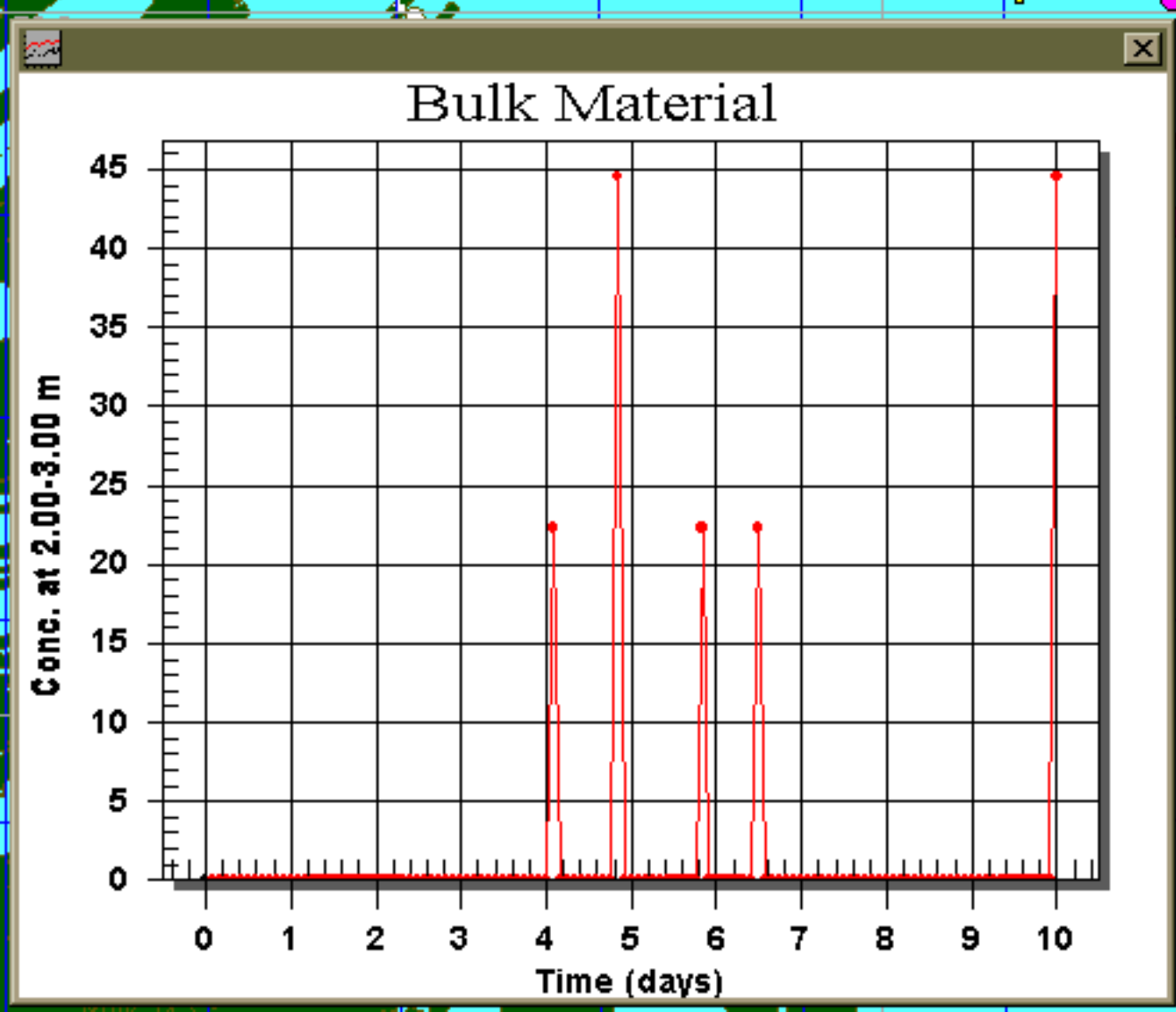

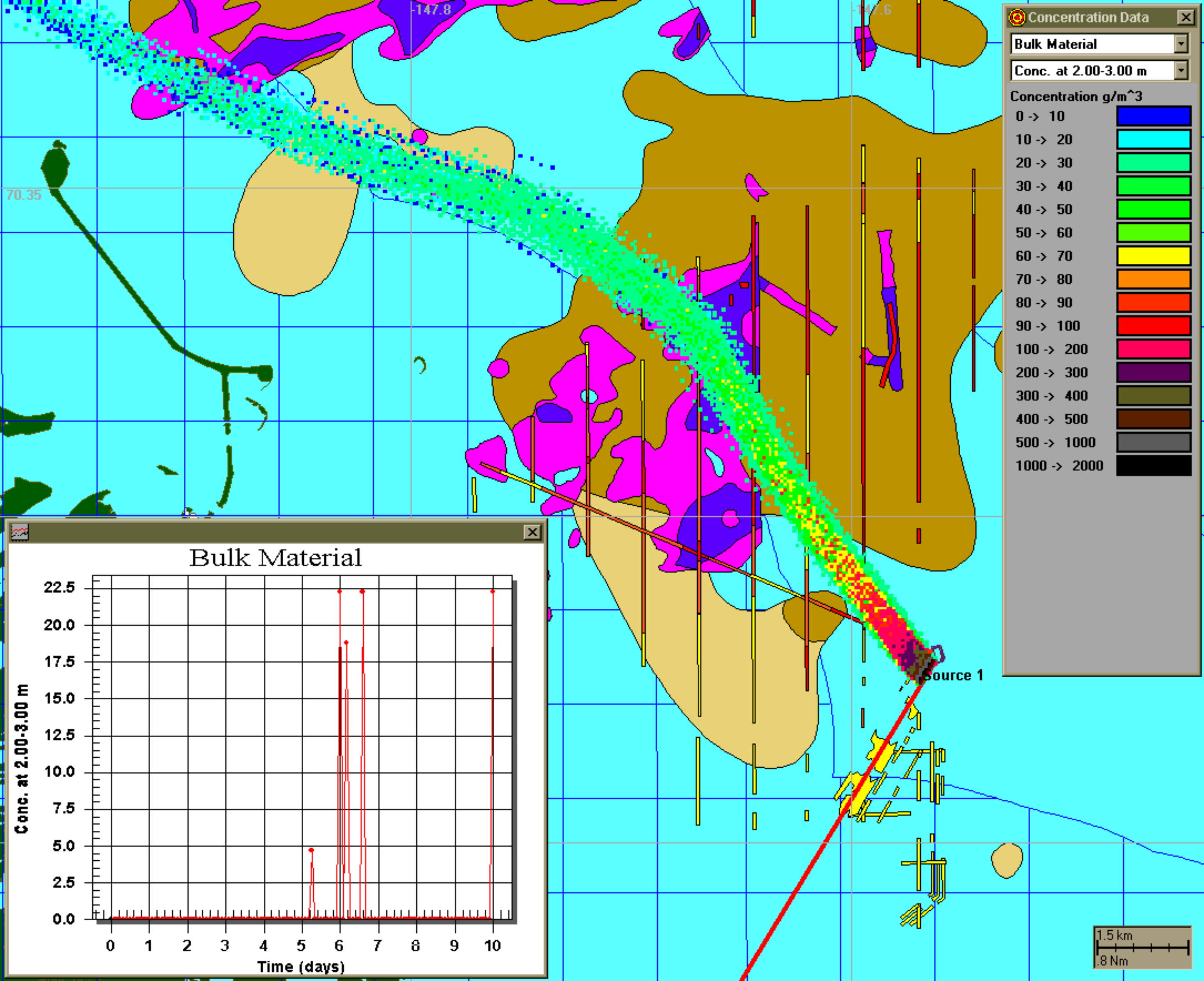

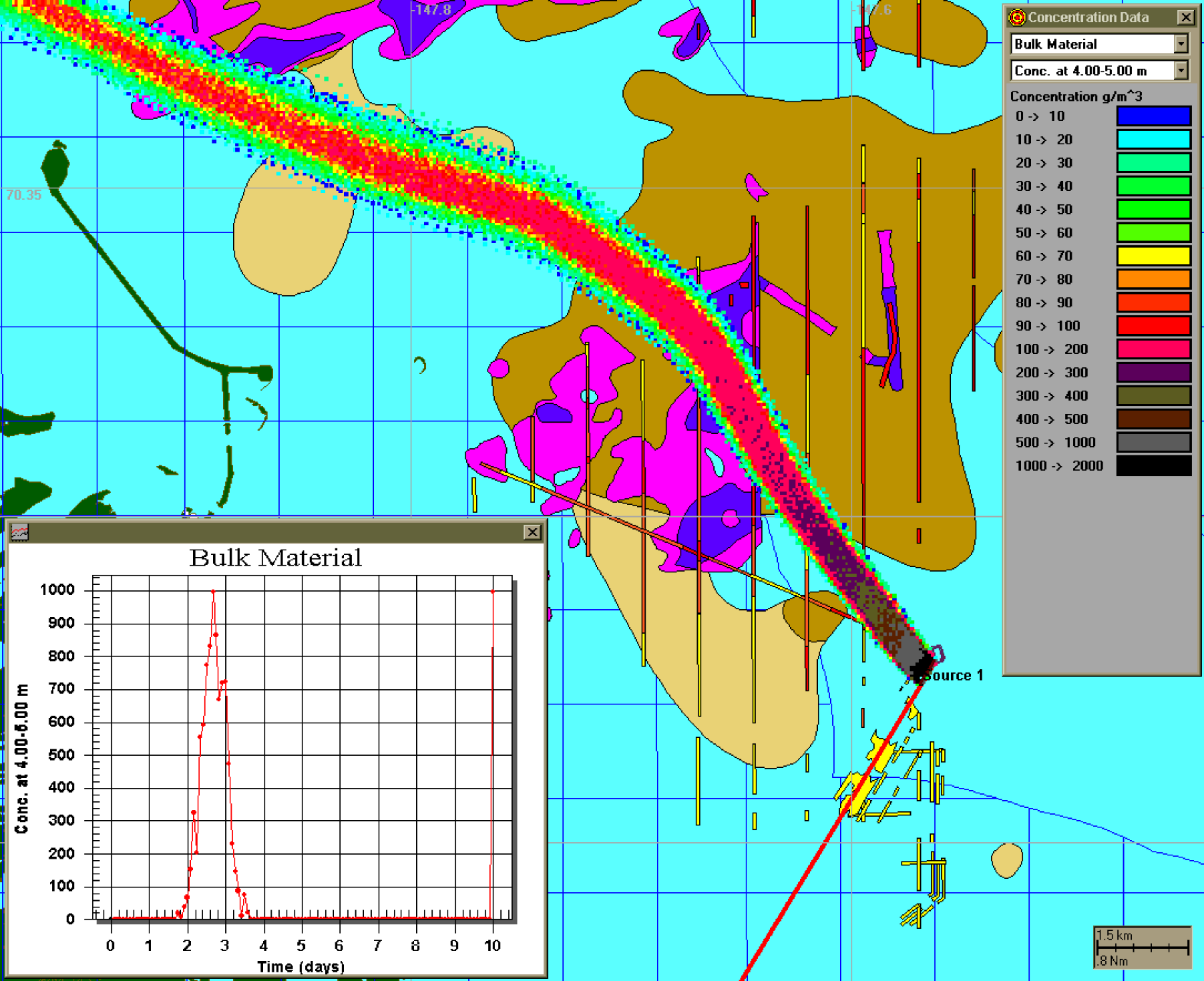

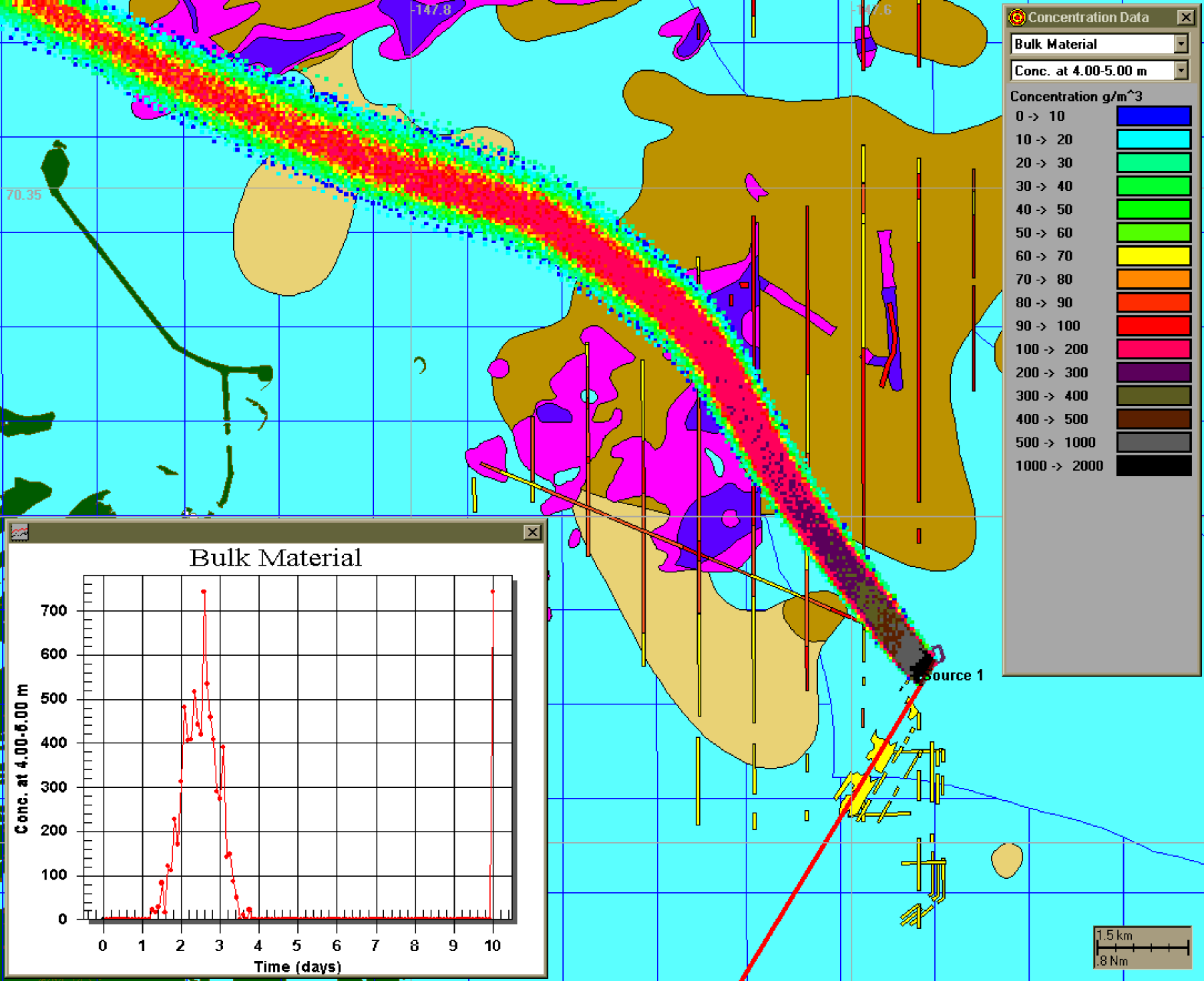

Concentration Data

Bulk Material

Conc. at 4.00-5.00 m

Concentration g/m³

0 -> 10	Blue
10 -> 20	Cyan
20 -> 30	Light Green
30 -> 40	Green
40 -> 50	Bright Green
50 -> 60	Yellow-Green
60 -> 70	Yellow
70 -> 80	Orange
80 -> 90	Red-Orange
90 -> 100	Red
100 -> 200	Magenta
200 -> 300	Purple
300 -> 400	Olive
400 -> 500	Brown
500 -> 1000	Grey
1000 -> 2000	Black

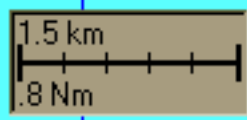
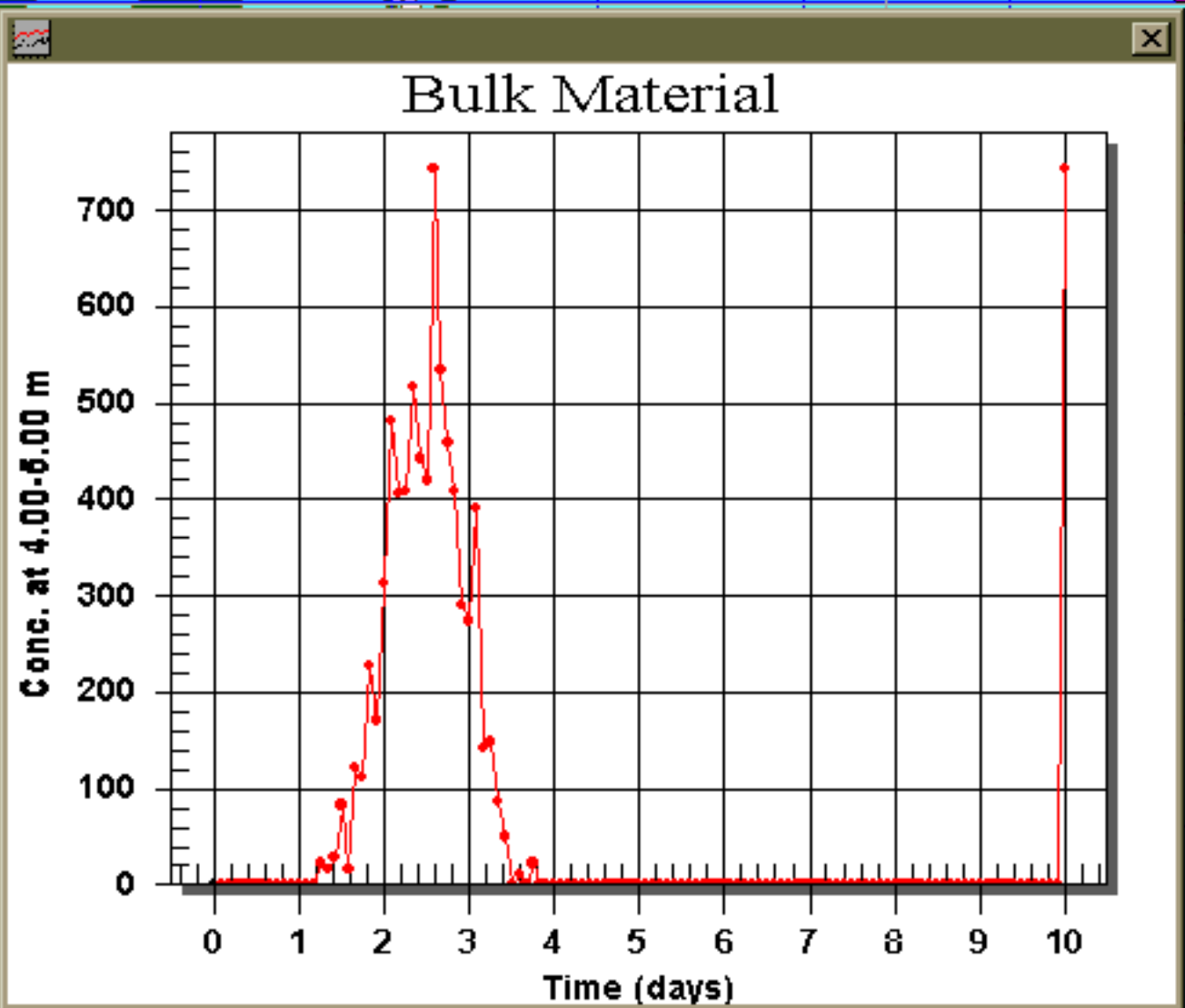

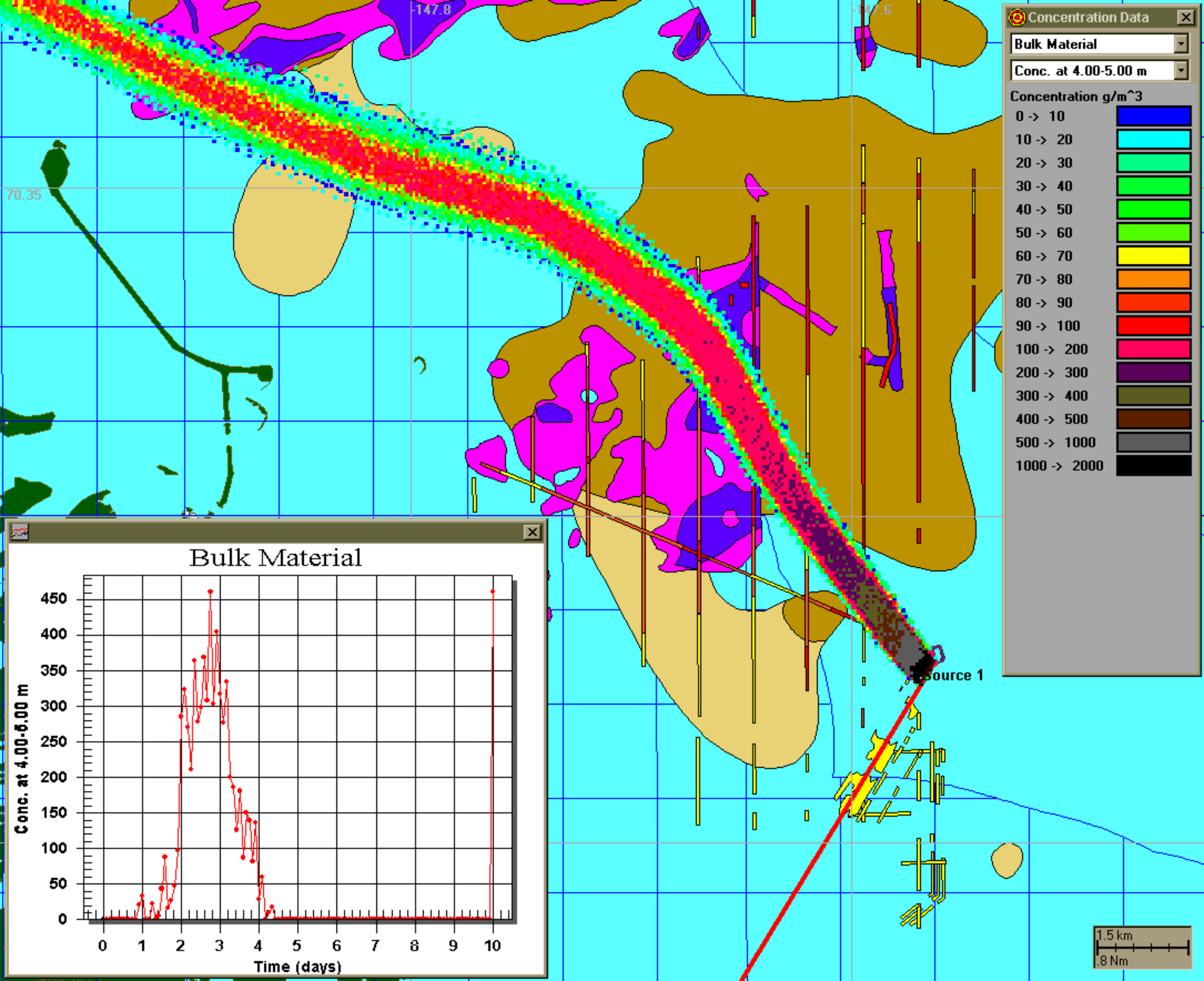

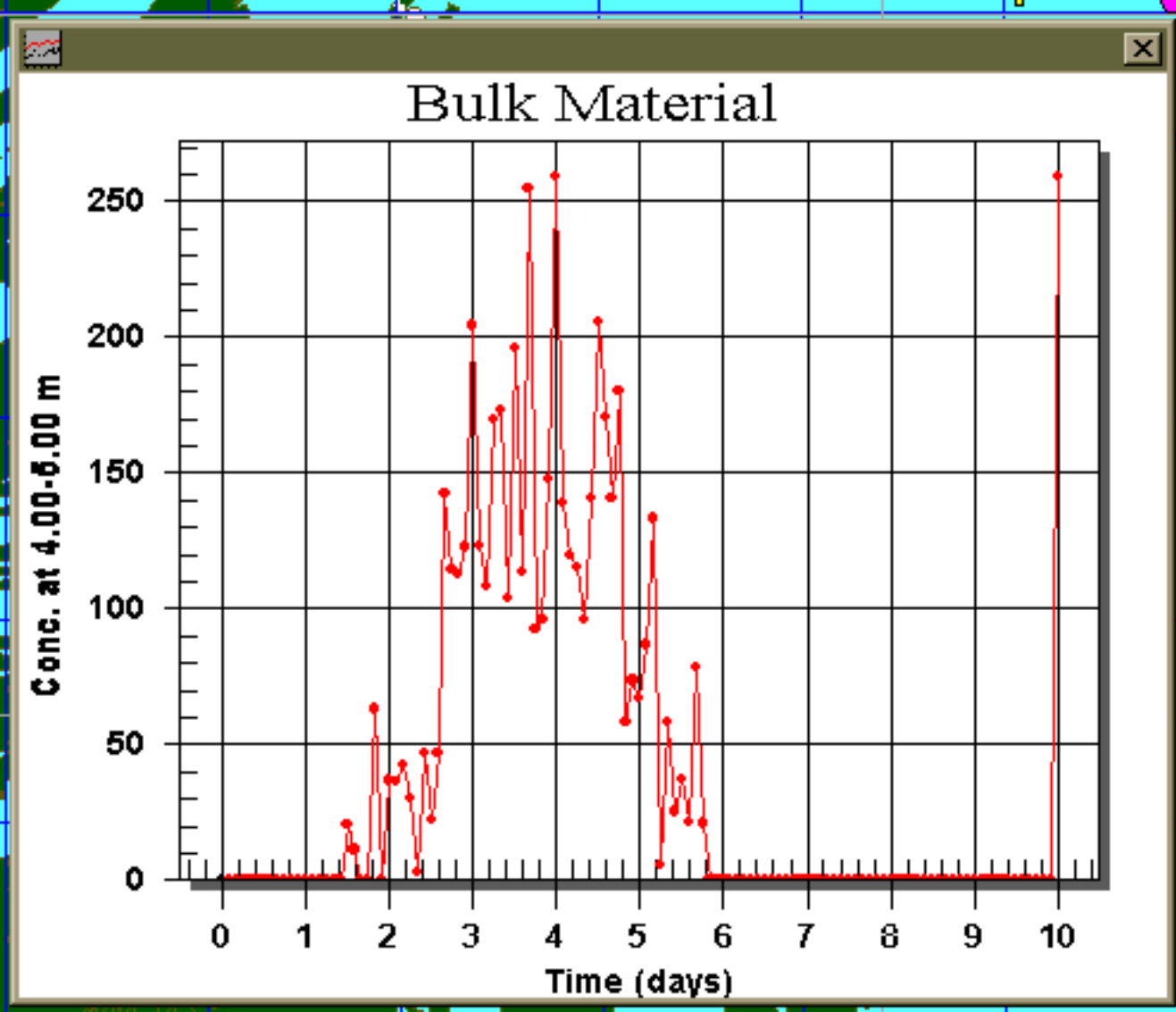
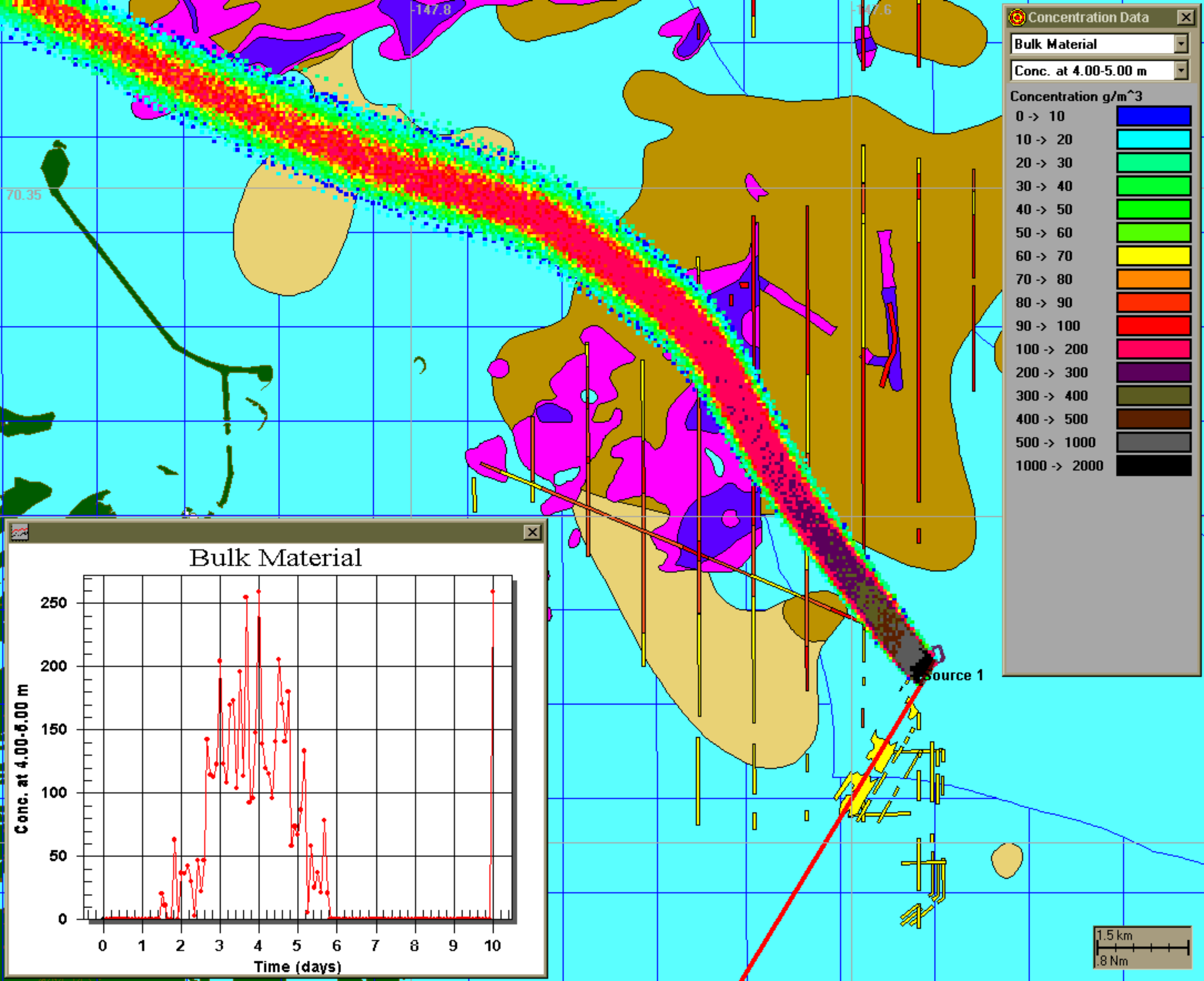

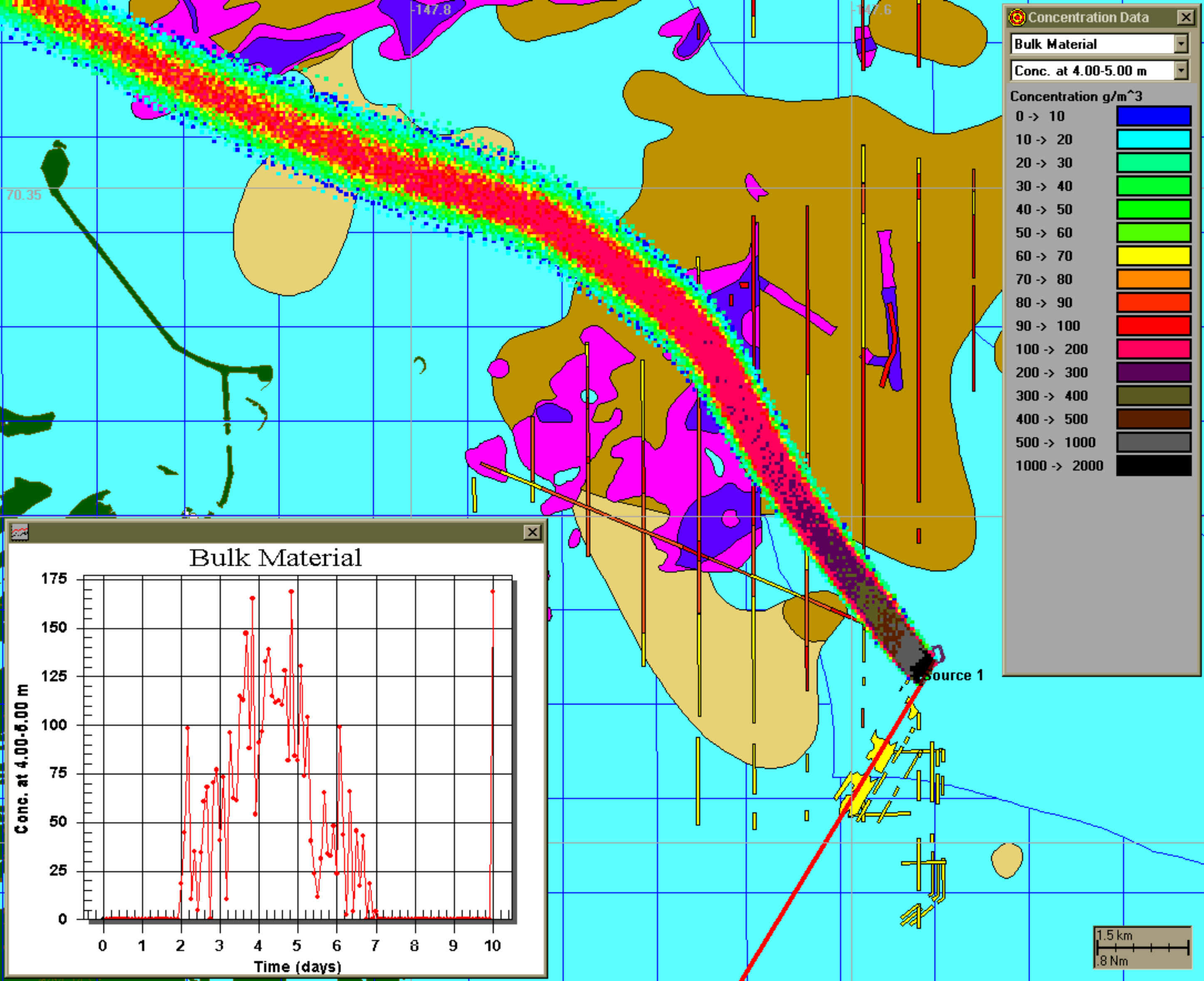

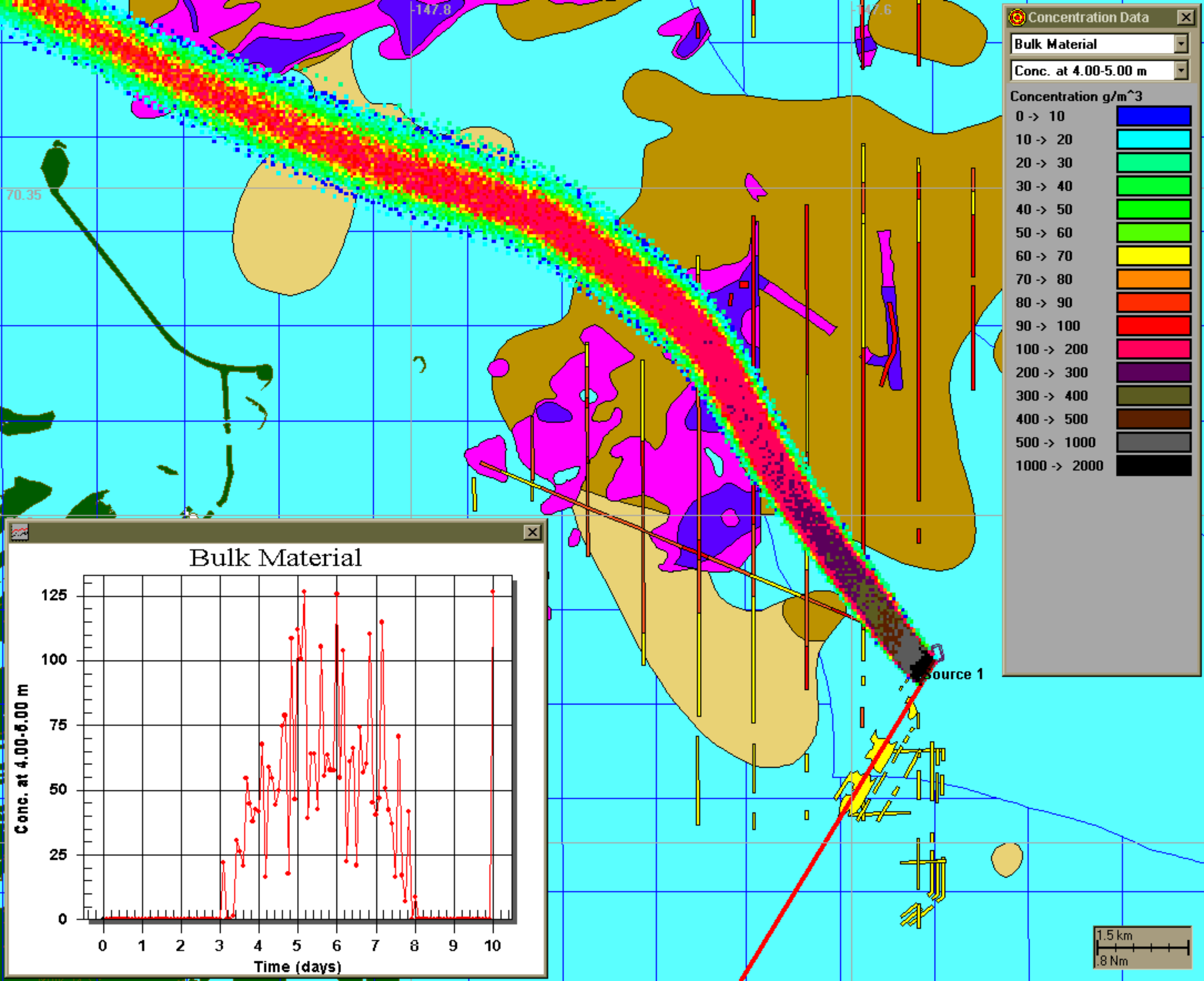

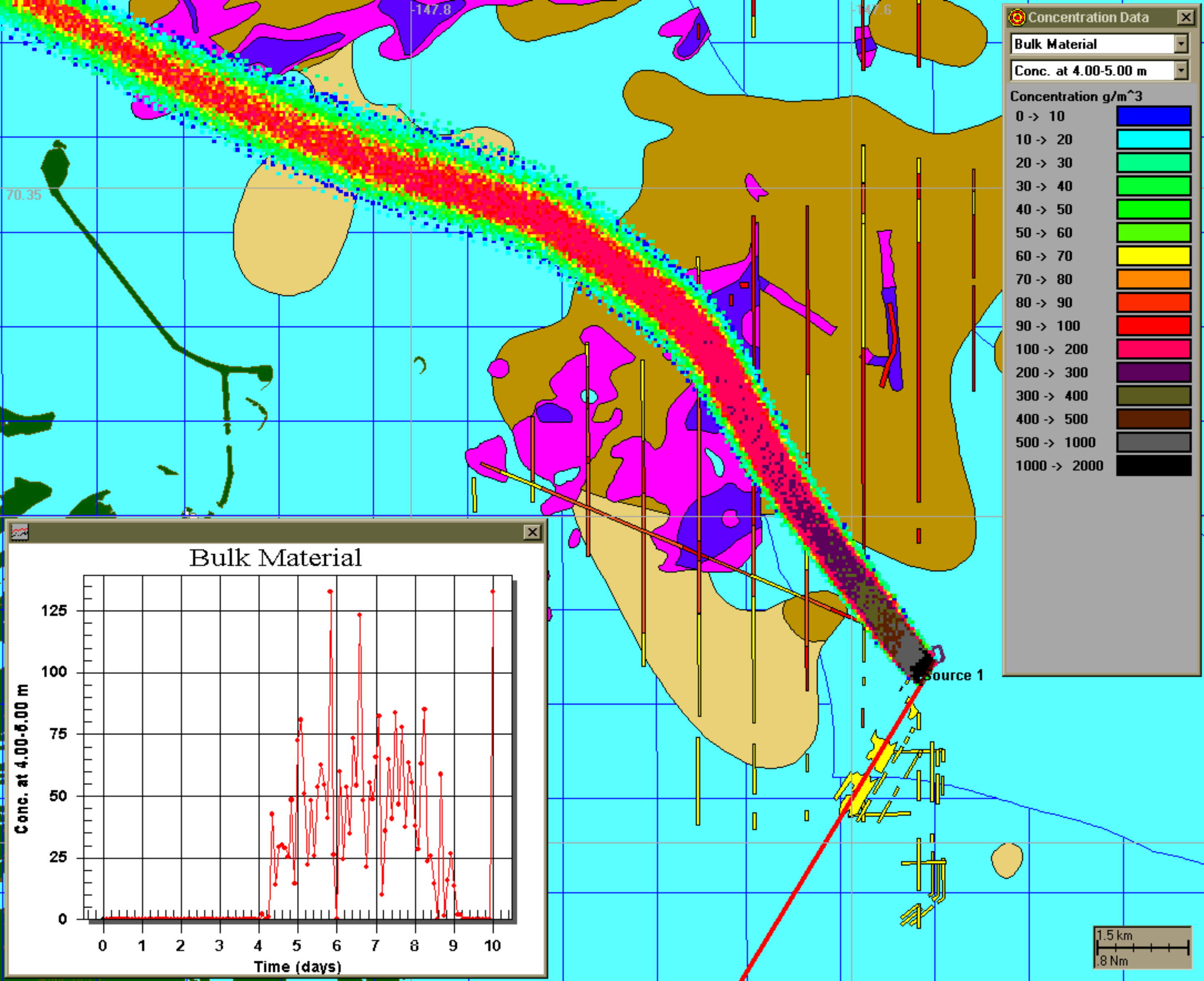

Concentration Data

Bulk Material

Conc. at 4.00-5.00 m

Concentration g/m^3

- 0 -> 10
- 10 -> 20
- 20 -> 30
- 30 -> 40
- 40 -> 50
- 50 -> 60
- 60 -> 70
- 70 -> 80
- 80 -> 90
- 90 -> 100
- 100 -> 200
- 200 -> 300
- 300 -> 400
- 400 -> 500
- 500 -> 1000
- 1000 -> 2000

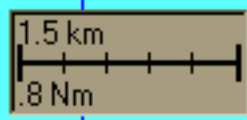
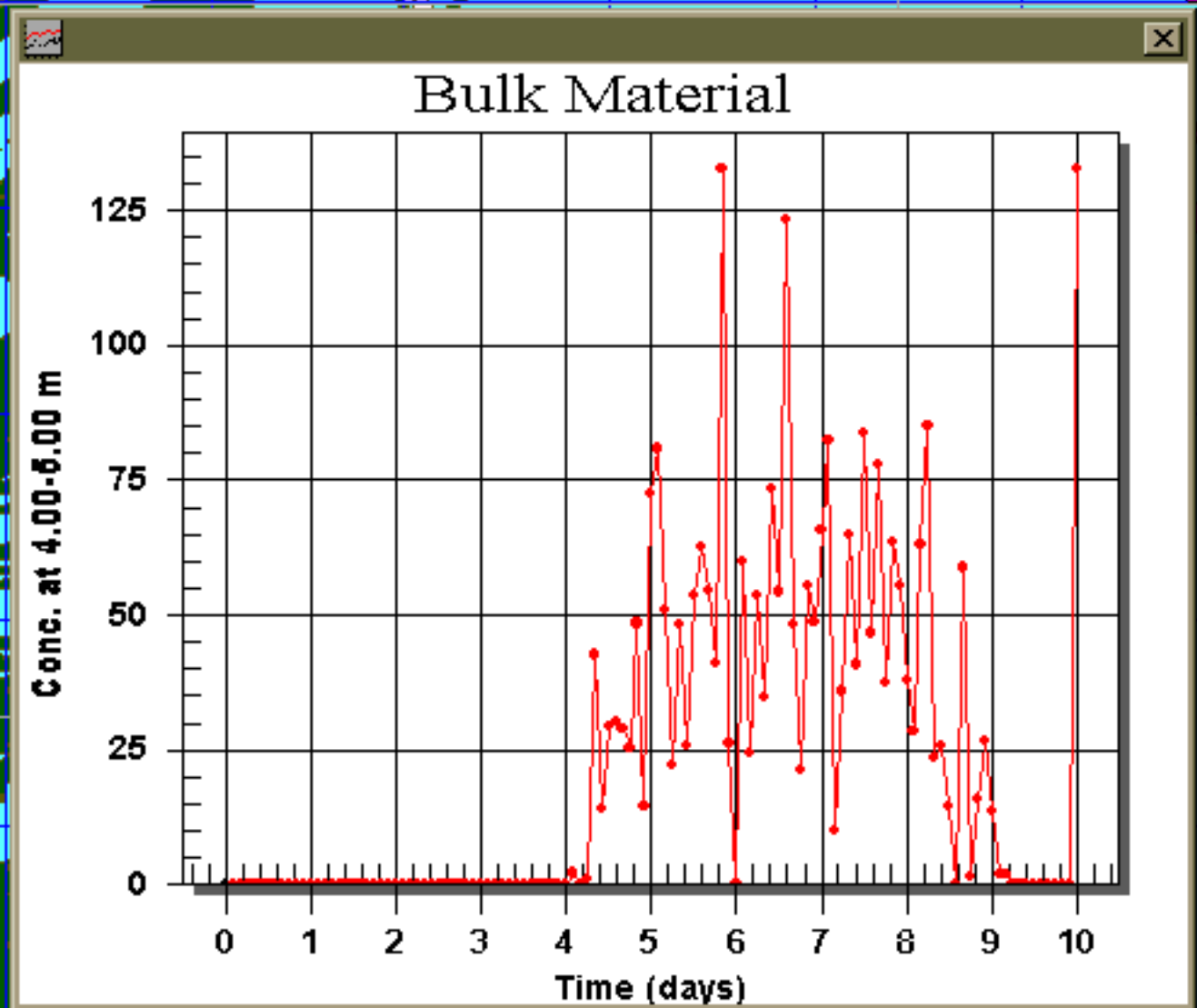

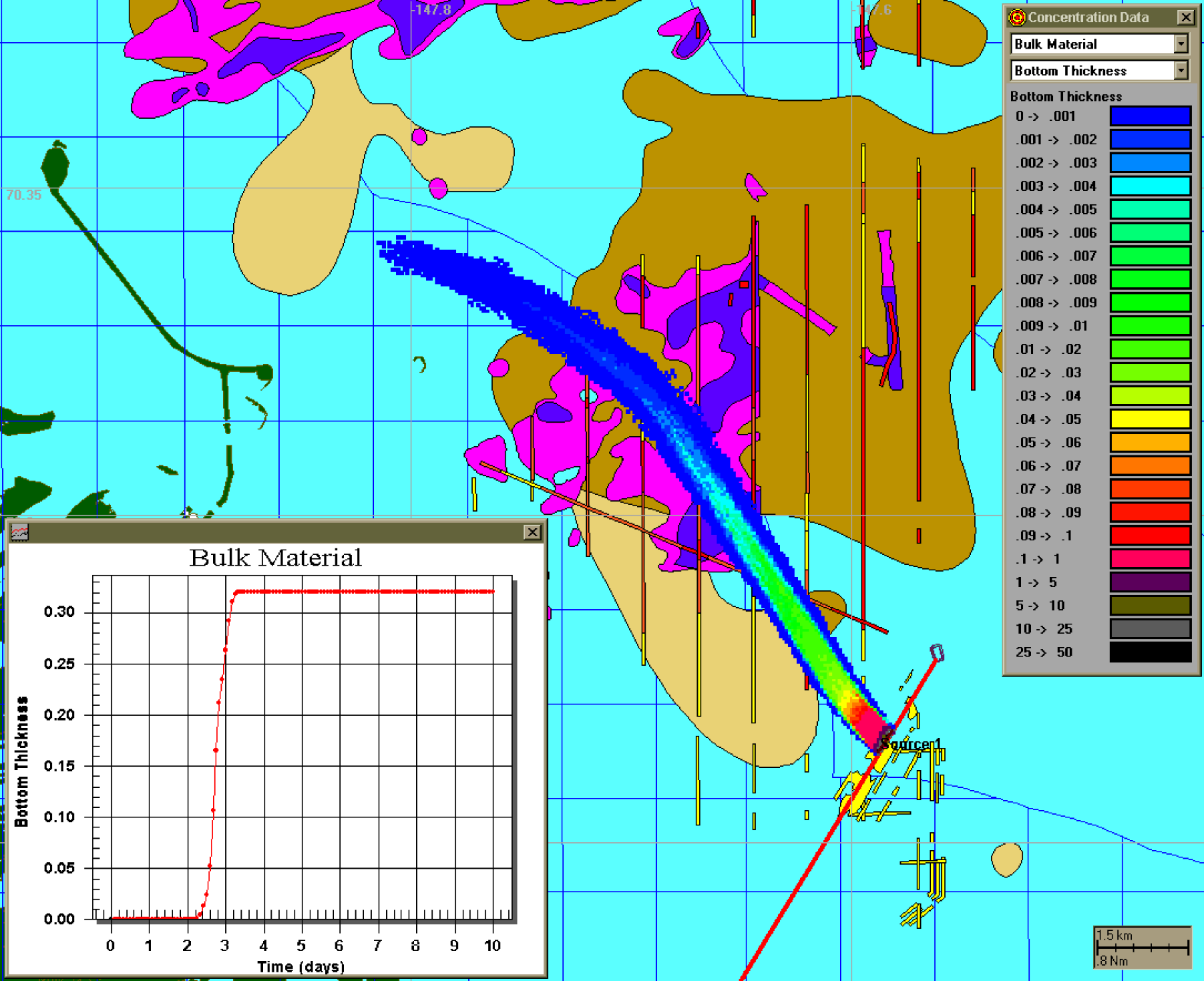

Concentration Data

Bulk Material

Bottom Thickness

Bottom Thickness

- 0 -> .001
- .001 -> .002
- .002 -> .003
- .003 -> .004
- .004 -> .005
- .005 -> .006
- .006 -> .007
- .007 -> .008
- .008 -> .009
- .009 -> .01
- .01 -> .02
- .02 -> .03
- .03 -> .04
- .04 -> .05
- .05 -> .06
- .06 -> .07
- .07 -> .08
- .08 -> .09
- .09 -> .1
- .1 -> 1
- 1 -> 5
- 5 -> 10
- 10 -> 25
- 25 -> 50

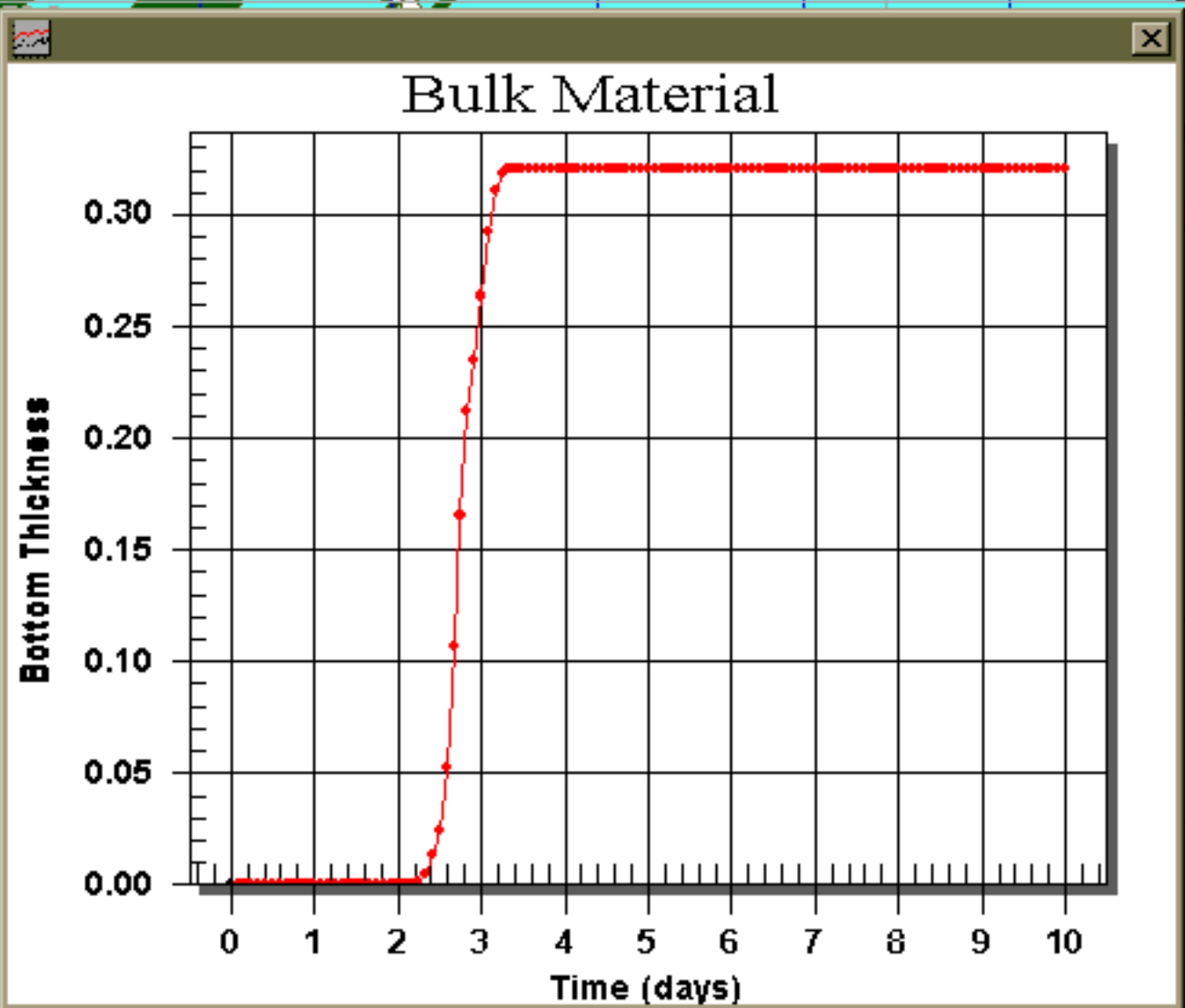

1.5 km
0.8 Nm

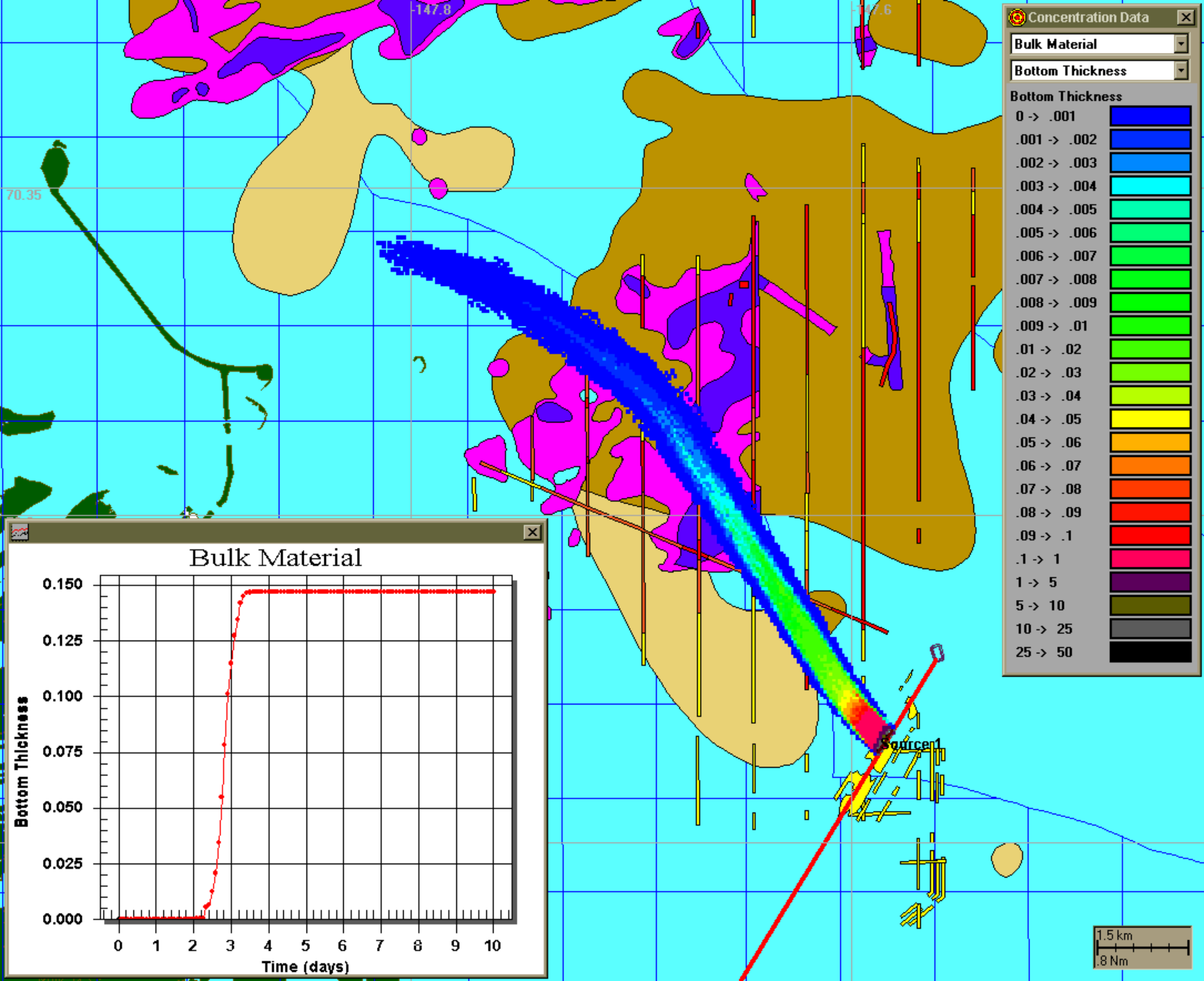

Concentration Data

Bulk Material

Bottom Thickness

Bottom Thickness

0 -> .001	[Dark Blue]
.001 -> .002	[Blue]
.002 -> .003	[Light Blue]
.003 -> .004	[Cyan]
.004 -> .005	[Green-Cyan]
.005 -> .006	[Green]
.006 -> .007	[Light Green]
.007 -> .008	[Green]
.008 -> .009	[Light Green]
.009 -> .01	[Green]
.01 -> .02	[Light Green]
.02 -> .03	[Yellow-Green]
.03 -> .04	[Yellow]
.04 -> .05	[Light Yellow]
.05 -> .06	[Orange]
.06 -> .07	[Red-Orange]
.07 -> .08	[Red]
.08 -> .09	[Dark Red]
.09 -> .1	[Red]
.1 -> 1	[Magenta]
1 -> 5	[Purple]
5 -> 10	[Dark Purple]
10 -> 25	[Black-Gray]
25 -> 50	[Black]

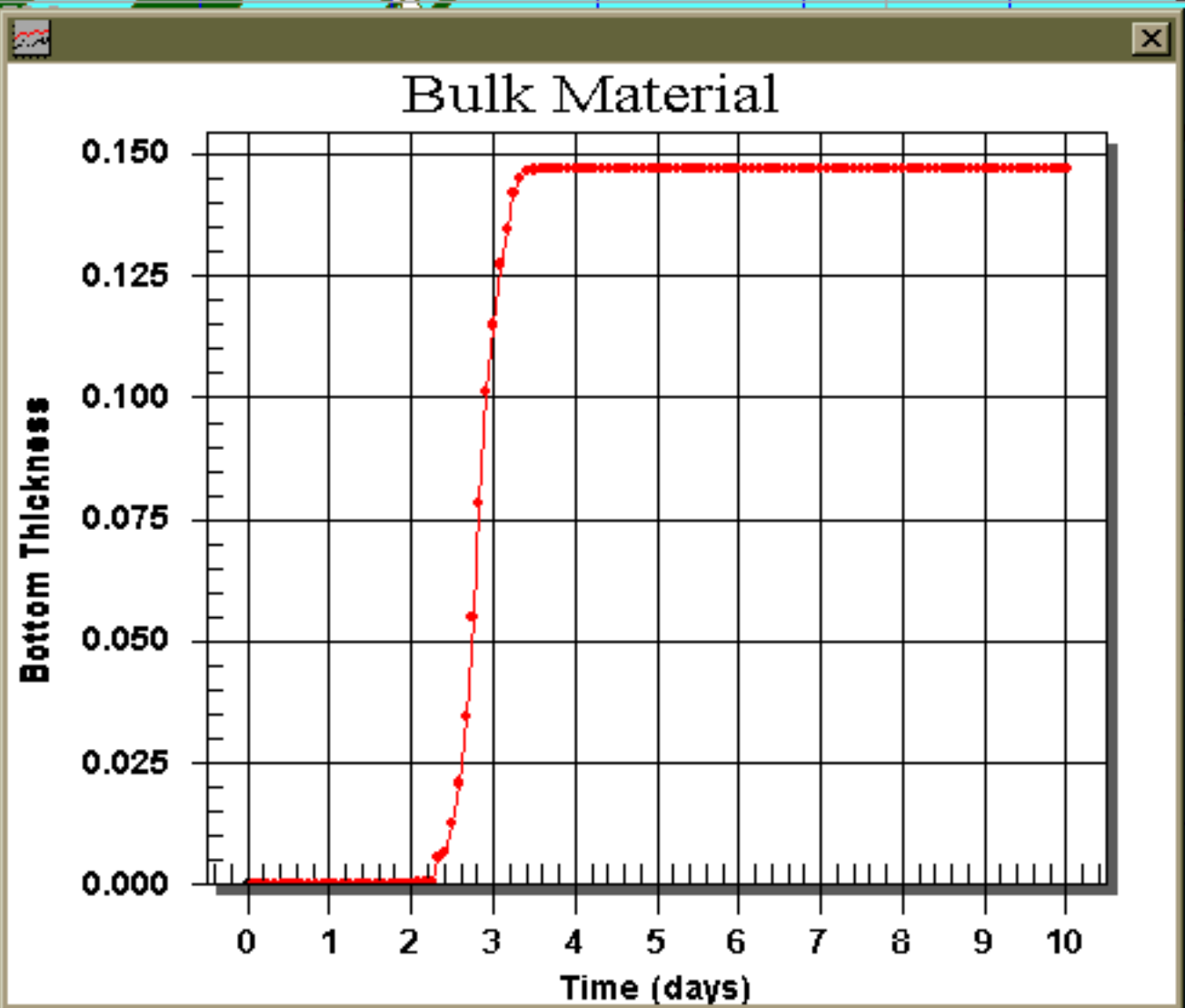

1.5 km
0.8 Nm

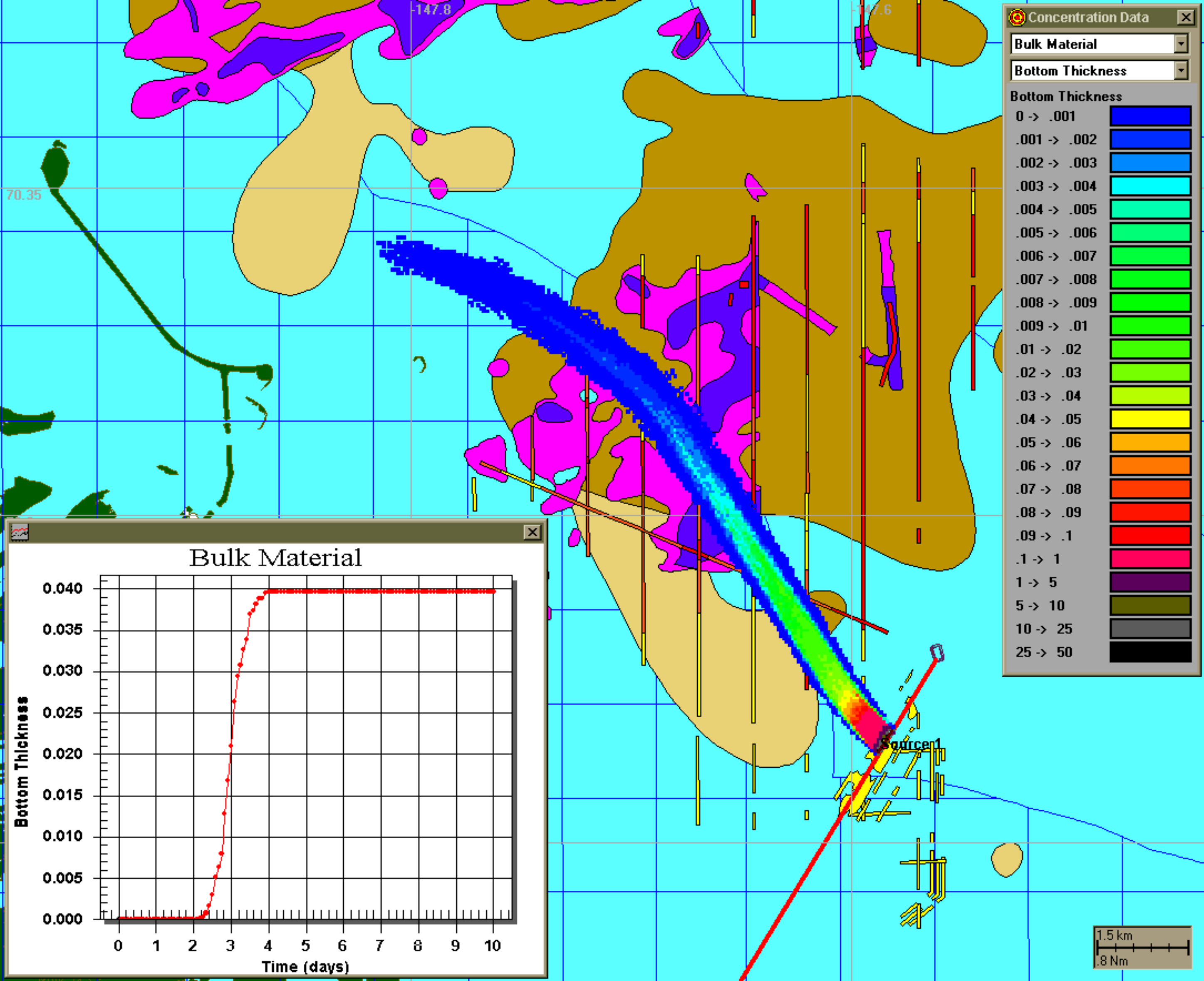

Concentration Data

Bulk Material

Bottom Thickness

Bottom Thickness

0 -> .001	[Dark Blue]
.001 -> .002	[Blue]
.002 -> .003	[Light Blue]
.003 -> .004	[Cyan]
.004 -> .005	[Green-Cyan]
.005 -> .006	[Green]
.006 -> .007	[Light Green]
.007 -> .008	[Green]
.008 -> .009	[Light Green]
.009 -> .01	[Green]
.01 -> .02	[Light Green]
.02 -> .03	[Yellow-Green]
.03 -> .04	[Yellow]
.04 -> .05	[Light Yellow]
.05 -> .06	[Orange]
.06 -> .07	[Red-Orange]
.07 -> .08	[Red]
.08 -> .09	[Dark Red]
.09 -> .1	[Red]
.1 -> 1	[Pink]
1 -> 5	[Purple]
5 -> 10	[Dark Purple]
10 -> 25	[Grey]
25 -> 50	[Black]

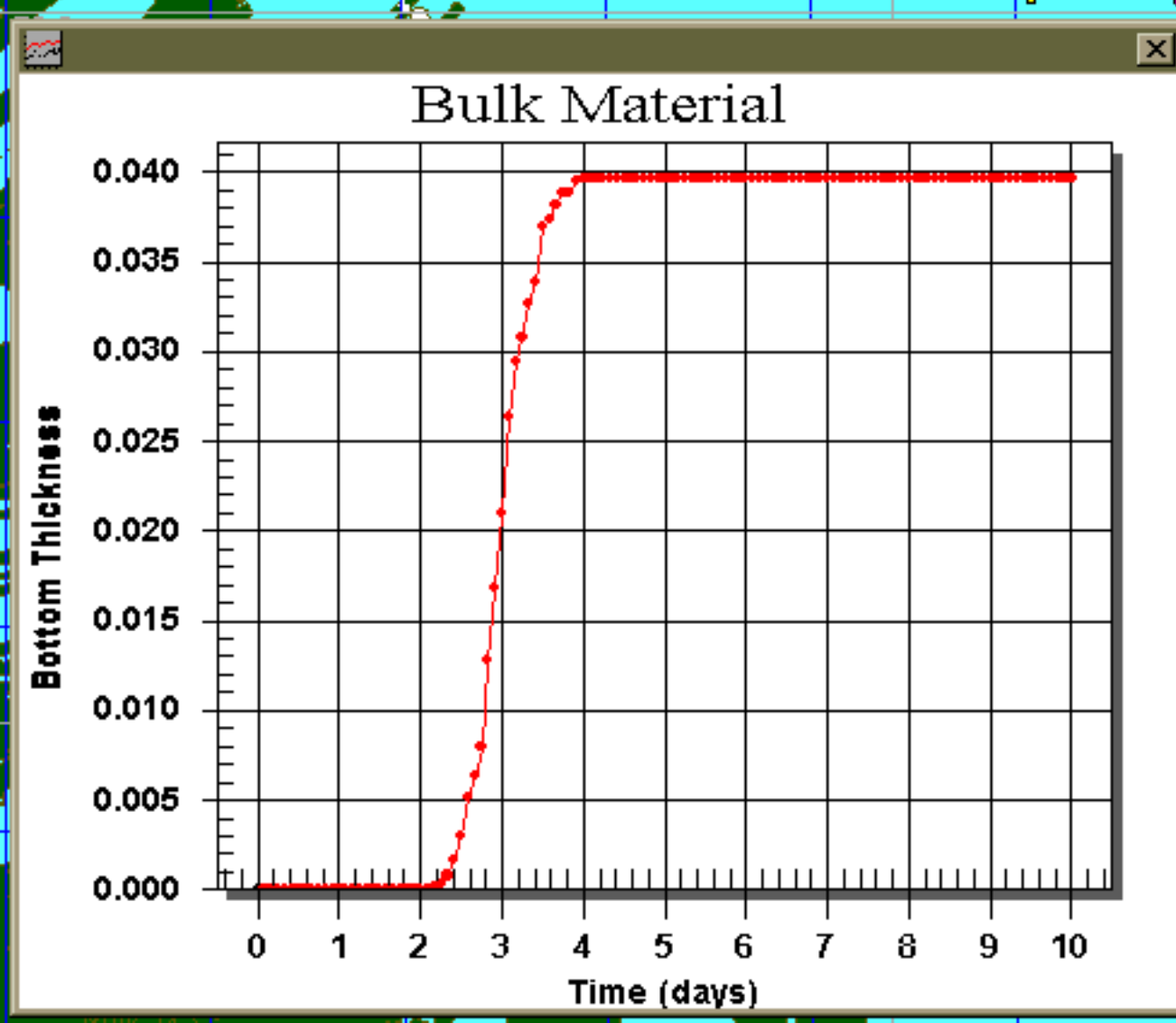

1.5 km
.8 Nm

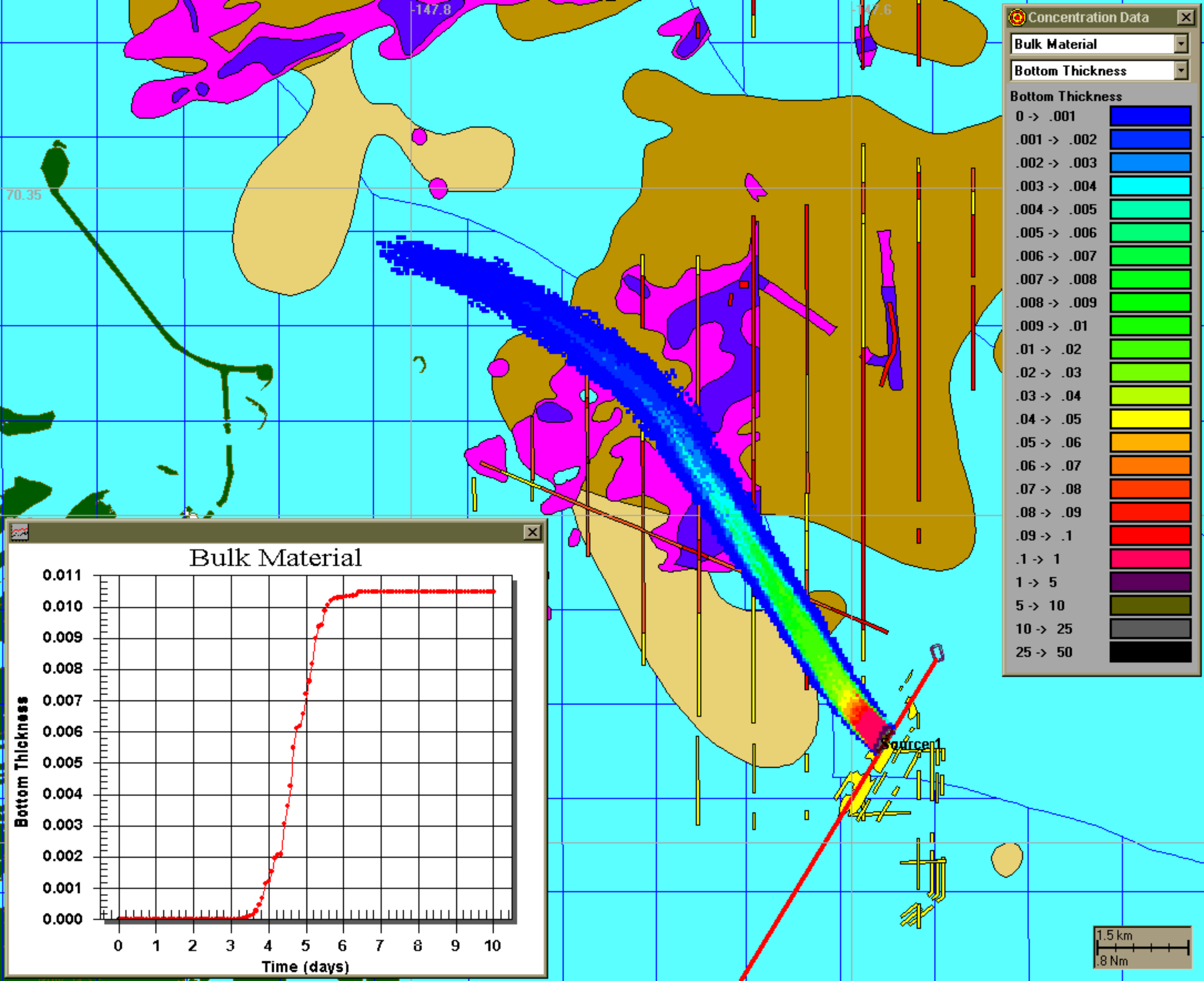

70.35

-147.8

-147.6

Source 1

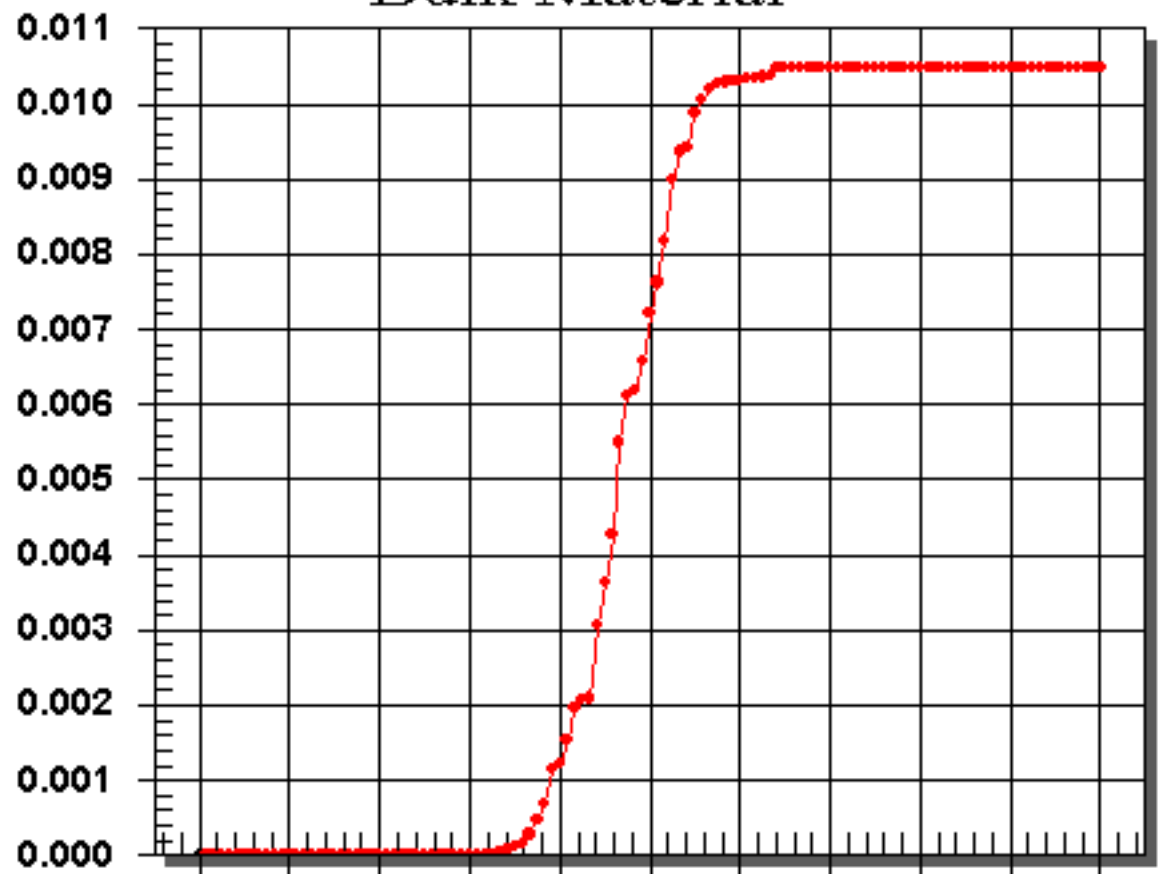

Bulk Material

Bottom Thickness

Time (days)

1.5 km
.8 Nm

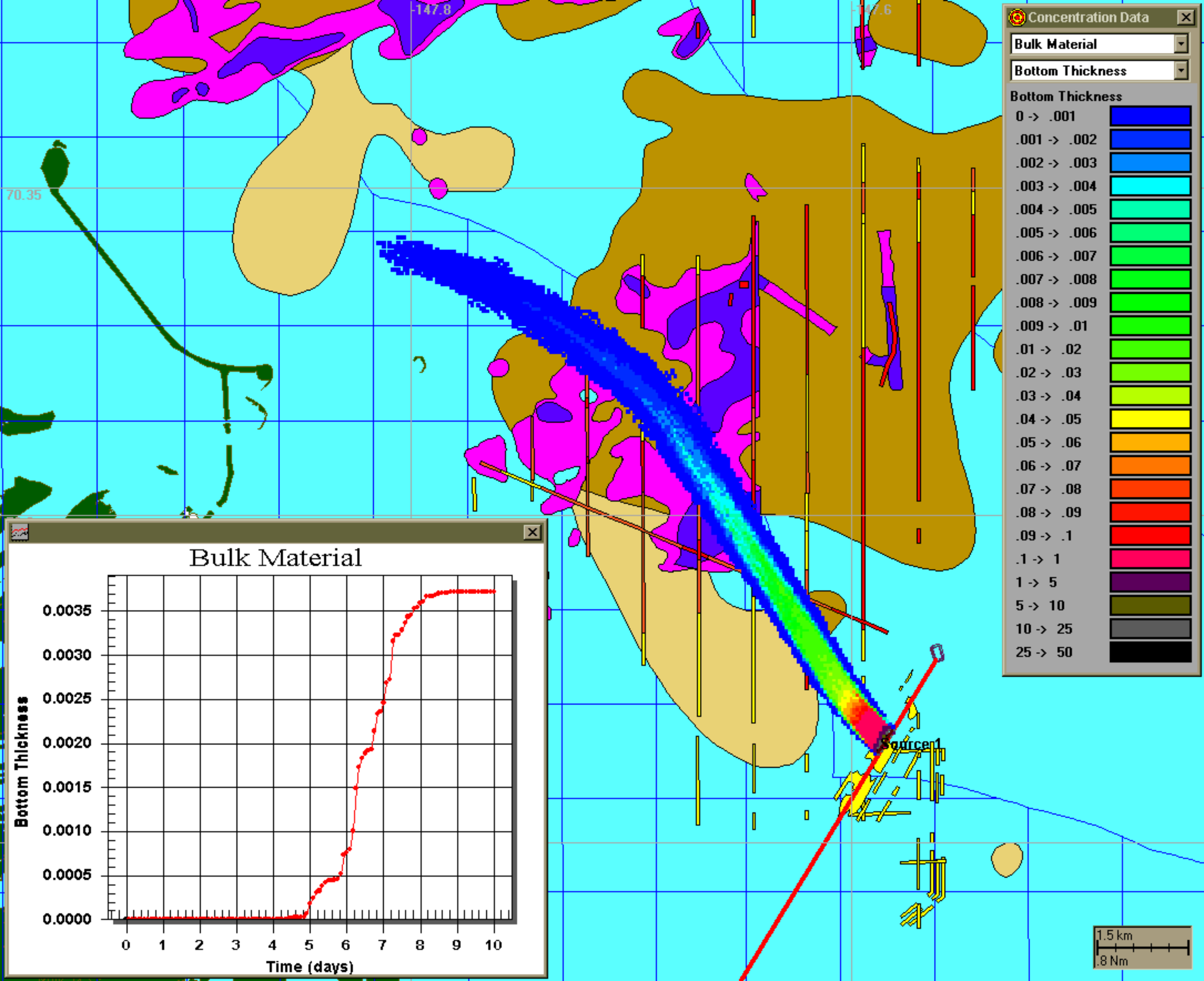

Concentration Data

Bulk Material

Bottom Thickness

Bottom Thickness

0 -> .001	[Dark Blue]
.001 -> .002	[Blue]
.002 -> .003	[Light Blue]
.003 -> .004	[Cyan]
.004 -> .005	[Green-Cyan]
.005 -> .006	[Green]
.006 -> .007	[Light Green]
.007 -> .008	[Green]
.008 -> .009	[Light Green]
.009 -> .01	[Green]
.01 -> .02	[Light Green]
.02 -> .03	[Yellow-Green]
.03 -> .04	[Yellow]
.04 -> .05	[Light Yellow]
.05 -> .06	[Orange]
.06 -> .07	[Red-Orange]
.07 -> .08	[Red]
.08 -> .09	[Dark Red]
.09 -> .1	[Red]
.1 -> 1	[Magenta]
1 -> 5	[Purple]
5 -> 10	[Dark Purple]
10 -> 25	[Grey]
25 -> 50	[Black]

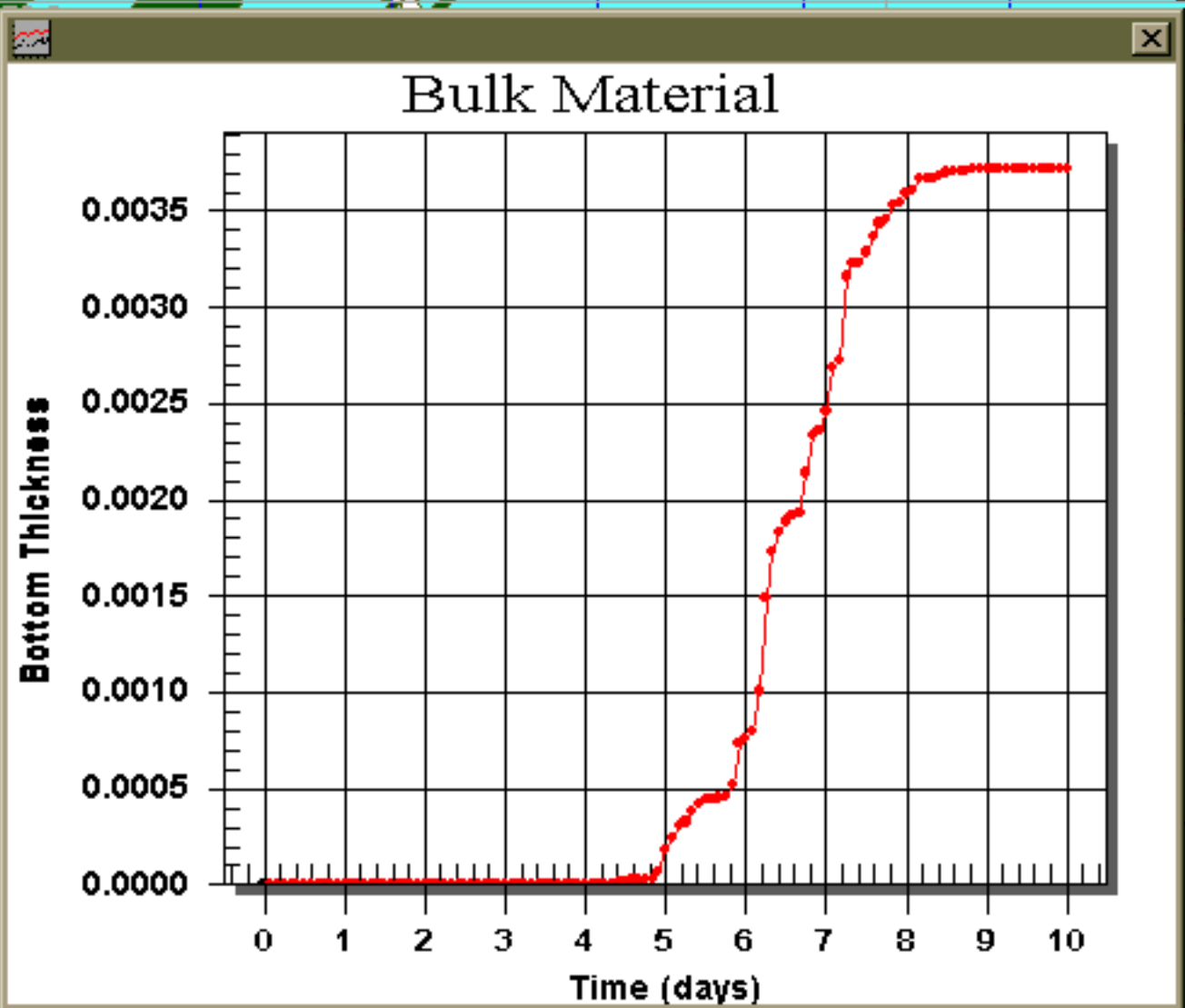

1.5 km
8 Nm

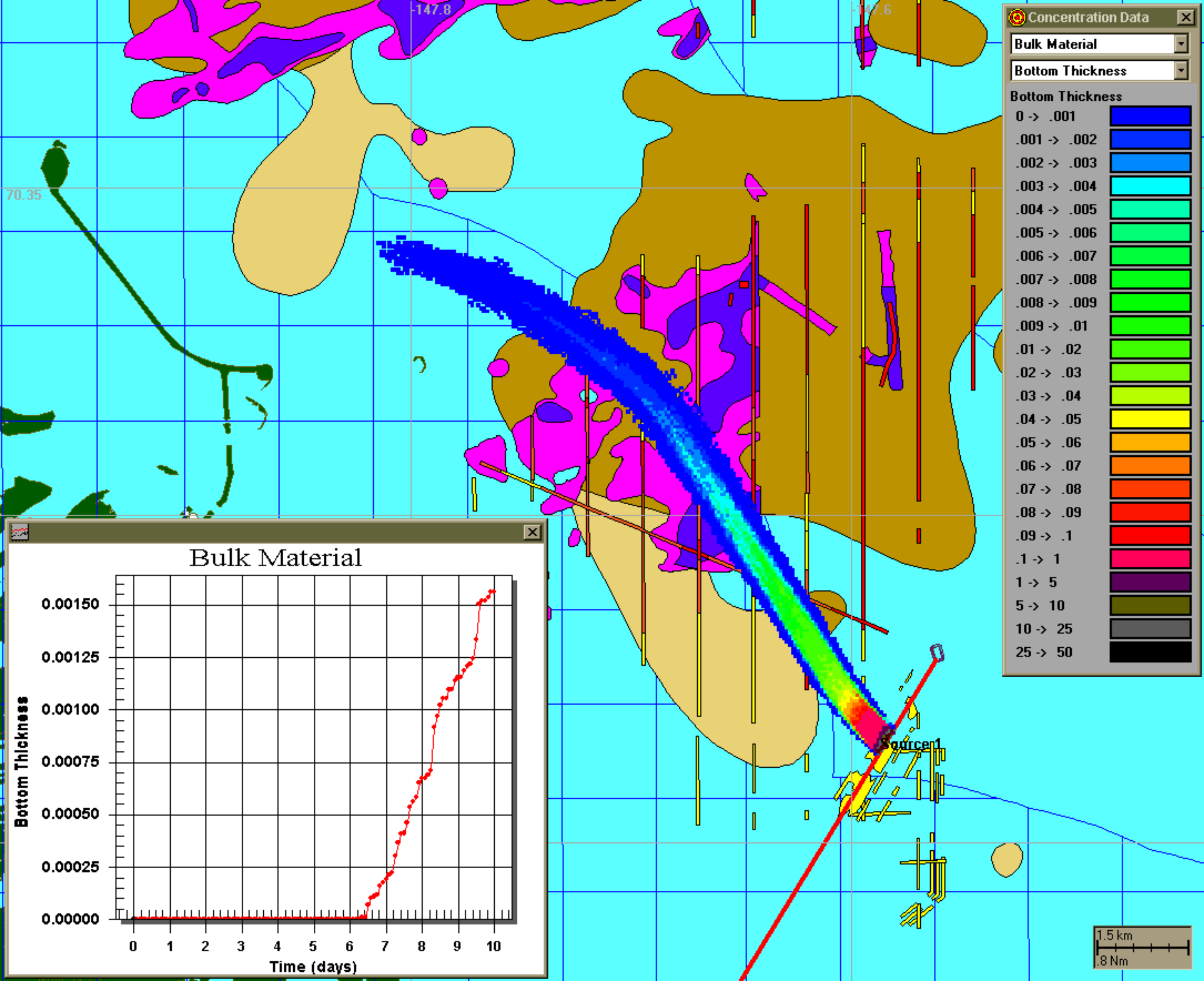

Bulk Material

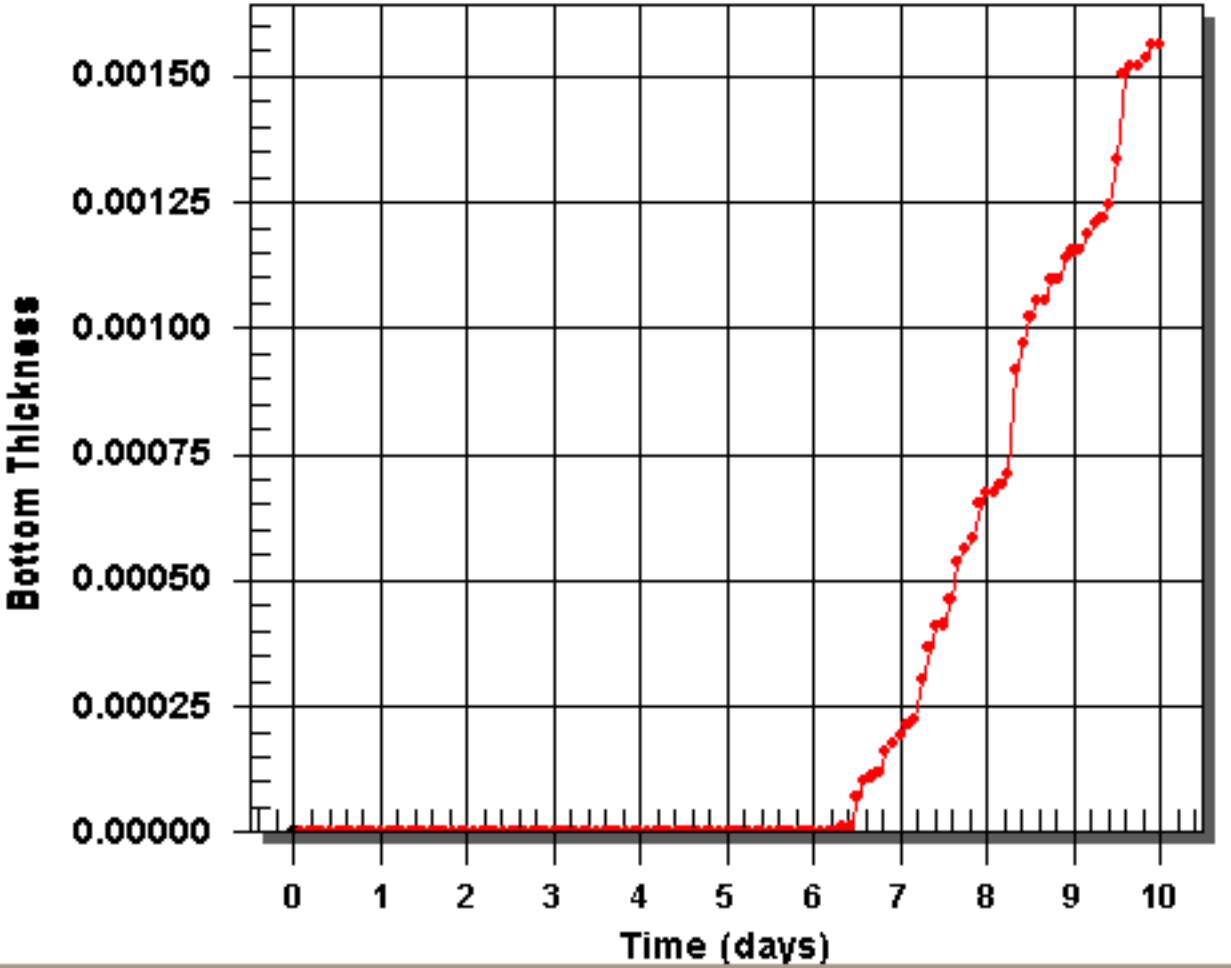

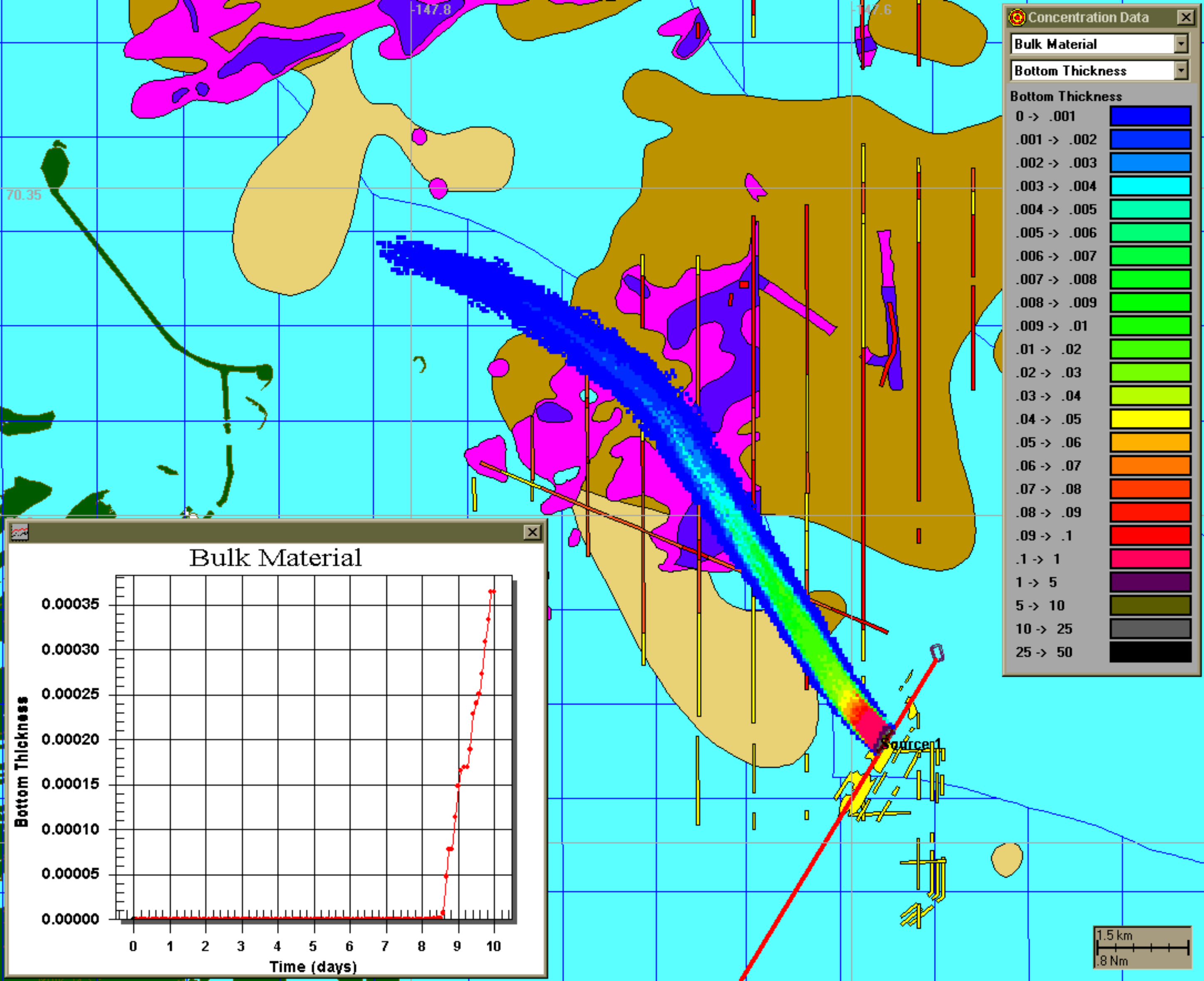

Bulk Material

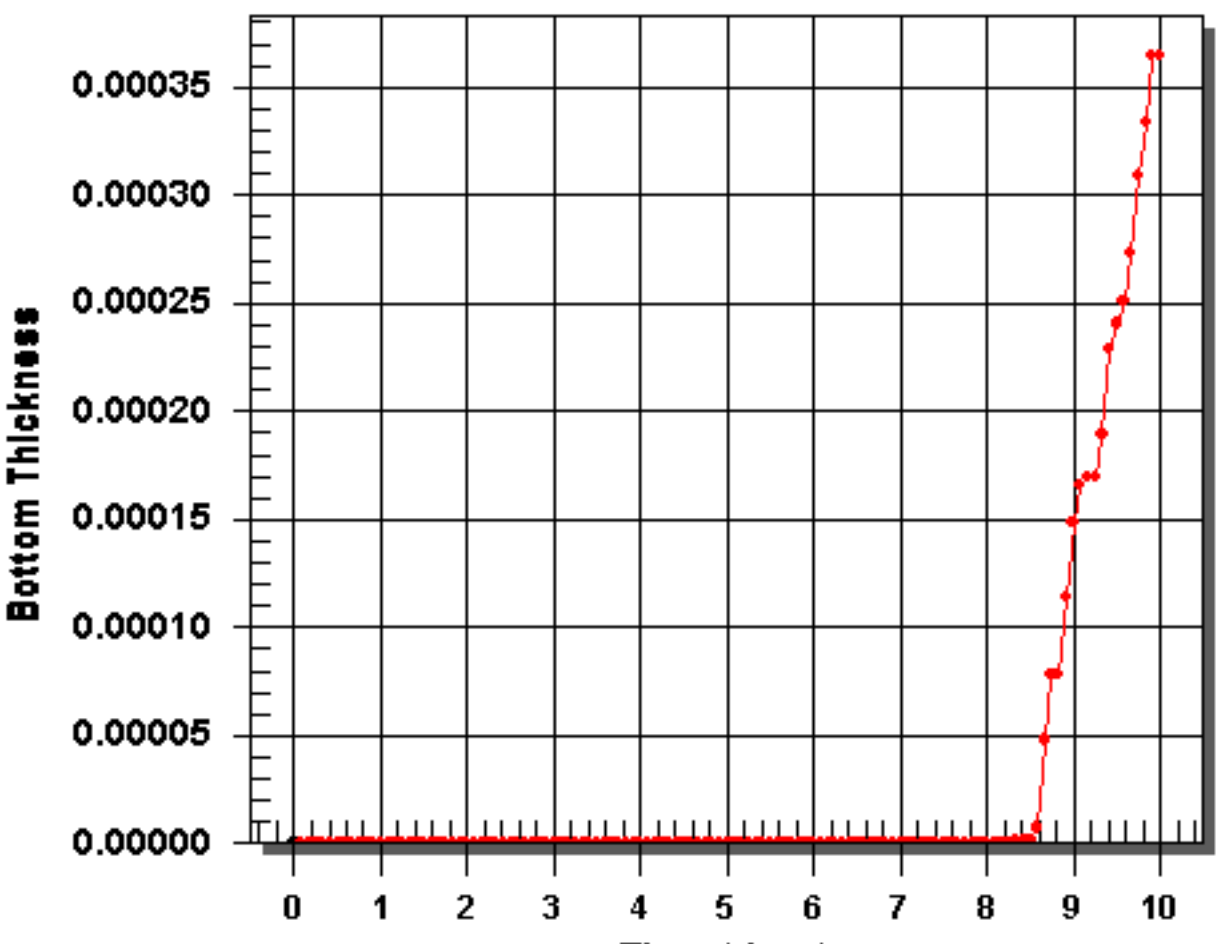

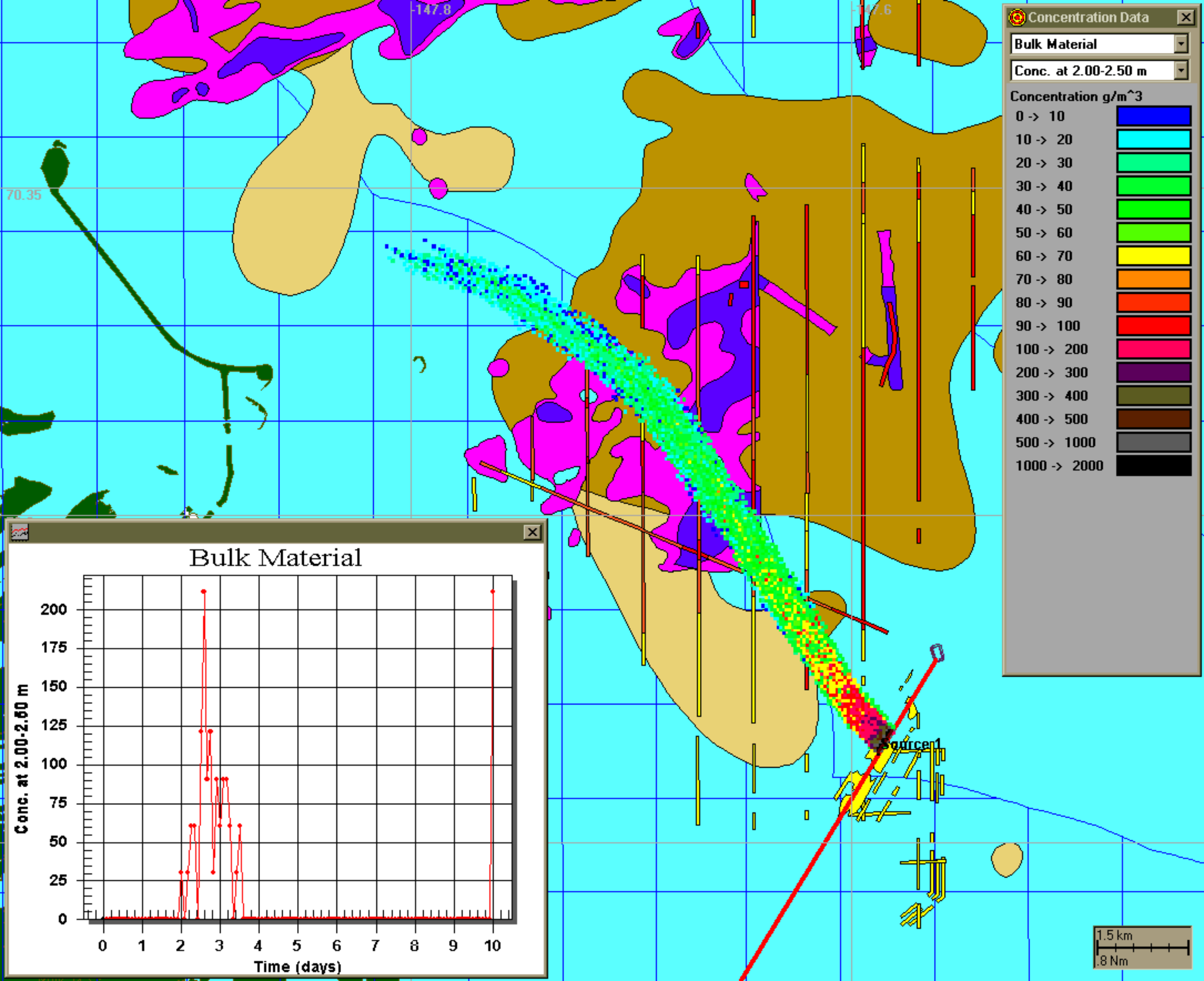

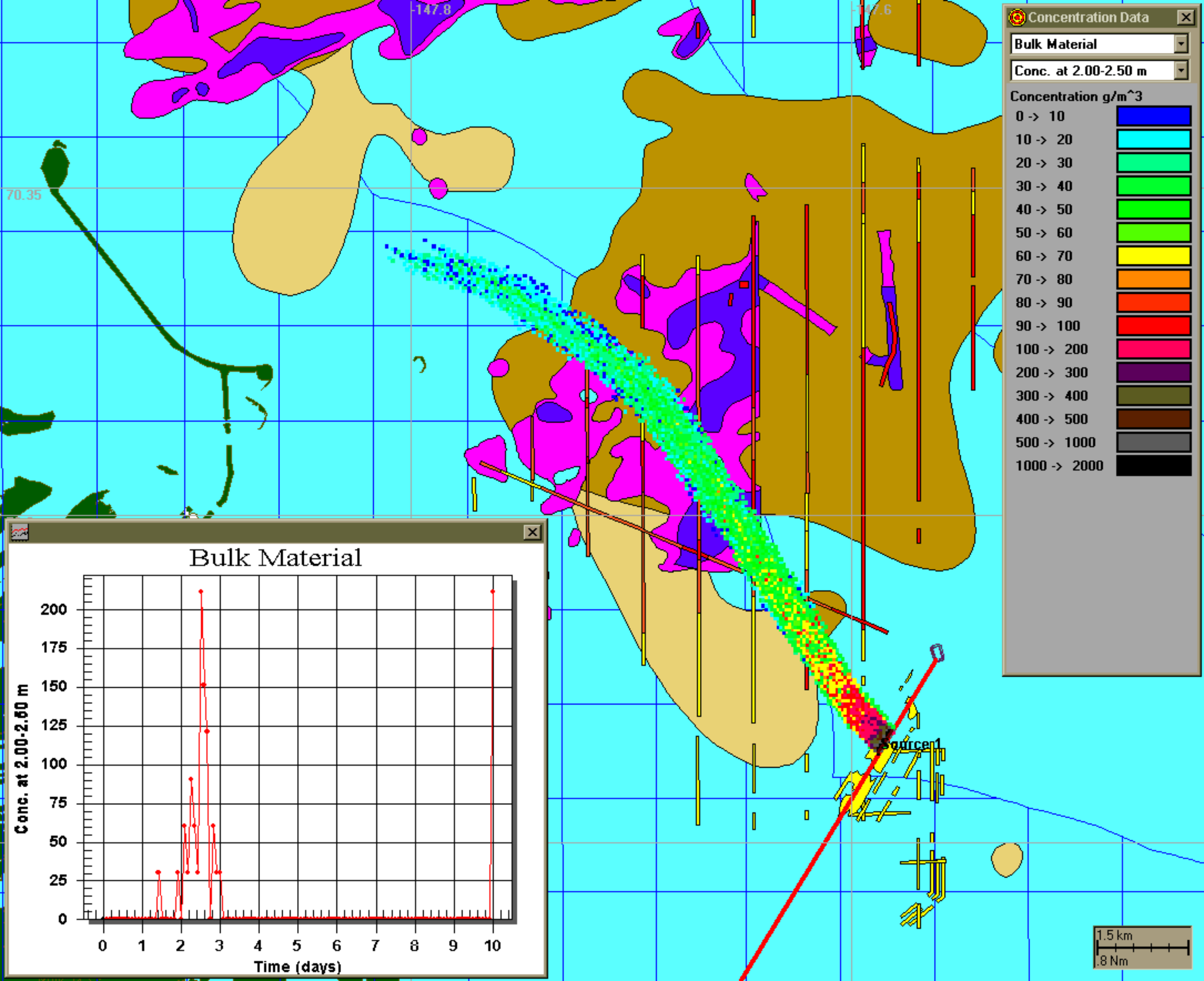

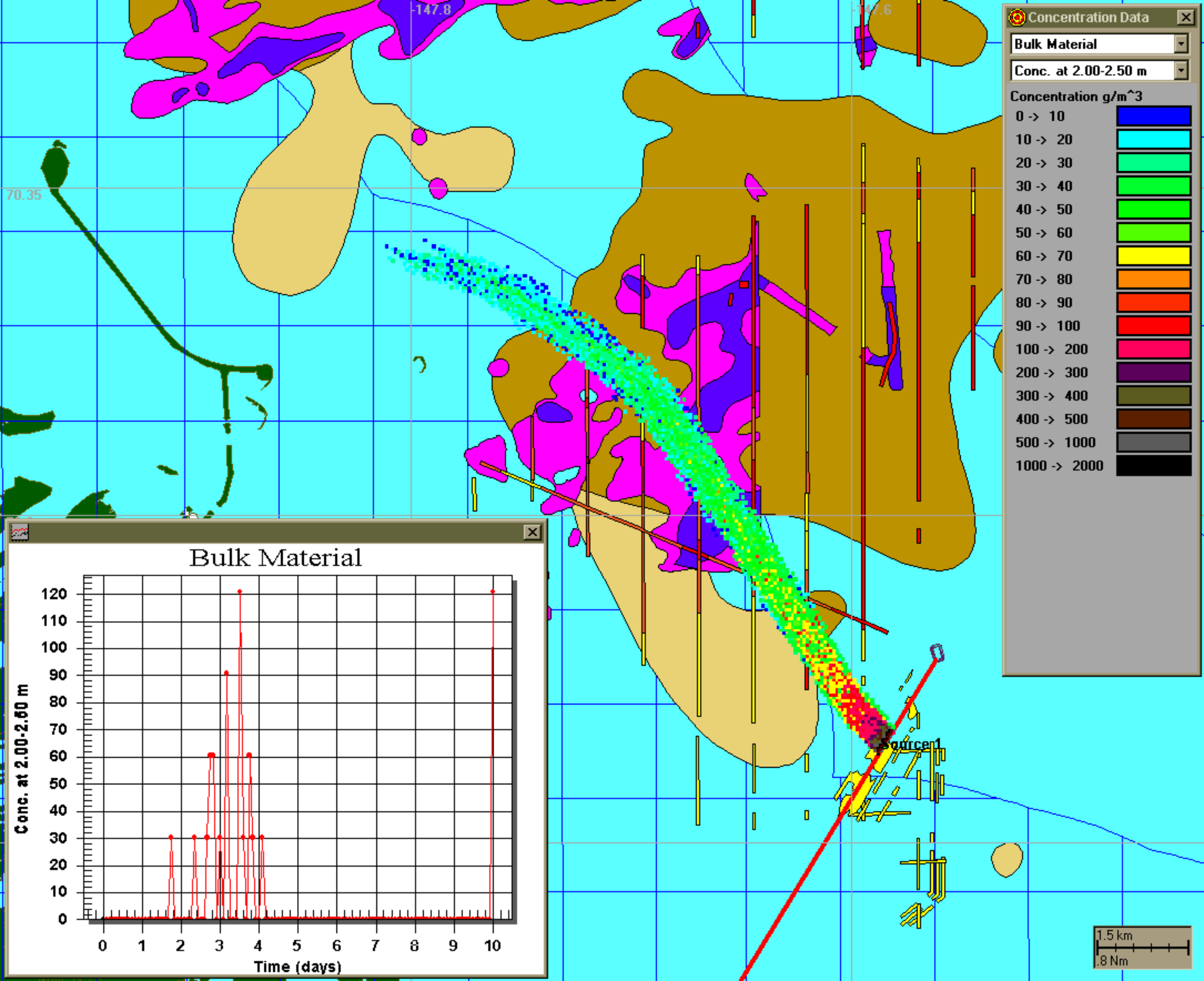

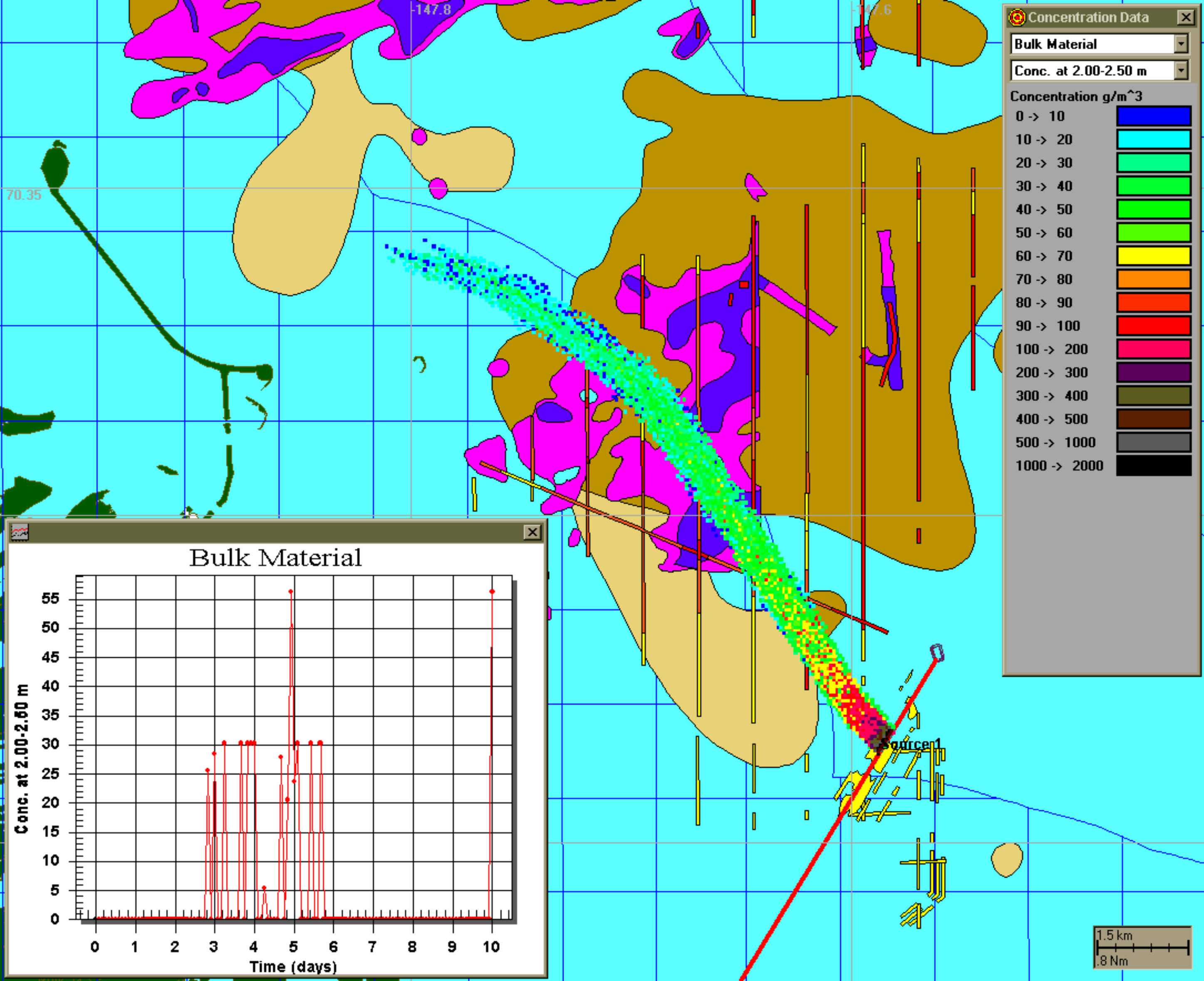

Concentration Data

Bulk Material

Conc. at 2.00-2.50 m

Concentration g/m³

0 -> 10	Blue
10 -> 20	Cyan
20 -> 30	Light Green
30 -> 40	Green
40 -> 50	Bright Green
50 -> 60	Yellow-Green
60 -> 70	Yellow
70 -> 80	Orange
80 -> 90	Red-Orange
90 -> 100	Red
100 -> 200	Magenta
200 -> 300	Purple
300 -> 400	Olive
400 -> 500	Brown
500 -> 1000	Grey
1000 -> 2000	Black

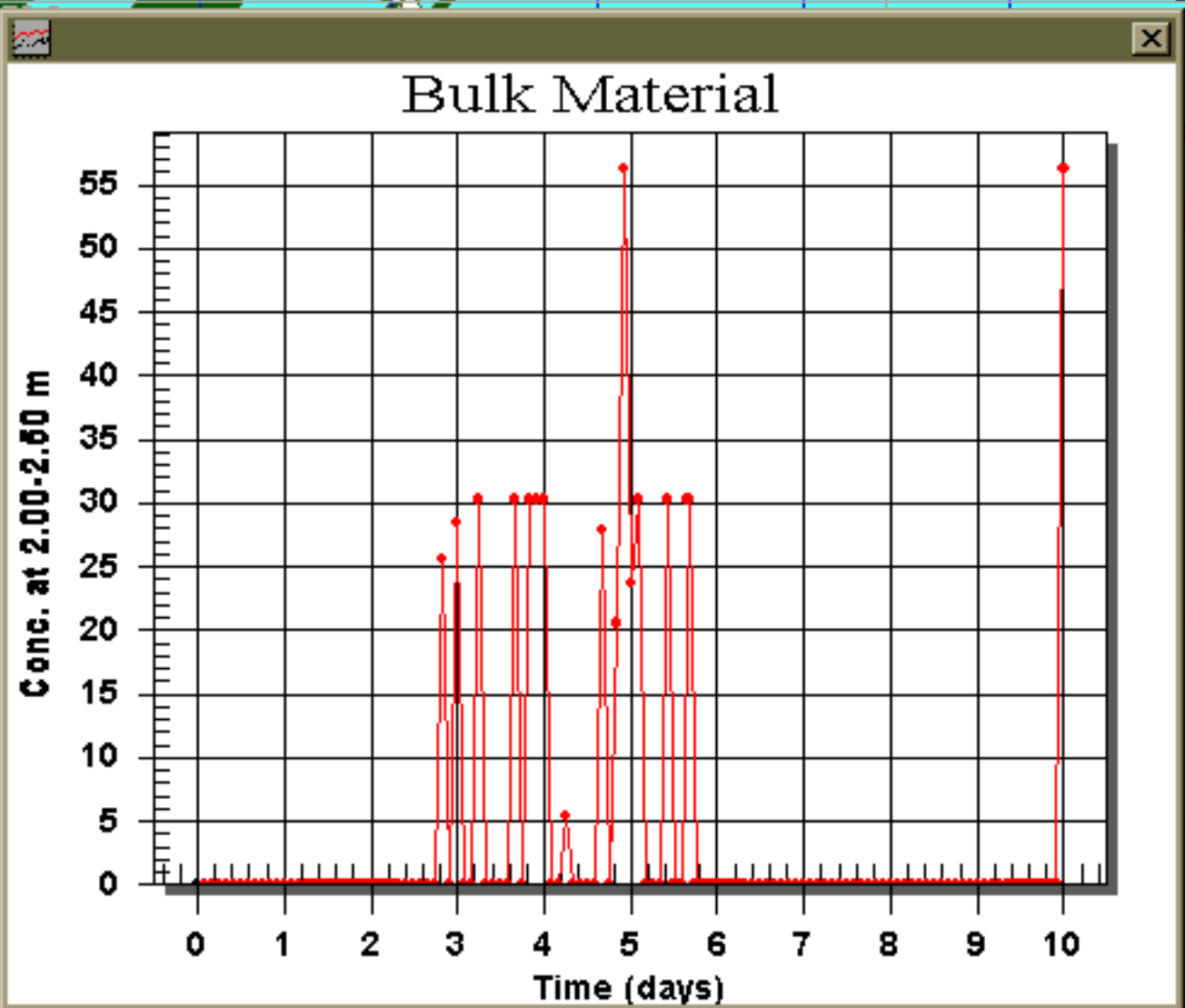

1.5 km
0.8 Nm

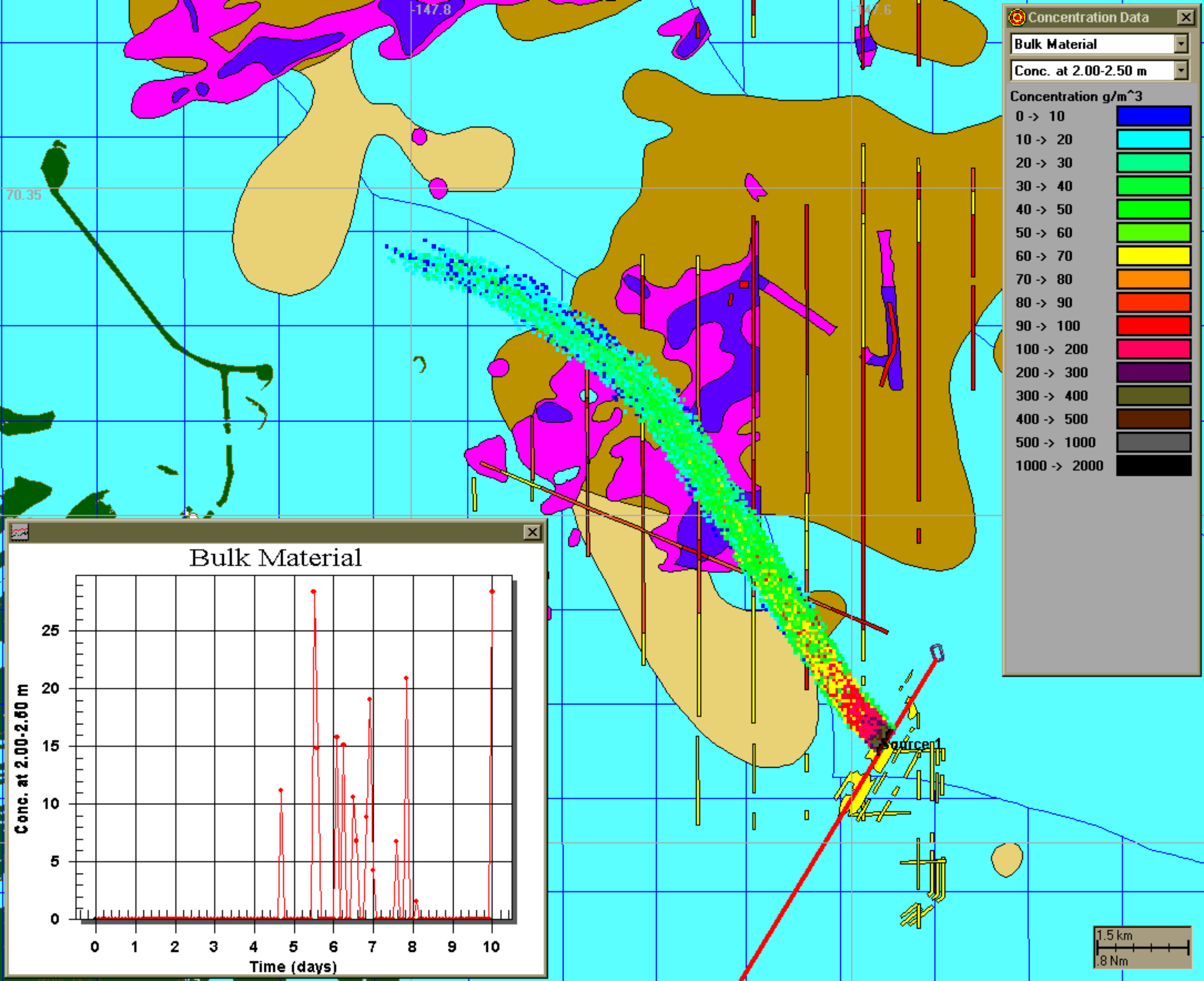

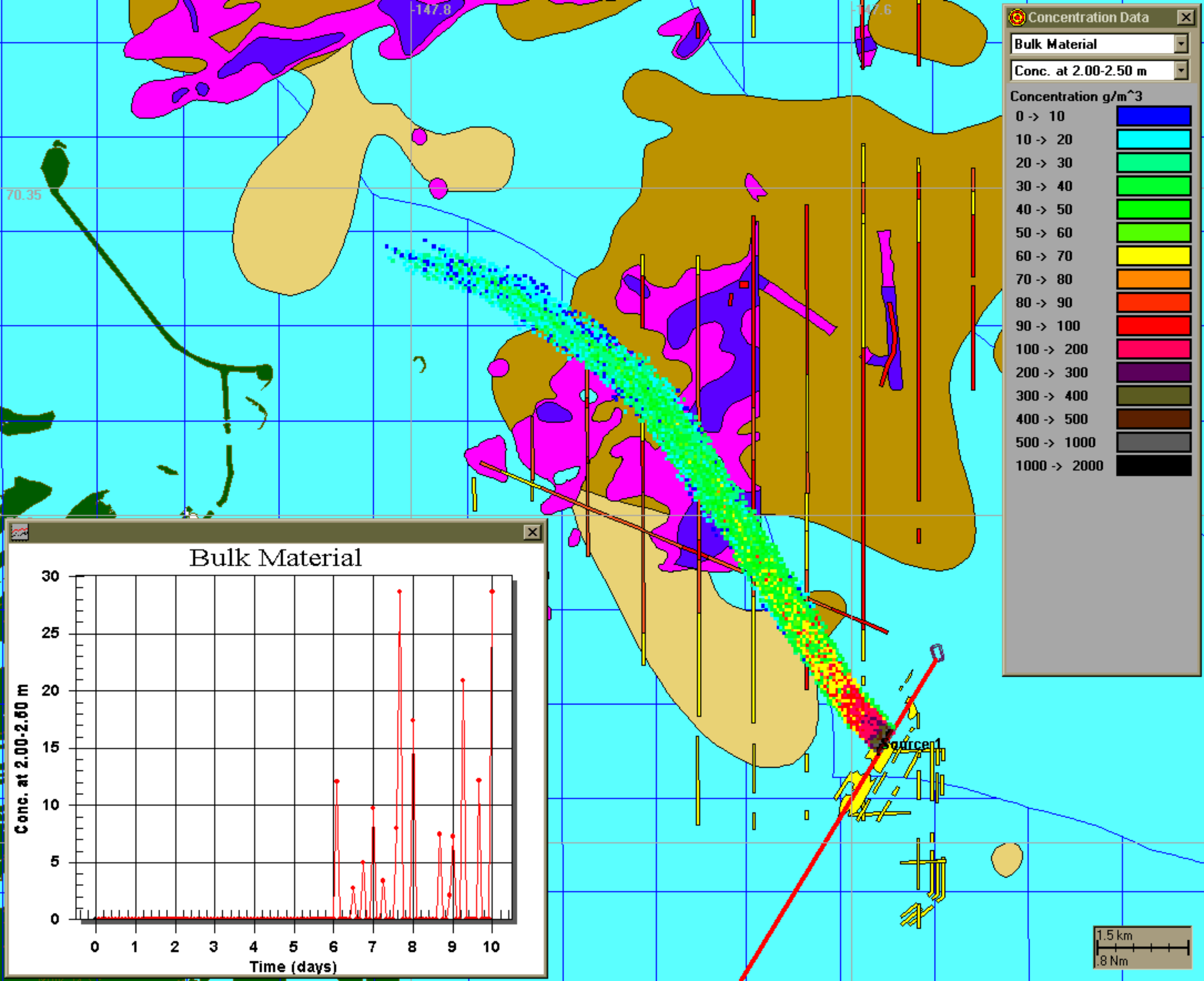

Concentration Data

Bulk Material

Conc. at 2.00-2.50 m

Concentration g/m^3

0 -> 10	Blue
10 -> 20	Cyan
20 -> 30	Light Green
30 -> 40	Green
40 -> 50	Bright Green
50 -> 60	Yellow-Green
60 -> 70	Yellow
70 -> 80	Orange
80 -> 90	Red-Orange
90 -> 100	Red
100 -> 200	Magenta
200 -> 300	Purple
300 -> 400	Olive
400 -> 500	Brown
500 -> 1000	Grey
1000 -> 2000	Black

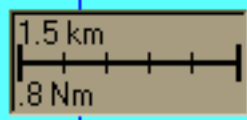
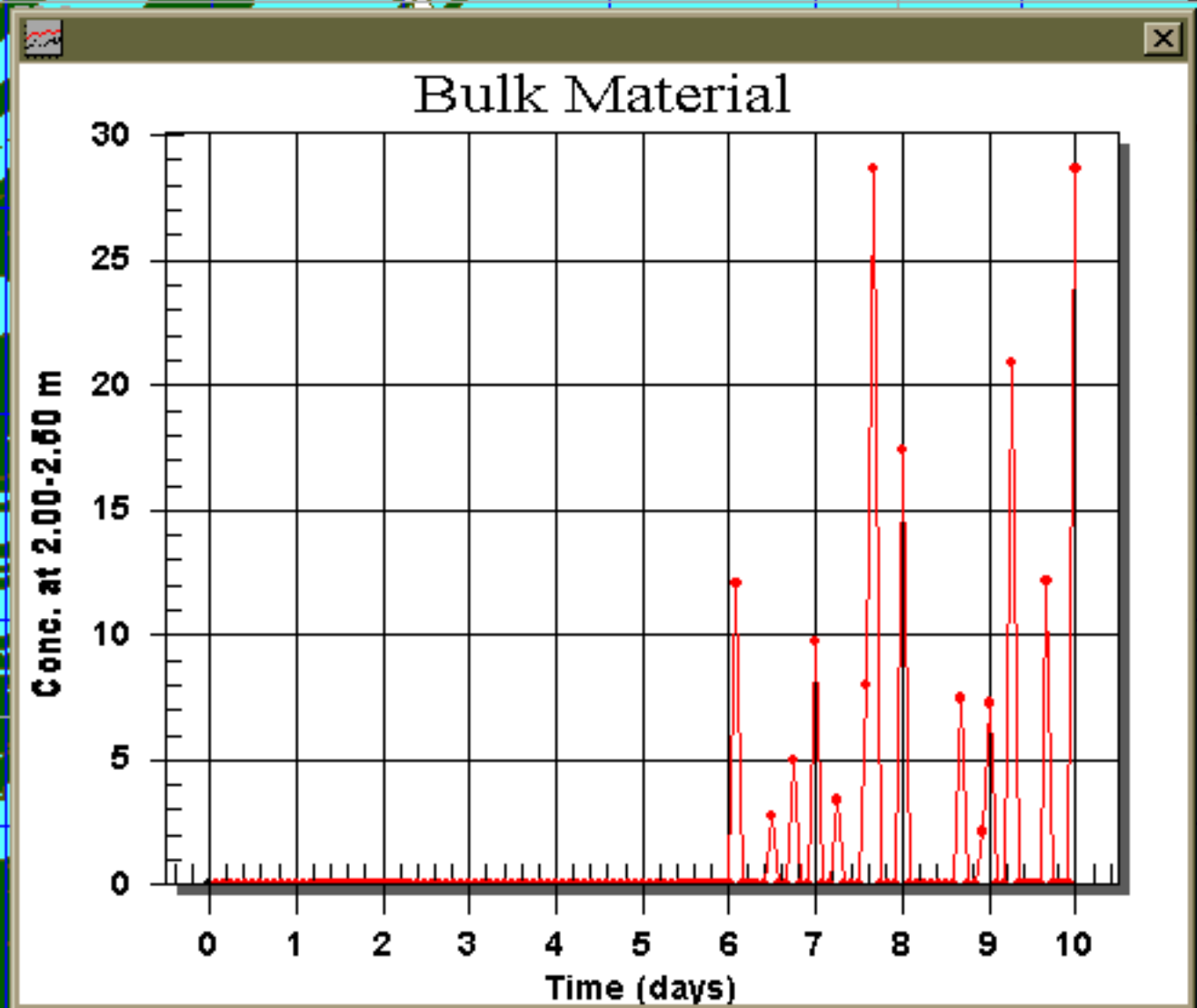

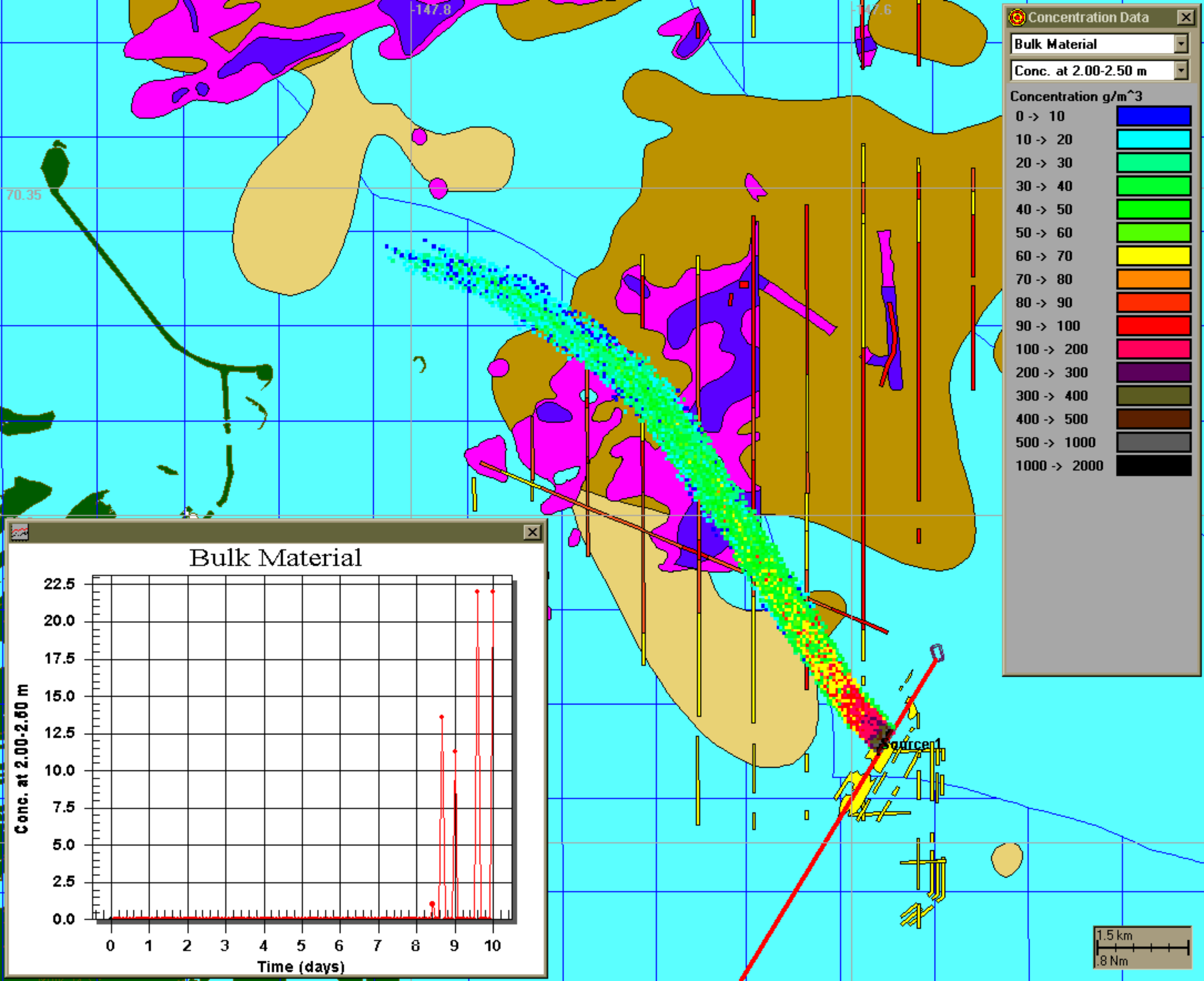

Concentration Data

Bulk Material

Conc. at 2.00-2.50 m

Concentration g/m^3

0 -> 10	Blue
10 -> 20	Cyan
20 -> 30	Light Green
30 -> 40	Green
40 -> 50	Bright Green
50 -> 60	Yellow-Green
60 -> 70	Yellow
70 -> 80	Orange
80 -> 90	Red-Orange
90 -> 100	Red
100 -> 200	Magenta
200 -> 300	Purple
300 -> 400	Olive
400 -> 500	Brown
500 -> 1000	Grey
1000 -> 2000	Black

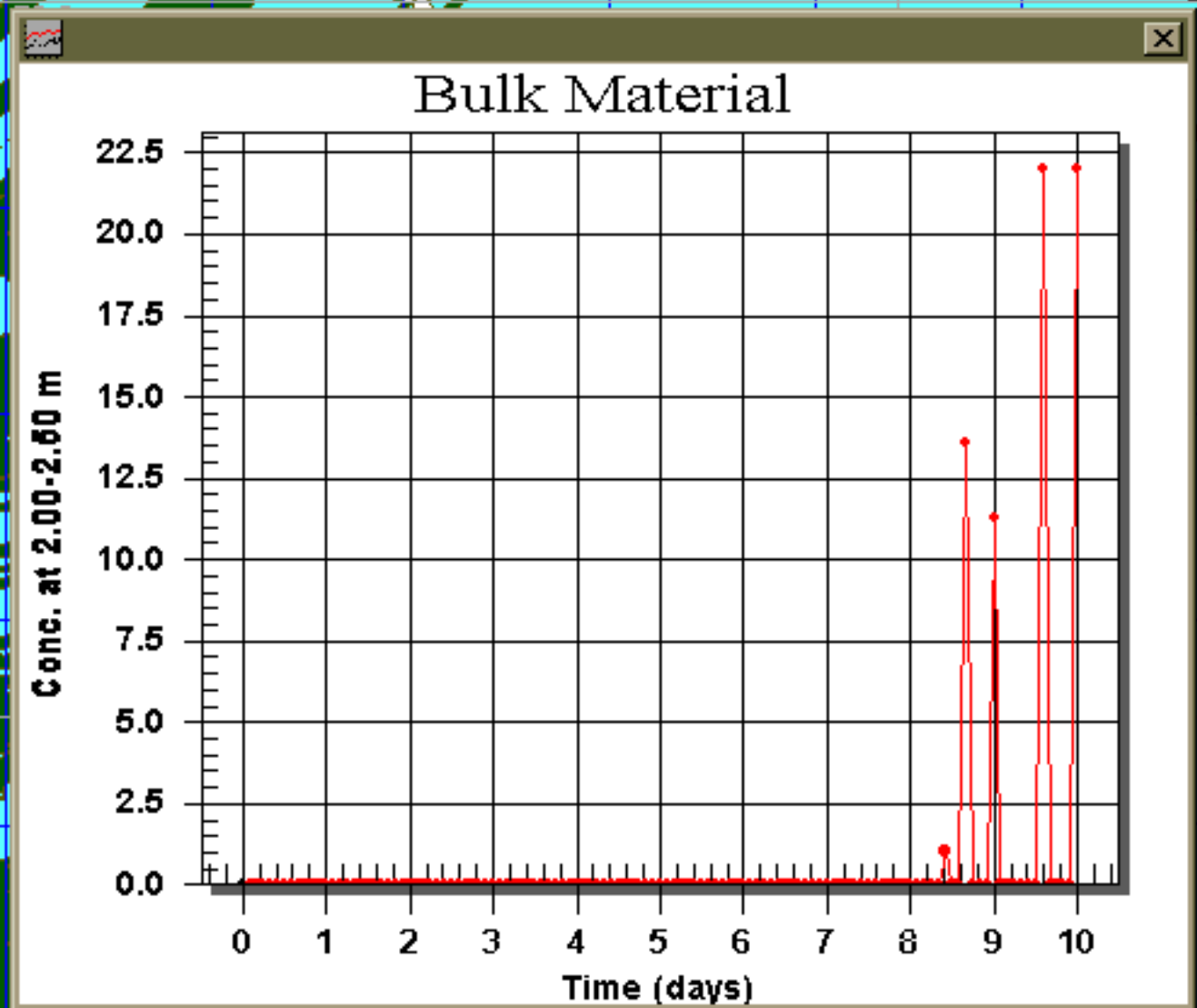

1.5 km
0.8 Nm

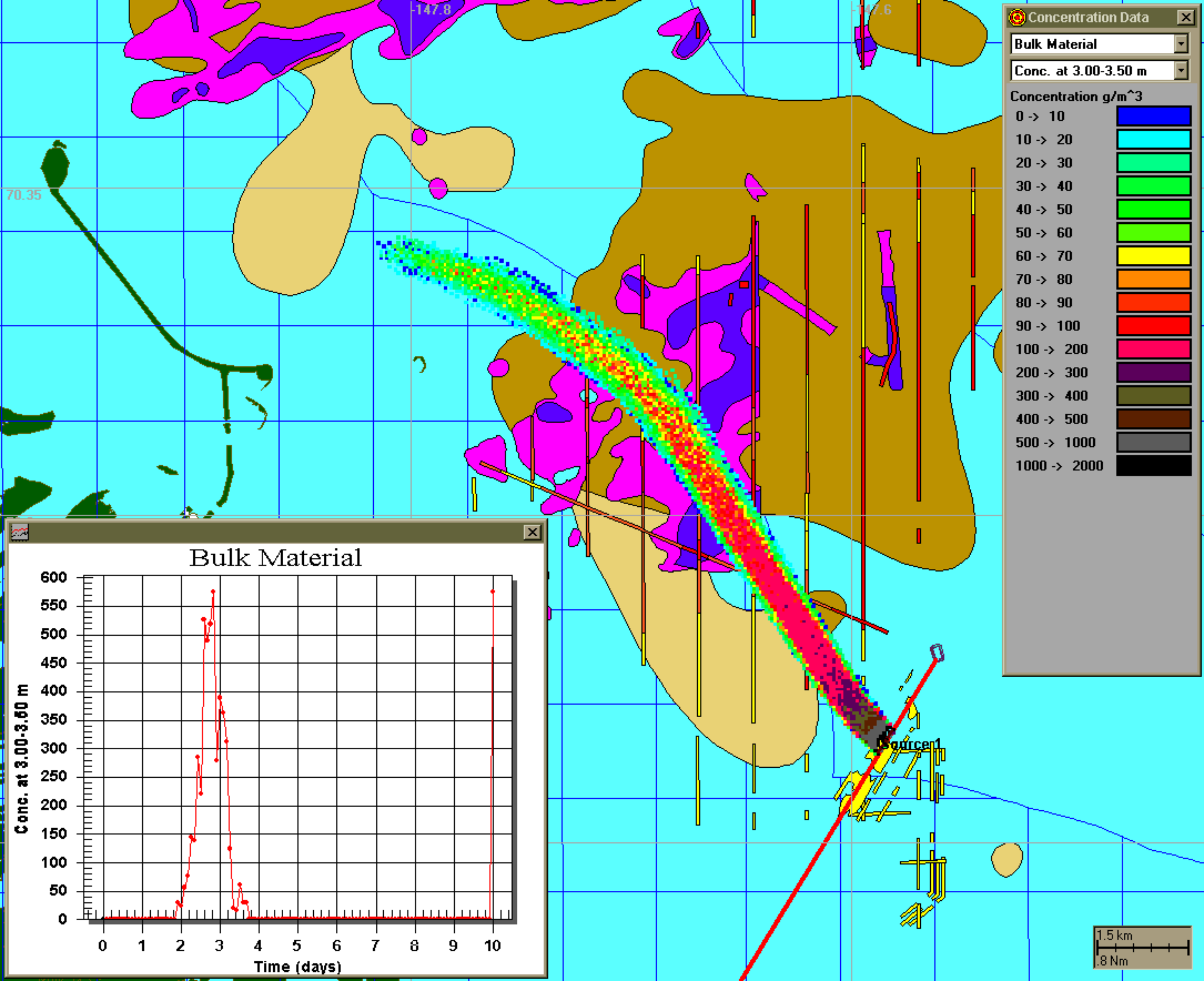

Concentration Data

Bulk Material

Conc. at 3.00-3.50 m

Concentration g/m^3

- 0 -> 10
- 10 -> 20
- 20 -> 30
- 30 -> 40
- 40 -> 50
- 50 -> 60
- 60 -> 70
- 70 -> 80
- 80 -> 90
- 90 -> 100
- 100 -> 200
- 200 -> 300
- 300 -> 400
- 400 -> 500
- 500 -> 1000
- 1000 -> 2000

Bulk Material

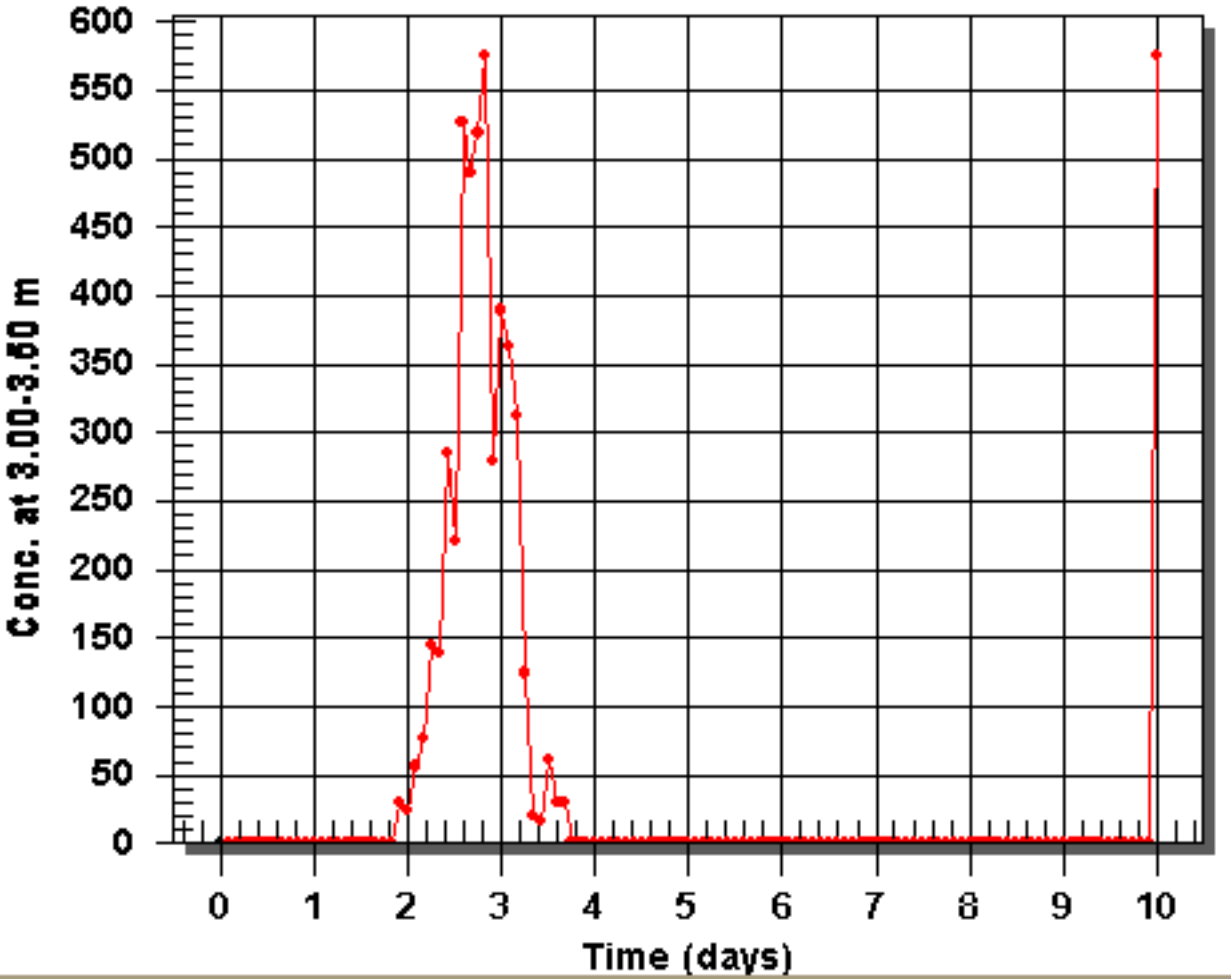

1.5 km
.8 Nm

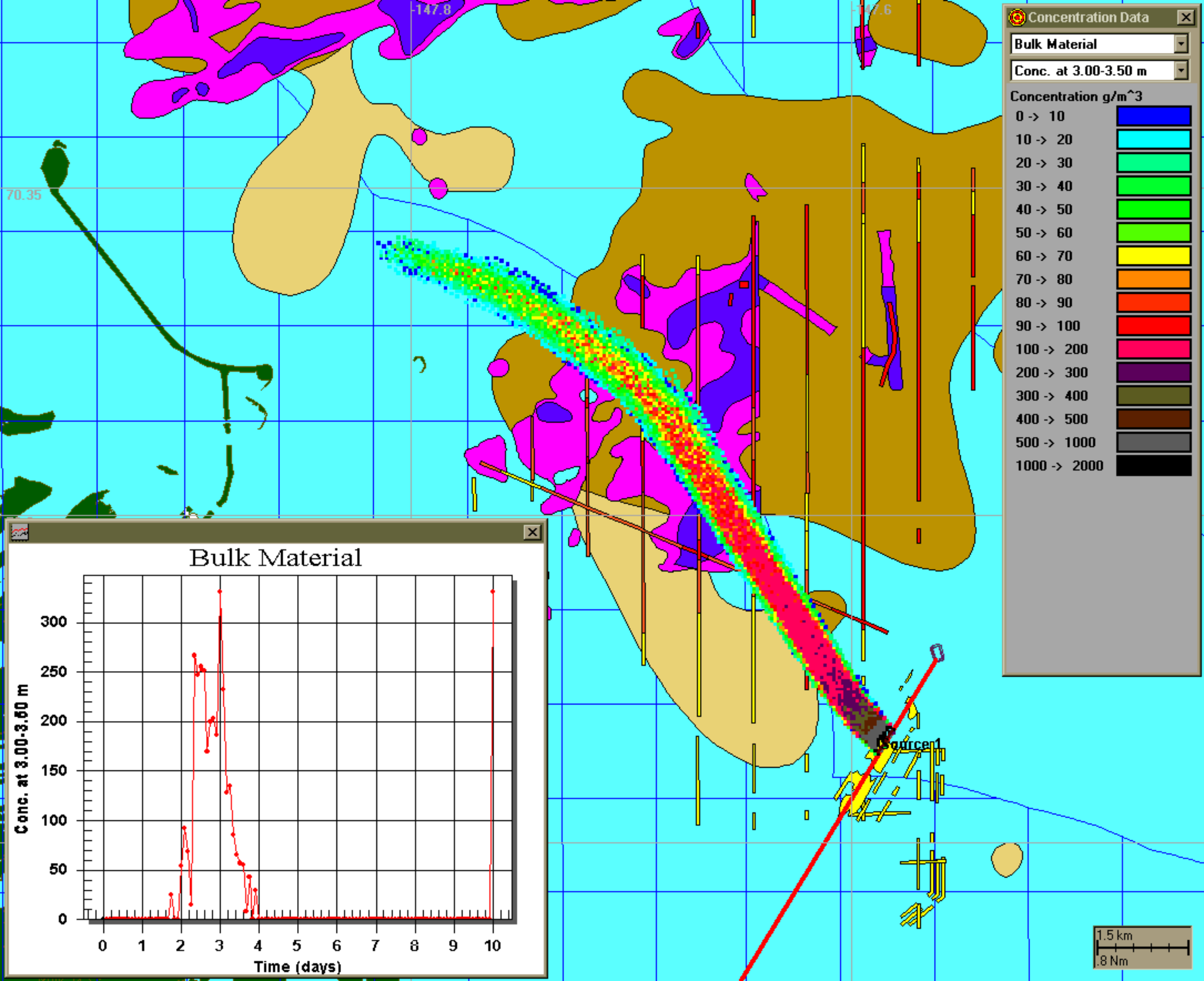

Concentration Data

Bulk Material

Conc. at 3.00-3.50 m

Concentration g/m³

0 -> 10	Blue
10 -> 20	Cyan
20 -> 30	Light Green
30 -> 40	Green
40 -> 50	Bright Green
50 -> 60	Yellow-Green
60 -> 70	Yellow
70 -> 80	Orange
80 -> 90	Red-Orange
90 -> 100	Red
100 -> 200	Pink
200 -> 300	Purple
300 -> 400	Olive
400 -> 500	Brown
500 -> 1000	Grey
1000 -> 2000	Black

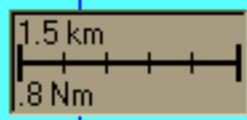
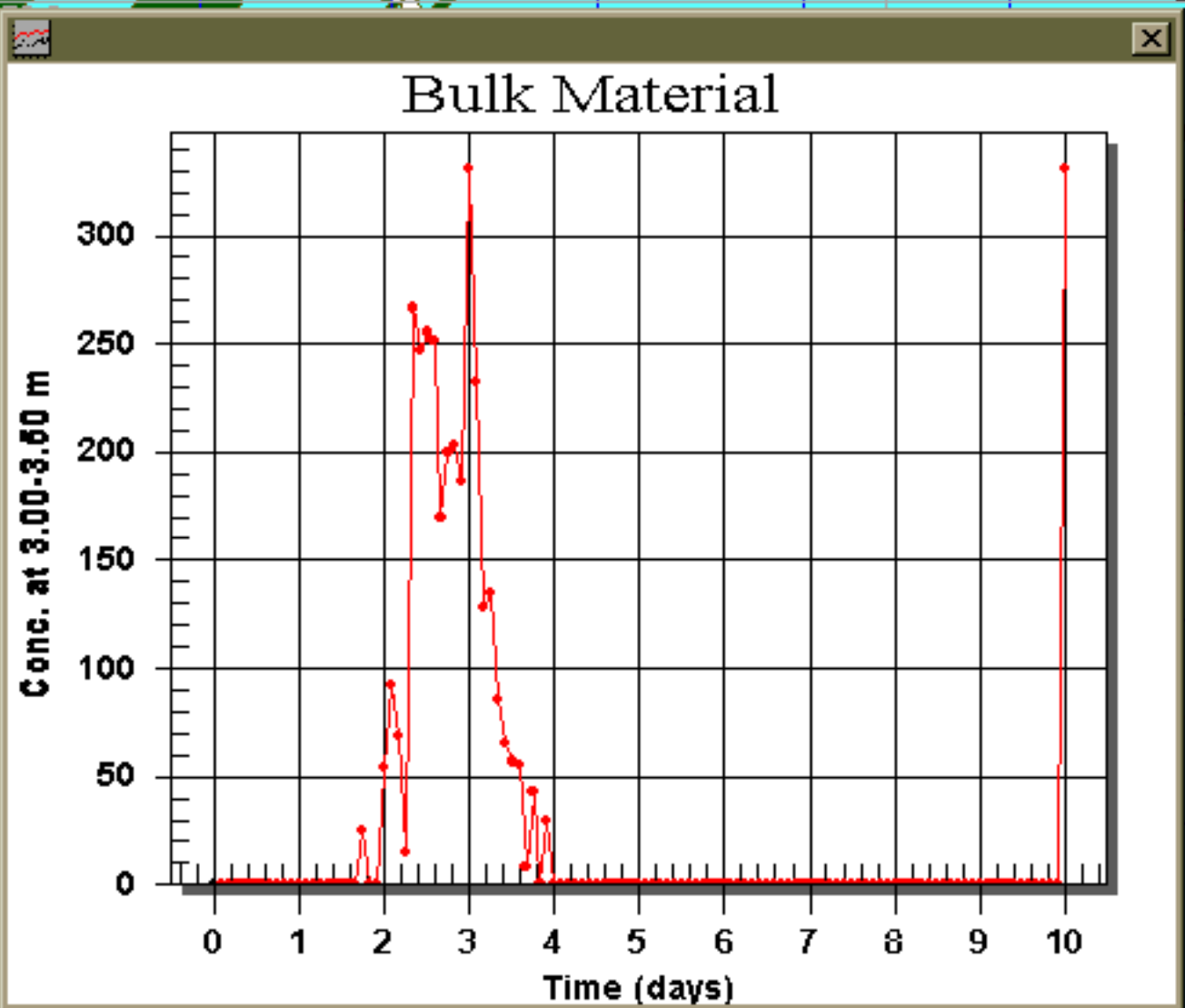

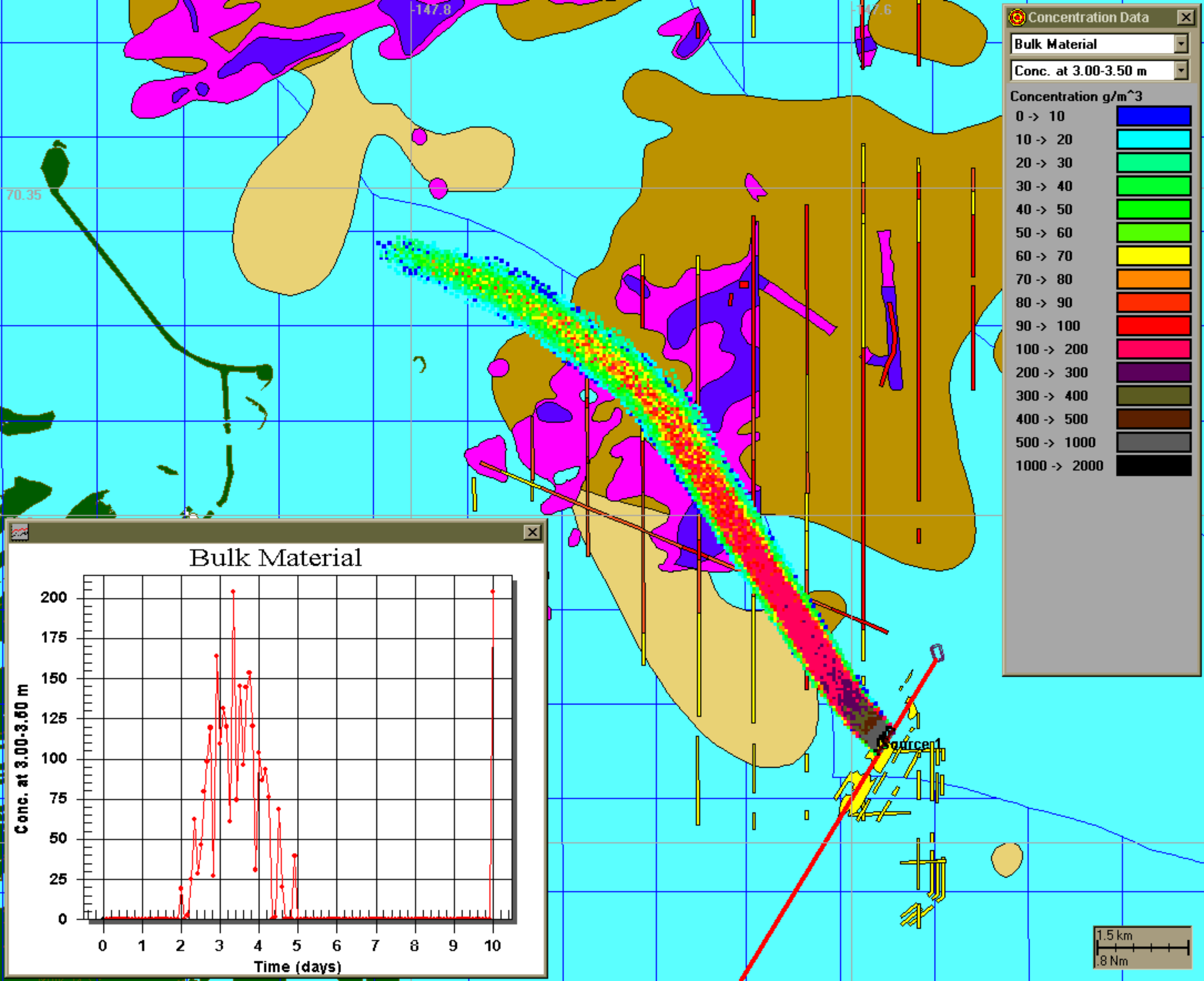

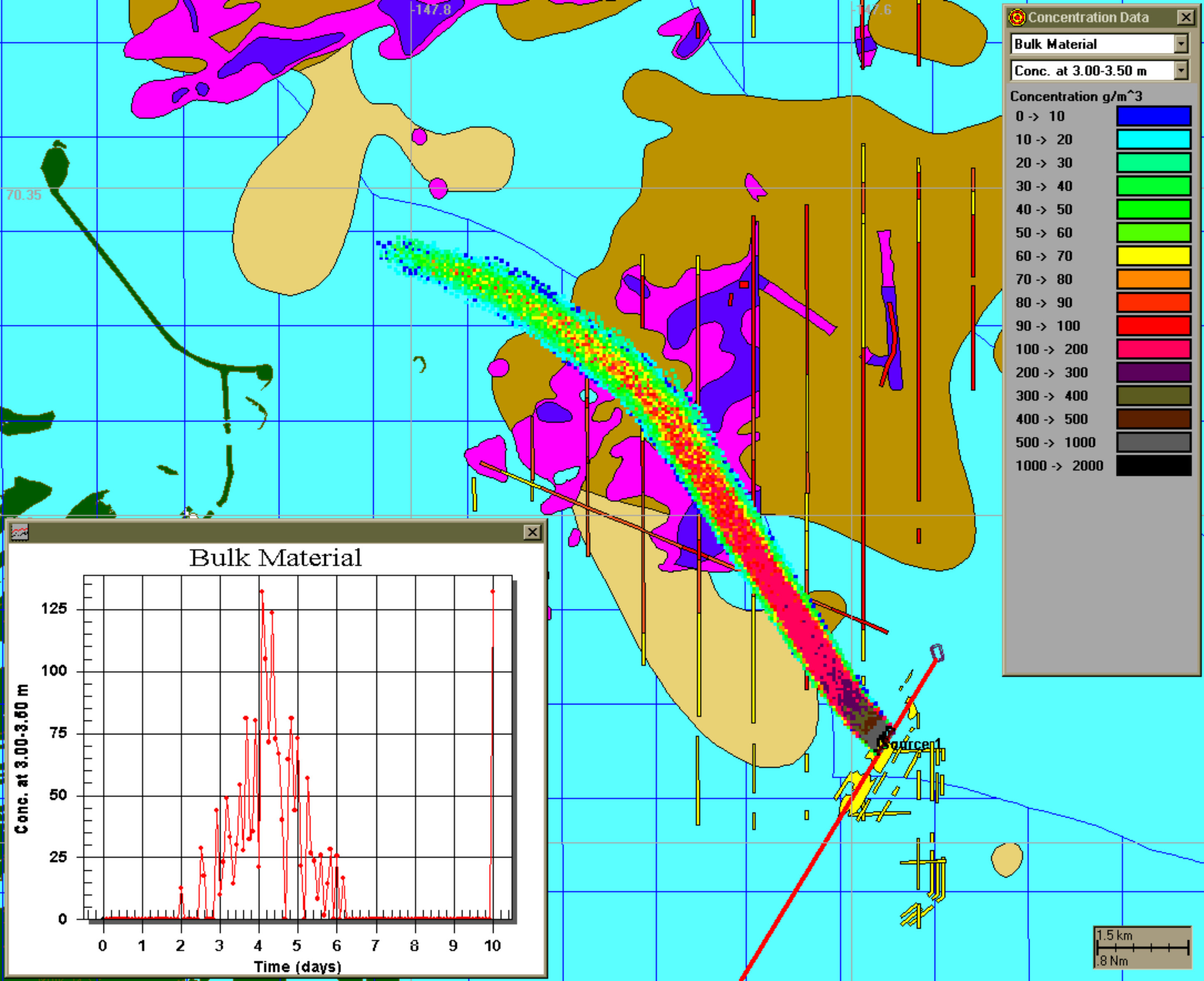

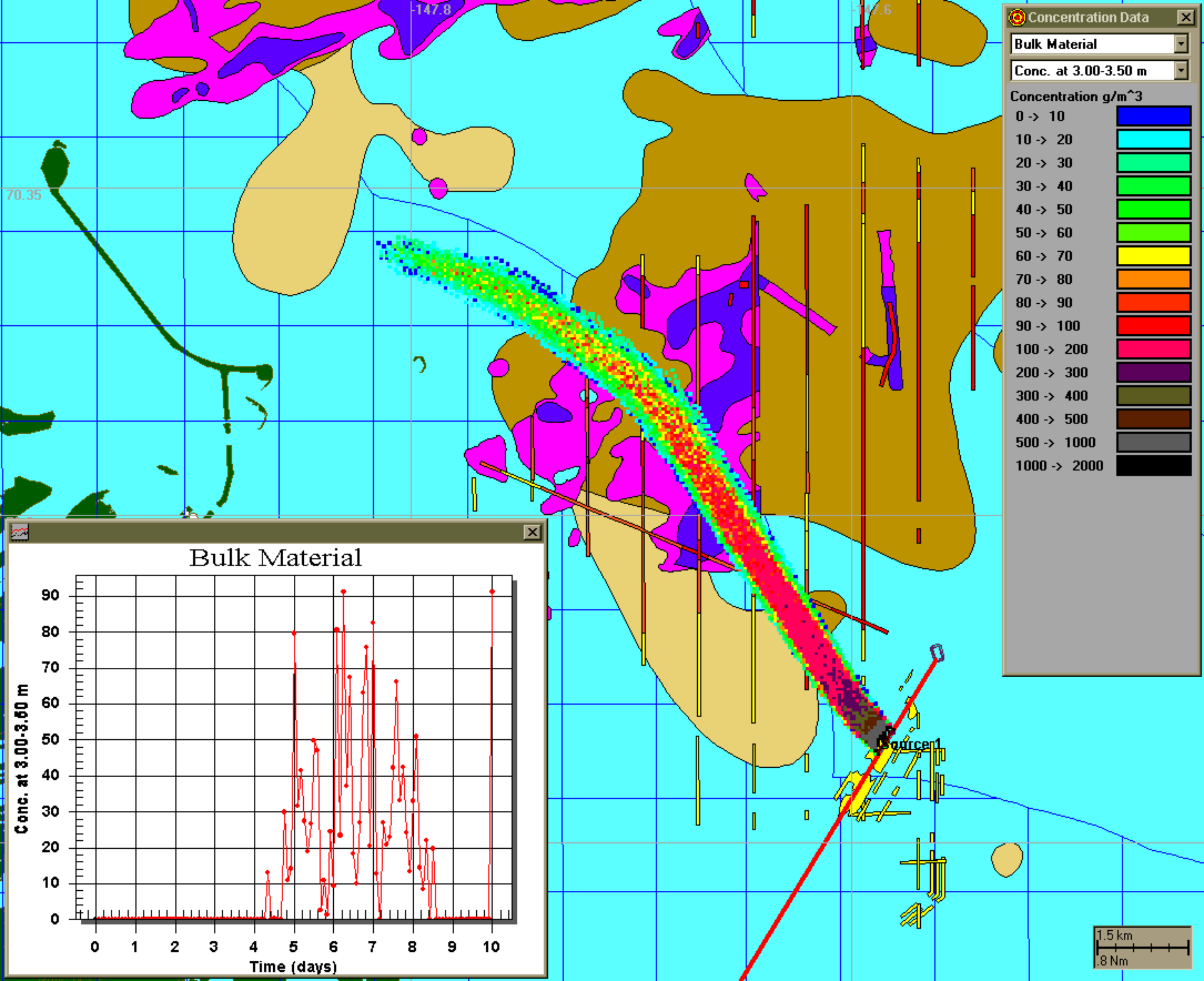

Concentration Data

Bulk Material

Conc. at 3.00-3.50 m

Concentration g/m³

0 -> 10	Blue
10 -> 20	Cyan
20 -> 30	Light Green
30 -> 40	Green
40 -> 50	Bright Green
50 -> 60	Yellow-Green
60 -> 70	Yellow
70 -> 80	Orange
80 -> 90	Red-Orange
90 -> 100	Red
100 -> 200	Magenta
200 -> 300	Purple
300 -> 400	Olive
400 -> 500	Brown
500 -> 1000	Grey
1000 -> 2000	Black

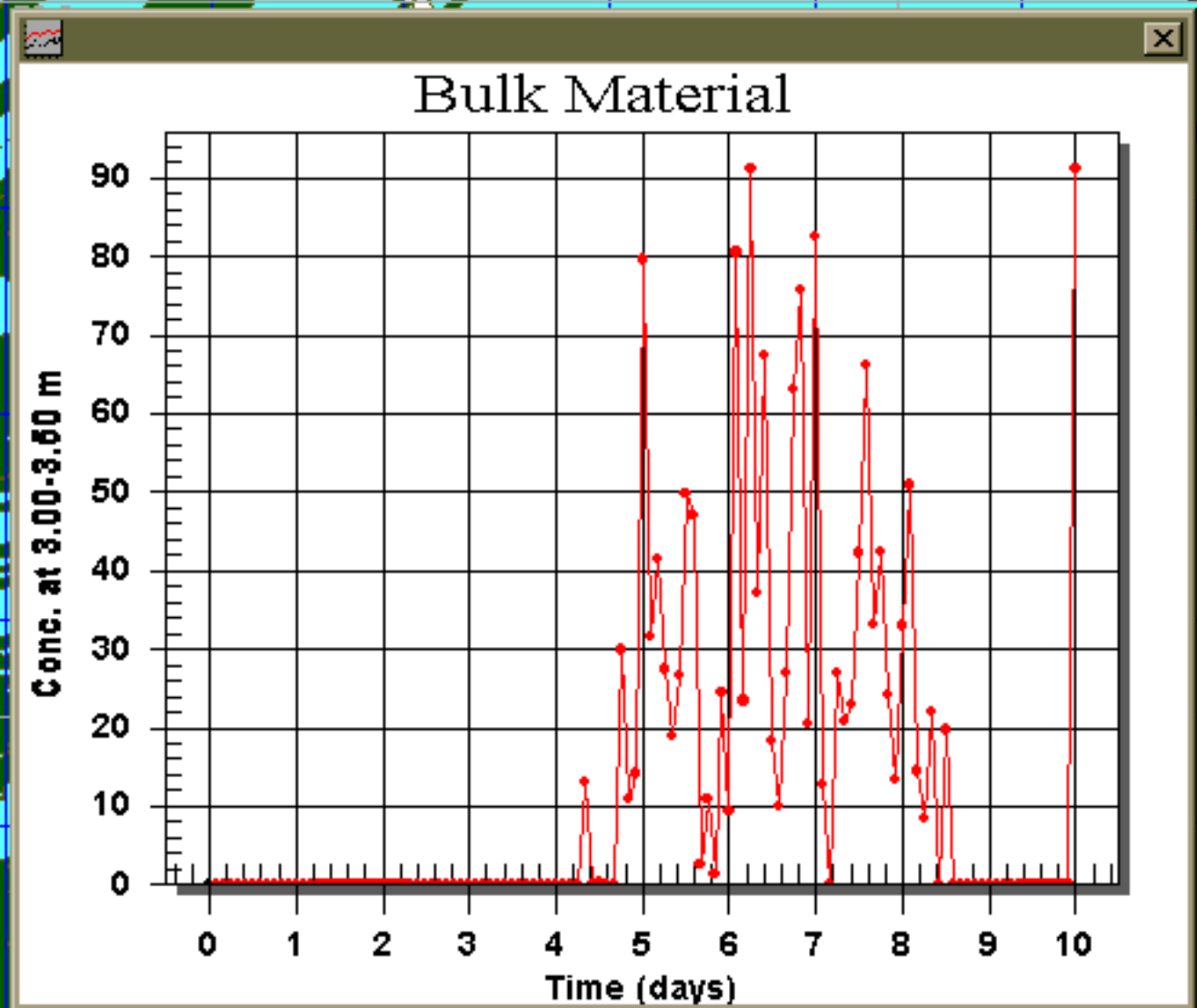

1.5 km
0.8 Nm

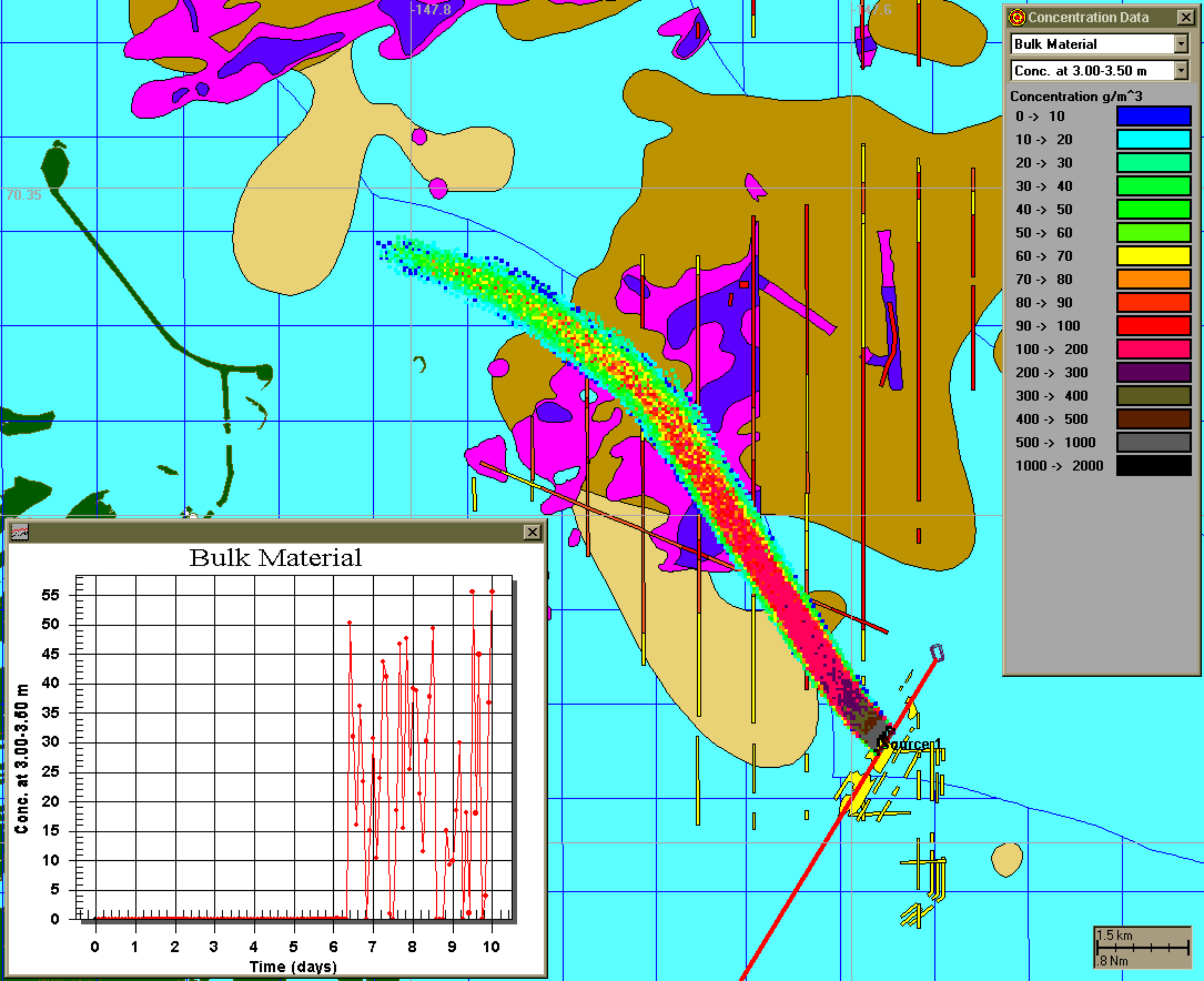

Concentration Data

Bulk Material

Conc. at 3.00-3.50 m

Concentration g/m³

0 -> 10	Blue
10 -> 20	Cyan
20 -> 30	Light Green
30 -> 40	Green
40 -> 50	Bright Green
50 -> 60	Yellow-Green
60 -> 70	Yellow
70 -> 80	Orange
80 -> 90	Red-Orange
90 -> 100	Red
100 -> 200	Pink
200 -> 300	Purple
300 -> 400	Olive
400 -> 500	Brown
500 -> 1000	Grey
1000 -> 2000	Black

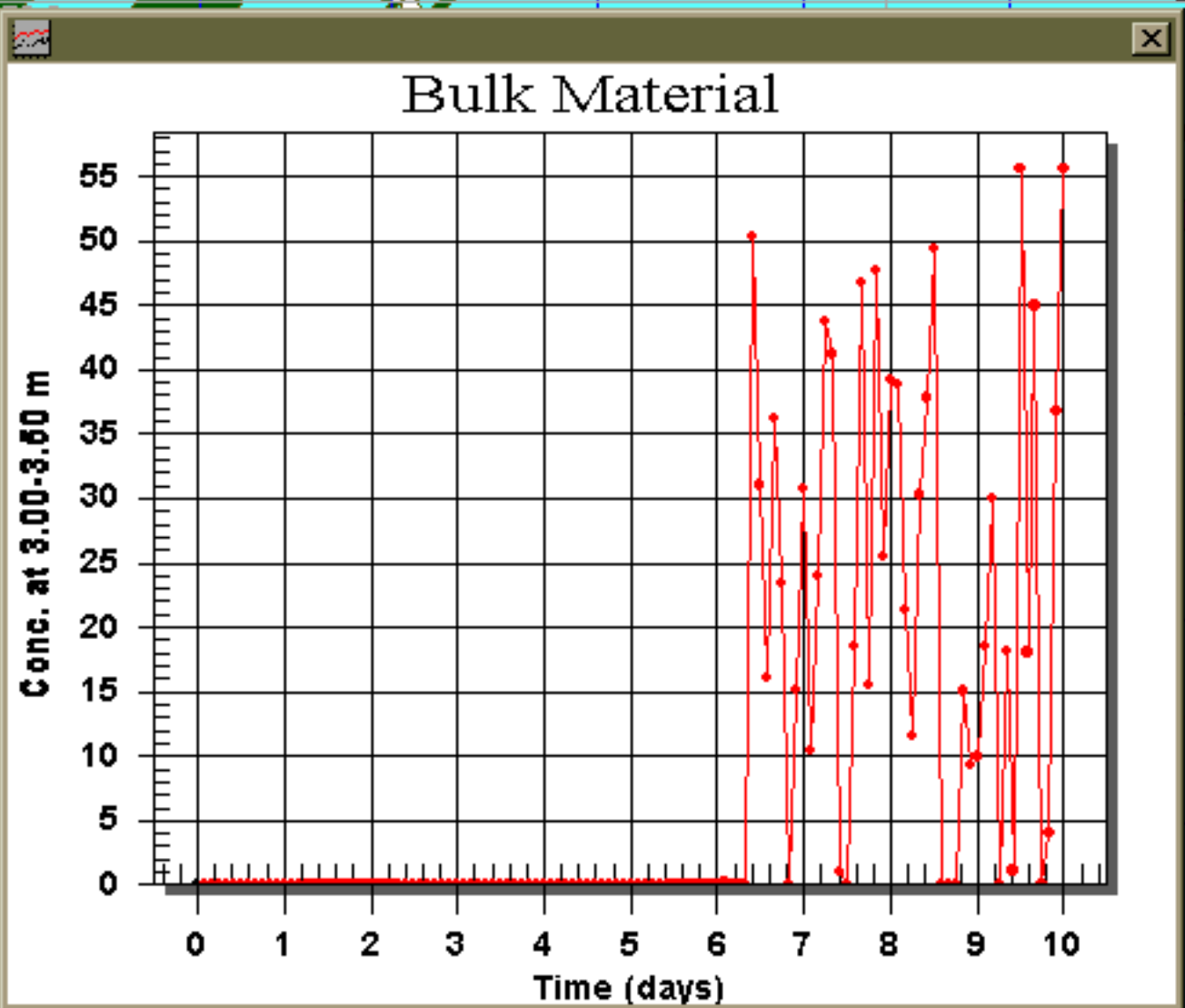

1.5 km
0.8 Nm

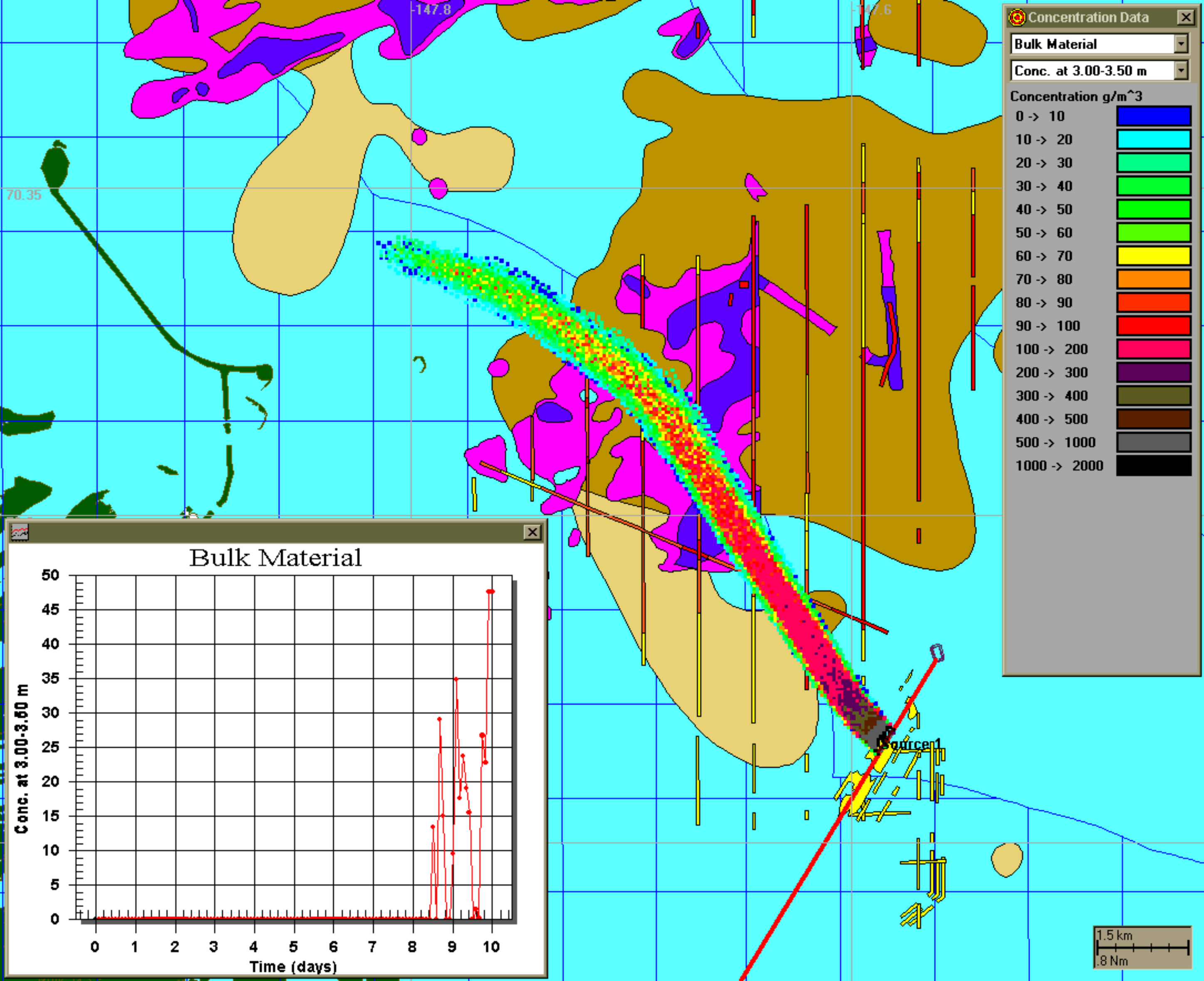

Concentration Data

Bulk Material

Conc. at 3.00-3.50 m

Concentration g/m³

0 -> 10	Blue
10 -> 20	Cyan
20 -> 30	Light Green
30 -> 40	Green
40 -> 50	Bright Green
50 -> 60	Yellow-Green
60 -> 70	Yellow
70 -> 80	Orange
80 -> 90	Red-Orange
90 -> 100	Red
100 -> 200	Magenta
200 -> 300	Purple
300 -> 400	Olive
400 -> 500	Brown
500 -> 1000	Grey
1000 -> 2000	Black

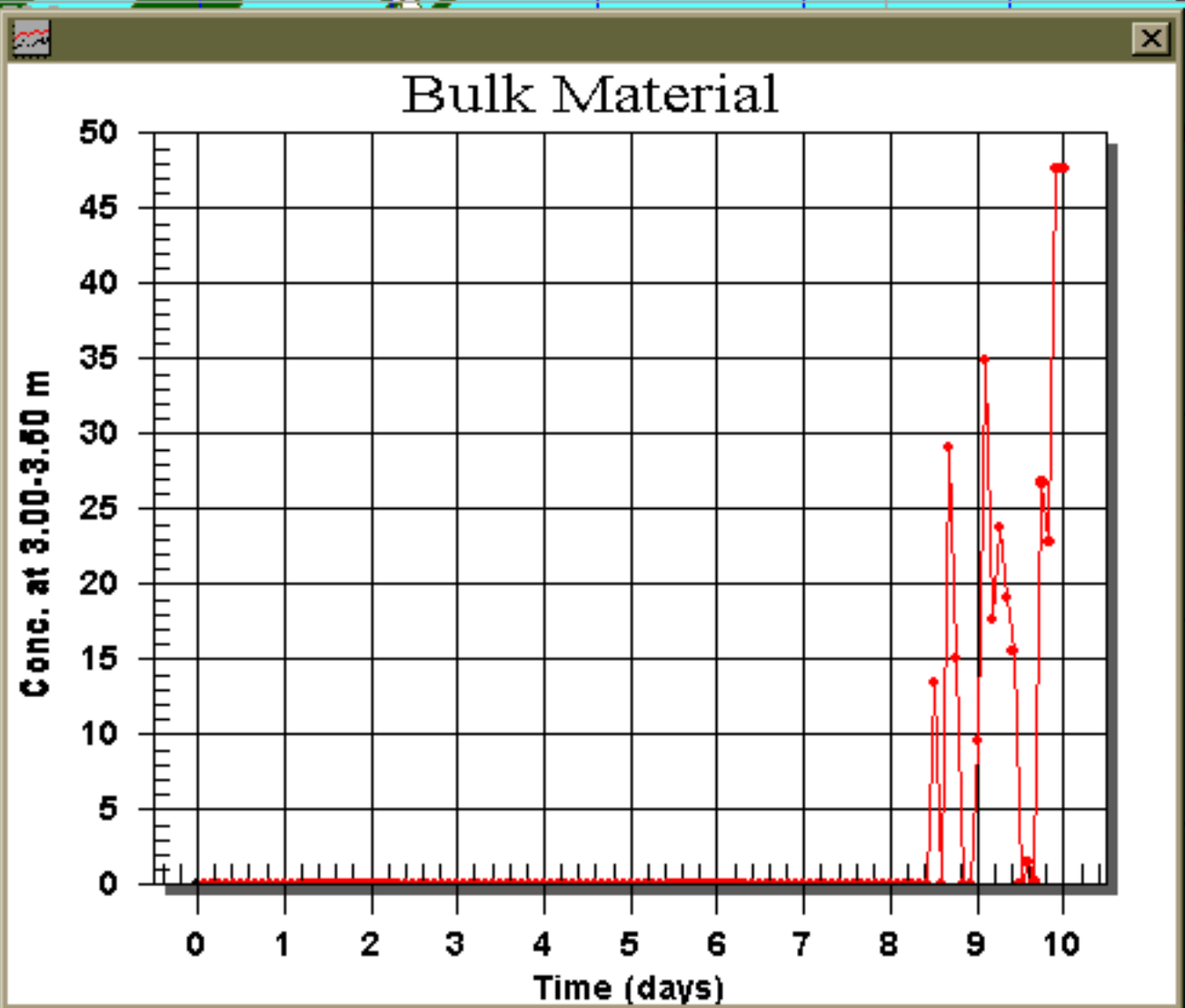

1.5 km
0.8 Nm

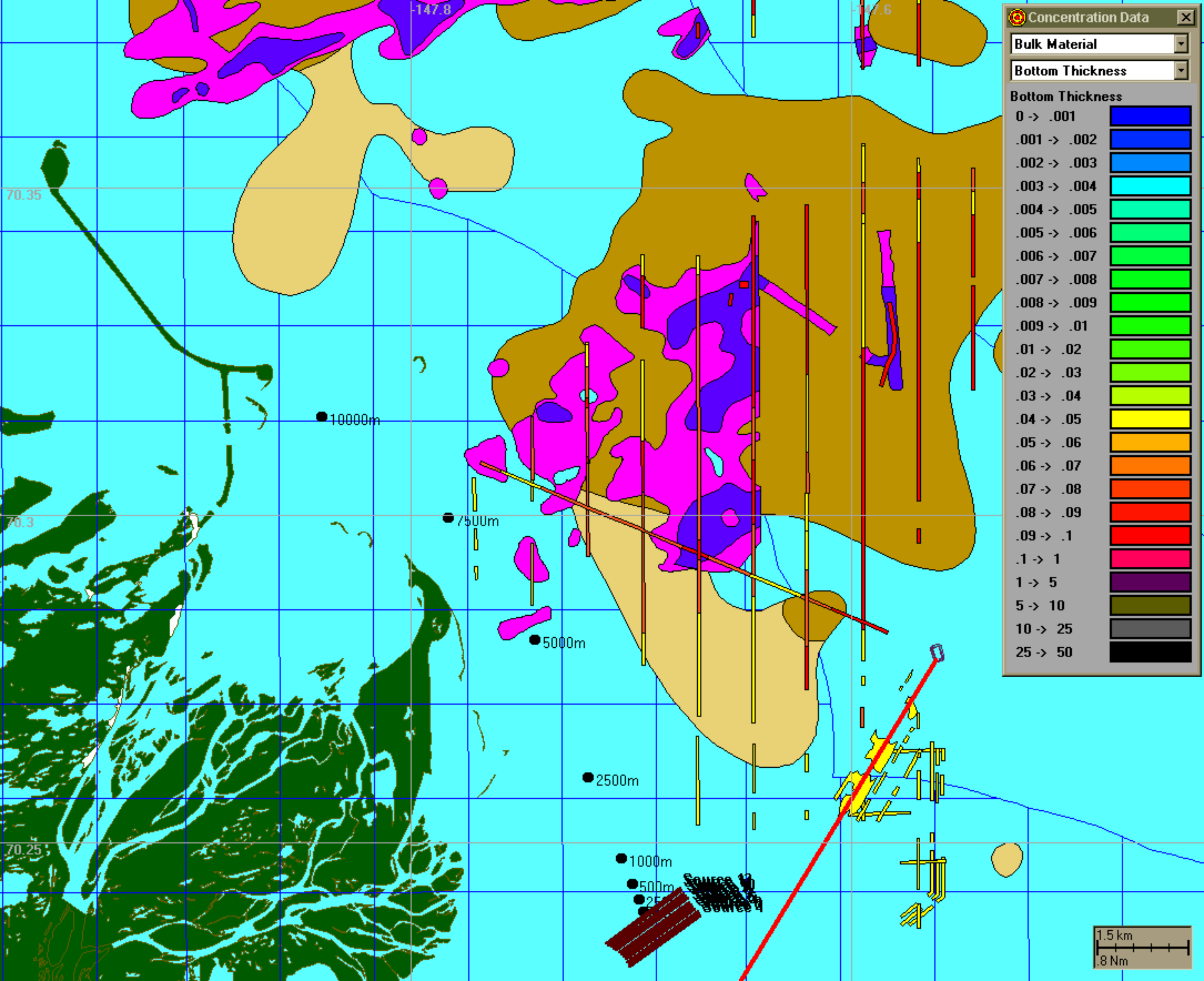

Concentration Data

Bulk Material

Bottom Thickness

Bottom Thickness

0 -> .001	[Dark Blue]
.001 -> .002	[Blue]
.002 -> .003	[Light Blue]
.003 -> .004	[Cyan]
.004 -> .005	[Green-Cyan]
.005 -> .006	[Green]
.006 -> .007	[Light Green]
.007 -> .008	[Green]
.008 -> .009	[Light Green]
.009 -> .01	[Green]
.01 -> .02	[Light Green]
.02 -> .03	[Yellow-Green]
.03 -> .04	[Yellow]
.04 -> .05	[Light Yellow]
.05 -> .06	[Yellow-Orange]
.06 -> .07	[Orange]
.07 -> .08	[Red-Orange]
.08 -> .09	[Red]
.09 -> .1	[Dark Red]
.1 -> 1	[Magenta]
1 -> 5	[Purple]
5 -> 10	[Dark Purple]
10 -> 25	[Black]
25 -> 50	[Dark Grey]

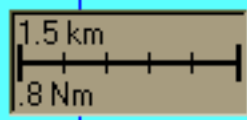

1000m
500m
250m
SOMEGA 12
SOMEGA 4

10000m

7500m

5000m

2500m

1000m

500m

250m

147.8

147.6

70.35

70.3

70.25

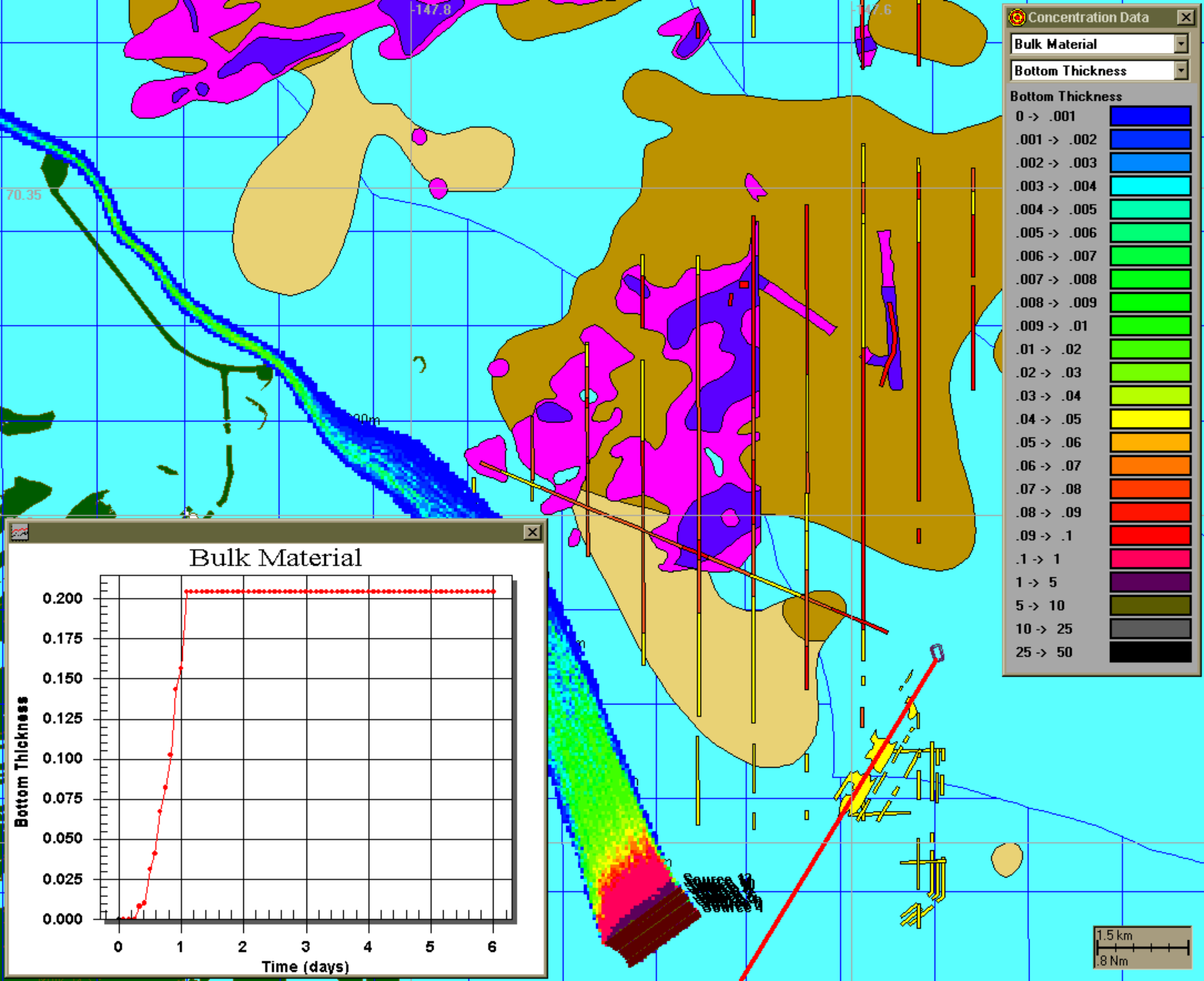

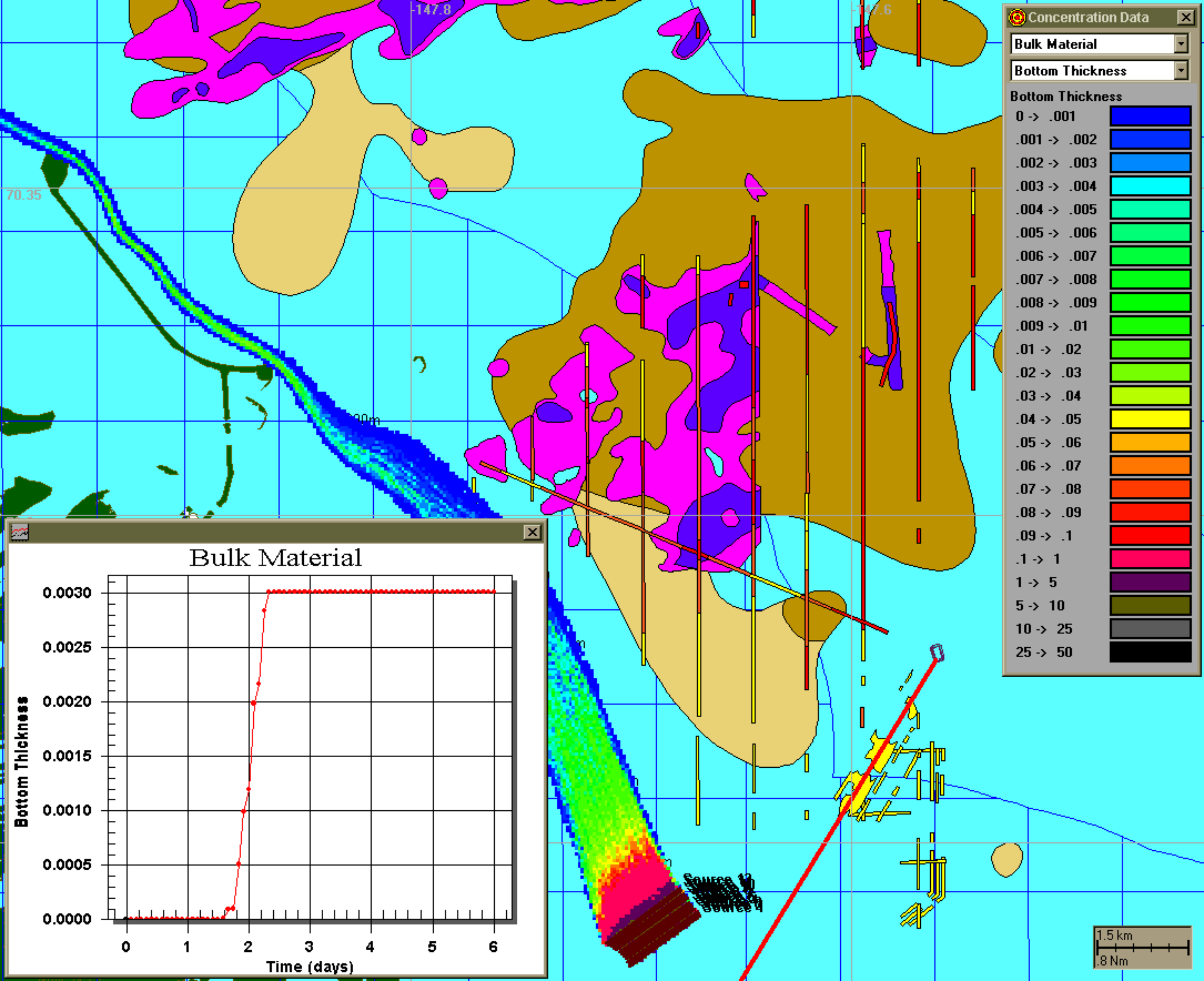

Concentration Data

Bulk Material

Bottom Thickness

Bottom Thickness

0 -> .001	[Dark Blue]
.001 -> .002	[Blue]
.002 -> .003	[Light Blue]
.003 -> .004	[Cyan]
.004 -> .005	[Green-Cyan]
.005 -> .006	[Green]
.006 -> .007	[Light Green]
.007 -> .008	[Green]
.008 -> .009	[Light Green]
.009 -> .01	[Green]
.01 -> .02	[Light Green]
.02 -> .03	[Yellow-Green]
.03 -> .04	[Yellow]
.04 -> .05	[Light Yellow]
.05 -> .06	[Orange-Yellow]
.06 -> .07	[Orange]
.07 -> .08	[Red-Orange]
.08 -> .09	[Red]
.09 -> .1	[Dark Red]
.1 -> 1	[Magenta]
1 -> 5	[Purple]
5 -> 10	[Dark Purple]
10 -> 25	[Black-Gray]
25 -> 50	[Black]

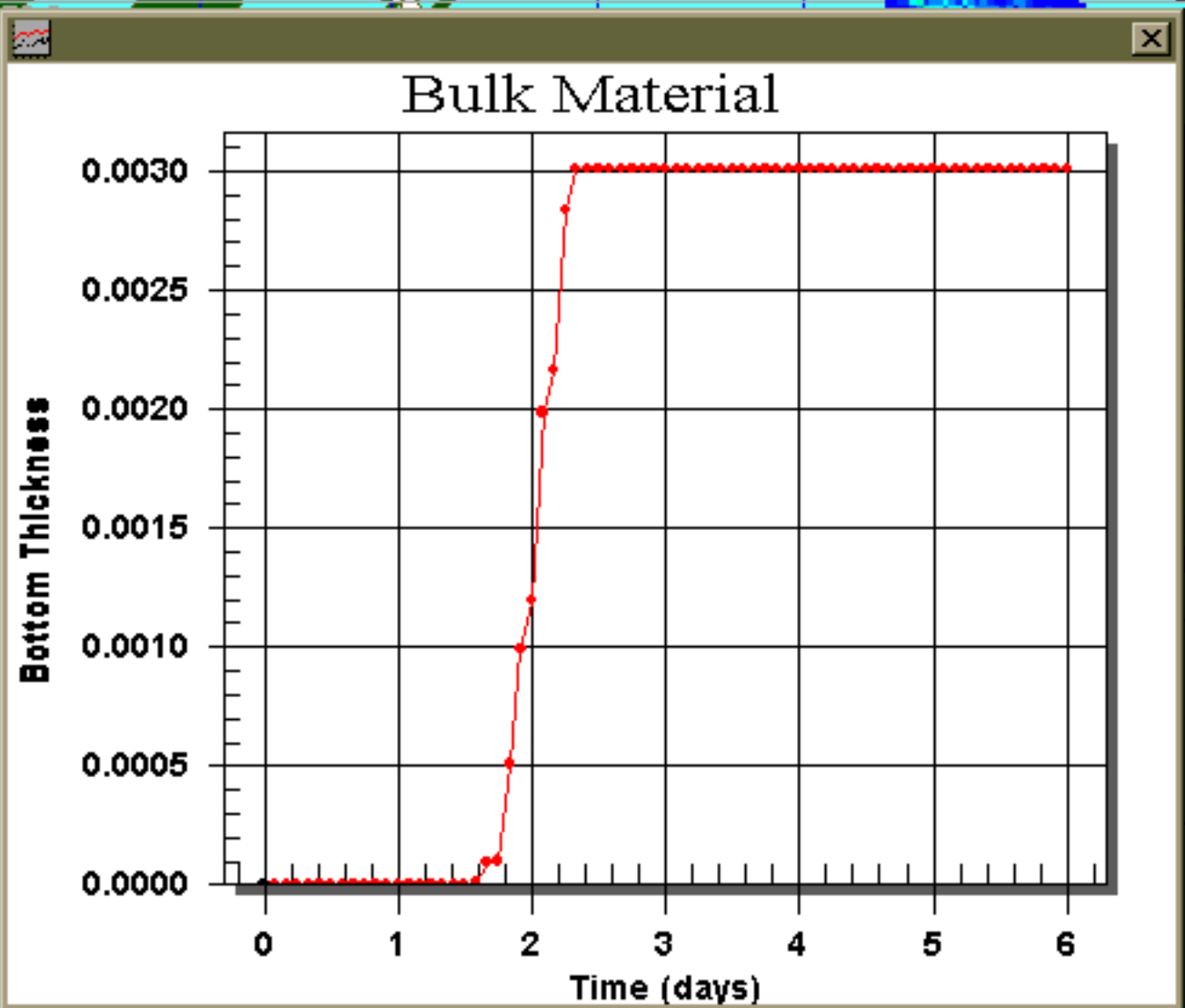

1.5 km
.8 Nm

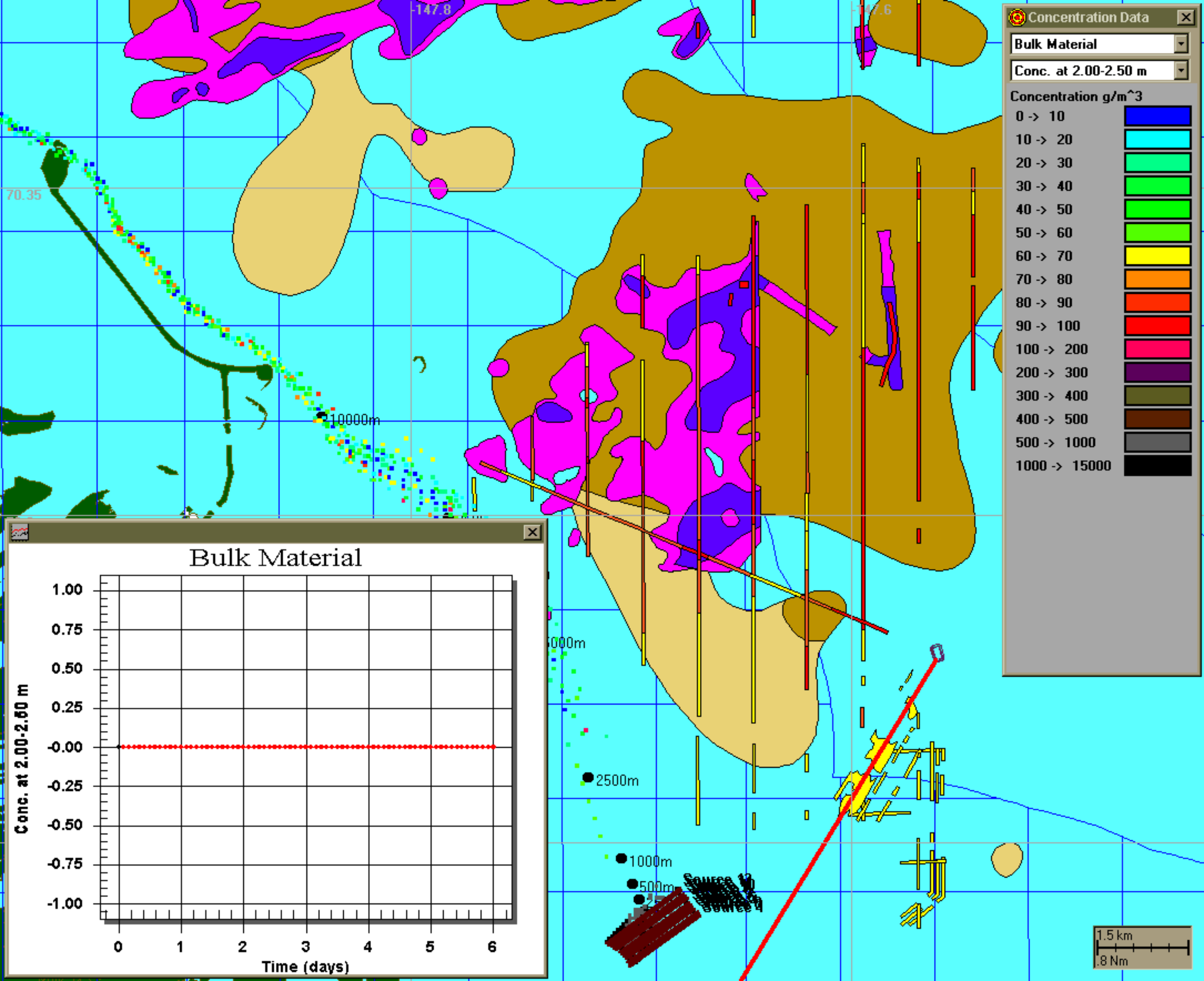

Concentration Data

Bulk Material

Conc. at 2.00-2.50 m

Concentration g/m³

0 -> 10	Blue
10 -> 20	Cyan
20 -> 30	Light Green
30 -> 40	Green
40 -> 50	Bright Green
50 -> 60	Yellow-Green
60 -> 70	Yellow
70 -> 80	Orange
80 -> 90	Red-Orange
90 -> 100	Red
100 -> 200	Magenta
200 -> 300	Purple
300 -> 400	Olive
400 -> 500	Brown
500 -> 1000	Grey
1000 -> 15000	Black

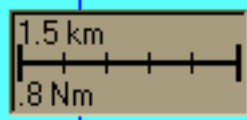
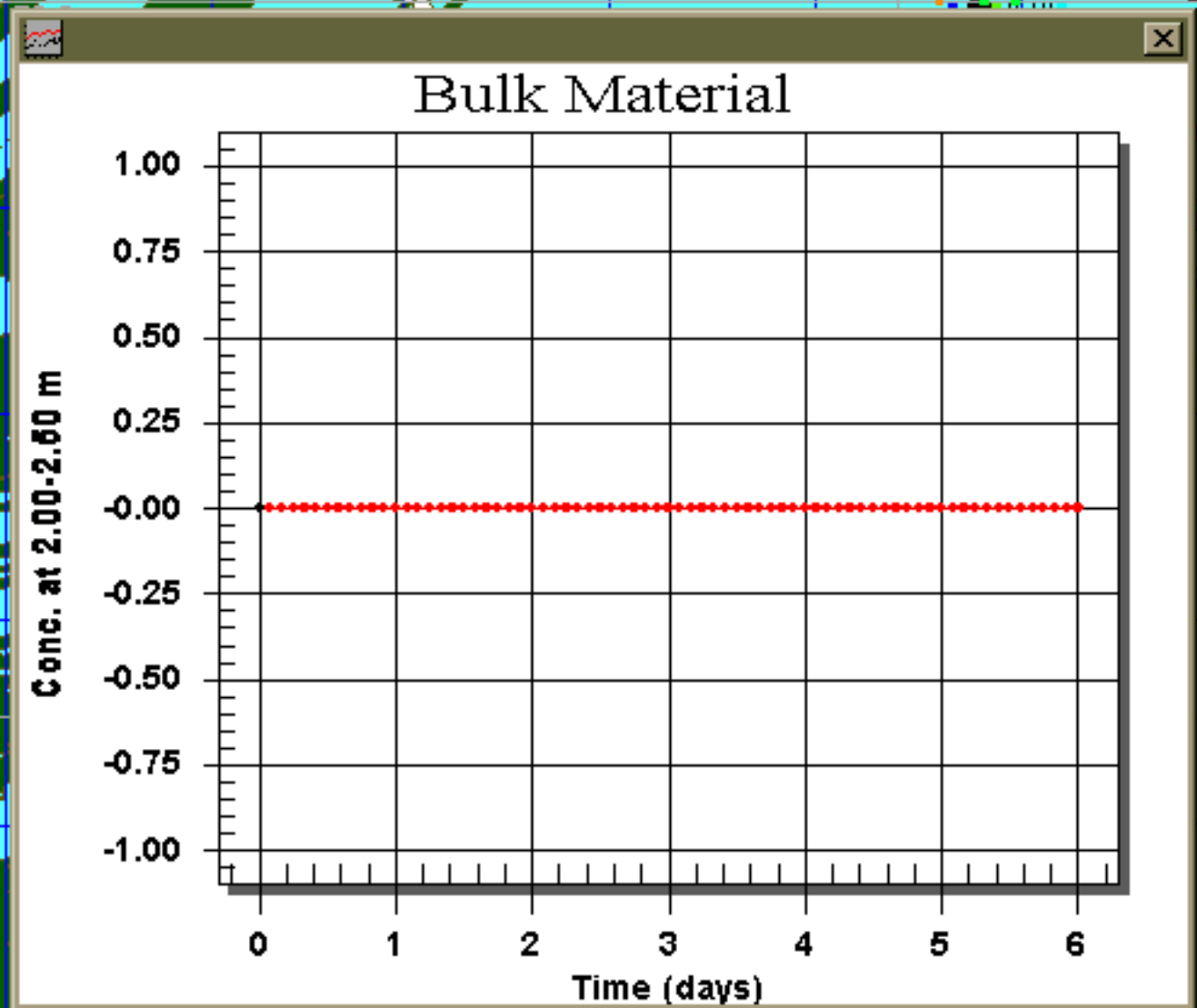

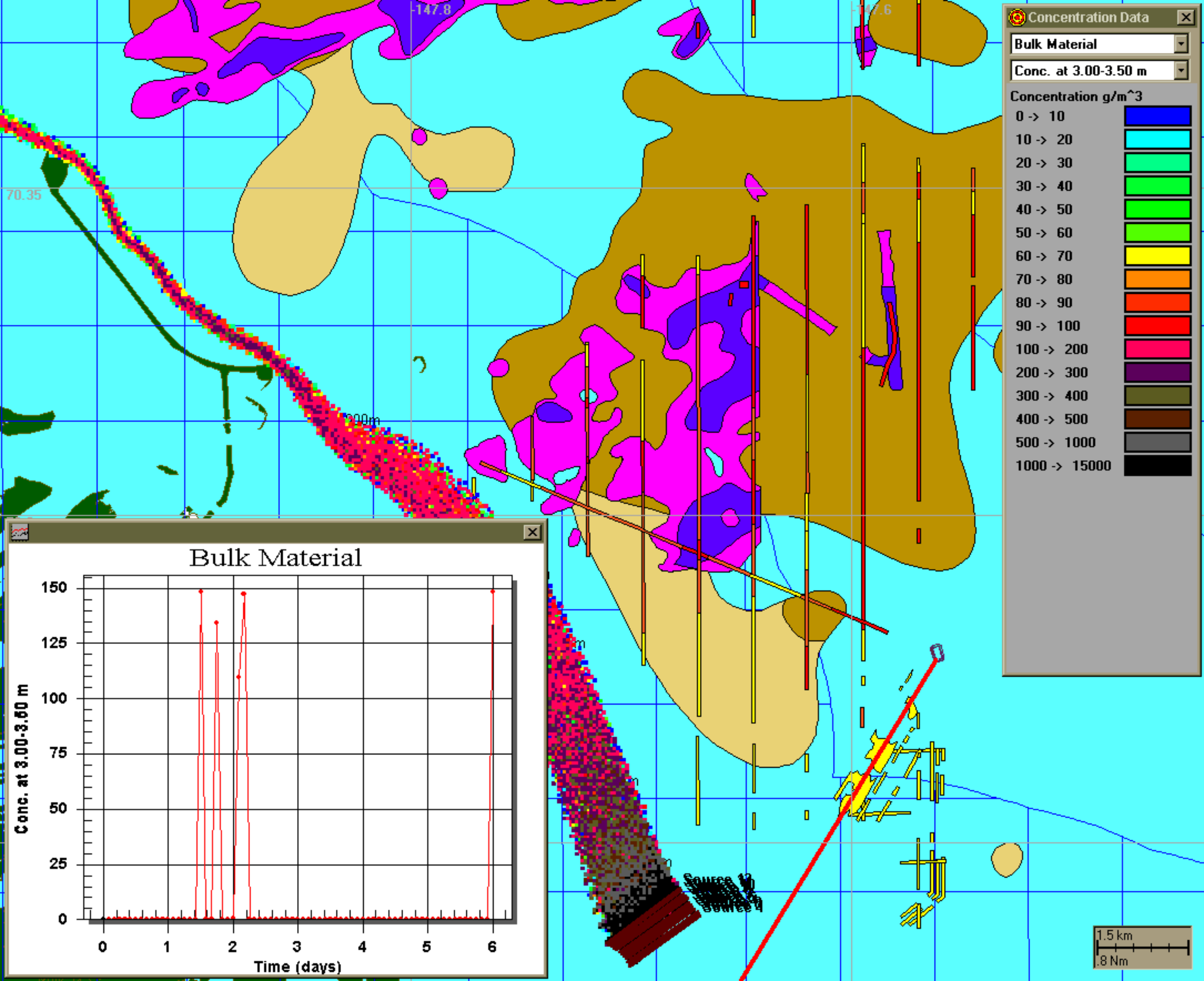

Bulk Material

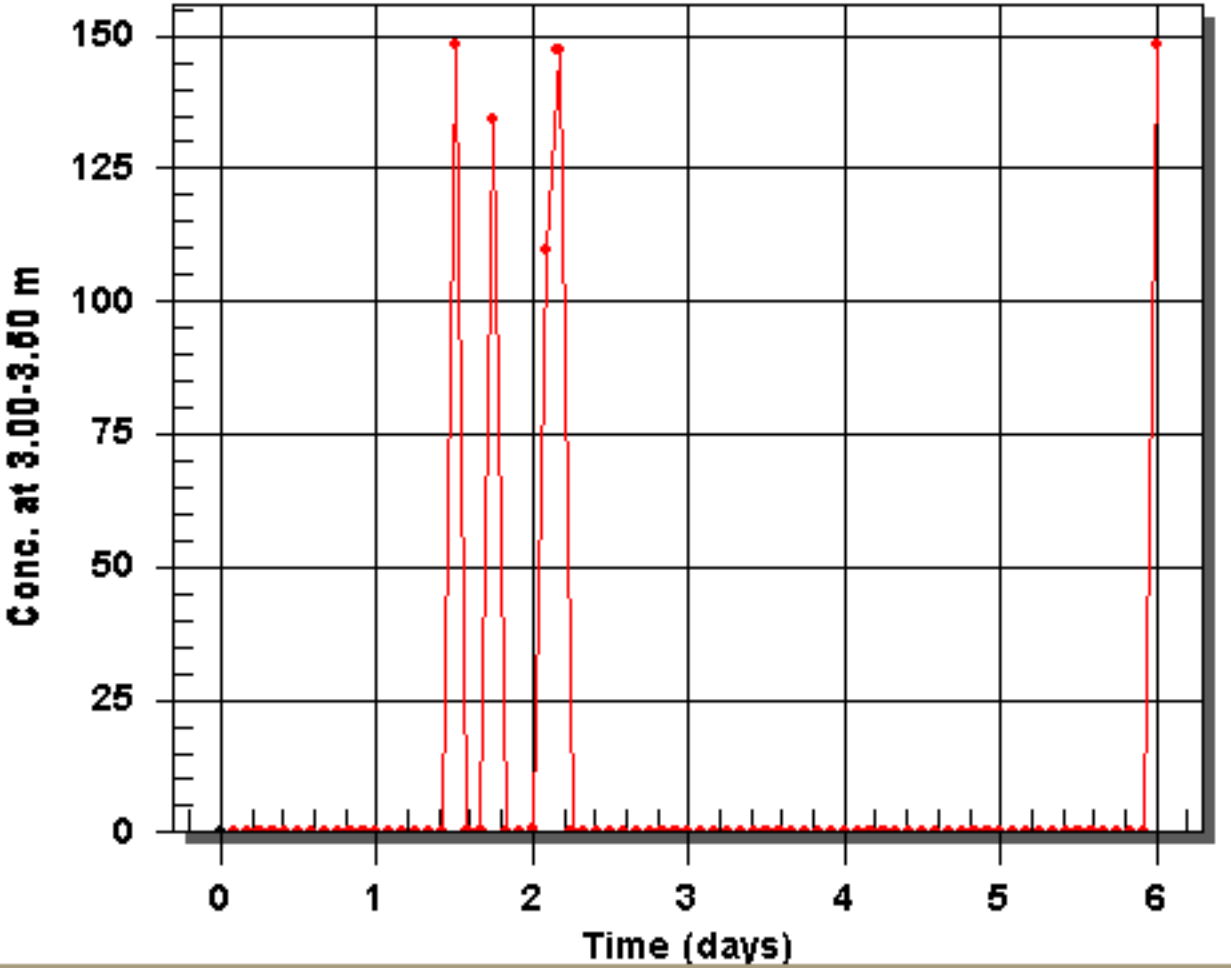

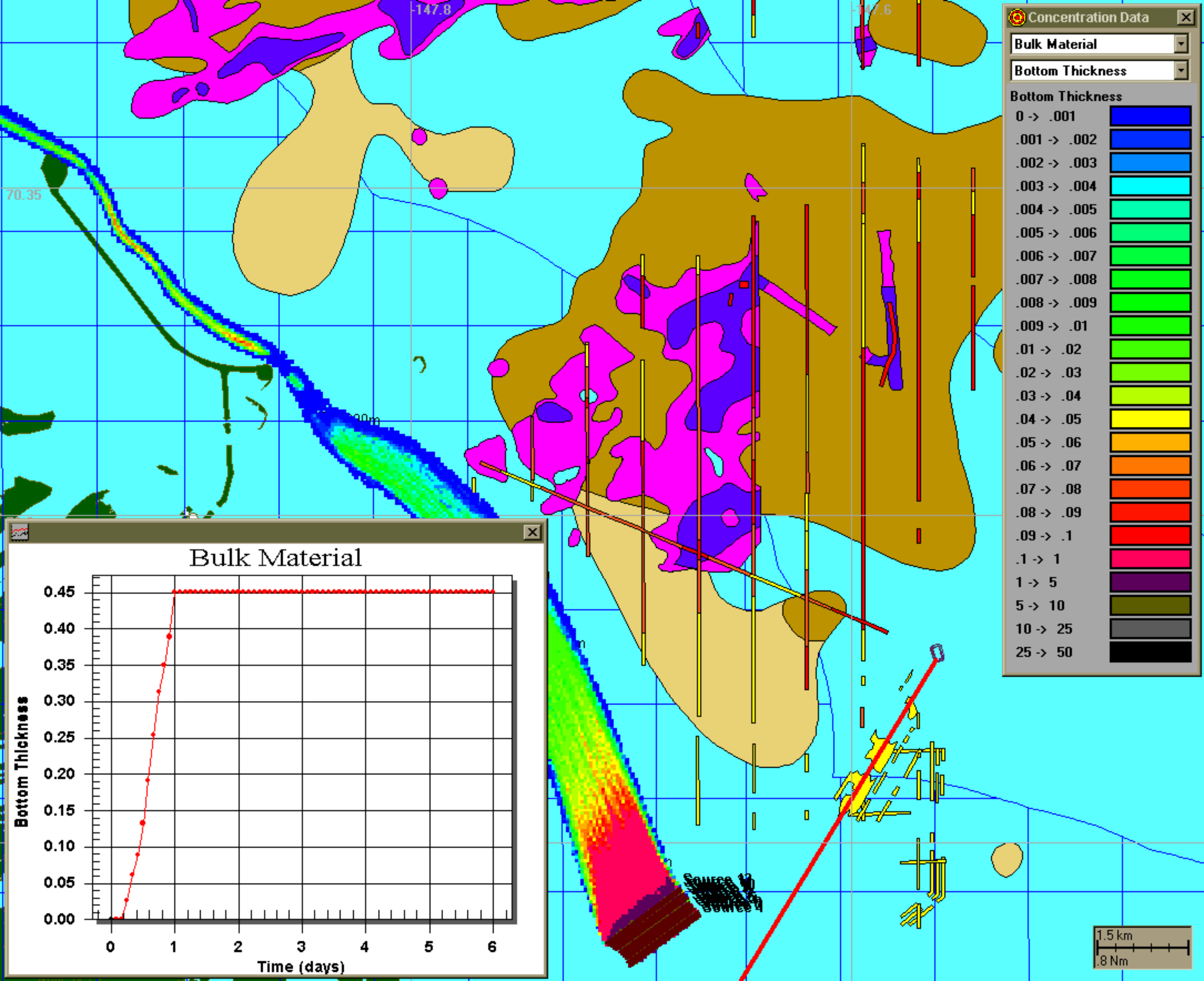

Concentration Data

Bulk Material

Bottom Thickness

Bottom Thickness

0 -> .001	[Dark Blue]
.001 -> .002	[Blue]
.002 -> .003	[Light Blue]
.003 -> .004	[Cyan]
.004 -> .005	[Green-Cyan]
.005 -> .006	[Green]
.006 -> .007	[Light Green]
.007 -> .008	[Green]
.008 -> .009	[Light Green]
.009 -> .01	[Green]
.01 -> .02	[Light Green]
.02 -> .03	[Yellow-Green]
.03 -> .04	[Yellow]
.04 -> .05	[Light Yellow]
.05 -> .06	[Orange]
.06 -> .07	[Red-Orange]
.07 -> .08	[Red]
.08 -> .09	[Dark Red]
.09 -> .1	[Red]
.1 -> 1	[Magenta]
1 -> 5	[Purple]
5 -> 10	[Dark Purple]
10 -> 25	[Black-Gray]
25 -> 50	[Black]

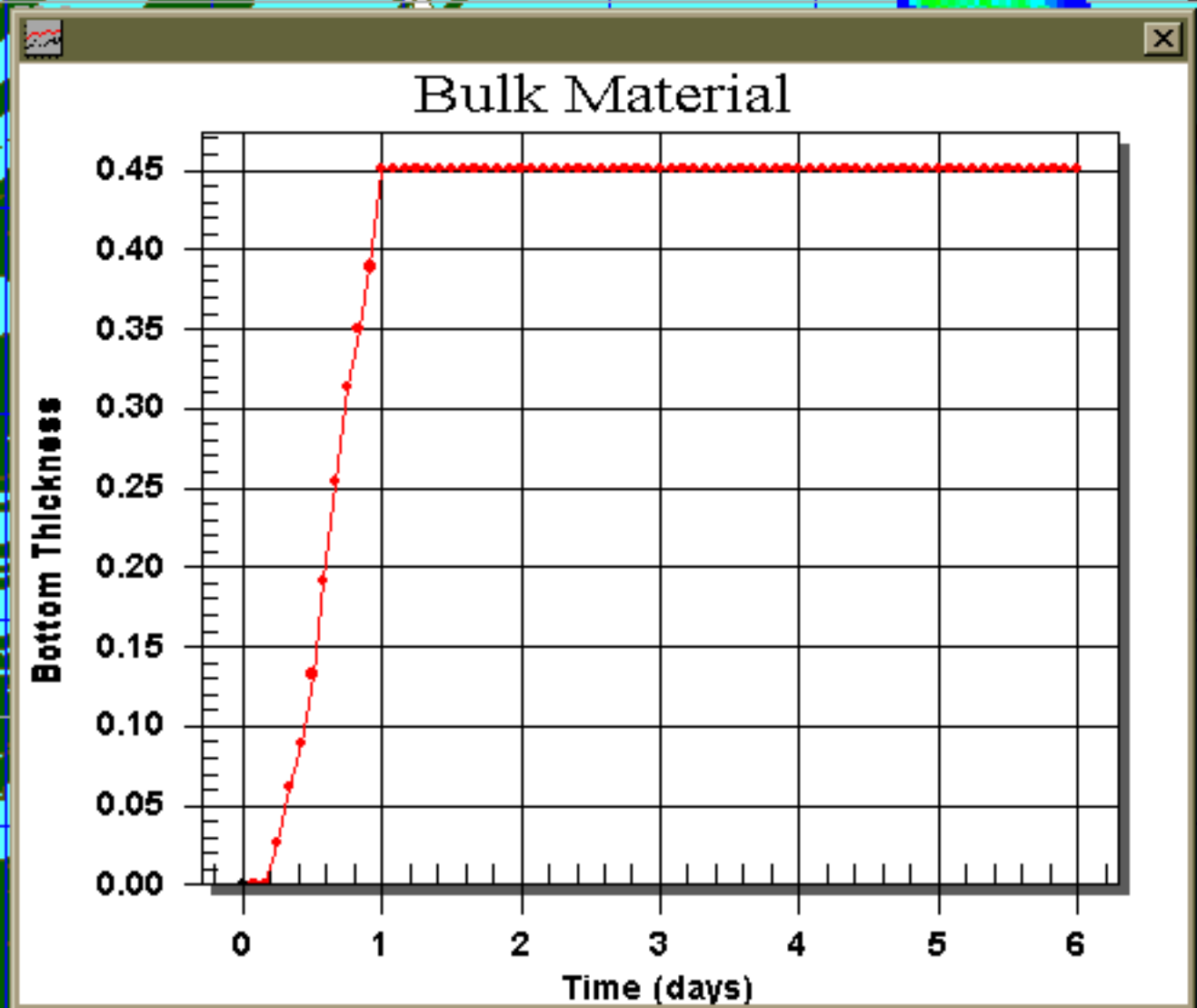

1.5 km
0.8 Nm

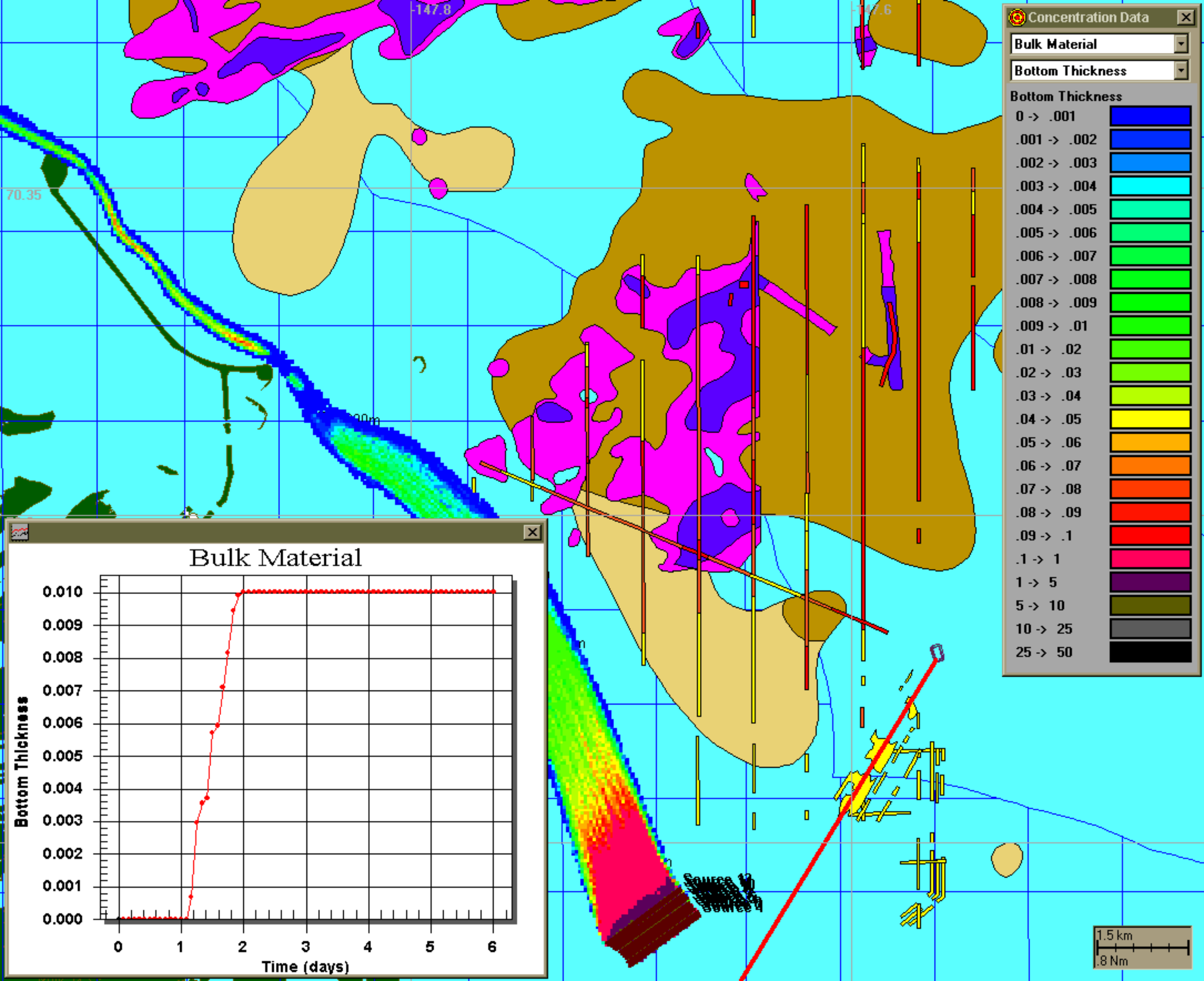

Concentration Data

Bulk Material

Bottom Thickness

Bottom Thickness

0 -> .001	[Color swatch]
.001 -> .002	[Color swatch]
.002 -> .003	[Color swatch]
.003 -> .004	[Color swatch]
.004 -> .005	[Color swatch]
.005 -> .006	[Color swatch]
.006 -> .007	[Color swatch]
.007 -> .008	[Color swatch]
.008 -> .009	[Color swatch]
.009 -> .01	[Color swatch]
.01 -> .02	[Color swatch]
.02 -> .03	[Color swatch]
.03 -> .04	[Color swatch]
.04 -> .05	[Color swatch]
.05 -> .06	[Color swatch]
.06 -> .07	[Color swatch]
.07 -> .08	[Color swatch]
.08 -> .09	[Color swatch]
.09 -> .1	[Color swatch]
.1 -> 1	[Color swatch]
1 -> 5	[Color swatch]
5 -> 10	[Color swatch]
10 -> 25	[Color swatch]
25 -> 50	[Color swatch]

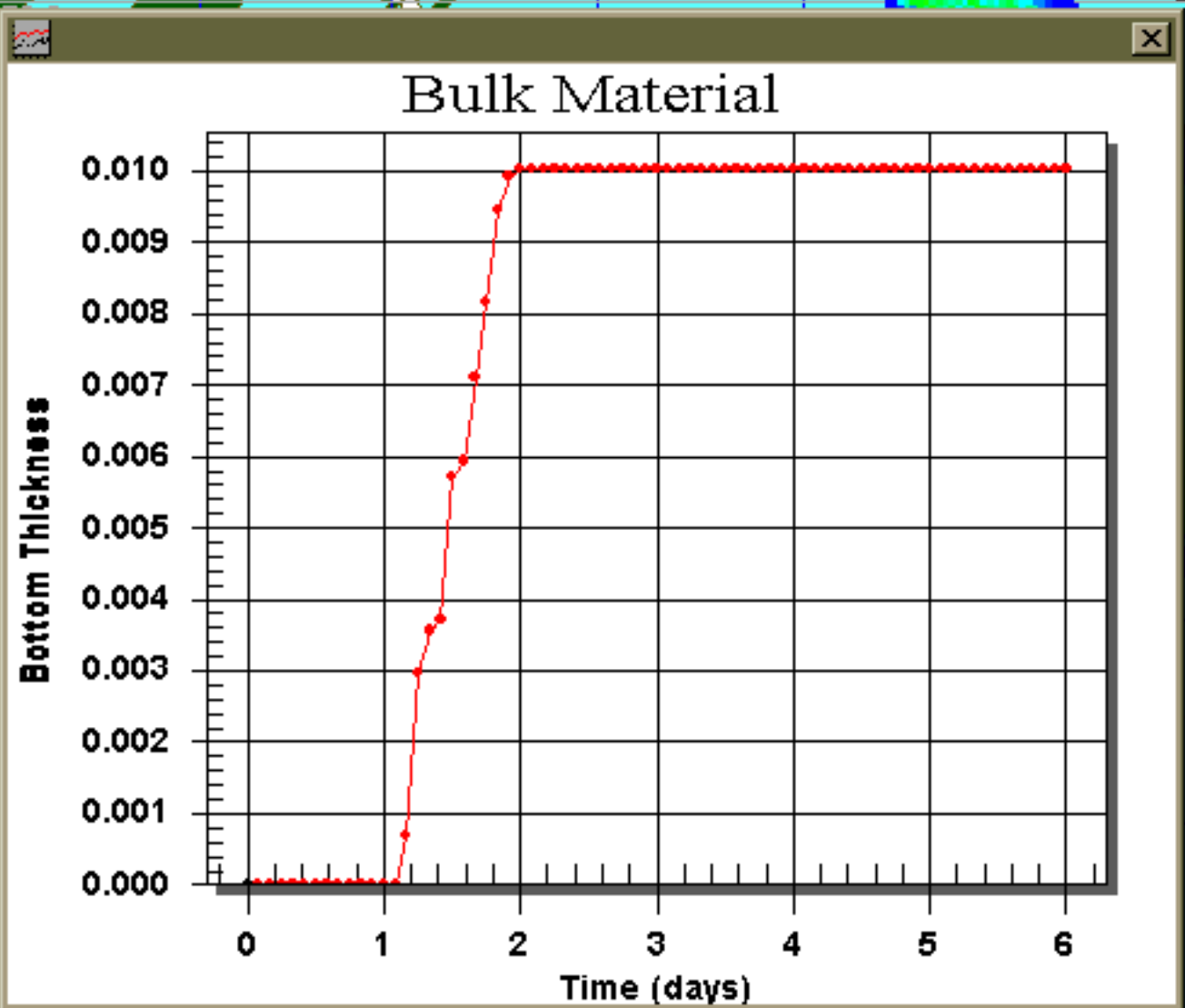

1.5 km
0.8 Nm

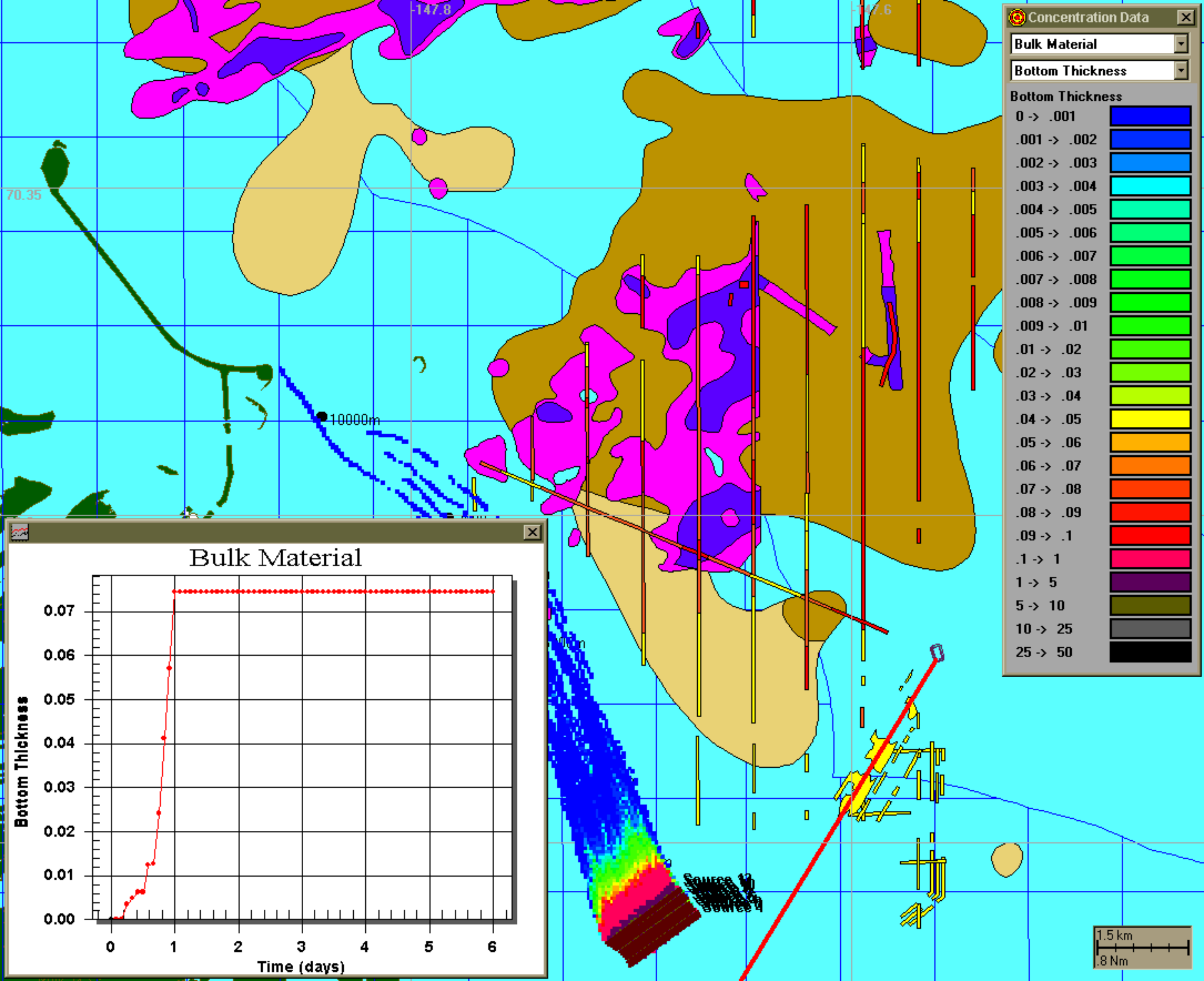

Concentration Data

Bulk Material

Bottom Thickness

Bottom Thickness

0 -> .001	[Dark Blue]
.001 -> .002	[Blue]
.002 -> .003	[Light Blue]
.003 -> .004	[Cyan]
.004 -> .005	[Green-Cyan]
.005 -> .006	[Green]
.006 -> .007	[Light Green]
.007 -> .008	[Green]
.008 -> .009	[Light Green]
.009 -> .01	[Green]
.01 -> .02	[Light Green]
.02 -> .03	[Yellow-Green]
.03 -> .04	[Yellow]
.04 -> .05	[Light Orange]
.05 -> .06	[Orange]
.06 -> .07	[Red-Orange]
.07 -> .08	[Red]
.08 -> .09	[Dark Red]
.09 -> .1	[Red]
.1 -> 1	[Magenta]
1 -> 5	[Purple]
5 -> 10	[Olive Green]
10 -> 25	[Grey]
25 -> 50	[Black]

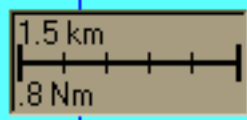
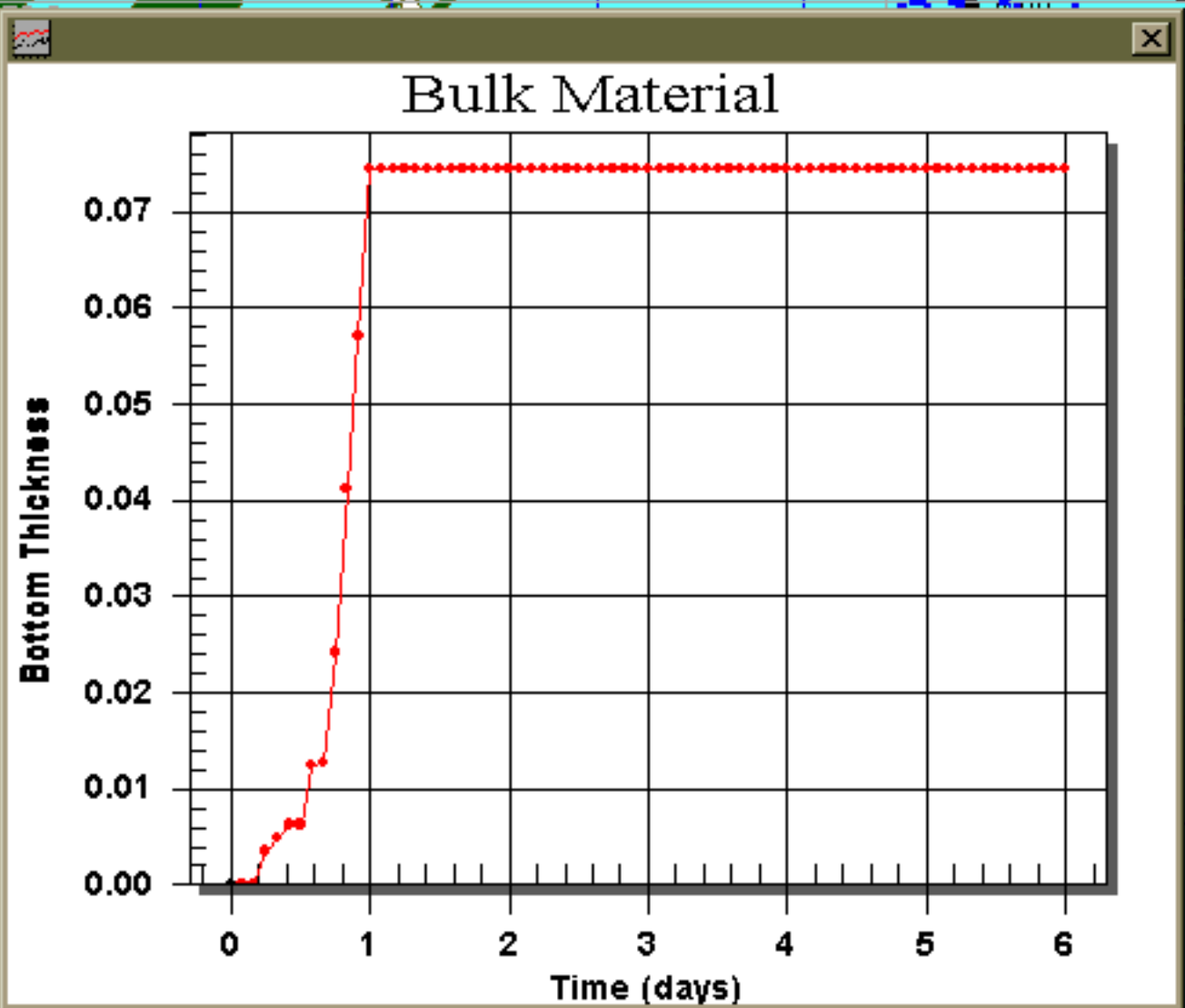

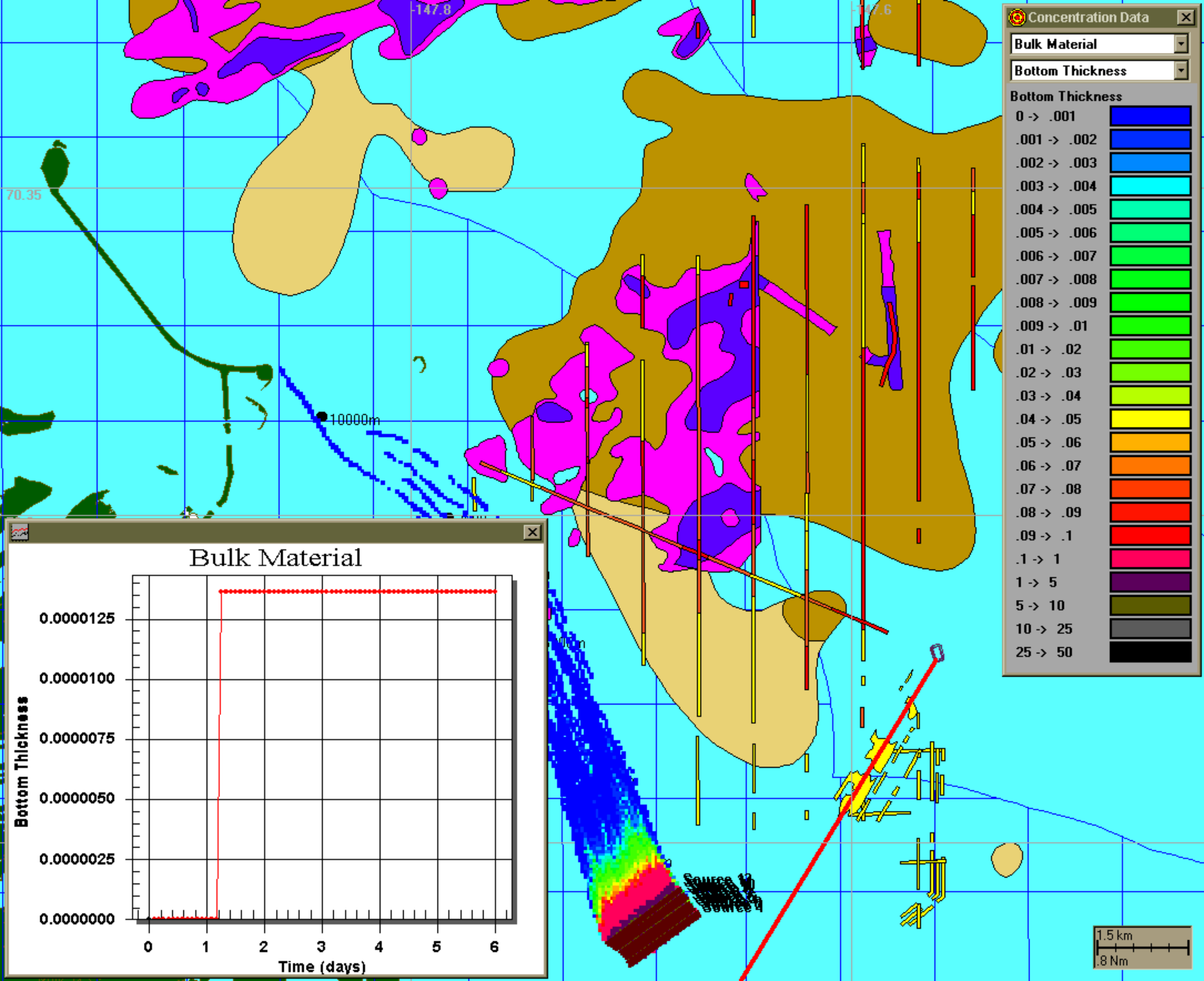

Concentration Data

Bulk Material

Bottom Thickness

Bottom Thickness

- 0 -> .001
- .001 -> .002
- .002 -> .003
- .003 -> .004
- .004 -> .005
- .005 -> .006
- .006 -> .007
- .007 -> .008
- .008 -> .009
- .009 -> .01
- .01 -> .02
- .02 -> .03
- .03 -> .04
- .04 -> .05
- .05 -> .06
- .06 -> .07
- .07 -> .08
- .08 -> .09
- .09 -> .1
- .1 -> 1
- 1 -> 5
- 5 -> 10
- 10 -> 25
- 25 -> 50

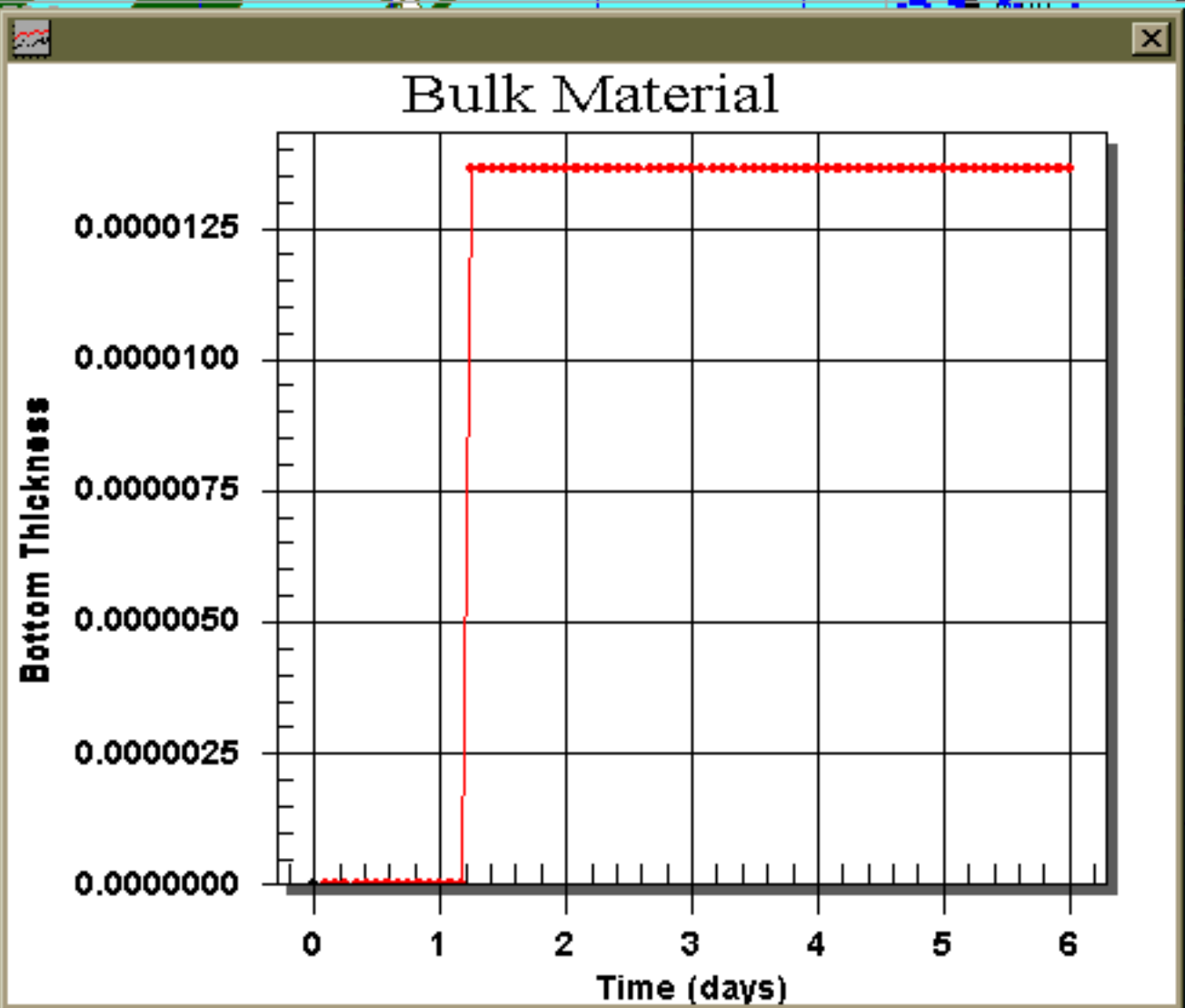

1.5 km
.8 Nm

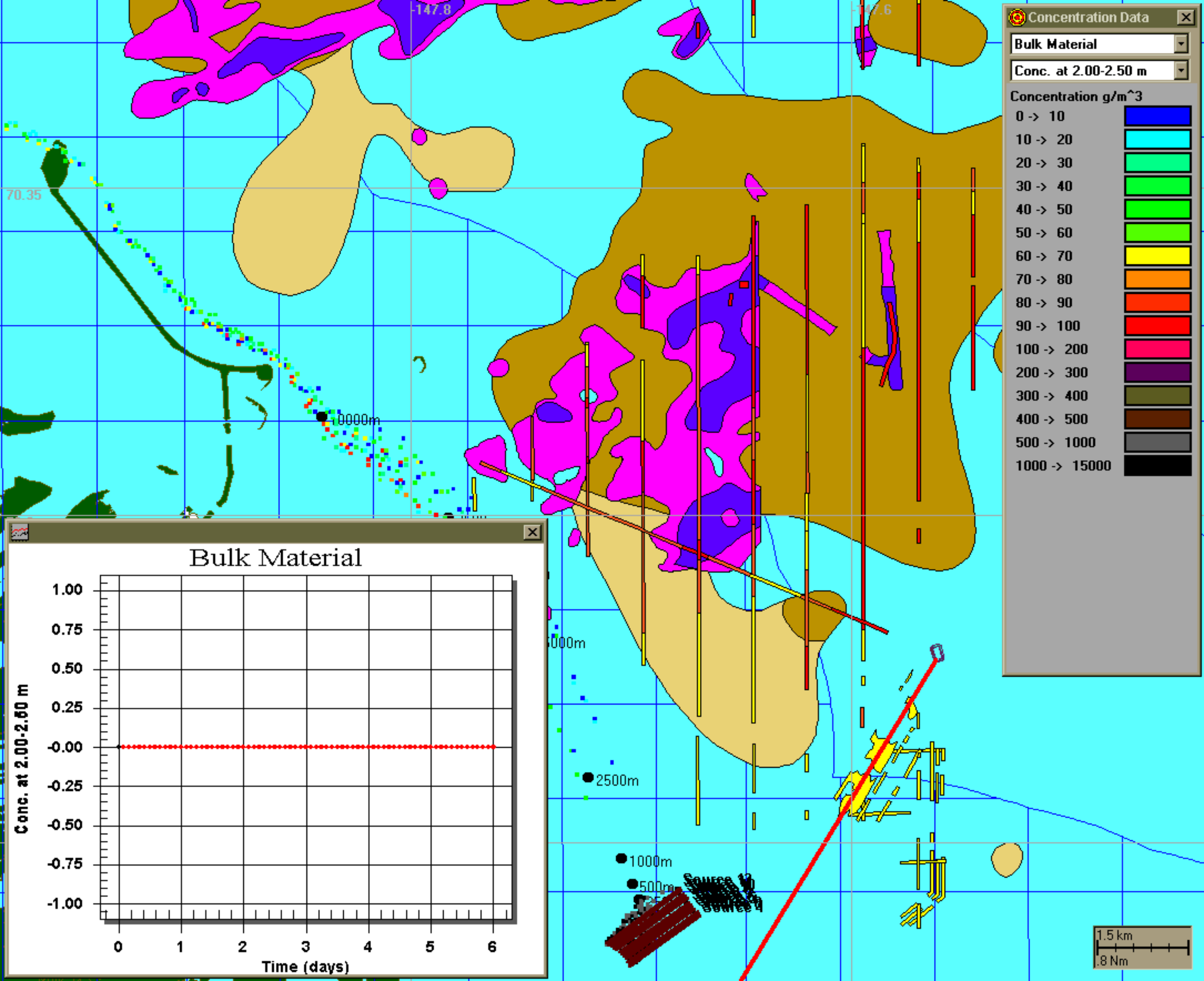

Concentration Data

Bulk Material

Conc. at 2.00-2.50 m

Concentration g/m^3

0 -> 10	Blue
10 -> 20	Cyan
20 -> 30	Light Green
30 -> 40	Green
40 -> 50	Bright Green
50 -> 60	Yellow-Green
60 -> 70	Yellow
70 -> 80	Orange
80 -> 90	Red-Orange
90 -> 100	Red
100 -> 200	Magenta
200 -> 300	Purple
300 -> 400	Olive
400 -> 500	Brown
500 -> 1000	Grey
1000 -> 15000	Black

Bulk Material

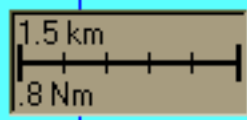
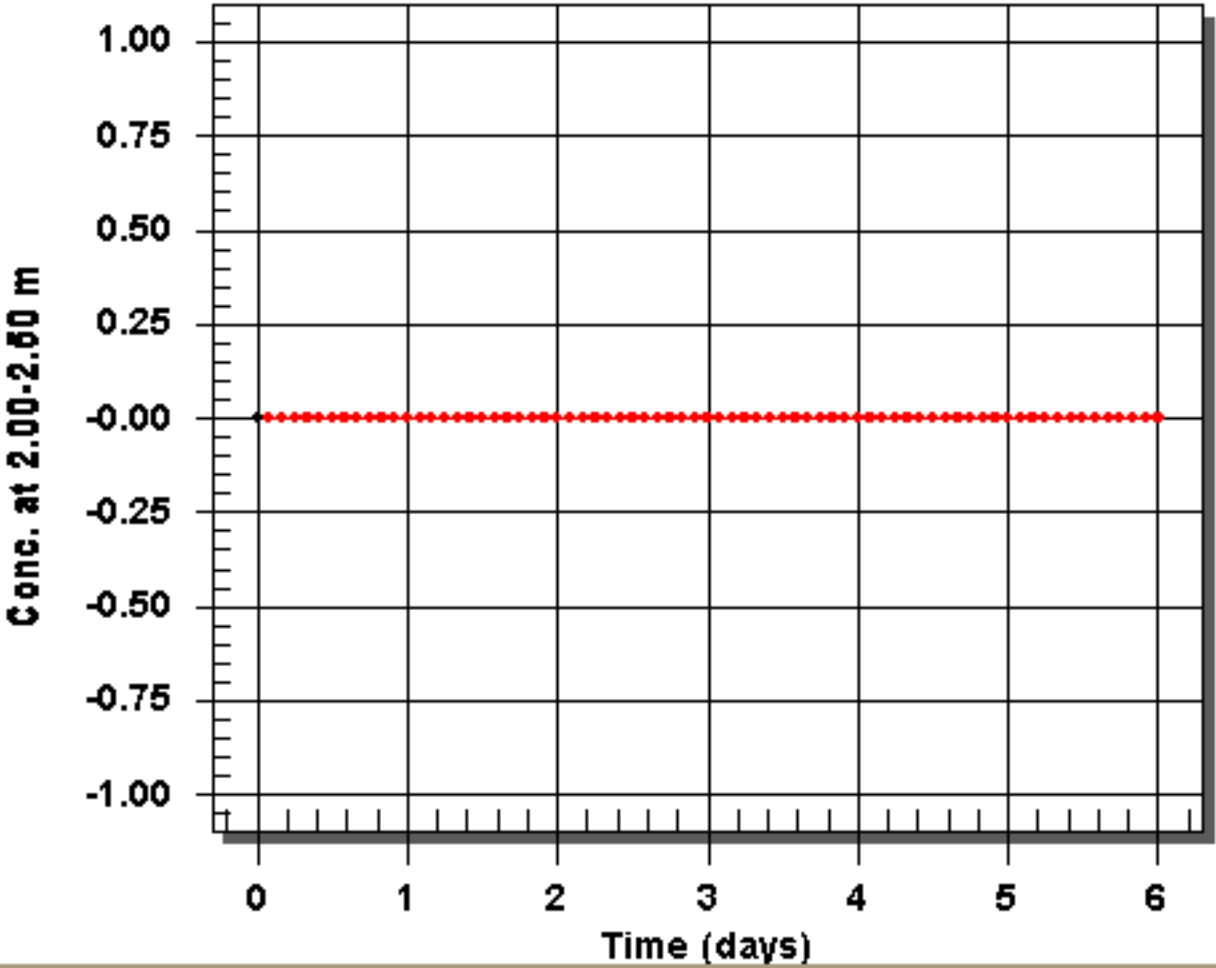

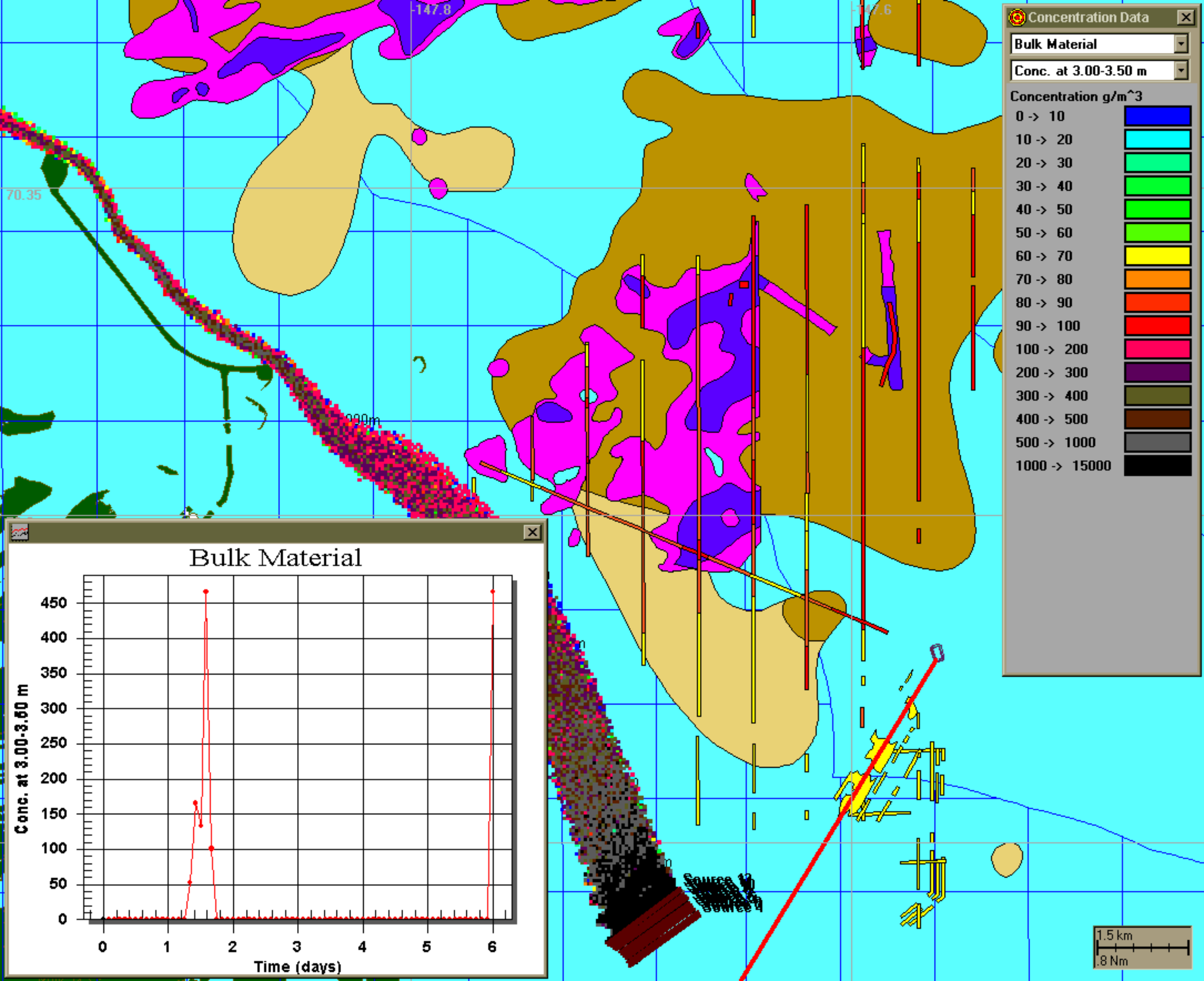

Concentration Data

Bulk Material

Conc. at 3.00-3.50 m

Concentration g/m^3

0 -> 10	Blue
10 -> 20	Cyan
20 -> 30	Light Green
30 -> 40	Green
40 -> 50	Bright Green
50 -> 60	Yellow-Green
60 -> 70	Yellow
70 -> 80	Orange
80 -> 90	Red-Orange
90 -> 100	Red
100 -> 200	Magenta
200 -> 300	Purple
300 -> 400	Olive
400 -> 500	Brown
500 -> 1000	Grey
1000 -> 15000	Black

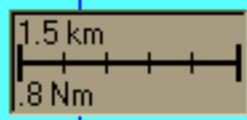
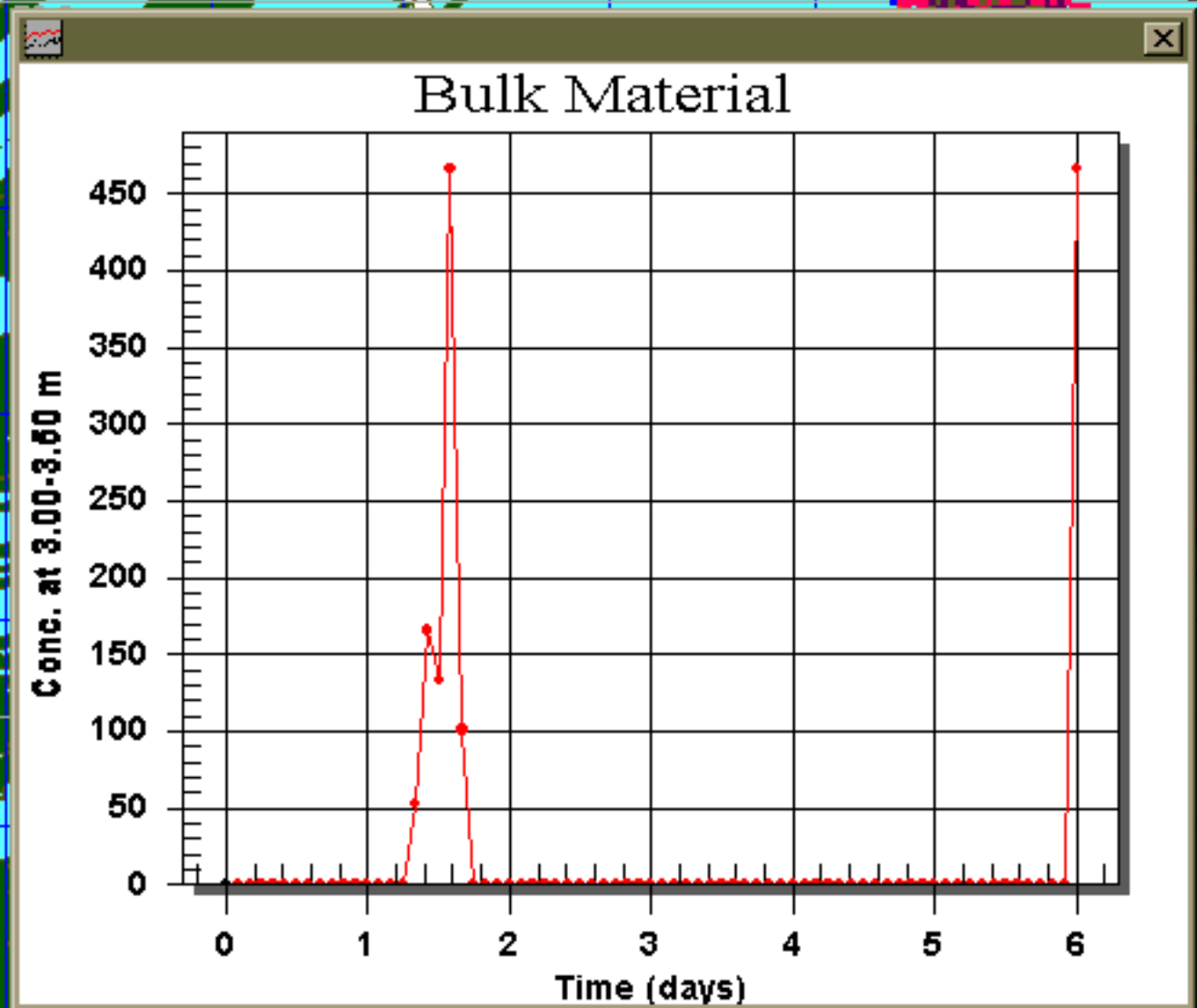

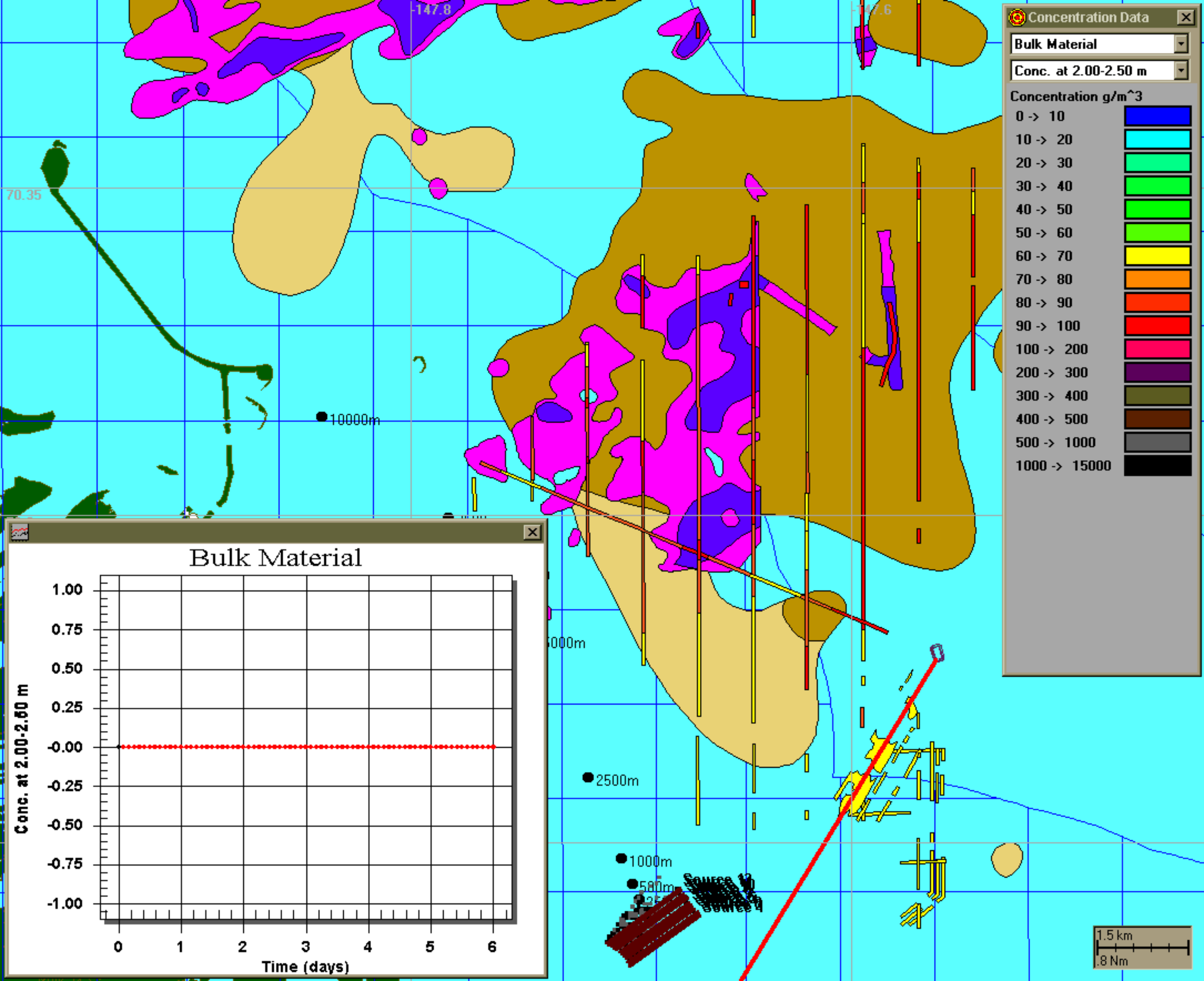

Concentration Data

Bulk Material

Conc. at 2.00-2.50 m

Concentration g/m^3

0 -> 10	Blue
10 -> 20	Cyan
20 -> 30	Light Green
30 -> 40	Green
40 -> 50	Bright Green
50 -> 60	Yellow-Green
60 -> 70	Yellow
70 -> 80	Orange
80 -> 90	Red-Orange
90 -> 100	Red
100 -> 200	Magenta
200 -> 300	Purple
300 -> 400	Olive
400 -> 500	Brown
500 -> 1000	Grey
1000 -> 15000	Black

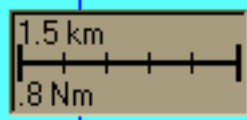
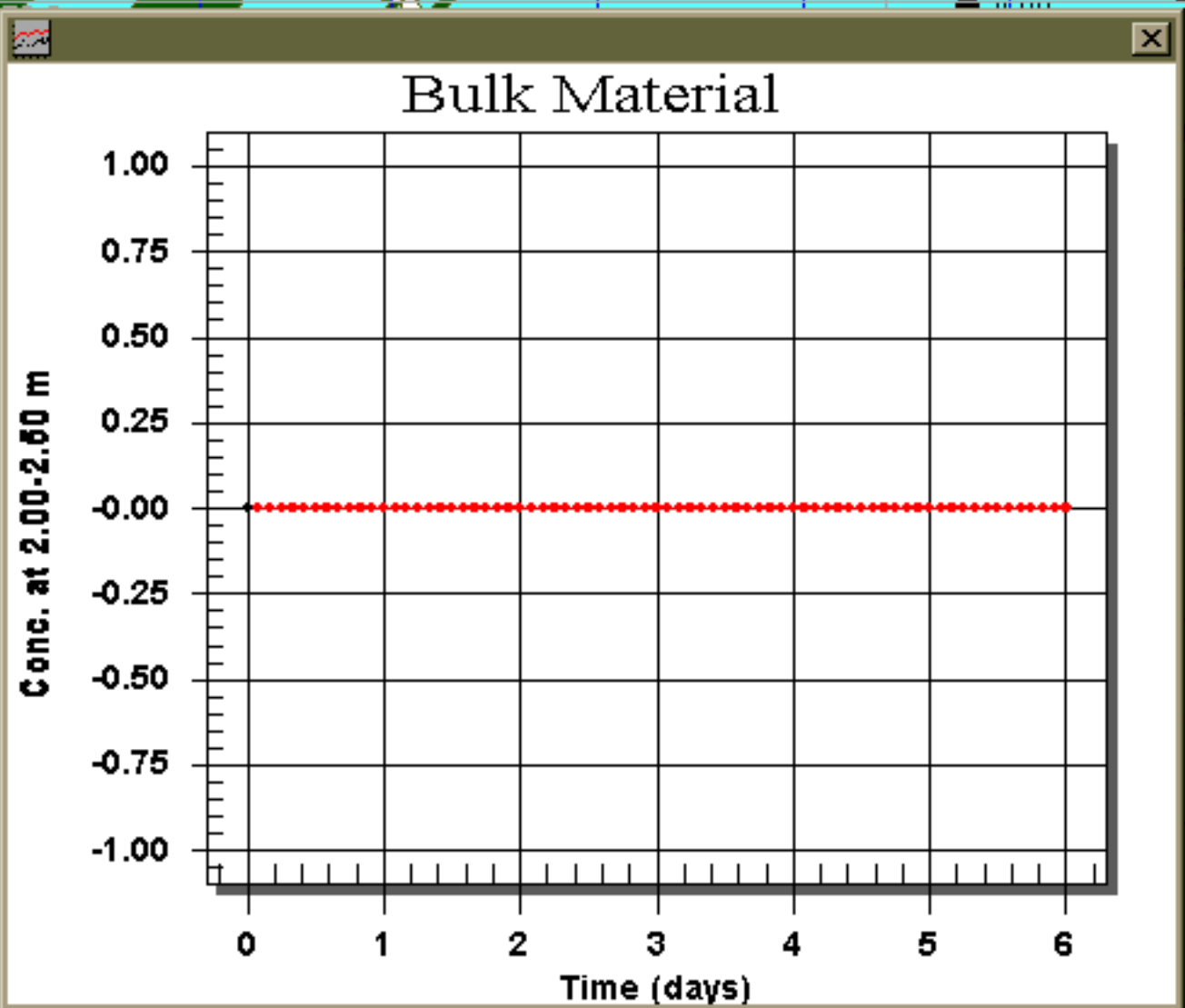

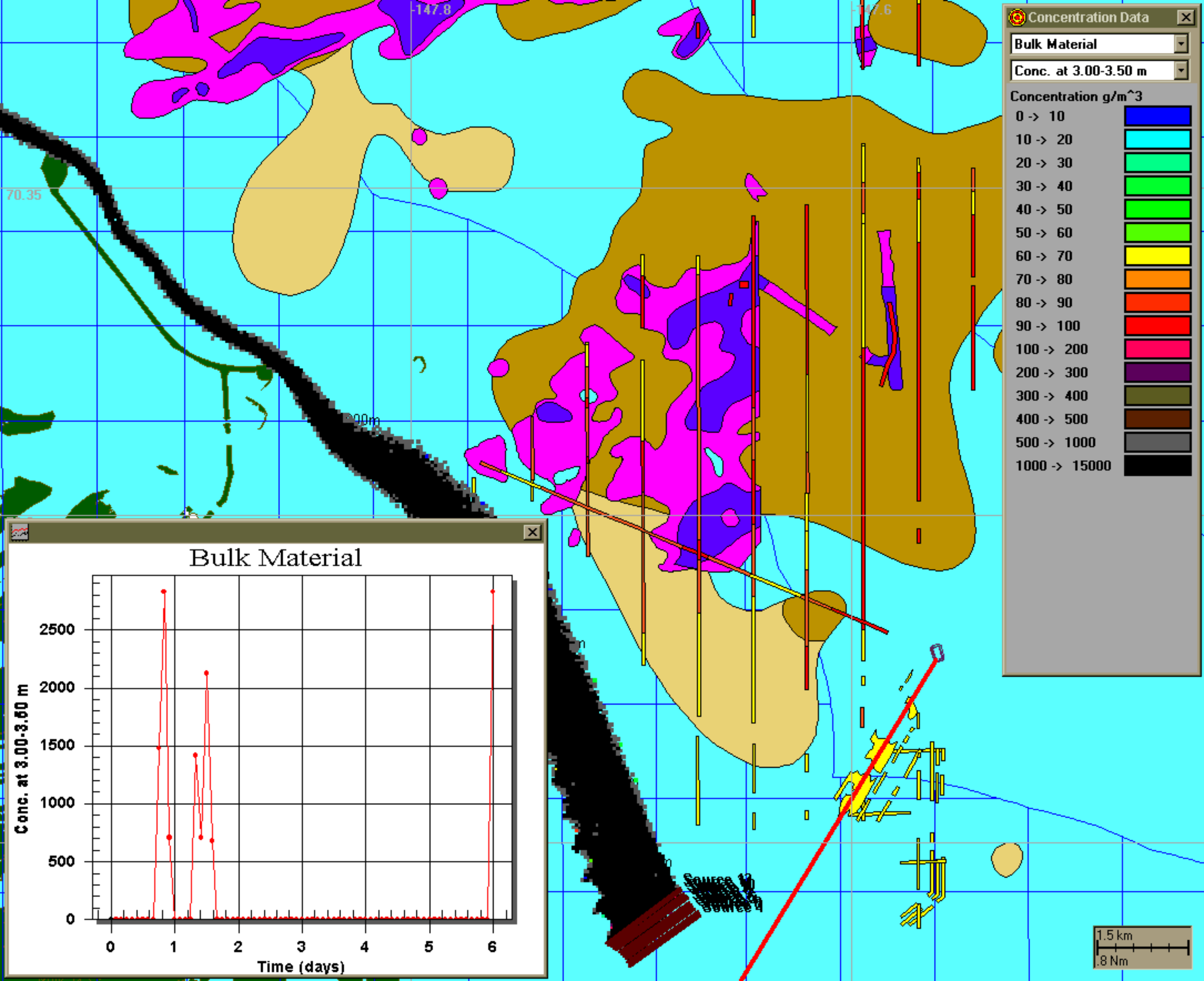

Concentration Data

Bulk Material

Conc. at 3.00-3.50 m

Concentration g/m³

0 -> 10	Blue
10 -> 20	Cyan
20 -> 30	Light Green
30 -> 40	Green
40 -> 50	Bright Green
50 -> 60	Yellow-Green
60 -> 70	Yellow
70 -> 80	Orange
80 -> 90	Red-Orange
90 -> 100	Red
100 -> 200	Magenta
200 -> 300	Purple
300 -> 400	Olive
400 -> 500	Brown
500 -> 1000	Grey
1000 -> 15000	Black

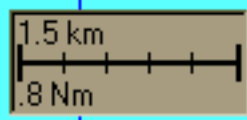
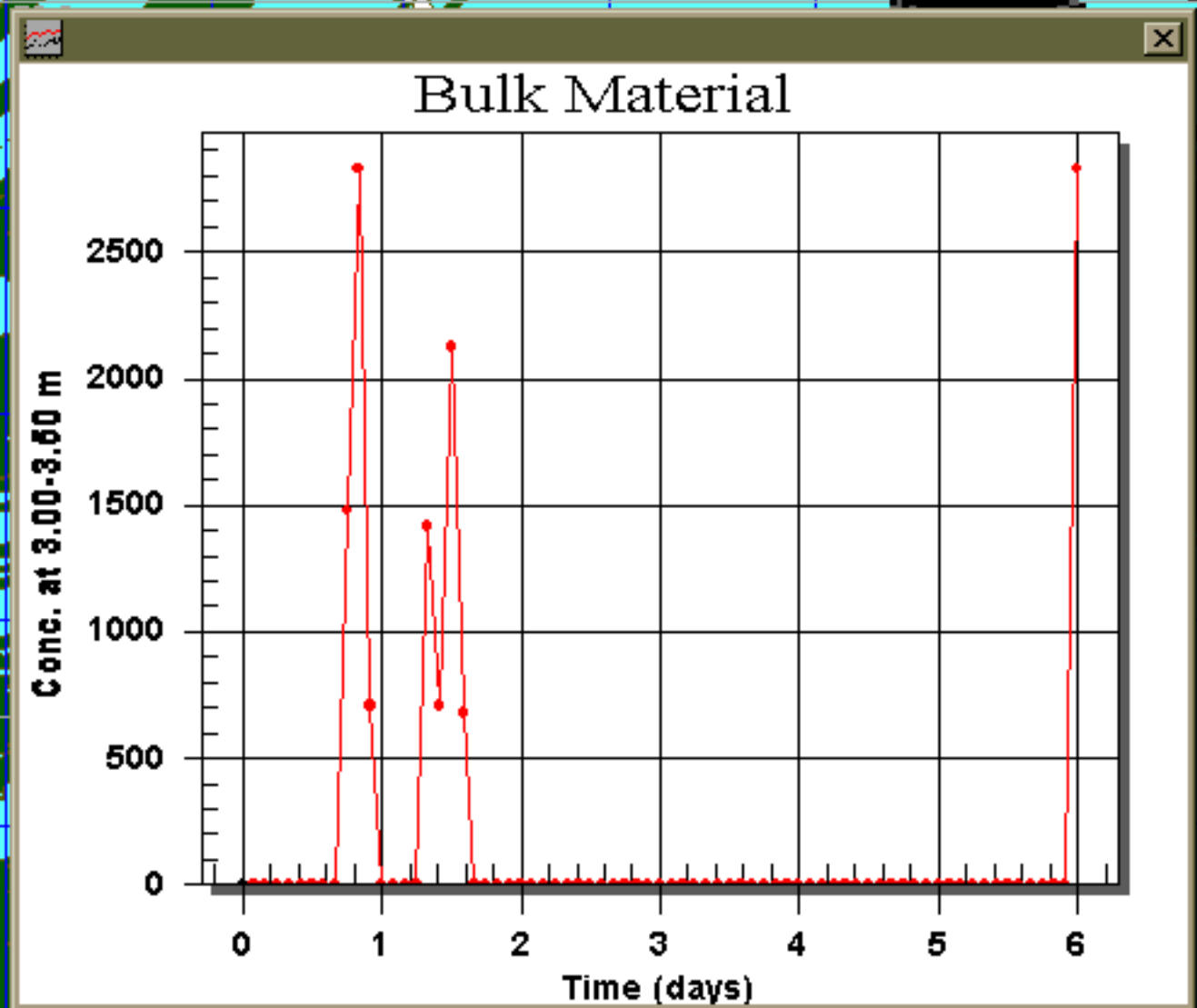

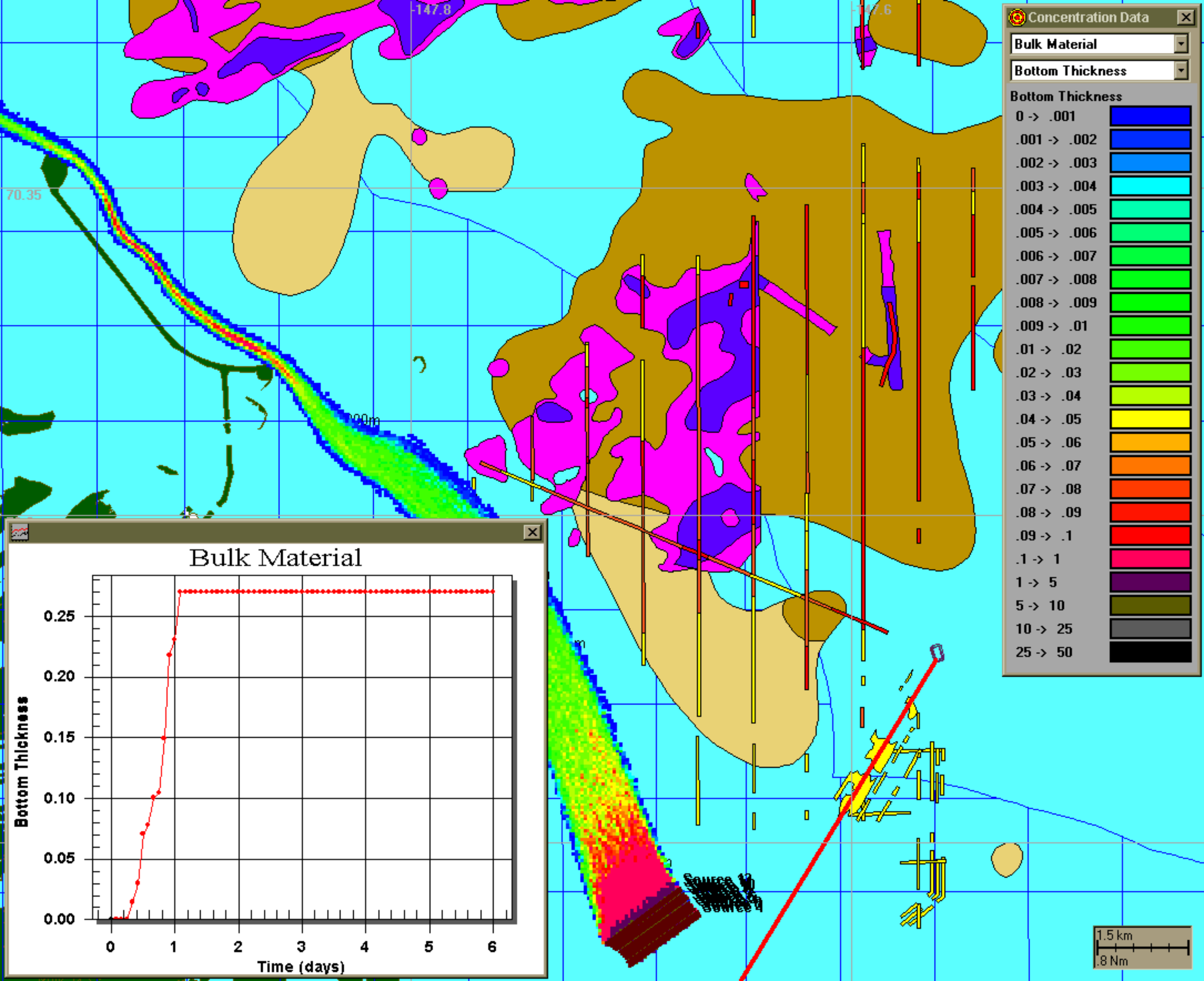

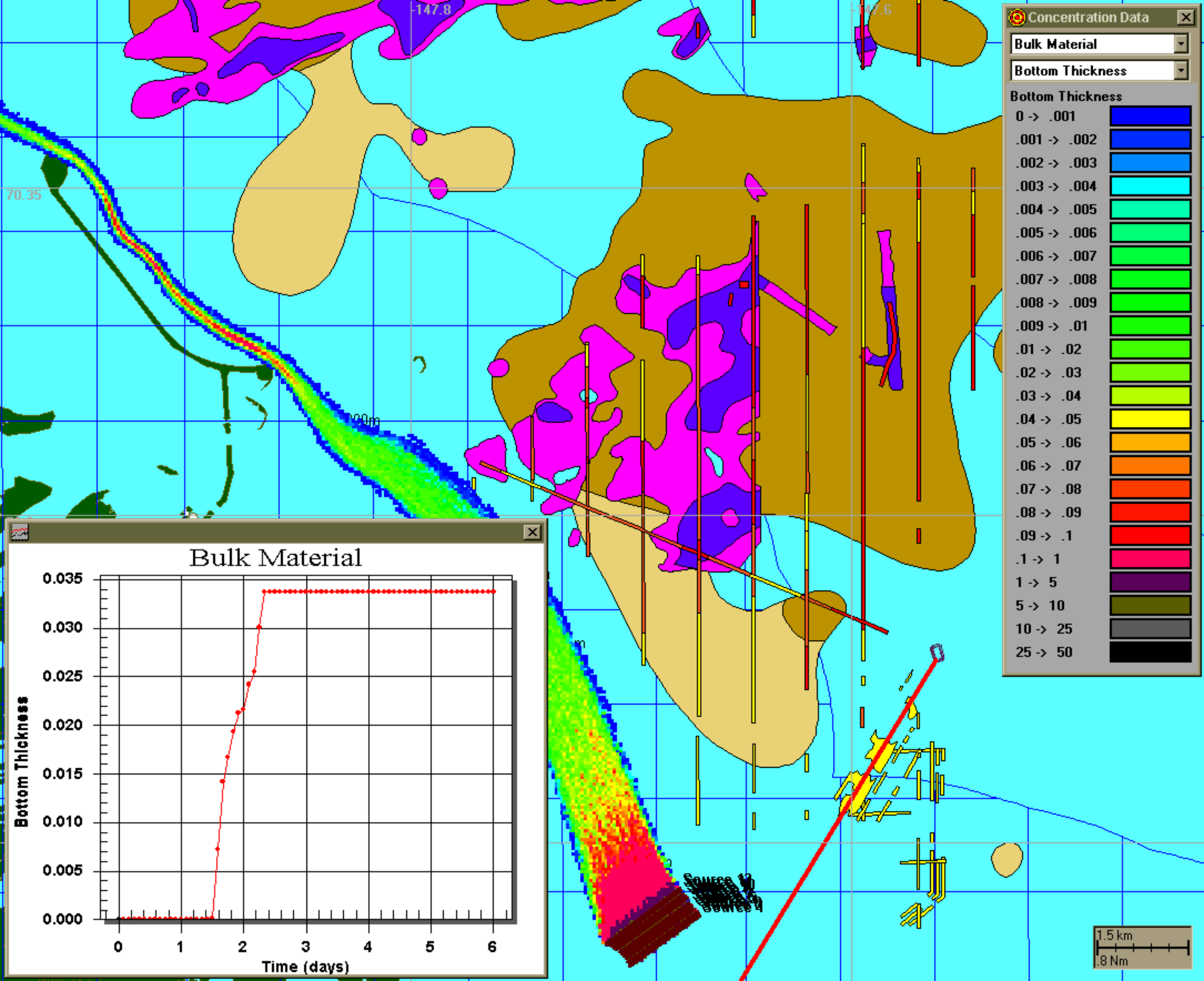

Concentration Data

Bulk Material

Bottom Thickness

Bottom Thickness

0 -> .001	[Dark Blue]
.001 -> .002	[Blue]
.002 -> .003	[Light Blue]
.003 -> .004	[Cyan]
.004 -> .005	[Green-Cyan]
.005 -> .006	[Green]
.006 -> .007	[Light Green]
.007 -> .008	[Green]
.008 -> .009	[Light Green]
.009 -> .01	[Green]
.01 -> .02	[Light Green]
.02 -> .03	[Yellow-Green]
.03 -> .04	[Yellow]
.04 -> .05	[Light Yellow]
.05 -> .06	[Orange]
.06 -> .07	[Red-Orange]
.07 -> .08	[Red]
.08 -> .09	[Dark Red]
.09 -> .1	[Red]
.1 -> 1	[Magenta]
1 -> 5	[Purple]
5 -> 10	[Olive]
10 -> 25	[Grey]
25 -> 50	[Black]

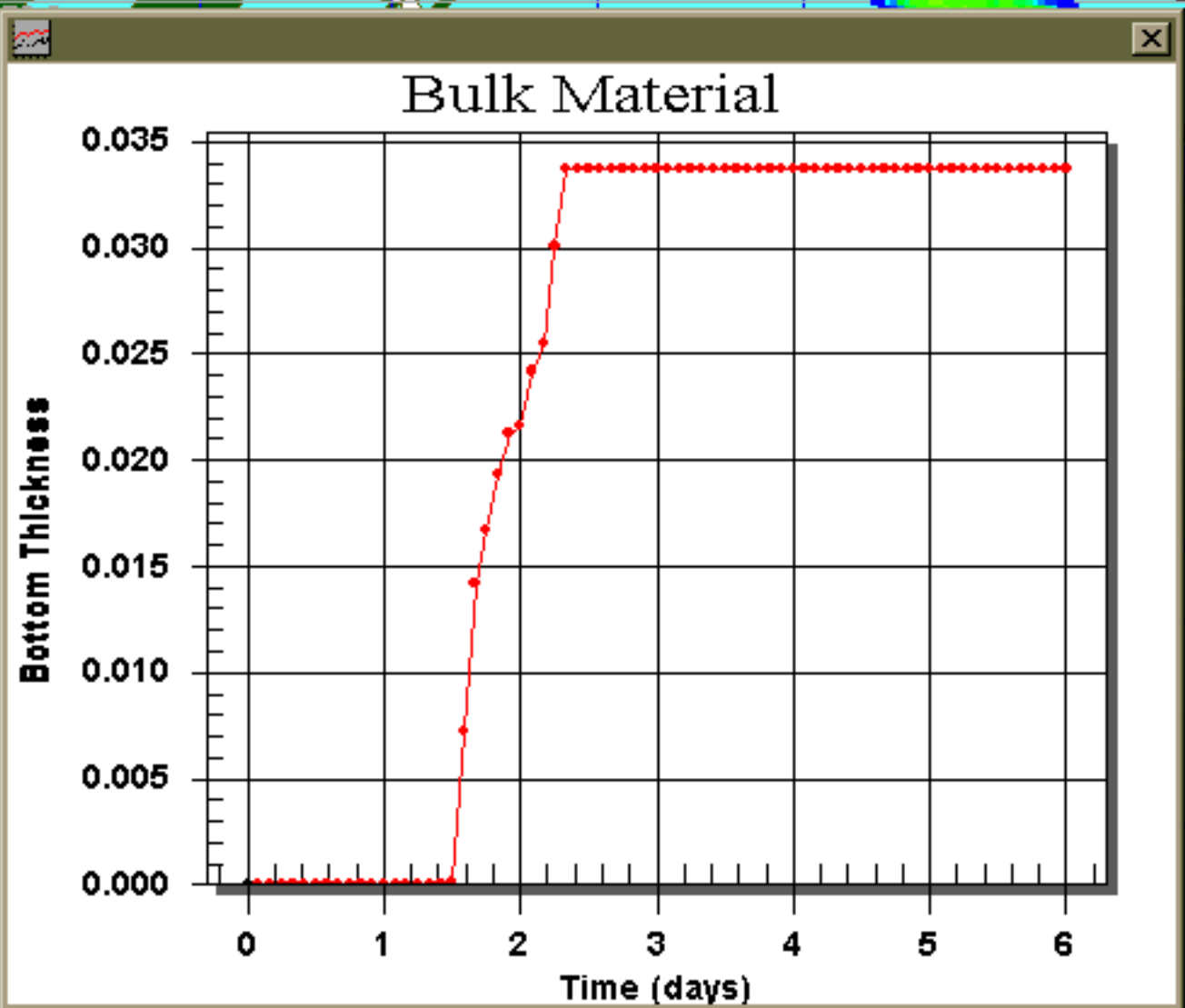

1.5 km
0.8 Nm

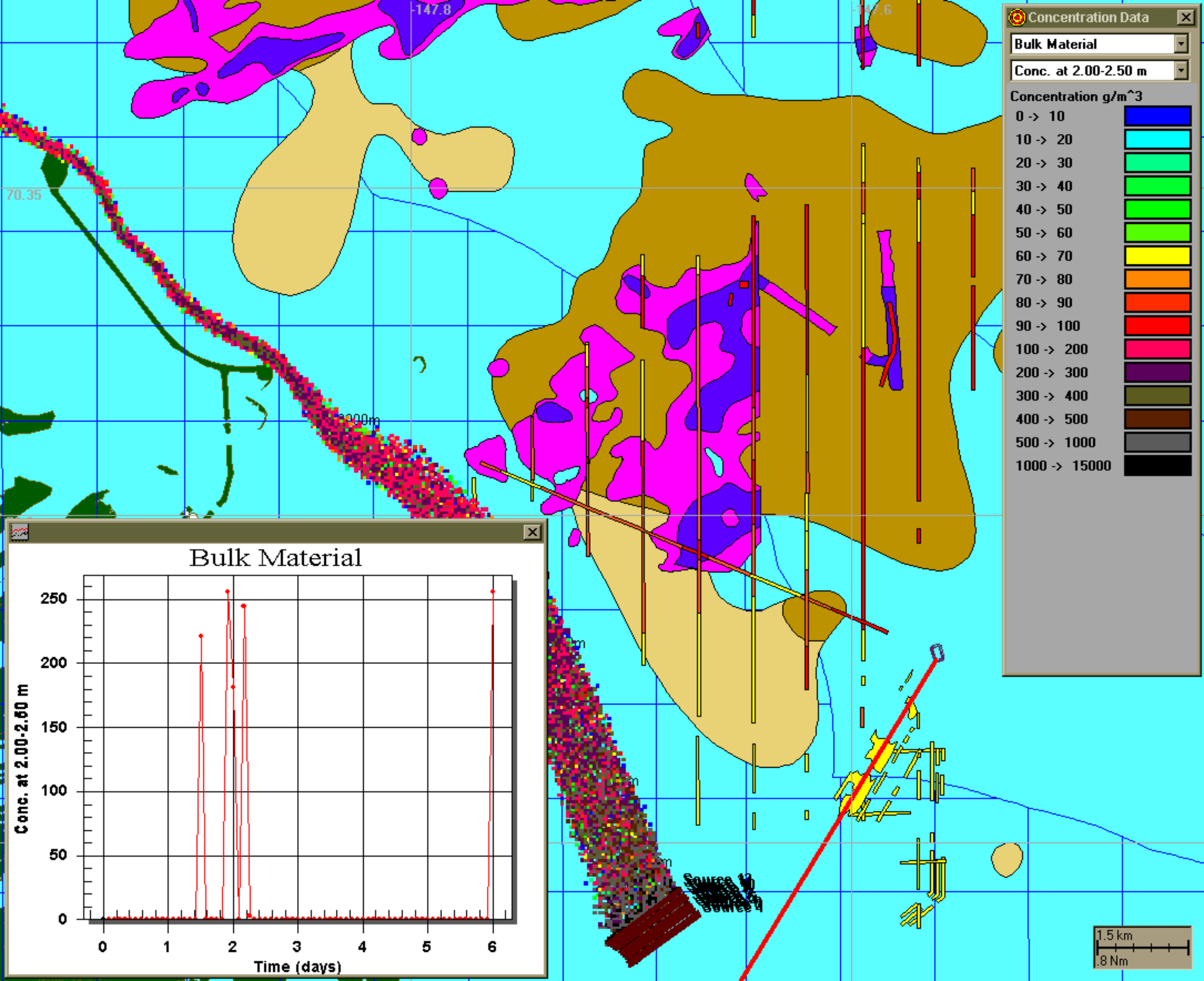

Concentration Data

Bulk Material

Conc. at 2.00-2.50 m

Concentration g/m^3

0 -> 10	Blue
10 -> 20	Cyan
20 -> 30	Light Green
30 -> 40	Green
40 -> 50	Bright Green
50 -> 60	Yellow-Green
60 -> 70	Yellow
70 -> 80	Orange
80 -> 90	Red-Orange
90 -> 100	Red
100 -> 200	Magenta
200 -> 300	Purple
300 -> 400	Olive
400 -> 500	Brown
500 -> 1000	Grey
1000 -> 15000	Black

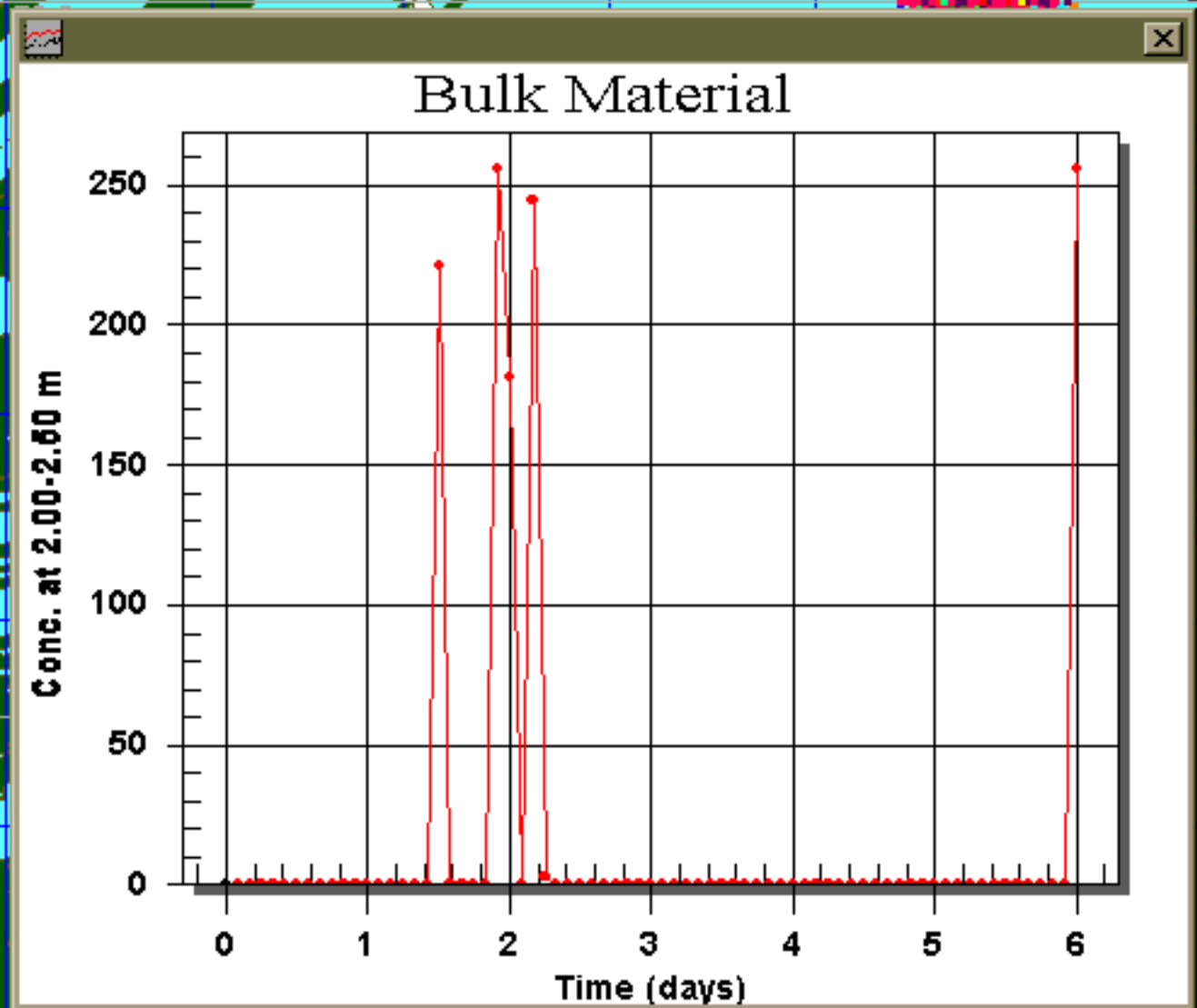

1.5 km
0.8 Nm

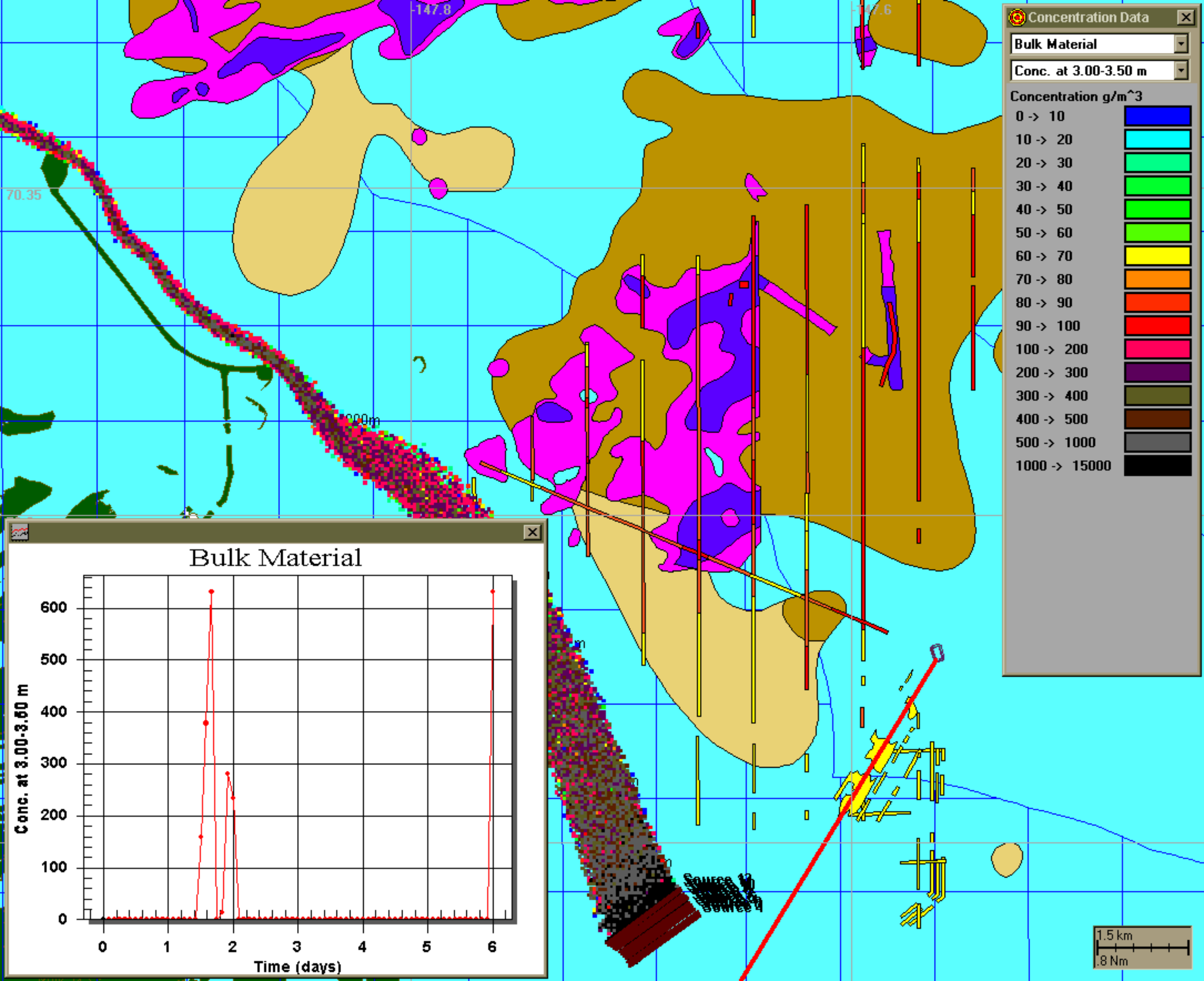

Concentration Data

Bulk Material

Conc. at 3.00-3.50 m

Concentration g/m^3

0 -> 10	Blue
10 -> 20	Cyan
20 -> 30	Light Green
30 -> 40	Green
40 -> 50	Bright Green
50 -> 60	Yellow-Green
60 -> 70	Yellow
70 -> 80	Orange
80 -> 90	Red-Orange
90 -> 100	Red
100 -> 200	Magenta
200 -> 300	Purple
300 -> 400	Olive
400 -> 500	Brown
500 -> 1000	Grey
1000 -> 15000	Black

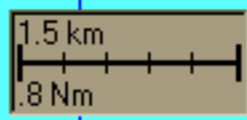
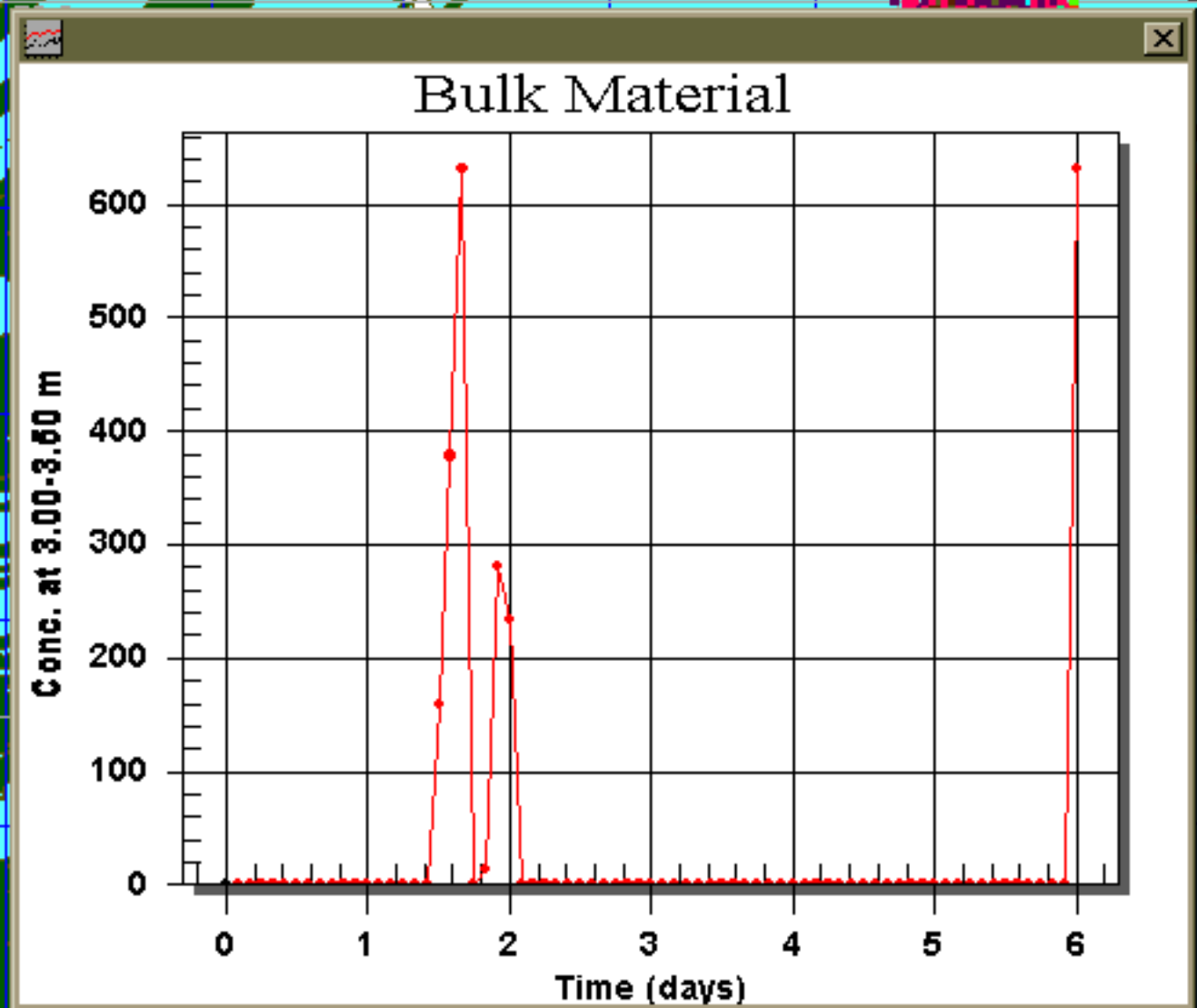

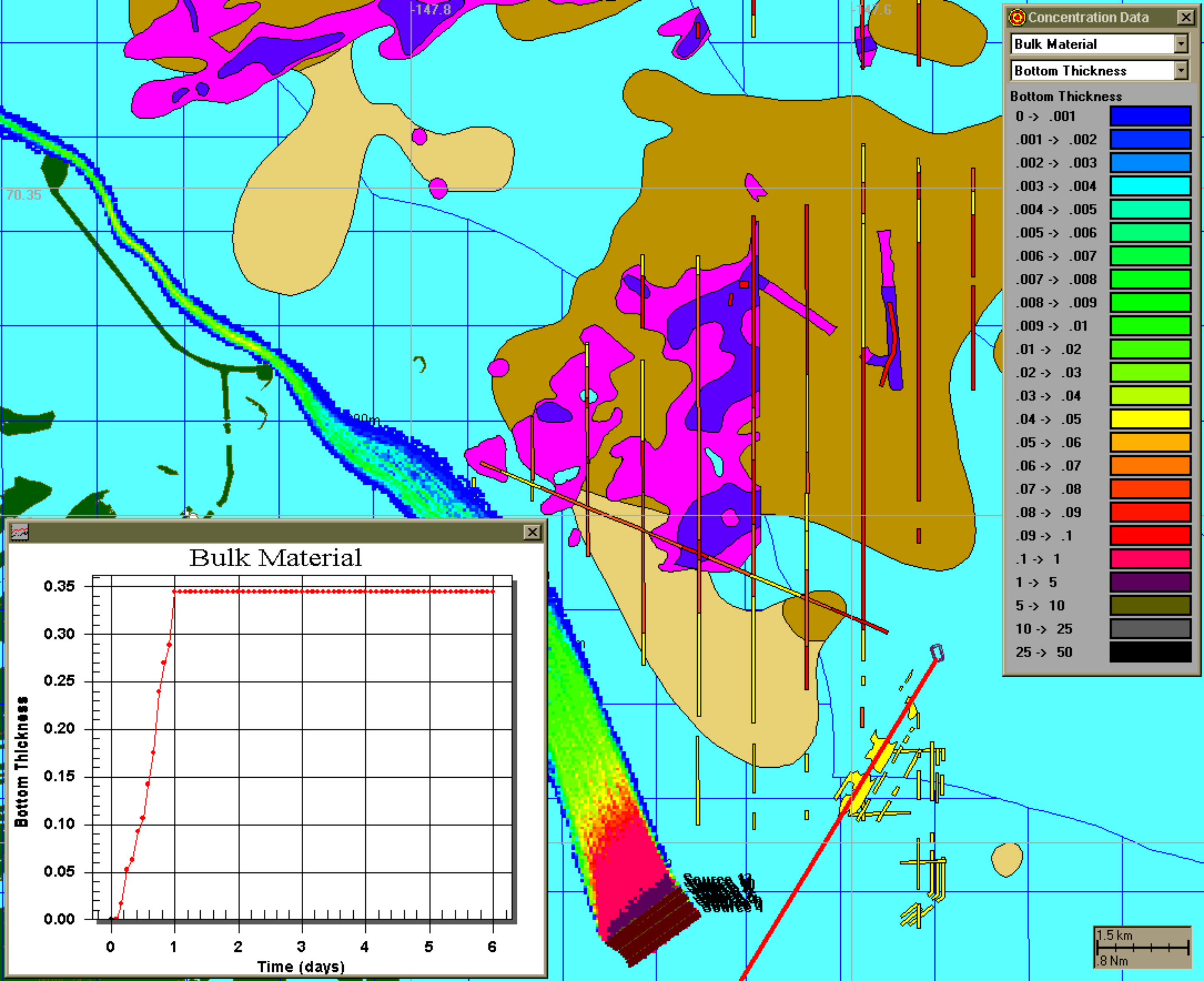

Concentration Data

Bulk Material

Bottom Thickness

Bottom Thickness

0 -> .001	[Dark Blue]
.001 -> .002	[Blue]
.002 -> .003	[Light Blue]
.003 -> .004	[Cyan]
.004 -> .005	[Green-Cyan]
.005 -> .006	[Green]
.006 -> .007	[Light Green]
.007 -> .008	[Green]
.008 -> .009	[Light Green]
.009 -> .01	[Green]
.01 -> .02	[Light Green]
.02 -> .03	[Yellow-Green]
.03 -> .04	[Yellow]
.04 -> .05	[Light Yellow]
.05 -> .06	[Yellow-Orange]
.06 -> .07	[Orange]
.07 -> .08	[Red-Orange]
.08 -> .09	[Red]
.09 -> .1	[Dark Red]
.1 -> 1	[Magenta]
1 -> 5	[Purple]
5 -> 10	[Dark Purple]
10 -> 25	[Grey]
25 -> 50	[Black]

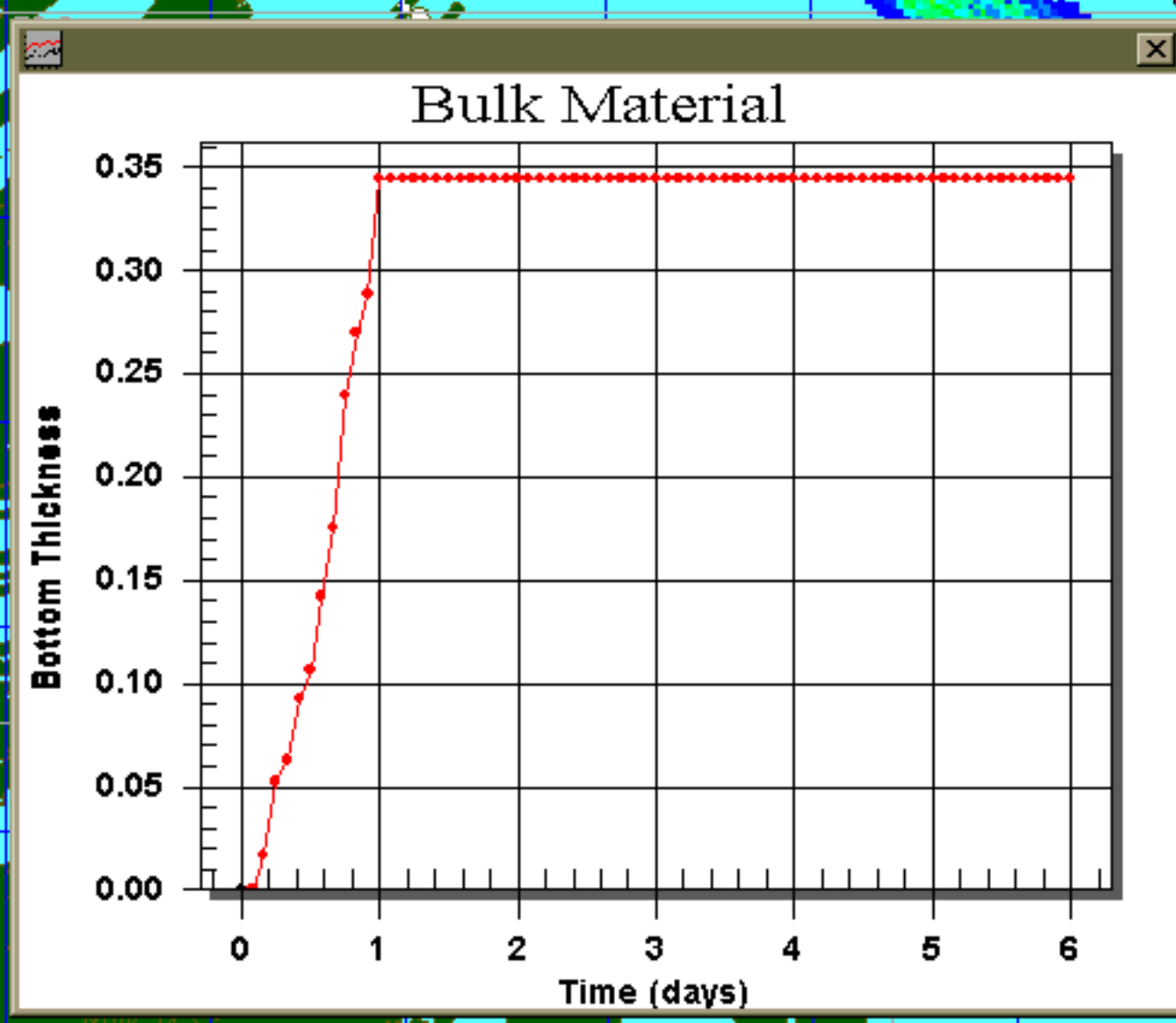

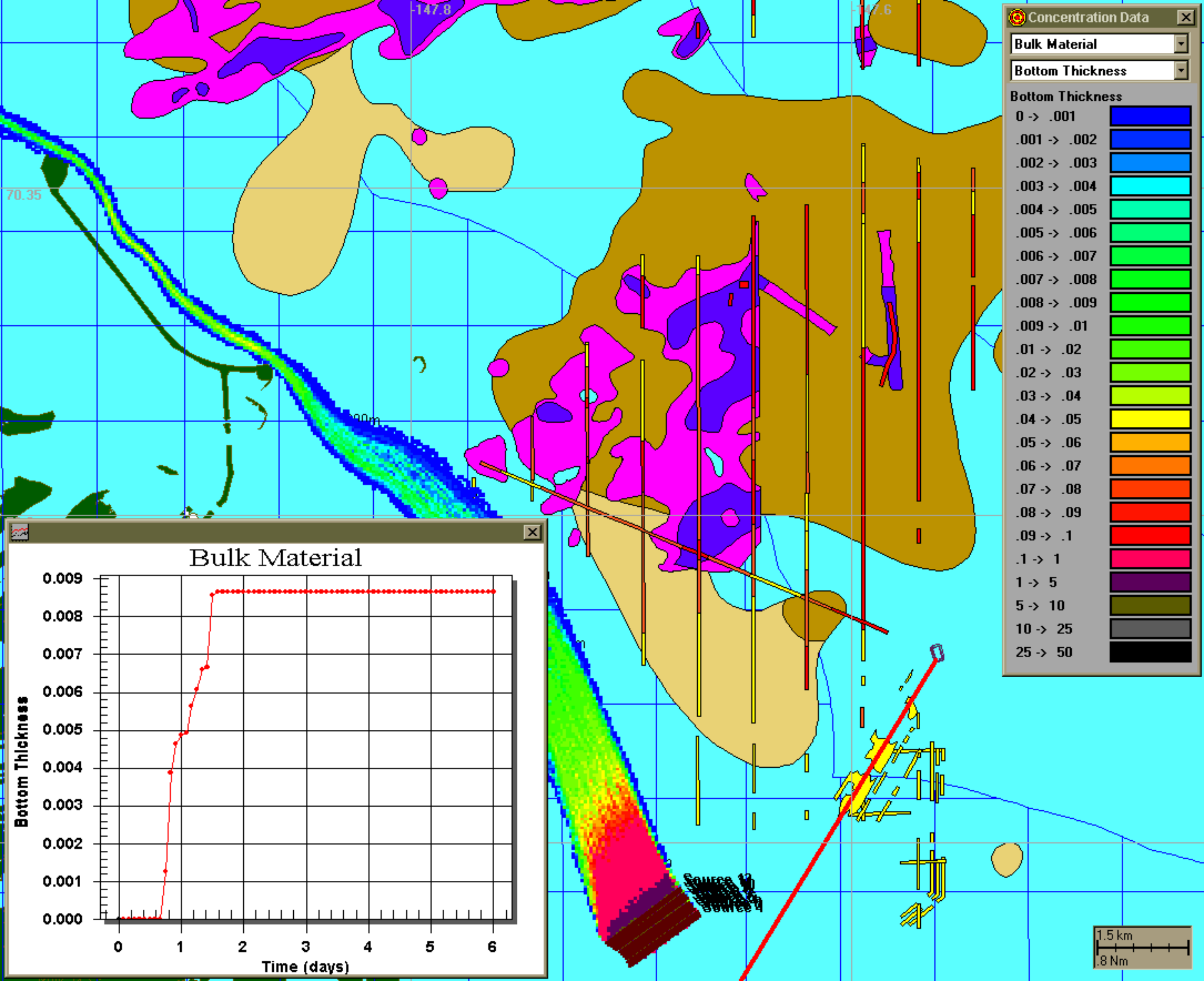

Concentration Data

Bulk Material

Bottom Thickness

Bottom Thickness

0 -> .001	[Dark Blue]
.001 -> .002	[Blue]
.002 -> .003	[Light Blue]
.003 -> .004	[Cyan]
.004 -> .005	[Green-Cyan]
.005 -> .006	[Green]
.006 -> .007	[Light Green]
.007 -> .008	[Green]
.008 -> .009	[Light Green]
.009 -> .01	[Green]
.01 -> .02	[Light Green]
.02 -> .03	[Yellow-Green]
.03 -> .04	[Yellow]
.04 -> .05	[Light Yellow]
.05 -> .06	[Orange]
.06 -> .07	[Red-Orange]
.07 -> .08	[Red]
.08 -> .09	[Dark Red]
.09 -> .1	[Red]
.1 -> 1	[Magenta]
1 -> 5	[Purple]
5 -> 10	[Olive Green]
10 -> 25	[Grey]
25 -> 50	[Black]

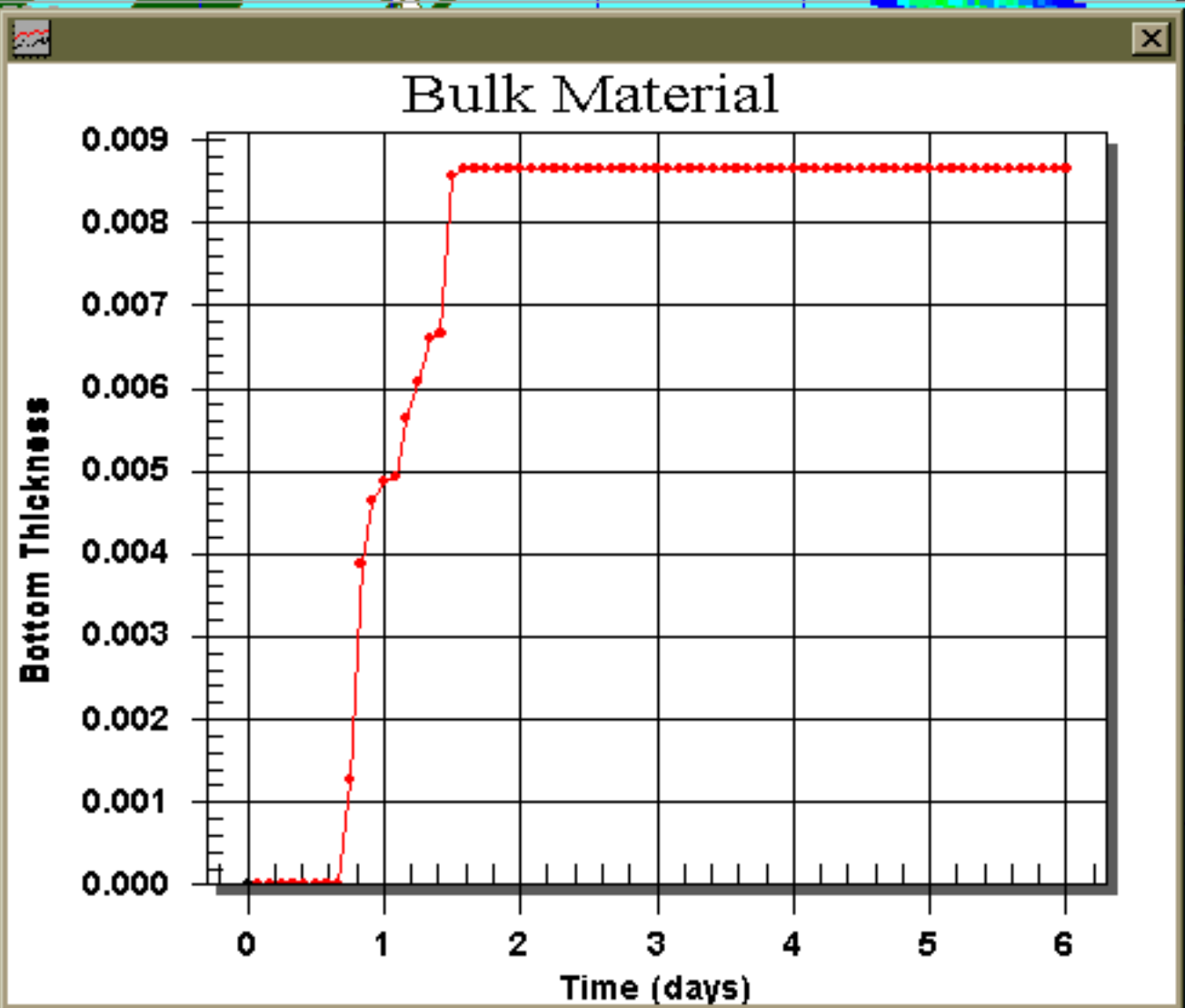

1.5 km
0.8 Nm

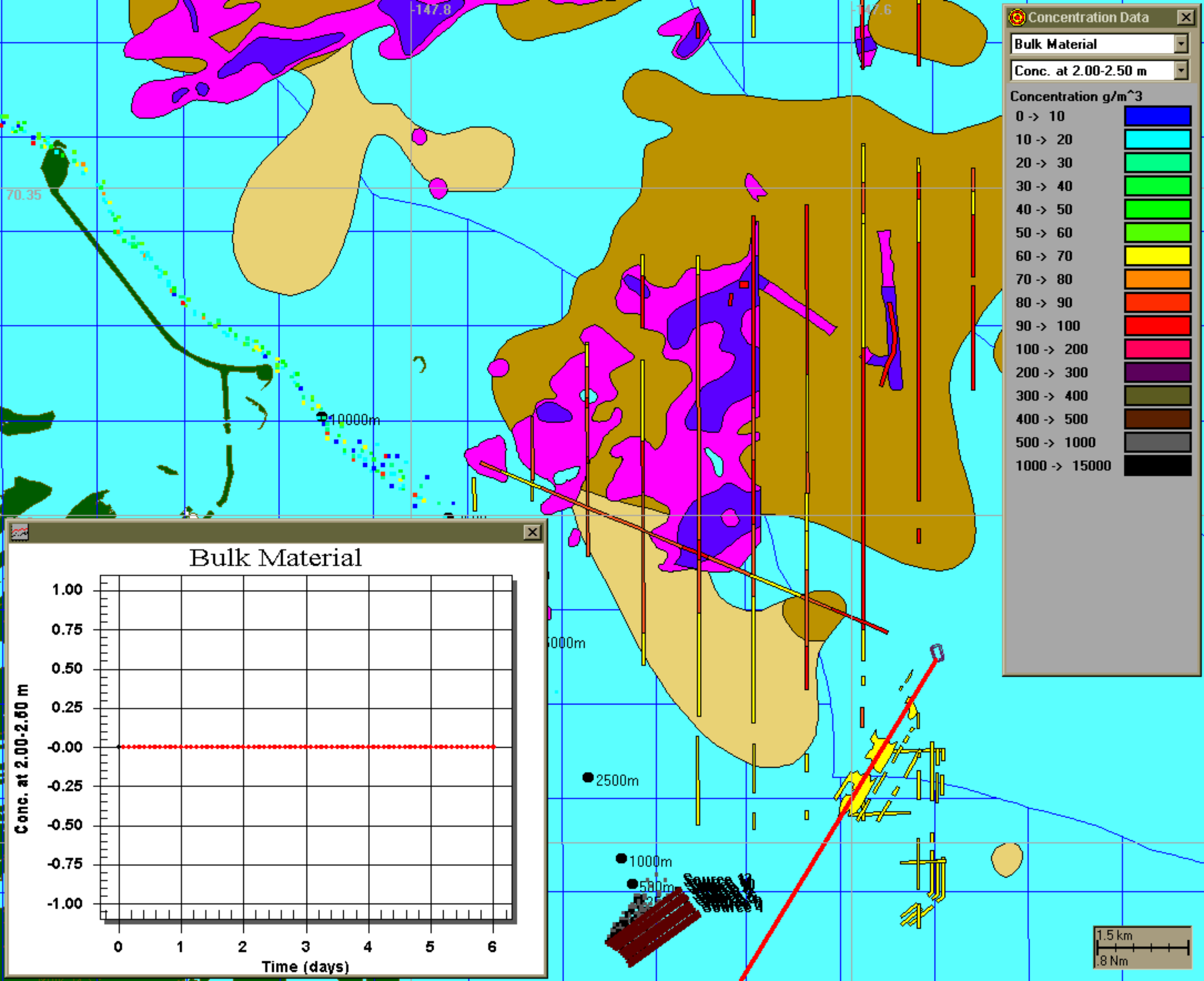

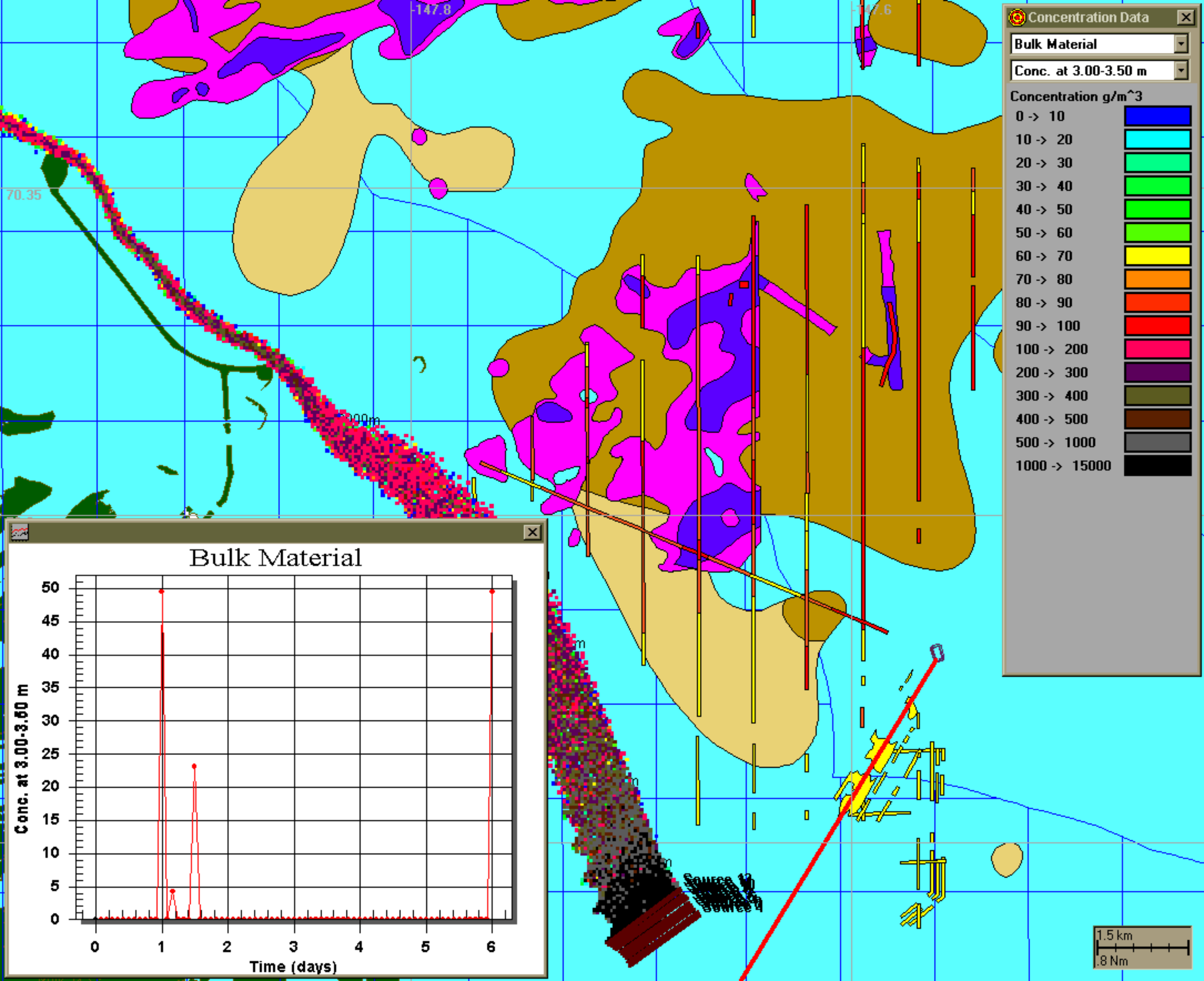

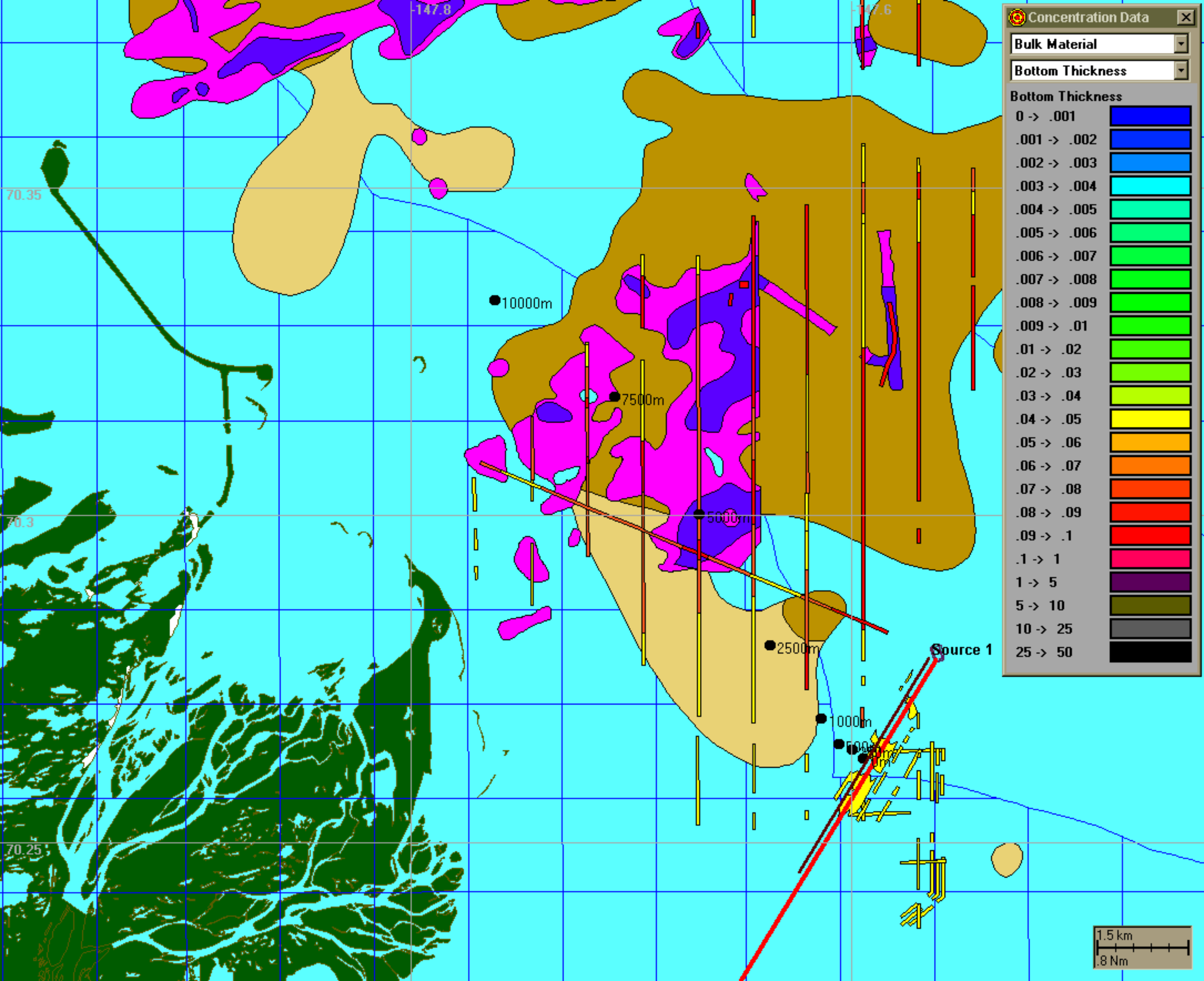

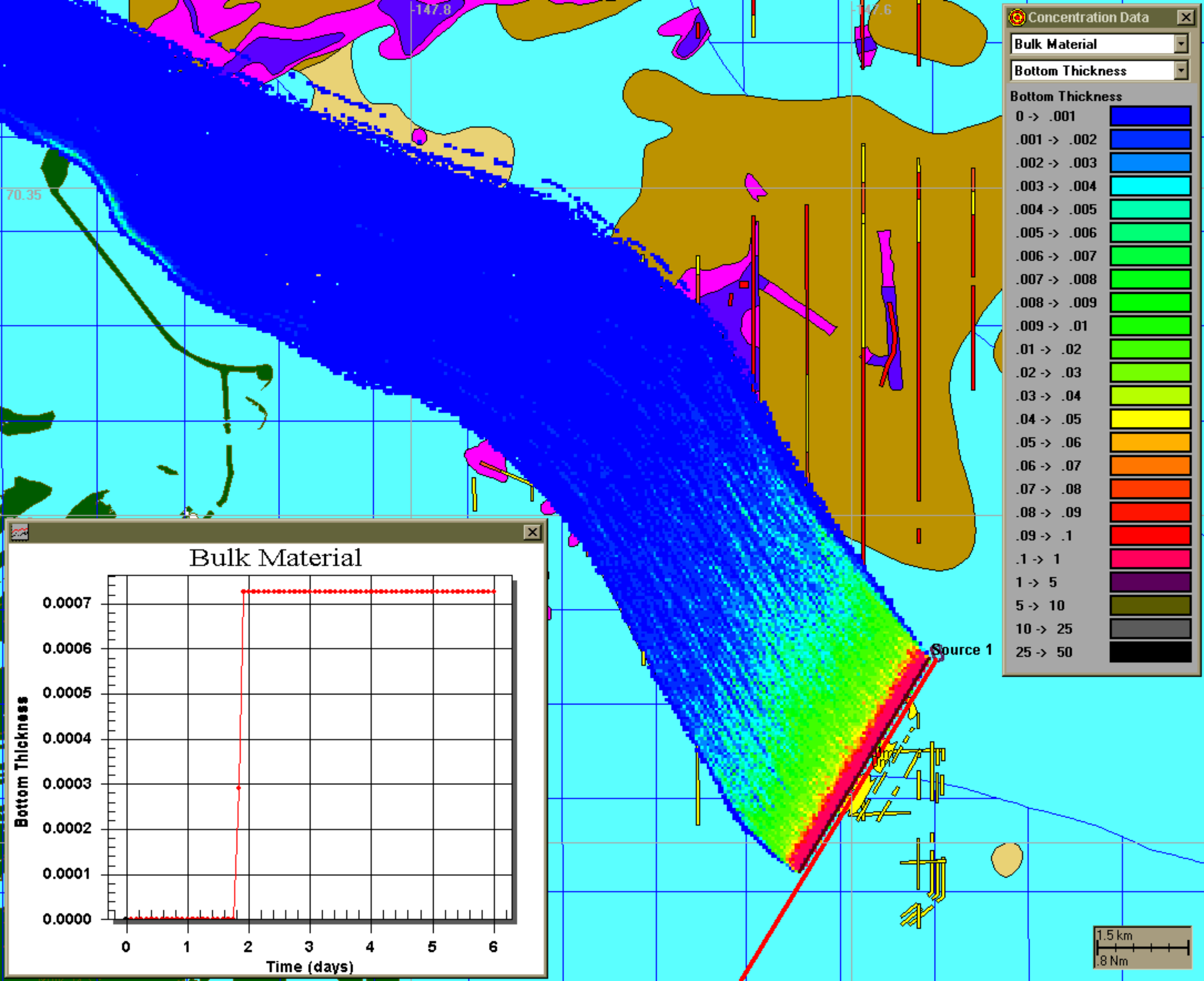

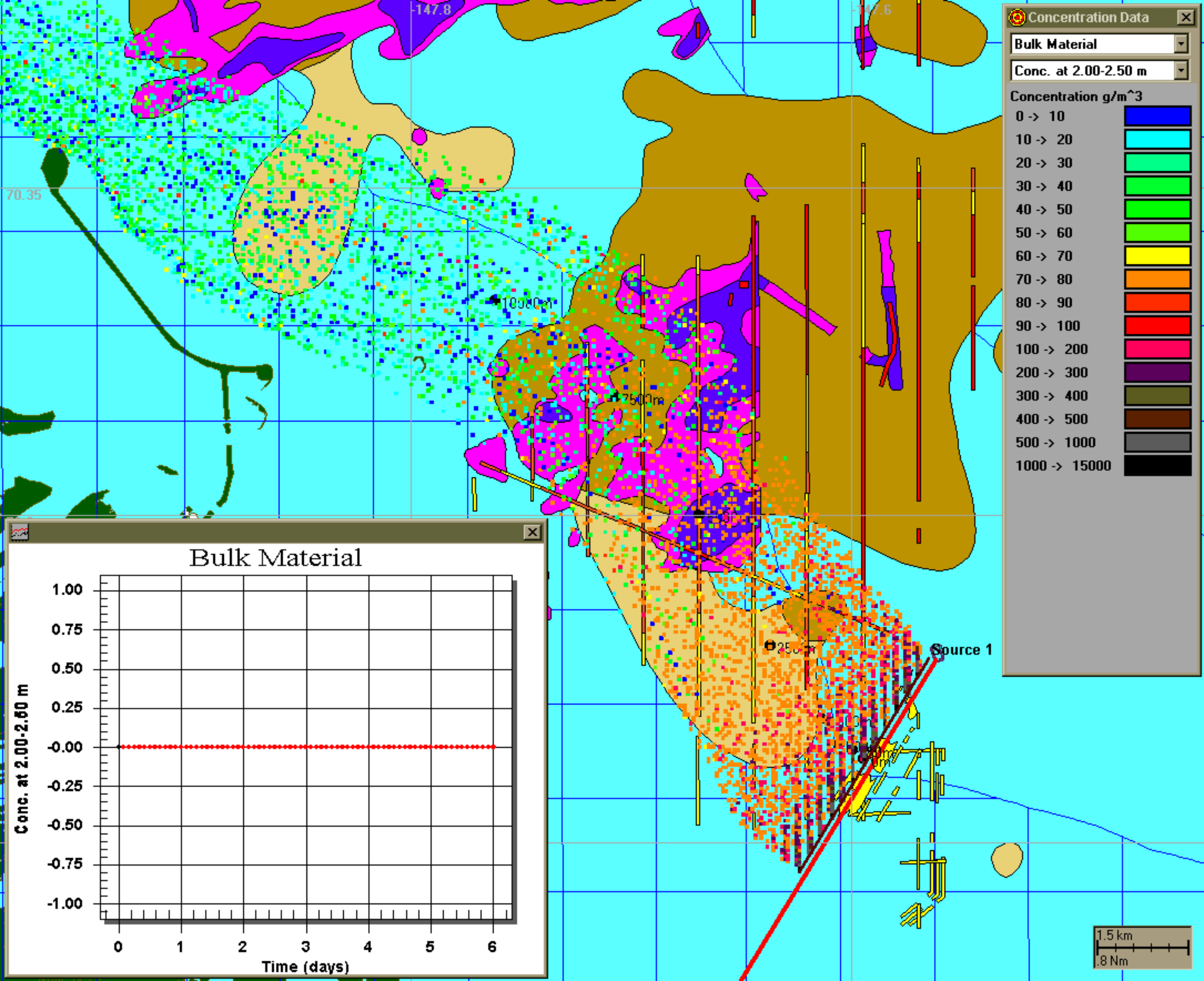

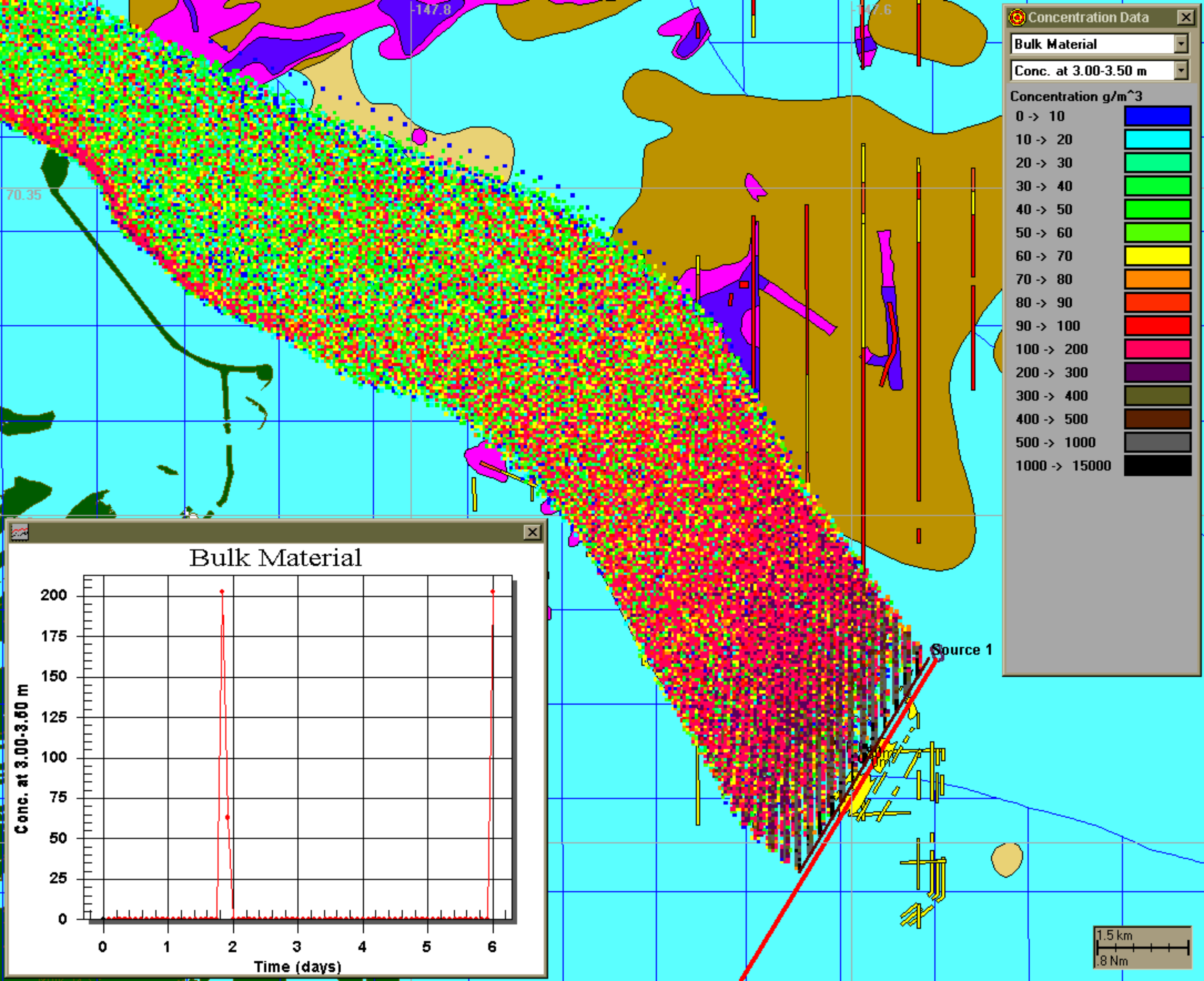

Concentration Data

Bulk Material

Conc. at 3.00-3.50 m

Concentration g/m^3

0 -> 10	Blue
10 -> 20	Cyan
20 -> 30	Green
30 -> 40	Light Green
40 -> 50	Yellow-Green
50 -> 60	Yellow
60 -> 70	Orange
70 -> 80	Red-Orange
80 -> 90	Red
90 -> 100	Dark Red
100 -> 200	Magenta
200 -> 300	Purple
300 -> 400	Dark Purple
400 -> 500	Black
500 -> 1000	Dark Grey
1000 -> 15000	Black

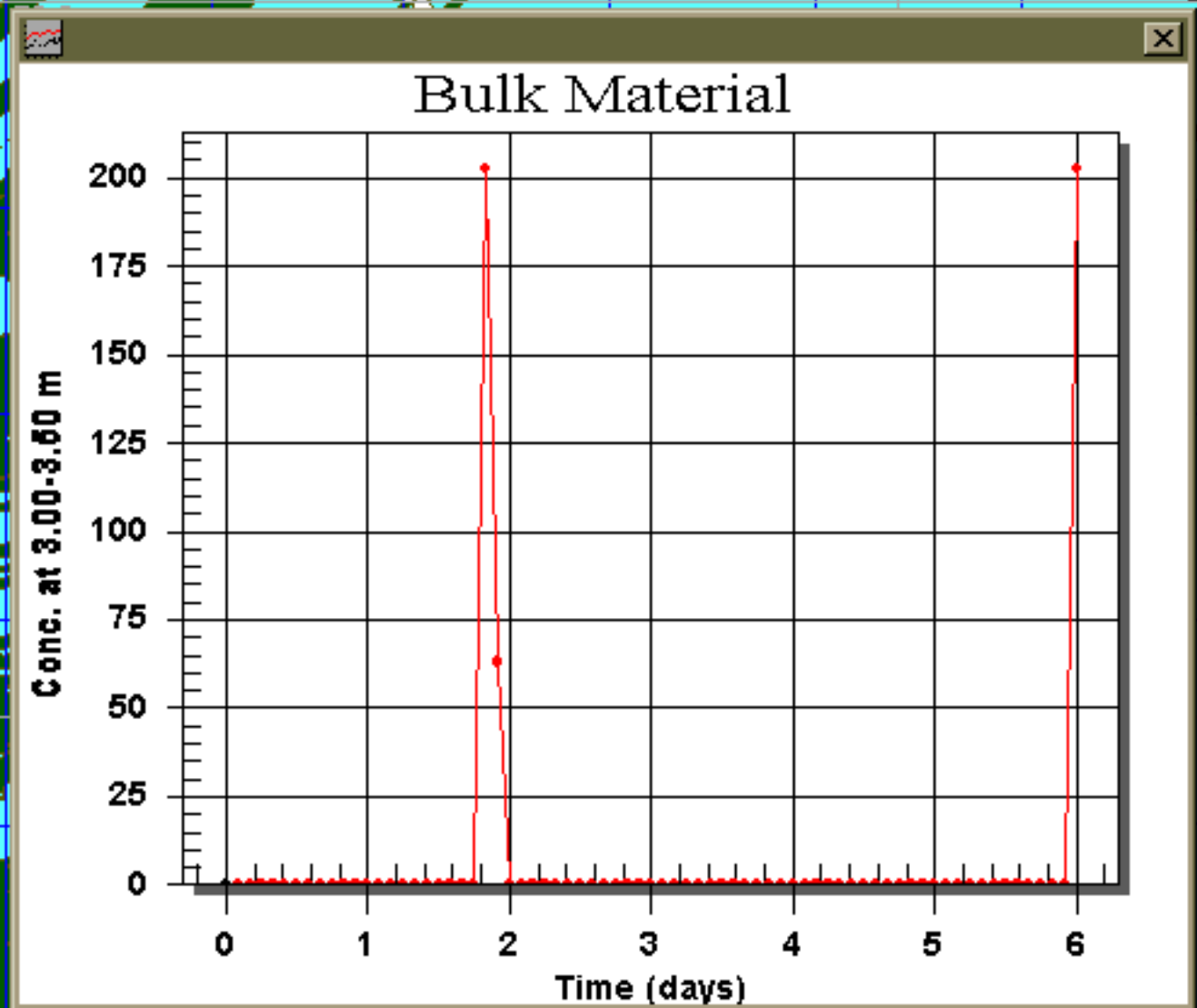

1.5 km
0.8 Nm

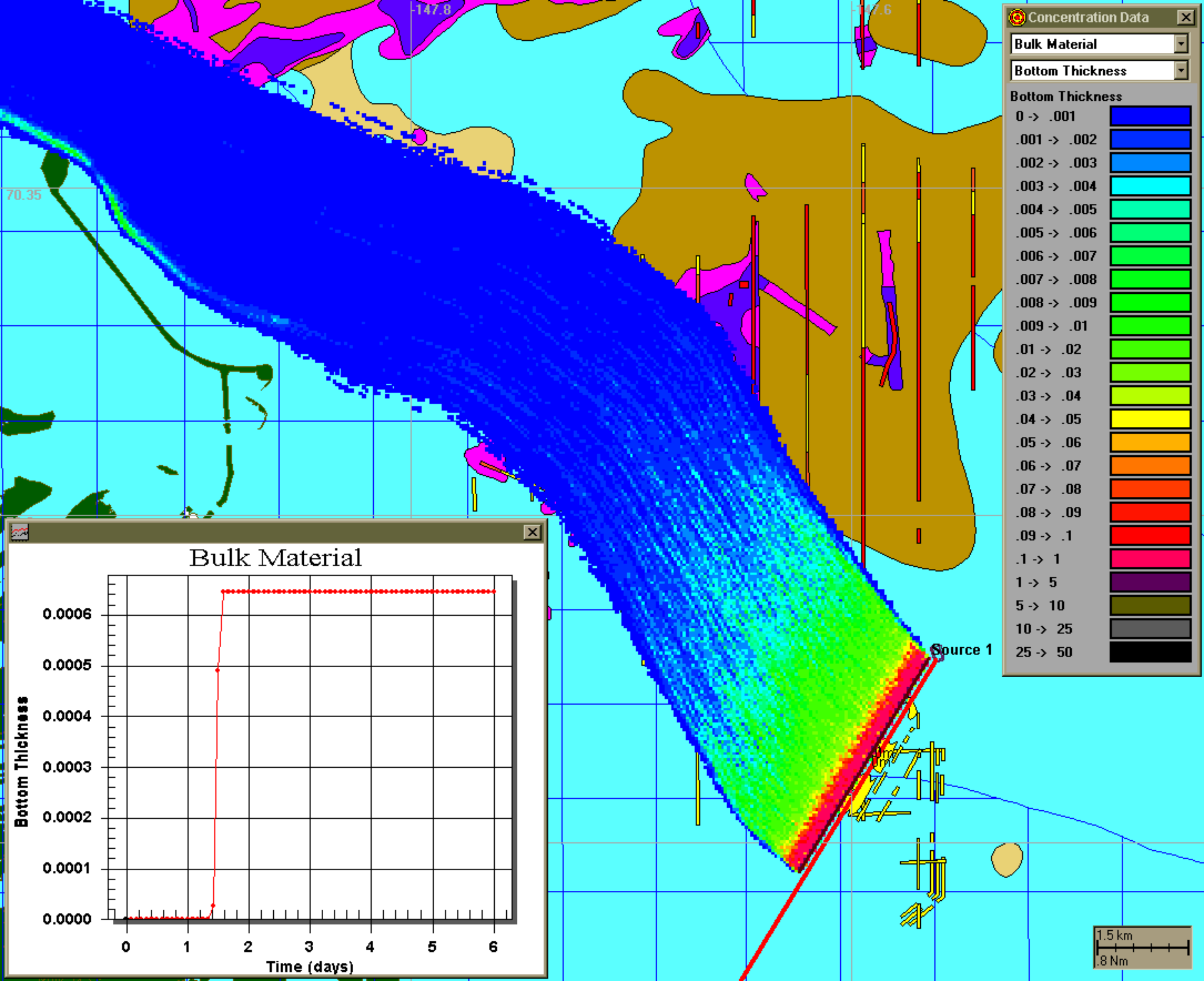

Concentration Data

Bulk Material

Bottom Thickness

Bottom Thickness

0 -> .001	[Blue]
.001 -> .002	[Light Blue]
.002 -> .003	[Cyan]
.003 -> .004	[Green-Cyan]
.004 -> .005	[Green]
.005 -> .006	[Light Green]
.006 -> .007	[Yellow-Green]
.007 -> .008	[Yellow]
.008 -> .009	[Orange-Yellow]
.009 -> .01	[Orange]
.01 -> .02	[Red-Orange]
.02 -> .03	[Red]
.03 -> .04	[Dark Red]
.04 -> .05	[Magenta]
.05 -> .06	[Purple]
.06 -> .07	[Dark Purple]
.07 -> .08	[Black]
.08 -> .09	[Dark Grey]
.09 -> .1	[Grey]
.1 -> 1	[Light Grey]
1 -> 5	[White]
5 -> 10	[Light Blue]
10 -> 25	[Medium Blue]
25 -> 50	[Dark Blue]

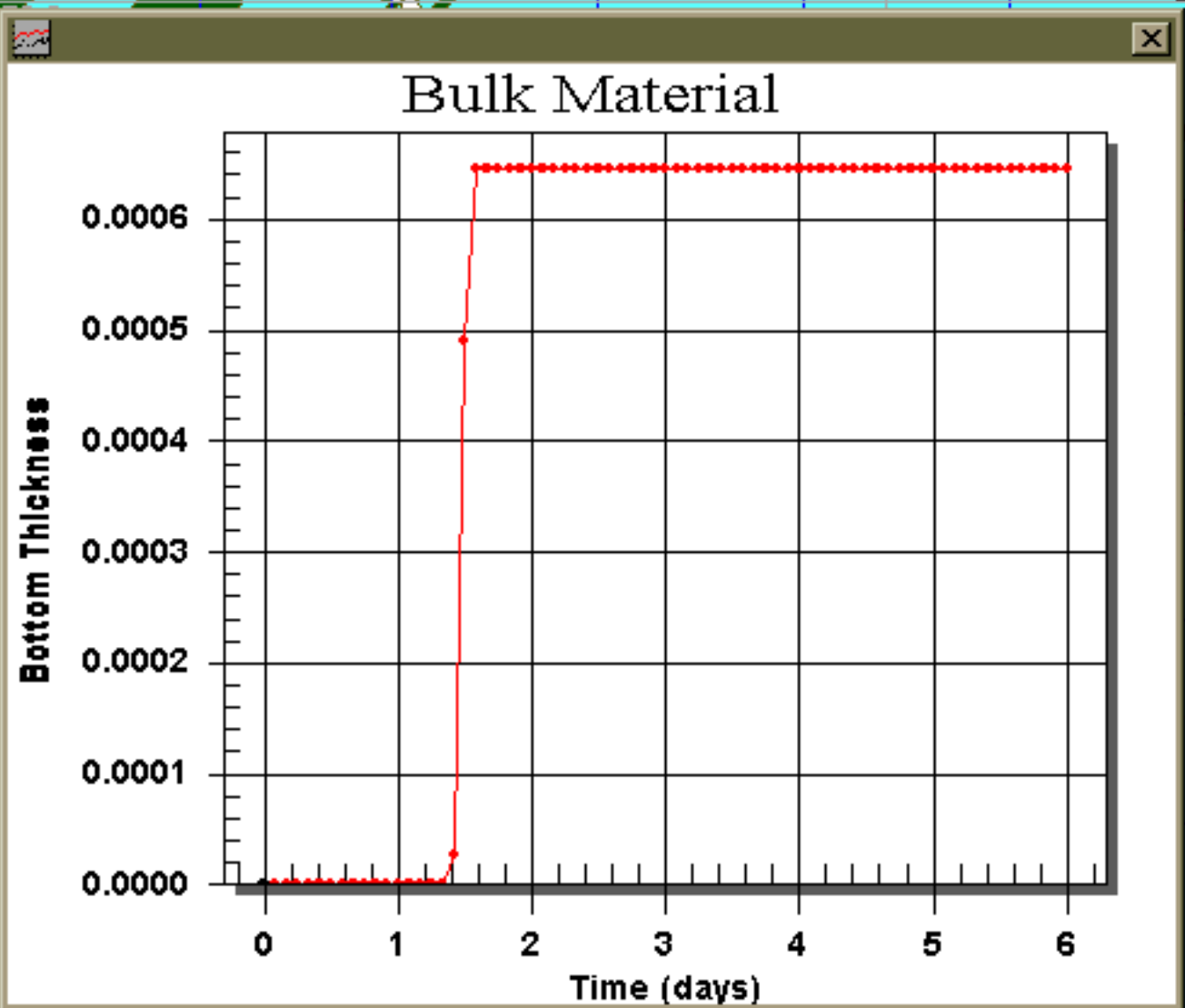

1.5 km
0.8 Nm

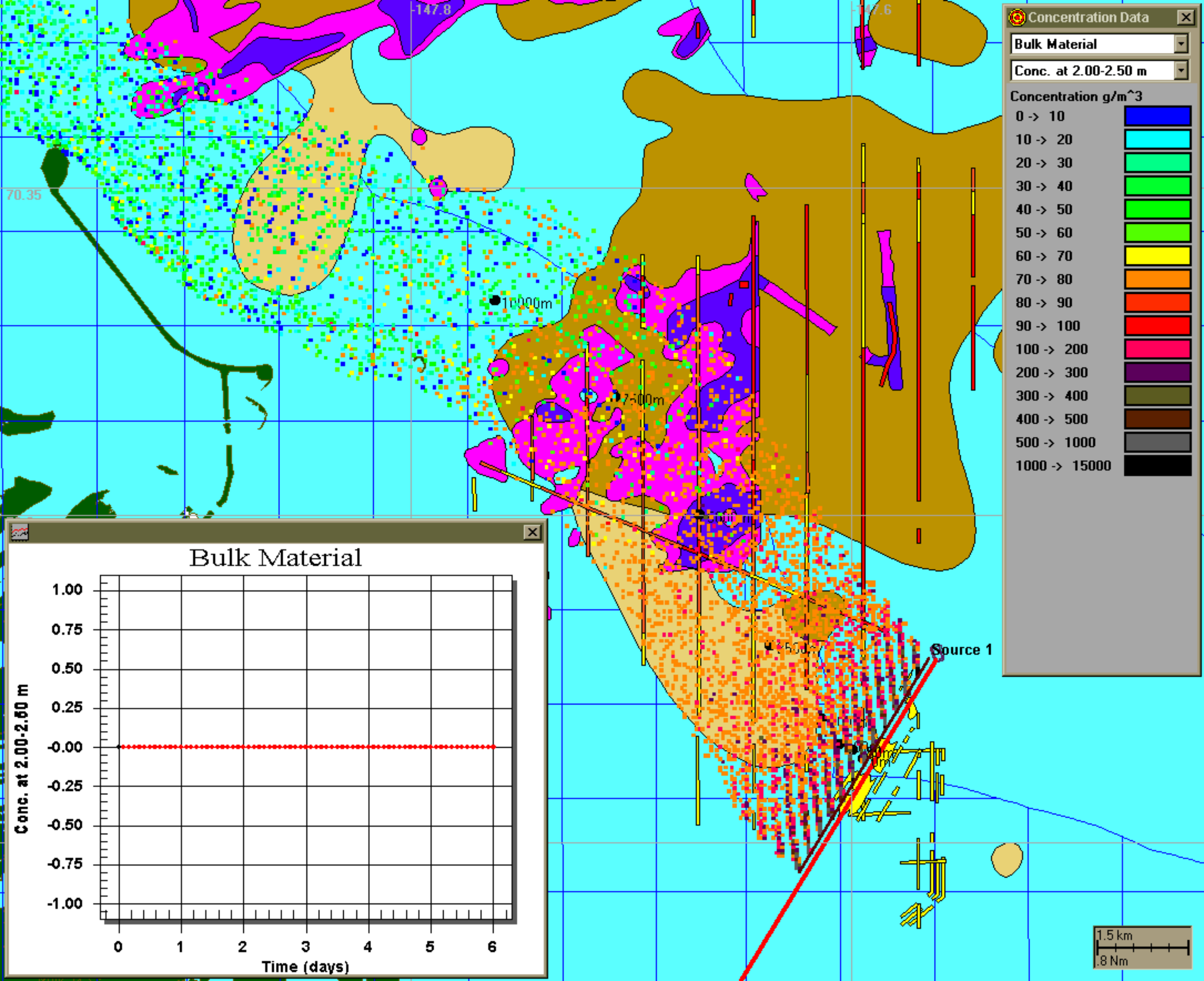

Concentration Data

Bulk Material

Conc. at 2.00-2.50 m

Concentration g/m³

0 -> 10	Blue
10 -> 20	Cyan
20 -> 30	Light Green
30 -> 40	Green
40 -> 50	Bright Green
50 -> 60	Yellow-Green
60 -> 70	Yellow
70 -> 80	Orange
80 -> 90	Red-Orange
90 -> 100	Red
100 -> 200	Magenta
200 -> 300	Purple
300 -> 400	Olive
400 -> 500	Brown
500 -> 1000	Grey
1000 -> 15000	Black

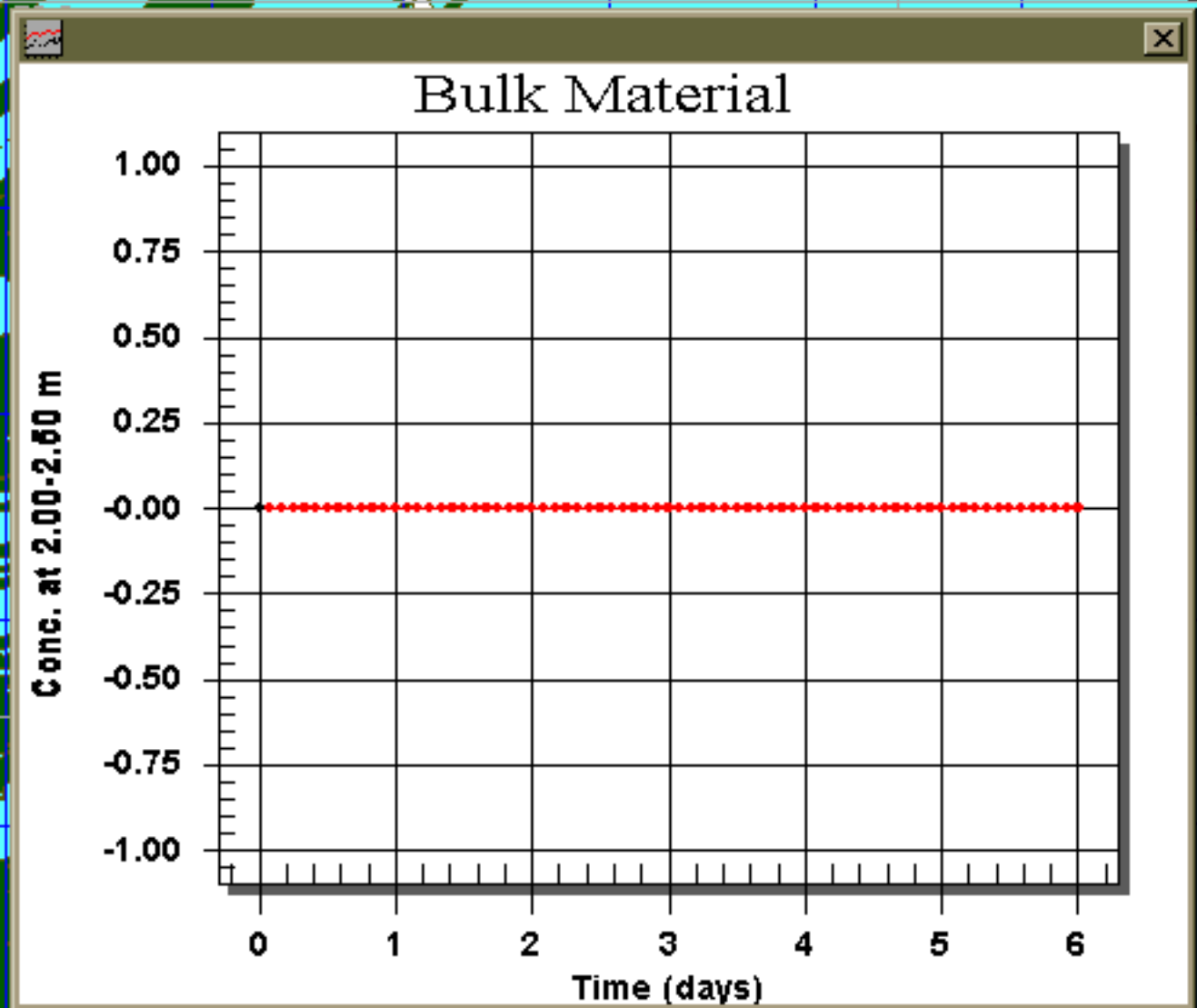

1.5 km
0.8 Nm

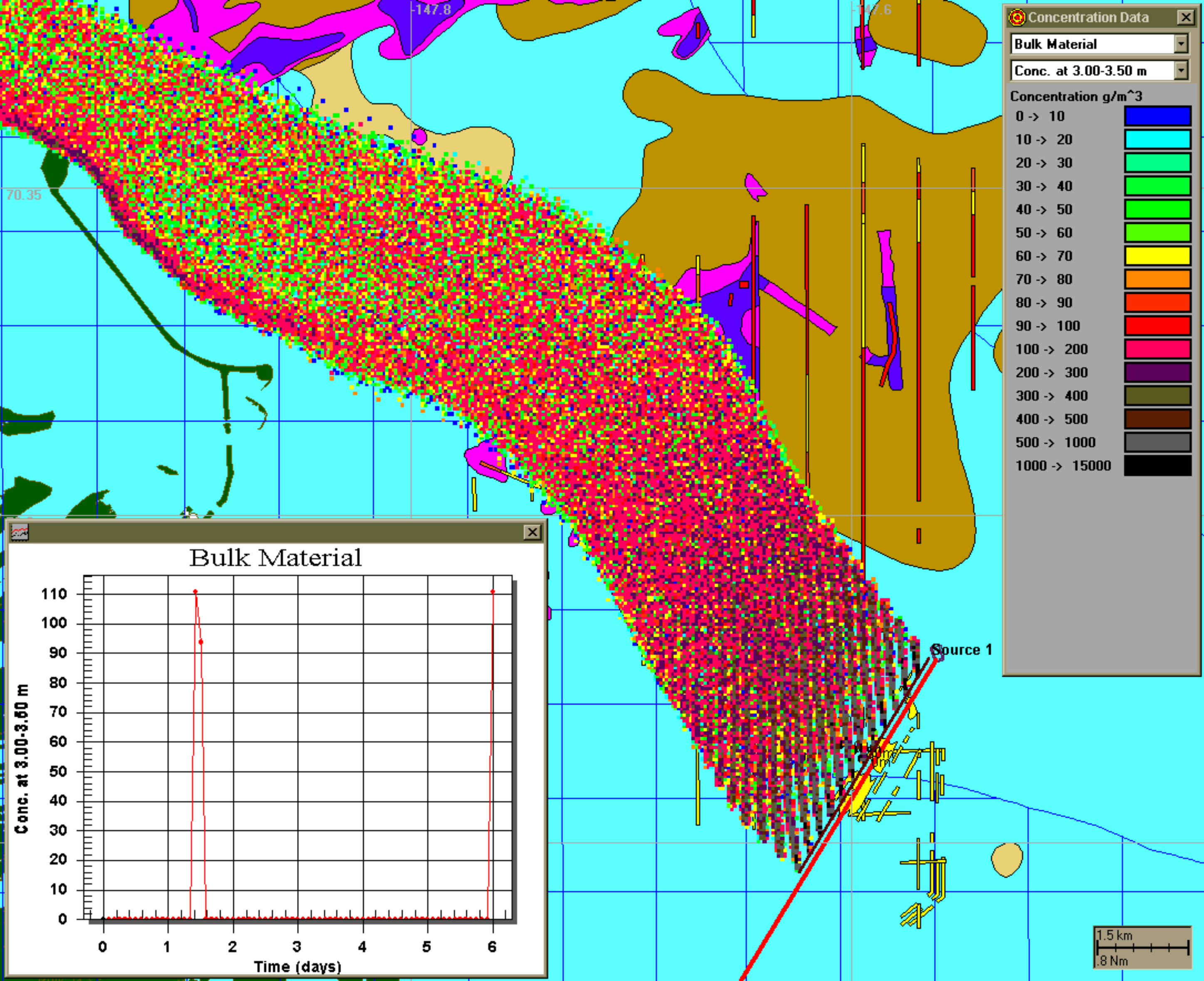

Concentration Data

Bulk Material

Conc. at 3.00-3.50 m

Concentration g/m^3

0 -> 10	Blue
10 -> 20	Cyan
20 -> 30	Light Green
30 -> 40	Green
40 -> 50	Bright Green
50 -> 60	Yellow-Green
60 -> 70	Yellow
70 -> 80	Orange
80 -> 90	Red-Orange
90 -> 100	Red
100 -> 200	Pink
200 -> 300	Purple
300 -> 400	Olive
400 -> 500	Brown
500 -> 1000	Grey
1000 -> 15000	Black

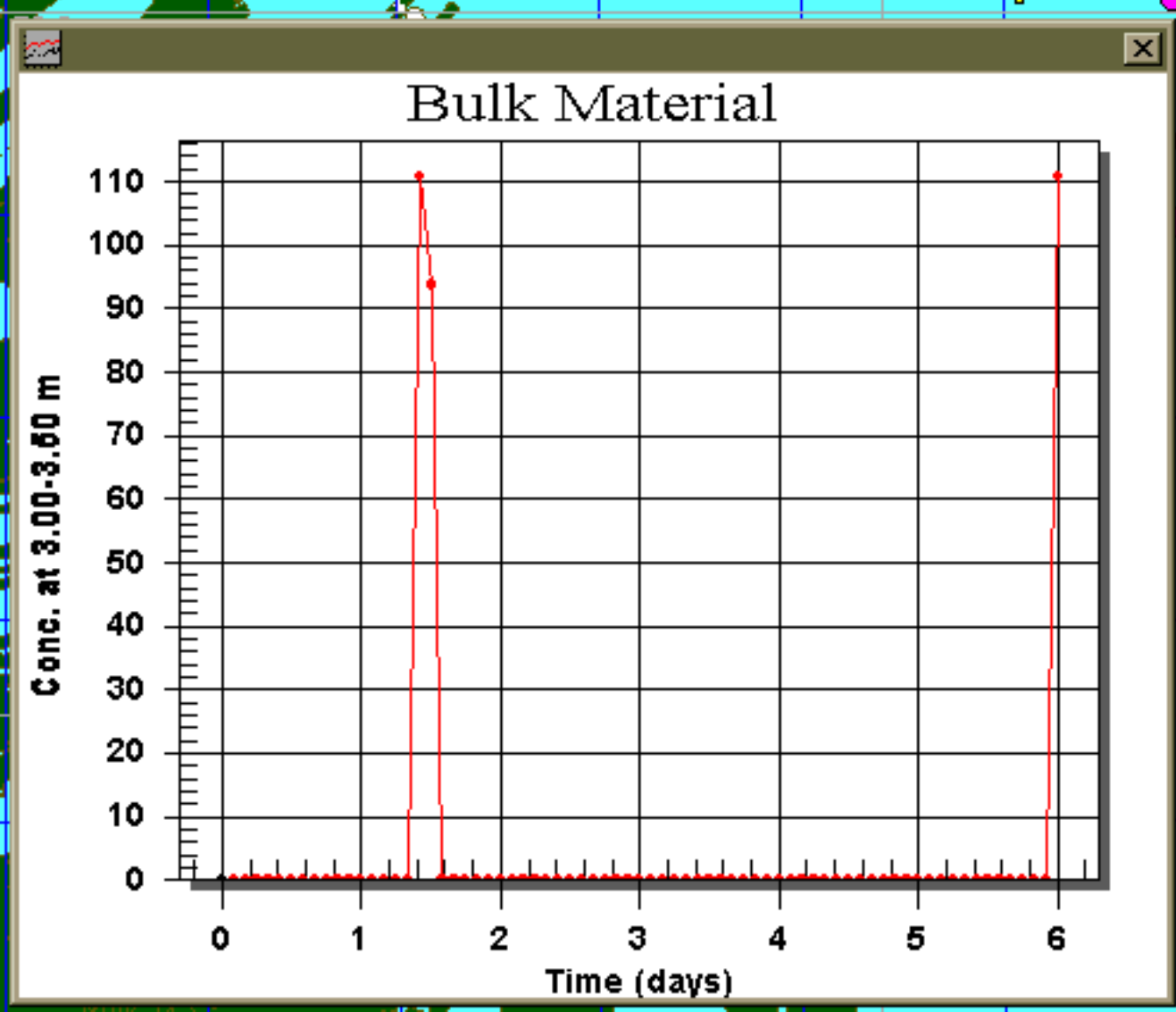

1.5 km
0.8 Nm

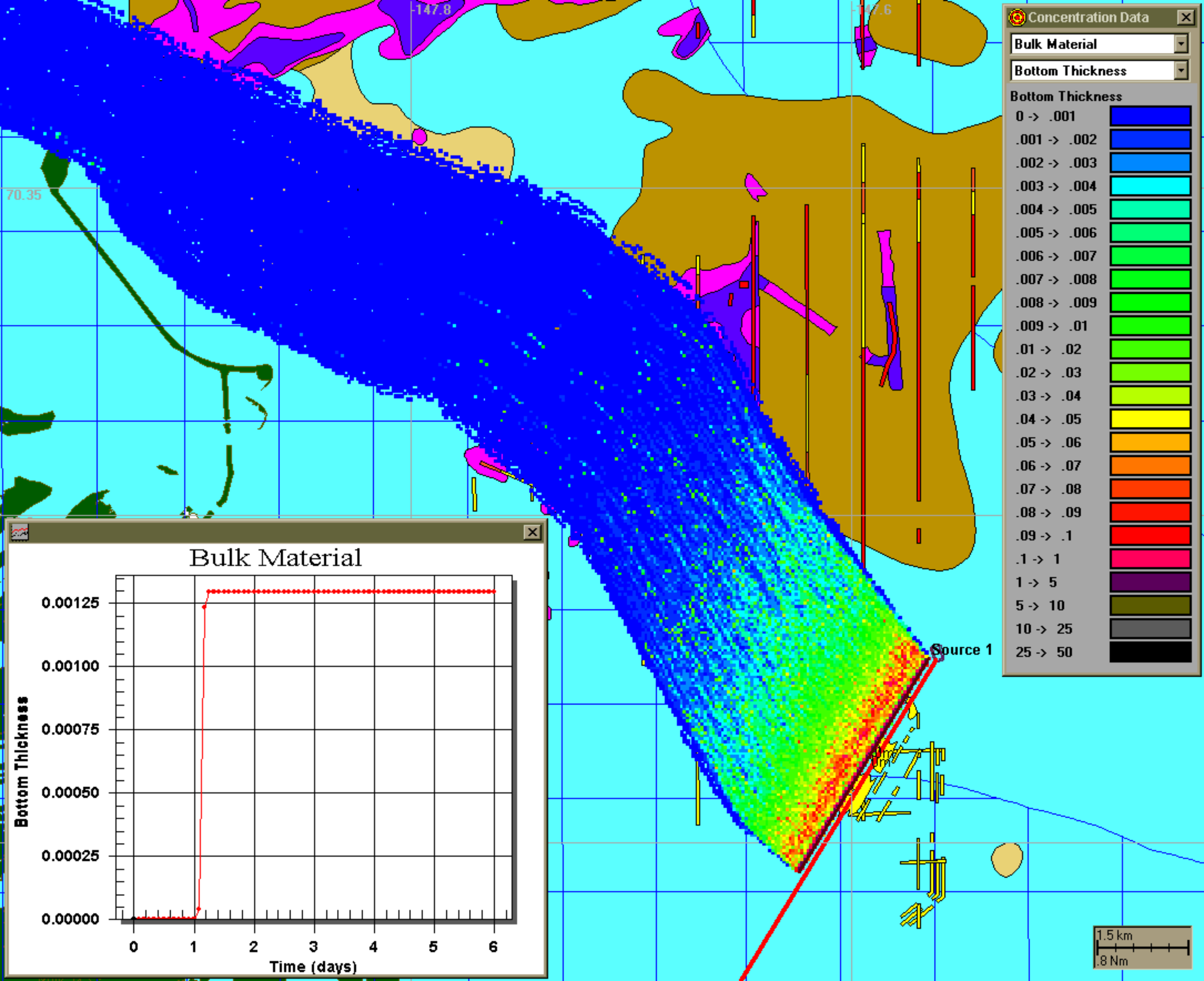

Bulk Material

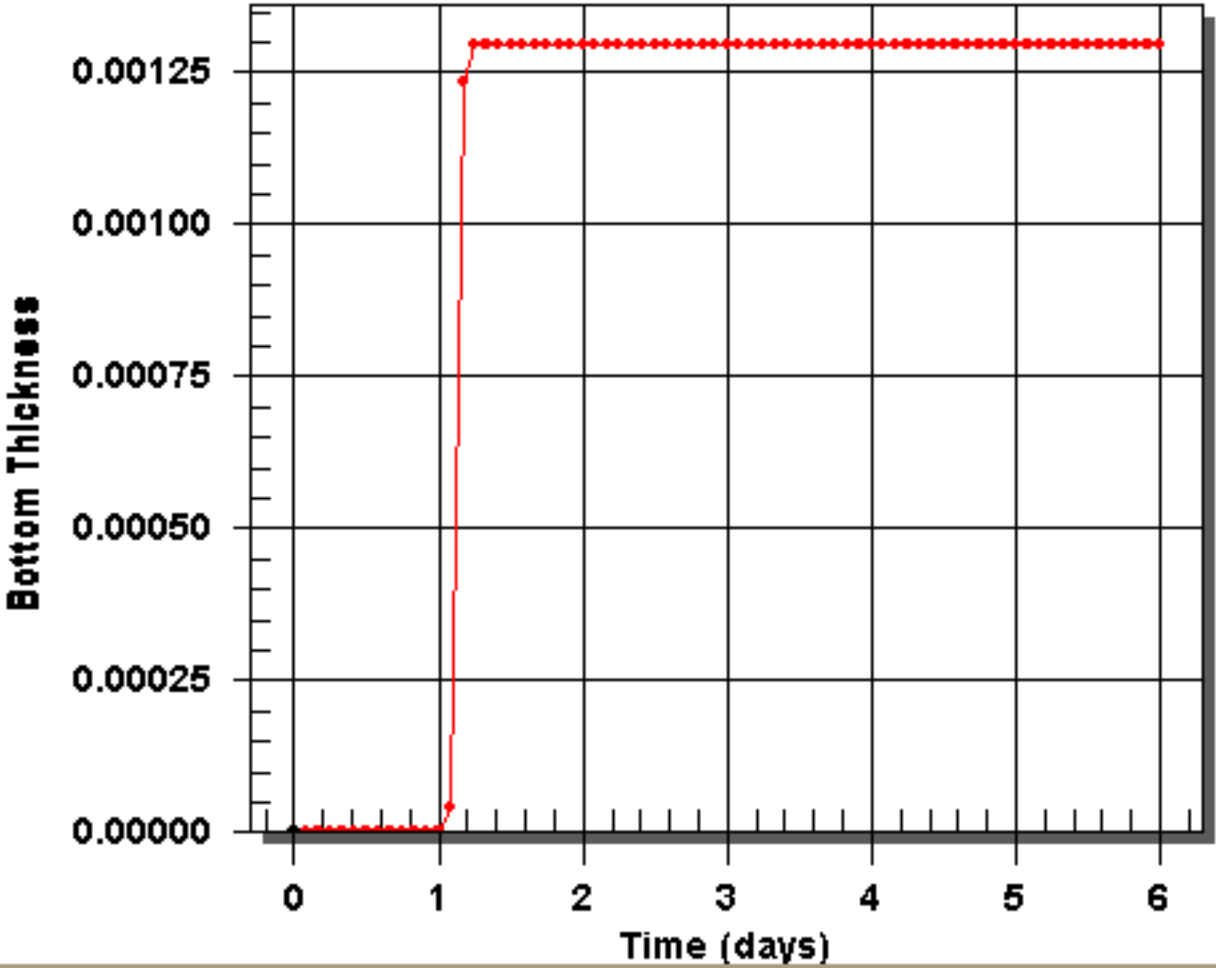

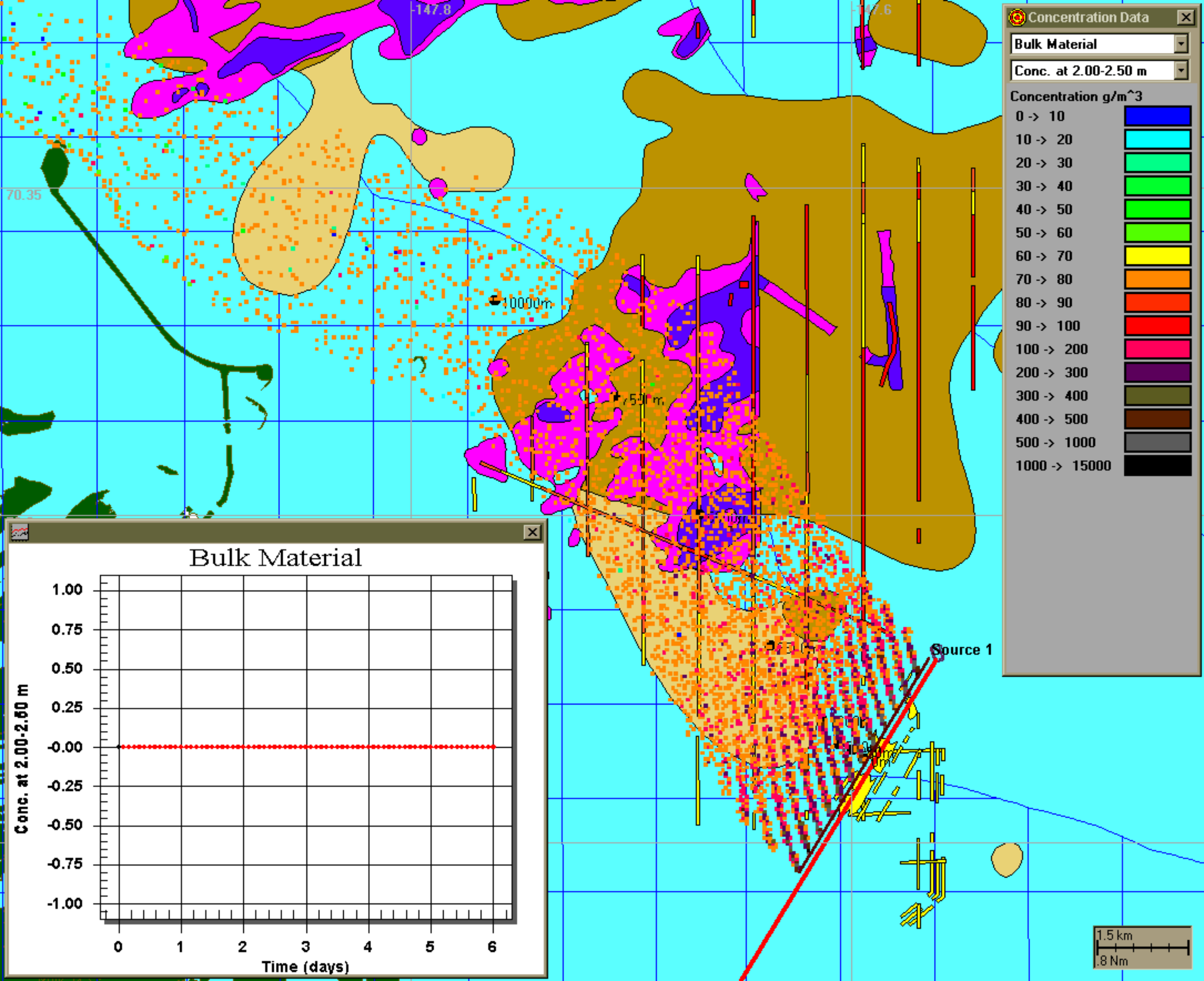

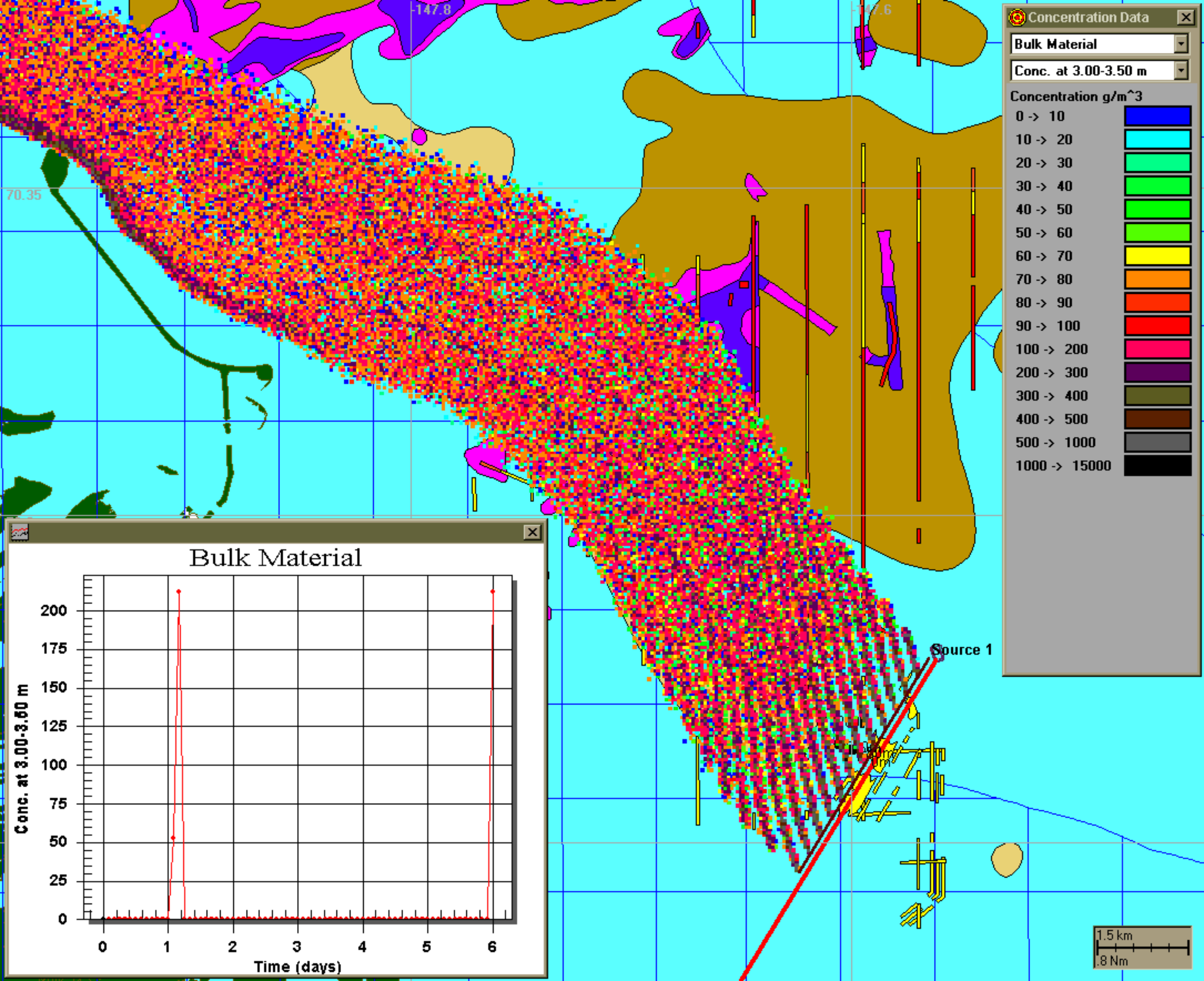

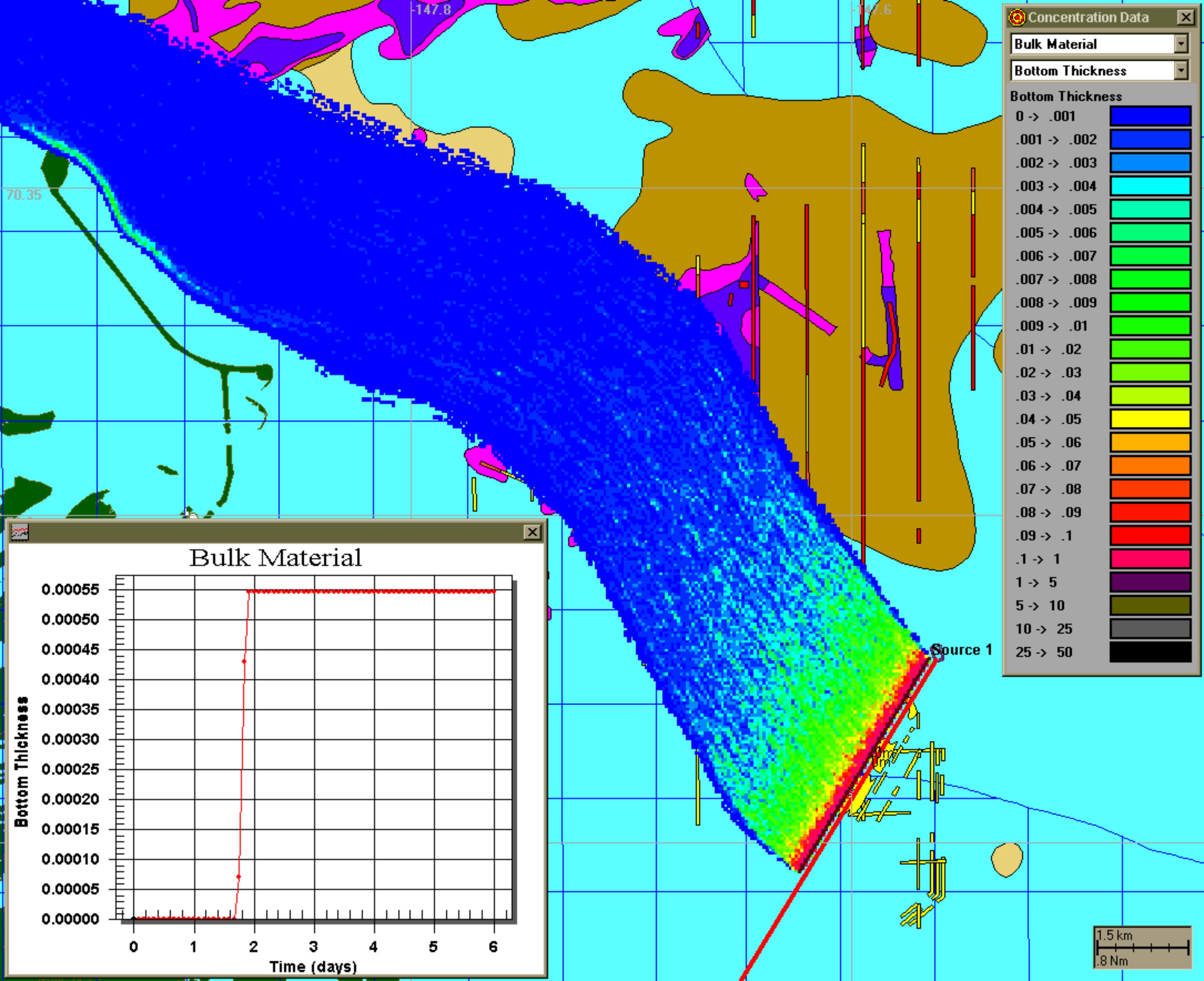

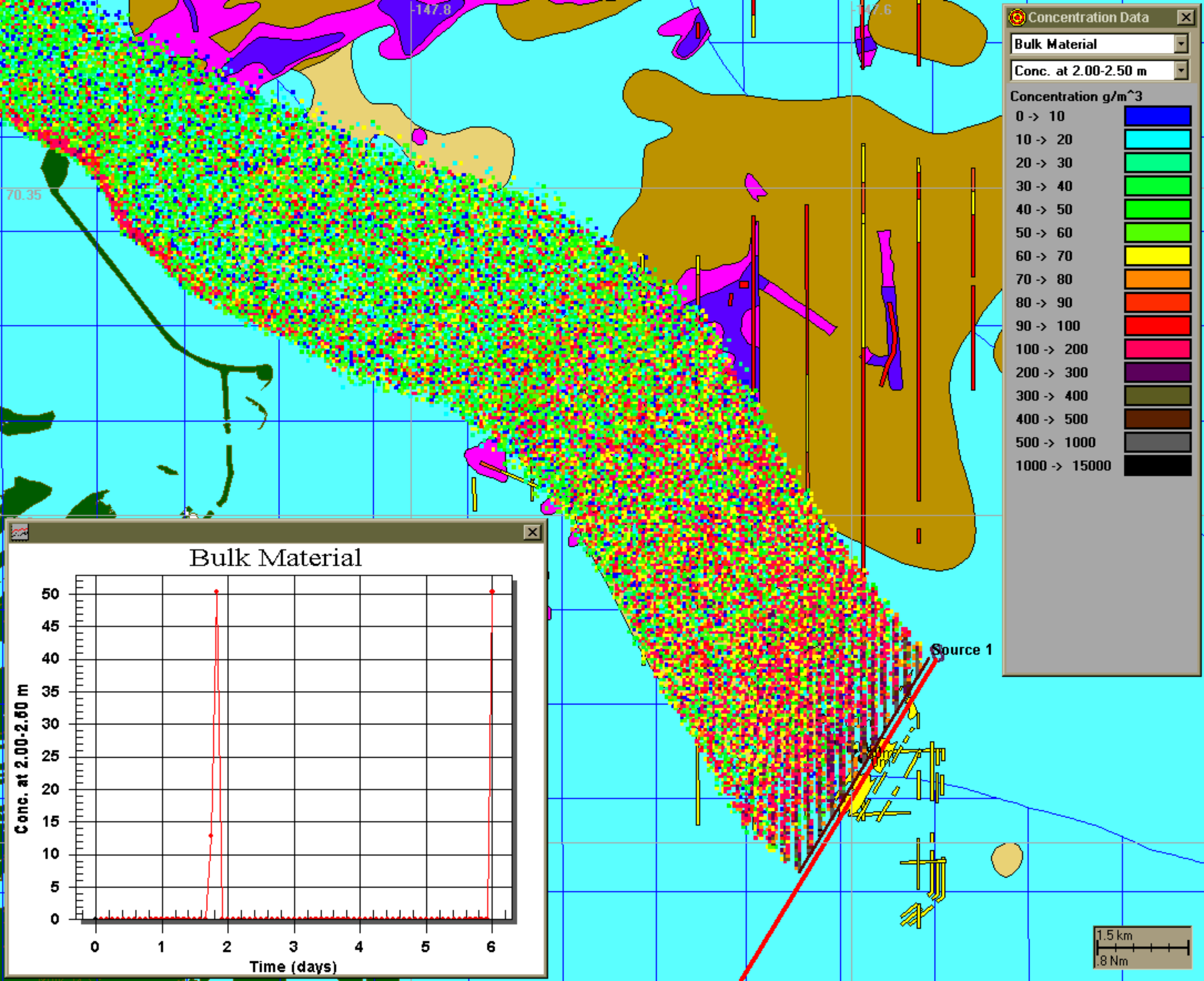

Concentration Data

Bulk Material

Conc. at 2.00-2.50 m

Concentration g/m³

0 -> 10	Blue
10 -> 20	Cyan
20 -> 30	Light Green
30 -> 40	Green
40 -> 50	Bright Green
50 -> 60	Yellow-Green
60 -> 70	Yellow
70 -> 80	Orange
80 -> 90	Red-Orange
90 -> 100	Red
100 -> 200	Pink
200 -> 300	Purple
300 -> 400	Olive
400 -> 500	Brown
500 -> 1000	Grey
1000 -> 15000	Black

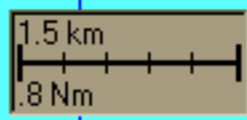
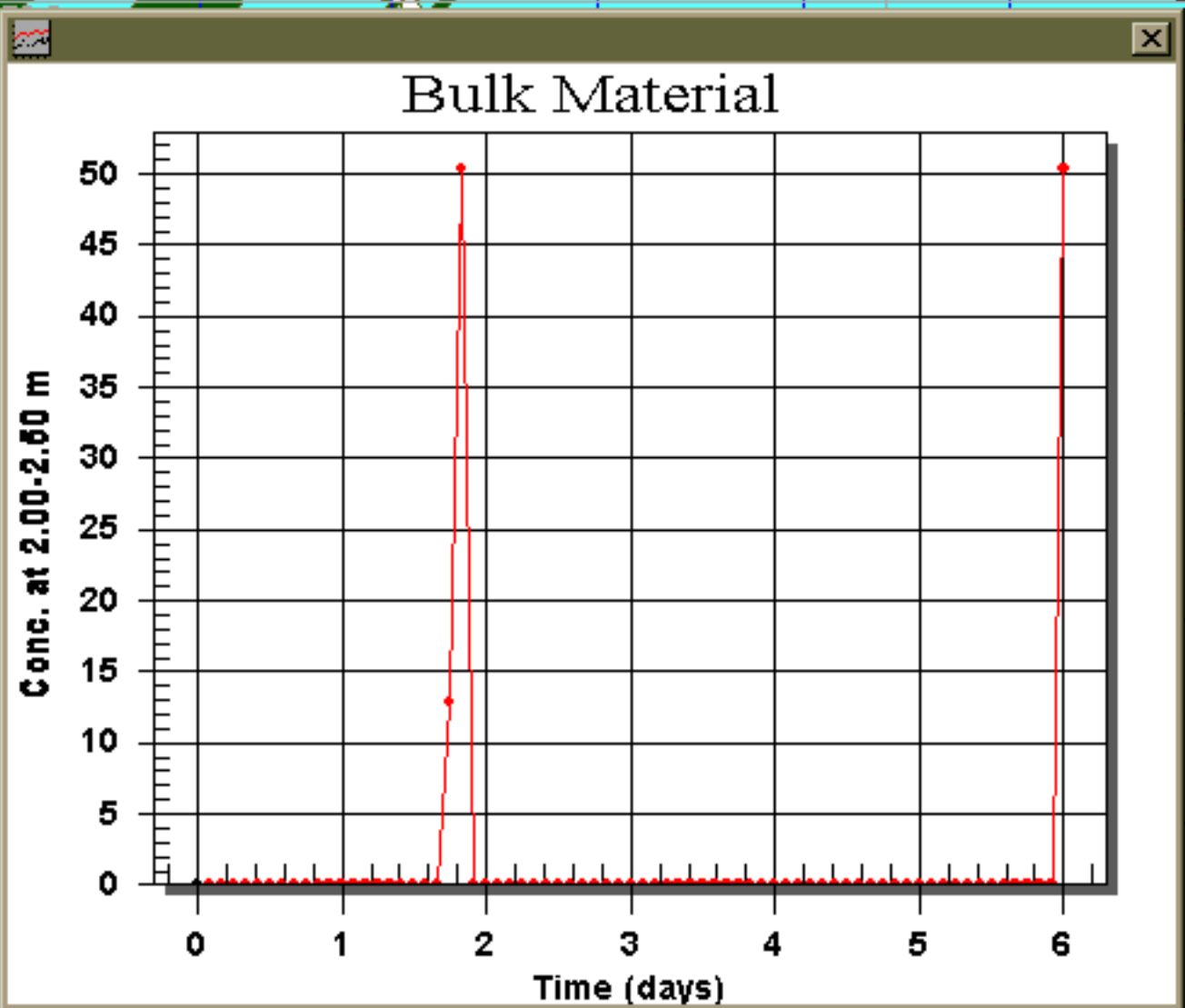

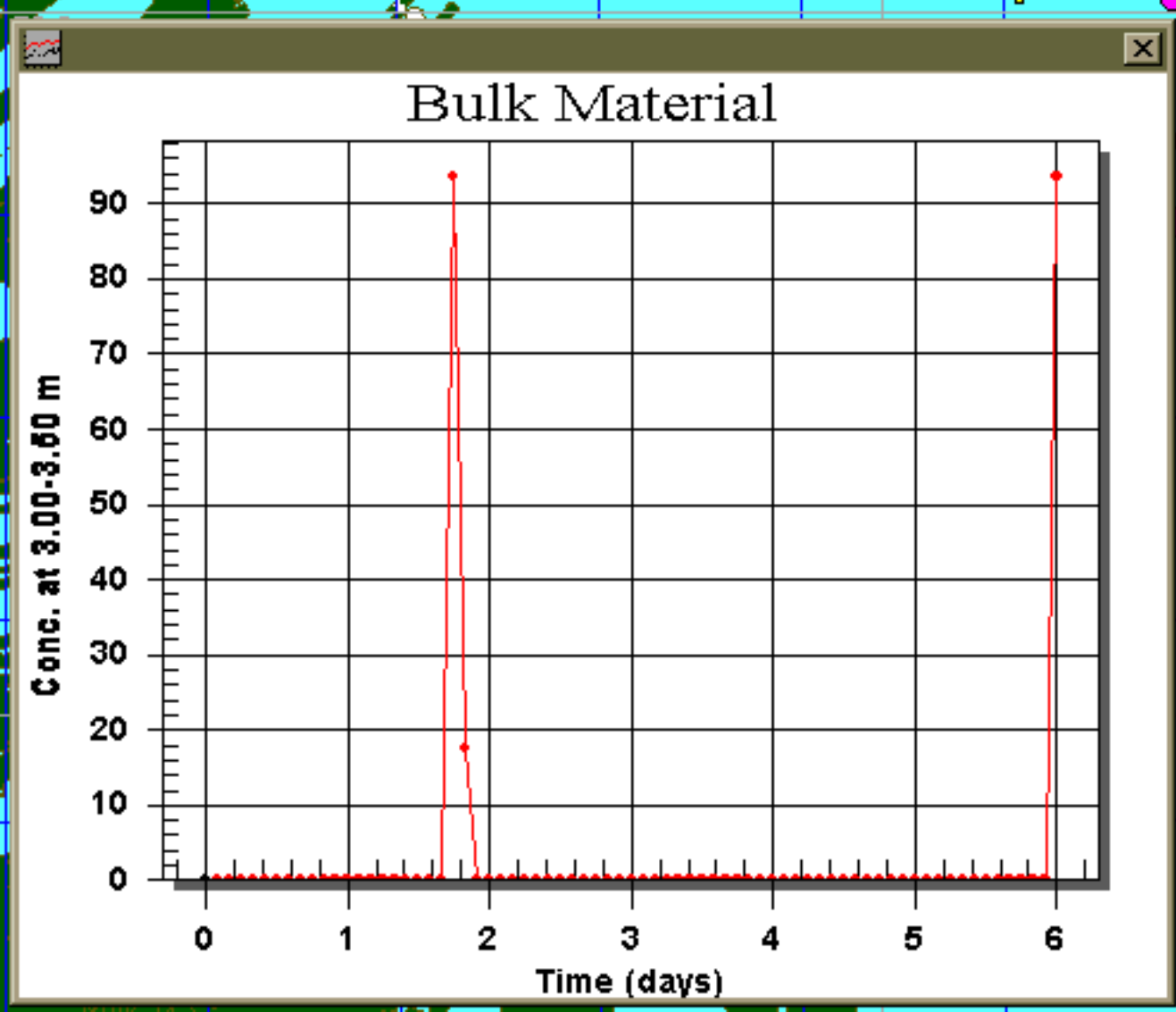
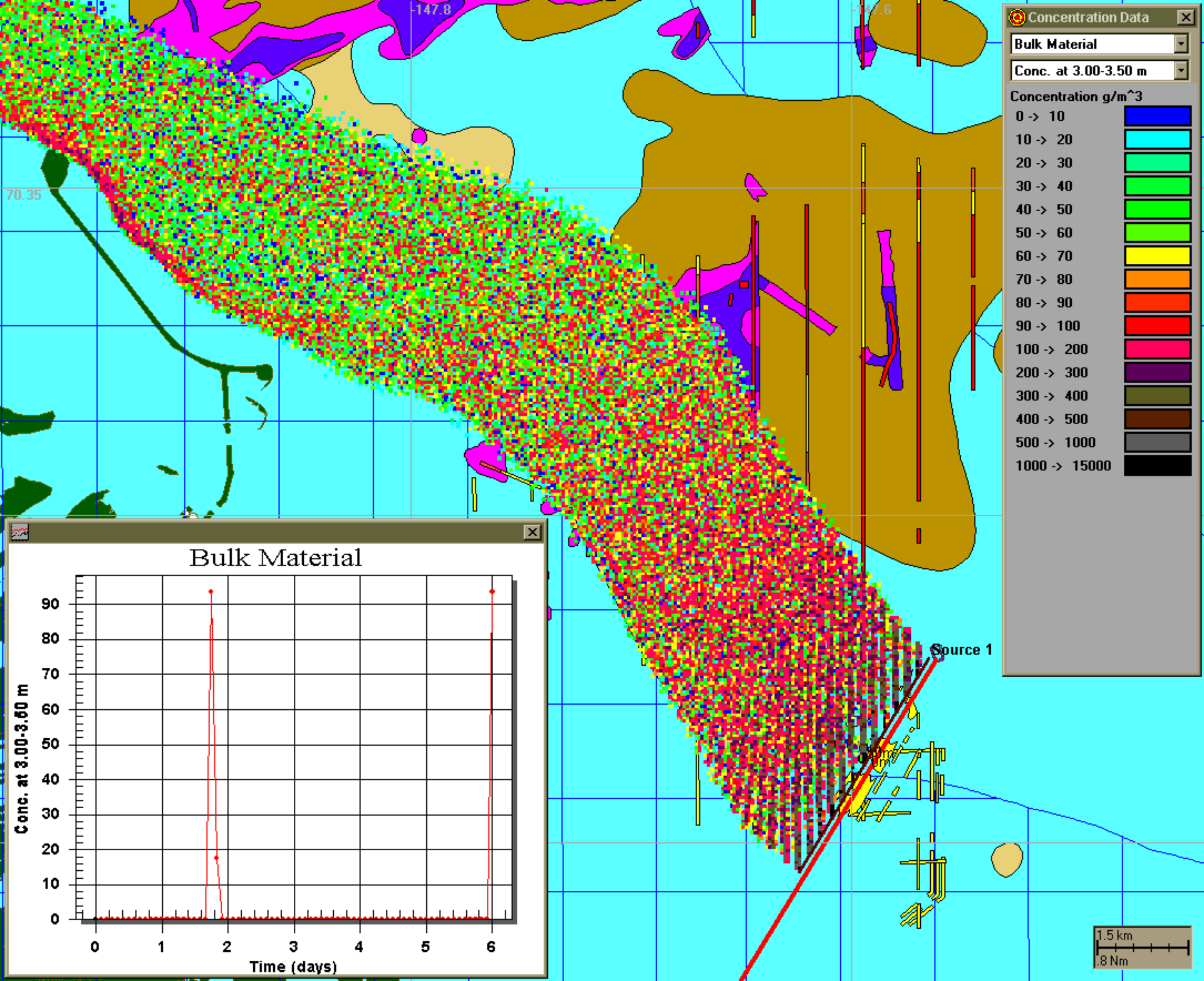

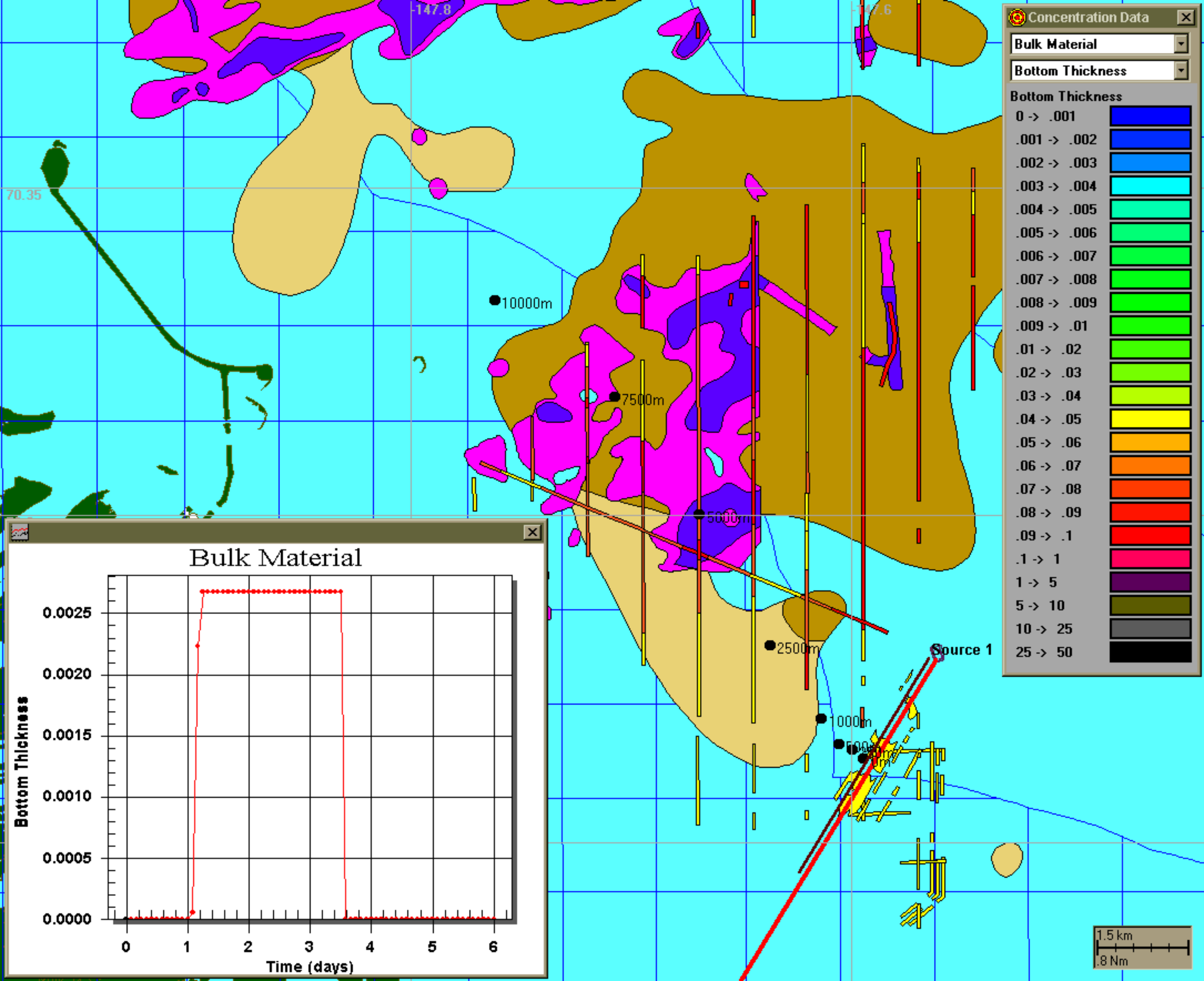

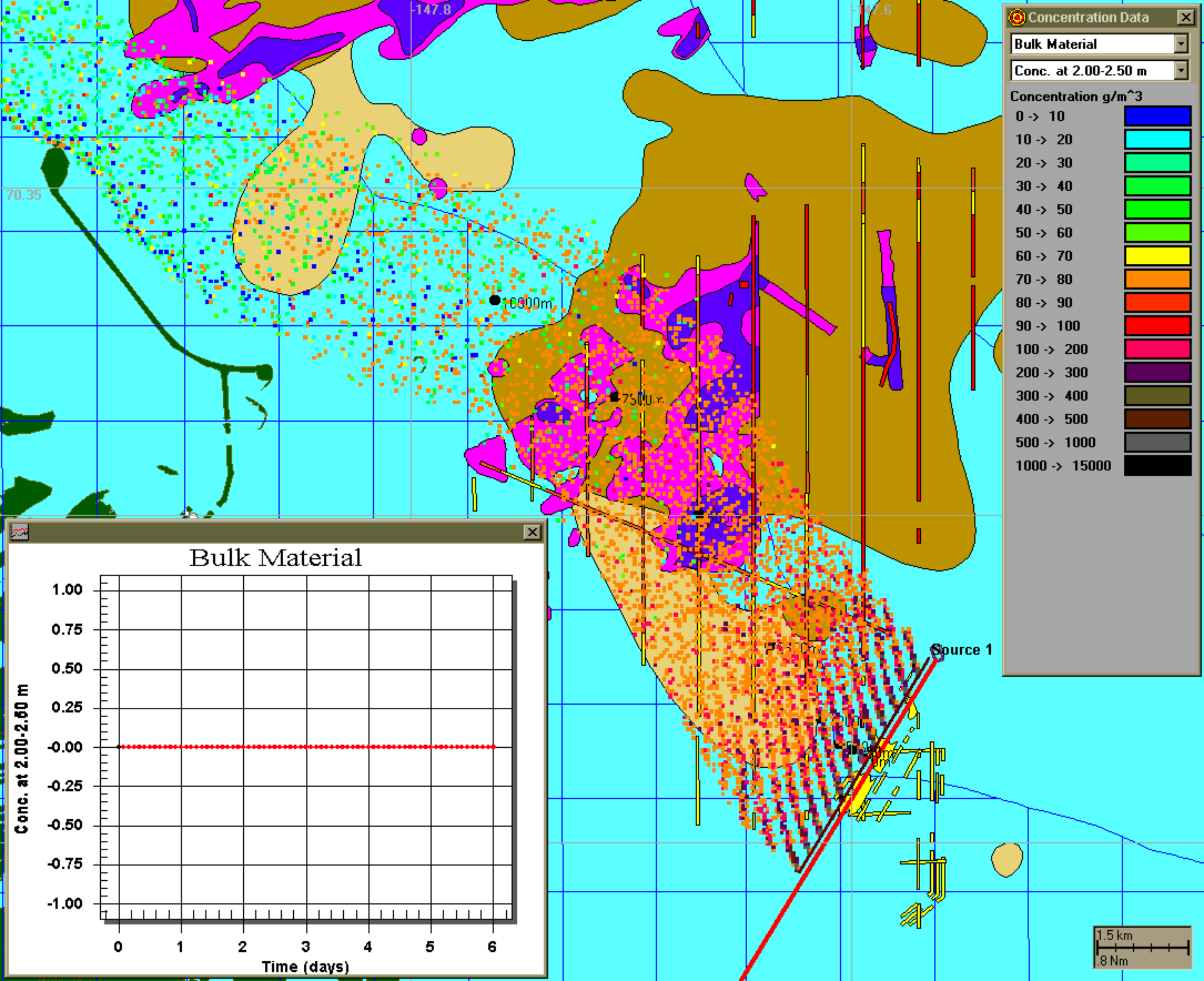

Concentration Data

Bulk Material

Conc. at 2.00-2.50 m

Concentration g/m^3

0 -> 10	Blue
10 -> 20	Cyan
20 -> 30	Light Green
30 -> 40	Green
40 -> 50	Yellow-Green
50 -> 60	Yellow
60 -> 70	Orange
70 -> 80	Red-Orange
80 -> 90	Red
90 -> 100	Dark Red
100 -> 200	Magenta
200 -> 300	Purple
300 -> 400	Dark Purple
400 -> 500	Black
500 -> 1000	Grey
1000 -> 15000	Dark Grey

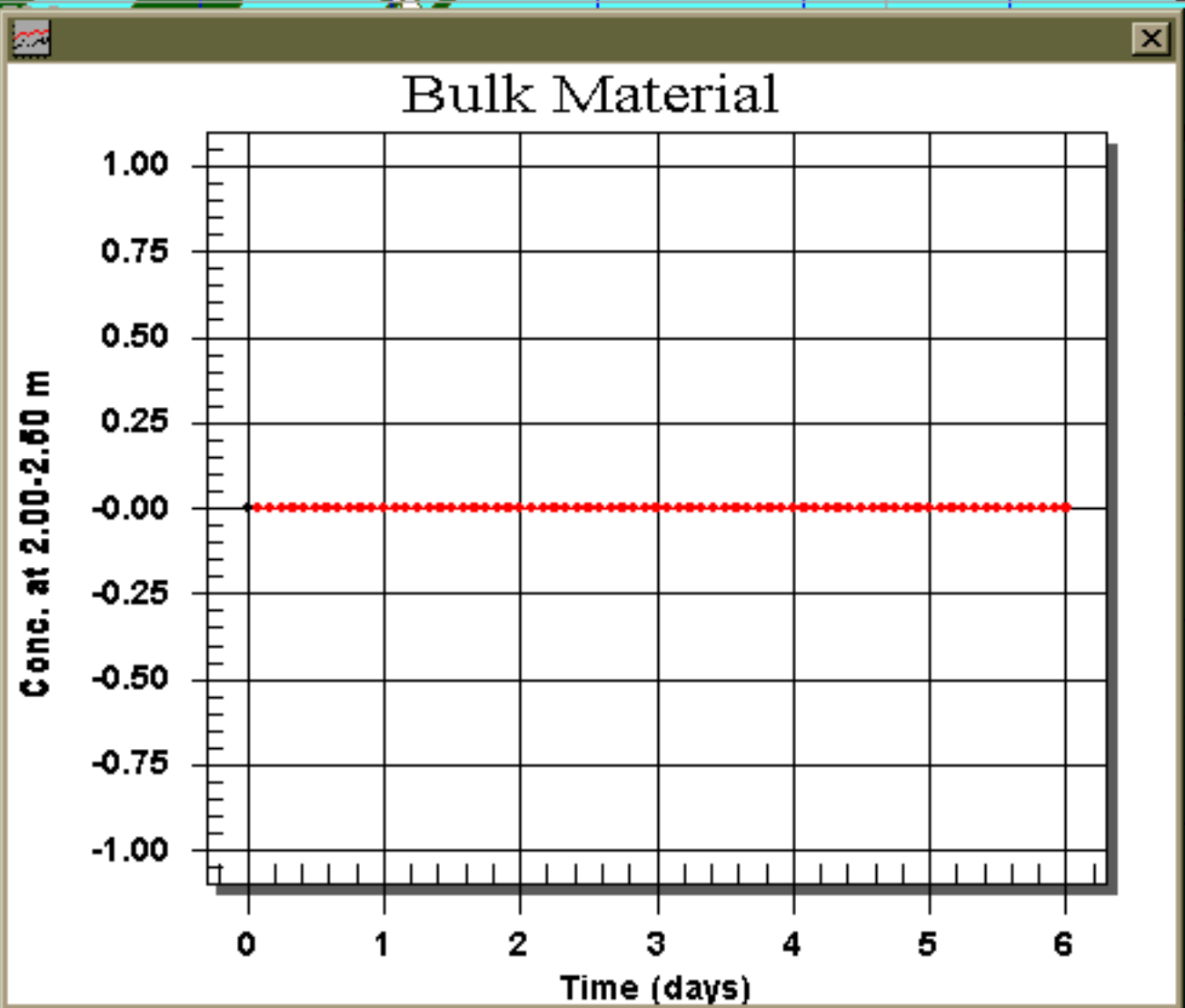

1.5 km
0.8 Nm

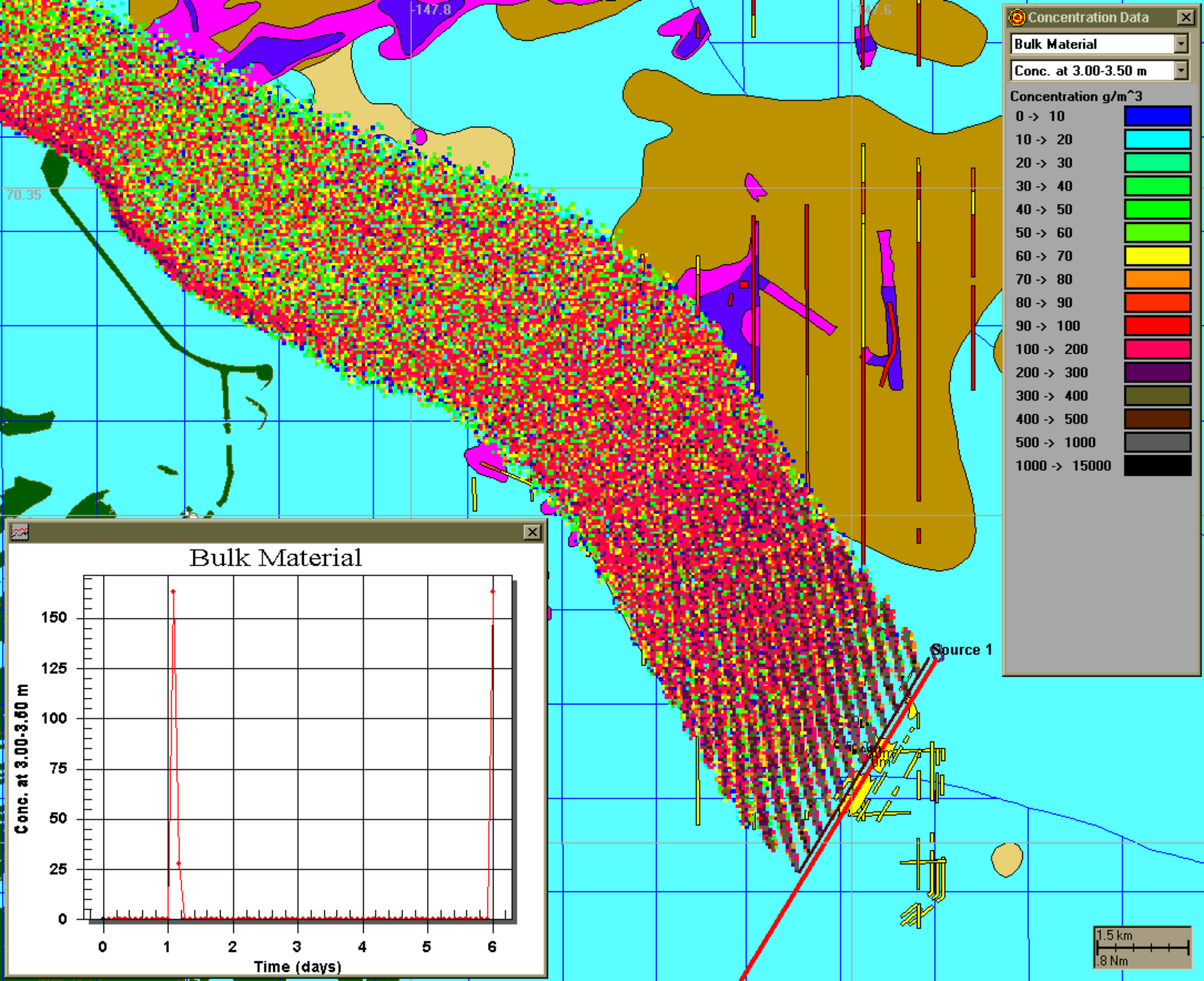

Concentration Data

Bulk Material

Conc. at 3.00-3.50 m

Concentration g/m^3

0 -> 10	Blue
10 -> 20	Cyan
20 -> 30	Light Green
30 -> 40	Green
40 -> 50	Bright Green
50 -> 60	Yellow-Green
60 -> 70	Yellow
70 -> 80	Orange
80 -> 90	Red-Orange
90 -> 100	Red
100 -> 200	Pink
200 -> 300	Purple
300 -> 400	Olive
400 -> 500	Brown
500 -> 1000	Grey
1000 -> 15000	Black

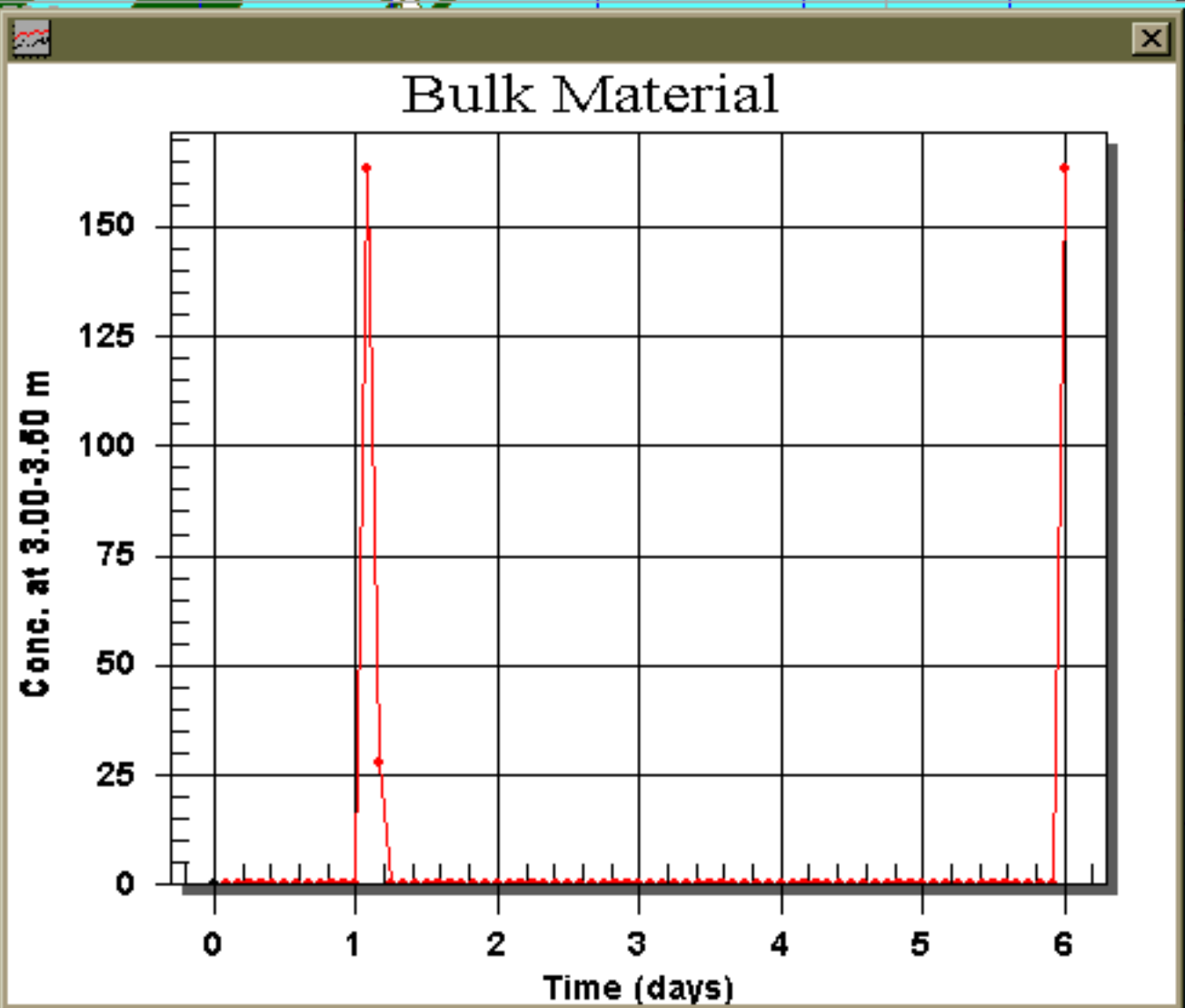

1.5 km
0.8 Nm



Description of the SSFATE Numerical Modeling System

PURPOSE: This technical note describes the numerical modeling system SSFATE (Ssuspended Sediment FATE), which is being developed to compute suspended sediment fields resulting from dredging operations. Both theoretical aspects of the computations made within SSFATE and application aspects of the shell-based personal computer program are discussed.

BACKGROUND: SSFATE was developed in response to a need for tools to assist dredging project managers confronted by requests for environmental windows. Environmental windows, intended to protect biological resources or their habitats, are requested during the interagency coordination process for dredging projects (Reine, Dickerson, and Clarke 1998). In many cases, decisions regarding environmental windows must be based on limited technical information because potential impacts are linked to a host of site- and project-specific factors. For example, navigation dredging operations in different reaches of the same waterway may pose risks to different resources, or potential impacts may vary dependent on the type of dredge plant involved. Few tools exist to evaluate such concerns early in the environmental window negotiation process. Consequently, a general inability to address “What if” questions associated with given dredging project scenarios tends to ensure that recommended environmental windows are conservative, and perhaps over-restrictive (Reine, Dickerson, and Clarke 1998).

Some of the most frequently asked “What if” questions during dredging project coordination are related to resuspension and dispersion of sediments at the dredging site. Suspended sediments are a primary concern of resource agencies, as exposure of aquatic organisms to elevated suspended sediment concentrations is perceived to be a major source of detrimental impact. Likewise, redeposition of suspended sediments can be a significant concern if sensitive bottom-dwelling organisms (e.g., oysters or sea grasses) are present in the vicinity of a dredging project. Accurate information on the spatial dynamics of dredge-induced suspended sediments is therefore a critical necessity in establishing the overall need for protective windows.

Environmental windows are associated with a majority of dredging projects in many U.S. Army Corps of Engineers Districts (Reine, Dickerson, and Clarke 1998). However, presently available modeling tools for predicting suspended sediment behavior were not designed with environmental windows negotiation in mind. For logistical reasons, models that require complicated, extensive hydrodynamic databases, grid building, or high-end computer support are not suitable. These models are more appropriate for large, controversial projects. Clearly, funding constraints alone would hinder application of expensive numerical models to the evaluation of numerous environmental windows.

To be truly effective as a dredging project management tool with respect to windows, models should be capable of running multiple simulations in a relatively short span of time so that a number of alternative dredging scenarios can be evaluated to determine those with the least probabilities of

detrimental impacts. An ability to display the dispersion of suspended sediments from a dredging site in a format that can be merged with known distributions of biological resources is a requirement that powerfully enhances impact assessments. Also, a “hands-on” tool that would enable the dredging project manager or resource agency representatives to specify a range of simulated scenarios and have model solutions quickly and readily available for interpretation would be a significant improvement over existing technologies.

Given these considerations, SSFATE is being developed to fulfill an obvious need for a modeling tool that can be easily customized to simulate a broad spectrum of dredging scenarios, accommodating essentially any hydrodynamic setting and most typical dredge plants. SSFATE is not intended to be an analytical tool per se, but rather a screening tool. Its utility is particularly suited for assessing the likelihood that resuspended sediments generated by a specific project would pose substantial risk to resources or habitats of concern, thereby allowing environmental windows to be appropriately applied or modified. Obviously, if SSFATE output showed negligible overlap of suspended/deposited sediments and resource distributions, the need for a stringent window to avoid conflicts would be questionable. Conversely, where output from SSFATE indicated a high probability of impact, an individual window could be accepted with a higher degree of confidence in its technical justification, and lead to consideration of other means to minimize impacts.

SYSTEM OVERVIEW: SSFATE is a versatile computer modeling system containing many features. For example, ambient currents, which are required for operation of the basic computational model, can either be imported from a numerical hydrodynamic model or drawn graphically using interpolation of limited field data. Model output consists of concentration contours in both horizontal and vertical planes, time-series plots of suspended sediment concentrations, and the spatial distribution of sediment deposited on the sea floor. In addition, particle movement can be animated over Geographic Information System (GIS) layers depicting sensitive environmental areas.

SSFATE employs a shell-based approach consisting of a color graphics based, menu-driven user interface, GIS, environmental data management tools, gridding software, and interfaces to supply input and display output data from the model. SSFATE runs on a personal computer and makes extensive use of the mouse (point/click) and pulldown menus. Data input/output is interactive and mainly graphics based. The system supports a full set of tools to allow the user to import data from standard databases, a wide variety of GISs, and other specialized plotting/analysis programs. SSFATE can be set up to operate at any dredging operation site and includes a series of mapping/analysis tools to facilitate applications. Initial setup for new locations of dredging operations can normally be accomplished in a few hours, unless numerical hydrodynamic models are run to provide flow fields. At the heart of the system is a computational model that predicts the transport, dispersion, and settling of suspended dredged material released to the water column as a result of dredging operations. An integral component of the modeling system is the specification of the sediment source strength and vertical distribution.

SSFATE SEDIMENT SOURCES: At the present time, sediment sources in SSFATE represent the introduction of sediment into the water column only as the result of a cutterhead dredge, a hopper dredge, or a clamshell dredge. The strength of each source is based on the Turbidity Generation Unit concept proposed by Nakai (1978). For the cutterhead dredge source, introduction of

suspended material is assumed to occur very near the bottom. For dredging operations using a hopper dredge, both near-bottom and near-surface sources are modeled. Near-surface sources are needed if overflow operations are performed. Clamshell dredges release material continuously as the clamshell is pulled through the water column. Thus, the vertical distribution of suspended sediment released by a clamshell dredge extends over the entire water column. In addition, since overflow operations can occur with the placement of material into a barge using a clamshell dredge, a near-surface source is also implemented for clamshell dredges. A detailed discussion of the sediment sources in SSFATE is provided in Johnson and Parchure (1999).

Simulation durations with SSFATE are not anticipated to be greater than a day or so. Thus, although the sources for cutterhead and clamshell dredges can move during the day, the greatest movement of the sediment source will occur with a hopper dredge. To account for this movement, the user specifies a line along which dredging takes place at a specified rate. When the hoppers are full, the simulated dredge moves to the placement site and releases the material. When the dredge returns to the dredging site, a new dredging line is specified. This procedure continues until the simulation is completed.

COMPUTATIONAL MODEL: Depending on the resolution of the numerical grid employed, SSFATE can make predictions very near dredging operations; however, the processes modeled are primarily far field processes in which the mean transport and turbulence associated with ambient currents dominate. Transport and dispersion of suspended material from a sediment source are predicted by a particle-based model using a random walk procedure.

The following basic equations determine the location of each particle at the next time-step in the simulation:

$$X^{n+1} = X^n + DX \tag{1}$$

$$Y^{n+1} = Y^n + \Delta Y \tag{2}$$

$$Z^{n+1} = Z^n + \Delta Z \tag{3}$$

where

$$\Delta X = U\Delta T + L_x \tag{4}$$

$$\Delta Y = V\Delta T + L_y \tag{5}$$

$$\Delta Z = Ws_i\Delta T + L_z \tag{6}$$

and

X, Y, Z = location of particle in the x-, y-, and vertical directions, respectively

U, V = mean ambient velocity in the x-, and y-directions, respectively

ΔT = time-step

Ws_i = settling velocity of particle class i

L_x, L_y, L_z = particle diffusion distance in the x-, y-, z-directions, respectively

Particle diffusion is assumed to follow a simple random walk process. A diffusion distance defined as the square root of the product of an input diffusion coefficient and the time-step is decomposed into X and Y displacements via a random direction function. The Z diffusion distance is scaled by a random positive or negative direction. The equations for the horizontal and vertical diffusion displacements are written as:

$$L_x = \sqrt{D_h \Delta T} \cos(2\pi R) \quad (7)$$

$$L_y = \sqrt{D_h \Delta T} \sin(2\pi R) \quad (8)$$

$$L_z = \sqrt{D_z \Delta T} (0.5 - R) \quad (9)$$

where

D_h, D_z = horizontal and vertical diffusion coefficients, respectively

R = random real number between 0 and 1

The particle model allows the user to predict the transport and fate of classes of settling particles, e.g., sands, silts, and clays. The fate of multicomponent mixtures of suspended sediments is predicted by linear superposition. The particle-based approach is extremely robust and independent of the grid system. Thus, the method is not subject to artificial diffusion near sharp concentration gradients and is easily interfaced with all types of sediment sources. For example, although the basic purpose of SSFATE is to aid in answering questions concerning the need for environmental windows associated with a dredging operation, models such as STFATE (Short-Term FATE) (Johnson and Fong 1995), which computes the near field dynamics of a placement operation, could be used to provide the sediment source associated with placement operations. In addition, under the Dredging Operations and Environmental Research (DOER) Program, a near field model is being developed to answer mixing zone questions connected with the placement of dredged material by a pipeline. Plans call for implementing results from the pipeline model as a sediment source in SSFATE.

Equations 4-6 show that the components of the ambient current field are required to transport the sediment particles. SSFATE provides two options for the user. The simplest option is to input limited field data, e.g., the magnitude of the tidal current, its period, and its principal direction. An interpolation scheme described by Cressman (1959) is then employed to “paint” a flow field over a rectangular water-land numerical grid. This flow field is then used to provide the (U, V) components of the ambient current in Equations 4 and 5. With this option, there is no vertical component of the flow field. The second option is for the user to import a time-varying,

three-dimensional (3-D) flow field generated by a numerical hydrodynamic model such as CH3D (Curvilinear Hydrodynamics in 3 Dimensions) developed by Johnson et al. (1991).

As implied by these two options, two types of grids are allowed in SSFATE. If currents are painted, the grid is rectangular with rectangular cells that are either land or water cells. Figure 1 shows an example of such a grid generated for upper Narragansett Bay, Rhode Island.

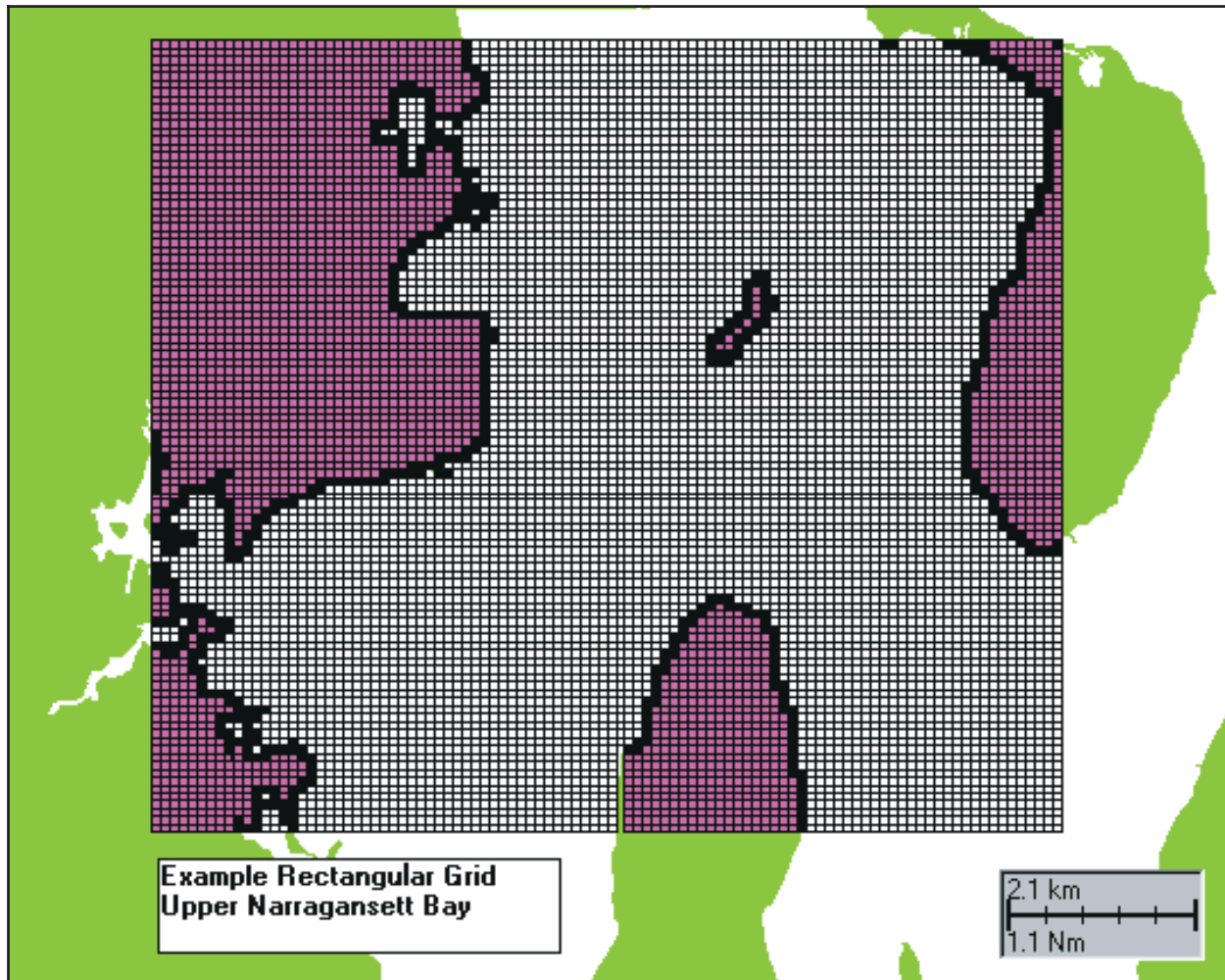

Figure 1. Rectangular land-water grid supported by SSFATE, upper Narragansett Bay, Rhode Island

However, if 3-D hydrodynamics are imported, SSFATE supports either a rectangular or a boundary-fitted curvilinear grid such as shown in Figure 2, again for the upper Narragansett Bay.

In addition to transport and dispersion, sediment particles also settle at some rate from the water column. Settling of mixtures of particles, some of which may be cohesive in nature, is a complicated process with the different size classes interacting; i.e., the settling of one particle type is not independent of the other types. The procedure that has been implemented in SSFATE is described in the following paragraphs, taken from Teeter (in review).

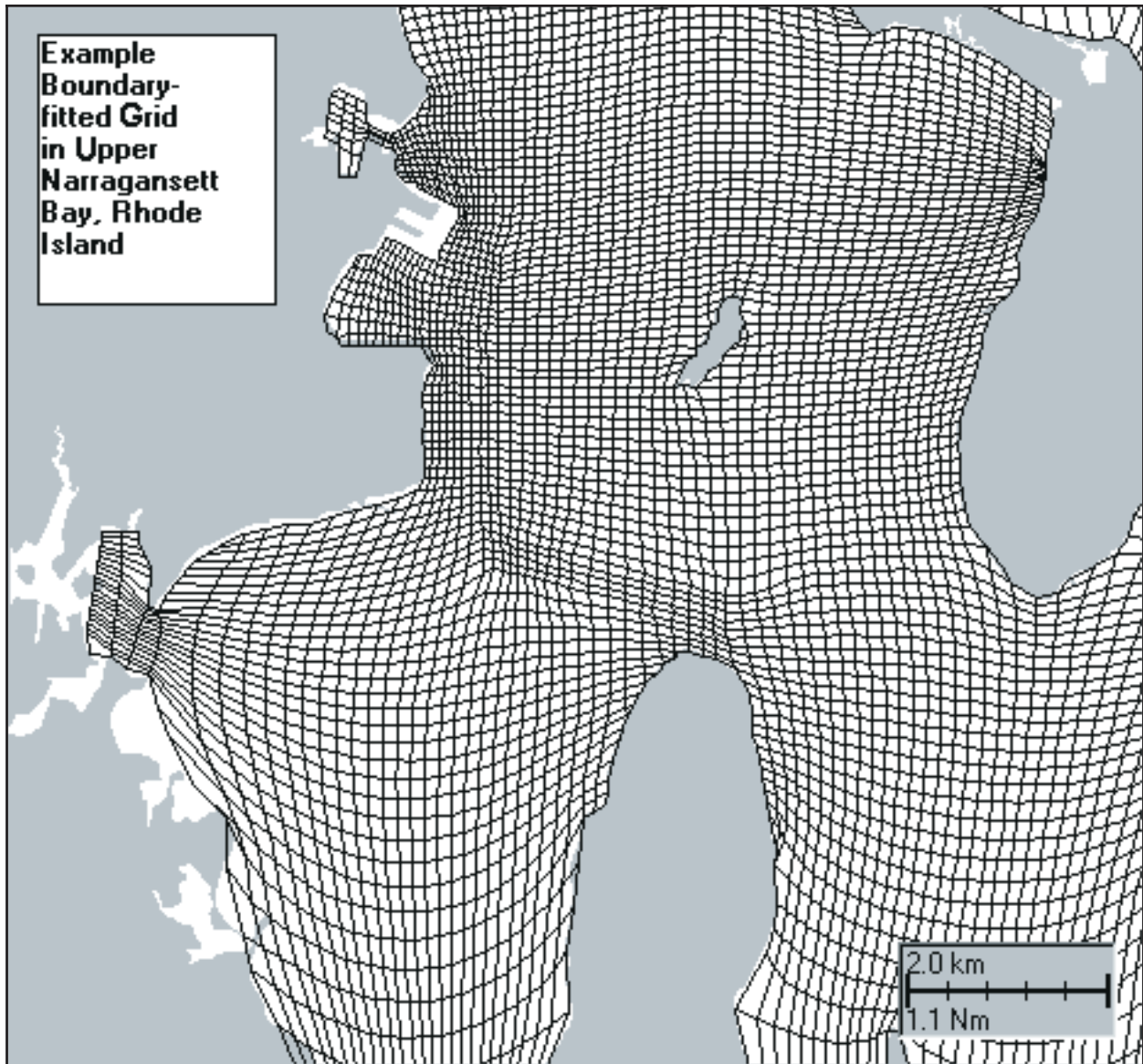

Figure 2. Boundary-fitted grid supported by SSFATE, upper Narragansett Bay, Rhode Island

At the end of each time-step the concentration of each sediment class C_i as well as the total concentration C is computed on a concentration numerical grid. The size of all grid cells is the same relative to one another and to time, with the total number of cells increasing as the suspended sediment plume moves away from the dredging source. The settling velocity of each particle size class is computed from

$$W_{s_i} = a \left(\frac{C}{C_{ul}} \right)^{n_i} \quad (10)$$

$$a = \frac{1}{C} \sum_i a_i C_i \quad (11)$$

$$\bar{C}_{ul} = \frac{1}{C} \sum_i C_{ul_i} C_i \quad (12)$$

$$\bar{C}_{ll} = \frac{1}{C} \sum_i C_{ll_i} C_i \quad (13)$$

and C_{ul_i} and C_{ll_i} are the nominal upper and lower concentration limits, respectively, for enhanced settling of grain class i .

If $C \geq \bar{C}_{ul}$ then

$$W_{s_i} = a \quad (14)$$

whereas, if $C \leq \bar{C}_{ll}$ then

$$W_{s_i} = a \left(\frac{\bar{C}_{ll}}{\bar{C}_{ul}} \right)^{n_i} \quad (15)$$

Typical values of C_{ll_i} , C_{ul_i} , a_i , and n_i for four size classes are given in Table 1.

The next step in the settling computations is to compute a bottom shear

stress τ using either the painted currents or the imported currents. A deposition probability P_i is then computed for each size class as follows:

a. For size class 0 (clay), the following are used:

$$P_0 = \left(1 - \frac{\tau}{\tau_{cd}} \right), \text{ if } \tau < \tau_{cd} \quad (16)$$

$$P_0 = 0, \text{ if } \tau > \tau_{cd} \quad (17)$$

where τ_{cd} is the critical shear stress for deposition for the clay fraction.

Table 1					
Typical values of coefficients					
Class	Size, microns	C_{ll_i}, g/cc	C_{ul_i}, g/cc	a_i, m/s	n_i
0	0-7 (clay)	50	1000	0.0001	1.33
1	8-35 (fine silt)	150	3000	0.0002	1.10
2	36-74 (coarse silt)	250	5000	0.0005	0.90
3	75-130 (fine sand)	400	8000	0.010	0.80

b. For the other size classes, SSFATE uses

$$P_i = 0, \text{ if } \tau \geq \tau_{ul_i} \quad (18)$$

$$P_i = 1.0, \text{ if } \tau \leq \tau_{\ell\ell_i} \quad (19)$$

where

τ_{ul_i} = the shear stress above which no deposition occurs for grain class i

$\tau_{\ell\ell_i}$ = the shear stress below which the deposition probability for grain class i is 1.0

For values of τ between $\tau_{\ell\ell_i}$ and τ_{ul_i} , linear interpolation is used.

Typical values for $\tau_{\ell\ell}$, and τ_{ul} are given in Table 2.

A typical value for τ_{cd} is 0.016 Pa.

Next, the deposition of sediment from each size class from each bottom cell during the current time-step is computed. The computations start with the largest size class:

Table 2		
Typical values for shear stresses, Pa		
Class	$\tau_{\ell\ell_i}$	τ_{ul_i}
0	0.016	0.03
1	0.03	0.06
2	0.06	0.20
3	0.20	0.90

$$Flux_i = b_i C_i Ws_i P_i \quad (20)$$

where b_i is a probability parameter that includes all other factors influencing deposition other than shear.

This mass is then removed from the particles occupying the cell. The deposition for the remaining size classes is then computed, starting with the second largest size class and working down to the smallest. This deposition is computed as follows:

If $0 \leq P_i \leq 0.05$, then

$$Flux_i = \frac{C_i Flux_{i+1}}{C_{i+1} + 1} \quad (21)$$

otherwise,

$$Flux_i = b_i C_i Ws_i P_i \quad (22)$$

The following are typical values for the coefficient b_i for the four size classes previously presented:

- $b_0 = 0.2$
- $b_1 = 0.4$
- $b_2 = 0.6$
- $b_3 = 1.0$

APPLICATION ASPECTS: The first step in an application of SSFATE is to establish an operational area. Locations can range from rivers, lakes, and estuarine systems on a spatial scale of up to tens of kilometers. For each location, the user supplies digital data describing the shoreline and the bathymetry. These data can be digitized from an appropriate map, obtained from digital databases, or produced using an external GIS and imported into the system. The user may have as many locations in the system as computer storage allows and can rapidly change from one location to another by simply loading the appropriate data set into the application.

The embedded GIS allows the user to input, store, manipulate, analyze, and display geographically referenced information. The GIS has been designed to be user friendly, interactive, and fast. However, it does not have the ability for sophisticated mapping or logical set-based calculations. GIS data may not be required by a particular application, but are often helpful in analyzing and interpreting model predictions.

Additional information about geographically referenced data can be obtained through the use of linking procedures. These link files may include charts, graphics, tables, tutorials, bibliographies, text, photographs, or animations. Examples of data that might be stored in the GIS include physical characteristics of the dredged material, details of the placement site location, current meter data sets, and distribution of potentially impacted biota.

A suite of tools is provided within the SSFATE modeling system to import, export, and manipulate environmental data. As an example, time series of scalar or vector data at single or multiple points can be imported. Spatial data can be imported for rectangular or boundary-fitted gridded regions. Through this procedure, data from external models (e.g., hydrodynamic models) or measuring systems (e.g., moored current meters) can be accessed and used as input to the SSFATE modeling system. Tools are also available to import/export data from/to other GISs and existing databases and to create/delete/edit databases in the embedded GIS.

Input data required include the shoreline (or a boundary-fitted numerical grid), bathymetry, ambient currents (either limited field data to generate painted currents or flow fields imported from a numerical hydrodynamic model), dredged material sediment characteristics, model parameters, and output display parameters. In general, spatial information input to SSFATE is handled through the gridding module of the GIS. Time-series data are addressed with environmental data management tools and model parameter options. Input to specify the sediment characteristics, source strengths and locations, and display options is managed through a set of model-specific input forms. Data input is largely based on graphical techniques since they are accurate and fast.

As noted, either a boundary-fitted grid can be imported or a rectangular land-water grid can be generated by SSFATE. For the case of a rectangular grid, the user can apply the suspended sediment fate model in any subdomain of the location area selected. The user identifies the subdomain of interest through its corner points and selects the appropriate grid size. A gridding algorithm is then used to generate a land-water rectangular grid system.

When the rectangular grid is generated, the user may edit the computer-produced grid to better conform to the shoreline or represent openings to restricted passages (e.g., between islands, narrow inlets, etc.). Editing is also useful to add features that are not given on the base map. Once completed, a bathymetric file is automatically generated and stored under a user-selected grid file name. Multiple grid files can be made to define different areas or the same area with various modifications.

SSFATE requires a flow field for execution of the particle tracking computations. As previously discussed, such a flow field can be generated or painted using limited field data (not a mass conservative field) or can be imported as output from a 3-D numerical hydrodynamic model on a boundary-fitted grid.

Model output includes animation of the particles representing each sediment type individually or all of the particles together. A typical snapshot from an animation of suspended sediment particles being transported away from a dredging site is presented in Figure 3. The output display system is designed so that the user can interact with the display window at any time during the trajectory view operation to obtain information on mass balance for a selected size class of particles. Additional model output includes both horizontal and vertical concentration contours of each sediment type or a superposition of all suspended sediment, time-series of suspended sediment concentrations at a particular point, spatial distribution of sediment deposited on the sea bottom, and tabular summaries of how much sediment is in suspension, how much has been deposited, and how much has left the grid. A contouring procedure is available to provide dredged material thickness distributions on the sea bottom and concentrations at user-defined depths in the water column. The user may select the contour intervals and threshold value. The user can interact with the contoured data to obtain pertinent information such as a cross-sectional view along a user-selected transect, the distance to features from the sediment source, and the area covered by material that has been deposited on the bottom.

CONCLUSIONS: A personal computer based modeling system called SSFATE for computing suspended sediment concentrations resulting from dredging operations has been presented and its major components have been described. SSFATE can be used anywhere in the world and provides an integrated and unified system to support data display, model application, and interpretation of results.

SSFATE has been developed to satisfy a specific need for tools to aid in negotiation of environmental windows. Predetermined attributes of such a tool included adaptability to a broad spectrum of dredging project scenarios, low "front end" requirements for input data or supporting hardware, efficient computational algorithms to enable multiple simulations in a short period of time, and effective means of output visualization. The strengths of SSFATE are in its versatility, simplicity, efficiency, and low cost of operation. In tandem with other tools being developed under the auspices of the DOER Program Environmental Windows Focus Area (e.g., FISHFATE, see Ault, Lindeman,

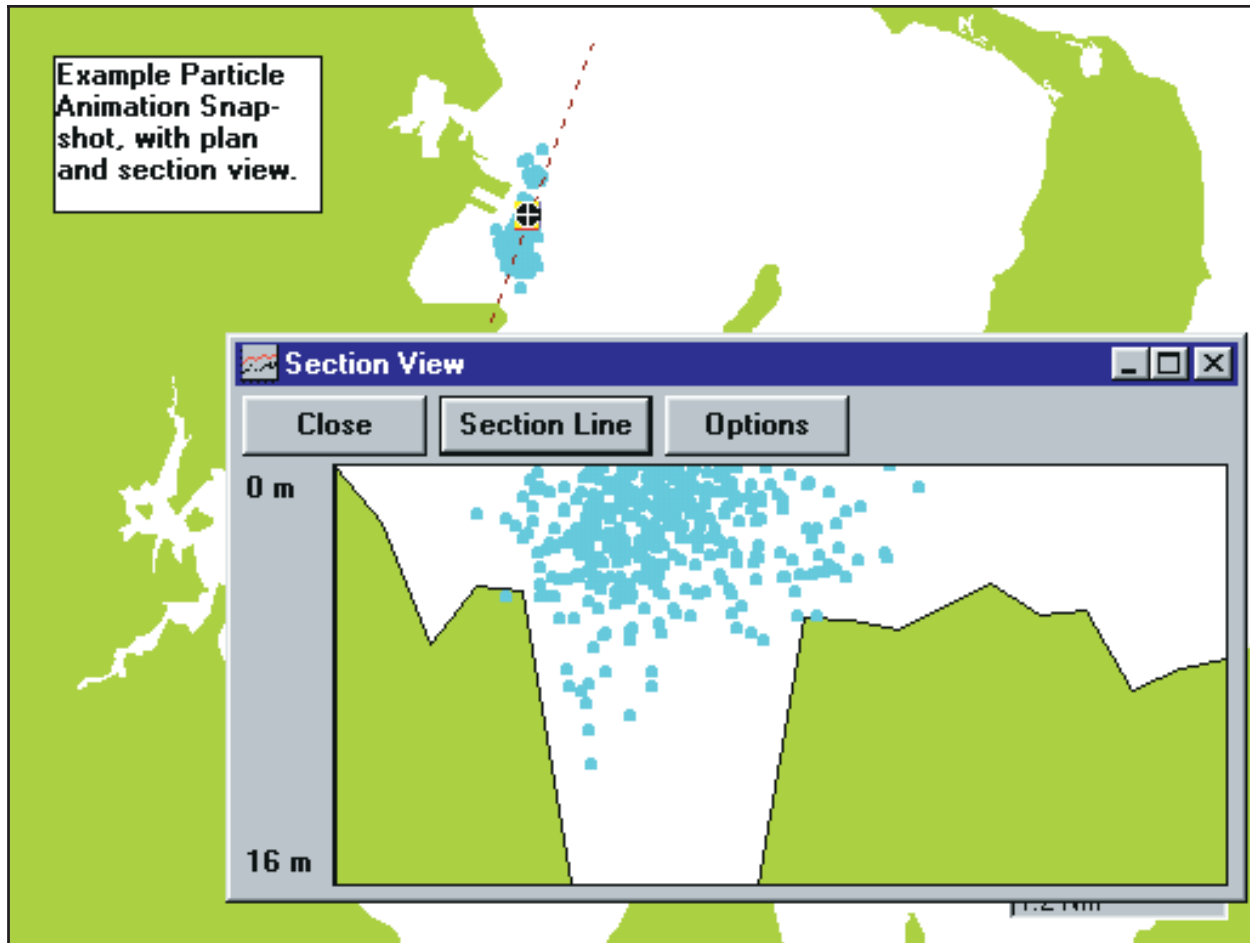

Figure 3. Snapshot from an animation of sediment particles

and Clarke 1998), SSFATE represents a significantly improved capability for dredging project assessments. Dredging project managers and resource agency staff should be able to rapidly explore the effects of model parameters on expectations of impacts, and to optimize their management options, including environmental windows, based on SSFATE results.

POINT OF CONTACT: For additional information, contact Dr. Billy H. Johnson (601-634-3425, johnsob1@wes.army.mil), Mr. Allen M. Teeter (601-634-2820, teetera@wes.army.mil), Dr. Douglas G. Clarke (601-634-3770, clarked@wes.army.mil), or the Program Manager of the Dredging Operations and Environmental Research Program, Dr. Robert M. Engler (601-634-3624, englerr@wes.army.mil). This technical note should be cited as follows:

Johnson, B. H., Andersen, E., Isaji, T., Teeter, A. M., and Clarke, D. G. (2000). "Description of the SSFATE numerical modeling system," *DOER Technical Notes Collection* (ERDC TN-DOER-E10), U.S. Army Engineer Research and Development Center, Vicksburg, MS. www.wes.army.mil/el/dots/doer

REFERENCES

- Ault, J. S., Lindeman, K. C., and Clarke, D. G. (1998). "FISHFATE: Population dynamics models to assess risks of hydraulic entrainment by dredges," DOER Technical Notes Collection (TN DOER-E4), U.S. Army Engineer Research and Development Center, Vicksburg, MS. www.wes.army.mil/el/dots/doer
- Cressman, G. P. (1959). "An operative objective analysis scheme," *Monthly Weather Review* 86, 293-297.
- Johnson, B. H., Kim, K. W., Heath, R. E., Hsieh, B. B., and Butle, H. L. (1991). "Development and verification of a three-dimensional numerical hydrodynamic, salinity, and temperature model of Chesapeake Bay," Technical Report HL-91-7, U.S. Army Engineer Waterways Experiment Station, Vicksburg, MS.
- Johnson, B. H., and Fong, M. T. (1995). "Development and verification of numerical models for predicting the initial fate of dredged material disposed in open water," Technical Report DRP-93-1, U.S. Army Engineer Waterways Experiment Station, Vicksburg, MS.
- Johnson, B. H., and Parchure, T. M. (1999). "Estimating dredging sediment resuspension sources," *DOER Technical Notes Collection* (TN DOER-E6), U.S. Army Engineer Research and Development Center, Vicksburg, MS. www.wes.army.mil/el/dots/doer
- Nakai, O. (1978). "Turbidity generated by dredging projects." *Management of bottom sediments containing toxic substances*, Proceedings of the Third U.S.-Japan Experts' Meeting, Easton, MD, November 1977. EPA-600/3-78-084, S. A. Peterson and K. K. Randolph, ed., Environmental Protection Agency, Office of Research and Development, Corvallis Environmental Research Laboratory, Corvallis, OR, 31-47.
- Reine, K. J., Dickerson, D. D., and Clarke, D. G. (1998). "Environmental windows associated with dredging operations," *DOER Technical Notes Collection* (TN DOER-E2), U.S. Army Engineer Research and Development Center, Vicksburg, MS. www.wes.army.mil/el/dots/doer
- Teeter, A. M. "Cohesive sediment modeling using multiple grain classes; Part I: Settling and deposition" (in review), *Coastal and estuaries fine sediment transport; processes and applications*, papers from INTERCOH 98, South Korea.

NOTE: *The contents of this technical note are not to be used for advertising, publication, or promotional purposes. Citation of trade names does not constitute an official endorsement or approval of the use of such products.*

APPENDIX E

SCOPING DOCUMENTS

E-1* Scoping Report—Liberty Development and Production Plan (MMS, 1998)

E-2* Liberty Information Update Meetings (MMS, 2000)

Scoping Report — Liberty Development and Production Plan (MMS, 1998)

This appendix was published as part of the Liberty Development and Production Plan (DPP) Draft Environmental Impact Statement (EIS) and was not revised for the Final EIS. The reader is referred to this appendix in the Draft EIS. This appendix is also available on the CD-ROM (MMS 2002-019 CD) and on the Internet (<http://www.mms.gov/alaska/cproject/liberty>).

Appendix E-1

Scoping Report—Liberty Development and Production Plan

by Minerals Management Service, June 26, 1998

The scoping report is included in this EIS, because some of the issues that were identified during the scoping process are discussed and evaluated only in this report. Key issues from the scoping report are summarized in Section I of the EIS; however, the scoping report itself contains important information that we feel should be available to people interested in this proposed project. Because scoping is an ongoing process, some scoping issues were identified after this report was completed. These issues are discussed in Section I.E of this EIS.

A. PURPOSE OF THE SCOPING REPORT

This report:

- contains a summary of the responses to the Notice of Intent to Prepare an EIS;
- identifies the significant environmental issues and alternatives that will be evaluated in greater detail in the EIS for the proposed BPXA Plan; and
- identifies other issues and alternatives that will not be evaluated and states the rationale for not doing so.

The National Environmental Policy Act of 1969 requires that an EIS be prepared for any significant Federal project that can be expected to have a significant impact on the environment. An EIS must include:

- any adverse environmental effects that cannot be avoided or mitigated,
- reasonable alternatives to the proposed action,
- the relationship between short-term uses and long-term productivity of the environment, and
- any irreversible and irretrievable commitments of resources.

“Scoping” is the term used to identify the scope and significance of important environmental issues associated with the proposed Plan through the coordination of Federal, State, and local regulators ; the public and interested individuals and organizations prior to the writing of the EIS. During the scoping process, information that may relate to the proposed Plan and any alternatives to the proposal is sought from various sources. This process also identifies and discusses issues that are not “significant” as defined by the National Environmental Policy Act; are not relevant to the Liberty Project; have been covered by previous environmental reviews; or are beyond the scope of the EIS for this Plan.

This Scoping Report discusses a variety of issues and concerns raised in the scoping process. Pipeline design and safety (risk of oil spills), gravel island design, and surface location were some of the major concerns raised.

The scoping process will continue as the draft EIS is prepared. As new issues are identified or clarified, the EIS draft will be modified accordingly.

B. SUMMARY OF THE SCOPING PROCESS

On February 23, 1998, the Minerals Management Service (MMS) initiated the scoping process by publishing a Notice of Intent to Prepare an EIS for the proposed Liberty Plan. We deemed the Plan submitted under 30 CFR 250.34(f) on February 19, 1998. Copies of the plan were distributed to Federal and State agencies, the North Slope Borough, and local communities (Barrow, Nuiqsut, Kaktovik). Copies of the Plan are on file and available from the MMS office in Anchorage, the Noel Wien Library in Fairbanks, and the

Tuzzy Consortium Library in Barrow. Notices on the availability of the Plan for review were distributed to MMS's mailing list of interested parties. Following distribution of the Plan, scoping meetings were held in Anchorage, Barrow, Nuiqsut, Kaktovik, and Fairbanks. The Plan also was discussed on a radio talk show broadcast North Slope-wide on Station KBRW in Barrow.

1. Summary of Written Comments Received in Response to the Notice

The MMS received seven written comments on the proposed Plan. Below are summaries of the comments received from

U.S. Department of Energy
 State of Alaska, Division of Governmental Coordination
 Greenpeace, et al.
 U.S. Department of the Interior, Office of the Secretary,
 Office of Environmental Policy and Compliance
 Alaska Public Campaigns and Media Center
 David von den Berg
 Petersburg Energy LLC

More detailed comments and responses appear in Sections II through V.

a. U.S. Department of Energy

- 1) referred MMS to their comments submitted on the Bureau of Land Management's National Petroleum Reserve-Alaska draft EIS
- 2) re-emphasized that the USDOE supports rational, responsible, and environmentally protective development of domestic energy resources

b. State of Alaska

Division of Governmental Coordination:

- 1) recognized the contribution of the project to the local and State economy
- 2) enclosed scoping comments from various State of Alaska departments

State Pipeline Coordinator's Office:

- 3) requested that the Liberty EIS include the following analyses:
 - a) public access, including across transition and tie-in areas as well as across the onshore pipeline corridor
 - b) subsistence, specifically the impacts on individuals who rely on fish, wildlife, and flora for subsistence purposes
 - c) health and safety concerns, including risks to the public from pipeline operation, maintenance, and abandonment

- 4) did not review the Oil Discharge Prevention and Contingency Plan, as the Department of Environmental Conservation will provide substantive comments

Alaska Department of Fish and Game:

- 5) supports the concept of an offshore drilling and production facility on an artificial island with a subsea pipeline connection with onshore transportation facilities
- 6) prefers offshore structures and subsea pipelines to gravel causeways
- 7) endorses the use of the Kadleroshilik River floodplain site as a gravel source as the extraction of the gravel would provide a deepwater overwintering habitat for fish
- 8) requests that the EIS explore issues relating to human/bear interactions issues that might occur during construction and operation
- 9) requests at least five feet of clearance between ground cover and the bottom of elevated pipelines to minimize effects on migrating caribou
- 10) did not identify any concerns that could not be resolved through the normal consultation and permitting process

Alaska Department of Environmental Conservation, Division of Spill Prevention and Response:

- 11) identified extensive detailed revisions and additions to the Oil Discharge Prevention and Contingency Plan; these comments focused on the following topics/headings:
 - a) Response Action Plan: planning standards, storage tank failure; well blowout; deployment strategies, emergency action checklist; transportation of personnel and equipment to spill site; well control plan; trajectory analysis; and general response procedures for containment, recovery, and protection and clean-up of environmentally sensitive areas and areas of public concern;
 - b) Prevention Plan: overfill prevention for diesel, slop oil, and produced water tanks; description of secondary containment for offshore tanks and facility piping requirements for corrosion control; operating requirements for exploration and production facilities; pipeline surveillance; potential discharge; and operational conditions increasing risk of a discharge; and discharge detection;
 - c) Supplementation Information be provided for oil storage containers; process and flowline description; pipeline details; command system spill response organization; realistic maximum response operation limitation; logistical support; response equipment; nonmechanical response information; response contractor and training program information; and protection of environmentally sensitive areas and areas of concern;
 - d) Best Available Technology on leak detection system for tanks; pipeline leak detection, monitoring, and operations;

- e) Appendix B: Response Scenarios; revise and update.

Alaska Department of Natural Resources, Division of Oil and Gas:

- 12) Included a summary of major issues from State Sale 86 (1997), which included:
- a) Reduced access to once-open range. Impediments to access include facilities and pipelines. Avoid traditional use sites.
 - b) Increased presence of non-Natives and nonresidents near Nuiqsut which may offset the balance between traditional and modern lifestyles of the residents. Developers need to respect ancestral graves and provide education on Inupiat cultural values.
 - c) Aircraft overflights and vehicular traffic may disturb nesting birds and migratory routes of caribou.
 - d) Offshore seismic, drilling, and support craft noise disturb migrating whales; resulting in increased danger and decreased chance of success, for subsistence whalers.
 - e) Technology does not exist to clean up oil spilled under sea ice, or in whiteout or ice fog conditions.
 - f) Project could mean loss of fish and wildlife habitat as well as an increase in air and water pollution.
 - g) Limit access to some barrier islands which are important to whalers and nesting birds.
 - h) Siting of causeways or other structures in rivers' mouths and nearshore waters may adversely affect water quality and fish migration.

Alaska Department of Environmental Conservation, Division of Air and Water Quality:

- 13) Discuss methods to reduce the transport of sediment away from the construction site for both island and trench construction.
- 14) Evaluate real-time leak-detection systems for submerged pipelines and publish a detailed comparison of the threshold sensitivities of various leak-detecting systems.
- 15) Discuss the impact of discharges on water quality.
- 16) Analyze the increase in solid-waste generation and options of disposal at existing facilities and the impact on those facilities.
- 17) Discuss potential impacts on air quality.
- 18) Discuss abandonment procedures and alternatives for the island and the offshore pipeline.
- 19) The office supports the comments received from the Alaska Division of Spill Prevention and Response.

c. Greenpeace et al.

- 1) Discuss all the potential direct, indirect, and cumulative impacts of the Liberty project on the Beaufort Sea region and the Arctic, both onshore and offshore.

- 2) Include comprehensive analysis of how the project will affect climate change in the American Arctic and, conversely, how climate change might affect the project.
- 3) Address traditional knowledge and the project's impact on subsistence species.
- 4) Evaluate spill prevention and contingency plans, including ice gouging, pipeline failure, blowouts, cleanup in various ice conditions, and the toxic impact on wildlife, habitat, and marine flora and fauna.
- 5) Explore alternative sources for renewable energy.

d. U.S. Department of the Interior, Office of the Secretary, Office of Environmental Policy and Compliance

- 1) Disagrees with the statement "implementation of an approved Oil Spill Contingency Plan will effectively limit the potential for adverse impacts to wildlife and habitats as a result of a spill." Agency feels that the discharge prevention and contingency plan does not support the above statement.
- 2) Comments were primarily about the Oil Discharge Prevention and Contingency Plan and requested additions or revisions to selected sections, specifically, that BPXA:
 - a) revise the wildlife protection section of the contingency plan to specify how BPXA plans to fulfill tasks identified in the January 1997 Wildlife Protection Guidelines for Alaska;
 - b) list all categories of environmentally sensitive areas and areas of public concern; ;
 - c) update U. S. Fish & Wildlife contact information;
 - d) adopt a policy for immediate notification of appropriate wildlife resource agencies for wildlife which would be at risk during an oil spil;
 - e) modify their "Oil Spill Response Checklist for Wildlife Hazing" to specify pre-approval from wildlife resource agencies for hazing activities for particular species; including migratory birds;
 - f) revise the Response Checklist for Capture, Stabilization and Transport of Wildlife to include appropriate wildlife resource agencies and Federal and State on-scene coordinators approvals; and recognize that the U.S. Fish and Wildlife Service (FWS) is responsible for decisions concerning euthanasia of migratory birds and polar bears; and
 - g) develop incident-specific plans for the salvage and disposal of dead oiled birds and mammals.

e. Alaska Public Campaigns

- 1) Have concerns about the apparent lack of appropriate pathways to seek consent of the "indigenous peoples" of the Arctic.

- 2) Conduct an impact analysis of the effects of the oil and gas industry infrastructure on the wildlife, fish, and environment of the North Slope. Efforts should be made to incorporate the results of the traditional subsistence survey now under way.
- 3) Conduct more study on ice gouging to develop reliable estimates of potential impacts.
- 4) Undertake an exhaustive survey of the Boulder Patch areas.
- 5) Provide a complete range of alternatives that the public may review. Explore alternatives to offshore drilling and include cost comparisons.

f. David von den Berg

- 1) Wait until Northstar is resolved.
- 2) Need to address cumulative impacts in the Arctic resulting from oil and gas development.
- 3) Provide a full range of alternatives in the EIS.

g. Petersburg Energy LLC

- 1) The Plan fails to meet basic requirements of the Code of Federal Regulations and provides no basis for informed evaluation.
- 2) The Plan is inconsistent with conservation of natural resources and prevention of waste.
- 3) The Plan underestimates the reserves in the Liberty prospect.
- 4) The Plan does not serve the best interests of the public or adjacent private mineral interest owners.

2. Summary of Oral Comments Received at Scoping Meetings

Scoping meetings were held in Nuiqsut (March 18), Barrow (March 19), Anchorage (March 25 and April 8), Kaktovik (March 31), and Fairbanks (April 1). Staff from MMS and representatives from BPXA attended these meetings, provided an overview of the project, answered questions about the proposed Liberty project and the ongoing process and schedule, listened to and noted the concerns voiced about the proposed project. Oral comments were received from 82 individuals who attended at least one of the scoping meetings. A summary of these comments follow. Some traditional knowledge appears in Section II.H. of this report. The list of attendees at the scoping meetings is included at the end of this chapter.

a. Nuiqsut Meeting, March 18, 1998

(1) Island Construction

- 1) Gravel bags pose a problem to navigation and, even if they sink to the bottom, they may be dangerous to the environment, particularly bowheads,
- 2) Questions were raised as to why the Liberty production facility was not designed like Northstar, and whether the project design as presented was final or preliminary.
- 3) Expression of concern with regard to the ice override, and whether the island, as designed, could withstand the force of the moving ice.
- 4) Concerns that the island berm could not contain a large oil spill.
- 5) Statements were made regarding the need for more subsistence studies in the Beaufort Sea as well as concern that the scientists and consultants were only using "Western" science and not relying heavily enough on the traditional knowledge of the people who live there.

(2) Pipeline Design

- 1) Concerns that the pipeline construction would disrupt fish habitats.
- 2) Questions as to how BPXA would detect oil spills.
- 3) Concerns that the heat from the pipeline will affect the permafrost layer, and the lack of technical information that has been made available on this subject.
- 4) Questions as to the depth the depth that the pipeline will be buried.

(3) Ice Override, Wave & Oil Spill Concerns

- 1) Ice override was an important issue that cannot be overlooked and there were concerns that the island could not withstand the force of the ice.
- 2) Concerns about the island's ability to withstand the wave forces in its present location.
- 3) Oil Spills:
 - a) Questions as to whether BPXA could prevent and/or clean up an oil spill.
 - b) Concerns about the lack of a proven method to clean up spilled oil in the Beaufort Sea and restore the environment.

(4) Impact Assistance

- 1) The local residents aren't getting their share of 8(g) monies from the State.
- 2) The MMS is not doing a good job lobbying Congress for impact assistance.

(5) Island Access

- 1) Subsistence hunters must be allowed to land on the Liberty Island in the case of an emergency and should not be treated like criminals as they have been at other offshore oil and gas gravel pads.
- 2) Suggestions that BPXA should consider having a local Native Corporation provide security for the island.

(6) Public Process

- 1) More time to comment on the draft DPP is needed.

b. Barrow Meeting, March 19, 1998
(1) Island Construction

- 1) Questions as to what plans there are to use the gravel from Tern Island to construct Liberty as well as any intention to use Tern Island as a drill site.
- 2) Recommendations that BPXA directionally drill the Liberty project from onshore. If directional drilling from onshore was not technically feasible, then the island should be constructed as close to shore as possible – though a depth of 15 to 20 feet of water would be better.

(2) Pipeline Design

- 1) North Slope residents are opposed to the project, because the offshore pipeline could threaten their environment and way of life.
- 2) Concerns that the back fill areas will be more prone to damage from ice and wave activity.
- 3) Concerns about the effects of ice scour and movement of the ice sheets against the island.
- 4) Concerns about the burial depth of the pipeline with many residents stating that seven to nine feet deep was not adequate.

(3) Subsistence Activities

- 1) Concerns that noise levels will cause the whales to alter their migration path.
- 2) Concerns that the proposed island is located in an important whale feeding area.
- 3) Expressions that the NSB needs funding to conduct the subsistence studies required to provide information about the impacts of the project.
- 4) Concerns about the leaching of chemicals or oil from cement blocks and emissions from industrial stacks which leave a sheen on and disburse scents into the water, a change in the character of the water which Bowhead sense. This may cause them to alter their migration route.
- 5) Concerns that any change in the whale migration route can affect subsistence hunting.
- 6) Statements from some residents to the effect that the NSB opposes offshore oil and gas development, because the industry cannot guarantee subsistence and whaling activities will not be affected.

(4) Oil Spills

- 1) Questioned whether BPXA will have to demonstrate to MMS that it can clean up oil in broken ice.
- 2) Expressions of concerns that the EIS should acknowledge oil spills in the Arctic must be cleaned up.

(5) Impact Assistance

- 1) Statements to the effect that local communities should receive more of the economic benefits if the project goes forward since sharing is an important part of the Inupiat culture.

(6) Island Access

- 1) A suggestion was made to establish a marine radio repeater station on Liberty island.
- 2) Statements were made that if the project goes forward, hunters who have to stop on the island should be treated with respect and not like criminals.

(7) Economic Effects

- 1) Questions were raised as to what kind of economic return the local residents and village corporations would receive if the project goes forward.
- 2) Statements were made regarding how the village corporations should be involved in the planning, construction, and development of the project.
- 3) Recommendations for long-term training for local residents were voiced.

(8) Scouring and Ice Data

- 1) Concerns that ice-scour data was adequate.

(9) Other Issues

- 1) Questions as to other criteria BPXA was considering besides oil spills when it was evaluating potential problems with Liberty.
- 2) Questions as to what monitoring for air quality would be required.
- 3) Statements that there would be a need for an icebreaker in case of a blowout.
- 4) Statements that the Beaufort Sea should be the last place the oil industry should explore for oil.

(10) Alternatives

- 1) Several residents stated that something should be constructed at Point Brower to support the Liberty project from onshore.
- 2) It was recommended that Liberty island be in water no deeper than 6 feet to allow bowheads to maintain their traditional migration patterns.

c. Kaktovik Meeting, March 31, 1998
(1) Project Description and Environmental Report

- 1) There was concern that Kaktovik was being neglected when it came to discussions of the effect of the project on Arctic communities.
- 2) Concerns about the displacement of bearded seals (ugruk) from the area when construction begins. The seals are an important food source to the village because each family needs 5 gallons of seal oil per family per year.

- 3) The need to discuss the impact of the development on beluga whales was voiced.

(2) Pipeline Design

- 1) There were concerns as to the ability of the oil company to shut down the pipeline quickly in case of a rupture
- 2) There was discussion and concern as to the impact of the project on the permafrost along the pipeline route.
- 3) Concerns were raised as to the impact on Boulder Patch communities.
- 4) Concerns were raised about the silt being deposited around Tigvarik Island.
- 5) Concerns about the island depth, pipeline depth, trenching, and the onshore portion of the pipeline.
- 6) Questions were also raised regarding Native allotments where the pipeline comes ashore.

(3) Subsistence Activities/Whaling

- 1) Concerns about the effectiveness of the Oil/Whalers Agreement.
- 2) Concerns about the effect of noise on bearded seals.

(4) Oil Spills

- 1) Many resident of North Slope communities are uncomfortable with offshore drilling because they feel there is no way to handle spills.

(5) Impact Assistance

- 1) Concerns about the lack of impact assistance.

(6) Alternatives

- 1) Expression of confusion about what the alternatives to the project were.

(7) Public Process

- 1) Kaktovik would like to be involved in the major milestones of the project.

d. Anchorage Meeting, March 25, 1998

(1) Pipeline Design

- 1) Concerns over the design of the proposed route.
- 2) Concerns about future development and the effects of additional pipelines.
- 3) Concerns about impacts on climate change on the subsea pipeline

(2) Liberty Plan Project Description

- 1) Expression of concern that discharge sources were not included and several individuals asked when the National Pollution Discharge Elimination System (NPDES) permit application would be filed.
- 2) Concerns that there were no baseline or site-specific studies of flora and fauna at either the gravel site or the island site.

(3) Oil Spills

- 1) Concerns that there was no mention of a catastrophic oil spill and the feeling that the oil spill plan as presented by BPXA was just wishful thinking.
- 2) Concerns over the quality of spill/leak detection systems.
- 3) Concerns that the NEPA review was being done independently of the response planning.

(4) Global Warming/Arctic Climate Change

- 1) It was asked if BPXA evaluated the impacts of Arctic climate change on the pipeline and the impact of oil production from Liberty on the climate.
- 2) Several public members stated that MMS should support and study renewable energy sources.

(5) Public Process

- 1) Expressions of concern about the validity of the NEPA process.
- 2) Expressions of concern about the short notice for the meetings.
- 3) Statements that it was difficult for the public to identify cumulative effects of project such as Liberty and others which may be online.
- 4) Concerns that there needed to be an open public process on pipeline engineering.
- 5) There needs to be more publicity about the meetings.

(6) Reservoir Management/Boundaries

- 1) The reservoir is poorly defined.

(7) Cumulative Effects

- 1) Concerns about the development of satellite facilities extending out from Liberty.

(8) Biological/Environmental Concerns

- 1) Concerns about the lack of baseline studies for bird migration, fish population and polar bears dispersal data.
- 2) Concerns about oil spills, sedimentation, and damage to Boulder Patch communities.
- 3) Concerns as to a comprehensive index of what data was available.

e. Anchorage Meeting, April 8, 1998

(1) Pipeline Design

- 1) Concerns about monitoring the pipeline construction.
- 2) Concerns about pipeline burial depth and the effects of ice gouging on pipeline safety.
- 3) Concerns about a breach under the pipeline and the effects of permafrost.
- 4) Concerns about the effects of climate change on the pipeline including melting permafrost, melting sea ice, and sea level changes.

- 5) Concerns about the shoreline crossing and how it was selected.

(2) Liberty Plan Project Description

- 1) Concerns about the abandonment procedures after the field is depleted.
- 2) Concerns about natural gas in the area, blowouts, transportation impacts, and field depletion.
- 3) Interest was expressed in the feasibility of directional drilling from onshore locations.

(3) Oil Spills

- 1) Concerns about the industry's track record for oil cleanup and there were some requests that cleanup equipment be onsite to handle more than one spill at a time.
- 2) At least one person stated that the contingency plan was inadequate.
- 3) It was stated there was a need for more field work and less reliance on computer models.

(4) Global Warming/Arctic Climate Change

- 1) Concerned about real numbers for greenhouse gas projections. Must quantify the effect of burning 120 million barrels of oil.
- 2) Concerned about the impacts of Arctic climate change.

(5) Public Process

- 1) Needs to address alternative energy sources.
- 2) Needs to provide more lead time for meetings.
- 3) Delay the Liberty EIS until Northstar is completed so the public has the benefit of that information.

(6) Cumulative Effects

- 1) Must consider cumulative effects from all projects on the North Slope.
- 2) There was an expression of concern over radioactive materials.
- 3) Concerns were expressed over long-term air pollution impacts.

(7) Traditional Knowledge

- 1) There were suggestions that MMS should make certain to incorporate traditional knowledge into the document.
- 2) There were expressions of concern that local indigenous people were not being adequately represented in the EIS.

f. Fairbanks Meeting, April 1, 1998

(1) Island Construction

- 1) There was concern about the proposed number of helicopter overflights expected during construction, the size of the expected workforce, and other construction activity especially during the periods when birds are molting and cannot fly away.

- 2) There was a suggestion to use Tern Island for development instead of building another island.

(2) Pipeline Design

- 1) Concerns about the effects of heat on the permafrost.
- 2) It was suggested that the EIS clarify technical design features and rationale so the public can determine if it is worth the risk.

(3) Biological Concerns

- 1) Concerns about the impacts to marine mammals and birds.
- 2) Concerns about disturbances to biological populations, in spite of small footprint.
- 3) Concerns about the many unsubstantiated statements of effects in the Environmental Report.
- 4) Concerns about the increased number of predators (foxes and gulls specifically) in the area lured by artificial food sources on the island.

(4) Public Process

- 1) There was an expression of need for MMS to improve wording on newspaper ads.
- 2) Concerns about the Liberty project in relation to Northstar and the suggestion that the Liberty Project be put on hold for the moment.
- 3) What is the difference between a scoping meeting and public meeting?
- 4) Concerned that MMS look at the science and not just pull material from previous EIS's.

(5) Cumulative Effects

- 1) The MMS should consider this project in light of other projects that will follow and address all the potential cumulative effects.

C. ENVIRONMENTAL ISSUES ANALYZED IN THE EIS

The following environmental, socioeconomic, technical, or design issues are identified for analysis in this EIS, because they are related to important resources, activities, systems, or programs that could be affected by petroleum development and production and the transportation associated with production.

The EIS also will analyze the cumulative effects of the proposed Liberty Plan and other present and anticipated major activities.

1. Offshore Platform and Pipeline Oil Spills

The impacts of a potential oil spill from this proposed project on the various resources will be evaluated in this EIS. The EIS will:

- address the impacts of an oil spill from a blowout or from a pipeline leak;
- include an independent oil-spill-risk analysis and several different receiving environments based on differing seasons, weather and ice conditions, including a very large but unlikely oil spill event;
- analyze the fate and effects of an oil spill in open water, solid ice, and broken ice; and
- explain the differences between BPXA's estimated oil spill sizes in the project description and the sizes MMS uses in our oil spill risk analysis.

2. Oil Spill Response Capabilities and Contingency Planning

As part of its development and production plan, BPXA is required to have an Oil Spill Contingency Plan (OSCP). No development and production operations may be started until an OSCP has been approved. Under MMS's regulatory requirements (30 CFR 250.34), the applicant must demonstrate response capability before project construction begins. This process includes review and approval of the Oil Spill Contingency Plan/Oil Discharge Prevention & Contingency Plan (OSCP/ODPCP) and the North Slope Spill Response Project Team (NSSRPT) Planning process. The Liberty OSCP includes the essential elements required by MMS regulations. The information on response equipment, strategies, trajectory models and other information is consistent with response plans that have been approved for offshore exploratory drilling programs in the Beaufort Sea, with additional information, as appropriate, for long-term development and the subsea pipeline. The State of Alaska, Department of Environmental Conservation, has oil spill planning standards that will apply to the Liberty Development Project through the Alaska Coastal Zone Management Program enforceable policies, and the State portion of the Liberty pipeline right-of-way. The effectiveness of the OSCP will be evaluated during the regulatory and coastal zone management review processes, which occur concurrently with the EIS. The OSCP be distributed with the draft EIS. The EIS will describe BPXA's oil spill response capabilities and contingency planning under Arctic conditions, and analyzes the effects of possible oil spills into the environment, but it doesn't judge the effectiveness of the OSCP to clean up or lessen the oil spill's effects.

3. Pipeline Design

Many individuals expressed concern about risk to the environment from pipeline failure. BPXA's proposed pipeline design incorporates measures the company believes will mitigate these concerns. For example, the pipeline will be buried at a depth that BPXA feels optimizes protection against strudel scours and ice keels. The MMS and the State of Alaska Pipeline Coordinator's Office (SPCO) are evaluating BPXA's proposed pipeline as part of the right-of-way leasing process. The trench and burial depth are among the many factors that will be considered. If the agencies determine that additional measures are required for environmental protection or design integrity, the design must be modified. The EIS will contain an analysis of pipeline design issues. In addition, an alternative to BPXA's pipeline proposal has been developed by MMS, in conjunction with the SPCO. This alternative is being prepared should the technical review determine a depth greater than BPXA's proposed 7-9 foot depth is needed to ensure the safety and integrity of the pipeline. Alternative VI will analyze burying the pipeline deeper, and includes an evaluation of the pipeline trench and burial depth to a maximum of 15 feet (see Section IV.F. of this scoping report.)

4. Island Design and Location

The EIS will analyze the proposed production facility design and location. BPXA proposes to construct a single manmade gravel island. The Liberty gravel island will be reviewed under the MMS's platform verification program. Through this program, all aspects of the island design and construction will be reviewed by an independent engineering firm certified by the MMS. The review will include the following:

- Design criteria examining ice loads; wave, current, and storm conditions; working surface elevation; facility setback; and soil conditions and foundation stability.
- Construction materials including gravel type, density, and size distribution; slope armor/defense materials.
- Performance with regard to the movement, compaction and settlement, ice ride up and override.
- Construction and verification that as-built meets design specifications.

Alternatives to BPXA's proposal have been developed by MMS and will be analyzed as Alternatives III (Southern Island Location and Eastern Pipeline Route) and IV (Use Steel Sheetpile to Protect the Upper Slope of the Island) in the EIS (see Sections IV.C. and D. of this report).

5. Habitat Disturbance and Alteration and Effects on Key Species

The effects of oil spills, discharges, noise from industrial activities, and increases of human interactions with key species and habitat have been identified as important concerns of this project. The EIS will analyze the potential impacts of the proposed development and production operations on:

- the Boulder Patch, including proposed pipeline construction (trenching and backfilling)
- birds; especially to the oldsquaw ducks, from helicopter flights during their nesting and molting periods; and potential risks to nesting birds by predators from increased activities;
- polar bears, particularly denning bears, (there is concern about the sufficiency of baseline information on polar bears);
- marine mammals; including, bowhead and beluga whales; ringed, spotted and bearded seals; and walrus;
- caribou, and other terrestrial species; and
- fish, including proposed pipeline construction (trenching and backfilling).
- known archaeological sites in the area onshore, and the impacts of silt from island construction to the area near Tigvarik Island.

6. Discharges into Water

The impacts and risks from an oil spill to the shoreline that would be at risk; the widespread effects that oil may have from a spill in broken ice that drifts a considerable distance before the oil can be extracted; and the toxic impact of oil on subtidal organisms and all potentially impacted species will be evaluated.

7. Cumulative Effects on Biological and Physical Resources & Social Systems

A major concern of many individuals was the cumulative impact of oil-development activity, including pipelines, on the habitat and key species (particularly the impact on bowhead whales) in the Beaufort Sea. The EIS will:

- evaluate the cumulative effects of the Plan on the resources and people of the North Slope;
- identify the cumulative impacts of the Plan with the other existing and potential new activities, including other potential Outer Continental Shelf (OCS) developments and proposed projects on BLM- and State-managed lands.

8. Protection of Inupiat Culture and Way of Life

Many scoping comments included suggestions that MMS incorporate traditional knowledge into the EIS. The MMS will continue to include traditional knowledge as a key element in our EIS analysis, as has been done for OCS Lease 144 and 170 EISs. The following specific comments based on traditional knowledge were received:

- A Nuiqsut Elder stated that waves at Liberty were usually bigger and more ferocious than those at Northstar, though the ice is not as bad (Sarah Kunaknana).
- Another Nuiqsut Elder commented that he had seen ice in the area pileup more than 20 feet high at Bullen Point. When there is a south wind and incoming tide, the ice can pile up and overrun any facilities on the island (Thomas Napageak).
- In the late 1970's, there were three years of very heavy ice buildup in the area (Thomas Napageak).
- An Elder indicated that, within the Liberty area, ice had piled up and killed her brother when they were living at Cross Island. The changing character of the wind in that area had also caused three hunters to be pushed under the ice. Although they survived the dunking, they froze while walking home (1935). In a separate incident, the elder also related that other hunters have become stuck on the moving ice, and could not get off the ice floe until they were well past Flaxman Island (Sarah Kunaknana).
- Ugruk (bearded seal) is Kaktovik's most highly prized delicacy. There used to be many Ugruk in the area but today there are not enough for the village. Twenty-five gallons of seal oil come from each bearded seal; 5 gallons are needed by each Native family each year. There are 60 families in Kaktovik and we did not get enough bearded seal to allow each family a full supply. There are concerns that the Oil/Whalers Agreement should be expanded to cover all marine mammals, not just bowheads. Bearded seals have been affected by industrial noise and boat traffic. When out subsistence hunting, we have seen the mile-long seismic tow lines during the fall (Fenton Rexford).
- Bearded seals come from the west and they can be seen during the summer after the ice breaks up. It would be interesting to see, through monitoring studies, if bearded seals are diverted as a result of boat traffic, noise, or other drilling activity (Fenton Rexford).

9. Effects of Petroleum-Development Activities on Subsistence Harvests

Another scoping concern is the impact on subsistence hunting and gathering activities on the North Slope. The EIS will analyze the effects of noise generated by the

proposed activities to the feeding and migration routes of marine mammals, especially bowhead whale. Subsistence hunters are concerned that industrial noise will cause the whale migration to move further away from shore, which will increase the risk to hunters and increase the amount of spoilage whale meat. In response to the concern regarding noise disturbance to whales and the commenter's recommended alternative to move the proposed gravel island into shallower waters or to directionally drill from onshore, the EIS also will analyze the effects of an alternative location for the island (see Sec. IV.C, Southern Island Location and Eastern Pipeline Route for a detailed discussion on the site alternative).

During scoping, comments were made as to the importance Liberty Island location to subsistence activities. The MMS will evaluate the potential effects of the proposed project to these activities. One individual asked if the potential air emissions from the stacks associated with onshore construction processes would affect whale feeding and migration. Others expressed concern about the onshore pipelines and how they might impede access to traditional subsistence sites and which sites will be analyzed. Others were concerned that caribou and moose populations are already declining and additional air and water pollution could threaten them further. These concerns all will be analyzed in the EIS.

10. Sociocultural and Economic Impacts to Villages and Native Communities

The EIS will:

- evaluate the potential effects to sociocultural systems and the economy of local communities from the proposed development, including the effects on population growth;
- evaluate the increase of non-Natives in the communities and how that might affect the balance between the traditional and modern lifestyles of the Inupiat people;
- identify the seasonality and size of the workforce that will be created by the project and the potential economic effects to the community;
- identify solid-waste storage disposal sites; and
- evaluate the methods for handling solid wastes and their effects on local communities.

11. Gravel Bags

Many scoping comments were concerned about the use of the proposed gravel bags in the island design. Comments were made that, in the past, gravel bags presented problems to navigation. Because these bags are heavier than bags previously used, they will sink if they enter the water column. Once on the bottom, they may affect benthic

organisms and species that feed on these organisms. In the EIS, the MMS will evaluate slope protection design, including the effects of the use of gravel bags. MMS will also examine an alternative which will analyze an alternative slope design that uses a vertical steel sheet pile wall instead of gravel bags (see Section IV.D., Alternative IV (Use Steel Sheetpile to Protect the Upper Slope of the Island) which describes this alternative).

12. Island Access

During scoping, subsistence hunters voiced concerns about island access. Will subsistence whalers be accepted, or turned away, if they land on the island? In the past subsistence whalers felt that the industrial employees at other sites had not shown respect to the local subsistence hunters. Residents feel they should not be treated like criminals if they stop at the island because they need water or they must seek shelter from a storm. If the project goes forward, they should be treated with respect. The EIS will evaluate this potential impact.

13. Air Quality

The EIS will evaluate the impacts to air quality from the proposed construction activities for the island facility and the pipeline, plus long-term development and production impacts. During scoping, someone asked whether flaring of gas would be evaluated in the EIS. As proposed, flaring at the Liberty facility will be intermittent. The flaring emissions will be evaluated for impacts in the EIS and during the USEPA's review and permitting processes.

14. Water Quality

The EIS will evaluate the effect on water quality from the project. This will include the impacts of the marine water discharges for construction of the island and pipeline, the seawater treatment plant, and the domestic wastewater treatment plant. BPXA plans no discharge of drilling muds and cuttings. Instead, drilling wastes will be stored, if needed, then ground and reinjected into a permitted disposal well.

15. Facilities Abandonment

During scoping, a question was raised as to MMS's abandonment procedures, and whether everything installed for the field would be removed. The EIS will evaluate the potential effects of abandonment of the production facility at the end of the project life. Exact abandonment

procedures will be developed prior to the end of the project life. Based on the existing environmental conditions and environmental regulations enforced at that time, it is anticipated that all equipment, slope protection, and buildings will be removed from the island at abandonment. The pipeline riser and well casings will be removed below the mud line. Pipeline removal will be evaluated prior to the time of abandonment. The Corps of Engineers and other agencies treat abandonment as a permit modification subject to full public review.

16. Other Agency Regulatory Permits and Requirements

During scoping, some comments suggested MMS identify the other agency regulatory and permitting requirements. Sections XI.B. and C. of the Liberty EIS will identify these statutory, regulatory and permit requirements.

D. ISSUES ADDRESSED IN THIS SCOPING REPORT BUT NOT ELSEWHERE IN THE EIS

A number of other issues were raised during scoping. On examination, MMS determined that they warranted a detailed explanation in the Scoping Report but would not be evaluated elsewhere in the EIS, in accordance with CEQ guidelines (40 CFR 1501.7(3)), since they are not expected to have a significant effect on the environment. In determining significance, MMS considered CEQ criteria under Section 1508.27, which defines “significant” by consideration of such factors as affected species being rare and endangered, unique characteristics of the geographical area, level of public controversy and concern, degree of likely impact, and uncertain risks.

These issues/concerns are identified and discussed below. These are presented as bolded questions. The analysis and rationale for why these questions and issues are not analyzed elsewhere in the EIS is contained in the adjoining text below.

1. Monitoring Studies

.....

Will the NSB be involved in the design of monitoring studies? Can the NSB suggest modification?

Monitoring studies are usually suggested and designed at the conclusion of the EIS process. The MMS is committed to working with the State, NSB, and affected communities and will seek their involvement in the design of monitoring studies. No project-specific monitoring has been proposed

at this time. After the completion of the EIS, results of coordination with the NSB and subsistence communities (as required by Sale 144 Lease Stipulation No. 5, Subsistence Whaling and Other Subsistence Activities), the Section 7 consultation process, and other permit reviews (NPDES, PSD, Corps Section 10 of the Rivers and Harbors Act), Section 404 (Clean Water Act), and Section 103 (Marine Protection, Research, and Sanctuary Act)) and Letter of Authorization/Incidental Harassment Authorization authorities, any number of project-specific monitoring programs could be identified. The MMS would involve the NSB in reviewing and commenting on any proposed monitoring programs within MMS’s jurisdiction.

.....

Will MMS monitor the bearded seal to see if it is impacted by noises from drilling and boat traffic?

Effects on the bearded seal from the proposed Liberty Plan will be analyzed in the EIS. This is one of the species on the NMFS marine mammal protection list, and they can require monitoring as part of their Letter of Authorization as required under the Marine Mammal Protection Act for the project; such a monitoring study could analyze the effects of noise on the species. The MMS will coordinate and cooperate with NMFS, but MMS will not implement a requirement for monitoring unless NMFS requires it.

.....

Will there be an air quality monitoring program?

No air quality monitoring is currently proposed. Information on existing air quality is included in the USEPA Prevention of Significant Deterioration (PSD) permit application and used in modeling the incremental increases in selected emissions resulting from proposed Liberty plan activities. Some emission-related monitoring typically is required under USEPA permits, such as visual inspection of plume opacity; however, the final determination is left up to the permitting agency at the conclusion of the PSD permit review process.

2. Conflict Resolution/Agreements

.....

Is MMS considering expanding the Oil/Whalers Agreement to include other marine mammals and not just bowheads?

The Sale 144 Lease Stipulation 5, Subsistence Whaling and Other/Subsistence Activities, requires lessees to minimize potential conflicts with subsistence whaling activities through consultation prior to conducting proposed activities. This stipulation requires that “...the lessee shall consult with the potentially affected subsistence communities, Barrow, Kaktovik, or Nuiqsut, the North Slope Borough (NSB), and the Alaska Eskimo Whaling Commission (AEWC) to discuss potential conflicts with the siting,

timing, and methods of proposed operations and safeguards or mitigating measures which could be implemented by the operator to prevent unreasonable conflicts..." This includes all subsistence activities, not just those associated with bowhead whales.

What is the effectiveness of the Oil/Whalers Agreement?

The stipulation in the previous response also applies here. In response to a similar MMS stipulation and the Letter of Agreement between the oil industry and the National Marine Fisheries Service (NMFS), oil-industry operators signed an Open Water Conflict Avoidance Agreement (July 29, 1997) with the AEW and the Whaling Captains' Associations for Barrow, Kaktovik, and Nuiqsut. This type of agreement (negotiated annually) has been successful in defining appropriate working guidelines and communications procedures for implementation during fall migrations of bowhead whales. The proposed Plan acknowledges that coordination with subsistence communities is ongoing and will continue through the life of the project. We anticipate this type of interaction will continue and will help to mitigate potential conflicts.

BPXA has successfully negotiated two Conflict Avoidance Agreements with AEW and whaling captains to address the effects of the 1996 and the 1997 summer ocean bottom cable seismic exploration programs. Successful negotiation of these agreements was a condition required before NMFS would issue an Incidental Harassment Authorization for the seismic programs. Such coordination will continue throughout the design and planning stages of the project. BPXA will be required to submit updated documentation related to coordination efforts with subsistence communities. The communities will have the opportunity to review and comment on this documentation. No development activities will be allowed until the coordination efforts required under the Conflict Avoidance Mechanisms Stipulation have been completed. Based on consultation with NMFS, BPXA plans to secure an IHA to cover construction activities, and to propose rule making to allow issuance of Letters of Authorization to cover drilling and production operations.

3. In Situ Burning

What are the effects of in situ burning on the environment?

The effects of burning oil in situ were evaluated in the Beaufort Sea Lease Sale 144 EIS (MMS 96-0012), effects on air quality (IV-M-9). As indicated in the EIS, in situ burning is a preferred technique for cleanup and disposal of spilled oil in oil spill contingency plans. Burning could affect air quality in two ways. Burning would reduce

emissions of gaseous hydrocarbons by 99.98 percent and slightly increase emissions of other pollutants. However, incomplete combustion of oil would inject about 10 percent of burned crude oil as oily soot, plus minor quantities of other pollutants in the air. The Regional Response Team has guidelines to evaluate in-situ burn options which would be followed prior to any in-situ burn approval.

4. Climate Change and Alternative Energy Sources

Will MMS evaluate the greenhouse gases for the project, including the eventual combustion of 120 million barrels of oil projected to be produced over the lifetime of the project? Will MMS consider alternative energy sources in the EIS?

Scoping comments under the categories of Global Warming and Alternative Energy Sources were addressed in the MMS Outer Continental Shelf Oil and Gas Leasing Program: 1997-2002 Final EIS on pages IV-63-68 and IV-482-489, respectively. In addition, the Council on Environmental Quality, in its *Draft Guidance Regarding Consideration of Global Climate Change in Environmental Documents Prepared Pursuant to the National Environmental Policy Act*, October 8, 1997, recommends addressing this issue at the program level rather than at the project level.

Have the impacts of climate change (melting permafrost, sea level rise, ice conditions; or increase in the amount and severity of storms) on the project been considered?

The effects of climate change are more appropriately considered in NEPA documents at the program stage, not for individual projects (see OCS Oil & Gas Leasing Program 1997 to 2002 Final Environmental Impact Statement (August 1996) which is incorporated by reference). The life of this project is relatively short and the effects of major climate warming remain relatively long term. Changes to the Arctic environment are expected to be within the range of the current data over the life of the project, and regular monitoring and maintenance of the pipeline and island will ensure adequate corrective action is taken to maintain their integrity. If an immediate threat is encountered, the flow in the pipeline can be stopped, and the wells and the facility can be shut down and if necessary the island can be vacated.

5. Increased Federal Revenue Sharing

Will the Federal Government provide impact assistance to local communities?

Congress, not the MMS, is responsible for the allocation and commitment of Federal funds and, therefore, it will not be analyzed in the EIS. Although MMS hears and understands the concerns and positions stated by the communities, MMS is not authorized to provide the relief requested. Concerns about impact assistance have been passed to MMS management in Washington, D.C., but the ultimate resolution will occur outside of the EIS process. The State of Alaska will receive 27.5% of the revenues from this project and other Federal OCS leases in the 8(g) area (from 3-6 miles offshore) and these funds will become part of the State of Alaska's revenue stream from which the local communities will benefit.

6. Other Comments Not Related to the EIS

BPXA representatives attended all of the scoping meetings and provided an overview of the proposed Plan. Numerous questions at the scoping meetings were directed towards BPXA, which they answered. Some of these questions and concerns follow:

- Is the gas sweet or sour?
- Can a radio repeater be installed on the island?
- Will there be long-term training programs for locals?
- What other incidents, besides oil spills, did BPXA consider when they designed Liberty?
- Is the deep, 20-foot channel designed to move water away from or towards the shore?
- Will there be opportunities for NSB residents to learn more about the project?
- Describe the wave model used to test the island.
- Spend money protecting subsistence resources, not on additional western studies.
- What is the slope of the seabed?

Questions and comments that were not related to the environmental analysis for a Development and Production Plan are not included in this scoping report; they will not be included in the main body of the EIS. An example of such a comment is: "MMS should analyze the effects of radioactive material and pollution."

Various administrative comments and concerns were raised and passed along to the appropriate MMS managers for action. One such concern was that the meetings were scheduled only during the day which prevented some people from attending. In response to this concern, an additional evening in Anchorage was scheduled. Although such concerns are not directly related to an EIS issue, MMS

acknowledges their receipt and has passed them on to the appropriate MMS manager. Also, MMS notes concerns voiced by the public about other projects and MMS-related issues, but these comments are not included in this scoping report as they are not related to the Liberty EIS. Some comments criticized the public notification process MMS used for announcing the scoping meetings and the information provided in those notifications. Although these processes meet the legal requirements, MMS is always interested in feedback from the public and will strive to improve how it interfaces with the public and the quality of the information we provide.

Will village corporations be involved in the planning, construction, and development of the project?

BPXA commitments for local community involvement during the project were noted in the DPP. In addition to conducting meetings in local communities to provide updated information on the project and discuss issues of concern, BPXA will organize a program to incorporate traditional knowledge of village elders into project planning; will negotiate conflict avoidance agreements through the AEW and Whaling Captains Associations of Nuiqsut and Kaktovik for any required monitoring of construction and development activities for potential marine mammal and wildlife impacts; involve community residents and local institutions and organizations in oil spill prevention and response, and in development and implementation of a training program in cultural and environmental awareness for BPXA and contractor employees involved in Liberty development and subsequent production. Specifically, BPXA has developed its Itqanaiyagvik job recruitment and training program intended to train more North Slope residents for jobs in producing fields. This program is a joint venture with Arctic Slope Regional Corporation and its oilfield subsidiaries.

What is the relationship and timing between the proposed Liberty project and the Northstar project?

The cumulative analysis of both documents will analyze the combined effects of both projects. However, each project is unique and must meet the economic constraints and environmental concerns on their own merits. Although BPXA is the applicant on both projects, it is possible that either or both of the projects could be denied, restructured, or delayed. The uncertainty surrounding the timing and distribution of the environmental documents associated with the Northstar project was a factor in MMS's decision to prepare an environmental analysis for the Liberty project. The MMS is aware of the information and technical analysis generated by the Northstar project, and will include the pertinent information from the Northstar draft EIS (published June 1, 1998) into the Liberty draft EIS, either directly or by reference.

Are the resource numbers correct?

The MMS has reviewed and analyzed both the public and proprietary information concerning the resources and proposed BPXA Plan. MMS feels the resource numbers are reasonable.

What is the seismic activity in the area?

There is very little seismic activity in the area, thus, it is not a factor in the design and safety of the project, and will not be analyzed further in the EIS.

The EIS should plan for catastrophic events and incorporate them into the Liberty design?

The NEPA requires that MMS look at reasonably foreseeable activities and analyze the environmental effects associated with those activities. The MMS will include analysis in the EIS for a very large but very unlikely oil spill. However, it does not seem reasonable to analyze the potential of other very unlikely catastrophic events.

Will the pipeline engineering process be open to the public?

The pipeline review process with the State Pipeline Coordination Office (SPCO) is open to the public, and the data and the analysis are available for review by the public at the SPCO office. The MMS and the SPCO have entered into a Cooperating Agency Agreement. Review of the Federal portion of the pipeline is also open to the public from both MMS and the SPCO.

Will MMS evaluate the OSCP in the EIS?

The Oil Spill Contingency Plan, which identifies the response capabilities, will be distributed for public review and comment with the draft EIS. Also, Section II and III of the EIS discuss oil spill response capability and the effects on the resources if a spill event occurs and hits the resource, but the EIS does not assume any level of clean up in our oil spill analysis.

Why develop these oil and gas resources now? Why not save them for later?

BPXA purchased the rights to develop these resources from the Federal Government in Sale 144. The decision to develop the Liberty prospect now is based on a variety of considerations, including logistics, economics and infrastructure associated with the development of the adjacent Badami oil field being developed by BPXA. The Liberty offshore pipeline will tie into the Badami onshore pipeline. Development of domestic oil and gas resources is consistent with the Outer Continental Shelf Lands Act and

U.S. Department of Energy (DOE) Policy. The USDOE is very concerned with the high level of foreign oil and gas imports and our dependence upon those foreign energy resources, and thus supports OCS development.

Will MMS help fund requests for additional subsistence data that are to be conducted by the NSB Wildlife Department for inclusion in the EIS?

The MMS does not anticipate the need to request additional subsistence information or data from the NSB Wildlife Department. We have cooperated with the NSB in previous MMS-funded studies, and we consider currently available information to be adequate for the analysis in the Liberty EIS.

Will MMS evaluate causeways and other structures in the nearshore waters that could adversely affect water quality and fish migration?

The plan submitted by BPXA does not include a causeway or other nearshore structure that might affect fish migration or water quality.

Comments received from the State of Alaska included comments from the Alaska Department of Fish and Game (ADF&G) concerning their preference for the proposed island design versus a plan that would include causeways. ADF&G also stated its preference for the proposed gravel mining site over other potential sites on the North Slope. Where appropriate, these preferences have been used in the evaluation of alternatives; MMS appreciates the position taken by ADF&G concerning those issues.

Will MMS seek the consent of the indigenous people, keeping in mind that the Alaska Native Claims Settlement Act Corporations do not have the authority under international law to speak for the traditional Inupiat people?

MMS is working with the State of Alaska, the NSB, the City of Barrow, and the village leaders in Nuiqsut and Kaktovik. Everyone is invited to attend our meetings and to voice their opinions and concerns. These concerns and issues are considered here or in the main body of the EIS. The draft EIS will be available to everyone for review and comment. The MMS feels this coordination is adequate.

E. ALTERNATIVES TO BE EVALUATED IN THE EIS

The CEQ guidelines require an agency identify and evaluate reasonable alternatives to the proposal for consideration in the EIS, and for alternatives which were eliminated from detailed study, briefly discuss the reasons for their having been eliminated (40 CFR 1502.14). "Reasonable

alternative” means feasibility, practicability, environmental benefit, meets statutory requirements of the OCS Lands Act, Rivers and Harbor Act of 1899, the Clean Water Act, etc. Under the CWA 404(b)1 guidelines, The Corps of Engineers must evaluate technically feasible and reasonable alternatives which have a lesser impact from the project on the environment. Based on issues and concerns identified during scoping, the MMS has evaluated and determined, for the reasons stated, the following alternatives to BPXA’s proposal will be analyzed in the EIS.

1. Alternative I, The Proposal

The MMS will evaluate the environmental impacts of the BPXA proposed action as described in the Development and Production Plan.

2. Alternative II, No Action

The EIS will include a “No Action” alternative as required by NEPA.

3. Alternative III, Southern Island Location and Eastern Pipeline Route

At the Barrow Scoping Meeting, one individual suggested that MMS look for alternatives that would use an island located in 15-20 feet of water, because such a location would reduce the impacts to bowhead whales. In evaluating this suggestion, it was discovered that most locations that meet the criteria were too far away or placed the island closer to the Boulder Patch. Because of the oblong shape of the Liberty prospect, extended-reach drilling already is being used. To move the site off the Federal lease into 15 feet of water would increase the risks and costs. It also would decrease the amount of resources that could be extracted such that the prospect would no longer be economically feasible. In effect, the alternatives would become the same as the no action alternative. The MMS did identify one site near the southern boundary of the Federal lease in 20 feet of water. It is located along the alternative eastern pipeline that was considered by BPXA in its evaluation process. This location is farther away from the Boulder Patch than the proposed island location, and it reduces the offshore pipeline length requirements from 5.5 miles to approximately 4 miles. However, this location increases construction of the onshore portion of the pipeline by more than a mile and will require additional drag-reducing agents to be added to the product in order to maintain product flow.

The MMS is including this Southern Island Location and Eastern Pipeline Route as an alternative in the EIS. This

alternative is supported by the Corps, EPA, and the NSB for analysis in the EIS.

4. Alternative IV, Use Steel Sheetpile to Protect the Upper Slope of the Island

A major issue identified in scoping in Nuiqsut and in Barrow was whether the gravel bag island design is adequate, and whether the gravel bags present a threat to navigation and to the environment. In the EIS, MMS will analyze an alternative island construction design using a steel sheet pile wall (as at Northstar) rather than the gravel bags. Analysis of this alternative is supported by the Corps, EPA, and the NSB.

5. Alternative V, Use Duck Island as the Gravel Source

Several commenters suggested that the existing Duck Island gravel mine site should be examined as the source for gravel extraction for the Liberty project development. Analysis of this alternative is supported by the Corps, EPA, and the NSB. The Duck Island mine site (about 90 acres) is located within the Prudhoe Bay Unit. The mine site is within the Sagavanirktok River Delta between the east and west channels of the river and on the north side of the Endicott Access Road about 6 miles south of the mouth of the river. It is bordered on the west by Washout Creek and on the East by Duck Island Creek. Most of the mine site is covered by water, primarily from melting snow in the spring and rain during the summer. The mine site has estimated reserves of 13 million yards of useable gravel if the pit is mined to depths between 70 and 75 feet. Currently, the mine site is used primarily as a source of gravel for ongoing maintenance of roads, the Endicott causeway, and islands. Approximately 1,300,000 cubic yards of overburden are stockpiled around the north, east, and west perimeters of the mine site.

In order to mine the Duck Island site, water needs to be pumped into designated receiving waters (Washout Creek, Duck Island Creek, and adjacent wetlands as authorized by the NPDES permit. BPXA estimates about 600 million gallons of water occupy the site. The current maximum rate per day is 1.5 million gallons authorized by the NPDES permit and it would take approximately 400 days of pumping to drain the site. If this site is chosen, then BPXA may need to modify or apply for another NPDES permit to pump at a higher rate. If a higher pumping rate is not approved, then this option would result in delay of the project for at least a year. This site has an approved rehabilitation plan that includes islands for nesting for birds and a lake that will provide overwinter habitat for various fish species.

Since this is an existing active gravel mine site, the surface disturbances have already occurred and the rehabilitation plan will occur after the site has been mined. There would still be about 12 million yards of gravel remaining after the gravel removal for Liberty, and the site rehabilitation would not occur until abandonment, between the years 2010 and 2015. This alternative will be analyzed in the EIS.

6. Alternative VI, Bury the Pipeline Deeper

During the scoping meetings, several people suggested that we bury the pipeline deeper. The MMS and the State Pipeline Coordination Office are evaluating BPXA's proposed pipeline design. The trench and burial depth are among the many factors that will be considered. This alternative is being prepared should the technical review determine a depth greater than BPXA's proposed 7-9 foot depth is needed to ensure the safety and integrity of the pipeline. The alternative includes an evaluation of the pipeline trench and burial depth to a maximum of 15 feet.

F. ALTERNATIVES EVALUATED IN THIS SCOPING REPORT BUT NOT ELSEWHERE IN THE EIS

A number of other potential alternatives were identified during scoping. Potential alternatives identified included alternative island construction design types, existing sites, alternative locations; alternative pipeline routes, and alternative gravel sources and mine sites. For the reasons stated, MMS has evaluated and determined that the following suggested alternatives do not warrant further detailed analysis in the EIS:

1. Alternative Island Construction

A number of different island locations and design types were identified during the scoping process as potential alternatives to the proposed Liberty Island site location. In assessing commenters' suggestions, MMS has evaluated the various locations in the Scoping Report, such as the use of satellite facilities to Liberty, using existing Tern Island instead of building another island, moving the island into shallow water, building a caisson-retained island, or developing the Liberty prospect from onshore using extended-reach drilling. For the reasons stated, the MMS determined that further analysis of these alternatives in the main body of the EIS was not warranted or required.

Will satellite facilities be necessary?

A concern was raised during scoping that the existence of the Liberty development could trigger incremental development in the area that would otherwise be uneconomic. The MMS has evaluated the Liberty reservoir and potential for satellite facilities based on both BPXA's and MMS's independent assessments. A satellite facility is one that has limited drilling capabilities but no processing facilities; for example, the Endicott Facility has a main production island (MPI) and a satellite drilling island (SDI) to the southeast of the MPI. The MMS believes that BPXA's proposal is appropriate for developing the Liberty reservoir. There is no evidence to indicate that a satellite facility currently is necessary or would be necessary in the future to properly develop the reservoir. In fact, the cost of an additional satellite facility would make the project uneconomical given our current assessment of costs and potential revenues from the oil and gas resources. Section 3 of the DPP includes provisions for evaluating additional prospectivity of the reservoir as new well information is obtained. The major design feature allowing this evaluation is the inclusion of more well slots than needed for development of the currently delineated Liberty reservoir. Those slots could be used in the future for appraisal or development well drilling. If economically recoverable prospects were defined by drilling from Liberty Island, the plan would be to use existing island infrastructure for production of those hydrocarbons.

Can the lessee use Tern Island to develop and produce Liberty resources?

The Tern Island remnant is located about 1.5 miles from the proposed Liberty Island site. Similar to an onshore development option, development from Tern island would necessitate high departure wells in the range of 18,000-22,000 feet to complete production wells in the structurally high portion of the reservoir. While some of the Liberty reservoir probably could be produced from the Tern Island location, the largest volume of reserves are located to the far west and would be more difficult and expensive to be produced. Development from Tern Island would not allow for the highest recovery of resources for the Liberty development area. Proper and efficient depletion of the reservoir is mandated by the OCS Lands Act, and it is in the public interest to ensure fair return to the public through royalty. The MMS does not consider development of the Liberty reserves from Tern Island to be technically preferable to the proposed Liberty site. Potential impacts from the use of Tern Island include increased risks of well control and more deviated wells, which increases the waste stream. Waste streams from more deviated wells would be ground and injected into a disposal well.

Can the island location be moved into 6 feet of water or less?

Similar to the Tern Island or onshore development option, moving the island location farther away from the reservoir only serves to reduce the volume of recoverable reserves; see the response to the comment on the Tern Island Alternative. Moving the island to the 6-foot water depth would result in well offsets in the range of 25,000-27,000 feet. This would make the project cost prohibitive. The MMS does not consider such an option to be in the public interest or to meet the legal obligations of the OCS Lands Act.

Various type of islands could be considered for this project. Most of them were considered for the Northstar project and additional information and analyses is included in Chapters 3 and 4 of the Northstar draft EIS. The Liberty Development and Production Plan and Environmental Report discuss other options considered by BPXA and provide the rationale for why these options were not considered any further. The MMS has reviewed all of these documents and analysis and concur with those decisions.

Can a caisson-retained island be used instead of a gravel island?

The caisson-retained island (CRI) was used to drill three exploration wells in the Beaufort Sea. The rig would require redesign and extensive modification before it could be used for this project; currently, it is uneconomic to proceed in this direction. The CRI, as is, could be used as a drilling surface but is inadequate for all of the other facilities. A gravel island surrounding the CRI still would need to be constructed, and the environmental effects would be similar to those in the proposal.

Can Liberty be developed from onshore?

Development of the Liberty field from onshore would require extended-reach drilling and completions, with stepouts in the range of 25,000-40,000 feet. The current record for a development/production well is 18,000 feet. Further discussion of extended reach drilling is available in the Northstar draft EIS, Chapter 3. The MMS does not believe that the development of the Liberty field from an onshore location is technically viable, and this option would be cost prohibitive.

2. Alternative Pipeline Routes

Several alternative pipeline routes were considered in MMS's evaluation of potential alternatives to BPXA's proposal. The proposed pipeline route avoids environmentally-sensitive benthic-boulder patch habitats, avoids areas of deep and frequent ice scour, and comes

ashore at a landfall site avoiding coastal wetlands and areas with highest erosion. The scoping process also identified potential alternatives, including using Endicott facilities and corresponding pipeline to Endicott, using the Badami processing unit and pipeline route, requiring use of casing around the proposed Liberty pipeline, using a remote-sensing system in the middle of the pipeline for monitoring potential breaks, and burying the pipeline in deeper water. In assessing suggestions, MMS has evaluated these comments as follows and, for the reasons stated, determined that analyzing these alternatives further in the main body of the EIS was not required.

Is it reasonable to use the Endicott facilities and construct a pipeline to Endicott?

This alternative would require pipeline construction through the environmentally sensitive "Boulder Patch." The pipeline would carry crude oil with dissolved natural gases and some water to Endicott. Control of internal corrosion and leak detection would both be more complex than what is being proposed. The processing facilities on Liberty Island would include primary stages of production separation and complete gas dehydration and compression, as in the proposed full processing. This alternative was dropped because of the potential environmental consequences to the Boulder Patch. BPXA rejected the Endicott option for reasons in addition to minimizing environmental impact, including technical uncertainty and no economic advantages.

Can the lessee use the Badami processing unit and pipeline route?

If no processing takes place on Liberty Island, then the pipeline would carry carbon dioxide, water, natural gas, and crude oil. Internal corrosion potentials would require the pipeline to be made from special corrosion resistant alloys. Pipeline leak detection is more difficult (less sensitive) for three-phase pipelines (water, natural gas, and oil) than a single phase oil pipeline. During low flow periods, the temperature may fall low enough to enable hydrates to plug the pipeline. Issues related to carrying three phase flow to Badami for processing are the same for processing at Endicott, but the pipeline to Badami would be much longer.

Can the pipeline be designed with a casing around it to contain and allow monitoring for oil leaks? Can the pipeline be directionally drilled through the transition zone?

Casing is used to protect pipelines from external loads such as in deep horizontal directionally drilled river crossings or under a road bed. The magnitude of the external load from an ice keel is beyond the level of protection provided by casing. BPXA's proposed burial depth is intended to be sufficient to avoid damage or unacceptable strain on the

pipeline. This design will be reviewed and verified by MMS and SPCO prior to any pipeline approval. In any case, using casing as a secondary containment measure is not without problems. Industry experience shows that buried casings are a prime location for corrosion. The best efforts to electrically insulate the pipeline from the casing do not prevent a small amount of moisture from providing an electrical path. Once this occurs, it is nearly impossible to know the direction of current flow or to control it. The worst case is if the pipeline becomes anodic in relation to the casing, meaning the pipeline is actively corroding and the casing is being protected. The annular space between the pipelines is normally vented to the atmosphere. The use of various monitoring devices, such as pressure-sensors and pigs in the pipeline, are effective means to detect pipeline leaks.

To directionally drill the pipeline through the transition zone, it would need to be installed in casing, which exposes the pipeline to potential corrosion and other problems.

Wouldn't an additional remote-sensing system in the middle of the pipeline provide useful information?

The proposed pipeline is only about 7.5 miles long. Installing instrumentation at the midpoint would yield very little information that would contribute to pipeline integrity. All of the pipeline segments are welded except for flanges at the very ends. Each weld is thoroughly inspected. Welding the pipeline segments together provides the highest level of protection against leaks. Installing instrumentation at the midpoint would most likely require a threaded or flanged connection. These types of connections do not have the integrity of a weld and would be more subject to leaks. The instrumentation would require a power source and a communications link to Liberty Island.

Can the pipeline be buried deeper to make it safer?

It is technically feasible to bury the pipeline deeper than the 7 feet currently proposed if the final technical review of the pipeline indicates that deeper burial is necessary to ensure the pipeline is safe. Proper burial depth will be a function of multiple factors including soil conditions, pipeline operating conditions (temperature), external loads, and pipeline material specifications. BPXA's proposed burial depth will be fully evaluated during the MMS and SPCO detailed technical review of the pipeline design. If the technical review verifies that the proposed design is sufficient, there would be no basis or increased safety to the pipeline to indiscriminately require deeper burial. To do so would only serve to place additional and unnecessary loads on the pipeline from additional overburden, and complicate the timing and ability to install (and, if necessary, repair) the pipeline. Although the EIS will not analyze the adequacy of the pipeline safety (which is conducted through the MMS and SPCO right-of-way process), the EIS will analyze the

effects of constructing a 15-foot trench in the event the final pipeline review concludes that deeper burial is necessary (see section IV, Alternative VI, Bury the Pipeline Deeper, of this report). BPXA has indicated that a 15-foot trench is the economical limit for the Liberty project; an additional alternative for deeper trenching will not be evaluated as a viable alternative.

Why not use horizontal directional drilling from a series of islands to get a pipeline from shore to the production island?

Current horizontal directional drilling technology for soil conditions along the route is limited to about 5,000 feet. This method would require about six satellite island locations. Each island would need to be large enough for a horizontal drilling rig and all associated support equipment, probably close to the size of exploratory drilling islands. Drilling fluids and cuttings would still have to be disposed of. The pipeline would be inside of a casing potentially causing cathodic protection problems. The finished pipeline would be undulating and poorly aligned, potentially causing flow and measurement problems. The engineering complexities of this proposal make it prohibitive.

3. Alternative Gravel Sources

During scoping, several individuals asked whether BPXA had considered alternative gravel mine sites from which to obtain gravel for the Liberty project. Potential alternative gravel sources could include using the Kadleroshilik River Oxbow site, the existing Duck Island mine site, an island in the Sagavanirktok River, or the nearby abandoned Tern Island. The MMS evaluation determined these alternative gravel sources, other than the Duck Island mine site, do not require further analysis in the main body of the EIS. The Duck Island Mine site will be analyzed as an alternative gravel location in the EIS (Alternative V, Use Duck Island as the Gravel Source).

a. Kadleroshilik Oxbow Mine Site

Can the Kadleroshilik River Oxbow site be used as a gravel mine site for the project?

Another potential gravel site is in a nearby Oxbow lake system on the Kadleroshilik River. This site is vegetated with tundra. Mining at this site would occur during the winter and, while it wouldn't cause direct harm to nesting birds, it could destroy potent nesting sites and feeding areas. Caribou also may feed on the tundra. While this site may provide a deep freshwater pool for overwintering fish, the disturbance to the existing vegetation would be much greater. The ADF&G believes that mining wetland

complexes potentially would have greater environmental impacts, certainly greater wetland impacts, than excavating the Kadleroshilik River. The mining of gravel from the oxbow lake would disturb more tundra vegetation than the proposed location, and the projected impacts would be greater than the proposed location. BPXA evaluated use of the Kadleroshilik Oxbow mine site prior to submitting its DPP.

b. Sagavanirktok River Site

Can a gravel mine site in the Sagavanirktok River be used?

The ADF&G has been working closely with BPXA to determine feasible gravel sites. The Sagavanirktok River already provides fish-overwintering habitat, while the lower Kadleroshilik does not. Potential gravel mine site locations in either the Kadleroshilik or the Sagavanirktok River could provide new overwintering habitat but the speed of colonization, species mix, and relative value to each system would differ. The ADF&G prefers a Kadleroshilik site for the Liberty Project because overwintering habitat is not currently present in the lower portions of this system.

The Kadleroshilik River has no existing overwintering habitat in the lower portion of the system; the proposed pit would add habitat that is completely lacking. Colonization of the pit would take place over several years, and some time may pass before the benefits are fully realized because existing grayling and Dolly Varden populations are adapted to overwintering in upstream spring areas. The pit may become brackish, although the pit design allows exchange with river flow. The Sagavanirktok River (Sag) has existing overwintering habitat in the lower portion of the system; the proposed pit would supplement a habitat that is present but limited. Colonization would be rapid because existing grayling and whitefish populations are adapted to overwintering in the lower river (Dolly Varden overwinter in upstream tributary rivers). The pit would remain as fresh water habitat if located in the upper delta, but would be brackish if located in the lower delta, although design of the pit would influence exchange with river flow.

In summary, a Kadleroshilik mine site would have a greater relative value in terms of creating habitat than would a Sag River mine site. In contrast, a Sag River mine site might have a greater absolute value in terms of fish numbers supported and species diversity (the Sag system supports many more species from the start), at least in the short term. The choice between systems with respect to mine site location ultimately may be a value judgment with respect to fisheries enhancement.

c. Tern Island Gravel

Can the lessee use gravel from Tern Island?

The existing gravel at Tern Island is both insufficient and unsuitable as a gravel source. The gravel at Tern island is frozen in place and would require more extensive mining (including potential blasting and dredging) and processing of the gravel to make it suitable for reuse at the Liberty site. Several seasons would be necessary to mine the gravel at the Tern island, extending the overall construction season for the Liberty project and causing multi year effects to the offshore construction area. Available gravel at Tern Island is insufficient to accommodate Liberty. Additional gravel sources would be required, with resultant spatial and temporal disturbances. The MMS does not believe the Tern Island gravel provides a reasonable alternative gravel source that provides the properties necessary for the proper, safe, and timely engineering and construction of the Liberty development island and would result in an overall increases in impacts.

d. Other Mine Sites

Are there other gravel sources that could be used?

Although other abandoned gravel sources exist, none of the sources reasonably near the site are considered to be large enough, and additional testing would be required to determine if there is contamination in the gravel. Because none of the sites is adequate to meet the total gravel needs of the project, the proposed gravel site still would be required.

G. PERSONS WHO ATTENDED THE SCOPING MEETINGS

Nuiqsut, March 18, 1998

Phil Allison
Jonny Ahtuanguaruk
Tom Cook
Sarah Kunaknana
Leonard Lampe
Thomas Napageak
Isaac Nukapigak
Lucy Nukapigak
Joe Nukapigak
George Sielak
Eunice Sielak
Fred Tukle, Sr.

Barrow, March 19, 1998

Duncan Adams

Bart Ahsogeak
 Dr. Tom Albert
 Arnold Brower
 Harry Brower, Jr.
 Ronald Brower, Sr.
 Karen Burnell
 Mary Core
 Jon Dunham
 Taqulik Hepa
 Jay Marble
 Emily Nusunginya
 Taqulik Obie-Hepa
 John Tichotsky
 Jim Vorderstrasse

Anchorage, March 25, 1998

Phil Allison
 Melanie Duchin
 John Ellsworth
 Katie Farley
 Glenn Gray
 Peter Hanley
 Bill Higgs
 Jim Lewis
 Pamela A. Miller
 Kristen Nelson
 Erik Opstat
 Simon Potter
 Dan Rice
 Ted Rockwell
 Caryn Rosenberg
 Jim Sykes
 Mary Weger
 Karen Wuestenfeld

Kaktovik, March 31, 1998

Berdell Akootchook
 Daniel Akootchook
 George Akootchook
 Isaac Akootchook
 Walt Audi
 Archie Brower
 Tom Cook
 Leonard Gordon
 Susan Gordon
 Roland Kayotuk
 Fenton Rexford
 Chris Ruthven
 Lon Sonsalla
 Sharon Thompson
 Merylin Traynor

Fairbanks, April 1, 1998

Sara Callaghan
 Kathleen Done
 Frances Mann
 Ann Morkhill
 John Ringstad
 Chris Ruthven

Pat Sousa
 Eric Taylor

Anchorage, April 8, 1998

Ron Barnes
 Charles Bingham
 Tim Bradner
 Geoff Butler
 Janet Daniels
 Melanie Duchin
 Katie Farley
 Peter Gadd
 Jeanne Hanson
 Al Larson
 Jim Lewis
 Stacey Marz
 Pam Miller
 Chris Ruthven
 Sallie Schullinger
 Marlo Shedlok
 Richard Sloan
 Jay Stange
 Don Williams
 Karen Wuestenfeld

Liberty Information Update Meetings (MMS, 2000)

This appendix was published as part of the Liberty Development and Production Plan (DPP) Draft Environmental Impact Statement (EIS) and was not revised for the Final EIS. The reader is referred to this appendix in the Draft EIS. This appendix is also available on the CD-ROM (MMS 2002-019 CD) and on the Internet (<http://www.mms.gov/alaska/cproject/liberty>).

Appendix E-2

Liberty Information Update Meetings

by Minerals Management Service, March 23, 2000

Five meetings were held:

- A. Fairbanks, October 28, 1999
- B. Barrow, November 1, 1999
- C. Nuiqsut, November 2, 1999
- D. Kaktovik, November 5, 1999
- E. Anchorage, November 9 and 10, 1999

A. FAIRBANKS

October 28, 1999,

7:00 pm at the Noel Wien Public Library

MMS Attendees were:

Paul Stang, 271-6045
 Fred King, 271-6696
 Dave Roby, 271-6557

Attendees:

Julene Abrams, 455-8073, 100 Cushman St, Suite 201,
 Fairbanks, AK 99701
 Jim Aldrich, 455-8073, 100 Cushman St., Suit 201,
 Fairbanks, AK 99701
 Charles Paskvan, 456-2537, 1028 Dogwood, #404,
 Fairbanks, AK 99709
 Gabe Strong, 452-5123, 205 Madcap Lake, Fairbanks, AK
 99709
 John Ringstad, 456-6891, 757 Illinois St., Fairbanks, AK
 99701
 Karl Hannamen
 Cliff Burglin, 17 Adak St., Fairbanks, AK 99701
 Moon Lew, 564-4530, BP Exploration, P.O. Box 196612,
 Anchorage, AK 99519
 Karen Wuestenfeld, 564-5490, BP Exploration, P.O. Box
 196612, Anchorage, AK 99519

Charles Paskvan said that over-dependence on foreign oil was a problem 25 years ago. We had oil embargoes in the 1970's and gas rationing. We are an oil resource based State and we should be supporting new development, which leads

to a strong and healthy economy. The best thing we can do is have new fields come on line.

One individual has been working on the Northstar project. His job was coating the pipeline with fusion bonded epoxy (FBE). He personally did poly coating on every elbow on the pipelines of Badami and Endicott. He heated pipe to 480 F and sprayed on a furim-based coating (plastic coating) to protect pipe from corrosion. He has personally seen the quality of work and has confidence in the quality of the workmanship and the integrity of the pipelines being built. He said "The sooner the better for development of Liberty."

We should be supporting additional production.

One person asked whether there was any basis to do a risk assessment of the depth of strudel scour and ice gouging. What is the ice and strudel scour data for the proposed pipeline route? Dave Roby responded with a general answer. With strudel scour, is there a correlation between the size of the river, the water depth, and the amount and size of strudel scour?

The MMS process takes too long. The projects are geared for big operators, and don't allow small operators to join. MMS should treat small independent operators differently than big operators.

In 1977 Hickel said there were 600 billion barrels of oil in Alaska. We should lease the whole state and live off the leases.

B. BARROW,

Nov. 1, 1999,

7:00pm at the Inupiat Heritage Center

Attendees:

Dr. Drew Hageman, Ilisagvik College
 Charles Neakok, Native Village of Barrow

Harry Brower, Jr., NSB Wildlife Management
 Maggie Ahmaogak, AEWG
 R.E. Peetook, AEWG/Wainwright
 Abel Akpik, ICAS
 Tom Albert, NSB Wildlife Management
 Paul Kinglow
 Johnny Aiken
 Edna MacLean, Illisagvik College
 Jane Combs
 Taqulik Hepa, NSB Wildlife Management
 Norm Goldstein, KBRW-AM News
 Ned Arey, NSB Planning Dept.
 Rex Okakok, Head, NSB Planning Dept.
 Doreen Lampe, NSB Planning Dept.
 Anne Jensen, Barrow Arctic Research Consortium
 Fred Kanayurak, Pres. Barrow Whaling Captains,
 Ronald Brower, Inupiat Heritage Center
 Maribel Izquierdo-Rodriguez, Inupiat Heritage Center
 Charles Brower, Head NSB Wildlife Management
 Arnold Brower, Jr. ICAS
 Jana Harcharek, IHLC

The meeting began at 7:00pm with MMS introducing its team: Paul Stang, Fred King, Albert Barros, Dave Roby, and Mike Burwell. At Fred's request the audience introduced themselves, and then he began his PowerPoint presentation that gave an intro. to the Liberty Project, discussed the delay, ongoing project planning, schedules, alternatives, and issues. The presentation concluded with Mike Burwell giving a brief presentation on Environmental Justice.

People felt free to stop Fred and ask questions. What follows are their comments and concerns:

Edna MacLean was concerned about pipeline alternatives and wondered how MMS was going to do an Oil Spill Risk Analysis (OSRA) for each pipeline alternative/design. Dave explained it would be a failure probability computer analysis done by the firm, INTEC . Maggie Ahmaogak asked if the test would happen in a particular Arctic location, and Dave said it would not be onsite but done by computers in a laboratory setting. Drew Hageman wondered if these analyses would be looking at local and actual environmental conditions and Fred said no that it would be a computer analysis of data.

Maggie A. wondered who would determine what would break a pipe. "Do they know enough local knowledge of ice movements?" She said locals say ice can gouge 6 to 9 feet into the sea floor and believes a pipeline is still not safe at 8 feet. It's 6 to 9 feet for Northstar, so why not the same for Liberty? Dave responded that the State Pipeline Coordination Office and the MMS contractor raised several issues regarding BP's statistical analysis of ice gouging and strudel scour and that new models are being prepared by BP.

Edna M. asked if we were considering the knowledge of whaling captains. Fred said we were and that their concerns and information are in the EIS. Also, when the DEIS comes

out the whaling captains can comment on our treatment of their information. Paul Stang added that MMS was working on getting better data/spill statistics for the Arctic, was doing a number of conceptual studies, developing a new statistical approach, and was including much new traditional and technical knowledge.

Jana Harcharek mentioned that the Inupiat History, Language, and Culture Commission (IHLC) had many Traditional Knowledge (TK) sources (tapes, written sources) for ice dynamics. She asked about the agencies participating and Fred listed who the cooperating and participating agencies were for Liberty. Paul added that the agency distinctions in Liberty are not the same as those used for Northstar, and that it was our intention to have the broadest cooperation/participation from affected agencies as possible.

Edna M. asked how MMS made a particular TK observation into a data point for analysis. Mike talked about the MMS TK Study being done by UIC in Barrow and that part of the study was to develop just such a protocol for using TK in the way she was asking. Paul stressed that MMS would always try to be respectful in using TK and did not want to pit Western science against TK.

Arnold Brower talked about his work as a NSB Coordinator for NPR-A and wondered if by being a cooperative agency on Liberty an agency's right to litigate was protected. Paul said that the right was protected and that there were no hard and fast rules for these agreements. Fred interjected that the NSB cooperating agreement gives them the right to litigate.

Doreen Lampe said that in terms of participation, village concerns were very important but that a conference call from the villages was a long distance charge. Paul said MMS was happy to come up and meet with the communities whenever they liked and that Albert Barros, our Outreach Coordinator, would be the point of contact.

Rex Okakok said that with the turnover in administrations, the NSB Planning Dept needed time to study what's been done to this point and that NSB planning needed a participant in the Liberty planning process.

Maggie A. said that when the first Liberty scoping occurred, they were all involved with Northstar and she wondered if new scoping was needed for Liberty. Paul affirmed that this meeting was to accomplish just that, but that we certainly would come back if people thought it was needed. Maggie liked the idea of coming back because she wasn't originally contacted. She wanted to know what studies would be incorporated and stated that the Oil Spill Contingency Plan (for Northstar) was not adequate. "We are all worried about the Oil Spill Contingency Plan... We need a thorough review of it."

Paul explained that we wanted to include the new ongoing studies data in the DEIS and that we would be analyzing the OSCP. Maggie said that noise impacts [to whales?] would be double the ones we are accustomed to and that they were

opposed to this. They were trying to protect their interests [whales/subsistence] and are worried about the advent of subsea pipelines. They want to know if BP is using the best technology. Will the pipeline stand up to big huge icebergs that TK says are coming? Maggie says the elders don't think so: "We all need to discuss these things and be comfortable before the DEIS."

Fred Kanayurak told MMS that he had received no information about this meeting from AEWG, and the implication was that MMS had not done its job getting the word out to whaling captains. Because of this, he said there were only six whaling captains present, but if he'd known, he would have had a full house. He told MMS to get it right and invite everyone next time.

Arnold B. took MMS to task and assumed we'd be including lots of the Northstar narrative for under-ice cleanup. He objected to such an approach because it disregarded the destruction of sealife. Liberty is an area where whales go and belugas, especially, are in a drastic decline. He is concerned that if we follow the Northstar model that we will be telling people the situation is all right when things are dying. New and more solid research is needed on under-ice cleanup. There is no data on the effect of oil being left through the winter on fish and marine mammals, and this research then needs to be incorporated into the EIS. We need better research from you to properly address our Inupiat understanding of these things. There are fewer shrimp and octopus in stomachs of bearded seals, and belugas are going away in Kotzebue.

There needs to be a point of contact in Barrow. FWS had used Arnold B. as a local contact.

The elder Agutak [?], who had been patiently waiting, finally spoke in Inupiaq and Jana H. translated. Loosely quoted, Agutak said: I want to say this but will you listen? Wind makes the water table rise. Wind raises up the ocean. The winds start and get stronger. With winds and currents and rising water, conditions are very perilous. I have seen this more than several times in my life. Very large bergs get beached because of these strong forces. When a big berg moves against the ocean floor, they are like big bulldozers. Very forceful. These icebergs weigh a lot. Because I've seen this more than once, I am fearful of what will happen to a pipeline under the ocean floor because I have seen all this happen. I wanted to share this with you.

Abel Akpik supplied us with a written that he proceeded to read. He told MMS to "Cease and desist all activity on Liberty," and that ICAS was opposed to Northstar from the beginning. ICAS thought its comments on Northstar would be recorded and used because these comments are meant to be heard and weighed. "We at ICAS will fight offshore development." Abel went on to demand that the Chukchi Sea communities be included in the Liberty planning process. They need to be included in the public hearing process. Paul thanked him for his comments and responded

that he would take his written statement and this request back to John Goll.

Ron Brower asked about future schedules and noted that we were doing these projects piece by piece when we should be doing cumulative impacts. He believes new data and new projections are needed. There needs to be a new blueprint from aerial flights to underwater impacts. Paul explained how Liberty fit into the overall matrix of lease sales (Sale 176), the 5-year, and the energy needs of the nation. He explained how a draft development plan from industry tripped the process for writing a development EIS—in this case Liberty. He said that at this time MMS had no other development plans. He also made it very clear that MMS was working on a better process for cumulative effects analysis. Mike and Paul explained a bit about ongoing MMS studies—ANIMIDA and BWASP--that pertained to cumulative effects.

Ron B. talked about the potential destruction of habitat—from whales to krill—from development, asserting that "loss of habitat was a loss of opportunity." Will ANIMIDA address this concern? He talked too about tidal wave action in the Arctic and how at Cape Simpson ice was pushed 1,500 feet over gravel islands on the mainland. MMS needs to look into the question of earthquakes affecting tidal action. He also mentioned the need for impact assistance, and Paul said MMS had just talked to Mayor Ahmaogak about it the same day. Paul described his history with impact assistance and agreed it was a major issue. Mike said he thought it was time for a sociocultural study like ANIMIDA, and that a good way to address many of these concerns was by getting your study ideas into the MMS study process. One participant stated that MMS needs to make its monitoring program the top priority before actual construction starts.

Arnold B. wanted to know where MMS stood on the position ICAS took at a meeting at Alyeska where they and 40 coastal communities put forth their comments on impact assistance. Paul said that MMS was working hard on the issue, that the MMS director supported it, and that our efforts will continue. He said, however, that he personally was not very optimistic about impact assistance given the current situation in Congress. Arnold said that "We [the Inupiat people] need some compensation for dealing with your projects...you sever our lifestyle, [so] we look at it like a severance tax."

Abel A. said that biological studies were needed for Northstar, and that they were not done. He called FWS about this and the only thing they talked about was eider ducks. There was nothing about polar bears or whales, yet the project was permitted. He questioned Alaska Clean Seas doing spill drills during a calm part of the year (August) and not in other conditions.

Maggie A. agreed that the compensation issue was important, and that she had already talked to Albert about compensation language for impact assistance. "The OCS got

lots of money and we don't get any." "What about compensation to whaling captains? How will conflicts be resolved - who will pay?" She said that MMS can expect them to be more aggressive in the public forum for Sale 176 because "we need to get something concrete done. We're tired of repeating ourselves..." Maggie A. said "We know the money is being stolen from our ocean out there. We need something...1% of the lease sale. Put something in writing and go forward paying for impacts." Fred talked briefly about 8 (g) monies and how 27% goes to the State and that how it isn't passed on to the NSB.

Maggie A. talked about the bowhead census that they need to do every 5 years and that even with the money they get from NMFS, they don't have enough to cover census expenses. They are presently getting \$100,000 and that doesn't cover expenses. Maybe MMS could contribute \$100,000 for the census... "One gives the quota [NMFS]; one sells the ocean [MMS]."

Harry Brower, Jr. wondered if wave action had been considered in pipeline and island design. Fred said that it had been folded into the considerations for strudel scour considered on any pipeline that crossed in front of the Sag River Delta. Maggie asked a question about how deep the permafrost was under the undersea portion of the pipeline. Paul said we would get an answer for her.

Paul talked about the "sniffer" tube monitoring system and there was ongoing discussion with Arnold B., Maggie A., Harry Brower, Jr., and Peter Hanley. Paul explained how there was a continuous check always happening when the system is working. Abel A. wondered if the material coating the sniffer tube would be affected by the Arctic environment.

Arnold B. wanted to know how we could assure quality control. Peter Hanley explained that the Siemens people would install the system and check it once a year, and that the hydrogen in the line will accomplish the check to see if it's operating. European systems have been working for many years. Paul added that the key is proper installation. Maggie wondered where the check points were for the system. Peter Hanley said at either end and that there were no intermediate valves or checks along the line. An extra valve increased the likelihood of a leak. He conceded that gouging or line failure in the middle of the line would cause a leak.

The question was raised about how the pipe would be repaired under ice. Moon Lew said it depended on the conditions, as they would be very different between open water and when the ice was frozen fast. Arnold B. suggested a "reverse pump" that would pump oil back to shore and the island. Abel A. observed that if both pipelines broke you would have oil and gas in the environment. Paul explained leak detection in more detail and the pumping shutdown procedure.

Harry Brower asked what the underlying purpose was for this meeting and Paul said it was to explain the slowdown in the Liberty process, restate the concerns we'd heard in scoping, to field new concerns, and to fold all this into the DEIS process.

Doreen Lampe wanted to know who to call for all the different parts of the process: EIS concerns, OSCP concerns, pipeline concerns, oil spills, etc., and Paul said we needed to make this all clearer.

Taqulik Hepa wanted to know if there was a response plan for Liberty. Someone said that it would be addressed in the DEIS.

Jana H. said we must properly address effects to human beings. She said that this was not done adequately for NPR-A. She cited (Sec. 4.4 or Sec. 6-607?) a part in the Executive Order for Environmental Justice (EJ) where it described the need to pay for subsistence data collection and suggested it created a mechanism for Federal money to go directly to the NSB Wildlife Management Dept. to help them in their ongoing community subsistence surveys. She believes the EIS process needs to pay greater heed to addressing the human element in the EIS process and that it was not done in previous EIS's. Mike talked about how MMS addresses EJ. Maggie A. said "So who's going to fix this EJ? MMS? MMS and us?" Regarding EJ, Taqulik H. said that now was the time to get a Subsistence Advisory Panel going, before, not after, development activity begins.

Ron B. mentioned how agreements between Alyeska and the State guaranteed 25% of the pipeline jobs go to Natives and that that never happened. In this light, he wondered what assurances MMS and BP could make about the promises for Liberty. Paul said MMS could not require Native hire of BP. Edna M. asked if there were training programs for Natives in impacted areas and did the University of the Interior have any programs.

Jana H. cited some BLM guidelines that specified particular types of consultation, and asked if MMS had similar guidelines.

Maggie A. requested that MMS take into account cumulative risks and compensation for impacts and that past mitigating measure—that were the product of extensive consultation with the AEWC and others--be included in any new actions, so people know what happens when and who will do what. She affirmed that all communities need to take part in the EJ process.

Doreen Lampe mentioned a Nov. 4th meeting in Barrow on contaminated sites with the Navy, the Army Corps, EPA, and the State to figure out the why, when, and where of cleaning up contaminated sites in the vicinity. In terms of contamination, she said the onshore has had enough.

Tom Albert spoke last and offered 7 observations/points to consider:

- (1) Mayor Ahmaogak has stated in his Sale 176 comment letter the Borough's position on offshore development.
- (2) There are still oil spill problems; cleanup in ice is still a problem for people on the Slope. The "sniffer" tube idea is interesting and we need more info.
- (3) Noise effects are still an issue. With Endicott, Northstar, and Liberty, you have a chain of development. Is this sort of chain going to push fall migrating bowhead whales farther out to sea? This is an ongoing concern.
- (4) Pay attention to local comments. I'm sure MMS will do this in the DEIS.
- (5) Use good study data; analyze honestly and correctly. The Bowhead Whale Feeding Study has limitations. Be careful or there will be confrontation.
- (6) We need good monitoring, and pay attention to results. We need a good monitoring process that is peer reviewed.
- (7) Seismic noise. An old MMS study showed the distance at which bowhead were disturbed to be 7.5 kilometers but now the area has increased to 12 miles due to new studies, but they start to react at about 30 miles. This is a real good reason to listen to what people say...and hear their fears. We don't want a fight on this like we had in the past. If the DEIS doesn't look good we'll be mad...

Doreen L. asked about what studies were used to determine where we leased. Paul explained MMS's basic mandate as an agency and how the 5-year program and lease sale processes work.

Taqulik H. asked that we communicate the concerns we hear in Nuiqsut and Kaktovik back to Barrow.

Maggie A. said they wanted another meeting so the whaling captains can voice their concerns and MMS can capture the TK. The end of January or the first week in February was discussed as a possible date, because this is the approximate date of the whaling captains' annual meeting. Her final comment was one EJ: "What are we going to do on EJ? You do more projects, but still there is no compensation."

The meeting adjourned at approximately 10:30 but the MMS team stayed later to discuss the finer points of certain issues with those who remained.

C. NUIQSUT

Nov. 2, 1999,

7:00pm at the Nuiqsut Community Center

Before the public meeting, we had a 2:30pm meeting with Mayor Leonard Lampe because he could not make the evening meeting; he gave us his concerns at this time:

Leonard Lampe's comments/concerns:

- ACS oil spill cleanup plans are not accurate.

- Local elders feel the waters are more different here than anywhere else in the world, making a spill in them impossible to cleanup.
- Noise from a production island will interfere with bowheads.
- Time of pipeline construction will cause disturbance. Fred and Paul assured Leonard that construction would occur almost entirely in winter.
- They have asked BP for a study of effects on Arctic cisco from construction and other activities in Camden Bay. They are seeing a decline in cisco now. BP has not responded to their request.
- The people in Nuiqsut want BP to study caribou in the area.
- Nuiqsut has concerns about the design of the Liberty island. Concrete won't work, and bags break down and cause environmental hazards to whales, seals, and polar bears. Paul and Fred described the new bag material and the sheet pile alternative.
- The village still has concerns about air pollution from Prudhoe Bay. State standards are not strict enough.
- Drilling wastes. Fred and Paul explained they will be reinjected.

After Fred and Paul talked about alternatives and alternate pipeline routes, Leonard said he preferred the direct route to shore and definitely did not like any pipeline routed toward Endicott. He thinks the permafrost where the pipeline comes ashore could be an issue. Fred explained the "sniffer" tube technology to Leonard, and he felt that such a system would give them "more confidence" about a pipeline.

Leonard told us that the City of Nuiqsut is going to hire in the next 3 months a local Cultural Guardian half-time position whose job will be to concentrate on development projects and permits. He will serve as a liaison between the village and industry and agencies such as MMS or the State. He will provide adequate local notification of meetings, read EIS's, comment at meetings, etc. The Cultural Guardian will also collect TK from the elders for any area slated for development. He will gather this TK and get it to industry and the appropriate agencies. Albert Barros said later that EJ may empower us & other DOI agencies to pay some of the Cultural Guardian's salary.

Leonard also talked about ice:

- Shorefast ice is the ice to look out for. Young ice comes and goes and causes unpredictable ice movement onto islands. On the east side of No Name Island [SE of Cross Island] they saw a piece of ice 50 feet thick and 100 feet wide while hunting ugruk in August. Now it has melted a lot, but they wonder how such a huge piece of ice could pass through the shallow water near Cross Island. They think it must have come from the south. Thomas Napageak said this sighting confirmed what he knew from old stories about ice movement from the past.

- Thomas N. gave BP a design for Northstar suggesting they build a recurved steel wall that curves the ice back on itself, but BP said they couldn't build a wall like this.

About oil spills:

- Leonard talked about past oil spill drills and that it is ACS policy not to go out on the ice if it's dangerous—even when those in Nuiqsut know it's safe. He described a spill drill where the Nuiqsut villagers were forced to take it over and become the trainers because ACS people couldn't perform in the conditions.
- We know about oil spills in ice and snow. "The high risk of an oil spill is what upsets people the most."
- Village Response Teams. He affirmed that BP has not utilized Nuiqsut. There used to be 12 members of the VRT, but they disbanded, and now there is only 1. BP says that ACS will get in contact with them but ACS doesn't. It is disturbing to him and the village that BP, for PR purposes, talks like their VRT is active. We want training in airboats, on booms, on ice so we can stay up to date with certification and get compensated at an acceptable rate.

About fish:

He said Nuiqsut is trying to set up a Nuiqsut Fishing Association because no one is looking out for cisco, broadfish, and whitefish. Fred asked if there would be a problem with a 500 foot causeway. Leonard said to talk to Sara Kunaknana because she knows about ice conditions in the area; she knows winds, currents, animals, the area around Prudhoe and Foggy Island Bays. She's the TK source for the area. She knows the Endicott area too and whales and birds.

About caribou:

Leonard said they don't see as many calving caribou as they did before. The Tarn well has changed their south/north migration and Alpine may affect their east/west migration. Caribou have to cross 3 pipelines now. There is some concern with the Liberty pipeline especially toward shore because it comes ashore in an insect relief area; for this reason, he'd like to see the onshore portion buried.

About aerial flights:

He doesn't want too many to come with development because there are already too many from local hunters.

Evening Meeting Attendees: Christopher Long, Annie Stern [Skin?], Marjorie Ahnupkana, Alice Ipalook, Lloyd Ipalook, Steve Leavitt, Dora Nukapigak, Virginia "Virgie" Kasak, Della Dreggs, Ruth Nukapigak, Richard Tukle, Frederick Tukle

The meeting began at 7:00pm with MMS introducing its team: Paul Stang, Fred King, Albert Barros, Dave Roby, and Mike Burwell; our interpreter, Virgie Kasak, introduced the people from Nuiqsut. Fred did his PowerPoint

presentation that gave an introduction to the Liberty Project, discussed the delay, ongoing project planning, schedules, alternatives, and issues. The presentation concluded with Mike Burwell giving a brief presentation on Environmental Justice.

People felt free to stop Fred and ask questions. What follows are their comments and concerns:

Before the meeting began, Steve Leavitt and Lloyd Ipalook were standing around talking to Mike Burwell about the fact that there are no fish right now. They think BP activities are driving them out. There are no caribou and helicopters are scaring the moose.

Paul began the meeting by introducing the MMS team

Ruth Nukapigak, the resident elder for the meeting, came in after Fred had started, and he backed up and showed her the Liberty area map.

After Fred got to the alternative pipeline routes, Ruth immediately voiced her concerns (in Inupiat—Virgie translated). She was very concerned that fish habitat would be disturbed by any routing toward Endicott. She knows the area well and feels it will be affected. In fact, all the alternatives will affect fish.

There was much discussion—in Inupiat—about the best alternative. They asked us if we were aware of gravesites on the shoreline of Foggy Island Bay, and we said we were not. They said that the other elders who would know more about this are Abraham Woods and Sara Kunaknana from Nuiqsut and Lucy Ahvakana from Barrow. The elders at the meeting could not remember where the gravesites were; nevertheless, they were concerned with the potential of disturbing them. Ruth N. preferred the pipeline that went straight south because it wouldn't affect migrating fish as much. She wanted to know the water depths and Dave R. showed her the map indicating depths of 22 feet. Again, she affirmed that regardless of the type of construction, there will be disturbance to fish. She said they've noted a decrease in whitefish since the work at Kalubik. There used to be 100-200 fish caught per day vs. 6 to 9 per day now. ["Freeze up till December—noticed change this year" = Does anyone remember the context of this statement?]

After Mike spoke on EJ and mentioned that Thomas Napageak had served on the OCS Advisory Committee, most everyone in the room said they didn't know what the OCS Advisory Committee was, didn't know Thomas N. was on it, and didn't even know how he had been selected. Mike explained the selection process, and they said that there were better ways to let the whole village know about things like this and public meetings: a fax to the village coordinator, the local powerplant, other city departments (Leonard has a list), a letter to each boxholder, a message on KBRW.

Fred and Albert asked what were the best times for bigger and more representative meetings. The 7:00pm timeframe

seemed good, but they did want the meeting announced and posted 3 weeks before we came.

A big issue was the fact that the observers on the seismic boats are handpicked by the AEWG in Barrow and then referred to Western Geo. and LGL. It upset the people in Nuiqsut that Barrow people were chosen to monitor in Nuiqsut's traditional areas and that these monitors did not even have the courtesy to come to the village and talk to them about the monitoring. They want a local person as a part of the monitoring effort for seismic, and they want an Inupiat observer on BWASP. The points of contact for identifying these people are Leonard Lampe and the Village Coordinator.

When Fred and Paul kept asking for further concerns, the elders said that it was hard for them to voice concerns when other elders and tribal council members were not present. Albert asked when was a good time to meet with elders and the people said the elders were usually together on Thanksgiving and we could get a lot of concerns then.

Ruth N. was concerned about effects on the food fish eat, and observed that she had seen many of these meetings, and it was always the same thing [i.e., We are not heard.]. Paul again asked for more concerns and Ruth spoke about subsistence: We can buy food from the store but we prefer subsistence foods. She has fished every year and she believes the fishing is going to be affected by Alpine and Kalubik. She can tell a contaminated fish and has already caught some. They have been contaminated by the spill of drilling mud under the Colville River. There are red dots/punctures all over the fish, and it comes from contamination from drilling muds spilled in the Colville. They used to catch 150 fish a day, and now they get 9. She grew up hunting and fished as a girl and she still hunts today. She remembers once when a girl washed dishes in the river and the fish disappeared from that spot. She believes contamination is happening to the caribou as well. Caribou smell the Alpine smoke [air pollution] and scatter. Caribou are known for smelling humans and going the other direction.

Basically, the biggest concern from the elders present was that we come back and get more concerns when more elders are present. Albert asked if they would like to see our notes from the meeting, to see what we got and if we got it accurately. He asked if they would you like to see a summary of what we did so they could discuss it with the other elders? He asked the group if it would be helpful to have it in English and Inupiat?

Ruth N., Alice Apalook, and Marjorie Ahnupkana said the best thing to do would be to attend the elder potluck that happens once a month. All the elders would be there and we could bring the summary and maps, pass them around, have some food, and ask them for concerns then. They said we could coordinate this through Village Coordinator, Carolyn Ahkiviana. They felt that in such a setting we would get

plenty of concerns and more knowledge of the land and resources.

Marjorie A. and Ruth N. talked about how the Eskimo traditions of long ago were going away with the oil companies coming in. They were losing their old hunting grounds and have noticed fewer caribou. Caribou have changed their routes since the Alpine pipeline. They used to go from Fish Creek to Ocean Point, and on the way, cross the river near the village. Now, to avoid the Alpine drill site and pipeline, they go around to the east avoiding the village in the process. Part of the problem is that caribou won't put their antlers down to cross under a pipeline. They will go around it instead. It takes years for them to be willing to cross under. Also, 5 feet is too low for a pipeline with wintertime snow drift. Before the pipeline, we had the Porcupine Herd going to Fish Creek. Now there are going way out. There are very few caribou. It could be that they are afraid of the muskox. Paul asked if the muskox and the caribou were natural enemies and the reply was they must be. Over on the Itkillik River, the muskox chase the caribou and the elders don't like it.

In light of Mayor Lampe's comments earlier in the day, Paul and Fred asked if burying the pipeline or raising it would solve some of these problems. There was no consensus. Some people said the caribou would go under if it were higher and some said burying it was better. Ruth N. and Marjorie A. wanted to know what were the results of recent caribou studies. Does the FWS know these answers? They knew BP did some caribou studies at Badami but they never heard what the results were. Paul and Fred said they'd check on these studies and get back to the village.

Ruth N. said again that more elders needed to comment on these issues and that we should come for the potluck. The meeting adjourned about 9:30pm.

After the meeting, Frederick Tuke said his family had been in the area for 5 generations. He told us that Abraham Woods was an elder we should talk to and that he (Frederick) would like to be considered as a translator for future meetings.

D. KAKTOVIK

Nov. 5, 1999,

7:00pm at the Kaktovik Community Center

MMS Attendees were: Fred King, Albert Barros, Dave Roby, and Mike Burwell

Attendees: Susie Akootchook, Tom Cook, BP, Isaac Akootchook, Ida Angasan, Herman Aishanna, Vice-mayor, M. Aishanna, Merylin Traynor, Clarice Akootchook, Leonard Gordon

The meeting opened with an invocation by elder Isaac Akootchook in Inupiat. Then our translator Clarice Akootchook asked if we needed to translate the whole

meeting and the consensus was that people would ask her to translate as needed; the meeting was conducted in English.

Fred introduced the MMS team as well as the BP folks present: Tom Cook, and two other BP people, Erin Ford and Tom Reddin, running a United Way outreach to the village. Fred went through his PowerPoint presentation, with questions raised and answers given along the way.

Clarice Akootchook asked about job opportunities with Liberty, and Tom C. said there were some ongoing job program joint ventures with ASRC and that he would have Cindy Bailey send the details to her and Lon Sonsalla. Ida Angasan said that the local kids really needed job training.

Susie Akootchook asked for more information on the Boulder Patch, and Fred and Mike explained a bit about the Boulder Patch area. She said she didn't like any pipeline routing that would go through the area.

Isaac Akootchook asked about where permafrost was; Fred said there was none under the island site or the pipeline route but from the shoreline out 500 feet there was. Isaac talked about Foggy Island Bay, saying he had seen lots of rough water, wind, and waves there. He said these forces needed to be studied. He asked about gravel bags, and Fred and Tom C. told him that there would be cement armoring to above the waterline. Tom said this type of armoring had been used in Endicott and since 1986, they had never had to do maintenance on it. Tom assured those at the meeting that BP would be back to explain Liberty Island construction in more depth. Tom seemed to be saying that the use of gravel bags was over and that Liberty would follow Northstar in this regard.

Herman Aishanna wondered who was getting environmental impact funds. Fred replied that, as yet, there was no legislation for impact assistance. Fred and Mike explained the various impact assistance bills on the Hill.

Merylin Traynor asked what would happen if the island were moved south. Fred explained that the whole taxation regime would change but that the royalty arrangement would stay the same. Dave R. explained that it was the location of the oil reservoir that determined jurisdiction.

Susie A. asked about the foundation for the pipeline and Fred and Dave explained the undersea cross section and the onshore configuration. Merylin asked for clarification about two lines running from the island and Fred explained their would be oil and gas lines running together.

Merylin asked what the currents in the area were like. Fred said they were low but, offhand, he didn't know how fast they ran. He told her they would be trenching the route for the pipeline in winter when currents would be minimal and sedimentation less. Merylin also asked if there would be polar bears and seals in the vicinity of construction and Fred said that, yes, there were, and it was possible they would be disturbed. Mike talked about disturbance strategy plans that

were required to be in place and Fred stressed that winter construction would limit disturbance.

Susie A. wondered how big the island was going to be; Fred told her it would be about the size of three football fields. She wondered about noise and Fred said there would be two types, construction noise and production noise. Mike explained that noise from the island would hit the Barrier Islands first and disperse before it reached the areas of whale migration. She said that "noise underwater goes an long way," and Fred said noise would be discussed at length in the DEIS.

Herman A. said that he would like to see us "deviate those wells into State waters." He asked about trenching depth and Fred said it would be 8 feet deep with 7 feet of cover and that there was an alternative to bury it 15 feet. Herman observed: "I bet AEWG doesn't like this project." Fred said that yes, they were opposed to offshore development. Herman said with all the acreage in ANWR that the government should develop there before they go offshore. Fred said many people would like to do that, but at this time there's no development allowed.

Merlyn T. asked for more on the islands specifications and Fred showed his slide of the island in cross section. He talked some about the location and function of concrete mats and gravel bags and the steel sheet pile alternative. Tom C. told her that Northstar went away from using gravel bags and that the engineers for Liberty should be aware this may need to be changed for the Liberty island, as well. Dave explained that the island was 140 feet wider than the work surface on all sides.

Ida Angasan asked about the BP/State flap over BP's filing with the FTC. Dave R. explained that a proposed agreement had just been announced today.

Herman A. asked about the expected lifespan of the island, and Fred said it was 20 years. Herman asked if the bags would stay for 20 years and Fred told him yes. Herman asked about the shutdown of production at Badami. Tom C. said the wells weren't producing like expected. Ida A. said they'd laid off 150 people and Dave R. explained that the field would be shut in for this winter. Susie added that it was because the oil was too thick, and they were afraid it would freeze. Fred explained that Liberty oil was more like Endicott oil.

Merylin T. asked what would be left behind when the island was abandoned. Fred said that BP had to provide MMS with and environmental plan for island abandonment. Dave R. explained that, normally, they would have to remove all surface facilities. It could be decided to leave the island—it might at that point be potentially valuable habitat. The wells, of course, will be plugged and abandoned in accordance with MMS regulations.

Herman A. stated that the State got 27% of all revenue/royalties, but that the NSB would not get anything. In terms of Liberty, "they can't even tax it."

Isaac A. said the project should not be done because there were lots of waves, lots of rough water, but *not* really lots of ice pile up in the lagoons. It was not like around Barrow or Oliktok although he does remember this ice being picked up and deposited ashore by wave action that accompanied the 1964 Earthquake.

Clarice A. remembers a time when there was a sick polar bear in the village and they didn't know at the time who to call. Fred said he would provide her with a FWS contact.

The meeting ended with a brief talk by BP's United Way team saying there were there to see what they could do to help the village. Herman A. said "United Way. Welcome!."

E. ANCHORAGE

November 9, 1999, 7:00-9:00 pm

November 10, 1999, 12:00-5:00 pm

MMS, Alaska OCS Region

Third Floor Conference Room

MMS Attendees for both meetings were:

Paul Stang, 271-6045

Fred King, 271-6696

Dave Roby. 271-6557

Attendees on November 9:

Kristen Nelson, 564-5490, PNA, 2613 McRae Rd,
Anchorage, AK 99517

Ed LaFehr, 868-3592, BP Exploration, P.O. Box 196612,
Anchorage, AK 99519

Moon Lew, 564-4530, BP Exploration, P.O. Box 196612,
Anchorage, AK 99519

Karen Wuestenfeld, 564-5490, BP Exploration, P.O. Box
196612, Anchorage, AK 99519

Glen Gray, P.O. Box 33646, Juneau, AK

Pam Miller, 279-1909, P.O. Box 101811, Anchorage, AK
99510-1811

Emerson Milenski, 564-5362, BP Exploration, P.O. Box
196612, Anchorage, AK 99519

Dan Ritzman, 277-8234, Greenpeace

Melanie Duchin, 277-8234, Greenpeace

Michael Foster, 696-6200, Michael L. Foster & Associates

Attendees on November 10:

Moon Lew, 564-4530, BP Exploration, P.O. Box 196612,
Anchorage, AK 99519

Karen Wuestenfeld, 564-5490, BP Exploration, P.O. Box
196612, Anchorage, AK 99519

Katie Farley, 271-4476, SPCO/ADNR

Walt Johnson, 703-450-7956, MMS, Herndon

Melanie Duchin said that the MMS pipeline workshop indicated that directional drilling technology could extend to approximately 7 miles. MMS should consider and evaluate in the EIS developing the Liberty Prospect from onshore. The EIS should provide additional information about directional drilling.

She said that there are still concerns about climate change. The EIS section on cumulative impacts should include reasonable and foreseeable impacts.

She said that the cumulative effects analysis should also analyze the combined effects of Northstar and Liberty and future offshore developments. The analysis should evaluate the cumulative effects of such things as supply flight routes that travel in a loop from one production island to another and so forth. Also, MMS should indicate in the EIS what happens when the weather doesn't allow for such flights. The analysis should indicate the number of days per year of flights and the consequent impacts of the Liberty project on the whales if you can't fly above 1500 feet.

The EIS should do original analysis and not just reference Northstar or past MMS EIS's.

Pam Miller endorsed Melanie's comments and asked that we do a separate alternative in the EIS on directional drilling, especially if we are considering a 4-mile alternative. She also said that monitoring plans (both MMS's and BP's) programs should be part of the EIS. She felt that BP being on the ANIMIDA panel is an outrage. She wants a better definition of where the Boulder Patch is, as well as species distribution and composition.

The EIS should identify the biological species that are inhabiting the areas. Pam Miller stated that she is against the potential alternative route through the Boulder Patch to the Endicott Satellite Drilling Island. She also stated that it would be a waste of taxpayer's money to even consider such an outrageous alternative.

There are too many impacts associated with causeways to consider even a short causeway in the nearshore permafrost zone. She said MMS should require BP to submit a new C-plan (Oil Spill Contingency Plan) and it should be evaluated in the EIS. BPXA representatives indicated that they did submit a revised plan in June of this year. MMS should evaluate island locations that are in shallower water where oil cleanup may be more difficult because the shallow water depth may prevent some vessels from operating. The MMS study for North Slope oil spills should look at all sizes of spills. They have concerns about all oil spills, including small chronic spills.

Dan Ritzman said that watching the C-Plan trials made him even more worried about clean-up capability. He also suggested that if MMS considers an Endicott route for the pipeline, we need to describe costs of the monitoring program.

APPENDIX F

MMS-SPONSORED ENVIRONMENTAL STUDIES

This appendix was published as part of the Liberty Development and Production Plan (DPP) Draft Environmental Impact Statement (EIS) and was not revised for the Final EIS. The reader is referred to this appendix in the Draft EIS. This appendix is also available on the CD-ROM (MMS 2002-019 CD) and on the Internet (<http://www.mms.gov/alaska/cproject/liberty>).

Appendix F

Ongoing MMS-Sponsored Environmental Studies Applicable to Beaufort Sea Planning Areas, March 15, 2000

Circulation, Thermohaline Structure, and Cross-Shelf Transport in the Alaskan Beaufort Sea

Background: Current, temperature, and salinity time series are largely unavailable for the Arctic Ocean, including the in the Alaskan Beaufort Sea. Forcing and time and space scales are hypothesized rather than identified and confirmed. There are high interannual differences in flow and coastal salinity, but insufficient data to decipher whether these differences are due to long term trends or just inherent variability. Although there is salinity, temperature, and other data available for the Arctic Ocean, there is only one full year of cross-shelf mooring data along the Alaskan Beaufort coast. Data from elsewhere in the Arctic Ocean indicate that the oceanographic state of the Arctic Ocean may have changed since the earlier study. This study will provide a second year of data.

Objectives: The objectives of this study are to:

- Determine the mean transport over the outer continental shelf and slope and the cross-shelf and vertical scales of the mean flow field.
- Determine the magnitudes of transport variability and the dominant temporal and spatial scales associated with this variability.
- Determine the relation between variations in temperature and salinity and variations in the flow field at time scales between the synoptic to the seasonal. Determine if changes in the baroclinic flow are consistent with changes in the cross-shelf density structure.
- Determine the cross-shelf fluxes of heat, salt, and momentum. Determine if these are related to instabilities (eddy generation mechanisms) of the alongshore flow.
- Determine the relationship between observed flow and density variations and the surface wind field.

- Compare the results obtained from the proposed field program with those collected in 1987/88 in prior MMS research, to determine whether recent large changes in the Arctic Ocean are also reflected in the Beaufort Sea.
- Combine this data set with other measurements recently acquired from around the Arctic Ocean to provide an updated synthesis that relates the Beaufort Sea to the large-scale circulation of the Arctic Ocean.

Status Summary: Six moorings with multiple currents meters were deployed along the Beaufort Continental Slope in summer 1998, and five of the moorings were recovered in summer 1999. The sixth mooring was not recovered because of harsh weather and its recovery is proposed for fall 2000.

Evaluation of Sub-Sea Physical Environmental Data for the Beaufort Sea OCS and Incorporation into a Geographic Information System (GIS) Database

Background: Biological habitats and potential archaeological sites in the Beaufort Sea are directly related to sea-floor morphology, substrate, and sediment cover; water depth; and the severity and cyclicity of dynamic physical processes. Recent exploration and development activities in the Beaufort Sea have highlighted the need for the careful interpretation, and in some cases, reinterpretation of shallow geological and high-resolution geophysical data in evaluating sea floor environmental conditions, biological habitats, potential archaeological sites, and critical pipeline routes for the distribution of oil and gas from OCS development activities. This study will be completed in the year 2001 and will be used in order to evaluate future exploration and development drilling and pipeline plans for the Beaufort Sea.

Objectives: The objective of this study is to develop an integrated seafloor characterization and data set for the

Beaufort Sea Outer Continental Shelf . All available high-resolution seismic data and shallow subsurface geologic data from various site-specific surveys data is to be identified and compiled. The data will be interpreted and quantified in appropriate formats to describe environmental features of the seafloor surface and shallow strata.

Analytical tools and manuals will be developed for use by analysts.

Status Summary: The award for this contract was signed on June 30, 1999. The contract calls for a two-year study. The contractor is in the first year of data compilation and database design.

Synthesis and Collection of Meteorological Data in the Nearshore Beaufort Sea

Background: Near future development in the Alaska OCS will be in the nearshore region of the Beaufort Sea. We know from Kozo's research in the 1970's and 1980's that the upper air pressure fields on which modeled wind fields used in Arctic regional circulation models are based give increasing inaccurate results for surface winds within 20-30 kilometers of the Beaufort Sea coast. In OCS areas off the contiguous 48 States and in the Bering Sea, MMS has established a network of meteorological buoys to monitor the lower atmosphere over long periods (10 years). Existing public domain datasets for the Beaufort nearshore are limited and with time series in terms of months, too short to provide sufficient time series for use in MMS models, such as COZOIL, the MMS oil weathering model, or the nearshore circulation model proposed within this strategic plan. Recent CMI studies comparing simulated winds from different Arctic and hemispheric wind models to Pt. Barrow winds are not relevant to this study. This is because along the Beaufort Sea coast towards the east, orographic and sea breeze effects are too great.

Objectives: The objectives of this study are to collate and collect meteorological data in Beaufort Sea locations subject to immediate development. This study will develop a wind time series for sensitivity testing of MMS's nearshore and general regional circulation and trajectory models for the Beaufort Sea.

Status Summary: This study is in procurement phases. An RFP is planned to be issued this Fiscal Year.

Beaufort Sea Nearshore Under-Ice Currents: Science, Analysis, and Logistics

Background: Understanding the underice currents is a necessary precursor to estimating potential effects on sensitive resources from oil spills or in the landfast ice zone, and in particular at the Liberty and Northstar projects. The one study of underice currents by MMS (in 1978)

indicated that underice oil spills could pose risk to off-site, and in particular, shoreward resources. An important question is whether the underice currents could transport suspended sediments from the project area to the nearby Boulder Patch, and endanger kelp during critical underice growth period.

The 1978 study found that average currents under landfast ice appeared to be related to brine drainage and peak currents to negative surges, with neither related to the regional circulation pattern. The study was unable to measure currents directly under the ice, but instead calculated them from mass-balance considerations to average of 6 centimeters per second (cm/s) and to peak up to 37 cm/s towards the coast. Depending on the shallowness of the unmeasured pycnocline, these currents may have been faster. Underice current speed and direction are important because currents of 10-20 cm/s will move spilled oil along the underside of the ice.

Objectives: The objectives of this study are to:

- Measure currents, temperature, and salinity hourly at three locations in the landfast ice zone in the vicinities of Northstar and Liberty prospects.
- Quantify the magnitude of current variability and to describe the relationship between currents and local winds.
- Determine the vertical structure of the currents throughout the water column and how the structure changes with the development of the landfast ice through the winter and in summer when the ice melts and rivers flood the inner shelf.

Status Summary: Bottom mounted Doppler current meters were deployed at three sites in the Northstar/Liberty area in August 1999. These meters will be recovered in August 2000 and will provide vertical current profiles for that period. These will be the first long-term winter current profiles obtained in the nearshore Beaufort Sea.

Beaufort Sea and Chukchi Sea Seasonal Variability for Two Arctic Climate States

Background: Proshutinsky and Johnson (1997) recently showed evidence for the existence of two regimes or climate states for arctic atmosphere-ice-ocean circulation. Wind-driven motion in the Arctic was found to alternate between anticyclonic and cyclonic circulation with each regime persisting for 5-7 years, based on analysis of modeled sea level and ice motion. Anticyclonic wind-driven motion in the Arctic and Beaufort Sea appeared during 1946-1952, 1958-1962, 1972-1979, and 1984-1988. Cyclonic motion appeared during 1953-1957, 1963-1971, 1980-1983, and 1989-1997. The two climate states should differ in ice cover, ice thickness and drift, circulation (including reversal of the Beaufort gyre), ocean temperature and salinity, heat fluxes, wind speed, atmospheric pressure, cloudiness, and

precipitation and runoff. Confirmation of significant climate state differences has strong implications for both circulation and oil spill modeling in the Arctic

Objectives: The objectives of this study are to:

- Compare temporal and spatial variability of environmental fields at seasonal and interannual time scales.
- Compare circulation and ice drift data for the two climate states.
- Compare differences between ice cover for the two climate states.
- Compare differences in 3D temperature and salinity distributions for the two climate states.

Status Summary: This study is in the early steps of looking at how environmental parameters over the last 50 years; such seasonal ice thickness, ice concentration, sea temperature, wind speed, etc., have varied between the two multi-year climate states of Arctic atmosphere-ice-ocean circulation.

Revision of the OCS Oil-Weathering Model: Phases II and III

Background: This study will follow the recommendations made in the recently completed study “Revision of the OCS Oil-Weathering Model: Evaluation.” The OCS Oil-Weathering Model (OWM) has been used as a major analytical tool in every Alaska OCS EIS since the model was developed in 1983. The algorithms used in the model date from the late 1970’s and early 1980’s. The primary findings from the Sintef study were that the existing MMS model was difficult to use because of antiquated code, that it was likely to produce erroneous results for many crudes, and that its algorithms needed to be updated or replaced with ones that incorporated the past two decades and a half of oil spill research. The primary recommendation was that rather than updating algorithms and code in the MMS model, MMS would find it more cost-effective for MMS to utilize an existing state-of-the-art OWM.

Objectives: The objectives of this study are to obtain an existing state-of-the-art OWM for MMS use and to upgrade the model to meet MMS needs.

Status Summary: We have obtained a DOI-wide license for Sintef’s Oil Weathering Model. Sintef is making additional improvements to the model for MMS, including addition of more Alaskan oils to the model data base.

Update of Circulation and Oil-Spill-Trajectory Model for Beaufort Sea Nearshore Development Areas

Background: Since 1991, the MMS has been funding work on the adaptation of the SPEM model to the Alaskan Arctic coastal region. The SPEM originally stood for Semi-Spectral Primitive Equation Model, but the current 5.1 version of SPEM retains the acronym while no longer using a spectral component. The SPEM has the advantage of being a public-domain model with an international scientific users’ group that has been making improvements in the model beyond those contracted for by MMS. The MMS is currently funding Rutgers University to implement a curvilinear grid to enhance SPEM resolution and to execute a 10-year simulation using historical data. SPEM should provide needed information for MMS’s assessments for regional oil and gas lease sales. However, SPEM is unable to resolve the small barrier islands and ocean circulation within the first 10-20 kilometers beyond the State 3-mile line, where Federal OCS development is accelerating.

This study will build on the recommendations and results from multi year simulations of Arctic circulation using the SPEM 5.1 model in an FY 1996-1999 study, recently completed CMI Arctic 2-D and 1.5-D modeling experiments, and additional Chukchi and Beaufort Sea circulation data derived from ongoing CMI and international Arctic oceanographic studies. The MMS and other current ice models are based on ice physics, which cannot be reliably scaled down to the approximately 1-km grid scale useful to resolve OCS leasing issues or to the finer scales needed postlease to evaluate specific development issues. However, improved ice algorithms are currently being developed in Navy-sponsored research for the necessary scale. The wind fields available for the current modeling effort do not have accurate corrections for nearshore sea-breeze or orographic effects. Winds near Barrow are correctly depicted in the data, but winds farther south along the Chukchi Sea coast or eastward along the Beaufort Sea coast are known to be wrong in magnitude and direction, out to 20 or more kilometers. This is about as far offshore as current oil industry interest extends in the Beaufort Sea.

Objectives: The objective of this study is to obtain a finer resolution model to simulate circulation in the nearshore Beaufort Sea, with emphasis on the first 25 kilometers beyond land between the Colville River and Canning Rivers. The model will be designed to provide the information for the MMS oil spill trajectory model and will also provide surface circulation fields that can be used to drive the MMS COZOIL model.

Status Summary: This study is in procurement phases. An RFP is planned to be issued this Fiscal Year.

Environmental Sensitivity Index Shoreline Classification in the Beaufort Sea

Background: Industry and State and Federal Agencies including MMS form the Alaska North Slope Task Force. Of this group Industry, NOAA and the USCG are funding the compilation of Industry's Environmental Sensitivity Index (ESI) shoreline classification and biological data from the Colville River to the Canning River.

The ESI shoreline classification contains water and land features, rivers and streams, source codes and Environmental Sensitivity Index classification for shoreline. These data are needed for use in the MMS Corporate Environmental Database and for computer analysis using ArcView. The MMS Coastal and Offshore Resource Information System (CORIS) database specifications, part of the MMS corporate Technical Information Management System (TIMS) database, are designed to provide an authoritative database for environmental analysis in MMS. With the use of peripheral programs, analysts will be able quickly to identify resources at risk and run analytical routines to determine potential impacts. Currently the oil industry has mapped ESI types from the Colville River to the Canning River. NOAA has published at a scale of 1:250,000 a set of four maps (NOAA 1999, *North Slope, Alaska: Environmentally Sensitive Areas*, Seattle: Hazardous Materials Response Division, National Oceanic and Atmospheric Administration, 4 maps) which are partially based upon these data and show the mapping of "Sensitive Shoreline Habitats" between the Colville and the Canning Rivers. Data on ESI shoreline types for the Beaufort Sea from Barrow to the Colville River and from the Canning River to the Canadian Border are more than 20 years old and are very generalized. They are not compatible with the precision required for the CORIS data structure and are not in a digital format.

Objectives: The primary objective of this study is to obtain an updated ESI shoreline data set for use in ArcView/Arc Info. The ESI shoreline data set will also be used in analysis of oil spill prevention plans and to facilitate faster and more accurate environmental analysis in the Beaufort Sea environmental impact statements and environmental assessments.

Status Summary: A contract for this study was awarded in August, 2000. Field work should be done in June or July, 2001.

Kinetics and Mechanisms of Slow PAH Desorption from Lower Cook Inlet and Beaufort Sea Sediments

Background: Adsorption to sediment particles is a key process in determining the transport and fate of polycyclic aromatic hydrocarbons (PAH) in the marine environment.

Previous CMI-funded studies of lower Cook Inlet sediments have shown that a substantial part of PAH adsorption is not rapidly reversible. Further study is needed to develop the ability to predict how adsorption and desorption would affect the longer term persistence (and toxicity) of PAH contamination in Alaska marine sediments. Recent *Exxon Valdez* studies have shown that the residual PAH concentrations in contaminated sediments are more toxic at much lower concentrations than previously estimated.

Objectives: The objectives of this study are to test the hypotheses:

- PAH adsorption found apparently irreversible in earlier CMI experiments is reversible with longer reaction times or greater water:particle ratios.
- Interactions of PAH with sediment organic matter are responsible for adsorption that appears to be irreversible.
- The properties of sediment organic matter govern adsorption and desorption of PAH by marine sediments.

Status Summary: Humic acids have been extracted from Beaufort Sea and Cook Inlet sediments. The humic acids are being chemically characterized. Subsequent experiments will establish the kinetics of PAH sorption on to these humics.

Petroleum Hydrocarbon Degrading Communities in Beaufort Sea Sediments

Background: High latitude marine oil spills have demonstrated that the composition of microbial communities affects rates of hydrocarbon degradation. Prior MMS research in the Beaufort Sea in the late 1970's and early 1980's indicated that indigenous microbes in this environment were poorly suited for rapid hydrocarbon destruction. Little research has been performed on Beaufort hydrocarbon degraders since then, and little is known about whether sediment microbes have acclimated to hydrocarbon inputs in the last 20 years.

Objectives: The objectives of this study are to:

- Evaluate the current degree of microbial community acclimation to hydrocarbons from Barrow to the Prudhoe Bay/Northstar/Liberty area.
- Evaluate the effects of fine-grained Beaufort Sea sediments on rates of community acclimation.
- Evaluate how Beaufort Sea sediments might affect bioavailability of petroleum to communities of acclimated microbes.

Status Summary: The first year of this study collected samples from 15 sites near Barrow. The samples were analyzed for present numbers and activity of microbes, and are being used for experiments on petroleum hydrocarbon degradation. The study will move to the central Beaufort nearshore in the second year.

The Role of Zooplankton in the Distribution of Hydrocarbons

Background: Copepods play an important role in carbon flux in marine ecosystems. Vertical transport of carbon from the euphotic surface water to the benthos occurs when copepods feed on diatoms and incorporate them into larger, negatively buoyant fecal pellets. Therefore, analysis of hydrocarbon content of fecal pellets would provide insights in understanding the role of copepods in distribution and remediation of hydrocarbons. Data derived from analysis of copepod fecal pellets will provide baseline information for experimentation and modeling of ecosystem processes, which include accumulation of hydrocarbons in higher trophic levels such as commercial fish species.

Objectives: The objectives of this study are to determine the role of copepods in the distribution and bioremediation of hydrocarbons in the environment. Specifically, this study will:

- Determine the composition and seasonal variation of lipids in forage plankton in Prince William Sound.
- Determine the relationships between lipid content and lipid composition in forage plankton and patterns of accumulation of hydrocarbons in copepod body tissue.
- Determine the role of the copepods *Neocalanus* spp. and *Pseudocalanus* spp. in the distribution of mineral hydrocarbons in the environment.

Status Summary: Preliminary experiments to culture zooplankton have been successful. Progress has been made on the sampling design. Fieldwork will begin this summer.

Historical Changes in Trace-Metal and Hydrocarbon Contaminants on the Inner Shelf, Beaufort Sea: Prior and Subsequent to Petroleum-Related Industrial Developments

Background: In the 1970's, MMS funded the University of Alaska to conduct nearshore, inner shelf, contaminant studies in sediments of the Beaufort Sea, under the Outer Continental Shelf Environmental Assessment Program. MMS also initiated a regional monitoring program in the Beaufort Sea in 1984 designed to detect and quantify long-term changes in the concentrations of metals and hydrocarbons in sediments and animal tissues.

Objectives: The objectives of this study are to determine historical changes in the accumulation of Cu, Cr, Ni, V, Pb, Zn, Ba, Cd, methyl mercury, and selected petroleum hydrocarbons in nearshore sediments of the Beaufort Sea, in the vicinity of proposed or ongoing development.

Status Summary: A preliminary draft report has been received and reviewed by MMS. An edited draft Final Report is due for review.

Seabird Samples as Resources for Marine Environmental Assessment

Background: The birds of Alaska that are dependent upon marine environments comprise a complex array of more than 100 species occupying three trophic levels. These birds are a major component of Alaska's marine ecosystems and are vulnerable to both natural and anthropogenic changes (e.g., Outer Continental Shelf activities). Many species provide an important source of food for humans, and more generally, are heavily used for a variety of subsistence purposes by Alaskan natives. If analyses contrasting places or events are to be used to monitor the environment and biological systems, archival samples must be routinely preserved. Birds are excellent environmental indicators, and can be thought of as small biological filters sampling various aspects of marine ecosystems, and thus represent a useful model for such analyses. Further, many avian species are protected by various U. S. Laws and international treaties.

Objectives: The objectives of this study are to:

- Preserve and make available to the research community a substantially increased number of high-quality samples from marine and coastal birds in Alaska.
- Make samples available to the research community for studies ranging from contaminants and stable isotopes to genetics and morphology.

Status Summary: A Ph.D. student has been recruited to the project. Collaborations with various field investigations have been established. Samples have been obtained from Barrow and Cook Inlet.

Monitoring Beaufort Sea Waterfowl and Marine Birds

Background: Oldsquaw, eiders, and other waterbirds feed, molt, stage and/or migrate in various Beaufort Sea marine habitats. Recent data show that threatened spectacled eiders, as well as other species of concern, stage in nearshore and offshore Beaufort Sea waters. An existing protocol, entitled "Design and Testing of a Monitoring Program for Beaufort Sea Waterfowl and Marine Birds" (OCS Study MMS 92-0060), was developed and tested in the Beaufort Sea area that includes the Northstar, Sandpiper, and Liberty Units. This study covers the areas and species most likely to be affected by activities associated with oil and gas development in these units.

Objectives: The overall goal of this study is to monitor the effects of potentially disturbing activities associated with oil and gas development on the distribution and abundance of waterfowl and other waterbirds using marine habitats in the east-central Beaufort Sea. Specific objectives are to:

- ❖ Use an existing protocol (Johnson and Gazey, 1992) to monitor numbers of Oldsquaw and other species in

industrial and *control* areas defined by these investigators.

- Perform replicate aerial surveys along previously established transects in a manner that will allow comparison with the earlier results.
- Expand the survey to include nearshore areas between the original *industrial* (Jones-Return Islands) and *control* (Stockton-Maguire-Flaxman Islands) areas.
- Define the range of variation for area waterfowl and marine bird populations, and correlate with environmental factors and oil and gas development activities.
- ❖ Expand aerial monitoring about 50 km offshore to determine the extent of use of this habitat by eiders, in particular, where they would be vulnerable to oil spills originating in the Northstar and Liberty Units; determine if the use of specific areas is predictable.
- ❖ Develop a monitoring protocol to determine distribution and abundance of Common Eiders breeding on barrier islands.
- ❖ Investigate potential effects of disturbance on Oldsquaw and Common Eider annual cycle parameters that could cause changes in their distribution and abundance.
- ❖ Compare the results with historical data to detect trends; coordinate with ongoing studies and incorporate pertinent interpretation of their findings into the final report.
- ❖ Recommend cost-effective and feasible options for future monitoring.

Status Summary: The first field season has been completed. A series of aircraft surveys of waterfowl in offshore habitat was completed and behavioral observations were undertaken. The first annual report has been submitted.

Monitoring the Distribution of Arctic Whales

Background: The MMS has conducted aerial surveys of the fall migration of bowhead whales each year since 1987. Methods are comparable from year to year, based on similar monitoring dating to 1979. Real-time data are used to implement overall seasonal restrictions and limitations on geological and geophysical exploration. The study provides the only long-term database for evaluating potential cumulative effects of oil- and gas-exploration activities on the entire bowhead-migration corridor across the Alaskan Beaufort Sea. Project reports compare distances from shore and the water depths used by migrating bowheads. Data are collected in a robust GIS-compatible data structure.

Objectives: The primary goals of the project are to:

- Provide real-time data to MMS and the National Marine Fisheries Service (NMFS) on the general progress of

the fall migration of bowhead whales across the Alaskan Beaufort Sea.

- Monitor temporal and spatial trends in the distribution, relative abundance, habitat, and behaviors (e.g., feeding) of endangered whales in arctic waters.
- Define and analyze for significant interyear differences and long-term trends in the distance from shore and the water depth at which whales migrate.
- Provide an objective area-wide context for management interpretation of the overall fall migration of bowhead whales and site-specific study results.

Status Summary: The Project Manager is continuing work on the FY 1998-FY 1999 Draft Final Report.

Alaskan Marine Mammal Tissues Archival Project

Background: Alaskan Natives use many marine mammal species for subsistence and thus are concerned about possible contamination from OCS-related discharges. Also, chemical pollution can have adverse effects on marine mammals. The collection of marine mammal tissues over a period of years allows for determination of baseline contaminant loads for comparisons with levels in specimens associated with oil spills or in the vicinity of drilling operations. Since adding a part-time USGS-BRD Biological Technician to the Project, the number of samples collected has increased. The project also has linkages with NOAA, a lead agency for AEPS/AMAP. Tissues collected so far have come from Barrow, Point Lay, Point Hope, Nome, St. Paul Island, English Bay, Cook Inlet, Prince William Sound, the Aleutian Islands, St. Lawrence Island, and Round Island. Marine mammals species sampled so far include ringed seals, bearded seals, beluga whales, bowhead whales, spotted seals, harbor seals, Steller sea lions, northern fur seals, Pacific walrus, and polar bears. Aliquots have been analyzed from a representative number of these samples.

Objectives: The objectives of this study are to:

- Collect tissues from Alaskan marine mammals for long-term cryogenic archival.
- Determine and monitor levels of heavy metals, PAH's, and other contaminants associated with the oil and gas industry in marine mammals, with special emphasis on subsistence resources.
- Monitor the condition of archived samples over time.
- Develop new parameters and indices to describe contaminant burdens.
- Relate contaminant burdens to human-health-risk assessment.

Status Summary: Tissues from Alaskan marine mammals continue to be collected and archived cryogenically for hydrocarbon and heavy metal analysis.

The Alaskan Frozen-Tissue Collection and Associated Electronic Database: A Resource for Marine Biotechnology

Background: The Alaska Frozen Tissue Collection (AFTC) collects animal tissues from a variety of species, thus addressing concerns of Alaskan Native subsistence hunters over possible contamination of food from various industrial sources. The AFTC has been collecting animal tissues for years, but it has been difficult to access the information on tissue analyses. The tissue inventory is fully computerized and, where available, shows latitudes and longitudes of collected specimens for potential GIS mapping.

Objectives: The objectives of this study are to:

- Expand the scope of the existing collection of tissues from marine mammals and other specimens of the Beaufort Sea, Cook Inlet, Shelikof Strait, and other planning areas.
- Develop an electronic database that is accessible through the Internet, thus facilitating the transfer of information and sharing genetic resources among tissue investigators.
- Ensure a long-term systematic record of frozen tissues from Alaska's marine ecosystems.

Status Summary: Tissues from marine mammal and other species continue to be collected and frozen. AFTC tissues are listed at:

<http://zorba.uafadm.alaska.edu/museum/af/index>.

Monitoring Key Marine Mammals: Arctic

Background: Ringed seals have been identified as a "keystone" species in the Arctic marine environment. They represent a top-level predator in the food chain and an abundant species that occurs on the OCS year-around. Their distribution is affected by operations, and their abundance probably could be affected by a substantial oil spill. During 1985-1987 a program conducted by the Alaska Department of Fish and Game (ADF&G), with support from the MMS, developed a formal protocol for aerial surveys to monitor the distribution and abundance of ringed seals off the coast of northern Alaska. Using this protocol, ringed seal surveys were conducted during 1985, 1986, and 1987 along the Beaufort Sea coast. The 1989 monitoring report described their typical abundance and noted the range of natural variation. Since then, site-specific data have been collected during industry exploratory operations. All of this information was reviewed before additional monitoring surveys were conducted.

Objectives: The objectives of this study are to:

- Review and define the previously established protocol for monitoring ringed seals by aerial surveys.

- Estimate relative abundance and density of molting ringed seals on fast ice in the Beaufort Sea during 1996-1998 and compare these estimates with data collected during 1985-1987.
- Correlate ringed seal densities on fast ice with environmental parameters.
- Determine abundance and density of molting ringed seals at and near industrial operations, and compare these with otherwise comparable nonindustrial areas.
- Review adequacy of ringed seal data collected by past industry site-specific monitoring programs, and make recommendations for protocols to be used in future industry studies.
- Provide reports of findings that result from ringed seal monitoring to local residents and subsistence users.

Status Summary: Ringed seals were counted along a series of aerial survey transects in June. With the completion of the fourth field season, all field work is now finished on this project. A final report is due in late March.

Bowhead Whale Feeding in the Eastern Alaskan Beaufort Sea: Update of Scientific and Traditional Information

Background: The extent to which the bowhead whale population utilizes OCS areas in the eastern Alaskan Beaufort Sea for feeding, as well as this area's importance to individual whales, is being studied to yield more definitive quantitative estimates. The study updates and improves on a major scientific report which estimated that the eastern Alaskan Beaufort Sea is not an important feeding habitat for bowhead whales.

Objectives: The objectives of this study are to:

- Collaboratively (with key stakeholders), design and conduct research appropriate for quantifying the importance of the eastern Alaskan Beaufort Sea as a feeding area for bowhead whales.
- Analyze the literature and other available sources, including traditional-knowledge sources, for previous years and, where possible, test the above hypotheses for those years.
- Update available information on disturbance to feeding bowhead whales.
- Characterize the ambient acoustic environment in the eastern Alaskan Beaufort Sea and predict sound levels of oil-and-gas-industry activity received by potentially feeding whales.

Status Summary: Three of four field seasons have been completed. Following the final field season (Fall 2000) an overall final report will be submitted.

Correction Factor for Ringed Seal Surveys in Northern Alaska

Background: A protocol for monitoring ringed seal distribution and relative densities in Arctic waters has already been developed for MMS and implemented over 6 field seasons during spring basking periods when the greatest number of seals are hauled out on the ice. This study will augment previous monitoring by permitting estimation of true ringed seal densities based on the number visible from an airplane. Good information exists on ringed seal ecology and distribution in industrial versus control areas, but not enough to estimate true densities correctly. Correction factors developed for harbor seals have been found to be applicable to other years, as long as they and the survey estimates were developed in the same areas at similar times of the year. Most aerial surveys for ringed seals have attempted to standardize to late May to early June and to mid-day. The correction factor will facilitate re-analysis of historical data collected in GIS-compatible formats.

Objectives: The goal of the study is to estimate a correction factor for the proportion of ringed seals not visible during aerial surveys and thereby, enhance the protocol for estimating Arctic ringed seal densities from aerial monitoring results. Useful quantitative information on ringed seal behavior will also be obtained, as identified in the methods section.

Status Summary: Two field seasons have been successfully completed. Telemetry data, including 4,961 hourly observations of the locations of radio-tagged seals, are being analyzed with on-site meteorological data from the same time period, to determine the environmental influences on haul-out behavior.

Polar Bear Den Surveys

Background: Two stocks of polar bear inhabit the Arctic OCS region. The Beaufort stock is shared with Canada and dens partly in the eastern Alaskan Beaufort Sea. Remote sensing of polar bear dens might be more reliable and safer than ground surveys. Aerial denning surveys would provide a measure of reproductive effort and success, and an index to population trends. Such surveys in prospective exploration areas could provide information for avoiding site-specific effects. A scientifically valid estimate of the Chukchi/Bering Sea population size is not currently available and current information on the population dynamics of the polar bear population is incomplete. The USGS-BRD, USFWS, and Russian scientists have conducted previous surveys of polar bear dens. Past survey efforts have been complicated by inconsistencies in survey methodologies, timing, and location and by the large variation in den estimates.

Objectives: The goal is to reliably identify subnivean polar bear dens along the North Slope of Alaska. Specific objectives are to:

Phase I

- Test forward-looking infrared (FLIR) imaging devices from aircraft near Prudhoe Bay, Alaska.
- Conduct a workshop to evaluate the effectiveness of FLIR imagery in detecting subnivean polar bear maternal dens.

Phase II (depending on the success of Phase I)

- Develop a valid repeatable aerial remote-sensing protocol for surveying polar bear dens.
- Use the protocol to identify polar bear denning sites along the eastern Alaskan Beaufort Sea and correlate with habitat features.

Status Summary: A workshop is planned for May, 2000 pending successful completion of field tests of Forward Looking Infra-Red (FLIR) technology for detecting polar bear dens.

Simulation Modeling of the Effects of Arctic Oil Spills on the Population Dynamics of Polar Bears

Background: The USGS-BRD maintains a large dataset on polar bear distribution in Arctic waters. The MMS has an arctic oil-spill trajectory model which is used each time there is a Beaufort Sea Environmental Impact Statement. The study would be coordinated as appropriate with MMS oil-spill modelers. A great deal is already known about the distribution and movements of polar bears in Alaska OCS Beaufort Sea planning areas through an ongoing program of satellite tagging and tracking conducted by USGS-BRD. The MMS already has an updateable oil-spill model for the Beaufort Sea. Information is also available on the potential effects of oil on individual polar bears.

Objectives: The goal is to predict the effects of hypothetical Beaufort Sea oil spills and other postulated mortality on the population recovery of polar bears. Specific objectives are to:

- Develop/refine an independent, conceptual, polar bear population-dynamics model for Alaskan waters, with assumptions and initial conditions that can respond to hypothetical removals. Conduct a sensitivity analysis of this model.
- Produce an interactive model compatible with MMS hardware and software standards at the time of completion and a users manual for testing revised data input and model assumptions as may be appropriate for future lease sales.

Status Summary: Data from polar bear locations, based on satellite telemetry, have been analyzed using BRD's polar

bear distribution/density model. The polar bear population dynamics model continues to be developed.

Exxon Valdez Oil Spill, Cleanup, and Litigation: A Community-Based Collection of Social-Impacts Information and Analysis, 1989-1996

Background: The oil spill from the *Exxon Valdez* grounding not only contaminated natural habitat and resources but also produced a cleanup effort that was a major causal agent for ongoing social impacts among communities in Southcentral Alaska. The effects from the oil spill, cleanup, and subsequent litigation have been documented variously in media coverage and by research initiated by MMS, the Alaska Conference of Mayors, the State of Alaska, Federal resource and response agencies, academic institutions, and individual researchers. The level of information regarding the changes in the human environment related to the *Exxon Valdez* oil spill, cleanup, and litigation is varied—without a comprehensive formal, comparative, quantitative, and qualitative analysis of existing data, this information is of limited use to decision makers.

Objectives: The objectives of this study are to:

- Collect, organize and synthesize all community-based social information associated with the *Exxon Valdez* oil spill, cleanup, and associated litigation for the period 1989—the year of the spill—through the date this contract was awarded that shows the effects on the human environment.
- Identify key social factors and analyze the literature by these factors showing effects resulting from the *Exxon Valdez* oil spill, cleanup, and litigation. The Contractor was required to solicit input and concurrence of the key social factors from representatives of MMS, the State of Alaska, local communities, and Native organizations.
- Prepare a CD-ROM, which is PC-based, containing an annotated bibliography, abstracts, social factors, analytical findings of this study, and source documents.

Status Summary: The main synthesis is completed with source documents available on CD-ROM and a hard copy final report. Additional reports will be added to the CD-ROM by September, 2000.

Collection of Traditional Knowledge of the Alaskan North Slope

Background: The Native people of Arctic Alaska have many years of experience in living in Arctic environments and have much knowledge on the biological and physical environment of both the marine and terrestrial ecosystems. Much of this knowledge has been passed on from one

generation to the next by word of mouth. Little of it is in published form and even less is indexed. Much traditional knowledge has, however, been written, audio-recorded, archived and, in some cases, published. This information has not been collected, indexed, or fully abstracted. Because of this, much traditional knowledge has not been readily available to the scientific community. Potential closure of the BIA ANCSA Office could leave the 8,000 interview files unavailable.

Objectives: The objectives of this study are to:

- Locate, collect and organize all “traditional-knowledge” information associated with the Alaska North Slope Borough (NSB), encompassing oral-history-taped interviews, written transcripts, published sources, and textual and video records including any CD-ROM “jukeboxes” produced for the North Slope Borough (NSB) by the Alaska Oral History Project at the University of Alaska-Fairbanks (UAF) of elder interviews and Elders’ Conferences and the Bureau of Indian Affairs (BIA) Alaska Native Claims Settlement Act (ANCSA) Office Native-allotment-interview files (8,000).
- Identify key traditional-knowledge indices for structuring and abstracting.
- Prepare a PC-based CD-ROM containing an annotated bibliography, abstracts, traditional-knowledge indices and findings of this study.
- Prepare an Inupiat epistemology.

Status Summary Approximately one third of the traditional knowledge sources have been added to the Annotated Bibliography. A draft Epistemology and list of key words have been prepared. The project is scheduled for completion in December, 2001.

Subsistence Economics And Oil Development: Case Studies From Nuiqsut And Kaktovik, Alaska

Results from an investigation focusing on evidence of harvest disruption effects from expanding oil and gas development on the mixed subsistence-cash economies of two northern Alaska Inupiat communities, Nuiqsut and Kaktovik, is presented. Systematic household and key respondent information collected by the Division of Subsistence, Alaska Department of Fish and Game, in 1985, 1986, 1992, 1993, and 1998 supplied the analytic basis of this effort.

Harvest effects from increasing industrialization on subsistence harvests were documented in the two communities through this study. Comparisons with similar data from SW Alaska communities indicate that variability in resource harvests between years is less strong in Nuiqsut and Kaktovik. Unsuccessful harvest of a major subsistence resource in Kaktovik in 1985, and harvest area displacement

in the Nuiqsut area in 1993 (and 1994), recorded in community harvest data sets, are events firmly connected to anthropogenic effects rather than seasonal or population variations as is the case SW Alaska community data sets.

Recent changes in timing of Nuiqsut bowhead whale harvest processing and transportation are documented as taking place due to industry safety concerns in the near-shore area of the mid-Beaufort Sea. Harvest and transportation regulations limiting subsistence hunting options in portions of the industrializing area and other, more subtle, subsistence harvest effects resulting from increasing industrial infrastructure, industry support activities, and personnel within traditional resource harvest areas of both Nuiqsut and Kaktovik will also be discussed.

We recommend steps be taken to devise improved ways for communities near industrial development on Alaska's North Slope to be meaningfully involved in land use planning and evaluation of proposed industry activities. In addition, long-term systematic monitoring, assessment, and evaluation of effectiveness of subsistence protection and mitigation measures now in common use must be undertaken. Finally, increased efforts by government and industry are needed to develop a functional understanding of cumulative impact effects on subsistence resources, harvester access, harvesting activities and productivity resulting from continuing industrialization in northern Alaska.

Publication of a Book/Synthesis on the Socioeconomic Effects of Oil and Gas Industry Activity on the Alaska OCS

Background: The Alaska OCS Region has implemented an important socioeconomic component of its overall Environmental Studies Program, resulting in the publication of more than 160 Technical Reports (TR's) addressing statewide socioeconomic study topics. Methodologies have included case studies, institutional profile analysis and analysis of secondary-source materials, modeling and econometrics analysis, and survey research. In recent years, socioeconomic studies have become more focused and issue-oriented, emphasizing the critical points between OCS development and social systems with which potential development would interact. For example, studies have collected time-series information and measures of community and regional well-being as bases for social-indicators monitoring.

Considering the extent of MMS's social research in Alaska and the substantial information accumulated, a workshop examining the usability of the current research in its original forms versus the costs and benefits of further synthesis was recently conducted. In planning for the preparation of a useful resource document resulting from the workshop efforts, the workshop participants identified a tentative outline, chapter integration, and potential co-sponsors.

The level of information regarding changes in the socioeconomic environment related to OCS activities is varied—without a comprehensive formal, comparative, quantitative, and qualitative documentation of existing data, this information is of limited use to decision makers.

Objectives: The objective of this study is to coordinate and prepare a peer-reviewed book/synthesis of available information about the potential socioeconomic effects of oil- and gas-industry activity on the Alaska OCS.

Status Summary: The prime contractor is working on author designations and is preparing a revised schedule for this project.

Update Oil Industry Labor Factors for Alaska Manpower Model

Background: The Manpower Model was created in the late 1970's and early 1980's to project the number of workers directly employed in proposed OCS exploration and development activities. This data is used in another model to predict secondary employment and population. The employment data from the Manpower Model and the secondary employment and population data are used in EIS's. The input factors to the Manpower Model were based on information, no more current than the early 1980's, from industry on the actual number of workers used for 20 different tasks and numerous subtasks through the full range of activity from exploration and development to production. Technology has changed sufficiently that the input variables to this model should be re-examined and adjusted. The employment and population projections in recent EIS's do not reflect current industry practices and technology. Information about current industry practices is best obtained from industry representatives and consultants to industry.

Objectives: The objective of this study is to update the Manpower Model with input variables that accurately reflect the number of workers needed to complete tasks associated with exploration, development, and production on the OCS.

Status Summary: The updated Manpower Model with linkages to the IMPLAN Model is scheduled for completion in April, 2000.

Regional Economic Impact Analysis of Subsistence Bowhead Whaling: Accounting for Non-Market Activities on Alaska's North Slope

Background: Subsistence activities by Inupiat of the North Slope including whaling are difficult for contemporary western researchers to evaluate or to quantify. Two economic theories, home production theory and regional, input-output modeling (IMPLAN) are appropriate for policy and resource development analysis in Alaska and analysis of

the economics of subsistence whale harvest. Using these two theories and gathering data to apply to the theories can help answer questions more precisely about the economics of subsistence whale harvest. Barrow, Nuiqsut, and Kaktovik are the primary communities where subsistence whale hunting is done that potentially could be impacted by OCS activities in the Beaufort Sea.

Objectives: The overall objective of this study is to provide community economic profiles and a working regional economic model for the communities of Barrow, Kaktovik, and Nuiqsut.

Status Summary: This three-year project is just starting. The first step of obtaining endorsement from the Barrow, Kaktovik and Nuiqsut communities is planned for an unspecified date after March , 2000.

Reference Manual and GIS Overlays of Oil-Industry and Other Human Activity (1970-1995) in the Beaufort Sea

Background: Analysis of the potential effects on wildlife of oil-industry and other human activities has been limited by the quality and resolution of data available on these activities. This study will provide wildlife scientists, Native organizations, and others with the authoritative historic information on human activity needed to analyze the potential effects of such activities on whale migrations, wildlife distributions, shipwrecks, etc.

Objectives: The objectives of this study are to:

- Quantify offshore drilling, seismic exploration, vessel- and helicopter-support activity in the Beaufort Sea in small units that are comparable between areas and years (e.g., line miles shot by area).
- Quantify other human activity in the Beaufort Sea such as number and types of commercial vessels, subsistence hunting, and aircraft on an annual basis, specifying when and where such human activity occurred.
- Compile measures for the above human activities in an interyear, cross-indexed reference manual and as ARC/INFO overlays—both useful for defining “industrial” versus control zones, in identifying between-year trends, and in comparing levels of various types of oil- industry activity with other human activities and wildlife distributions.

Status Summary: The study has completed the first year and half of data compilation on human activities from oil and gas operations within the Federal OCS in the Beaufort Sea. Consideration of revisions to scope and obtaining clearance for access to proprietary data has impacted progress.

ANIMIDA - Arctic Nearshore Impact Monitoring In Development Area

Background: Residents of the villages of Nuiqsut, Kaktovik and Barrow are particularly concerned about long term effects of offshore developments at Liberty and Northstar as well as long term effects of any development from Lease Sales 170 and 176. Interagency reviews of related EIS’s and Development and Production Plans recommend monitoring impacts of Northstar and Liberty. Current information on selected topics is available but likely to be out of date or not of sufficient geographic or seasonal focus to meet the needs of this effort.

This study gathers long term monitoring data which will provide a basis of continuity and consistency in evaluation of potential impacts from site-specific, upcoming development and production in the Beaufort Sea. Priority monitoring issues are being determined through public and interagency comment, and coordinated with lessees and other organizations.

Objectives: Due to the scale and scope of this study, the objectives are phased.

Objective 1 - Year 1/Phase 1: Environmental Baselines:

- Perform a brief and focused literature review for the Liberty and Northstar areas.
- Initiate baseline efforts on underwater noise and vibration, sediment quality, and resuspension/deposition.
- Coordinate the above baseline efforts with any ongoing or previous applicable MMS or industry site specific monitoring.

Objective 2 - Years 2-5/Phase 2: Integrated Physical, Chemical, Biological, and Subsistence Impact Monitoring in Nearshore Development Area:

- Detailed interdisciplinary monitoring objectives, with increased scope to include future key impact receptors will be identified by December, 1999 following available comments for Northstar and Liberty EIS’s. It is anticipated that specific living resource and socioeconomic components such as benthic/kelp communities, local vertebrate populations, and local subsistence harvest/use patterns will be included.
- Compile future monitoring results into statistical, graphical/mapped, and other formats of spatial, temporal, and pattern analysis useful to decision making and operational evaluation.

Status Summary: Phase I sampling (sediment and suspended sediment chemistry, ambient noise) occurred in summer 1999, with winter sampling scheduled for April 2000. Phase II (2000-2003) is planned for procurement this Fiscal Year.

Estimation of OCS Oil Spill Risk from Alaska North Slope, Trans-Alaska Pipeline, and Arctic Canada Spill Data Sets

Background: The historical record for the OCS statistics used to calculate the national OCS oil spill rates is mostly from the Gulf of Mexico. This spill record does not include pipeline spills inshore of the OCS, in State waters or on land. The MMS Alaska OCS Region intends to calculate spill frequency based on the Alaska North Slope and Arctic Canada rather than on the Gulf of Mexico experience, and to include all major pipeline spills, both onshore and offshore, in environmental impact assessment. This study is the first step in this process and will collate available information on oil industry spills of > 100 bbl in the Alaska North Slope and Arctic Canada, verify spill information for the larger spills (> 500 bbl), and estimate provisional spill rates for use for the Liberty EIS.

Objectives: The objectives of this study are to:

- Obtain and collate data on oil industry spills of ≥ 100 bbl.
- Review data reliability and completeness.
- Obtain and collate crude oil production, pipeline throughput, and pipeline mileage data by year.
- Evaluate appropriateness and statistical robustness of the oil spill data for estimating spill risks and provide provisional spill rate estimators.

Status Summary: The draft final report was reviewed by MMS, the contractor is completing the revised Final Report.

Alternative Oil Spill Occurrence Estimators for the Beaufort/Chukchi Sea OCS

Background: The historical record for the OCS statistics used to calculate the national OCS oil spill rates is mostly from the Gulf of Mexico. This spill record does not include pipeline spills inshore of the OCS, in State waters or on land. The MMS Alaska OCS Region intends to calculate spill frequency based on the Alaska North Slope and Arctic Canada rather than on the Gulf of Mexico experience, and to include all major pipeline spills, both onshore and offshore, in environmental impact assessment. The first step in this process was a preliminary study in FY 1999-2000 to collate readily available information on oil industry spills of ≥ 100 bbl in the Alaska North Slope and Arctic Canada, verify spill information for the larger spills (≥ 500 bbl), and to estimate provisional spill rates for use in the nearshore Beaufort Sea OCS.

The premise of this preliminary study was that in the nearshore, pipeline and platform spill rates can be extrapolated from the Alaska and Arctic Canada onshore oil spill experience. The validity of this premise cannot be assumed for locations further from shore that might be offered in future oil and gas lease sales.

Objectives: The objectives of this study are to:

- Provide statistical support to MMS in evaluating best statistical methods to estimate oil spill rates.
- Evaluate the applicability of the results from the preliminary study to deeper tracts that could be offered in Sale 176 or in subsequent sales.
- Evaluate alternative approaches to estimating oil spill risk for Beaufort Sea lease sales.

Status Summary: This study is in procurement phases. An RFP is planned to be issued this Fiscal Year.

Conference Management and Reports on MMS Results

Background: The Alaska ESP has organized many meetings on environmental studies information. Initially, synthesis meetings were sponsored through NOAA's OCS Environmental Assessment Program; the meetings involved scientists from many disciplines, and the main purpose was to synthesize their Alaska OCS information. During the past decade, the main focus has changed to small workshop for resolution of environmental issues and to large Information Transfer Meetings (ITMs) for the exchange of studies information among Principal Investigators and the general public. Also, the scope of the program changed to focus on a few prospective oil provinces on the Alaska OCS. During the 1970's and 1980's, most of the OCS environmental assessment information was collected through government-sponsored programs; however, during the past decade of exploration and development, a similar amount of environmental information has been collected through industry-sponsored, site-specific programs. In addition to the transfer of information through meetings, the ESP has transferred information through ITM Proceedings, reports and publications on MMS results.

Objectives: The objectives are to produce ITM's, small workshops, and publications on OCS environmental studies information. We will plan and fund the eighth Alaska ITM during FY 2000 and anticipate the need for a small workshop during FY 2001. An ITM will be funded in FY 2002.

Status Summary: The contractor is providing support to an Information Update Meeting in Fiscal Year 2000. The meeting is planned to be held in Barrow, Alaska in March, 2000.

APPENDIX G

PRELIMINARY SECTION 404(b)(1) EVALUATION— LIBERTY DEVELOPMENT PROJECT

This appendix was published as part of the Liberty Development and Production Plan (DPP) Draft Environmental Impact Statement (EIS) and was not revised for the Final EIS. The reader is referred to this appendix in the Draft EIS. This appendix is also available on the CD-ROM (MMS 2002-019 CD) and on the Internet (<http://www.mms.gov/alaska/cproject/liberty>).

APPENDIX G



Alaska District

Preliminary
Section 404(b)(1) Evaluation
Department of Army, Corps of Engineers
Alaska District

November 2000

6-981109
Foggy Island Bay 1

Liberty Development Project

**Preliminary Section 404(b)(1) Evaluation
Department of Army, Corps of Engineers
Alaska District**

Liberty Development Project

Notation: This is a preliminary Section 404(b)(1) Evaluation. As such it is a working draft with work (data collection and analysis) still in progress and without a Finding of Compliance or Non-compliance to the guidelines. The intent of circulating this preliminary evaluation is to foster coordination with the public and to solicit and focus public comment on the current direction of the 404 (b)(1) evaluation. A draft 404(b)(1) evaluation will be circulated with the Final Environmental Impact Statement.

The remaining data collection will include the additional collection of sediment samples for grain size analysis along the proposed pipeline routes during the current winter (2000-2001) season. The grain size analysis would include the silt and clay particle sizes analysis since these particle sizes have the greatest potential for movement and deposition away from proposed dredging and backfilling operations along the pipeline route. Additional analysis will include a state-of-the art modeling effort for prediction of suspended sediment transport. This advance modeling effort will utilize a modified SSFATE (Suspended Sediment FATE) software program to compute suspended sediments fields resulting from both dredging/excavation and placement of fill material through the water column. The SSFATE model would improve the prediction capability of the particle (suspended sediment) movement for quantity, duration and dispersion area effected by pipeline construction activity. The model efforts discussed in this evaluation assume a worst case analysis of a uniform Total Suspended Sediment (TSS) concentration of 1,000 mg/L along the pipeline route. The primary reason of additional data collection, advanced modeling effort and additional analysis is to further evaluate and assure that the potential for adverse impacts to the Boulder Patch," a unique biological community within the Beaufort Sea, is remote. Incorporation of the SSFATE model within this evaluation would also assist in the development of a construction-monitoring plan to include operational threshold criteria, should the Liberty Development Project be authorized.

I. Introduction

The primary Federal environmental statute governing the discharge of dredged or fill material into waters of the United States (inland of and including the 3-mile Territorial Sea) is the Federal Water Pollution Control Act, also called the Clean Water Act (CWA). Regulation of dredged material disposal within waters of the United States and ocean waters is a shared responsibility of the US Environmental Protection Agency (EPA) and the US Army Corps of Engineers (USACE). The primary Federal environmental statute governing the transportation of dredged material for the purpose of ocean disposal is the Marine Protection, Research and Sanctuaries Act (MPRSA) also called the Ocean Dumping Act. The geographical jurisdiction of the MPRSA and CWA overlap within the Territorial Sea concerning the disposal of dredged material. The precedence of MPRSA or the CWA in the area of the Territorial Sea is defined in 40 CFR §230.2(b) and 33 CFR §336.0(b). Appendix H provides the §103 evaluation for the proposed ocean water disposal of dredged material in Foggy Island Bay. Material dredged from navigable waters of the United States (for example, excess dredged material resulting from pipeline trench excavation), transported and disposed of in the Territorial Sea is evaluated under MPRSA. Dredged material discharged as fill material (e.g. excavated pipeline trench material which is utilized as backfill material) and placed within the 3-mile limit of Territorial Sea is evaluated under the CWA.



Figure 1. Geographical Jurisdiction of the MPRSA and CWA.

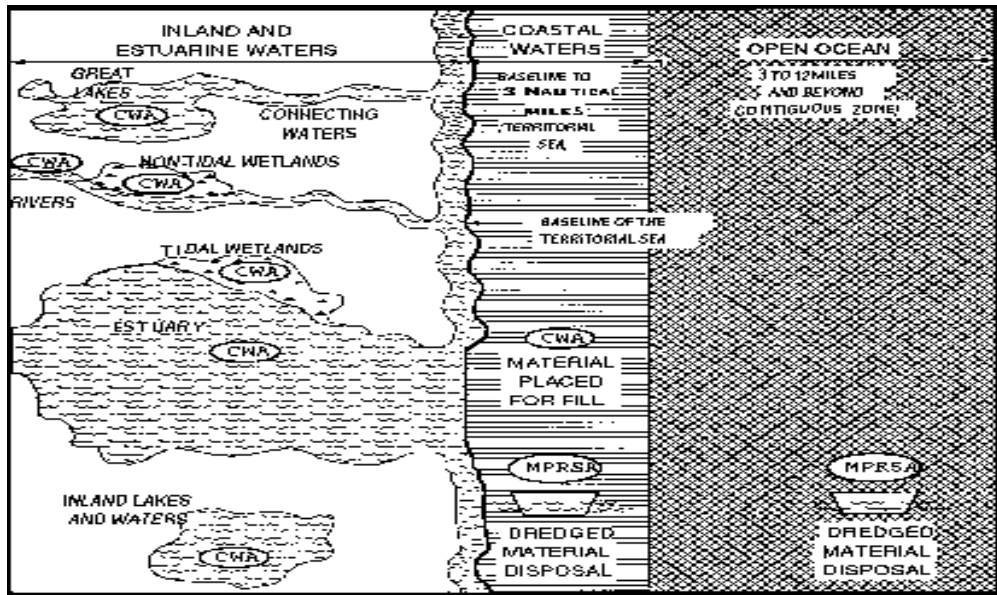

The proposed work description in the public notice includes activities (e.g. gravel island construction, transportation of dredged material for ocean water disposal, the disposal of dredged material in ocean waters, etc) that are outside the jurisdictional review under the Clean Water Act. [Gravel island construction is regulated under §10 of the Rivers and Harbors Act of 1899; and, the transportation of dredged material for purposes of dumping it in ocean waters under §103 of the Marine Protection, Research and Sanctuaries Act of 1972]. The activities under the jurisdiction of §404 CWA involve the placement of fill material within the territorial seas of the United States (3-mile limit) and inland waters of the United States.

These activities include:

- the placement of pipeline bedding material including placement of gravel bags over the pipeline (50,000 yd³, 55.4 acres) ;
- back-filling of the pipeline trench (495,000 yd³, 55.4 acres) ;
- placement of fill material for the pipeline transition zone (2,900 yd³, 0.3 acres);
- placement of fill material for construction of two gravel valve pads (8,000 yd³, 1.1 acres);
- stockpiling of excavated material at the Kadleroshilik River gravel mine site (215,500 yd³, 7 acres); and,
- placement of fill material in the gravel pit for reclamation purposes (up to 131,000 yd³, 2.5 acres within 31-acre area).



Table 1. Summary of CWA § 404 discharges (placement of fill) for the proposed Liberty Development Project (Alternative 1).

LIBERTY PROJECT COMPONENT	MAXIMUM DIMENSIONS (FEET)	FILL VOLUME (CUBIC YARDS)	FILL AREA (ACRES)
<u>Offshore Pipeline (3-mile limit to shoreline MLLW)</u>			
Trench (24,300' subsea pipeline to shoreline MLLW)	24,400 (length) x 61-132 (variable trench top width)		55.4
Gravel backfill (including bags)		50,000	
Native backfill (maximum)		495,000	
total 3-mile to shoreline MLLW		545,000	55.4
<u>Trench Transition (shoreline MLLW to landfall pad)</u>			
Gravel backfill	150 x 25	2,500	0.2
Native backfill		400	0.1
total Onshore Transition		2,900	0.3
<u>Landfall Valve Pad</u>			
	97 x 135	2,400	0.3
<u>Badami Pipeline Tie-In Pad</u>			
	54-155 x 170	3,500	0.5
<u>Mine Site</u>			
Cell 1 Mine Site:	910 x 1,225		
Backfill (overburden + unsuitable gravel fill material)	Stockpiled within Cell 2	up to 115,500	2.0
Cell 2 Mine Site	475 x 910		
1 st year, Temporary stockpiling of overburden	Within cell 2 limits 910 x 240	up to 100,000	5.0
2 nd year Backfill (overburden + unsuitable gravel fill material)	100 x 200	15,500	0.5 (on ice pad)
total Mine Site (up to 31 ac)		231,000	7.0
TOTAL		784,800	64



Figure 2. Proposed Liberty Island/Pipeline Route & Cross Section of Buried Sing Wall Pipeline Alternative 1. (proposed action)

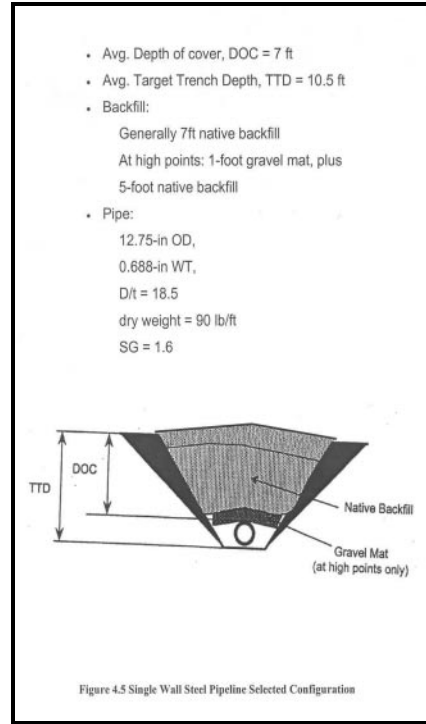
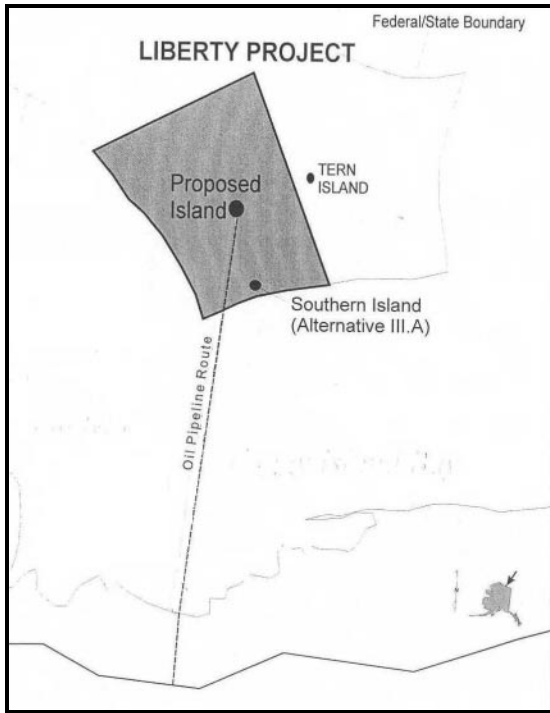

Figure 2: Southern Island/Pipeline Route (Left Side) & Cross Section of Buried Pipe-in-Pipe Pipeline (Right Side).

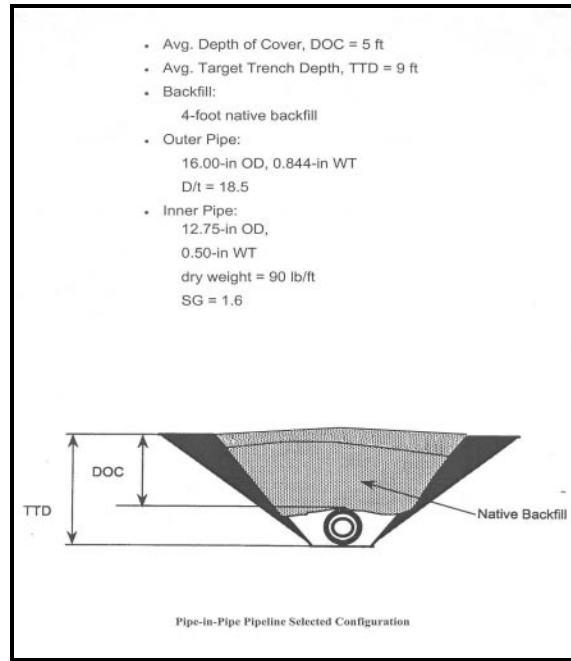
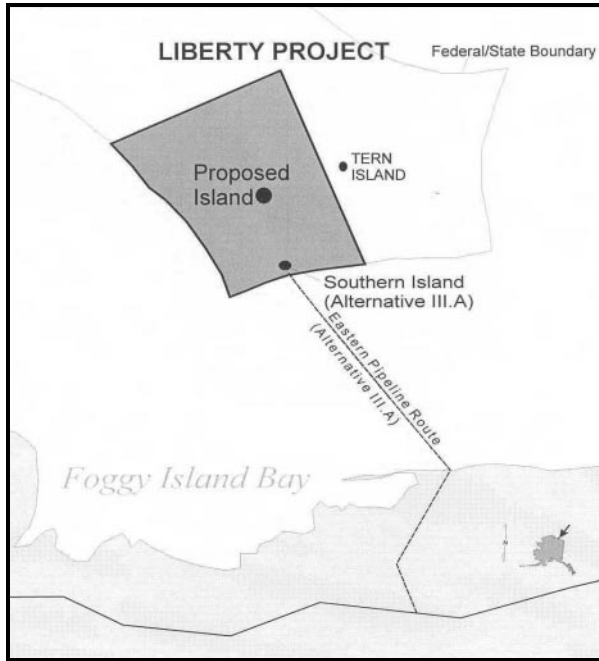

Table 2: Southern Island Alternative - Required Dimensions and Quantities with Pipe-in-Pipe Alternative.

LIBERTY PROJECT COMPONENT	MAXIMUM DIMENSIONS (FEET)	EXCAVATION (CUBIC YARDS)	FILL VOLUME (CUBIC YARDS)	FILL AREA (ACRES)
Southern Island				
Gravel Island	825 x 1,155		661,000	21.9
Gravel (4,200 bags for slope protection)			17,000	
Concrete blocks (16,000 for slope protection)			6,800	
Subtotal			684,800	21.9
Offshore Pipeline (Island to 3-mile limit)				
Trench Excavation (2,376' subsea pipeline)	2,376 (length) x 53-115 (variable trench top width)	(40,900)		
Select backfill (including bags/mats)			none	
Native backfill (maximum)			40,900	
Subtotal Offshore to 3-mile limit			40,900	4.6
Offshore Pipeline (3-mile limit to shoreline MLLW)				
Trench Excavation (19,900' subsea pipeline plus 100' transition pipeline below shoreline MLLW)	19,900 (length) x 53-115 (variable trench top width)	(342,300)		
Select backfill (including bags/mats)			none	
Native backfill (maximum)			342,300	
Subtotal 3-mile to shoreline MLLW			342,300	38.4
Onshore Transition Pipeline				
Trench (shoreline MLLW to landfall pad)	205 x 25 x 9	(2,570)		
Select backfill			2,950	0.24
Native backfill			470	0.12
Subtotal Onshore Transition			3,420	0.36
Landfall Pad	96.5 x 135		2,400	0.3
Badami Pipeline Tie-In Pad (approximate)	54-155 x 170		3,500	0.5



Figure 3: Tern Island/Pipeline Route (Left Side) & Cross Section of Buried Pipe-in-Pipe Pipeline (Right Side).

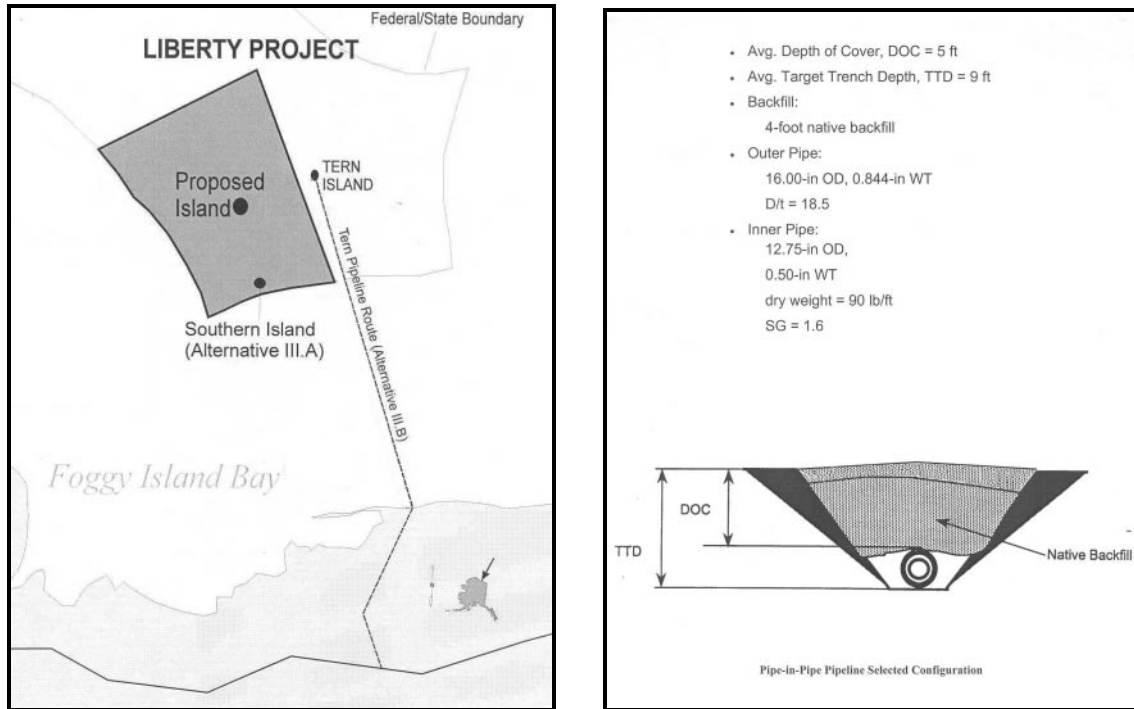

Table 3: Tern Island - Required Dimensions and Quantities.

LIBERTY PROJECT COMPONENT	MAXIMUM DIMENSIONS (FEET)	EXCAVATION (CUBIC YARDS)	FILL VOLUME (CUBIC YARDS)	FILL AREA (ACRES)
Tern Island				
Gravel Island	855 x 1,185		804,500	23.3
Existing Island Gravel Mass			(230,000)	
Gravel (4,200 bags for slope protection)			17,000	
Concrete blocks (18,000 for slope protection)			8,000	
Subtotal			599,500	23.3
Offshore Pipeline (Island to 3-mile limit)				
Trench Excavation (11,616' subsea pipeline)	11,616 (length) x 53-115 (variable trench top width)	(200,000)		
Select backfill (including bags/mats)			none	
Native backfill (maximum)			200,000	
Subtotal Offshore to 3-mile limit			200,000	22.4
Offshore Pipeline (3-mile limit to shoreline MLLW)				
Trench Excavation (17,524' subsea pipeline plus 100' transition pipeline below shoreline MLLW)	17,524 (length) x 53-115 (variable trench top width)	(301,500)		
Select backfill (including bags/mats)			none	
Native backfill (maximum)			301,500	
Subtotal 3-mile to shoreline MLLW			301,500	33.8
Onshore Transition Pipeline				
Trench (shoreline MLLW to landfall pad)	205 x 25 x 9	(2,570)		
Select backfill			2,950	0.24
Native backfill			470	0.12
Subtotal Onshore Transition			3,420	0.36
Landfall Pad	96.5 x 135		2,400	0.3
Badami Pipeline Tie-In Pad (approximate)	54-155 x 170		3,500	0.5



Figure 4: Comparison of the Proposed Trench Depth to the 15-foot Deep Trench.

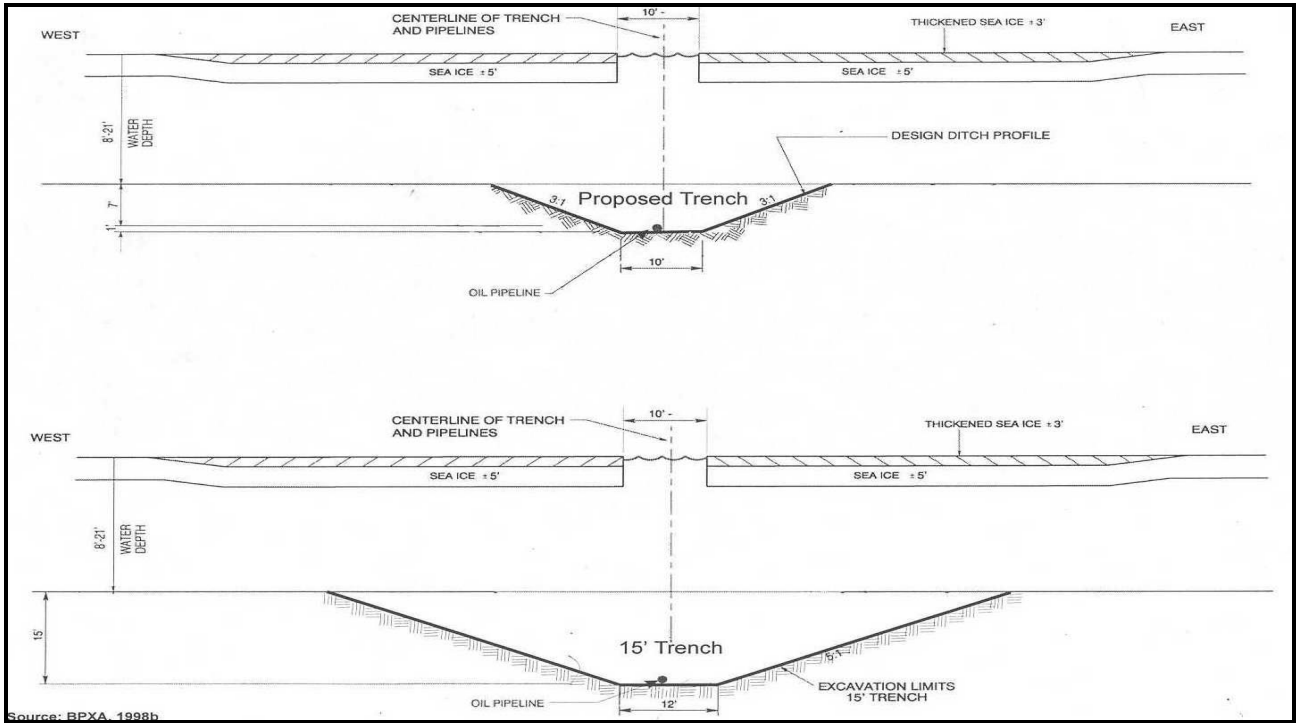

Table 4: Trenching Comparisons

DIFFERENT PIPELINES					
	Alternative I Single Wall Pipe	Alternative IV. A Pipe-in-Pipe	Alternative IV.B. Pipe-in-HDPE	Alternative IV.C Flexible Pipe	Alternative VI 15 ft Burial Depth
Designed Trench Depth	10.5 ft	9 ft	10 ft	8.5 ft	15 ft
Excavation Volume as Designed	460,650 yd ³	353,906 yd ³	423,626 yd ³	321,760 yd ³	863,460 yd ³
Excavation Volume as Requested on COE Permit	724,000 yd ³	556,000 yd ³	666,000 yd ³	506,000 yd ³	1,356,000 yd ³
Surface Area Disturbed	59 acres	52 acres	57 acres	49 acres	110 acres
Required Trenching Spread	118 days	91 days	108 days	82 days	226 days
Actual Trenching	30 days	23 days	27 days	21 days	58 days
Trenching Cost	\$7,080,000	\$5,460,000	\$6,480,000	\$4,920,000	\$13,560,000
DIFFERENT PIPELINE ROUTES (Using the 15' burial depth)					
	Alternative I Liberty Route	Alternative III.A. Eastern Route	Alternative III.B. Tern Island Route		
Excavation Volume @ 15' as Designed	863,460 yd ³	562,660 yd ³	843,870 yd ³		
Excavation Volume @ 15' as Requested on COE Permit	1,356,000 yd ³	884,000 yd ³	1,325,000 yd ³		
Excavation Volume @ 10.5' as Designed	460,650 yd ³	300,175 yd ³	450,200 yd ³		
Excavation Volume @ 10.5' as Requested on COE Permit	724,000 yd ³	472,000 yd ³	707,000 yd ³		



Figure 5: Liberty Island /Pipeline Route (Left Side) & Cross Section of Buried Pipe-in-Pipe Pipeline (Right Side)

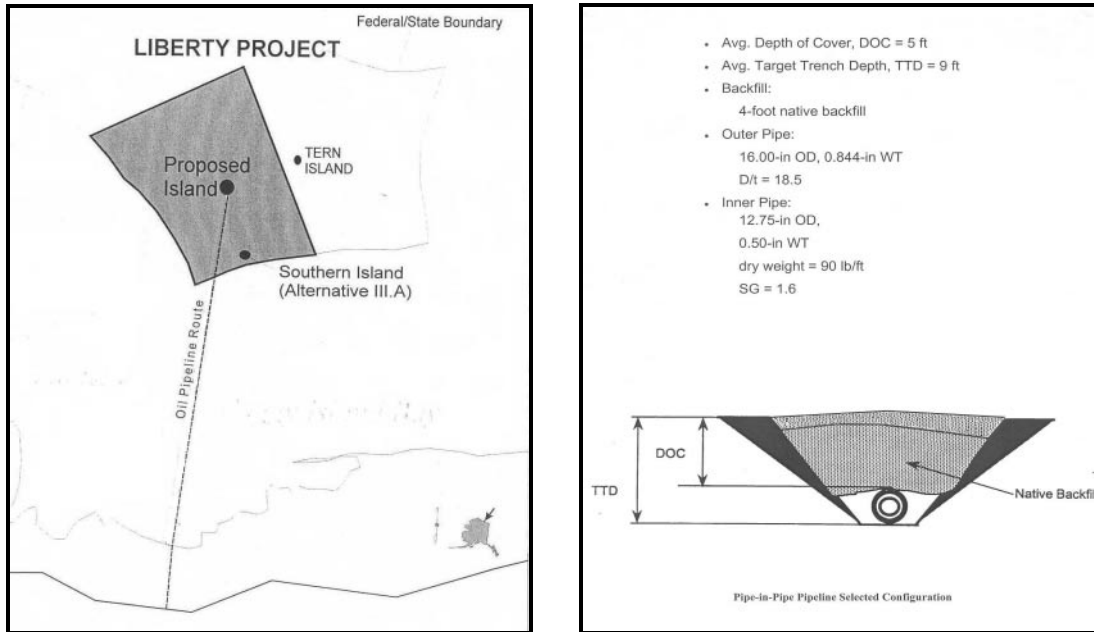

Table 5: Liberty Island Required Dimensions and Quantities with pipe-in-pipe alternative.

LIBERTY PROJECT COMPONENT	MAXIMUM DIMENSIONS (FEET)	EXCAVATION (CUBIC YARDS)	FILL VOLUME (CUBIC YARDS)	FILL AREA (ACRES)
Proposed Island				
Gravel Island	835 x 1,170		773,000	22.4
Gravel (4,200 bags for slope protection)			17,000	
Concrete blocks (17,000 for slope protection)			7,600	
Subtotal			797,600	22.4
Offshore Pipeline (Island to 3-mile limit)				
Trench Excavation (8,000' subsea pipeline)	8,000 (length) x 53-115 (variable trench top width)	(137,600)		
Select backfill (including bags/mats)			none	
Native backfill (maximum)			137,600	
Subtotal Offshore to 3-mile limit			137,600	15.4
Offshore Pipeline (3-mile limit to shoreline MLLW)				
Trench Excavation (24,300' subsea pipeline plus 100' transition pipeline below shoreline MLLW)	24,400 (length) x 53-115 (variable trench top width)	(419,700)		
Select backfill (including bags/mats)			none	
Native backfill (maximum)			419,700	
Subtotal 3-mile to shoreline MLLW			419,700	47.1
Onshore Transition Pipeline				
Trench (shoreline MLLW to landfall pad)	150 x 25 x 9	(1,875)		
Select backfill			2,160	0.17
Native backfill			345	0.09
Subtotal Onshore Transition			2,505	0.26
Landfall Pad	96.5 x 135		2,400	0.3
Badami Pipeline Tie-In Pad (approximate)	54-155 x 170		3,500	0.5



Figure 6: Location of Alternatives and Gravel Mine Site.

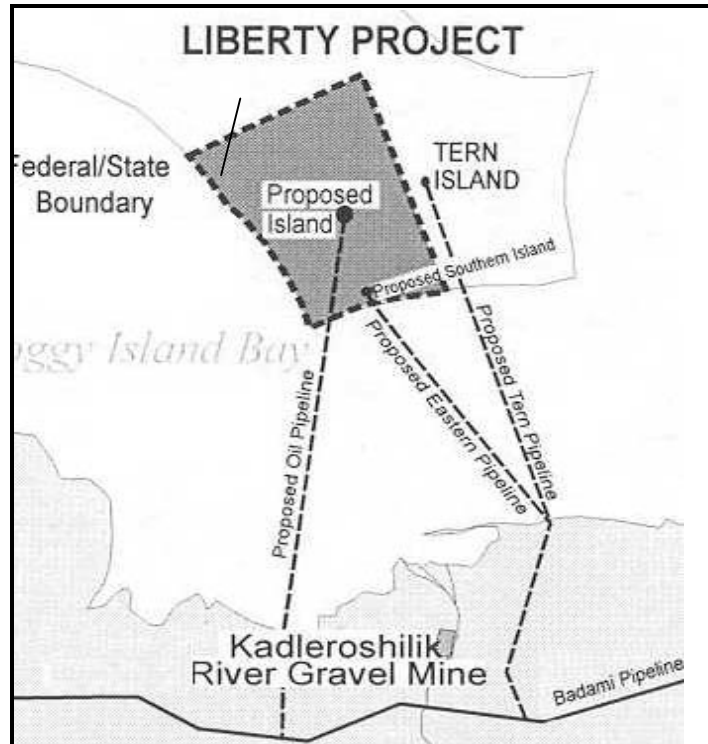

Table 6: Gravel Mine Site Dimensions and Volume Quantities.

LIBERTY PROJECT COMPONENT	MAXIMUM DIMENSIONS (FEET)	EXCAVATION (CUBIC YARDS)	FILL VOLUME (CUBIC YARDS)	FILL AREA (ACRES)
Mine Site				
Cell 1 Mine Site:	910 x 1,225	(800,000)		
Backfill = overburden + excess spoil from on-shore pipeline construction			Up to 115,500	Up to 2.0
Year 1 temporary stockpiling of overburden from Cell 1 on Cell 2 footprint	910 x 240		Up to 100,000 (temporary)	5.0
Cell 2 Mine Site:	475 x 910	(100,000)		
Year 2 temporary stockpiling of overburden from Cell 2 and on ice pad	110 x 200		15,500	0.5
Subtotal Mine Site		31 acres disturbed	215,500	7.0



**II. Evaluation of Compliance with 404(b)(1) Guidelines
[restrictions on discharge, 40 CFR § 230.10 (a)-(d)]**

(An * is marked above the answer that would indicate noncompliance with the guidelines. No * marked signifies the question does not relate to compliance or noncompliance with the guidelines. An "X" simply marks the answer to the question posed.) All chapter and section references are made to the Draft Environmental Impact Statement (DEIS), Liberty Development Project dated January 2001.

a. Alternatives Test:

Preliminary
Yes No

- | | | | |
|---|---|-------------------------------------|--------------------------|
| (i) Based on the discussions in the DEIS, are there available, practicable alternatives having less adverse impact on the aquatic ecosystem and without other significant adverse environmental consequences that do not involve discharges into "waters of the United States" or at other locations within these waters? <i>To Be Determined</i> | * | <input type="checkbox"/> | <input type="checkbox"/> |
| (ii) Based on discussions in the DEIS, if the project is in a special aquatic site and is not water dependent, has the applicant clearly demonstrated that there are no practicable alternative sites available?
<i>With exception to the proposed gravel mine site.</i> | | <input checked="" type="checkbox"/> | * |
| a. Kadleroshilik River Gravel Mine Site - <i>To Be Determined</i> | | <input type="checkbox"/> | <input type="checkbox"/> |

b. Special restriction. Will the discharge:

- | | | | |
|---|---|--------------------------|-------------------------------------|
| (i) violate State water quality standards? | * | <input type="checkbox"/> | <input checked="" type="checkbox"/> |
| (ii) violate toxic effluent standards (under Section 307 of the Act)? | * | <input type="checkbox"/> | <input checked="" type="checkbox"/> |
| (iii) jeopardize endangered or threatened species or their critical habitat? | * | <input type="checkbox"/> | <input checked="" type="checkbox"/> |
| (iv) violate standards set by the Department of Commerce to protect marine sanctuaries? | * | <input type="checkbox"/> | <input checked="" type="checkbox"/> |



(v) evaluation of the information in the DEIS indicates that the proposed discharge material meets testing exclusion criteria for the following reason(s):

Yes

No

*

(X) based on the above information, the material is not a carrier of contaminants.

(x) the levels of contaminants are substantially similar at the extraction and disposal sites and the discharge is not likely to result in degradation of the disposal site and pollutants will not be transported to less contaminated areas.

() acceptable constraints are available and will be implemented to reduce contamination to acceptable levels within the disposal site and prevent contaminants from being transported beyond the boundaries of the disposal site.

c. Other restrictions. Will the discharge contribute to significant degradation of "waters of the United States" through adverse impacts to:

Yes

No

(i) human health or welfare, through pollution of municipal water supplies, fish, shellfish, wildlife and special aquatic sites?

(ii) life stages of aquatic life and other wildlife?

(iii) diversity, productivity and stability of the aquatic life and other wildlife or wildlife habitat or loss of the capacity of wetland to assimilate nutrients, purify water or reduce wave energy?

(iv) recreational, aesthetic and economic values?

d. Actions to minimize potential adverse impacts (mitigation). Will all appropriate and practicable steps (40 CFR § 230.70-77, Subpart H) be taken to minimize the potential adverse impacts of the discharge on the aquatic ecosystem? *To be determined*

*



III. Factual Determinations
(40 CFR § 230.11)

The determinations of potential short-term or long-term effects of the proposed discharges of dredged or fill material on the physical, chemical and biological components of the aquatic environment included items a through h, below, in making a findings of compliance or non-compliance. There is minimal potential for short-term or long-term significant adverse environmental effects (in light of Subparts C through F) of the proposed discharge as related to:

	Yes	No
a. Physical substrate determinations	<input checked="" type="checkbox"/>	<input type="checkbox"/>
b. Water circulation, fluctuation and salinity determinations	<input checked="" type="checkbox"/>	<input type="checkbox"/>
c. Suspended particulate/turbidity determinations	<input checked="" type="checkbox"/>	<input type="checkbox"/>
d. Contaminant determinations	<input checked="" type="checkbox"/>	<input type="checkbox"/>
e. Aquatic ecosystem structure and function determinations	<input checked="" type="checkbox"/>	<input type="checkbox"/>
f. Proposed disposal site determination (disposal sites and/or size of mixing zone are acceptable)	<input checked="" type="checkbox"/>	<input type="checkbox"/>
g. Determination of cumulative effects on the aquatic ecosystem	<input checked="" type="checkbox"/>	<input type="checkbox"/>
h. Determination of secondary effects on the aquatic ecosystem	<input type="checkbox"/>	<input type="checkbox"/>



IV. Technical Evaluation Factors
40 CFR § 230 Subparts C-F

a. Potential Impacts on Physical and Chemical Characteristics of the Aquatic Ecosystem
 (Subpart C)

Significant
Not significant
N/A

1. Substrate	<input type="checkbox"/>	<input checked="" type="checkbox"/>	<input type="checkbox"/>
--------------	--------------------------	-------------------------------------	--------------------------

(EIS Section Reference)

- *Description of the Affected Environment* Section VI.C. Physical Environment
- *Seafloor Features.* Section VI.C.1.c.
- *Seafloor Sediment.* Section VI.C.1.c. (3)
- *Subsurface Features.* Section VI.C.1.c. (4)
- *Water Quality.* Section III.C.3.1.(b)
- *Gravel Mining* Section III.D.2.
- *Liberty Island Route Water and Sediment Sampling* Montgomery Watson, 1997.
- *Liberty Development Project. Gravel Mining & Rehabilitation Plan.* November 17, 1998. Submitted to ADF&G by BPXA.

Foggy Island Bay is located east of Prudhoe Bay between the Sagavanirktok River Delta (5.5 miles to the west), the Kadleroshilik River to the South and the Shaviovik River to the East. Foggy Island Bay is sheltered from the Arctic Ocean by the McClure group of barrier islands to the northeast. The proposed Liberty Island site is 6.5 miles West of Karluk Island in the McClure Island group in 22 feet of water.

Geophysical data were collected in the summer of 1997 to identify geological hazards and man-made materials that would affect or alter the design of the proposed Liberty Development (Watson Company 1998). The survey collected information from high-resolution multi-channel seismic systems, digital side scan sonar, and a sub-bottom profiler and did not identify any man-made structures or observable effects from human-use activities. Analysis of geophysical records determined that approximately 75 percent of the 1997 survey area consists of Holocene fine-grained materials characterized by low reflectivity with sparse or no apparent boulders (Watson Company 1998). Watson states that the Holocene sediments are relatively thin, less than 8.5 ft (2.6 m), with distributions characterized as small patchy accumulations of soft mud. While the deposits are considered to be marine sediments, the source may be fine-grained silts and clays discharged from the Sagavanirktok River (Watson Company, 1998).

Duane Miller & Associates conducted geotechnical exploration surveys in 1997 and 1998 along possible pipeline alignments, including the selected route. The following summarizes the subsurface conditions delineated during the survey, which included 18 borings along the pipeline



route. The seafloor sediments at the island location were divided into three primary horizons: the upper Holocene non-plastic silt; the intermediate Pleistocene clayey silt; and the underlying granular sand and gravel (Duane Miller & Associates, 1998). No frozen soils were encountered at any location along the offshore pipeline route. Soft silts were documented from the seafloor (0 ft) to a depth between 4 to 6 ft thick. The underlying stiff clayey silt horizon reached depths between 18 to 21.5 ft. This stratigraphy corresponds with the relatively flat seafloor with depths averaging 22 ft.

The seafloor rises gently from the 22-ft isobath to the 15 ft isobath where the sediments typically consists of sand, silty sand, with some soft silt, and many pockets and layers of peaty soil. A 4.5 ft thick shoal consisting of uniform fine-grained, clean sand was also identified. The sediments found in water depths between the 15-ft and 7-ft isobaths are silty sands interbedded with medium stiff silt to the maximum pipe burial depth of 10 ft. Stiff silt underlain by sandy gravel are found below. Between the 7-ft and 4-ft isobaths, the dominant material is silty sand with thin interbeds of silt and thin organic rich layers. Sediments in water depths less than 4 ft and extending to the shoreline consist of thin surface layers of sand and soft silt with the underlying sand and gravel at shallow depths 5 to 6 feet. Frozen ice bound sediments were observed up to 230 ft from shore.

The heterogeneous nature of the sediments encountered in borings located along the applicant’s proposed pipeline route indicate that no one grain-size sample describes the different sediments that will be removed from the pipeline trench. However, a representative grain-size distribution was estimated by computing the average percent fraction by weight for each sieve size from each sample collected within the sediments slated for trenching. Appendix A within Appendix G presents individual sample grain-size distributions and the resulting representative trench material grain-size distribution.

Sediment and water samples were collected from three proposed Liberty pipeline alignments. Transect A extended N-NW from shore at SW 1/2, Sec. 23, T10N., R.18E., Umiat Meridian to the applicant’s proposed island. Transect B extended N-NE from shore at SE 1/4, Sec. 24T.10N., R.17E Umiat Meridian to the proposed island. Transect C extended NW from the applicants proposed island location terminating at the Endicott Satellite Drilling Island.

A summary of sediment trace metal concentrations in Beaufort Sea sediments and waters between 1970 and 1998 is presented in Table VI.C.3 of the DEIS. Sediment samples (from Montgomery Watson 1997) along the proposed Liberty pipeline route during late winter in 1997 showed the following:

- arsenic 5.5 mg/Kg 0.43 mg/Kg coefficient of variation (standard deviation)
- total barium 67.5 mg/Kg 0.48 mg/Kg
- barium sulfate 27.5 mg/Kg 0.26 mg/Kg
- chromium 18.5 mg/Kg 0.38mg/Kg
(note: no hexavalent chromium reported above MRL of 3 mg/Kg)
- mercury 0.24 mg/Kg 1.03 mg/Kg
- lead 10.1 mg/Kg. 1.24 mg/Kg
- diesel range organics not detected



In 1998, sediment sample analysis, (the detection limits for PAHs (Polynuclear Aromatic Hydrocarbons) were more sensitive) five semivolatile PAHs were detected in four core samples. The PAHs and their concentrations are:

- Phenanthrene 0.033 mg/Kg
- 2-Methylnaphthalene 0.025 mg/Kg
- Benzo(a)pyrene 0.092 mg/Kg
- Phenol 0.038 mg/Kg
- 4 Methylphenol (p-Cresol) 280 mg/Kg

The potential sources for these types of PAHs are noted in Table III.C-11 of the EIS. These PAHs may be formed by:

- High-temperature pyrolysis of organic material
- Low- to moderate- temperature diagenesis of sedimentary organic material to form fossil fuels, and
- Direct biosynthesis by microbes and plants.

For additional information see Section VI. C.3.1(2)(b) and (d) of the EIS.

Observed geographic variations in the trace metal concentrations were attributed to grain size distribution and organic content. Similar observations were noted for the Northstar Project (31 miles west of Foggy Island) where the sediment chemistry values showed a strong correlation between the concentrations of chromium, lead, zinc, and trace metals with finer sediments. The major rivers are thought to be the major natural source for trace metals in the Beaufort Sea coastal sediments. Sediment aliphatic and aromatic hydrocarbon levels are relatively high in comparison to undeveloped outer continental shelf areas (e.g. Gulf of Mexico). The hydrocarbon composition differs from that of most other areas, because it is largely derived from fossil materials: onshore coal and shale deposits/outcrops and natural petroleum seeps that are drained by the rivers to the Beaufort Sea. See Section VI.C.2.b.(5) Hydrocarbons. There is no evidence that hydrocarbon concentrations in the sediments were derived from oil industry activities.

The proposed Liberty Project sediments are uniformly below the PSDDA (Puget Sound Dredging Disposal Analysis) screening level criteria for arsenic, lead and mercury. Arsenic, lead, mercury and 42 volatile and semi-volatile organic compounds are included in the list of PSDDA parameters. Results for analysis of discrete volatile and semi-volatiles were all below detection levels with the exception of acetone. The proposed Liberty project sediments are uniformly below the RBCs (Risk-Based Concentrations) which included total arsenic, lead, barium and compounds, mercury, chromium III and chromium VI. (Montgomery Watson, 1997)

Environmental Consequences

To the North and Northwest of the proposed island site is an area of mixed boulders, cobbles and pebbles in a stable hard bottom substrate. The area where rock cover equals or exceeds 25 % is commonly known as the "Boulder Patch". The Boulder Patch substrate is presumed to be deposited from the Flaxman Formation, a Pleistocene marine sandy mud containing boulders and cobble. Although boulders up to 6 feet across and 3 feet high are sometimes encountered, most rock cover in encountered occurs in the pebble to cobble size range. Additional information on the



characteristics of sediment dynamics within the Boulder Patch is provided in Attachment A, section 2.2, Letter Report, Liberty Development Project, dated January 17, 2000.

Use of trench excavation material as backfill material would not change existing sediment quality because it is representative of the sediments of the site. Consequently, the long-term effects on sediment/substrate from this activity are considered negligible. The backfilling with trench excavation materials would bury the gravel pipeline bedding material and polyester bags filled with 4-cubic yard gravel used for pipeline weights. Placement of backfill material would result in a minor change of bottom contours. Based on pre-application coordination and according to plans submitted, capping of the trench shall not exceed +1-foot within Zone 2 A, and shall not exceed +2-foot above existing bottom contours within Zone 2 B. Changes in bottom contours are expected to be temporary returning to near original conditions due to sediment settling, and storms and waves. The results of deposition model predictions of particles greater than 0.42 millimeters indicates that the particles could be deposited within 25 feet of the trench at a thickness of 2 to 120 millimeters. For particles less than 0.005 millimeters in size the deposition distance could range between 8 and 11 miles. The thickness of deposits at these distances is calculated to be about 0.02 millimeters. (Section III-C.3.1. *Water Quality*).

Excavation of the pipeline trench between the shoreline and the onshore valve pad (0.3 acres, 150' x 25' x 10.5') would remove 2,500 yd³ of soils/substrate and replace it with 2,500 yd³ of frost-stable gravel material. 400 yd³ of native soil would be used to cap the transition zone to provide a substrate for revegetation. Placement of 2,400 yd³ of gravel fill material for the construction of landfall gravel valve pad (97' x 135'), and the placement of 3,500 yd³ for the Badami Pipeline tie-in pad (155' x 170') would result in covering and compaction of 0.8 acre of native moist tundra soils which would have minor impact to onshore soils.

Gravel Mining and Site Rehabilitation. The applicant's proposed mine site is located on an island in the Kadleroshilik River about 1.4 miles upstream from the Beaufort Sea. Placement of fill material would occur as part of the site rehabilitation efforts. Up to 2.0 acres of the gravel mine site would be backfilled with organic overburden and unsuitable (for construction purposes) material to create and enhance a littoral shelf within the mine site in accordance with an approved rehabilitation. Placement of the organic fill material would provide for more productive substrate within the littoral zone of the rehabilitated mine site.

2. Suspended particulates/turbidity	<input type="checkbox"/>	<input checked="" type="checkbox"/>	<input type="checkbox"/>
-------------------------------------	--------------------------	-------------------------------------	--------------------------

- *Marine Water Quality* Section VI.C.2.
- *Turbidity*. Section VI.C. 2.b.(1)
- *Turbidity and Suspended Sediment*. Section 4.5.3. BPXA's Environmental Report
- *Letter Report. Liberty Development Project* dated January 17, 2000. Attachment A.
- *Water Quality. Effects of Constructing the Pipeline* Section III.C.3.1(b)

Suspended sediment concentrations in Foggy Island Bay are influenced by wind-induced waves and fresh water input from the Sagavanirktok, Kadleroshilik, and Shaviovik Rivers. These rivers produce high turbidity adjacent to river mouths. During spring breakup, the shallow nearshore waters carry more suspended material because of the high water events (e.g. spring break-up). Water from the Sagavanirktok River sampled in 1985 indicated the Total Suspended Solids (TSS)



ranged from 0.2 mg/L (late summer) to 30 mg/L (early summer) and turbidity ranged from 0.4 NTU to 24.0 NTU (nephelometric turbidity units) during summer months. Storms, wind and wave action, and coastal erosion increase turbidity in shallow waters. Satellite imagery and suspended particulate matter data indicate that turbid waters are generally confined to depths less than 16 feet and are shoreward of the barrier islands (Northstar DEIS). Peak suspended sediment concentration was associated with storms. The maximum value observed was 324 mg/L at a nearshore station where the average was 45 mg/L. Under the ice, TSS values along the proposed Liberty pipeline route ranged from 2.5 mg/L to 76.5 mg/L while turbidity ranged from 1 to 35.6 NTU (from BPXA's Environmental Report).

An offshore trenching test was conducted for the BPXA Northstar Project in March 1996. The test trench was excavated by a modified backhoe. Suspended solids concentrations monitored during excavation were found to range from 20 mg/L to 40 mg/L above background as measured near the seafloor at distances of up to 1,000 feet from the excavation. The TSS concentrations within 500 feet of the excavation ranged from 20 mg/L to 120 mg/L. Beyond 500 feet, TSS concentrations ranged from 19 mg/L to 121 mg/L above background levels. Based on the test trench data, a maximum probable distance of 830 feet was computed for under ice sediment plume transport due to excavation. For comparison purposes, the Northstar test trench sediments contain approximately 50% fines (materials less than 0.075mm) while Foggy Island Bay sediments consist of approximately 24% fines. However, sediments along the proposed pipeline route from a 6.5 ft. water depth (bottom fast ice depth) to the proposed island average 65% fines. Additional sediment sampling will be conducted during the 2000-2001 winter season for the proposed and alternative pipeline routes with emphasis on determining silt and clay concentrations. Silt and clay determinations are of major importance in determination of the sediment plume and deposition rates resulting from dredging/excavation and backfill operations.

The disturbance from placement of trench dredged material as backfill material and the addition of pipeline bedding material would result in a short-term increase in turbidity and TSS (EIS, Figure III.C-3). A turbid sediment plume would occur during the backfilling operation in those areas beneath the ice where the seawater has not become frozen (beyond the -8-foot MLLW depth) due to ice thickening adjacent to the pipeline. See section III.C.3.1.(2)(b) *Water Quality, Pipeline Construction Effects*. [Note: Of the 24,300 linear feet of subsea pipeline within the 3-mile limit, 14,700 linear feet would be in the bottomfast ice depth of -8-foot MLLW. That is, ice rather than an open water column would bound the placement of backfill and pipeline bedding material in the trench, resulting in little if any, turbidity plume and suspended sediment transport.]

As excavated materials are used to backfill the trench, the exposed finer grained particles would separate from the descending sediment mass in the water column with these finer particles becoming suspended within the water column. However exposure to the subfreezing temperatures likely would freeze some particles together and reduce the extent of particle separation. It is expected that the extent of the turbidity plume formed by these suspended sediments likely would be less than for the disposal of dredged material/spoils evaluated under section 103 evaluation (Appendix H), and less than predicted for excavation activities.



- *Marine Water Quality* Section VI.C.2
- *Oceanography of Foggy Island Bay* Section VI.C.5
- *Water Quality* Section III.A.2.1
- *Water Quality* Section III.C.3.1
- *Water Quality* Section III.D.1.1
- *Water Quality* Section III.D.2.1

Foggy Island Bay is a shallow embayment of Stefansson Sound with three rivers providing fresh water: Western distributaries of the Shaviotok River (eastern side of the bay), the Kadleroshilik River (central portion of the bay), and the East Channel of the Sagavanirktok River (western portion of the bay). In spring, melting of the sea ice begins at the surface, with meltwater accumulating on top of the ice. Seal holes and brine pockets form vertical channels draining through the sea ice. In early summer (late June to early July), the ice melts and rivers breakup and overflow on the sea ice. When the fresh water overflow encounters these brine channels, vortices form as the freshwater flows through the ice layer producing pits in the sea floor known as strudel scour. During this period open water off the river mouths is brackish while cold marine water lies adjacent to or below the surface layer. Discontinuous sea ice is prevalent throughout the central Beaufort Sea during early summer which limits the amount of wind stress applied to the water column. However westerly winds may bring offshore ice floes inshore. As the open water season progresses (about 75 days of open water) the water is exposed to the prevailing winds from the East. The winds influence the amount of mixing between the water-masses along the coast. Colonell and Niedoroda (1990) as cited in BPXA (1998) state that wind direction relative to the shoreline is more important than speed. Easterly winds promote offshore transport of surface waters, which is partially compensated by shoreward transport of bottom water (upwelling) increasing salinity in the nearshore areas. Conversely, westerly winds promote onshore transport of surface waters, which is partially compensated by offshore transport of bottom water (downwelling). Westerly winds often result in a reduction of near shore salinity because surface waters become brackish due to surface water from river discharges are contained near the shoreline.

Suspended sediment is introduced naturally to the marine environment through river runoff and coastal erosion and is re-suspended during the summer by wind and wave action. In mid-June through early July, the shallow inshore waters generally carry more suspended material, because runoff from the rivers produces very high turbidity adjacent to the river mouths. The turbidity resulting from high-water events blocks light and can reduce primary productivity of waters shallower than 40 feet. Total suspended solids in the river channels in 1985 (mid-July through September) ranged from 0.2 – 30.0 milligrams per liter. Maximum values correspond to midseason river discharge peaks following large rainfall events in the Brooks Range. The highest levels of suspended particles in the Sagavanirktok River occur during breakup ranging from 63 to 314 milligrams per liter (CE, 1993). In winter, suspended sediments under the sea ice range from 2.5 to 76.5 milligrams per liter. Field turbidity measurements for March (under-ice conditions) ranged from 1 to 35.6 NTU (nephelometric turbidity units) along the proposed pipeline route. Sea ice forms within Foggy Island Bay in September or October, typically along the shore where water is less saline. Initially the water is covered with brackish (floating slush) and pancake ice (small thin patches) that gradually thickens into sheet ice. As sea ice develops, the ice blocks



freeze into an ice sheet which grows to a typical thickness of about 6.5 feet by late winter through April and May.

Dissolved-oxygen levels during the open water season are usually high ranging, from 7.88 to 11.76 milligrams per liter. During open water season, the highest dissolved oxygen levels occur in the colder more saline waters near the bottom. During the winter (under ice cover) the dissolved oxygen levels seldom drop below 6 milligrams per liter. Under ice dissolved oxygen concentrations in March 1997 along the proposed Liberty pipeline route ranged from 7.6 to 13.2 milligrams per liter. Biological oxygen demand measured under the ice in late March of 1998, along the proposed Liberty pipeline was less than 1 milligram per liter (Montgomery Watson, 1998 as in Section VI.C.2.(b)(2)). The pH of seawater generally ranges from 7.8 to 8.2 and the pH of freshwater from 6 to 7.

In the past, there was a concern over the potential for depressed levels of dissolved oxygen in the water column, generally due to the higher oxygen demands associated with resuspension of fine-grain materials. However, upon examining data from warmer climate Corps dredging and disposal projects, open-water pipeline disposal operations where the dissolved oxygen decrease should be theoretically the greatest, near-surface dissolved oxygen levels of 8 to 9 ppm would be depressed during the operation by only 2 to 3 ppm at distances of 75 to 150 feet from the discharge point. The degree of oxygen depletion generally increases with depth and increasing concentrations of suspended solids; near-bottom levels could be less than 2 ppm. However, the dissolved oxygen levels increase with increasing distance from the discharge point, due to dilution and settling of the suspended material/sediments. No significant changes in dissolved oxygen levels are anticipated outside the immediate zone of the dredging and discharge of fill material. It is important to note that the estimates of TSS distribution as stated in the EIS are based on an over-simplification of potential suspended sediments that was developed to predict a “worst case” analysis for potential effects to the Boulder Patch community.

On-going work during the 2000-2001 winter season will include additional sediment sampling. To assist in this evaluation, a modified SSFATE model (see attachment C) would be utilized to provide TSS concentration contours in both horizontal and vertical planes, time series plots of suspended concentrations, and spatial distribution of sediments deposited on the sea floor. In addition, particle movement mapping would be undertaken in reference to the Boulder Patch community. The predicative assessment model would then be use in the development of an operational monitoring plan, should the project be authorized.

4. Alteration of current patterns and water circulation	<input type="checkbox"/> <input checked="" type="checkbox"/> <input type="checkbox"/>
---	---

- *Oceanography of Foggy Island Bay* Section VI.C.5
- *Circulation* Section VI.C.5.b
- *Currents* Section VI.C.5.c
- *Effects of Constructing the Pipeline* Section III.C.3.1.(2)(b)
- *Gravel Mining-Water Quality* Section III.D.2.1

Currents, circulation or drainage patterns: Base condition: Section VI.C.5.b. *Circulation*, section VI.C.5.c. *Currents* and Table VI.C-8; Section VI.C.5.e. *Tides and Storm Surges*; Section VI.C.5.g. *Sea Ice*; Section VI.C.5.f. *River Discharges* and Table VI.C-9. The project as proposed has no



appreciable effects. Under the ice current flow in the region is considered minor ranging from 0.04 to 0.14 miles per hour. During the pre-application phase the applicant had considered the possibility of a solid bottom fast ice-road along the pipeline trench right-of-way. Although this alternative could mitigate suspended particulates and turbidity, such an ice road could have had significant effects on currents and circulation during spring break-up. The applicant has dropped this alternative from further consideration.

5. Alteration of Normal Water fluctuations/hydroperiod	<input type="checkbox"/>	<input checked="" type="checkbox"/>	<input type="checkbox"/>
--	--------------------------	-------------------------------------	--------------------------

- *Tides and Storm Surges* Section VI.C.5.e
- *River Discharges* Section VI.C.5.f
- *Sea Ice* Section VI.C.5.g
- *Seasonal Generalities* Section VI.C.5.a

Extensive flooding is typically associated with rivers and streams on the Arctic Coastal Plain during spring breakup between May and early June. Breakup progresses rapidly, and by early July, 60% to 80% of the total annual discharges of most rivers has occurred. Flooding subsides as the river ice is broken up and melts or is carried out to sea. Spring breakup high flows are expected to fill the gravel mining area as intended for the mine site reclamation plan to enhance deepwater over-wintering fish habitat. No appreciable impact is expected from trench backfill placement and gravel mine rehabilitation.

6. Alteration of salinity gradients	<input type="checkbox"/>	<input checked="" type="checkbox"/>	<input type="checkbox"/>
-------------------------------------	--------------------------	-------------------------------------	--------------------------

- *Temperature and Salinity.* Section VI.C.5.d
- *Marine Water Quality* Section VI.C.2.
- *Water Quality* Section III.C.3.1.
- *Water Quality* Section III.D.1

Temperature and salinity values under the ice in the vicinity of the proposed pipeline route ranged from 28°F to 32°F, and 21ppt to 30 ppt, respectively. The construction activities are not expected to introduce or add any chemical contaminants. For the purpose of analysis, the DEIS used a 7,500 ppm suspended solids as an unofficial, acute toxic criterion for water quality. Trace metals and hydrocarbons could be added to the water column as excavated sediments along the pipeline route are returned to the marine environment, section III.C.3.1. MMS determined that trace metals observed in the sediment core samples came from natural sources. The average concentrations of several trace metals in sample cores taken along the pipeline route and in Foggy Island Bay are shown in Table V.C-3. The concentrations of chromium, lead, and barium in the core samples are below or within the range of concentrations found in the Beaufort Sea nearshore and bay sediments. Arsenic and mercury concentrations are less than or within the range of concentrations found in the Beaufort Sea shelf sediments. TableV.C-3 also shows that concentration arsenic, chromium, mercury and lead in the sediment cores from Foggy Island Bay are less than sediment quality criteria used to assess possible adverse biological effects from metals in the sediment. Section III.C.1(2)(b) addresses the results of core sampling for semi-volatile and volatile PAH's. No PAH's were detected in 1997 core samples. However with



greater detection limits in 1998, PAH's were detected in 4 core samples (Table VI.C-3, trace metals). Section III.D.2.1 discusses the effects of gravel mining on water quality and section III.D.6.1. addresses abandonment activities on water quality.

b. Potential Impacts on the Biological Characteristics of the Aquatic Ecosystem (Subpart D)

Significant	Not Significant	N/A
-------------	-----------------	-----

1. Threatened and endangered species (§230.30)	<input type="checkbox"/>	<input checked="" type="checkbox"/>	<input type="checkbox"/>
--	--------------------------	-------------------------------------	--------------------------

- *Threatened and endangered species* Section VI.A.1.
- *Threatened and endangered species* Section III.A.2.a
- *Threatened and endangered species* Section III.C.3.a
- *Threatened and endangered species* Section III.D.3.a
- *Threatened and endangered species* Section III.D.6.a
- *Threatened and endangered species* Section IV.C.1.a, c, d and e
- *Threatened and endangered species* Section IV.C.4.a and b
- *Threatened and endangered species* Section IV.D.3.a
- *Threatened and endangered species* Section V.C.1

The Western Arctic (Bering-Chukchi-Beaufort) stock of bowhead whales (*Balaena mysticetus*) is currently listed as endangered under the Endangered Species Act and is classified as a strategic stock by the National Marine Fisheries Service (NMFS) (Small and DeMaster 1995). The bowhead population, currently estimated at 8,000, is increasing by 2.3 percent per year (Small and DeMaster 1995).

Western Arctic bowheads winter in the central and western Bering Sea, summer in the Canadian Beaufort Sea, and migrate around Alaska in spring and autumn (Moore and Reeves 1993). Spring migration through the western Beaufort Sea occurs through offshore ice leads, generally from mid-April to mid-June. The migration corridor is located very far offshore of the Liberty Development area; however, a few bowheads have been observed in lagoon entrances and shoreward of the barrier islands (LGL et al. 1998). Autumn migration of bowheads into Alaskan waters occurs primarily during September and October. A few bowheads can be found offshore of the development area in late August during some years, but the main migration period begins in early to mid-September and ends by late October. During fall migration, most of the bowheads sighted were migrating in water ranging from 65- to 165-ft (20 to 50 m) deep. These migration corridors are all outside of the development area. When passing the development area, most bowheads are in depths > 65 ft (20 m), but a few occur closer to shore in some years.

In addition to the bowhead whale, there are two threatened or endangered bird species which may occur near the Liberty Development Project area. The spectacled eider (*Somateria fischeri*) is the only endangered or threatened bird likely to occur regularly in the study area. The Alaska-breeding population of the Steller's eider (*Polysticta stelleri*) was listed as threatened on July 11, 1997 by the U.S. Fish and Wildlife Service (62 *Federal Register* 31748). This species may occur in very low numbers in the Prudhoe Bay area and occasionally in the study area. The



Arctic Peregrine Falcon (*Falco peregrinus tundrius*) had been listed as threatened, but the U.S. Fish and Wildlife Service removed it from the list on October 5, 1994 (59 *Federal Register* 50796). The Eskimo curlew, although historically present, is now considered to be extirpated from the area.

The spectacled eider and the Steller's eider would not likely be affected since they are not expected to forage in the discharge area. Therefore, no direct effects of the discharge would occur. The endangered bowhead whale is also an unlikely visitor to the area inside of the barrier islands, and these mammals do not feed in the shallow waters surrounding Liberty Island.

2. Aquatic Food Web (§230.31)	<input type="checkbox"/>	<input checked="" type="checkbox"/>	<input type="checkbox"/>
-------------------------------	--------------------------	-------------------------------------	--------------------------

- *Lower Trophic-Level Organisms* Section VI.A.4
- *Lower Trophic-Level Organisms* Section III.A.2.e.; Section III.C.3.e.;
Section III.C.3.f.; Section III.E.3.e.;
Section III.D.6.e.; and Section V.C.5.
- *Liberty Development 1997-98 Boulder Patch Survey, Final Report* (July 1998) Coastal Frontiers Corporation LGL Ecological Research Associates.
- *Liberty Development: Construction Effects on the Boulder Patch Kelp Production.* (May 1999) Ban, Suzanne, et.al. URS Greiner Woodward Clyde, et.al.
- *Liberty Development Project, Environmental Report.* (February 1998) LGL Alaska Research Associates

Aquatic Organisms

No significant impacts are identified for phytoplankton, zooplankton, and benthic marine invertebrates, or the epontic community (living on the underside of sea ice) from the placement of fill material. The placement of gravel bedding material and trench backfill material would impact infauna and epifauna through direct physical disturbance, burial with sediments, or from increased turbidity. Impacts are considered short term and minor. Impacts are considered minor because of winter construction timing, recolonization potential of the species, the small area involved, and the short-term nature and magnitude of the impacts. Winter construction minimizes adverse impacts to the marine biota because fewer organisms are present and primary productivity is low during the winter and through ice cover.

The coastal lagoons of the Beaufort Sea are used as feeding grounds by many vertebrate consumers during the open water period from June to October. Benthic invertebrates are fed upon by marine mammals such as bearded seals and ring seals. Shallow water benthic communities also serve as the primary summer food source for ducks, many species of marine fish and the anadromous fish populations of the Alaskan North Slope. Faunal diversity is considered low (99 taxa of marine macrobenthos), which is typical for shallow, ice-stressed benthic systems of the Arctic. Epibenthic invertebrates were sampled in Foggy Island Bay in 1985 and 1986. Average biomass in Foggy Island Bay (range 0.4 to 0.8 grams per square meter, g/m²) was compared to Sagavanirktok River delta (0.1 to 1.2 g/m²), and Gwydyr Bay (0.5 to 0.7 g/m²). Invertebrate abundance was generally correlated with water temperature and salinity, with higher abundance in areas subject to mixing of fresh and marine waters.



The nearshore benthic communities are subject to natural events, which affect their distribution and relative abundance. These processes include storm waves during the open-water season, ice gouging and scouring during breakup and freezeup and deposition of sediment and organic material from high river discharges from the Sagavanirktok River. One of the largest annual fluctuations in the nearshore benthic community occurs in shallow waters where bottom fast ice occurs to depths of 6 feet during the winter and in the summer when the shallows are re-invaded by marine invertebrates. Beyond the 6-foot depth and to depths of 20-feet, the benthic communities are relatively diverse communities dominated by polychaetes, mollusks and crustaceans. The diversity and biomass of infauna increases with distance offshore, at least as far as the edge of the continental shelf. The abundance of phytoplankton appears to be greatest in nearshore waters with decreasing numbers farther offshore. Although vertical distributions vary, most reports show that phytoplankton abundance is the greatest at depths of less than 5-feet during the summer. Peak abundance occurs in July and early August due to increased light intensity. Sources of primary production include epontic algae, phytoplankton, and benthic microalgae. The natural turbidity of ice and the pattern of ice breakup influence the timing and degree of production by algae. The contribution of ice algae to annual productivity is small, but it provides a source of food in early spring when food supply is short. Benthic macroscopic algae, although limited in their occurrence, can provide as much as 56 percent of the annual primary production. Due to the small amount of primary productivity in the Alaskan Beaufort Sea, the zooplankton communities of this area are also impoverished and are characterized by low diversity, low biomass and slow growth.

Placement of up to 545,000 yd³ of trench backfill and gravel fill material within the 24,400 feet long trench within §404 waters would directly affect approximately 55.4 acres of soft-bottom (silty mud) benthic habitat of the trenches substrate footprint. The impacts from the pipeline trench backfilling would impact both infauna and epifauna through direct physical disturbance, burial with sediment, or from increased turbidity in the surrounding waters. Trenching and backfilling in shallow waters with bottom fast ice would have negligible effect on benthic invertebrates. Bottom fast ice in foggy island bay occurs to a depth of 6 to 8 feet of water. The biota in and on sediments under the bottom fast ice would already have moved, been frozen, or destroyed by natural process of ice movement prior to the commencement of trench construction and backfilling. Therefore, adverse impacts of trenching would be more predominate at depths deeper than the bottom fast ice. Since ice thickening would occur adjacent to the trench to support construction equipment, these impacts would more likely occur at depths greater than 8 feet. Organisms contained in trench dredged material temporarily stored on the ice or immediately used as backfill material, would probably die from freezing, mechanical damage or be smothered. Stationary organisms such as clams and worms would be most at risk, although mobile species (isopods and amphipods) could also be affected. Potential effects of trench backfilling on organisms living in or on sediments adjacent to the trench include suffocation from burial, crushing from ice removal, and physiological stress due to increased turbidity during trenching activities. A study (Canada, Fisheries and Marine Service, 1978) of the construction of 16 artificial islands in the Canadian Beaufort Sea indicated increases in sedimentation occurred locally, with resultant destruction of benthos due to smothering during construction. One study documented an increase in sedimentation within approximately 10,000 feet (3200 m) down current of the island construction site. Local destruction of benthos was documented with a 1,000-foot (100 m) radius of the site. Outside this zone of direct smothering, no effect was observed on the density or total biomass of benthic organisms.



Suspended-sediment concentrations in the water column greater than 100 mg/L were estimated to occur within 0.5 miles of the trench during the Liberty pipeline construction based on maximum horizontal transport as a function of current speed and water depth beneath 6 feet of ice cover. Concentrations of 20 and 10 mg/L are estimated (worst case) to reach about 1 mile and 6 miles respectively. These maximum estimates are based on an initial suspended sediment concentration of 1,000 mg/L and current velocity of 0.4 knots that carries the sediment to the Northwest (Section III-C.1.(2)(b) and Attachment A to this appendix).

Although, turbidity resulting from the silt plume (see suspended sediments and turbidity, above) could also affect organisms, it is not expected to cause a measurable reduction in their abundance beyond the range of natural variability or have a measurable effect beyond those affected by natural variability. Natural occurring highly turbid conditions that occur during the spring breakup period would mask this type of construction impact. For epontic algae (primarily pennate diatoms and microflagellates), removal of the ice cover over the trench would result in mortality for the individuals living on the sections of removed ice. Side casting dredged material, temporarily, on top of the ice could reduce light transmission through the clear ice during the winter and spring months (estimated to be 25% of surface area). Reduction in light availability and intensity in clear ice areas could effect photosynthesis. However, due to the small area involved when compared to Foggy Island Bay, impacts would not be appreciable. Recolonization of the disturbed bottom sediments would occur within a few years after construction and long-term productivity would not be adversely affected.

Boulder Patch

Researchers from the U.S. Geological Survey discovered the Stefansson Sound Boulder Patch in the early 1970's. Stefansson Sound provides the necessary combination of rocky substrate, sufficient free water depth (12- to 14-ft) under the ice during winter, and presence of offshore shoals and barrier islands that protects the area from ice effects. (Dunton and Schonberg 1981). Scattered boulders, cobbles and pebbles that support a rich epilithic flora and fauna, including kelp (*Laminaria sp.*) beds, characterize the Boulder Patch. Water depth is also an important factor in determining Boulder Patch habitat. The habitat is not found at depths less than 6 feet due to seasonal presence of bottomfast ice and beyond to 12 feet in the upper shoreface of Stefansson Sound due its depositional nature making it unsuitable for kelp community development. Benthic-dwelling kelp do not thrive in depositional environments. The distribution of kelp bed communities in Stefansson Sound is generally restricted to depths greater than 10 feet. The Stefansson Sound Boulder Patch habitat is estimated to occupy 15,871 acres of seabed in the Liberty development study area (Attachment A). Although boulders up to 2 meters across and 1 meter high are sometimes encountered, most of the rock cover occurs in the pebble to cobble size range (2 to 256 mm on the modified Wentworth Scale). The percent of kelp concentrations are correlated with rock concentrations in identifying Boulder Patch habitat.

In 1980, the Arctic Biological Task Force provided a definition of a “significant biological community” as “kelp attached to boulders in concentrations greater than 10 percent in 100 square meters. A similar definition under a General National Pollutant Discharge Elimination System (NPDES) permit (AKG284200) issued by EPA for discharges from oil and gas exploration facilities on the Outer Continental Shelf and in contiguous waters stated “an area which has more than 10 percent of a one-hundred square meter area covered by boulders to which kelp is attached.” With these definitions of a significant biological community, the applicant contracted a 1997-98 survey for the purpose of identifying Boulder Patch habitat within the Liberty Prospect Area (OCS-Y-1650). See figure III.C-1 for boulder and kelp survey results. Only ‘none’ (<2%



kelp concentration) and 'light' (>2% to <10% kelp concentrations) were detected along the proposed routes. The alternative pipeline route to the Endicott Satellite Drilling Island encountered 'medium' (10% to 25% kelp concentrations) and 'heavy' (25% kelp concentrations). (The pipeline alternative to the Satellite Drilling Island was deleted from detailed study, because of the potential impacts to the Boulder Patch).

The boulders and attached dominant kelp species, *Laminaria solidungula*, provide habitat for many invertebrate species. Sponges and cnidarians, including the soft coral *Gersemia rubiformis*, are the most conspicuous invertebrates. Approximately 98 percent of the carbon produced annually in the Boulder Patch is derived from kelp and phytoplankton. *Laminaria* is estimated to contribute 50 to 56 percent of the annual production depending on whether the plants are beneath clear or turbid ice (Dunton 1984). Photosynthesis is limited to a short period annually when light is available and ice cover has receded. *Laminaria* then stores food reserves until winter and early spring when nutrients are available. As a result, blade elongation (growth) is greatest during periods of darkness and turbid ice cover (Dunton and Schell 1986). The only herbivore that consumes kelp in the Boulder Patch is the chiton, *Amicula vestita* (Dunton 1984).

The summary and conclusions of the Liberty Development 1997-98 Boulder Patch Survey (Coastal Frontiers, July 1998) indicate that:

- Of the 136 miles of track lines surveyed (Figure III.C-1, EIS) along 15 North-South transects and three short intermediate lines in Stefansson Sound, 25% was found to contain rock concentrations in excess of 10% of the sea bottom. An additional 10% was characterized by rock concentrations less than or equal to 10% and greater than 2%, while the remaining 65% contained no significant rock substrate. The heaviest rock concentrations (correlating to the kelp densities) were located to the north and northwest of the planned Liberty Island and applicant's preferred pipeline route.
- Of the three candidate pipeline routes surveyed, only the Endicott route was found to contain Boulder Patch habitat (>10% rock). In contrast, no hard substrate (rock) was detected along the East Pipeline Route. Likewise, the west Pipeline Route did not exceed or approach the 10% minimum value specified in the Definition of Boulder Patch habitat. This finding was confirmed during the winter with video footage. Hard surface objects identified as scattered sonar targets were found to be clay lumps and ridges, etc. and were widely scattered and devoid of biologically-significant kelp communities.
- The planned Liberty Development island site and variations of the west and east pipeline route do not harbor kelp communities, nor do these sites possess the attributes requisite for kelp community development.

Pipeline trenching (not regulated under §404 CWA) and subsequent backfilling activities would result in suspension of sediment into the water column that was not frozen (ice). Bottomfast ice is expected along 14,700 linear feet of the 24,400 linear feet of the subsea pipeline route within the 3-mile limit. In the bottomfast ice area (less than -8 feet MLLW, normally 6-foot but 8-foot is used due to ice strengthening efforts, ice roads, for construction purposes) little water would be expected between the ice and the sediment. As a result, no appreciable impacts due to suspended sediments in the water column would occur.

Suspended sediment results when the small sediment particles (smaller than a grain of sand) called fines (silts, clay particles, etc) are suspended in the water column during construction activities such as dredging or placement of fill material through the water column and remain suspended, slowly settling to the bottom. Suspended sediments do occur naturally such as from



wave action, river discharges, etc. The amount of suspended sediment and plume size is dependent on the size of the particles, its cohesiveness characteristics and under ice currents.

Increased suspended sediment concentrations resulting from the pipeline trenching activity within the remaining 9,700 linear feet of pipeline route deeper than 8 feet below MLLW within the 3-mile limit are of concern because they could reduce light penetration into the water column. Reduction in available light including potential deposition on the kelp could adversely impact kelp by decreasing light available for photosynthesis. If significant suspended sediment concentration and deposition on the kelp occurred over the long-term (>3-5 years) the entire Boulder Patch flora and fauna community could be affected.

Winter excavation of the pipeline trench and the required backfilling would be accomplished with a backhoe equipped with a 2 to 4 y³ bucket and front end loaders. As the backhoe bucket is lifted through the water column, the flow of water over the top of the bucket would wash a small portion of the fines from the exposed surface of the sediment. The amount of fines washed out of the backhoe will also be dependent upon the depth of the water column through which the backhoe is raised. Likewise, the amount of fines that will be washed out from spoils and fill material during backfill operation is also dependent on the depth of the water column. Backhoes will excavate material to the required trench depth and could repeat an excavation cycle about once a minute. A front end loader would operate in tandem with the backhoe for loading spoils (dredged/excavated material) and transporting it to be backfilled in a nearby trench section where the pipeline has been laid. Trench backfill would include both native spoils and gravel for bedding material needed for pipeline support.

An hydraulic dredge (agitator pump) could be used when need to achieve trench bottom smoothness for pipe integrity and in cases where slumping of the trench side walls require cleanout. The agitator pump is a relatively small cutter-suction pump dredge that would be mounted on the backhoe arm or suspended from a platform on top of the ice to control vertical and horizontal movement. A discharge hose (up to 10 inches in diameter) would trail about 200 to 300 feet behind the dredge with the discharge nozzle tethered so not to contact the installed pipe and directed back into or immediately adjacent to the trench. It is estimated that the dredged material would consist of 60 to 70% solids and 30 to 40% percent liquid. Excavation/dredge rate is estimated at 150 y³ per hour. Use of a hydraulic dredge or similar dredge equipment is expected to be less than 10% of the excavated material for construction of the total pipeline trench.

The excavation method used for Northstar Development Project test trench is comparable to that anticipated for Liberty. A water sample collected at the seafloor during trenching operations had a total suspended concentration (TSS) of 855 mg/L. Samples collected within 150 m of the trench showed TSS concentrations from 20 to 121 mg/L, while beyond 150 m TSS concentrations ranged from 19 to 35 mg/L (Montgomery Watson 1996). For the purpose of estimating effects of operations, it was assumed that the initial XSS (amount of TSS above ambient) concentration would be 1,000 mg/L from seabed to the underside of the sea ice, over the entire length of the pipeline trench. This corresponds approximately to assuming sediment entrainments of 2% in ~3-foot water depth, and up to 10% in ~15 feet water column (beneath the ice). Computational results from the models showed that during the winter, even with initial concentrations of 1,000 mg/L at the pipeline, all but 10-20 mg/L has fallen to the seabed prior to reaching significant portions of the Boulder Patch (Figure III.C-3 of the EIS).



The increase in the sediment load attributable to excavation and backfilling the trench is a transient. This is because the origin is a short-term moving point source, that is moving as the backhoes and frontend loaders move along the pipeline route, generating sediment clouds (plumes) that are carried to the northwest by the prevailing currents. As such, any given point on the seabed is affected by the potential sediment cloud for only a short time (generally <2days). Accordingly, the areas depicted in Figure III.C-1 (EIS) are maximum exposures occurring when general circulation is westward and should be regarded only as envelopes of sediment cloud trajectories over the Boulder Patch. Westward circulation occurs on an average 60-70% of the time.

Table 4-1 of the *Liberty Development: Construction Effects on Boulder Patch Kelp Production* (1999) report (Attachment B) summarizes the maximum extent and duration of overall construction-induced excess suspended sediments on the Boulder Patch. The report estimates a maximum kelp productivity reduction of 2-4% in a year (short-term). The authors also point out that the above estimate should be considered conservative (i.e. an over-estimate of effects) because they result from compounding of conservative assumptions taken in estimating both the physical and biological effects. The researchers believe that the duration of the construction effects would be short term and are based on previous observations of kelp response to, and recovery from, naturally occurring adverse conditions. In 1998, storm-induced decreases in water transparency during the summer open-water period resulted in significant reduction in kelp health and, ultimately, in plant growth and productivity. However, the kelp health, growth and productivity returned to normal levels the following year as water transparency returned to normal (Dutton 1990, as in Attachment A). Since the kelp are highly sensitive to changes in underwater irradiance, they respond quickly to increases in water transparency. Impacts to kelp productivity are thus typically short-term and limited to the period characterized by low light and even potential maximum impacts are not expected to result in long-term damage to the Boulder Patch kelp community (Ban, et.al. 1999)

See Section III.C.3.e (1) *Summary and conclusion on the effects on lower trophic-level organisms* and III.C.3e. (3) *How disturbances from pipeline construction may affect these organisms* for further discussion on the effects resulting from pipeline construction including the placement of fill material.

Fish

No significant impacts are identified for marine species, anadromous species or freshwater species from the §404 discharges (placement of trench backfill and pipeline bedding material and backfill material for the rehabilitation of the gravel mine site). The placement of gravel bedding material and trench backfill material could impact fish through direct physical disturbance, burial with sediments, or from increased turbidity/suspended sediments. Construction impacts are considered temporary and minor. Impacts are considered minor because of winter construction timing, fish mobility, the small area involved, and the short-term nature and magnitude of the impacts. Winter construction timing minimizes adverse impacts to the fisheries because fewer fish are present. No significant long-term effects are anticipated resulting from the placement of fill material for the pipeline trench. The placement of overburden and unusable gravel would enhance rehabilitation efforts of the gravel mine site and should have long-term beneficial effects by primarily providing additional over-wintering fish habitat.

There are three basic categories of Beaufort Sea fish species: freshwater, anadromous (including amphidromous species, species that migrate between freshwater and marine water for purposes



other than spawning) and marine. Freshwater species that venture into coastal waters are found almost exclusively in association with fresh or brackish waters extending offshore from major river deltas. Their presence in the marine environment generally is sporadic with peak occurrence probably during or immediately following breakup. Freshwater species include arctic grayling, round whitefish, and burbot. The Arctic grayling is considered the most important freshwater species. Anadromous species consist of arctic char, arctic, least and Bering cisco; broad and humpback whitefish, pink and chum salmon, and rainbow smelt. Arctic cisco, Arctic char, least cisco and the broad whitefish are the most abundant anadromous species, combined with the marine species (Arctic cod and fourhorn sculpin) make up 94% of the total catch from previous monitoring studies within the nearshore zone. The Arctic char, ciscos and whitefish move into and disperse through the nearshore coastal waters during early June. During the 3- to 4-month open-water season they feed heavily building up their energy reserves used for over-wintering and spawning activities that occur in fresh or brackish water habitats. During the winter, when bottom-fast ice occurs in the nearshore zone, these anadromous fish concentrate in the deep, unfrozen pockets of fresh water in the North Slope rivers and lakes. Forty-three marine species have been reported from the Alaskan Beaufort Sea. The most widespread and abundant species are the Arctic cod, the saffron cod, twohorn and fourhorn sculpins, the Canadian eelpout, and the Arctic flounder. In nearshore waters, the fourhorn sculpin, capelin, and the nine-spine stickleback are important numerically. Arctic cod sporadically enter the nearshore areas to feed on the abundant epibenthic fauna or to spawn. In general, the Arctic cod are more abundant in nearshore habitats during the later half of the open water season, probably in response to favorable salinity (10 to 20 ppt) and warmer temperature conditions. Others such as the fourhorn sculpin and flounder remain in coastal waters throughout the ice-free period, then move farther offshore with the formation of bottom-fast ice during the winter. Arctic cod spawn under the ice between January and February with spawning occurring in both shallow coastal and offshore waters. The Arctic cod has been described as a “key species in the ecosystem of the Arctic Ocean” due to its distribution, abundance and importance in the diets of many other fish, birds and marine mammals.

Only marine species would be affected from the placement of pipeline bedding material (gravel) and backfilling of the pipeline trench. Marine fish could be impacted by increases in suspended sediments and turbidity, smothering due to displaced sediments, smothering of prey organisms, direct mortality resulting from operation of trenching equipment, and temporary displacement from the area due to the disruption from trenching activities including noise. Sculpins, snail fish and other marine species that are oriented to the seafloor are more likely to be affected. Fish such as the Arctic cod, Arctic char, Arctic cisco, broad whitefish, humpback whitefish, and rainbow smelt are able to tolerate turbid waters, up to 146 NTU during breakup conditions. However, some Arctic cod may spawn under the ice in shallow coastal areas as well as in offshore waters. The kelp snail fish and the leatherfin lump sucker also spawn during the winter by attaching their eggs to solid substrates such as found in the Stefansson Sound Boulder Patch. Sedimentation of suspended solids resulting from the trench backfill could have an adverse effect on these eggs should sedimentation become significant over the Boulder Patch and ultimately over the eggs.

Gravel Mine Site. The Alaska Department of Fish and Game *Catalog of Waters Important for Spawning, Rearing or Migration of Anadromous Fish (1992)* identifies the Kadleroshilik River (Id. # 330-00-10320) as containing anadromous fish (Arctic char/Dolly Varden). The Arctic char is the most abundant and widely distributed of the five anadromous fish (Arctic char, broad whitefish, Arctic cisco, and occasionally pink and chum salmon) inhabiting the study area. There are no known over-wintering areas along the lower Kadleroshilik River



The proposed mine site is an island area, approximately 6 to 10 feet above sea level, and lies between channels of the Kadleroshilik River, approximately 1.4 miles upriver from Foggy Island Bay. Gravel mining will not extend into the active river channel. Adverse impacts are not expected due to the winter construction and the separation of the mine operations from the river. A dike, approximately 50 feet wide will be left in place between the mine site and the river channel while mining operations are underway. The purpose of the placement of fill material associated with the mine site rehabilitation is to minimize the effects of mining and create improved aquatic habitat conditions. The overall objective of the rehabilitation effort is to flood the excavated cells, creating a deep lake connected to the active river channel, providing fish over-wintering habitat. Use of the overburden allows development of a more diverse habitat within the lake (creating a shallow littoral zone). To the extent practical the backfilling would be conducted to produce an irregularly shaped boundary that should result in a more natural looking lake. Placement of fill material would be required as part of the mine site rehabilitation plan in coordination with the Alaska Department of Fish and Game, Alaska Department of Natural Resources, Alaska Department of Environmental Conservation, U.S. Fish and Wildlife Service, U.S. Army Corps of Engineers, and the North Slope Borough.

Development and rehabilitation of the mine site (31 acres) would occur in two phases. During phase 1 cell development (19 acres), overburden and unusable would be stockpiled within the phase 2 cell footprint. After the phase 1 cell gravel excavation is completed and prior to breakup, overburden would be used to create a ledge along one side of the cell (approximately 2 acres), the dike separating the cell from the river would be breached and allowed to flood. During development of the phase 2 cell, a 15-foot wide dike would remain in place separating the two cells. Upon completion of cell 2 excavation, the backfilling and shelf contouring, the dike would be breached (about three feet below the top of the ice in cell 1) to form islands between the two cells when it floods during breakup. One area of the cell 2 dike area would be excavated to riverbed level to avoid trapping fish during low water periods. After a thaw season and as a result of thermokarsting, it is expected that irregular settlement comprising the shelf and Lake Boundaries will create a mosaic of small ponds, humps and flats. The coordinated rehabilitation plan will include a revegetation component for the littoral areas and islands. After rehabilitation, the flooded mine site would provide several benefits. Deep-water sources connected to streams and rivers are uncommon in this area. The excavation would create potential overwintering habitat for fish in an area where this type of habitat is limited.

3. Other wildlife	<input type="checkbox"/> <input checked="" type="checkbox"/> <input type="checkbox"/>
-------------------	---

- *Seals and Polar Bears* Section VI.A.2
- *Seals and Polar Bears* Section III.A.2.b.; Section III.C.2.b and 3b;
Section III.D.1b, 2b and 3.b.; Section III.D.6b.;
Section III.C.3.b.;and, Section IV.D.3.b
- *Marine and Coastal Birds* Section VI.A.3
- *Marine and Coastal Birds* Section III.A.2.c.; Section III.C.2c and 3.c.;
Section III.D.2c and 3.c.; Section IV.D.3.c.
- *Terrestrial Mammals* Section VI.A.4
- *Terrestrial Mammals* Section III.A.2.d.; Section III.C.3.d.;
Section III.D1d., 2d. and, 3.d.; Section IV.D.3.d.
- *Terrestrial Mammals* Section V.C.4.



No significant impacts are identified for marine mammals, terrestrial mammals, or birds from the §404 discharges (placement of trench backfill and pipeline bedding material and backfill material for the rehabilitation of the gravel mine site). As a mitigation measure, BP Exploration would develop and implement a wildlife interaction plan. This plan will include measures to avoid wildlife attractants and will address human/wildlife interaction.

c. Potential Impacts on Special Aquatic Sites (Subpart E)

1. Wetlands	<input type="checkbox"/> <input checked="" type="checkbox"/> <input type="checkbox"/>
-------------	---

- *Vegetation-Wetland Habitats* Section VI.A.7
- *Vegetation-Wetland Habitats* Section III.A.2.g.; Section III.C.2.g.;
Section III.C.3.g.; Section III.D.1.g., 2g., 3g. and 6g.; and Section V.C.7.
- Land Cover Map For the Liberty Mine Site. (October 12, 2000 and supplement dated November 8, 2000) LGL Alaska Research Associates, Inc. Figure II. A-7b and Table III.D-6 of the EIS.

The tundra, onshore pipeline portion of the Liberty Development Project area is characterized by moist to wet tundra expanses of moist sedge and dwarf shrub dominated by *Carex*, *Eriophorium*, and *Salix* spp.(sedges, cotton grass, willow) [NWI classification: PEM1/SS1E] with inclusions of dry tundra. See Tables [Liberty Development Project, Environmental Report, February 1998]: Table 5-2, Vegetation Types at Alternative Liberty Pipeline Landfall and Tie-in Sites and the Kadleroshilik Gravel Mine Site; Table 5-3. Definition of NWI Map Codes; Table 5-5. Summaries of Predominate NWI Wetland Types at Alternative Liberty Pipeline Landfall and Tie-in Sites and Gravel Mine Site, and; Table 5-6. Estimated Vegetation Coverage by On-shore Liberty Pipeline Trench and Gravel Pads. Approximately 1.7 acres of wetlands would be lost due to placement of fill for the two gravel pads and trench backfill operations.

The proposed Kadleroshilik gravel mine site lies approximately 1.4 miles south of Foggy Island Bay on a partially vegetated gravel island in the Kadleroshilik River floodplain consisting of Riverine barrens and flood plain alluvium with a ground surface elevation of approximately six to ten feet above MSL. See Figure II-A-7b of the EIS. The 37.9 acre primary mine site is covered by 40% dry dwarf shrub/lichen tundra (15.1 ac); 20% dry barren/dwarf shrub, forb grass complexes (7.6 ac); 10% dry barren forb complexes (3.8 ac); and, 30% river gravels (11.4 acres). The entire Kadleroshilik mine site (primary mine site plus reserve mine site/staging area) consists of approximately 52 acres. Surface cover consists of ~43% dry dwarf shrub/lichen tundra (19.4 ac); 23% dry barren/dwarf shrub, forb grass complexes (10.5 ac); 9% dry barren for complexes (3.8 ac); and, 25% river gravels (11.4 acres). The National Wetland Inventory Map indicate that of 70 % to 80 % of the NWI wetlands at the site are classified as PEM1/SS1A (Palustrine System Emergent /scrub shrub vegetation seasonally to infrequently flooded); and, 20 % to 30% R2US/OW (Riverine System/open water) partially vegetated gravel bars above the active river channel with gravel substrate) infrequently to seasonally flooded during spring break-up to completely barren river gravels with sparse vegetation. Although the area is classified as



wetlands under NWI, they are not all jurisdictional wetlands under the Corps regulatory program. Barren areas or sparse gravel bars are not considered wetlands; however, areas that are seasonally flooded for sufficient duration and frequency (considered below the ordinary high water mark) would be regulated as waters of the U.S. In addition, there are times where salt-water intrusion may invade the river up to the proposed mine site. Portions of the PEM1 classification although predominately well drained gravel/soils may contain inclusions of jurisdictional wetlands. The estimated wetland loss for the Kadleroshilik Mine Site would be the result from excavation. Wetland losses could occur along the fringes of the mine site for rehabilitation efforts and would be offset by the wetlands and shore habitat gain through mine site rehabilitation.

The designed excavation footprint for the mine site is approximately 31 acres in size (EIS Figure II.A-7b), with the primary excavation area developed as two cells. One cell will be developed each winter construction season. The Phase 1 cell will be approximately 19 acres to support gravel island construction (EIS Table III.D-6) of which 12.7 acres may be wetlands. The Phase 2 cell will be approximately 12 acres of which 11.5 acres may be wetlands. In preparation for mining, snow, ice, and unusable overburden (organic and inorganic materials) will be removed from the mine site. For Cell 1, up to 100,000 cubic yards of overburden would be temporarily stockpiled on a 5-acre portion of the Cell 2 mine area just south of Cell 1. Cell 2 overburden (up to 13,000 cubic yards) plus about 2,500 cubic yards of excess spoil from the onshore pipeline transition trench would either be directly placed into the Cell 1 pit, or on an ice pad in a temporary stockpile area (about 0.5 acres) located just south of the Cell 2 pit.

Mining would not extend into the active river channel; a dike approximately 50 feet wide would be left in place between the mine site and the river channel while mining operations are underway. Gravel would be excavated by blasting, ripping and removing materials in two 20-foot lifts, to a total depth 40± feet below the ground surface. Some portion of the lower 20-foot lift may be left in place if all gravel available from the site is not needed to meet island requirements.

After useable gravel has been removed from the mine, materials unsuitable for construction (e.g. unusable materials stockpiled during mining) would be placed back into the mine excavation. Stockpiled snow and ice would also be pushed back into the pit to minimize effects on natural drainage patterns during spring breakup. These backfilled materials would be used to create a shelf (approximately mean water level) along one side of the mine to improve future habitat potential (littoral zone/wetland). The access ramp down into the mine would form the foundation of the constructed shelf, maximizing new surface area created. To complete construction, the adjacent edge of the pit would be beveled back a distance of 10-20 feet, creating a gradual slope to the shelf. The backfilled area would provide substrate and nutrients to support revegetation and improve future habitat potential of the constructed shelf along the mine wall.

After Phase I mining is complete, the dike between the mined site and the active channel of the Kadleroshilik River would be breached to approximately 6 inches below mean low water in the channel. During spring breakup, the mine site would flood with fresh water, forming a deep lake adjacent to the river. To avoid stranding fish in the lake during periods of low water, a short section of the breach will be lowered to match the river bottom level. Development of the Phase 2 cell is expected to begin the following year to support construction of the offshore pipeline, the shoreline transition, and pipeline valve pads. The Phase 2 mine would disturb approximately 12 acres, to provide the estimated volume of gravel needed for pipeline and pad construction. An approximately 15-foot wide dike will be left between the two cells until mining has been completed.



Mining and rehabilitation plans for Phase 2 would be similar to those described above for Phase 1. After Phase 2 mining is completed, the dike separating the two mine cells will be breached, expanding the original flooded site to create a larger lake. Some portion of the breach would be at least as low as the river bottom, again, to avoid stranding fish during periods of low water. Backfill (e.g. materials stockpiled during Phase 2 mining and excess material from onshore pipeline construction) would be used to enhance the shallow area created during Phase 1 to improve fish habitat potential of that site and should result in an increase in emergent and submergent wetlands. Remnants of the dike between Phase I and Phase II cells would form islands (0.4± acres) in the deep lake, diversifying the aquatic habitat. The shelves constructed along the side of the mine (estimated to be 0.5 - 2.0 acres total) should evolve into shallow water habitat over time in conjunction with flooding the mine site. After a thaw season, it is expected that irregular settlement of the material comprising the shelf will create a surface mosaic of small shallow ponds, humps, and flats.

Based on data collected during 1998 and conditions found during Phase 1 mining, BPXA will prepare a detailed rehabilitation plan, based on final characterization of the site (e.g., post construction topography, microtopography, hydrology and drainage, salinity, surface soil type, and local vegetation).

Upon completion of gravel removal and gravel contouring of the pit, the revegetation portion of the plan would be implemented to encourage revegetation of the shelf areas. Depending on the extent and pattern of thaw settlement, the areas would be seeded, likely with a combination of salt tolerant (and disturbance tolerant) seed stock, as well as other seed stock, as conditions dictate. Depending on access to appropriate sites, ambient moisture and salinity (both current and predicted), some plugging and/or sprigging could also be done.

2.	Sanctuaries and refuges	N/A	<input type="checkbox"/>	<input type="checkbox"/>	<input checked="" type="checkbox"/>
3.	Mud Flats		<input type="checkbox"/>	<input type="checkbox"/>	<input checked="" type="checkbox"/>
4.	Vegetated Shallows		<input type="checkbox"/>	<input type="checkbox"/>	<input checked="" type="checkbox"/>
5.	Coral reefs	N/A	<input type="checkbox"/>	<input type="checkbox"/>	<input checked="" type="checkbox"/>
6.	Rifle and pool complexes	N/A	<input type="checkbox"/>	<input type="checkbox"/>	<input checked="" type="checkbox"/>

d. Potential Effects on Human Use Characteristics (Subpart F)

Section V. B. *Description of Social Environment* [Base condition]

Significant	Not Significant	N/A
-------------	-----------------	-----

1.	Effects on municipal and private water supplies	No affects	<input type="checkbox"/>	<input type="checkbox"/>	<input checked="" type="checkbox"/>
----	---	------------	--------------------------	--------------------------	-------------------------------------

2.	Recreational and Commercial fishing impacts (including subsistence fishing)		<input type="checkbox"/>	<input checked="" type="checkbox"/>	<input type="checkbox"/>
----	---	--	--------------------------	-------------------------------------	--------------------------

No appreciable sport, commercial or subsistence fishing occurs in Foggy Island Bay during the winter. No impacts are anticipated.



During the open water season limited sport fishing occurs on the Alaska North Slope. Oil workers fish for Arctic grayling in old gravel pits that have been rehabilitated to support fish. Occasional fishing for char occurs in major rivers and streams. Commercial fishing on the Alaskan North Slope coastline is limited to one small, family-owned gill net fishery in the Colville River delta. Arctic cisco, least cisco, and broad whitefish are the primary species caught. The commercial catch is sold for human consumption and dog food in Fairbanks and Barrow. Kaktovik and Nuiqsut are the two nearest villages and are greater than 75 miles away from the project area. Nuiqsut harvested 90,490 pounds and Kaktovik harvest 22,952 usable pounds of fish during a three-year period. No effects to subsistence resources are anticipated as a result of the placement of fill material.

3. Effects on water-related recreation	<input type="checkbox"/>	<input type="checkbox"/>	<input checked="" type="checkbox"/>
--	--------------------------	--------------------------	-------------------------------------

4. Aesthetics	<input type="checkbox"/>	<input checked="" type="checkbox"/>	<input type="checkbox"/>
---------------	--------------------------	-------------------------------------	--------------------------

The Arctic Coastal Plain is treeless, low relief landscape dominated by numerous lakes and ponds and low-lying vegetation. The terrain is frozen and covered by ice and snow during the Arctic winter, which typically lasts more than 9 months with 56 days where the sun does not rise above the horizon. During the brief summer of continuous daylight (June through August), ponds, rivers, low-lying shrubs, wildflowers, birds, caribou, small mammals, and insects are noticeable features of the landscape. The nearshore area of the Beaufort Sea changes considerably in appearance from winter to summer. During the winter, the nearshore area freezes and snow and ice drift over the low elevation barrier islands, making them difficult to differentiate from the shoreline and from sea ice.

Aesthetic and visual impacts resulting from the placement of fill material are considered minor. However the level of impact is variable and subjective depending on the viewers sensitivity. No impact would occur due to trench backfill since it would be covered by water. The shoreline transition zone (where the pipeline leaves the ocean to go onshore), the valve and Badami Tie-in pad would be an alteration of the surrounding tundra area. This area has been leased for oil development from the Alaska Department of Natural Resources. Due to the remote locations and because the gravel pads would be infrequently, visual impacts are consider minor.

5. Effects on parks, national and historic monuments, national seashores, wilderness areas, research sites , and similar preserves	No affects	<input type="checkbox"/>	<input type="checkbox"/>	<input checked="" type="checkbox"/>
--	------------	--------------------------	--------------------------	-------------------------------------



V. Evaluation of Dredged or Fill Material
(Subpart G, 40 CFR § 230.60)

- a. The following information has been considered in evaluating the biological availability of possible contaminants in dredged or fill material: (checked boxes apply)
1. Physical characteristics
 2. Hydrography in relation to known or anticipated sources of contaminants
 3. Results from previous testing of the material or similar material in the vicinity of the project
 4. Known, significant, sources of persistent pesticides from land runoff or percolation
 5. Spill records for petroleum products or designated (§311 of CWA) hazardous substances
 6. Other public records of significant introduction of contaminants from industry, municipalities or other sources
 7. Known existence of substantial material deposits of substances which could be released in harmful quantities to the aquatic environment by man-induced discharge activities
- b. An evaluation of the information above indicates that the proposed dredged or fill material is not a carrier of contaminants, or that levels of contaminants are substantively similar at extraction and disposal sites. The material meets the testing exclusion criteria.
- Yes
 No



VI. Disposal Site Delineation
40 CFR §230.11(f)

a. The following factors as appropriate, have been considered in evaluating the disposal site.

- | | |
|--|-------------------------------------|
| 1. Depth of water at the disposal site | <input checked="" type="checkbox"/> |
| 2. Current velocity, direction, and variability at disposal site | <input checked="" type="checkbox"/> |
| 3. Degree of turbulence | <input checked="" type="checkbox"/> |
| 4. Water column stratification | <input checked="" type="checkbox"/> |
| 5. Discharge vessel speed and direction | <input type="checkbox"/> |
| 6. Rate of discharge | <input checked="" type="checkbox"/> |
| 7. Dredged material characteristics | <input checked="" type="checkbox"/> |
| 8. Other factor affecting rates and patterns of mixing | <input checked="" type="checkbox"/> |
| • Placement of fill material during ice cover, through an open trench in the ice cover | |

c. An evaluation of the appropriate factors in V. a. above indicates that the disposal site and/or size of mixing zone are acceptable **Yes**
 No

[Note: Dispersion of very fine to silty fill material will occur outside designated placement areas. This widespread dispersion (0.6 – 2.0 statute miles) would occur by natural means and would result in a thin layer (up to 1-2 mm) dispersion outside the placement area.]

VII. Actions to Minimize Adverse Effects
(Subpart H, 40 CFR § 230.70)

All appropriate and practicable steps would be taken, through application of recommendation of §230.70 – 230.77 to ensure minimal adverse effects of the proposed discharge. **Yes** **No**
Mitigative Measures To Be Determined

Actions taken: (Preliminary)

- Appendix B, Liberty Unit Lease Stipulation summaries and applicable Alaska Regulations.
- Mitigation measures proposed by applicant, as stated in the DA public notice for 6-981109.
- Others to be determined, including consideration of potential mitigation measures identified in Table I-2 of the EIS.

Actions to be taken

- Permit stipulation and conditions would be developed and incorporated in the DA permit, as appropriate. Such as, to validate the predictive assessment to the Boulder Patch community the Corps could require BPXA to prepare and implement a detailed monitoring plan for both the dredging and placement of fill material for the pipeline system construction (TSS, BOD, COD, turbidity, sediment plume magnitude, duration, etc. at multiple water depths.



VIII. Findings of Compliance or Non-compliance
(40 CFR§ 230.12)

[TO BE DETERMINED]

- a. The proposed disposal site for discharge of dredged or fill material complies with the Section 404(b)(1) guidelines

- b. The proposed disposal site for discharge of dredged or fill material complies with the Section 404(b)(1) guidelines with the inclusion of the following conditions: (to be determined if selected)

- c. The proposed disposal site for discharge of dredged or fill material does not comply with the Section 404(b)(1) guidelines for the following reasons:
 - 1. There is a less damaging practicable alternative

 - 2. The proposed discharge will result in significant degradation of the aquatic ecosystem

 - 3. The proposed discharge does not include all practicable and appropriate measures to minimize potential harm to the aquatic ecosystem

 - 4. There does not exist sufficient information to make a reasonable judgement as to whether the proposed discharge will comply with these Guidelines.



References

Ban, Suzanne, J. Colonell, K. Dunton, B. Gallowy, and L. Martin. *Liberty Development: Construction Effects on Boulder Patch Kelp Production*. May 1999.

BP Exploration (Alaska) Inc. *Liberty Development Project, Environmental Report*. Anchorage: BPXA, 1998.

BP Exploration (Alaska) Inc. *Liberty Development Project, Letter Report*. Anchorage: BPXA, January 2000. (Responding to comments raised in the Arctic Biological Task Force meeting on August 31, 1999)

United States. Department of Interior. Minerals Management Service (USDOI, MMS). *Final Environmental Impact Statement, Beaufort Sea Planning Area, Oil and Gas Lease Sale Area 144*. Volume 1. Cooperating Agency: U.S. Environmental Protection Agency, Region 10. OCS EIS/EA MMS 96-0012.N.p.: USDOI, 1996.

United States. Army Corps of Engineers, Alaska District. *Final Environmental Impact Statement, Beaufort Sea Oil and Gas Development/Northstar Project*. Volumes II and III., February 1999.

United States. Army Corps of Engineers, Alaska District, and Environmental Research & Technology, Inc. (USACE and ERT). *Endicott Development Project: Final Environmental Impact Statement*. Vol. 2. Anchorage: USACE, 1984.

URS Greiner Woodward Clyde. Section 103 Marine Protection Research and Sanctuaries Act, Dredged Material Disposal Site Evaluation, In Support of the Liberty Development Project US Army Corps of Engineers Permit Application. Prepared for BP Exploration (Alaska) Inc. November 1998.



Figures

Stratigraphic Cross -Section of Pipeline Routes

Figure 1.

Stratigraphic Cross-Section Preferred Offshore Pipeline Alignment

Legend:

Percent Silt and Clay (Fines) displayed on cross-section.

Vertical Exaggeration is 100:1. Distances in feet.

Preferred pipeline alignment coincides with 1988 Transect D bore holes, 1997 Survey Transect B bore holes projected onto Transect D.

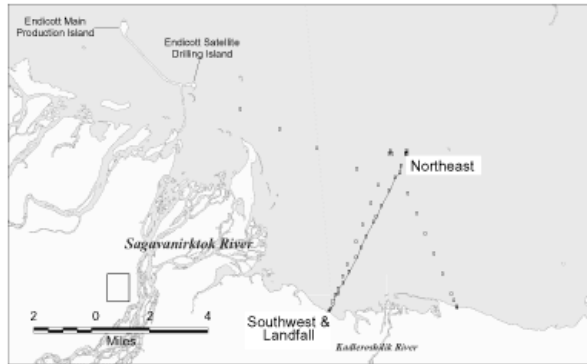
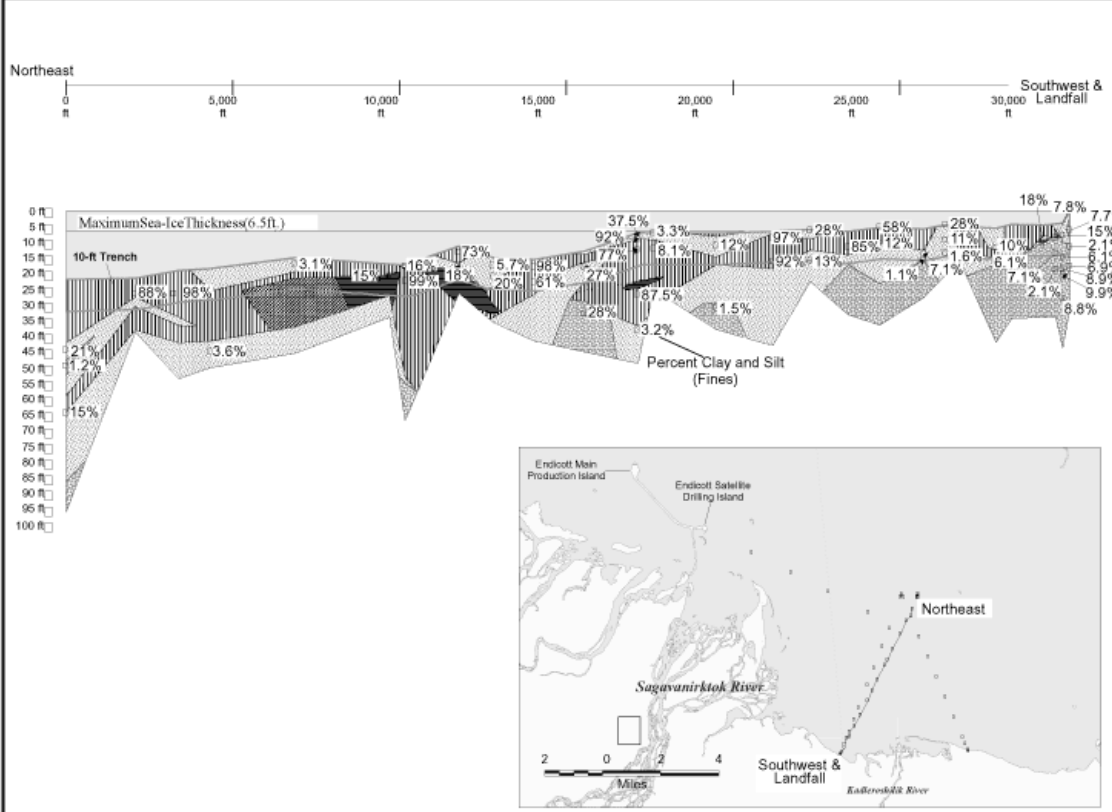
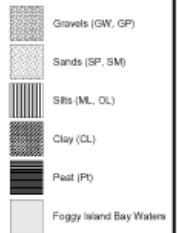

Source: URS Corporation 2000, Liberty Development: Construction Effects on the Boulder Patch-Additional Studies. August 15, 2000

Proposed Pipeline Alignment			
<i>Stratigraphic Unit</i>	Estimated Trench Volume by Stratigraphic Unit (cubic yards)	Silt and Clay Content (Percent Fines)	Estimated Volume of Silt and Clay (cubic yards)
Silty Sand (SM)	2,445	26%	636
Silty Sand (SM-SP)	20,740	18%	3,650
Peat (Pt)	10,759	45%	4,842
Silty Sand (SM)	17,536	26%	4,559
Silty Sand (SM)	19,637	26%	5,106
Peat (Pt)	5,826	45%	2,622
Silt (ML-OL)	3,813	73%	2,783
Clay (CL)	10,328	95%	9,812
Silty Sand (SM-SP)	8,414	18%	1,515
Silt (ML)	1,002	88%	882
Silt (ML)	70,084	88%	61,674
Silt (ML)	56,850	88%	50,028
Total Excavation (cubic yards)	227,434	65%	148,107

Source: URS Corporation 2000, Liberty Development: Construction Effects on the Boulder Patch-Additional Studies. August 15, 2000

Fig G-1 Stratigraphic Cross-Section of Preferred Offshore Pipeline Alignment

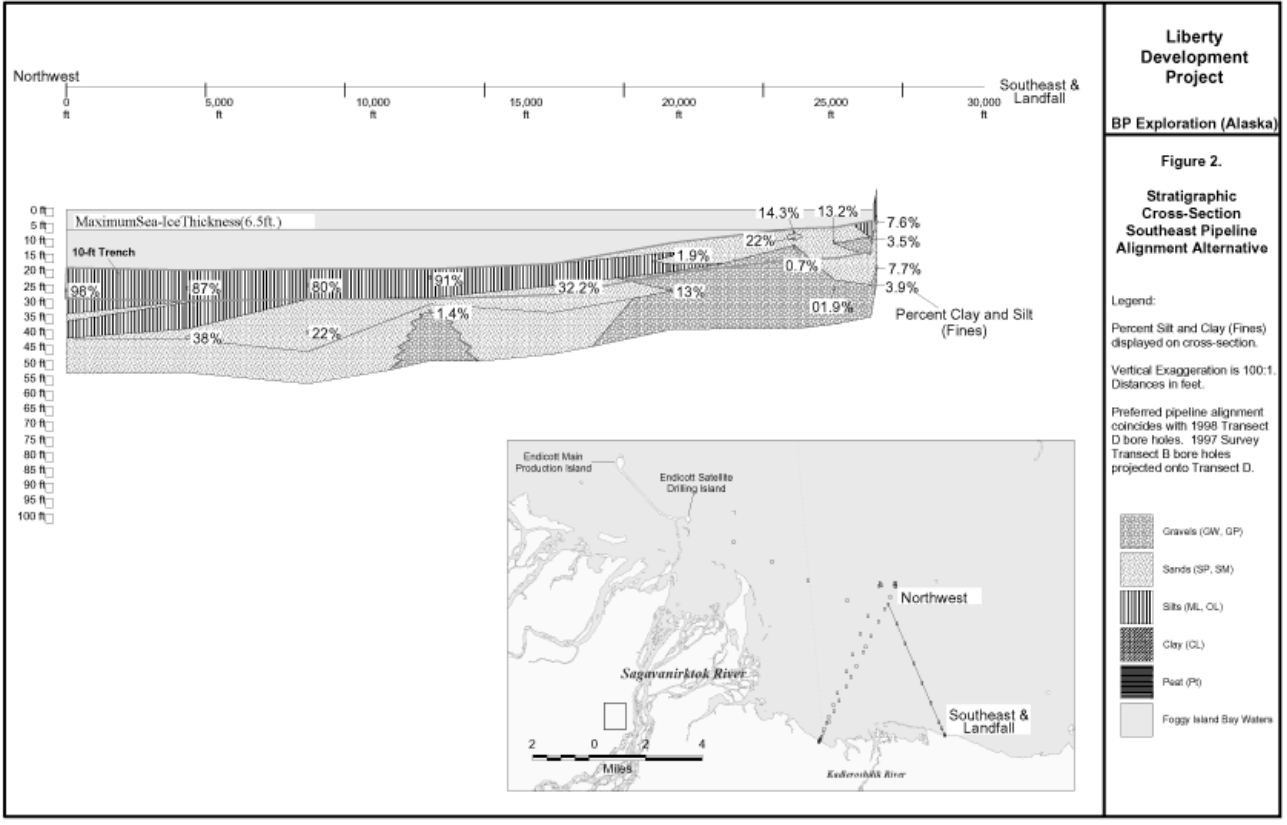

Source: URS Corporation 2000, Liberty Development: Construction Effects on the Boulder Patch-Additional Studies. August 15, 2000

Southeast Pipeline Alignment			
Stratigraphic Unit	Estimated Trench Volume by Stratigraphic Unit (cubic yards)	Silt and Clay Content (Percent Fines)	Estimated Volume of Silt and Clay (cubic yards)
Silt (ML)	177,563	89%	158,031
Silty Sand (SM)	45	26%	12
Silty Sand (SM)	13,558	26%	3,525
Gravel (GP-GW)	9,262	3%	278
Sand (SP)	34,986	2%	700
Silty Sand (SM)	3	26%	1
Total Excavation (cubic yards)	235,417	69%	162,546

Source: URS Corporation 2000, Liberty Development: Construction Effects on the Boulder Patch – Additional Studies. August 15, 2000

Fig G-2 Stratigraphic Cross-Section of Southeast Pipeline Alignment Alternative

ATTACHMENT A
Letter Report - Liberty Development Project
January 17, 2000



6-981109



BP EXPLORATION

BP Exploration (Alaska) Inc.
900 East Benson Boulevard
P.O. Box 106612
Anchorage, Alaska 99519-6612
(907) 561-5111

original to the file

RECEIVED
Anchorage, Alaska

JAN 18 2000

REGIONAL SUPERVISOR
FIELD OPERATION
MINERALS MANAGEMENT SERVICE

January 17, 2000

Mr. Jeff Walker
Regional Supervisor, Field Operations
Alaska OCS Region
U.S. Department of Interior, Minerals Management Service
949 E. 36th Avenue, Room 308
Anchorage, Alaska 99508-4392

Mr. Lloyd Fanter
U.S. Army Corps of Engineers, Alaska District
Regulatory Branch
P.O. Box 898
Anchorage, Alaska 99506-0898

Liberty Development Project

Dear Mr. Walker and Mr. Fanter:

BP Exploration (Alaska) Inc. (BPXA) is transmitting a brief report responding to comments raised in the Arctic Biological Task Force meeting held on August 31, 1999. This report has been prepared by URS Greiner Woodward Clyde in association with LGL Ecological Research Associates and Dr. Kenneth Dunton of the University of Texas at Austin, and relates to agency comments on a report entitled: *Liberty Development: Construction Effects on Boulder Patch Kelp Production*. In the August 31, 1999 meeting BPXA was also requested to explain in detail how Boulder Patch transect map data have been used, this response is still being prepared.

If you have any questions or need additional information, please call Karen Wuestenfeld at 564-5490.

Sincerely,

Peter T. Hanley, Manager Permitting
HSE-Alaska

Attachment

1. INTRODUCTION

1.1. Purpose

The purpose of this report is to respond to comments raised in the Arctic Biological Task Force meeting held on August 31, 1999. That meeting was conducted to present information contained in the report entitled *Liberty Development: Construction Effects on Boulder Patch Kelp Production* (URS Greiner Woodward Clyde et. al. 1999). At the conclusion of that meeting, BP Exploration (Alaska) Inc. (BPXA) agreed to respond to the following comments:

- validate 48-hour exposure assumption (yielding 65% reduction in summer productivity)
- address sedimentation effects on organisms.
- qualitative discussion of effects on community as a whole - not just kelp
- confirm applicability of model given additional knowledge of proposed Northstar (and Liberty) construction sequence
- provide literature reference for 60/40 turbid/clear ice occurrence
- cite wind and current data sources

This document has been prepared by URS Greiner Woodward Clyde in association with LGL Ecological Research Associates and Dr. Kenneth Dunton of the University of Texas at Austin to respond to those comments. It includes a review of previous Boulder Patch studies, a qualitative description of the Boulder Patch community and potential effects of the Liberty project, and a section containing responses to specific issues raised. The Addendum includes corrections to tables presented in URS Greiner Woodward Clyde et al. 1999.

BPXA is responding separately to a request to explain in detail how transect map data were used, and how they fit with previous data mapping efforts.

1.2. Previous Boulder Patch Studies

There have been numerous studies of the Boulder Patch, dating from the discovery of the community in the mid-1970's (Reimnitz and Toimil 1976). The NOAA-OCSEAP Program sponsored most of the investigations of this community from discovery to the early 1980's. From the 1980's to the present, industry-sponsored studies, supplemented by funding from the National Science Foundation, have been prevalent. Boulder Patch studies specifically relating to the Liberty Development were conducted in 1997 and 1998 (*Coastal Frontiers Corporation and LGL Ecological Research Associates, Inc. 1998*) as reported in the *Liberty Development Project Environmental Report* (LGL Ecological Research Associates, Inc., Woodward-Clyde Consultants and Applied Sociocultural Research 1998). These investigations were preceded by the 1984 to 1991 *Endicott Development Baseline and Monitoring Studies* (see Martin and Gallaway 1994 for a review) and the 1982 to 1984 investigations conducted by Harding Lawson Associates for Exxon Corporation in conjunction with the construction of a gravel island (BF-37) in Beechey Point Block 480, Stefansson Sound, Alaska. Harding Lawson Associates also conducted high-resolution benthic surveys of some areas of the Boulder Patch near the Endicott Development in 1980, 1982, and 1984 (Toimil and England 1980. Miller and England 1982, Lee

and Toimil 1985). Synthesis of the early NOAA-OSCEAP studies are highlighted in Dunton et al. (1982), Dunton (1984), and Dunton and Schell (1986).

2. POTENTIAL EFFECTS ON THE BOULDER PATCH COMMUNITY

In our previous reports, we focused on the effects of the Liberty Development Project on kelp productivity *per se*. Herein we provide additional material of the effects of sedimentation/smothering on the larger community. This information supplements that already provided in the *Liberty Development Project Environmental Report* (LGL et al. 1998) and in the report entitled *Liberty Development: Construction Effects on Boulder Patch Kelp Production* (URS Greiner Woodward Clyde et al. 1999).

2.1. Characterization of the Community

The sessile components of the Boulder Patch biota are dominated in terms of biomass by plant species including a brown algae or kelp overstory (47% of the biomass) and a red algae (34%) understory (Figure 1). Young or reproductively immature *Laminaria solidungula* kelp fronds generally range from 22 to 25 cm in total length, with stipes less than 5 cm in length. Reproductively mature plants have fronds 20- to 50-cm long and the stipes are greater than 5 cm in length. The red algae understory includes species such as *Phycodrys rubens*, *Coccotylus (Phyllophora) truncata*, and *Odonthalia dentata*. These are leafy or foliose and terete forms, generally a cm or more in height. The dominant and conspicuous sessile animals include sponges such as *Phakettia cribrosa* (~10 cm in diameter) and *Choanites lutkenii* (~8 cm in diameter); and the soft coral *Gersemia rubiformis* (~8 cm long). At least four species of sea anemones are present, as are stalked hydrozoans and an array of bryozoans. These range in size up to a cm or so in height as well as form a turf-like covering on rocks.

Molluscs, bryozoans, and urochordates are common on rocks and attached to other biota. Interspersed among the sessile plants and animals are motile forms such as the chiton *Amicula vestita*, sea spiders and fish like four-horned sculpin and liparids. Dunton and Schonberg (in press) provide community descriptions that confirm the earlier community characterizations of Dunton et al. (1982).

2.2. Characterization of the Sediment Dynamics

Dunton et al. (1982) provide a characterization of sediment dynamics in the Boulder Patch based on studies conducted from the summer of 1978 through the fall of 1980. One aspect involved quarterly measurement of sediment thickness on biota and on flat trays anchored to the bottom at site DS-11 in summer 1978. Storms in August and September of 1978 were noted to have suspended large amounts of sediments in the water column. When the site was sampled by divers in November 1978, sediment depth on trays and biota ranged between 3 and 5 mm, averaging 4 mm (Figure 6 from Dunton et al. 1982). Considerable sediment was still in suspension limiting diver visibility to <1 m.

During this November effort, the divers noted that the under-ice surface of the thin (~0.5 m-thick) ice canopy was not flat and hard as expected, but was extremely irregular and soft. Considerable sediment was entrapped in this layer, leading the divers to call it "slush" ice or "turbid" ice. This turbid layer had considerable relief (0.5 to 2.5 m), was extremely porous, and was composed of large and small crystals of granular ice individually reaching as much as 5 cm in length. If this slush was disturbed, even by diver's bubbles, sediment entrapped among the ice crystals would rain to the seafloor and water near the disturbance would become turbid. Over the

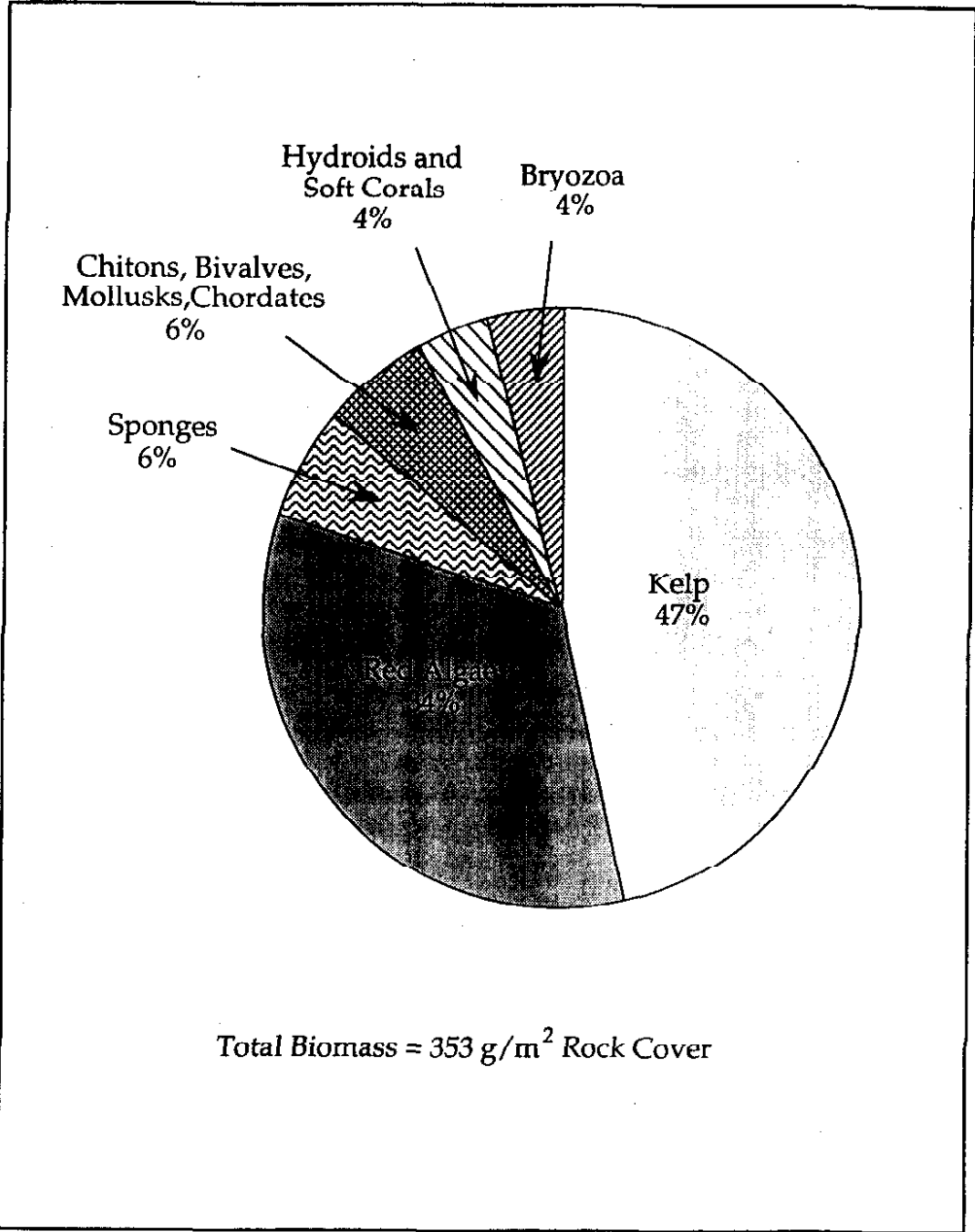

Figure 1. Relative biomass composition by taxon in the Boulder Patch. Data from Table 1 in Dunton et al. 1982. Data also listed in Table 4-2 of the Liberty Development Project Environmental Report.

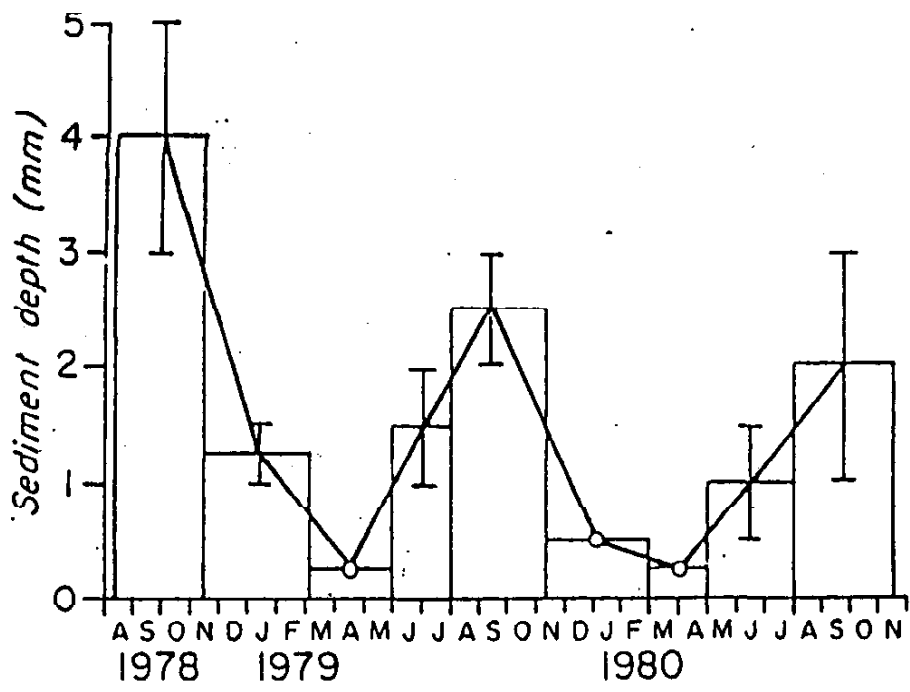

FIG. 6. The pattern of sedimentation at DS-11, as measured seasonally on biota and anchored trays. Vertical bars represent ranges in sediment thickness. Open circles denote values below the limits of precise measurement (<0.5 mm).

From

ARCTIC
VOL. 33, NO. 4 (DECEMBER 1982) P. 465-484

An Arctic Kelp Community in the Alaskan Beaufort Sea

KENNETH H. DUNTON¹, ERK REIMNITZ², and SUSAN SCHONBERG¹

winter, the turbid slush ice was incorporated into the hard congelation ice as freezing advanced downward. By late April, only the longest protrusions were visible under the smooth ice canopy. Dunton et al. (1987) reported that turbid ice was widespread in the vicinity of the Boulder Patch and occurred at DS-11 every year between 1978 and 1982 except in 1981.

By the end of February, sediment thickness on biota and bottom trays had decreased from the 4 mm observed in November to only 1.25 mm; and decreased further to less than 0.5 mm thick by the end of May. The sediment veneer was greatly diminished during winter to spring. In spring (February-May), maximum underwater visibility (>20 m) was noted by the diving scientists indicating that suspended sediment levels were also very low.

By late July of 1979, sediment thickness on the trays increased from the spring low to a layer 1- to 2-mm thick, and water visibility decreased to between 1 and 3 m. By late November, visibility was less than 0.5 m and the sediment layer on the bottom was between 2 and 3 mm thick, the seasonal high for 1979. A similar pattern was evidenced from November 1979 to November 1980 as was described above for November 1978 to November 1979.

Dunton et al. (1982) show that the natural conditions that must be endured by Boulder Patch organisms include being tolerant to periodic sediment veneers up to 5-mm thick during the fall season, as well as periodic blanketing by a sediment layer on the order of 1- to 2-mm thick during summer and winter. Net sedimentation was least during late winter-early spring, a period also characterized by the least amount of suspended sediment. Despite the periodic blanketing of the seafloor by sediments, Dunton et al. (1982) concluded that the Boulder Patch region was a non-depositional environment overall; i.e., sediments did not steadily accumulate on biota and boulders. Observations on stakes driven into consolidated mud and repeated photography of a cobble with an attached kelp showed the area to be, in fact, erosional in overall character. Sedimentation on the organisms can be viewed as a series of episodic suspension and settling events with the deposited sediments removed from the biota by currents between events.

2.3. Potential Effects from the Liberty Development Project

The potential effects from the sedimentation events like described above, in combination with effects from the Liberty Development, include smothering from increased deposition and impairment of feeding by increased suspended sediment levels. The community is resistant to smothering because the vertical profile of the characteristic organisms, at least at mature sizes, is on the order of centimeters whereas the maximum deposition appears to be on the order of millimeters. Deposition of sediment blankets up to 5-mm thick occurs naturally, but most sediment settling events are less severe (e.g., 1- to 3- mm-thick depositions). Even the maximum sediment accumulations are cleaned by currents from the rocks and epilithic organisms in Boulder Patch environments in relatively short order. Smothering of larval recruits, however, may be one of the main reasons contributing to the slow rate of recolonization or colonization of bare substrates that have been observed for this community (Dunton et al. 1982, Martin and Gallaway 1994).

Most of the animal components of the Boulder Patch are suspension feeders. Increased levels of suspended sediments could affect feeding efficiency. However, most of the filter feeders have

either the ability to contract or self-clean during periods characterized by high levels of suspended sediments. Their presence and demonstrated ability to flourish under the natural sedimentary regime suggests they can likely contend with the short-term perturbations induced by the Liberty Development. This premise is also supported by field investigations as described below.

Two monitoring studies of offshore development effects on the Boulder Patch community have been conducted in Stefansson Sound. The first involved determination of the effects of the construction of a gravel island (BF-37) in 1981. The island was constructed during March and April 1981. Divers made qualitative and quantitative observations of the biota and seabed prior to island construction in March, during construction in March, and after construction in May, July, and August. Numerous soft corals (*Gersemia rubiformus*) and kelp plants located near each sampling transect were tagged in the preconstruction period and reexamined throughout the subsequent monitoring period.

Few distinct changes were detected between pre-construction dives in March and dives made in May (Toimil and England 1982). Only at one of the 13 sites investigated, NW-1, was the accumulation of sediments after construction conspicuous to the divers. Here, a 3-mm thick coating of silt blanketed everything exposed on the seabed. This site, 82 m northwest of the island shoreline, had 10 to 15% rock cover containing a diverse fauna and flora, including an abundance of soft coral and kelp. The soft corals showed no effect from exposure to the amounts of siltation observed, even at sites closest to the island.

In a special dive to the gravel slip face of the island during its construction, a soft coral was found within 2 m of the contact between the slip face and the natural substrate. A 5- to 10-mm blanket of silt covered all materials around it, yet the animal was in the fully extended feeding position. Toimil and England (1982) concluded that soft corals, which they characterized as "delicate", appeared to be able to withstand at least a temporary period of siltation of the magnitude associated with the construction of BF-37. The short term effect of the island construction was considered to have been confined to the loss of habitat beneath the island's perimeter.

Additional studies were conducted at this site two years later in March 1983 (Toimil and Dunton 1983). The results suggested that the flora and fauna of the Boulder Patch communities adjacent to the island had not been affected by sedimentation, but that the kelp *Laminaria solidungula* exhibited a significant reduction in linear growth to 70 m downdrift of the island as compared to kelp growth in other areas. However, given that no significant decreases in either the diversity or numbers of organisms surrounding the island were observed, the overall condition of the biological community was considered "good" (Toimil and Dunton 1983). Suspension feeders (soft corals, hydroids, sea anemones, etc.) appeared healthy. Dispersal of slope protection materials and deep drift ice rubble from the island were identified as potential sources of impacts.

The next studies were conducted in August-November 1983 (Toimil and Dunton 1983). Kelp growth studies showed significantly reduced growth occurred out to at least 365 m downdrift of the island, but that the plants were generally healthy at all sites. Deteriorated slope protection materials (DSPM) noted in March 1983 were observed to accumulate in kelp communities which acted as traps for these materials. Sessile filter feeders of the community were not adversely

affected by the DSPM when the fibrous material was observed in physical contact with, but not covering, the animal. However, when covered by these materials, mortality was observed.

Briggs et al. (1985) provide the results of the last year of BF-37 studies, work conducted in August and September of 1984. No reduction in growth was observed for any site and the plants were again indicated to have been healthy at all sites based on tissue density and carbon content. Thus, the main effect of construction of this island immediately adjacent to Boulder Patch habitat was limited to a one season reduction in kelp growth. There were no apparent adverse effects on the community as a whole even though patches of this community were present in the immediate vicinity of the island.

The second study was the Boulder Patch monitoring Program conducted in association with the Endicott Development Project (Martin and Gallaway 1994). Effects of this development on underwater irradiance, kelp growth, kelp health, community structure and diversity, and colonization patterns were evaluated using a before-after control minus impact or BACI model. The results showed that differences between impact and control sites for all the response variables were the same (or less) after construction and six years of operation of the development as they had been before the causeway was developed. If adverse effects had occurred, an increase in the difference in response variables would have been expected. The results were interpreted to mean that there were no adverse effects from the development on kelp or the Boulder Patch community as a whole. The authors offered two alternative explanations for the findings with one being that effects may have occurred, but the controls might have been also affected by the project and were not truly controls. The other alternative was that even the impact stations were not affected as had been predicted. The authors favored the latter explanation based on the observations that actual discharges were far less than predicted, the planned channel dredging did not occur, and that near field soft-bottom benthic studies showed that effects on this community were restricted to an area less than 500-m away from the development, far short of the distance to the nearest Boulder Patch habitat.

2.4. Summary

The results of the above studies combined with the nature of the Liberty Development Project suggest that there will be little or no adverse effects on the Boulder Patch community.

3. RESPONSE TO SPECIFIC COMMENTS

3.1. Explain Basis For Assumption For 65% Reduction In Kelp Growth

The assessment provides a decidedly conservative estimate (65% reduction) of the effects of summer pipeline construction on annual Boulder Patch kelp productivity. The underlying assumptions are that 1) baseline ambient light would be at H_{sat} levels during the entire construction period; 2) the 20 mg/L excess TSS (or the amount of TSS above ambient) sediment plume "envelope" would persist over the composite area for 48-hours; 3) 20 mg/L excess TSS would be sufficient to decrease light below the H_{sat} level; and 4) without the project, only 74 hours of H_{sat} light levels would have been received over the entire year. Under these conditions, productivity would be reduced by 65% as outlined in the assessment.

We did not consider this combination of events very likely, but chose to make the estimate extremely conservative; i.e., "it could happen". Based on the above extremely conservative assumptions, the summer pipeline construction scenario resulted in a 13% decrease in kelp productivity over a single growth season. The message is not that a 13% reduction would actually occur, but that the likelihood of adverse effects is greater for summer pipeline construction as compared to the situation if the same activity was conducted during winter.

3.2. Explain Basis for Assumption of 60% Frequency of Turbid Ice Cover

The basis for this assumption was derived from the maximum underwater irradiance data reported as Photo Flux Fluence Rates (PFFR) in Table 1 of Dunton (1990). The data reflect light conditions under the ice as measured continuously at seven sites in the Boulder Patch during the 1 March to 15 May period for three consecutive years 1987-1989. The continuous records were integrated over 3-hour intervals, yielding a total of 608 discrete observations. Maximum PFFR values = $1.0 \mu\text{mol m}^{-2}\text{s}^{-1}$ were considered to indicate the presence of turbid ice; higher values were considered to reflect the presence of relatively clear ice. Data were not obtained for 4 of the 21 time/space cells, reducing their total number of observations to 17 cells. Of these, 10 observations were less than $1.0 \mu\text{mol m}^{-2}\text{s}^{-1}$ (range was 0.1 to $0.7 \mu\text{mol m}^{-2}\text{s}^{-1}$) indicating that turbid ice was present. Thus, 58.8% (10 of 17) of the time/space cell observations were characterized by turbid ice. We rounded this to 60%. Maximum PFFR values for the remaining time/space cells considered to have clear ice ranged from 1.2 to $5.4 \mu\text{mol m}^{-2}\text{s}^{-1}$.

Dunton et al. (1992) updated the above with additional 1 March-15 May irradiance data obtained at the same seven sites in 1990 and 1991. This increased the total sample size to 30 time/space cells. In this analysis, the results were reported as mean PFFR values rather than as the maximum observed (see Figure 6 in Dunton et al. 1992). In this analysis, data for 12 of the 30 time/space cells (40%) reflected mean values of 0.35 to as high as about $2.25 \mu\text{mol m}^{-2}\text{s}^{-1}$ suggesting clear ice was present at these sites. Mean PFFR at the remaining 60% of the sites did not exceed about $0.2 \mu\text{mol m}^{-2}\text{s}^{-1}$, suggesting turbid ice was present at these locations.

The available data suggest a 60/40 ratio of turbid to clear ice cover is reasonable. However, the available data are essentially transect data which were not collected to specifically address this issue. Because the data are from transects as opposed to being randomly selected locations, their representativeness of the Boulder Patch as a whole is uncertain. Nevertheless, since sediment

Table 1. Average and maximum underwater irradiance (photon-flux fluence rate, PFFR, $\mu\text{mol m}^{-2}\text{s}^{-1}$) at seven sites from 1 March to 15 May in 1987, 1988 and 1989; $n=608$. nd: no data

Site	Mean PFFR			Max. PFFR		
	1987	1988	1989	1987	1988	1989
W1	0.075	nd	0.082	0.4	nd	0.4
W2	0.001	0.859	0.092	<0.1	3.5	0.5
W3	nd	0.165	0.014	nd	0.8	0.1
E1	0.183	nd	0.098	1.2	nd	0.5
E2	0.703	1.076	0.048	3.6	4.2	0.2
E3	nd	1.191	0.439	nd	5.4	2.4
DS11	0.153	0.567	0.033	0.7	2.6	0.2

From

Marine Biology 106, 297-304 (1990)

Marine
Biology
Springer-Verlag 1990

**Growth and production in *Laminaria solidungula*:
relation to continuous underwater light levels in the Alaskan High Arctic ***

K. H. Dunton

Marine Science Institute, The University of Texas at Austin, Port Aransas, Texas 78373-1267, USA

Date of final manuscript acceptance: April 17, 1990. Communicated by J. M. Lawrence, Tampa

WINTER ICE-COVERED
(1 March - 15 May)

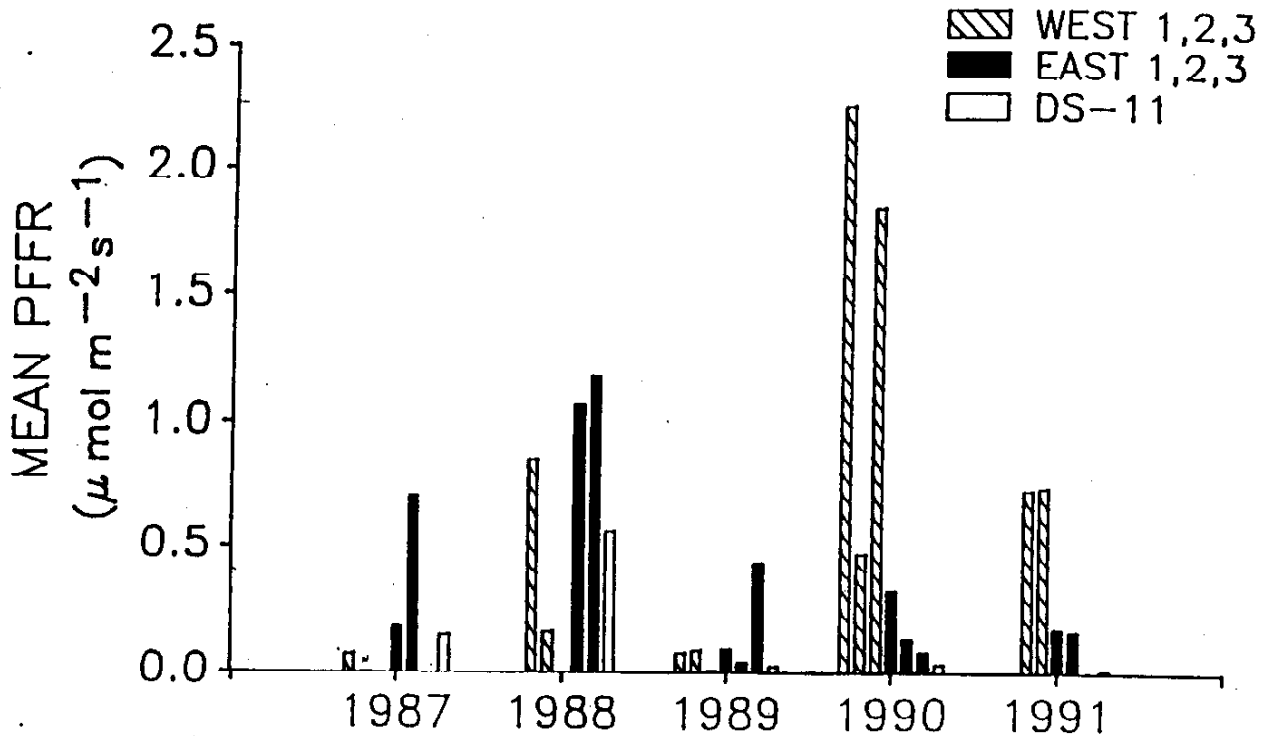

Fig. 6. Variation in mean under-ice PFFR at seven sites from 1 March to 15 May 1987-1991. Data for E-2 in 1991 reflects period from 1 March to 10 April.

From

In: Cahoon, L.B. (ed.). *Diving for Science... 1992*. Proceedings of the Twelfth Annual Scientific Diving Symposium. American Academy of Underwater Sciences. pp. 83-92.

SEASONAL AND ANNUAL VARIATIONS IN THE UNDERWATER LIGHT ENVIRONMENT OF AN ARCTIC KELP COMMUNITY

Kenneth H. Dunton

Susan V. Schonberg

The University of Texas at Austin

Marine Science Institute

P.O. Box 1267

Port Aransas, TEXAS 78373 U.S.A.

Larry R. Martin

LGL Ecological Research Associates

1410 Cavitt Street

Bryan, TEXAS 77801 U.S.A.

George S. Mueller

Water Research Center

University of Alaska

Fairbanks, ALASKA 99775 U.S.A.

entrapment in the ice cover is a regional-scale phenomenon associated with fall storms, common sense dictates that turbid ice would be more widespread and prevalent than clear ice.

3.3. Sources and Use of Wind and Current Data in Analysis

Meteorologic and Oceanographic Data Sources

The nearshore Beaufort Sea has been intensively studied for the past two decades. Numerous authors have been reporting essentially the same results from a plethora of oceanographic studies, conducted for a wide variety of purposes. Most of these studies included direct measurements of wind speed and direction or extensive analysis of available meteorological data that were collected concurrently with oceanographic observations.

The majority of available data were collected and analyzed in conjunction with extensive environmental monitoring programs that were stipulated and overseen by the U.S. Army Corps of Engineers Alaska District. Examples of the latter were the *Prudhoe Bay Waterflood Monitoring Program*, conducted from 1981 to 1984 (USACE 1982, 1983, 1984, 1986) and the *Endicott Development Environmental Monitoring Program*, conducted from 1985 to 1990, (USACE 1987, 1990, 1991, 1993, 1994).

Additionally, several environmental baseline studies commissioned by industry also produced substantial amounts of meteorological and oceanographic data. These included *Prudhoe Bay Dock Studies*, 1976-1979 (Grider et al. 1977, 1978; Chin et al. 1979; Chin 1980), *Endicott Development Baseline Studies*, 1981-1982 (Weingartner & Colonell 1982; Britch et al. 1983), *Oliktok Point and Vicinity Baseline Studies*, 1981-1982 (Weingartner & Colonell 1982, 1983), and *Lisburne Environmental Baseline Studies*, 1983-1984 (Berry & Colonell 1983, 1985).

Conclusions drawn from all of these studies, especially with regard to winds and currents along the Beaufort Sea coast, are essentially identical and can be expressed by a relatively short list of statements:

- Winds are persistent, occur on more than 95 percent of the days, and tend to be oriented along the coast (east or west). East winds consistently average about 5 meters/second (m/s) (11 mph) at Barrow and 6 m/s (13 mph) at Kaktovik. The strongest winds, having speeds of as much as 26 m/s (58 mph), are usually from the west.
- Easterlies (i.e. winds from directions between northeast and southeast) tend to be about 2-3 times as prevalent as westerlies (from northwest to southwest)
- Nearshore currents are governed by the wind, are usually aligned with bathymetric contours, in an east-west direction and flow in the same general direction as the prevailing winds.
- Wind-driven currents typically flow at 2-3 percent of the wind speed along the open coast and respond within 2-3 hours to changes in wind speed or direction.

Current Speed and Direction

Current speed data are described and referenced on pages 2-1 and 2-2 of the report entitled *Liberty Development: Construction Effects on Boulder Patch Kelp Production* (URS Greiner Woodward Clyde et al. May 1999). The data and references as presented are: Average during June and July -5cm/s (USACE 1987-1993); average during August to Sept.-14 cm/s (USACE 1987-1993); average under ice <2 cm/s (Montgomery Watson 1997, Berry and Colonell, 1985). Winter current measurements were also obtained by Woodward-Clyde Consultants (1979) at six locations north of the end of West Dock. Mean current speeds for all meters were less than 2 cm/s. There was a dominant peak at a period of approximately 12 hours, suggesting a tidal influence. Data from NORTEC (1981) support these observations.

Regarding current direction, the Boulder Patch Report states (p. 2-5): "Historical data on the circulation of Beaufort Sea coastal waters show that, on average, the currents are westerly 60-70% of the time." In summer, currents are primarily wind driven and oriented parallel to the wind direction, with a velocity about 2 to 3 percent of the wind speed in magnitude (USACE 1982)." The prevailing summer winds along the Beaufort Sea coast are from the east and the nearshore currents respond to this wind stress by flowing westward. NORTEC (1981) states "all westerly winds produce easterly water transport" (referencing a study by Barnes et al., 1977, in water depths of 5.5 m off of the Sagavanirktok River Delta in August 1976).

In winter the Beaufort Sea nearshore currents are generally westerly (LGL et al. 1998). Berry and Colonell (1985) reported that under-ice currents were typically toward the west and parallel with the shore at a station immediately north of the West Dock Seawater Treatment Plant.

For the "shoulder" seasons of autumn freezeup and spring breakup, data are extremely sparse due to the difficulty of ensuring the survivability of current meters under those conditions. Nortec (1981) recovered current meters that had been deployed through the sea ice and left in place until after spring breakup at depths of 5.5 m and 8.2 m near Reindeer Island, some 5 – 7 miles north of Prudhoe Bay. During June and early July, the usual duration of spring breakup, current speeds ranged from near-zero to 0.10 m/s, with a visually estimated mean of about 0.05 m/s.

Use of Current Data in Estimation of Sediment Transport

As explained in Appendix A of the report entitled *Liberty Development: Construction Effects on Boulder Patch Kelp Production* (URS Greiner Woodward Clyde et al. 1999), the transport of suspended sediment due to ambient currents was simply the computation of the distance traveled by sediment particles of a given size while they fell to the seabed. The key assumptions in the analysis were as follows:

- Initial concentration of suspended sediments was uniform throughout the water column, although analysis could actually accommodate any other assumption.
- Horizontal transport was at the mean current speed, which was assumed to be 0.10 m/s in open water, 0.02 m/s under full sea-ice canopy, and 0.05 m/s under broken sea ice.
- Vertical fall velocity of sediment particles was in accord with proven fluid drag relationships, which were (a) Stokes Law for the smallest particles (<0.15 mm diam.), or (b) laminar or turbulent drag formulas, depending on Reynolds number characterization of flow parameters.

- With regard to the veracity of the analytical approach, assumptions regarding the dynamics of sediment transport are in strict accord with proven relationships drawn from the field of fluid mechanics (e.g. see Schlichting 1968 and/or Blevins 1984). Probably the “weak” point of the analysis is the assumption of an initially uniform concentration of suspended sediment. Lacking data to support any other assumption, there was no particular reason to assume otherwise. The monitoring program, proposed to occur during construction of Northstar Development and described in Section 3.4, should provide useful information that will offer the opportunity to refine the assumptions that support this analysis.

3.4. Planned Water Quality Sampling During Northstar Construction

The following information is from “*Excavation Production Tests and Monitoring Program for the Submersible Soil Agitator Pump, Northstar Development* (URS Greiner Woodward Clyde, November, 1999). The goal of the Northstar Development Pipeline Construction Water Quality Monitoring Program is to measure the temporary increases in total suspended sediment (TSS) and turbidity associated with excavation and hydraulic backfill activities from the submerged soil agitator pump (SAPP) system. The monitoring program will consist of water column sampling down current of ongoing excavation activities related to the proposed production test trench program and collection of ambient current velocity from a background station. Results from in-situ water column and discrete water sampling will be compared to predicted TSS concentrations that were derived from a dilution model.

Parameters of Concern

In-situ water column profiles of turbidity will be collected to identify the water depth with the highest measurements. Discrete water samples will be collected for laboratory analysis of TSS and turbidity at the water depth of the highest in-situ turbidity measurement and at regular intervals within the water column.

Field Methods

Background “Ambient” Measurements: A background station will be occupied periodically throughout the monitoring program to collect representative current velocity and ambient water quality (i.e., TSS and turbidity) samples. The background station will be located in similar water depths (greater than 20 feet MLLW), and at a location so that the waters represent natural ambient conditions.

In-situ water column turbidity will be collected on a regular basis (approximately every 8 hours) at the background station. Water samples will be collected prior to the deployment of the current meter to assure that the water samples will not be biased if the current meter deployment disturbs the seafloor, which could result in elevated TSS and turbidity values. Discrete water samples will be collected daily from the background station, with in-situ water quality measurements conducted approximately every 8 hours during the monitoring program.

Construction Monitoring: Once the current direction has been established, a water quality sampling transect will be configured to observe the anticipated maximum concentrations of TSS and turbidity down current of the excavation activities. The first sample station on the transect will be located in the near vicinity of the excavation equipment along the down current side of the ice slot. The suspended sediment “cloud” generated at the excavation site will move down current at the current speed. Thus, the down current sampling stations must be sampled at

predetermined intervals based on current speed and the distance down current from the excavation. At each down current sampling station, an ice auger will drill a hole through the sea ice providing access to the underlying waters. An in-situ water quality meter will measure turbidity throughout the water column and the field team will identify the water depth with the highest turbidity value. Four water samples will be collected with one sample collected at the depth coinciding with the highest in-situ turbidity value. The other samples will be collected at equal intervals throughout the water column. It is anticipated that it will take approximately 24 hours to complete sampling along the transect. The discrete water samples will be shipped for laboratory analysis of TSS and turbidity.

The results of this planned water quality sampling during Northstar Construction can be easily input into the analytical model described in *Liberty Development: Construction Effects on Boulder Patch Kelp Production* (URS Greiner Woodward Clyde et al. 1999). Although a simple vertically uniform initial concentration of suspended sediment was assumed in the original analytical model, the analysis can easily be re-programmed to accommodate virtually any other initial concentration profile. The planned Northstar sampling will include measurement of initial concentration profiles that will enable a field verification of the model, which can then be refined and extrapolated to future construction efforts such as those planned for Liberty.

REFERENCES

- Barnes, P., Reimnitz, E., and Drake, D. 1977. Marine Environmental Problems in the Ice Covered Beaufort Sea Shelf and Coastal Regions. NOAA/OCSEAP Annual Report, R.U. 205, 229 pp.
- Berry, A.D., and J.M. Colonell. 1983. Physical oceanography. Chapter 6. *In*: Lisburne Development Area: 1983 Environmental studies. Prepared by Woodward-Clyde Consultants for ARCO Alaska, Inc. Anchorage, Alaska. 43 p.
- Berry, A.D., and J.M. Colonell. 1985. Prudhoe Bay Waterflood Project Seawater Treatment Plant: Main Outfall Dispersion Study, 9-19. April 1985. Prepared for ARCO Alaska Inc. by Entrix Inc., Anchorage, AK. August 1985.
- Blevins, R.D. 1984. Applied fluid dynamics handbook. Van Nostrand Reinhold Co., New York, NY. 558 p.
- Briggs, S.R., L.J. Toimil, and K.H. Dunton. 1985. 1984 Supplemental study: Environmental effect of gravel island construction, OCS-Y0191 (BF-37) Beechey Point, Block 480 Stefansson Sound, Alaska. Report for Exxon Company USA, Houston TX, by Harding Lawson Associates. 57 p.
- Britch, R.P., R.C. Miller, J.P. Downing, T. Petrillo, and M. Vert. 1983. Volume II physical processes. *In* B.J. Gallaway and R.P. Britch (eds.). Environmental Summer Studies (1982) for the Endicott Development. LGL Alaska Research Associates, Inc. and Harding Technical Services. Report for SOHIO Alaska Petroleum Company, Anchorage, Alaska. 219 pp.
- Chin, H. 1980. Physical/chemical measurements taken in the Beaufort Sea, July/August 1979, data report. *In*: Environmental Studies of the Beaufort Sea: Summer 1979. Prepared by Woodward-Clyde Consultants for the Prudhoe Bay Unit, Anchorage, Alaska. 95 p.
- Chin, H.A., M. Busdosh, G.A. Robilliard, and R.W. Firth. 1979. Environmental studies associated with the Prudhoe Bay Dock—physical oceanography and benthic ecology: the 1978 studies. Final Report. Prepared by Woodward-Clyde Consultants for ARCO Alaska Inc., Anchorage, AK.
- Coastal Frontiers and LGL Ecological Research Associates, Inc. 1998. Liberty Development 1997-98 Boulder Patch Survey. Final Report to DP Exploration (Alaska) Inc., Anchorage, Alaska. 46 p. + Append.
- Dunton, K.H. 1984. An annual carbon budget for an arctic kelp community. *In*: Barnes P., Schell, D., and Reimnitz, E., eds. The Alaska Beaufort Sea ecosystem and environment. Orlando: Academic Press. 311-326.
- Dunton, K.H. 1990. Growth and production in *Laminaria solidungula*: relation to continuous underwater light levels in the Alaskan high arctic. *Marine Biology* 106: 297-304.
- Dunton, K.H., S.V. Schonberg, L.R. Martin, and A.S. Mueller. 1992. Seasonal and annual variations in the underwater light environment of an arctic kelp community. Pp 83-92.

- In Cahoon, L.B. (ed). Proceedings of the Twelfth Annual Scientific Diving Symposium, American Academy of Underwater Sciences.
- Dunton, K.H., and S.V. Schonberg. In Press. The benthic assemblage of the Boulder Patch kelp community. Pages 371-397. In: Truett, J.G., and S.R. Johnson (eds.), *The Natural history of an Arctic Oil Field*. Academic Press.
- Dunton, K.H., E., Reimnitz, and S. Schonberg. 1982. An arctic kelp community in the Alaskan Beaufort Sea. *Arctic* 35:465-484.
- Dunton, K.H., and D.M. Schell. 1986. A seasonal carbon budget for the kelp *Laminaria solidungula* measured *in situ* in the Alaskan high Arctic. *Marine Biology* 98:277-285.
- Grider, G.W., G.A. Robilliard, and R.W. Firth. 1977. Coastal processes and marine benthos, 1976 studies. In: *Environmental Studies associated with the Prudhoe Bay Dock, Final Report*. Prepared by Woodward-Clyde Consultants for Atlantic Richfield Co., Anchorage, Alaska. 151 p. + App.
- Grider, G.W., G.A. Robilliard, and R.W. Firth. 1978. Coastal processes and marine benthos, 1976 studies. In: *Environmental Studies associated with the Prudhoe Bay Dock, Final Report*. Prepared by Woodward-Clyde Consultants for Atlantic Richfield Co., Anchorage, Alaska. 141 p.
- Lee, R.K., and L.J. Toimil. 1985. Distribution of sea-floor boulders in Stefansson Sound, Beaufort Sea, Alaska. Final Report to SOHIO Alaska Petroleum Company. Available at Harding Lawson Associates, P.O. Box 578, Novato, California 94948. 23 p.
- LGL Ecological Research Associates, Inc., Woodward-Clyde Consultants and Applied Sociocultural Research. 1998. Liberty Development Environmental Report. Final Report to BP Exploration (Alaska) Inc., Anchorage, Alaska.
- Martin, L.R., and B.J. Gallaway. 1994. The effects of the Endicott Development project on the Boulder Patch, an Arctic kelp community in Stefansson Sound, Alaska. *Arctic* 47:(1)54-64.
- Miller, D.L., and J.M. England. 1982. Geotechnical engineering considerations, Duck Island Development Project, Beaufort Sea, Alaska. Exxon Company, U.S.A. Unpubl. ms. Available at Harding Lawson Associates, P.O. Box 578, Novato, California 94948. 35 p.
- Montgomery Watson. 1997. Liberty Island route water/sediment sampling. Prepared for BP Exploration (Alaska) Inc., P.O. Box 196612, Anchorage, AK 99519-6612.
- NORTEC 1981. Beaufort Sea drilling effluent disposal study. Prepared for the Reindeer Island stratigraphic test well participants, under direction of Sohio Alaska Petroleum Company by Northern Technical Services, Anchorage, AK, April 1981.
- Reimnitz, E., and L. Toimil. 1976. Diving notes from three Beaufort Sea sites. In: Barnes, P., and Reimnitz, E. Geological processes and hazards of the Beaufort Sea shelf and coastal regions. Unpubl. ms. Available at NOAA Arctic Environmental Assessment Center, Grace Hall, Suite 300, 4230 University Drive, Anchorage, Alaska 99508. Attachment J. 7 p.

- Schlichting, H. 1968. *Boundary-layer Theory*. McGraw-Hill Book Co., NY. 647 p.
- Toimil, L.J., and K.H. Dunton. 1983. Supplemental study: Environmental effect of gravel island construction OCS-Y0191 (BF-37) Beechey Point, Block 480 Stefansson Sound, Alaska. Report for Exxon Company USA, Houston, TX, by Harding Lawson Associates. 56 p + Appen.
- Toimil, L.J., and K.H. Dunton. 1984. Summer 1983 supplemental study: Environmental effect of gravel island construction OCS-Y0191 (BF-37) Beechey Point, Block 480 Stefansson Sound, Alaska. Report for Exxon Company USA, Houston, TX, by Harding Lawson Associates. 37 p + Appen.
- Toimil L.J., and J.M. England. 1980. Investigation of rock habitats and sub-seabed conditions, Beaufort Sea, Alaska. Unpubl. ms. Available at Harding Lawson Associates, P.O. Box 578, Novato, California 94948.
- Toimil, L.J., and J.M. England. 1982. Environmental effects of gravel island construction OCS-Y0191 (BF-37) Beechey Point, Block 480 Stefansson Sound, Alaska. Report for Exxon Company USA, Houston, TX, by Harding Lawson Associates. 61 p.
- URS Greiner Woodward Clyde, LGL Ecological Research Associates, Inc., and K.H. Dunton. 1999. Liberty Development: Construction Effects on Boulder Patch Kelp Production. Prepared for British Petroleum Exploration (Alaska) Inc.
- URS Greiner Woodward Clyde, November 1999. Excavation Production Tests and Monitoring Program for the Submersible Soil Agitator Pump, Northstar Development, the Work Plan. Prepared for BP Exploration (Alaska) Inc.
- U.S. Army Corps of Engineers (USACE). 1982. Prudhoe Bay Waterflood Project Environmental Monitoring Program 1981. Volume 1. Prepared by Woodward-Clyde Consultants for the USACE, Alaska District, Anchorage, AK.
- U.S. Army Corps of Engineers (USACE). 1983. Prudhoe Bay Waterflood Project Environmental Monitoring Program 1982. Volume 1. Prepared by Envirosphere Company for the USACE, Alaska District, Anchorage, AK.
- U.S. Army Corps of Engineers (USACE). 1984. Prudhoe Bay Waterflood Project Environmental monitoring Program 1983. Volume 1. Prepared by Envirosphere Company for the USACE, Alaska District, Anchorage, AK.
- U.S. Army Corps of Engineers (USACE). 1986. Prudhoe Bay Waterflood Project Environmental monitoring Program, 1984 Report. Volume 1. Prepared by Envirosphere Company for the USACE, Alaska District, Anchorage, AK.
- U.S. Army Corps of Engineers (USACE). 1987. 1985 Final Report for the Endicott Monitoring Program, Volume 3, Oceanographic Monitoring. Prepared by Envirosphere Company, Anchorage, AK, for the U.S. Army Corps of Engineers, Alaska District.
- U.S. Army Corps of Engineers. 1990. 1986 Final Report for the Endicott Monitoring Program, Volume 2, Oceanography. Prepared by Envirosphere Company, Anchorage, AK, for the U.S. Army Corps of Engineers, Alaska District.

- U.S. Army Corps of Engineers. 1991. 1987 Final Report for the Endicott Monitoring Program, Volume 2, Oceanography. Prepared by Science Applications International Corporation, Anchorage, AK, for the U.S. Army Corps of Engineers, Alaska District.
- U.S. Army Corps of Engineers. 1992. 1988 Final Report for the Endicott Monitoring Program, Volume 2, Oceanography. Prepared by Science Applications International Corporation, Anchorage, AK, for the U.S. Army Corps of Engineers, Alaska District.
- U.S. Army Corps of Engineers. 1993. 1989 Final Report for the Endicott Monitoring Program, Volume 2, Oceanography. Prepared by Science Applications International Corporation, Anchorage, AK, for the U.S. Army Corps of Engineers, Alaska District.
- U.S. Army Corps of Engineers. 1994. 1990 Final Report for the Endicott Monitoring Program, Volume 2, Oceanography. Prepared by Science Applications International Corporation, Anchorage, AK, for the U.S. Army Corps of Engineers, Alaska District.
- Weingartner and J.M. Colonell. 1983. Oliktok Pt. and Vicinity Environmental Studies, 1982 Report. Prepared for ARCO Alaska Inc.
- Weingartner and J.M. Colonell. 1982, Duck Island Environmental Studies 1981 Report. Prepared for Exxon Company USA.
- Woodward-Clyde 1979. Environmental studies of the Beaufort Sea Winter 1979. Prepared for Prudhoe Bay Unit by Woodward-Clyde Consultants, Anchorage, AK, December 1979.

ATTACHMENT B
Liberty Development: Construction Effects on Boulder
Patch Kelp Production (1999)



6-981109

FINAL REPORT

LIBERTY DEVELOPMENT: CONSTRUCTION EFFECTS ON BOULDER PATCH KELP PRODUCTION

Prepared for

BP Exploration Alaska Inc.
P.O. Box 196612
Anchorage, Alaska 99519-66012
May 27, 1999

by

Suzanne M. Ban¹
Dr. Jack Colonell¹
Dr. Ken Dunton²
Dr. Benny Gallaway³
Larry Martin³

¹ URS Greiner Woodward Clyde
3501 Denali Street, Suite 101
Anchorage, AK 99503

² University of Texas at Austin
Institute of Marine Science
Port Aransas, Texas 78373

³ LGL Ecological Research Associates
1410 Cavitt Street
Bryan, Texas 77801

TABLE OF CONTENTS

Section 1	Introduction	1-1
1.1	Environmental Setting	1-1
1.2	Proposed Construction Plan and Schedule	1-3
1.2.1	Island Construction	1-3
1.2.2	Pipeline Construction.....	1-4
1.3	Construction Activities and Environmental Concerns.....	1-5
1.3.1	Island Construction	1-5
1.3.2	Pipeline Construction.....	1-5
1.3.3	Ocean Disposal of Spoil Piles.....	1-6
Section 2	Introduction of Suspended Sediments by Construction Activity	2-1
2.1	Ambient Conditions.....	2-1
2.1.1	Summer Conditions (Open-Water)	2-1
2.1.2	Winter Conditions (Ice-Covered).....	2-1
2.2	Introduction of Suspended Sediments By Construction Activity	2-2
2.3	Increased Suspended Sediment Due to Construction Activity	2-3
2.3.1	Liberty Island Construction	2-3
2.3.2	Pipeline Construction –Winter or Summer.....	2-5
2.3.3	Ocean Disposal of Stockpiled Material	2-10
2.3.4	Re-Suspension of Stockpiled Materials	2-11
Section 3	Effects of Altered Water Quality on Boulder Patch Kelp	3-1
3.1	Environmental Conditions and Kelp Vitality	3-1
3.1.1	Calculation of Kelp Production Rates.....	3-1
3.1.2	Boulder Patch Map Development.....	3-2
3.2	Effects of Increased TSS On Kelp Productivity	3-3
3.2.1	Assumptions.....	3-3
3.2.2	Effects	3-4
Section 4	Conclusions	4-1
4.1	Summary of Predicted Effects	4-1
4.2	Duration and Extent of Anticipated Effects.....	4-1
Section 5	References.....	1

TABLE OF CONTENTS

List of Tables

Table 2-1	Summary Excess Suspended Sediments Due to Construction Activities	2-4
Table 2-2	Ocean Dumping of Stockpiled Materials — Dimensions and Concentrations	2-10
Table 2-3	Water Depths and Applicable Fetch Distances for Disposal Sites.....	2-13
Table 2-4	Wave Length As a Function of Wind Speed And Fetch	2-13
Table 3 1	Net Reduction Over the Entire Boulder Patch and Estimated Worse Case Reductions In Production Associated With Liberty Development Project Construction Activities.....	3-8
Table 3-2	Net Production Over the Entire Boulder Patch and Estimated Worse Case Reductions In Production Associated With Liberty Development Project Construction Activities, Single Season Option	3-9
Table 3-3	Net Production Over the Entire Boulder Patch and Estimated Worse Case Reductions In Production Associated With Liberty Development Projectconstruction Activities, Summer Pipeline Construction Option.....	3-10
Table 4-1	Summary of Predicted Effects of Construction-Induced Excess Suspended Sediments	4-2
Table 4-2	Summary of Assumptions	4-3

List of Figures

Figure 1-1	Project Location Map	1-2
Figure 2-1	Maximum Exposure to Suspended Solids Resulting from Liberty Island Construction (Winter Conditions).....	2-6
Figure 2-2	Maximum Exposure to Suspended Solids Resulting from Pipeline Construction (Winter Condtions).....	2-8
Figure 2-3	Maximum Exposure to Suspended Solids Resulting from Pipeline Construction (Summer Condtions).....	2-9
Figure 2-4	Maximum Exposure to Suspended Solids Resulting from Ocean Dumping (Breakup Condtions)	2-12
Figure 3-1	Construction Effects Related to Kelp Growth Year	3-7

List of Appendices

Appendix A	Transport of Re-Suspended Sediments
------------	-------------------------------------

EXECUTIVE SUMMARY

BP Exploration (Alaska) Inc. (BPXA) plans to develop the Liberty oil field in the Beaufort Sea from a gravel island to be constructed in Foggy Island Bay. The Liberty development will include a subsea pipeline from the proposed island (Liberty Island) to a land-based connection with the Badami Pipeline System.

Island construction and installation of the pipeline from the mainland to Liberty Island are expected to increase suspended sediment load in the water column. Remaining stockpiled spoils will be released to the water column as the ice melts at breakup and will thereby provide an additional release of suspended sediments to the water column.

Increased suspended sediment concentrations resulting from construction activities, during either open-water or ice-covered periods, are of concern because of they would reduce light penetration into the water column. Kelp beds resident in Boulder Patch areas located to the north and west of Liberty Island could be adversely affected by a reduction in available light. This would likely reduce kelp productivity and, if light reduction persisted over the long-term (>3-5 years), it could affect the entire Boulder Patch flora and fauna community.

For the specific purpose of this assessment, the Boulder Patch habitat (>10% rock cover) was estimated to occupy about 64 km² (15,871 acres) of the seabed near the proposed Liberty Development. Total annual kelp production for this area is calculated as 638 x 10⁶g Carbon per year, which serves as the baseline for estimating effects of project construction.

To determine winter effects of excess suspended sediments (XSS¹), all Boulder Patch habitat beneath projected sediment plumes or clouds, having concentrations greater than 10 mg/l, was assumed to be affected as if it was beneath turbid (opaque) ice cover. For the open-water period, the threshold of total blockage of available light was assumed to occur when XSS concentrations exceeded 20 mg/L. Kelp production rates for each case were reduced in accordance with observations made for similar natural conditions.

For the Base Case, where island construction occurs during the first winter and pipeline construction occurs the following winter, reduction of kelp productivity due to XSS is estimated to be 0.1 percent due to Year 1 construction activities. Pipeline installation activities in Year 2 could reduce annual productivity by about 4 percent. In Year 3, the kelp could experience a 2 percent reduction in productivity during the summer growth season due to sediment disposal from Stockpile Zone 1. These effects are not cumulative but are spread over consecutive growth years, with the reductions ranging from 2 to 4 percent per year.

The single season construction scenario differs from the Base Case in that both Liberty Island and the pipeline would be constructed during the same winter. As before, island construction effects are expected to be very small; so as with the Base Case, winter construction effects could result in about a 4 percent reduction in annual productivity for Year 1, followed by another 2 percent reduction for Year 2 due to dispersal of stockpiled sediments.

An option for summer pipeline construction was also analyzed and determined to affect almost 13 km² of Boulder Patch habitat. The effects of construction-induced XSS could result in a 13

¹ XSS: Excess Suspended Sediment—the amount of TSS above ambient levels

EXECUTIVE SUMMARY

percent reduction in kelp productivity during the second kelp growth season following the beginning of construction activities.

The effects described for all construction scenarios would be temporary and of short duration. However, as low as they are, even these numbers should be regarded as very conservative; that is, they result in an *over-estimate* of effects, due to the compounding of conservative assumptions taken while estimating both physical and biological effects.

1.1 ENVIRONMENTAL SETTING

BP Exploration (Alaska) Inc. (BPXA) plans to develop the Liberty oil field in the Beaufort Sea for production and transport of sales-quality oil to the Trans-Alaska Pipeline System. The field will be developed from a gravel island to be constructed in Foggy Island Bay on a federal Outer Continental Shelf (OCS) lease. The Liberty oil field development will include a subsea pipeline extending from the proposed island (Liberty Island) to a land-based connection with the Badami Pipeline System.

The island site is immediately seaward of the 20-ft isobath (6.1 m) within Foggy Island Bay (Figure 1-1). Foggy Island Bay is a shallow embayment of Stefansson Sound, with shoals evident in nearshore areas. Although the seabed in the immediate vicinity of the Liberty Development is mostly flat and featureless, there are areas in Stefansson Sound nearby where dense ($\geq 25\%$) rock cover provides habitat for unique assemblages of flora and fauna (Reimnitz and Toimil 1976). Isolated patches of this marine life also occur in areas where the rocks are more widely scattered (10 to 25 percent rock cover). These areas of Stefansson Sound containing rocky substrate have been partially mapped and are designated as the "Boulder Patch." The presence of offshore shoals and barrier islands in this portion of Stefansson Sound provides the necessary combination of rocky substrate and sufficient water depth (12-14 ft under sea ice), to protect the Boulder Patch from extensive ice gouging and reworking of the bottom (Dunton and Schonberg 1981). Although boulders up to 2-m across and 1-meter high are sometimes encountered, most of the rock cover occurs in the pebble to cobble size range (2 to 256 mm).

The boulders, and attached dominant kelp species, *Laminaria solidungula*, provide habitat for a large number of invertebrate species. Sponges and cnidarians, including the soft coral *Gersemia rubiformis*, are among the most abundant of the sessile invertebrates growing on the rock substrate. Approximately 98 percent of the carbon produced annually in the Boulder Patch is derived from kelp and phytoplankton. *Laminaria* is estimated to contribute 50 to 56 percent of the annual production depending on whether the plants are beneath clear or turbid ice (Dunton 1984).

Remote sensing and limited video photographic ground-truth data collection during the 1997 Boulder Patch sampling program (Coastal Frontiers and LGL 1998), in conjunction with historical observations and existing data, led to the conclusion that Boulder Patch habitat (more than 10 percent rock cover) is not represented at the Liberty Island site or along the proposed pipeline corridor. Also, no areas of greater density boulder coverage (10 to 25 percent coverage) were observed within 1,500 ft (457 m) of the island or pipeline route (Coastal Frontiers and LGL 1998). At the closest point, the proposed island appears to lie within $\frac{1}{2}$ mile (0.8 km) of the easternmost boundary of the southerly tip of the Boulder Patch habitat (Figure 1-1).

While the Liberty Development does not directly impinge upon any portion of the Boulder Patch, there is a concern that short-term project construction activities might have some deleterious effects on the kelp community. Specifically, the concern is that suspended sediment introduced into the water column by construction activities will inhibit photosynthetic activity of the kelp and thereby harm the vitality of the community and invertebrates that depend upon it.

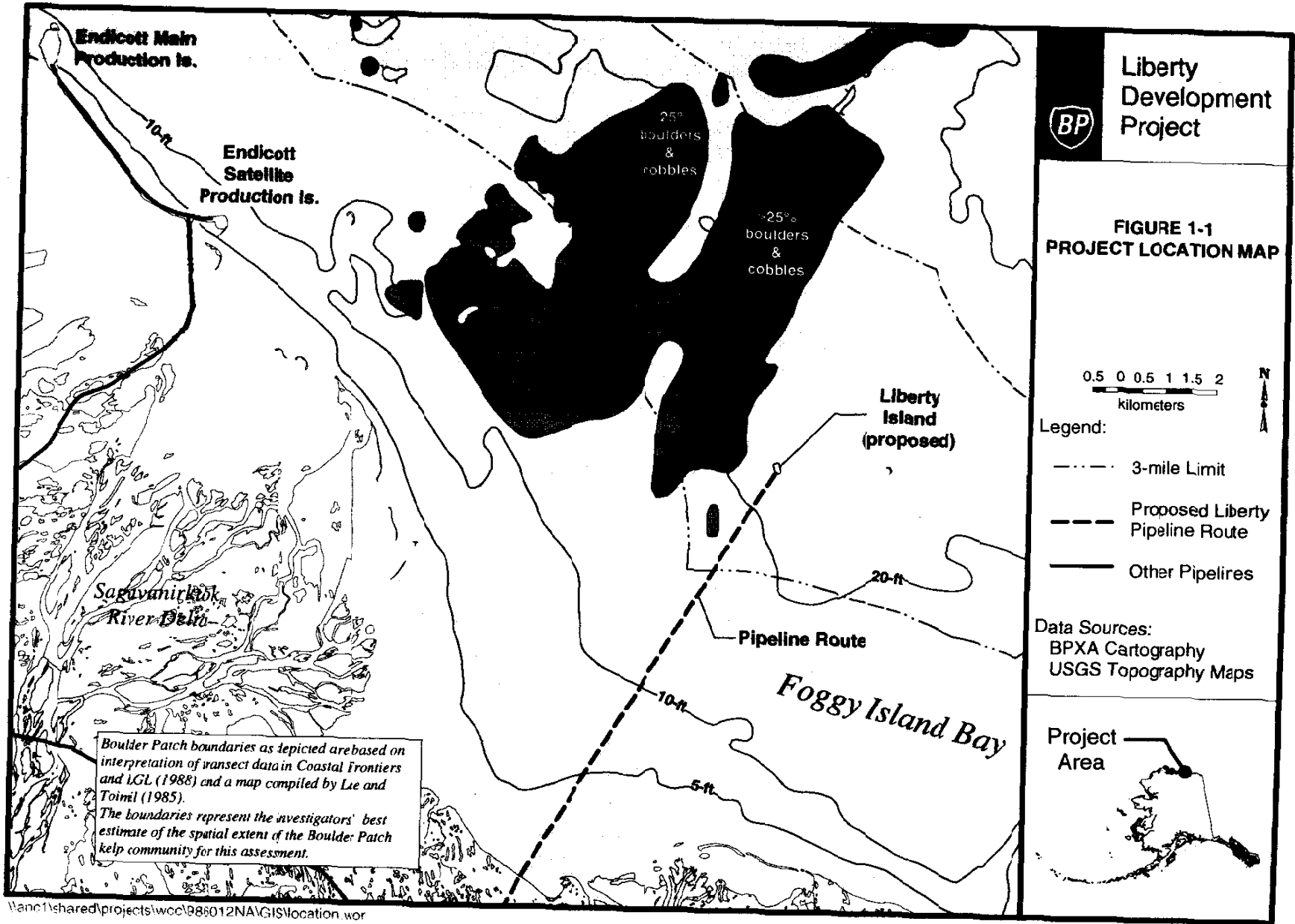

Liberty Development Project



FIGURE 1-1 PROJECT LOCATION MAP

Boulder Patch boundaries as depicted are based on interpretation of transect data in Coastal Frontiers and IGL (1988) and a map compiled by Lee and Toimil (1985). The boundaries represent the investigators' best estimate of the spatial extent of the Boulder Patch kelp community for this assessment.

1.2 PROPOSED CONSTRUCTION PLAN AND SCHEDULE

The Liberty Development Plan includes the following elements:

- Construction of a new gravel island approximately 1.5 miles (2.8 km) west of Tern Island in Foggy Island Bay.
- Placement of drilling, infrastructure, and processing facilities on the island.
- Transportation of sales quality oil from the production island via a buried subsea pipeline to a land-based connection with the Badami Sales Oil Pipeline.

Three construction schedule options are summarized below:

OPTION	WINTER YEAR 1	SUMMER YEAR 1	WINTER YEAR 2
Base Case (proposed)	island construction	no construction	pipeline construction
Single Season (planned option)	island construction concurrent with pipeline construction	no construction	no construction
Summer Pipeline (for purposes of analysis only)	island construction	pipeline construction	no construction

1.2.1 Island Construction

Liberty Island will be a self-contained, drilling and production facility located on a gravel island which will include all support infrastructure and necessary facilities. Island construction will occur during the winter, when Foggy Island Bay is covered with sea ice up to 6 ft (2 m) thick. The island will have approximate surface dimensions of 345 by 680 ft (105 by 207 m) plus a 150 by 160 foot (46 by 49 m) dock (BPXA 1998). To construct the island, gravel will be dropped through the ice to build the island structure upward from the seafloor. Because not all gravel will fall precisely within the design “footprint”, BPXA has identified a construction footprint of about 835 by 1,170 ft (254 by 356 m), allowing an extra 100 ft (30 m) around the perimeter of the design island bottom dimensions. Maximum fill for island construction is expected to be approximately 750,000 cubic yards (577,500 m³) of gravel, thus directly affecting about 22.4 hectares (55 acres). For construction, gravel will be trucked to the site via ice road and dumped through a hole cut through the ice. The hole will be cut successively larger and larger as the fill pile increases to the design dimensions. Ice removed during island construction will be hauled away from the construction site to avoid deflection of the ice around the island and to avoid interference with construction activities.

1.2.2 Pipeline Construction

The pipeline route has two segments, offshore and onshore, of which only the offshore is of concern here. The offshore segment is a nearly straight route from the Liberty Production Island to a landfall located about 6.1 miles (11.3 km) south-southwest of the island (Figure 1-1). Two pipelines are planned for the Liberty Development: a 12-inch (in.) Sales Oil Pipeline and a 6-in. Products Pipeline. These pipelines will be constructed simultaneously in the same trench and will extend from the island to a tie-in with the Badami Pipeline system via the onshore segment. The pipeline system will be constructed within a proposed 1500-ft wide construction right-of-way. For winter construction, an ice road and/or thickened sea ice will be built within the construction right-of-way to support pipeline construction.

Construction will progress from shallower water to deeper water. The pipeline trench will be excavated, pipelines laid in the trench, and the trench backfilled. It is estimated that 724,000 cubic yards (558,000 m³) of material will be excavated, with the intent of replacing as much of this material as possible as backfill within the pipeline trench.

Winter Construction

Backhoes will be deployed as the primary method for excavating the trench. It is estimated that seven backhoes will operate simultaneously along the construction spread. Backhoes will excavate material to the required depth. The backhoe bucket capacities range from 2 to 4 cubic yards (1.5 to 3 m³), and can repeat excavation about once per minute. A front end loader will operate in tandem with each backhoe for loading spoil and transporting it to be backfilled in a nearby trench section or to be stockpiled on the ice in one of two approved zones. As much of the spoils as possible will later be removed from the stockpile and transported to be placed in the trench as backfill.

Hydraulic dredging (agitator pump) will be used as an alternative to a backhoe bucket, particularly when needed to achieve trench bottom smoothness criteria for pipe integrity and in cases where slumping of trench side walls requires hydraulic cleanout. The agitator pump is a relatively small cutter-suction pump/dredge. It will be mounted at the end of the backhoe arm or suspended from a platform on top of the ice to control vertical and horizontal movement. The clean-out tool is powered hydraulically from the surface by a 100 horsepower electric pump. A rubberized discharge hose (up to 10-in. diameter) is connected to the tool and remains under water trailing behind the tool. The amount of material moved will depend on the soil encountered. The discharge hose will trail approximately 200 to 300 ft (61 to 91 m) behind the tool. This discharge nozzle will be tethered so as not to contact the installed pipe and directed back into, or immediately adjacent to the trench. It is estimated that the dredged material will be 60 - 70 percent solids and 30 - 40 percent liquid. Excavation rates using the dredge are estimated at 150 cubic yards (116 m³) per hour.

Trench backfill will include both native spoils as well as select backfill. The latter will include gravel and gravel-filled polyester bags, as needed to ensure pipeline stability. Loose gravel will be used as trench fill material where needed for pipeline support. Gravel-filled geotextile bags will be placed axially across the pipeline in the trench to help hold the pipeline in place. The bags will then be buried with backfill material. Using this method, bags will be buried well below the seafloor, and will not be exposed to ice or erosion forces.

Summer Construction

A summer construction option is not proposed at this time; however, a discussion is included for the purposes of analysis. Summer excavation of the pipeline trench could be completed using the hydraulic dredge described above, or with a "plow" system. All excavation equipment will be barge-mounted. The disposition of excess dredged materials is undetermined at this time.

1.3 CONSTRUCTION ACTIVITIES AND ENVIRONMENTAL CONCERNS

Island construction and installation of the pipeline from the mainland to Liberty Island are expected to increase suspended sediment load in the water column. Remaining stockpiled spoils will be released to the water column as the ice melts at breakup and thereby provide an additional release of suspended sediments to the water column. Increased sediment input can affect kelp or other benthic organisms through:

- Deposition of sediments on the community
- Attenuation of natural light available for photosynthesis.

Deposition of sediments is not expected to have adverse effects. Increased sedimentation rates as estimated to result from project activities are within the range encountered under natural conditions by the kelp (see Section 2.1). Natural sedimentation frequently occurs at rates above those expected from construction activities. The resulting sediment "blankets" are rapidly cleared from the kelp blades by bottom currents or resuspension events characteristic of the area. The depositional events occur at a frequency and duration below that which significantly impair the kelp.

Therefore, the attenuation of natural light due to increased total suspended solids (TSS) concentrations and/or turbidity in the water column during both open-water (July-Sept) and ice-covered periods (Oct-June) is of greatest environmental concern. Kelp beds resident in Boulder Patch areas might be adversely affected by a reduction in available light. Construction induced sources of increased TSS are described below.

1.3.1 Island Construction

Island construction will occur during the ice-covered period, so most of the increased TSS attributable to this activity will occur during winter. However, increased turbidity attributable to island construction might also be expected during the following open-water season as finer sediments are winnowed from the island or during grooming of the island slopes after breakup. The winnowing will be controlled by encasing the island in a geotextile fabric. Any increased turbidity due to winnowing will likely be overshadowed by the turbidity plumes from the Sagavanirktok and other rivers that empty into Foggy Island Bay during breakup.

1.3.2 Pipeline Construction

Pipeline construction and associated suspended sediment increases are expected to occur during the ice-covered period; either concurrent with island construction or following a year later.

Should pipeline construction efforts be conducted during the summer, increased suspended sediment loads from these efforts could also be evident during the open-water period.

1.3.3 Ocean Disposal of Spoil Piles

Accumulation of excess backfill may result due to several factors, including displacement by the pipeline, the use of select backfill (e.g. gravel), and bulking due to the natural swell of excavated materials placed back into the trench. Another case may result from uncontrolled circumstances (e.g., bad weather) that may force construction crews to abandon the site before all operations have been completed, leaving some excavated material on the ice surface. Therefore, construction activity may result in ocean disposal of up to 110,000 cubic yards (85,000 m³) of dredged material spoils. At breakup, this material will be released into the water column, thereby increasing suspended sediment load as the spoil piles melt.

SECTION TWO Introduction of Suspended Sediments By Construction Activity

2.1 AMBIENT CONDITIONS

2.1.1 Summer Conditions (Open-Water)

During the summer open-water season, the timing and rate of discharges from the Sagavanirktok, Kadleroshilik, and Shaviovik rivers determine the amount of freshwater and associated suspended sediments available for distribution in the marine environment of Foggy Island Bay. The first open water typically occurs in late June to early July and, as warming continues into summer, the sea ice melts, resulting in about 75 days of open water (USACE 1987-1993).

Discontinuous sea ice is prevalent throughout the central Beaufort Sea during early summer (June to mid-July), limiting wind stress applied to the water column. The average current speed during June and July is only about 0.04 knots (kt) [5 centimeter/second (cm/s)] (USACE 1987-1993). As the open-water season progresses and the area is freed of large concentrations of sea ice, the water surface is more exposed to the prevailing winds. Then the average current speed (August-September) is about 0.3 kts (14 cm/s) with a maximum observed speed of 1.3 kts (68 cm/s) (USACE 1987-1993). These observations, while collected near the Endicott development as part of the Endicott Monitoring Program, are generally applicable to Foggy Island Bay.

In mid-June through early July, the shallow nearshore waters generally carry more suspended sediment as a result of increased sediment load discharged from the rivers (Sagavanirktok, Kadleroshilik and Shaviovik), and thus, very high turbidity is observed adjacent to the river mouths. Storms, wind and wave action, and coastal erosion increase turbidity in shallow waters periodically during the open-water season. Turbid conditions persist in areas where the sea floor *consists primarily of silts and clays as compared to areas having mostly a sandy bottom.*

Suspended sediment concentrations are governed primarily by wind-induced waves and freshwater input from the Sagavanirktok River and other major rivers (USACE 1987). Britch et al. (1983) found peak suspended sediment concentrations were associated with intervals of highest significant wave heights. The 1983 study reported a maximum TSS value of 324 mg/L at a nearshore station associated with the Endicott Development, and an average of 45 mg/L. During and immediately after storms, naturally occurring suspended sediment concentrations exceeded 50 mg/L near Tern Island (Britch et al. 1983). During the 1998 open-water season (URS Greiner Woodward Clyde 1999), the average TSS value in the vicinity of the proposed Liberty Island was 30 mg/L, similar to the 1983 study. In-situ turbidity measurements collected during the 1998 open-water season ranged between 1 and 173 nephelometric turbidity units (NTU).

2.1.2 Winter Conditions (Ice-Covered)

Winter ice cover of the Beaufort Sea begins to form in late September. Freezeup of the waters is usually completed by the end of October, with ice growing to a maximum thickness of 7.5 ft (2.3 m) by April (MMS 1996). Ice cover persists on average for 290 days until spring warming results in river breakup, and subsequent sea ice melting near the river and stream deltas.

Under-ice observations in the Beaufort Sea indicate only very slow currents that are aligned with bathymetry, in response to a generally eastward or westward coastal circulation. The average current speed observed during ice-covered conditions at the site is less than 0.04 kt (2 cm/s)

SECTION TWO Introduction of Suspended Sediments By Construction Activity

(Montgomery Watson 1997; Berry and Colonell 1985). The typical water column structure observed under sea ice in the Beaufort Sea is uniform, with no stratification of temperature, salinity, or density.

Dunton (1990) documented that turbid ice occurs at a frequency of approximately 60% on both temporal as well as spatial scales. The turbid ice is likely formed when sediments and other solid matter in the water column is incorporated into the ice as it forms. However, there are no empirical data describing the relationship between TSS in the water column and corresponding opaqueness of the ice canopy.

The presence of ice cover precludes wave action, which is the major natural cause of sediment re-suspension and turbidity (MMS 1996). Under-ice TSS values along and in the vicinity of the proposed Liberty pipeline route ranged from 2.5 to 76.5 mg/L, with the highest values collected closest to the seabed and likely due to disturbance of the bottom sediments (Montgomery Watson 1997, 1998). Field-measured turbidity for February and March under-ice conditions ranged from 1 to 35.6 NTU, and laboratory-measured turbidity ranged from 0 to 24 NTU (Montgomery Watson 1997, 1998). Normally, under-ice water column TSS concentrations are less than 10 mg/L, but storms or other disturbances can stir up bottom sediments as evidenced by observation of turbid layers frozen into the sea ice.

2.2 INTRODUCTION OF SUSPENDED SEDIMENTS BY CONSTRUCTION ACTIVITY

Sediments are introduced into the water column by construction activity that involves any of the following processes:

1. Free-fall of sediments through the water column causes finer sediments to be washed out:
 - a) During island construction, when gravel is dropped from sea ice surface to seabed;
 - b) When spoil piles fall through the melting sea ice cover during spring breakup; and
 - c) During backfilling of the pipeline trench, when excavated materials are dropped through sea ice surface to seabed.
2. Re-suspension of sediments, by washout of finer particles or by disturbance of seabed:
 - a) During repeated lifting of seabed materials through water column, as with backhoe excavation of the pipeline trench; and
 - b) During operation of dredges, jets, or seabed "plows" for pipeline placement in the seabed
 - c) During winnowing of fines from island slopes by prevailing currents.

The analytical objective is to determine the water column concentration of *excess* suspended sediment (XSS) that occurs as a result of construction activity. "Excess" is meant to represent the concentration of suspended sediment *above ambient*, or natural, level at the location in question for the season and weather conditions. By determining XSS as a function of distance from the point of introduction (i.e. island, pipeline trench, etc.), it is then possible to estimate both areal and temporal exposures of any portion of the Boulder Patch kelp community to the additional sediment introduced by construction activities

SECTION TWO Introduction of Suspended Sediments By Construction Activity

For all cases the first step is to determine the *initial concentration* of sediments at the point of introduction, hereafter referred to as the "source." This requires identification of the hydrodynamic mechanisms by which sediments are introduced into the water column, culminating in an *assumption* for the percentage of the finer particles that are actually introduced as a result of the construction activity. While the best knowledge of the hydrodynamics of each situation has been incorporated in the analysis, it is important to emphasize that the percentages assumed for introduction of sediments are estimates only, because there are very few experimental data available to verify the computations.

A detailed discussion of the analytical scheme used to calculate XSS that occurs as a result of construction activities is provided in Appendix A. Analytical results were mapped to determine *the areal extent of potential effects on the Boulder Patch due to "plumes" or "clouds" of XSS transported by prevailing currents.*

2.3 INCREASED SUSPENDED SEDIMENT DUE TO CONSTRUCTION ACTIVITY

Computational results of the analysis of suspended sediment transport toward and through the Boulder Patch are presented in Table 2-1 for each of four construction activities: island construction, pipeline trench excavation (summer and winter), and ocean disposal of soil stockpiles. The following three subsections provide remarks and assumptions specific to the analysis of each construction activity, as well as graphical depictions of the results on maps of the Liberty Boulder Patch area.

2.3.1 Liberty Island Construction

Winter construction of the gravel island will likely increase suspended sediment concentrations in marine waters during placement of fill material. Excess suspended sediment concentrations and dimensions of the resulting sediment plume generated by the construction activities will depend on a number of factors including:

- Timing of the construction activities
- Physical characteristics of the fill material
- Water depth and ice cover at the construction site
- Current speed
- Circulation patterns in the vicinity of the site

As part of the Lisburne Project Environmental Assessment (Dames and Moore 1988), it was determined that most of the fill material used for construction in the Prudhoe Bay area has a maximum of 10 percent fines (i.e., fine particles). The Dames and Moore (1988) assessment assumed for determination of some offshore impact analyses that 10 percent of the fines in the fill material below mean water level would be washed out during construction of a gravel island or causeway. However, others contend that the construction standard for gravel in the Prudhoe Bay area is only 5 percent fines, and that the material used to construct Tern Island in Foggy Island Bay had an average of only 2 percent fines (WCC 1982). NORTEC (1981) estimated that up to 12 percent of fines contained in fill material placed below water during open water

SECTION TWO Introduction of Suspended Sediments By Construction Activity

Table 2-1. Summary: Excess Suspended Sediments Due to Construction Activities

CONSTRUCTION ACTIVITY	BOULDER PATCH AREA POTENTIALLY AFFECTED				AREAL AND TEMPORAL EXTENTS OF EXPOSURE		
	XSS (mg/L)	>25% Boulder (km**2)	10-25% Boulder (km**2)	Total Area (km**2)	Plume / Cloud [1] Width (m)	Length (m)	Maximum Exposure [2]
ISLAND							
<u>Winter Construction</u> Initial XSS = 250 mg/L Current = 0.02 m/s	>20 10-20 Totals	0.09 0.19 0.28	0.00 0.00 0.00	0.09 0.19 0.28	400	continuous plume	45 days
PIPELINE TRENCH							
<u>Winter Construction</u> Initial XSS = 1,000 mg/L Current = 0.02 m/s	>200 100-200 50-100 20-50 10-20 Totals	0.00 0.02 0.11 0.08 6.68 6.90	0.00 0.12 0.04 0.00 8.32 8.48	0.00 0.14 0.15 0.08 15.00 15.38	60-75	1,730	24-48 hr [3]
<u>Summer Construction</u> Initial XSS = 1,000 mg/L Current = 0.10 m/s	>300 200-300 100-200 50-100 20-50 Totals	0.00 0.20 3.21 2.07 0.72 6.20	0.00 0.16 1.96 2.64 1.84 6.60	0.00 0.36 5.17 4.71 2.56 12.80	120 -150	8,600	24-48 hr [3]
OCEAN DUMPING							
<u>Dispersal at breakup</u> Stockpile Zone 1 Initial XSS = 1,168 mg/L Current = 0.05 m/s	>20 10-20 Totals	0.00 0.50 0.50	0.00 3.25 3.25	0.00 3.76 3.76	2000	4,300	24-48 hr [3]
<u>Dispersal at breakup</u> Stockpile Zone 2B Initial XSS = 14 mg/L Current = 0.05 m/s	>20	0	0	0			
[1] Only island construction produces a "plume" of excess suspended sediments; all other cases result in "clouds" of XSS, having limited length, due to short duration of discharges. [2] "Maximum" exposure only if coastal circulation is westward for entire construction period, on average, expect circulation to be westward 60-70% of time, so average expected exposure would be 60-70% of times indicated. [3] Duration of exposure of any specified location is limited to time of "cloud" passage over that location; i.e., for XSS attributable to pipeline construction and stockpile dispersal, exposure of any specified area is < 48 hr.							

SECTION TWO Introduction of Suspended Sediments By Construction Activity

conditions may be entrained during construction. For Liberty Island it is estimated that 577,500 m³ (750,000 yd³) of gravel will be placed at a maximum rate of 15,500 m³ (20,000 yd³) per day over a period of about 45 days. The geotechnical investigation of the Kadleroshilik River mine site determined that the borrow material expected to be used for island construction is composed of about 10 percent fine materials (Duane Miller & Associates 1998). If it is assumed that 12 percent of the fines will be released to the water column during placement, then 186 m³ (240 yd³) of material will be released to the water column each day. With a typical density of 2.6 for the material, this corresponds to 484,000 kg/day or 5.6 kg/s.

For an average island diameter of 183 meters, water depth of 6.1 m, and winter current speed of 0.02 m/s, this yields an initial excess suspended sediment concentration of 250 mg/L.

As a worst-case assumption, computations of excess suspended sediment transport toward the Boulder Patch were performed with the initial concentration of 250 mg/L. As indicated in Table 2-1, and depicted in Figure 2-1, approximately 0.3 km² with >25% boulder cover could potentially be affected by a plume containing greater than 10 mg/L suspended sediment. Island construction results in a "plume" of suspended sediment because input of sediment will be continuous for the entire island construction period. For the expected construction period, the *maximum* duration of exposure of the 0.3 km² of Boulder Patch is 45 days; however, historical data on the circulation of Beaufort Sea coastal waters shows that, on average, the currents are westerly only 60-70% of the time. Accordingly, the *more likely* exposure would be about 30 days of the construction period.

2.3.2 Pipeline Construction – Winter or Summer

Excavation, grooming, and backfilling of the pipeline trench from the mainland to Liberty Island are expected to increase suspended sediment load in the water column. Of particular concern are the smallest sediment particles, called "fines," that might be washed out of the seabed soil during this construction activity, and then remain in the water column as suspended sediment.

Winter excavation of the pipeline trench will be accomplished with a backhoe, equipped with a 2 to 4 yd bucket. As the backhoe bucket is lifted through the water column, the flow of water over the top of the bucket will wash a small portion of the fines from the exposed surface of the soil load. The amount of fines washed out of the backhoe bucket will be partially dependent upon the depth of the water column through which the backhoe is raised. It is expected that some of the fines will be washed from the soil during backfilling. However, because there are no data with which to confirm an analytical approach to estimate the quality of sediment washed out of the backhoe, it becomes necessary to rely on empirical observations.

To evaluate the effectiveness of backhoe operations from the sea ice surface, a test trench was excavated during the winter of 1996 on the proposed pipeline route for the Northstar Development. The excavation method used was comparable to that anticipated for Liberty. Water samples were collected at several locations to observe increases in suspended sediment that could be attributed to the excavation activity. A water sample collected at the seafloor during trenching operations had a TSS concentration of 885 mg/L. Samples collected within 150 m of the trench showed TSS concentrations ranging from 20 to 121 mg/L, while beyond 150 m, TSS concentrations ranged from 19 to 35 mg/L (Montgomery Watson 1996).

Endicott Main
Production Is.

Endicott
Satellite
Production Is.

<25%
boulders
&
cobbles

>25%
boulders
&
cobbles

10 mg/L
20 mg/L
25 mg/L
50 mg/L

Liberty
Island
(proposed)

20-ft

Pipeline Route

10-ft
5-ft
Foggy Island Bay

Sagavanirktok
River Delta

Boulder Patch boundaries as depicted are based on interpretation of transect data in Coastal Frontiers and LGL (1988) and a map compiled by Lee and Toimil (1985). The boundaries represent the investigators' best estimate of the spatial extent of the Boulder Patch help community for this assessment.



Liberty Development Project

**FIGURE 2-1
MAXIMUM EXPOSURE
TO SUSPENDED SOLIDS
RESULTING FROM
LIBERTY ISLAND
CONSTRUCTION
(Winter Conditions)**

Concentrations in mg/L

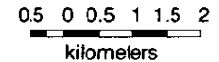

Legend:

- - - - 3-mile Limit
- - - - Proposed Liberty Pipeline Route
- _____ Other Pipelines

Data Sources:

BPXA Cartography
USGS Topography Maps

Project
Area

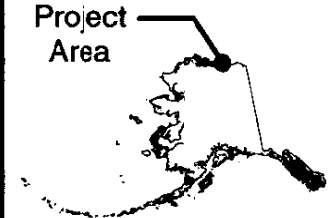

SECTION TWO Introduction of Suspended Sediments By Construction Activity

For purposes of estimating effects of operations, it was assumed that the initial XSS concentration would be a uniform 1,000 mg/L from seabed to underside of sea ice, over the entire length of the pipeline trench. This corresponds approximately to assuming sediment entrainments of 2% in 1-m, and up to 10% in 5-m water column (beneath ice), respectively.

If the pipeline trench is excavated during summer, it is anticipated that a hydraulic suction dredge will be utilized. Lacking any data on the amount of seabed sediment that might be re-suspended by this operation, as well as any rational approach by which to estimate the re-suspension, computations for the summer construction option utilized the same (conservative) estimate of initial XSS concentration as for the winter case; i.e., a uniform 1,000 mg/L from seabed to water surface, over the entire pipeline trench alignment. The assumption of an initial XSS concentration of 1,000 mg/L for both winter and summer trench excavation activity is considered to be very conservative, especially in the deeper sections of the pipeline trench (i.e., where depth > 3 m).

Computational results show that during winter, even with initial XSS concentration of 1000 mg/L at the pipeline, all but 10-20 mg/L has fallen to the seabed prior to reaching significant portions of the Boulder Patch (Figure 2-2). During summer, with same initial TSS concentration, 100-200 mg/L of excess suspended sediment remain in water column over the portion of Boulder Patch nearest Liberty Island, while lower concentrations (20-100 mg/L) remain over sections more distant from the island (Figure 2-3). The greater potential impact of summer excavation is due, of course, to the greater current speed being able to transport the excess suspended sediment much further before it falls to the seabed. However, this potentially greater impact will produce less change over ambient conditions, since there is greater ambient sediment load in the water column due to influx from the nearby Saganavirktok River and from wave-induced re-suspension of seabed sediments.

It should be noted that, during both summer and winter, the increased sediment load attributable to excavation of the pipeline trench is a *transient* phenomenon. This is because the origin of the suspended sediment load at the pipeline trench is essentially a short-term *moving point source*, coinciding with movement of backhoes along the pipeline alignment, generating sediment "clouds" that are carried northeastward by the (assumed) prevailing currents. As such, any given point on the seabed is affected by a sediment "cloud" for only a short time—estimated to be no more than two days during winter, and less than a single day during summer, for the current speeds noted above. Accordingly, the areas depicted in Figures 2-2 and 2-3 as "maximum exposure" should be regarded only as *envelopes* of sediment cloud trajectories over the Boulder Patch. As previously noted, the conditions depicted in Figures 2-2 and 2-3 are relevant only when the general circulation is westward, which occurs on average 60-70% of the time.

Endicott Main
Production Is.

Endicott
Satellite
Production Is.

>25
boulders
&
cobble

>25
boulders
&
cobble

Liberty
Island
(proposed)

Sagavanirktok
River Delta

10 - 20 mg/L

Pipeline Route

Foggy Island Bay

Boulder Patch boundaries as depicted are based on interpretation of transect data in Coastal Frontiers and IGL (1988) and a map compiled by Lee and Toimil (1985). The boundaries represent the investigator's best estimate of the spatial extent of the Boulder Patch kelp community for this assessment.

Liberty Development Project



**FIGURE 2-2
MAXIMUM EXPOSURE
TO SUSPENDED SOLIDS
RESULTING FROM
PIPELINE
CONSTRUCTION
(Winter Conditions)**

Concentrations in mg/L

0.5 0 0.5 1 1.5 2

kilometers



Legend:

- - - - 3-mile Limit
- - - - Proposed Liberty Pipeline Route
- Other Pipelines

Data Sources:
BPXA Cartography
USGS Topography Maps

Project
Area



Endicott Main
Production Is.

Endicott
Satellite
Production Is.

~25%
boulders
&
cobble

~25%
boulders
&
cobble

Liberty
Island
(proposed)

Sagavanirktok
River Delta

Pipeline Route

Foggy Island Bay



Liberty Development Project

**FIGURE 2-3
MAXIMUM EXPOSURE
TO SUSPENDED SOLIDS
RESULTING FROM
PIPELINE
CONSTRUCTION
(Summer Conditions)**

Concentrations in mg/L

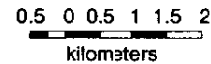

Legend:

- - - - 3-mile Limit
- - - - Proposed Liberty Pipeline Route
- Other Pipelines

Data Sources:
BPXA Cartography
USGS Topography Maps

Project
Area



Boulder Patch boundaries as depicted are based on interpretation of transect data in Coastal Frontiers and LGL (1988) and a map compiled by Lee and Toimil (1985). The boundaries represent the investigators' best estimate of the spatial extent of the Boulder Patch kelp community for this assessment.

SECTION TWO Introduction of Suspended Sediments By Construction Activity

2.3.3 Ocean Disposal of Stockpiled Material

As the pipeline trench is excavated, seabed materials will be stockpiled on the sea ice surface in two locations—at a nearshore area (Zone 1) and along the pipeline alignment (Zone 2). The latter stockpile has two parts, called Zones 2A and 2B, but is considered to be a single location. Upon completion of the pipeline burial, it is expected that a maximum of 110,000 yd³ (84,600 m³) of seabed materials could remain on the sea ice surface, with about 90% in Zone 1 and 10% in Zone 2B. Zone 2A will be scraped clean upon completion of pipeline burial.

BPXA has applied for an ocean dumping permit to allow the remaining stockpiled materials to fall to the seabed during the spring breakup of sea ice. This permit would be issued by the U.S. Army Corps of Engineers under Section 103 of the Marine Protection, Research and Sanctuaries Act: Dredged Material Disposal Site Evaluation.

As with the other sources of excess suspended sediment, the first step in the analysis of dispersal of the stockpiled materials is to determine the initial concentration, which depends upon how the materials are actually “discharged,” or dropped, into the water column. Three factors that enable this determination must be assumed:

- *Duration* of material discharge into the water column through the broken sea ice;
- *Fraction* of material that is entrained in the water column as it falls to the seabed, and becomes available as suspended sediment for transport away from the site; and
- *Current speed* that determines actual concentration of sediment in the water column.

Lacking any data, or even anecdotal observations, it was assumed that the duration of discharge through the broken sea ice will be 24 hr and that 10% of the sediment will be entrained during its fall to the seabed. A current speed of 0.05 m/s was assumed for the transport computations, based on knowledge that floating ice limits the area of water surface that can respond to wind stress, so current speeds are somewhat lower during the spring breakup period than would be typical of open-water (i.e. ice-free) conditions. Utilization of these assumptions, along with characteristics of the stockpiled materials (Table 2-2), in direct application of Equations 1-6 in Appendix A yields initial XSS concentrations of 1,168 mg/L and 14 mg/L, respectively, for Zones 1 and 2B.

Table 2-2 Ocean disposal of stockpiled materials – dimensions and concentrations

Zone	Dimensions (ft)	Water Depth		Volume m ³	Initial excess suspended sediment concentrations (mg/L)
		ft	m		
1	5,000 x 2,000	5 - 7	1.5 - 2.2	76,455	1,168
2A	250 x 17,900	0 - 5	0 - 1.5	nil	--
2B	250 x 13,700	16 - 22	4.9 - 6.7	7,645	14

Results of the sediment transport computations are depicted graphically in Figure 2-4. It is evident that excess suspended sediment only from Zone 1 can potentially affect any portion of the Boulder Patch and, even then, only in concentrations less than 20 mg/L. As with previous

SECTION TWO Introduction of Suspended Sediments By Construction Activity

figures, only the effect of currents associated with westward coastal circulation is shown; on average this represents 60-70% of the total time.

The combination of 24 hr and 10% assumed, respectively, for *duration* of discharge and *fraction* of sediments entrained is considered to be conservative. While a shorter time for actual discharge would (theoretically) cause the initial concentration to be higher, it is more likely that the stockpiled materials will remain mostly frozen until they fall through the ice and, even then, they will not thaw during their short fall to the seabed. Of course, a longer duration of discharge would result in a lower initial concentration, but it is unlikely that any greater fraction of the material would be thawed and available for entrainment. Thus, while the uncertainty regarding the discharge duration remains large, it appears that the assumed fraction of sediments entrained is sufficiently conservative to compensate for that uncertainty.

2.3.4 Re-suspension of Stockpiled Materials

A remaining concern associated with the ocean disposal of the stockpiled materials is whether they might become re-suspended by wave action and then transported toward the Boulder Patch. To *re-suspend* materials from the seabed, surface wave action must be sufficiently vigorous to cause agitation of the bottom sediments by the orbital motions induced in the water column by the waves. Wave length and height are the measures that indicate whether the waves are "sufficiently vigorous." As a general rule, if the wave length is greater than four times the local water depth, the wave-induced currents will be sufficient to resuspend loose (fine) bottom sediments, even with relatively small wave heights. Thus the *minimum* length of wave capable of re-suspending bottom sediments will be four times the local water depth. The first step in the analysis is to determine the wind conditions necessary to generate waves of sufficient length to resuspend bottom sediments.

In Foggy Island Bay, as elsewhere along the entire Beaufort Sea coast, water column movements are due almost entirely to the frictional stress of wind on the water surface. For resuspended sediments to be transported from the deposit sites to the Boulder Patch, water column movements must be directed northward from the deposit sites toward the Boulder Patch. So *concern is limited to southerly winds* that generate waves capable of resuspending bottom sediments at the two deposit sites.

The final step in the analysis is to determine a *realistic probability of occurrence* of events necessary to (1) resuspend bottom sediments at the deposit sites, and then (2) transport the resuspended sediments in quantities large enough to affect the Boulder Patch.

2.3.4.1 Computations

Reference to a map of the Liberty Development area shows that fetch distances for winds from southerly directions, defined as the sector between the directions SSE and SSW, are all short (< 10 miles) because of the proximity of the coastline (Figure 1-1 and Table 2-3).

Liberty Development Project



**FIGURE 2-4
MAXIMUM EXPOSURE
TO SUSPENDED SOLIDS
RESULTING FROM
OCEAN DISPOSAL
(Breakup Conditions)**

Concentration in mg/L

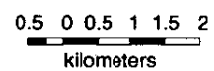

Legend:

- - - - 3-mile Limit
- - - - Proposed Liberty Pipeline Route
- Other Pipelines

Data Sources:
BPXA Cartography
USGS Topography Maps

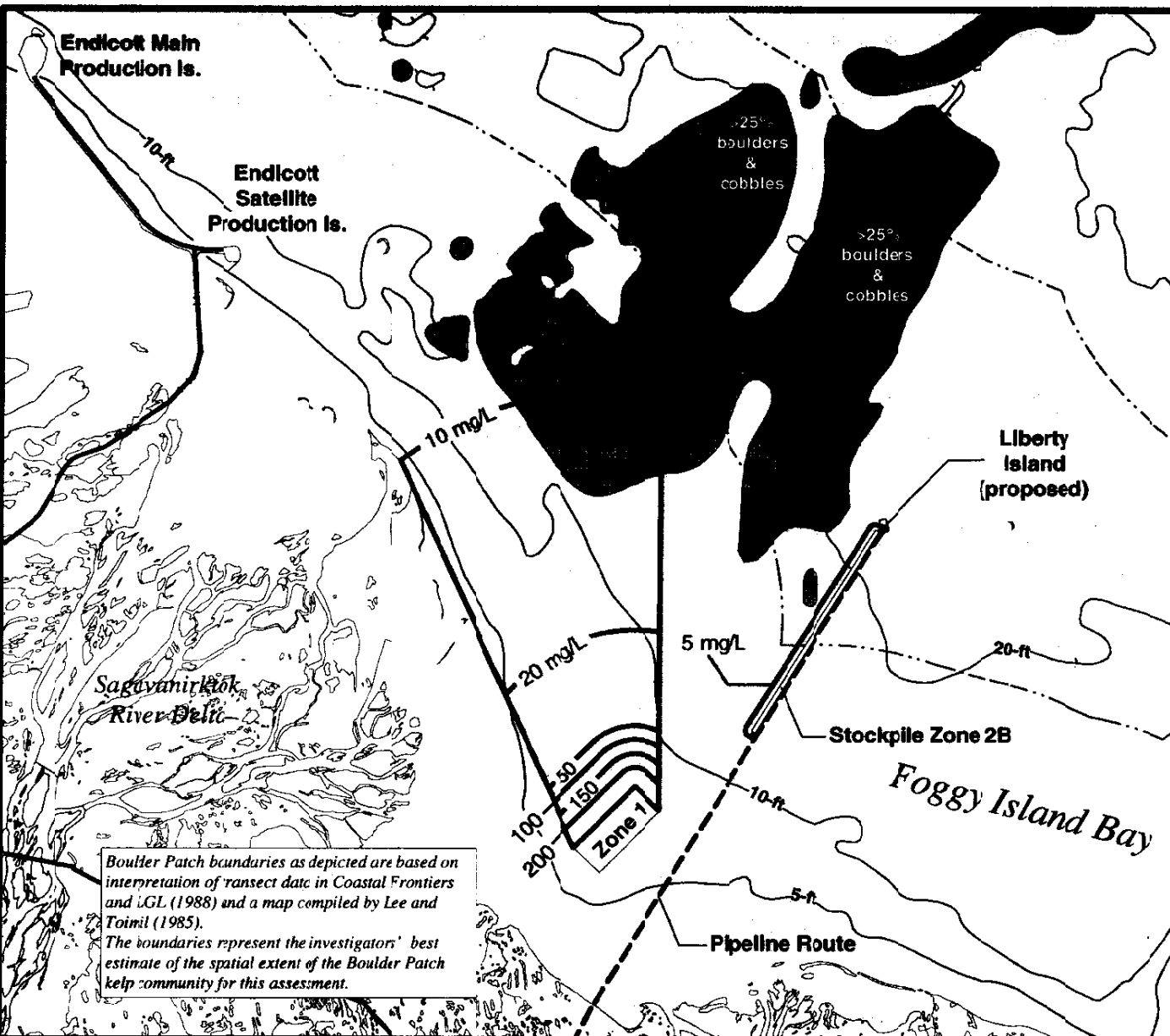
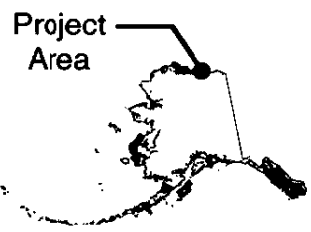

Boulder Patch boundaries as depicted are based on interpretation of transect data in Coastal Frontiers and LGL (1988) and a map compiled by Lee and Toimil (1985). The boundaries represent the investigators' best estimate of the spatial extent of the Boulder Patch help community for this assessment.

SECTION TWO Introduction of Suspended Sediments By Construction Activity

Table 2-3. Water depths and applicable fetch distances for disposal sites

Disposal Site	Water Depth (ft)	Fetch (mi.) for wind from indicated direction		
		SSW	South	SSE
Zone 1	6-8	1-2	1.5-2	2
Zone 2 - south end	10	3	2.5	3
Zone 2 - north end	20	6	5	6

For resuspension of bottom sediments in Zone 1, where water depths range from 6-8 ft, the waves must have lengths greater than about 24 to 32 ft, depending on location within the disposal site, for which fetch distances are 1-2 miles. For resuspension to occur in Zone 2, the waves must be at least 40 ft long at the southern end (10 ft deep), but more than 80 ft long at the northern end (20 ft deep), where fetch distances are 3 and 6 miles, respectively.

Using wave prediction formulas as presented in standard references on the subject (e.g., Coastal Engineering Research Center 1984), characteristics were computed of waves generated under various combinations of wind speed (3-50 mph) and fetch (1-10 miles). In Table 2-4 are listed some of the computational results, which have been selected for their applicability to the question of resuspension of bottom materials for fetch distances and water depths that are characteristic of the two disposal sites.

Table 2-4. Wave length as a function of wind speed and fetch

Wind (mph)	Fetch (miles)			
	1	2	3	6
	Zone 1		Zone 2	
	Wave Length (ft)			
3	3	5	7	11
5	5	7	10	15
8	6	10	13	21
10	7	12	15	24
15	10	15	20	32
20	12	19	24	38
30	15	24	32	51
50	22	34	45	71

These results indicate that for fetch distances of 1-2 miles, which are applicable to Zone 1 where water depths range from 6 to 8 ft, wind speeds of *at least* 50 mph would be required to re-suspend sediments at this disposal site. For Zone 2, where depths vary from 10 to 20 ft, a similar conclusion is reached even though the fetch distances are greater at 3-6 miles; that is, winds of *at least* 50 mph would be required to re-suspend sediments at this disposal site as well.

Statistical analyses of meteorological data from Deadhorse airport, which is sufficiently similar to the Liberty Development area for this purpose, show that the wind blows from southerly directions (SSE to SSW) only 5% of the time and, further, the maximum wind speed of record from these directions is only 8 mph. Therefore, it is reasonable to conclude that the probability of occurrence of 50-mph southerly winds is virtually zero.

SECTION TWO Introduction of Suspended Sediments By Construction Activity

2.3.4.2 Conclusion

Given the high wind speeds necessary to generate waves having sufficient energy to resuspend bottom sediments at the short fetches characteristic of the two disposal sites, and the statistical improbability of such winds occurring, there is no reason to believe that the grounded dredge spoils could be resuspended and then transported toward the Boulder Patch.

3.1 ENVIRONMENTAL CONDITIONS AND KELP VITALITY

The Boulder Patch in Stefansson Sound is considered to have the highest unit biomass and most diverse fauna found in the Alaskan Beaufort Sea (Dunton et al. 1982). The dominant member of the community is a kelp, *Laminaria solidungula*, which is exceptionally well adapted for low-light conditions characteristic of the arctic (Dunton and Jodwalis 1988). This particular kelp, along with two others form a canopy under which lies a patchy algal community. The canopy and the boulders provide a diversity of microhabitats and substrate types which support a broad array of invertebrate species.

Growth of *L. solidungula* was found to be both energy- and nitrogen-limited because the two resources are not available in sufficient quantities simultaneously (Dunton et al. 1982). However, this kelp has developed a life history strategy that enables it to deal successfully with these constraints. During the summer open-water period when light is available, the plants must store all the carbon necessary for their annual growth, reproduction and metabolism. However, little linear growth occurs during this period due to insufficient concentrations of inorganic nitrogen needed for synthesis of new tissue. The products of photosynthesis, carbohydrates in the form of laminarin or manitol, are stored and used during the winter when inorganic nitrogen concentrations have increased to levels enabling growth of a new blade (Dunton and Schell 1986). Because of this pattern, *L. solidungula* completes nearly 90 percent of its annual linear growth in darkness under a turbid ice cover that completely excludes light from late October to late June (Dunton et al. 1982). In some years, when the ice canopy is clear, light reaches the plants during spring, and annual growth increases significantly (Dunton 1984). The kelp do not require this winter growth under clear ice to survive, so it can be viewed as a "bonus" in the kelp's overall life history strategy. Kelp production provides 50 to 56 percent of the carbon available to Boulder Patch consumers and releases approximately 60 percent of the particulate organic matter found in the kelp-bed environment (Dunton 1984)

3.1.1 Calculation of Kelp Production Rates

Previous studies have shown that significant kelp production is limited to areas having at least 10 percent rock cover. A greater coverage of boulders supports more kelp plants as evidenced by kelp biomass measured as mean thallus weight per square meter. For example, kelp biomass in areas having more than 25 percent rock cover is characterized by a mean thallus weight of 262.1 g/m². This biomass is substantially greater than areas with 10 to 25 percent rock cover which have a mean thallus weight of 66.7 g/m² (Dunton et al. 1982). Wet weight biomass can be converted to production rates:

$$\text{Production (g C/m}^2\text{/yr)} = (\text{thallus wet wt.})(\% \text{ dry wt. of wet wt.})(\% \text{C of dry weight})(\text{Production:Biomass ratio})$$

For Boulder Patch kelp, dry weight is 16 percent of wet weight, and carbon content is 33 percent of dry weight (Dunton 1990). Production to biomass ratios (P:B) have been determined as 0.91 without winter photosynthesis (turbid ice) and 1.44 with winter photosynthesis under clear ice (Dunton 1984). Thus for Boulder Patch areas having more than 25 percent rock cover:

SECTION THREE

Effects of Altered Water Quality On Boulder Patch Kelp

$$\text{Production}_{\text{clear ice}} = (262.1 \text{ g/m}^2) (0.16) (0.33)(1.44) = 19.9 \text{ gC/m}^2/\text{yr}$$

$$\text{Production}_{\text{turbid ice}} = (262.1 \text{ g/m}^2) (0.16) (0.33)(0.91) = 12.6 \text{ gC/m}^2/\text{yr}$$

Similarly, for habitats with 10 to 25 percent rock cover estimated production rates are:

$$\text{Production}_{\text{clear ice}} = (66.7 \text{ g/m}^2) (0.16) (0.33)(1.44) = 5.1 \text{ gC/m}^2/\text{yr}$$

$$\text{Production}_{\text{turbid ice}} = (66.7 \text{ g/m}^2) (0.16) (0.33)(0.91) = 3.2 \text{ gC/m}^2/\text{yr}$$

To estimate the net total annual kelp production for the Boulder patch, without any potential effects from the Liberty Development, the area (km²) of each habitat type (25 percent cover or 10-25 percent cover) was multiplied by the net annual production rate (g C/m²/yr; calculated above) for that habitat and adjusted to include the assumption that, during winter 60 percent of the habitat will occur under turbid ice, and 40 percent will occur under clear ice Dunton (1990).

3.1.2 Boulder Patch Map Development

To calculate the total area of each rock-cover category, a map of the recent rock-cover transect data (Coastal Frontiers Corporation and LGL Ecological Research Associates, Inc. 1998) was superimposed on the only available detailed map (Lee and Toimil 1985) which covers part of the area. Each of these investigators (Dunton, Gallaway, and Martin) independently interpreted the transect data to estimate the overall extent of the Boulder Patch, subdivided into areas containing 10 to 25% rock cover and >25% rock cover. The results were compared and the minor disparities were reconciled. In areas of where the investigators disagreed, the most recent data were used to resolve cases of conflict. Figure 1-1 represents the investigators' *best estimate* of the areal extent of the Boulder Patch kelp community for this assessment.

The estimated extents of the various habitat subdivisions were plotted on a map and their areas were measured using GIS procedures. For the purposes of this assessment, the Boulder Patch habitat (>10% rock cover) occupies about 64 km² (15,871 acres) of the Stefansson Sound seabed (Figure 1-1). About 52 percent (33.22 km²) of this community appears to have rock cover in excess of 25 percent, with the balance (48 percent or 31 km²) having rock cover between 10 and 25 percent. Therefore, total annual production for the area having greater than 25 percent rock cover is:

Rock Cover/Ice	Area (km ²)		Rate (g/m ² /yr)	=	Production (g C/yr)
>25%/Turbid (60%)	19.93	x	12.6	=	251.1 x 10 ⁶
>25%/Clear (40%)	<u>13.29</u>	x	19.9	=	<u>264.4 x 10⁶</u>
	33.22				515.5 x 10 ⁶

Habitats with 10 to 25 percent rock cover are also characterized by 60 percent occurring under turbid and 40 percent occurring under clear ice. The sum of the area by rate products is:

SECTION THREE

Effects of Altered Water Quality On Boulder Patch Kelp

<u>Rock Cover/Ice</u>	<u>Area (km²)</u>	<u>Rate (g/m²/yr)</u>	<u>Production (g C/yr)</u>
10-25%/Turbid (60%)	18.6	3.2	59.5 x 10 ⁶
10-25%/Clear (40%)	<u>12.4</u>	5.1	<u>63.3 x 10⁶</u>
	31.0		122.8 x 10 ⁶

The estimated base annual production of the entire Boulder Patch is thus on the order of 638 x 10⁶ g C per year (515.5 x 10⁶ + 122.8 x 10⁶ g C/yr). This value was used as the baseline for evaluating effects of project construction.

3.2 EFFECTS OF INCREASED TSS ON KELP PRODUCTIVITY

3.2.1 Assumptions

3.2.1.1 Winter Island Construction Assumptions

For this assessment it was assumed that Boulder Patch kelp present under the entire area of the modeled plume having >10 mg/L increase in TSS (Figure 2-1) will receive no winter light due to assimilation of suspended sediments from the island into the ice cover. The concentration of 10 mg/L was chosen arbitrarily to represent the threshold of impact because lesser concentrations are within the normal ambient range. While this may be an extremely conservative assumption, it is believed to be necessary given the absence of empirical data describing the relationship between TSS in the water column and corresponding opaqueness of the ice canopy. Annual net productivity associated with each rock-cover category (as calculated in Section 3.1) was reduced to productivity levels associated with turbid ice cover within the plume area. This provides an estimate of the effects from island construction on total kelp productivity attributable to loss of clear ice.

3.2.1.2 Pipeline Construction Assumptions

BPXA proposes to construct the pipeline during a winter season. A summer season scenario is included for the purposes of comparison only. In either case, it is assumed that sediment transport will always be directed towards the Boulder Patch, even though currents would be expected to flow in this direction only 70 percent (or less) of the time. The intent of this admittedly very conservative assumption is to ignore frequency and duration of exposure of the Boulder Patch to project-induced increases in TSS; i.e., in effect it was assumed that the predicted effects on productivity will be the result of the continuous presence of a TSS plume, instead of the short-term (1-2 day) "clouds" described in the Section 2.3.2.

For winter pipeline construction, the calculations assume that 100 percent of the area within the 10 mg/L XSS contour in Figure 2-2 will be covered by turbid ice. Therefore, annual net productivity associated with each rock cover category within the plume area was reduced to productivity levels associated with turbid ice cover.

For the summer pipeline construction scenario, it was assumed that the area potentially affected is enclosed by the 20 mg/L XSS contour shown in Figure 2-3. An XSS concentration of 20 mg/L was chosen as a conservative threshold because summer ambient XSS values are generally somewhat greater (see Section 2.1.1). Within the area enclosed by the 20 mg/L XSS contour, the calculations assume that annual kelp productivity will be reduced by 65 percent as based on rationale presented by Dunton (1990).

There is a direct linear relationship between annual growth or productivity of kelp and the duration of time (hours) that the plants are exposed to their summer photosaturation level of light, or H_{sat} (Dunton 1990). H_{sat} duration at three sites measured over four consecutive years (1986-1989) averaged 99 hours with the 95 percent confidence interval between 74 and 124 hours (data from Table 3 in Dunton 1990). To err on the conservative side, the lower limit of H_{sat} (74 hours) was used as the base condition to evaluate effects. At H_{sat} values at and above 100 hours, the maximum annual kelp growth achievable is 30 cm. It was assumed that light within the 20 mg/L XSS contour associated with summer pipeline construction will be reduced by 24 hours (a 12 hour "day" length times 2 days of exposure) reducing H_{sat} to 50 hours². At an H_{sat} level of 50 hours, annual linear kelp growth is predicted to be 11 cm (Dunton 1990). This implies an approximately 65 percent reduction in kelp growth as compared to that which would occur under ideal conditions.

3.2.1.3 Sedimentation From Stockpile Zone 1

A large spatial perturbation potentially resulting in decreases of light reaching the kelp in summer is likely to be associated with the dispersal of the sediments excavated from the pipeline trench during winter and disposed on the ice in Stockpile Zone 1. When the ice melts, and these materials fall to the seabed, they will be dispersed by the prevailing currents. The area subject to excess suspended sediment from the dispersal of this material is shown in Figure 2-4. Using the rationale described above for summer pipeline construction effects, it is assumed that Boulder Patch productivity within the area bounded by the 20 mg/L TSS increase contour shown on Figure 2-4 will be reduced by 65 percent.

3.2.2 Effects

As described in Section 3.2.1, it was assumed that 100 percent (versus a baseline condition of 60 percent) of the Boulder Patch habitat beneath the projected turbidity clouds or plume from the island and/or pipeline construction will occur under turbid ice. Using this assumption, the total annual production rates for the Boulder Patch were recalculated. To determine the open-water season effects, the productivity rate associated with each habitat within the specified zones was reduced by 65 percent, and the total annual production was recalculated on this basis. Percent reduction in productivity was calculated as the difference between the base production level and the reduced production level, divided by the base production level. The results of the

² Although there is more than 12 hours of daylight during the summer at this location, the sun is too low in the sky to enable attainment of H_{sat} for much of this time.

calculations are provided below for the Base Case, the Single Season option, and the Summer Pipeline Construction option.

3.2.2.1 Base Case

Under the Base Case, Liberty Island will be constructed during the first winter. No construction activity will occur during the following summer, and the pipeline will be installed during the second winter. Excess sediment from pipeline trench excavation will be consolidated and stockpiled on the ice at Stockpile Zone 1. At break-up following the winter of pipeline construction any sediments remaining on the ice will fall to the seabed. An unknown percentage will likely be dispersed while falling through the water column. It is highly unlikely that stockpiled sediments reaching the seafloor will be subsequently resuspended and transported to the Boulder Patch (see Section 2.3.4.2)

The XSS plume with concentration >10 mg/L from winter island construction will affect only about 0.3 km² of Boulder Patch habitat that has more than 25 percent rock cover (Figure 2-1, Table 3-1.A). Assuming that turbid ice develops over all this area, net annual production will be reduced by about 0.1 percent from that occurring under undisturbed conditions. Slope protection and a geo-textile cover of the island will prevent significant island erosion and XSS during the following open-water season. Some sediment fines might be released during reworking and grooming of the island slopes; however, these effects are expected to be short term (1-2 days) and quickly dissipated by currents.

Winter installation of the pipeline is estimated to reduce annual productivity by an estimated 4 percent (Table 3-1.B). A total of about 15 km² of Boulder Patch lies within the predicted "cloud" paths having a concentration of >10 mg/L, including 7 km² of habitat having rock cover more than 25 percent (see Figure 2-2).

The area which could potentially receive XSS from Stockpile Zone 1 extends to the Boulder Patch (see Figure 2-4), affecting about 4 km² of habitat, 0.5 km² of which exhibits <25 percent boulder cover (Table 3-1.C). Given the previously-stated assumptions, total Boulder Patch production will be decreased due to this plume by about 2 percent.

Under the Base Case, kelp productivity would be minimally reduced due to winter island construction activities. The reduction is likely to be within levels of natural variation. Pipeline installation activities in Year 2 could reduce annual productivity by about 4 percent. In Year 3, the kelp could experience a 2 percent reduction in productivity during the summer growth season due to sediment disposal from Stockpile Zone 1 (Figure 3-1). These effects are not cumulative but are spread over two consecutive growth years, with the reductions ranging from 2 to 4 percent per year.

3.2.2.2 Single Season Option

This construction scenario differs from the Base Case only in that both Liberty Island and the pipeline will be constructed during the same winter season. However, island construction effects on the Boulder Patch are expected to be very small; therefore, as with the Base Case, winter construction effects could result in about a 4 percent reduction in annual productivity for Year 1,

followed by another 2 percent reduction for Year 2 due to dispersal of stockpiled sediments (Figure 3-1 and Table 3-2).

3.2.2.3 Summer Pipeline Construction Option

Kelp production during the Year 1 is expected to be minimally reduced by winter construction of the island (Figure 3-1 and Table 3-3.A). However, summer pipeline construction activities could affect almost 13 km² of Boulder Patch habitat (Figure 2-3). The threshold concentration of XSS considered for this potential construction effect is 20 mg/L because ambient TSS levels are higher during the open-water season (see Section 2.1.1). The effects of construction induced suspended sediments could result in a 13 percent reduction in kelp productivity during the second kelp growth season following the beginning of construction activities. This is almost seven times the summer effect due to melting of the stockpile as expected for the other options. In addition, the assessment does not consider how the excess excavated materials will be handled. If these materials are returned to the water column at the construction site, a larger area could potentially be affected.

FIGURE 3-1 CONSTRUCTION EFFECTS RELATED TO KELP GROWTH YEAR

KELP GROWTH YEAR

	Summer Year 1	Winter Year 1	Summer Year 2	Winter Year 2	Summer Year 3
Base Case	No Construction	March-May	No Construction	March-May	June
		Island Construction		Pipeline Construction	Stockpile Disposal
		0.1 % reduction*		4% reduction*	2% reduction
Single Season	No Construction	March-May	June		No Construction
		Island Construction	Stockpile Disposal		
		Pipeline Construction	2% reduction*		
4% total reduction*					
Summer Option	No Construction	March-May	July-August		No Construction
		Island Construction	Pipeline Construction		
		0.1% reduction*	13% reduction*		

*Potential reduction in productivity for Boulder Patch community as mapped in Figure 1-1.

SECTION THREE

Effects of Altered Water Quality On Boulder Patch Kelp

Table 3-1. Base Case: Net reduction over the entire Boulder Patch and estimated worse case reductions in production associated with Liberty Development Project construction activities.

A) Effects of winter Island construction

	Boulder Patch		Island Construction		
	Area (km ²)	Net Production x 10 ⁶ g C yr ⁻¹	Affected Area (km ²)	Production loss x 10 ⁶ g C yr ⁻¹	% C Reduction
Rock cover					
>25% with turbid ice	19.93	251.1	0.17	0.0	0.00%
>25% with clear ice	13.29	264.4	0.11	0.8	0.13%
10-25% with turbid ice	18.60	59.5	0.00	0.0	0.00%
10-25% with clear ice	12.40	63.3	0.00	0.0	0.00%
Totals	64.22	638.3	0.28	0.8	0.13%

B) Effects of winter pipeline construction

	Boulder Patch		Winter Pipeline Construction		
	Area (km ²)	Net Production x 10 ⁶ g C yr ⁻¹	Affected Area (km ²)	Production loss x 10 ⁶ g C yr ⁻¹	% C Reduction
Rock cover					
>25% with turbid ice	19.93	251.1	4.14	0.0	0.0%
>25% with clear ice	13.29	264.4	2.76	20.1	3.1%
10-25% with turbid ice	18.60	59.5	5.09	0.0	0.0%
10-25% with clear ice	12.40	63.3	3.39	6.4	1.0%
Totals	64.22	638.3	15.38	26.5	4.1%

C) Effects from increased sedimentation from Stockpile Zone 1 - Summer

	Boulder Patch		Stockpile Zone 1 Plume		
	Area (km ²)	Net Production x 10 ⁶ g C yr ⁻¹	Affected Area (km ²)	Production loss x 10 ⁶ g C yr ⁻¹	% C Reduction
Rock cover					
>25%	33.22	515.5	0.50	5.1	0.88%
10-25%	31.00	122.8	3.25	8.4	4.1% 1.3%
Totals	64.22	638.3	3.75	13.5	2.1%

SECTION THREE

Effects of Altered Water Quality On Boulder Patch Kelp

Table 3-2. Single Season Option: Net production over the entire Boulder Patch and estimated worse case reductions in production associated with Liberty Development Project construction activities.

A) Effects of same winter construction of both the island and the pipeline

Rock cover	Boulder Patch		Island & Pipeline Construction		
	Area (km ²)	Net Production x 10 ⁶ g C yr ⁻¹	Affected Area (km ²)	Production loss x 10 ⁶ g C yr ⁻¹	% C Reduction
>25% with turbid ice	19.93	251.1	4.30	0.0	0.0%
>25% with clear ice	13.29	264.4	2.90	21.2	3.3%
10-25% with turbid ice	18.60	59.5	5.09	0.0	0.0%
10-25% with clear ice	12.40	63.3	3.39	6.4	1.0%
Totals	64.22	638.3	15.68	27.6	4.3%

B) Effects from increased sedimentation from Stockpile Zone 1 - Summer

Rock cover	Boulder Patch		Stockpile Zone 1 Plume		
	Area (km ²)	Net Production x 10 ⁶ g C yr ⁻¹	Affected Area (km ²)	Production loss x 10 ⁶ g C yr ⁻¹	% C Reduction
>25%	33.22	515.5	0.50	5.1	0.8%
10-25%	31.00	122.8	3.25	8.4	1.3%
Totals	64.22	638.3	3.75	13.5	2.1%

Table 3-3. Summer Pipeline Construction Option: Net production over the entire Boulder Patch and estimated worse case reductions in production associated with Liberty Development Project construction activities.

A) Effects of winter Island construction

Rock cover	Boulder Patch		Island Construction		
	Area (km ²)	Net Production x 10 ⁸ g C yr ⁻¹	Affected Area (km ²)	Production loss x 10 ⁸ g C yr ⁻¹	% C Reduction
>25% with turbid ice	19.93	251.1	0.17	0.0	0.0%
>25% with clear ice	13.20	264.4	0.11	0.8	0.13%
10-25% with turbid ice	18.60	59.5	0.00	0.0	0.0%
10-25% with clear ice	12.40	63.3	0.00	0.0	0.0%
Totals	64.22	638.3	0.28	0.8	0.13%

B) Effects of summer pipeline trenching and filling

Rock cover	Boulder Patch		Summer Pipeline Construction		
	Area (km ²)	Net Production x 10 ⁸ g C yr ⁻¹	Affected Area (km ²)	Production loss x 10 ⁸ g C yr ⁻¹	% C Reduction
>25% with turbid ice	33.22	515.5	6.20	62.6	9.8%
10-25% with turbid ice	31.00	122.8	6.60	17.0	2.7%
Totals	64.22	638.3	12.80	79.6	12.5%

4.1 SUMMARY OF PREDICTED EFFECTS

Table 4-1 summarizes the extent and duration of construction-induced excess suspended sediment concentrations on the Boulder Patch. For both Base Case and Single Season construction options, kelp productivity reductions are estimated to be 2-4% per year, which is not cumulative. For the Summer Pipeline Construction option, the corresponding reduction is 13%. These effects are expected to be temporary and of short duration as described below in Section 4.2. However, as low as they are, even these numbers should be regarded as very conservative, (i.e., an over-estimate of effects) because they result from a compounding of conservative assumptions taken in estimates of both physical and biological effects. Table 4-2 summarizes the assumptions made in this assessment.

4.2 DURATION AND EXTENT OF ANTICIPATED EFFECTS

The rationale for claiming that the duration of the construction effects will be short-term is based on previous observations of kelp response to, and recovery from, naturally-occurring adverse conditions. In 1988, storm-induced decreases in water transparency during the summer open-water period resulted in significant reductions in kelp health (as reflected in tissue density and carbon content) and ultimately in plant growth and productivity throughout the Boulder Patch habitat (Dunton 1990). However, tissue density and carbon content returned to expected levels the following year (1989) as water transparency returned to normal levels (Dunton 1990). Since these plants are highly sensitive to changes in underwater irradiance, they respond quickly to increases in water transparency. Impacts to kelp productivity are thus typically short-term and limited to the period characterized by low light.

In the natural environment, variations in kelp productivity due to the occurrence of turbid ice or intense storm and wind events are common, and are reflected in the heterogeneity of the Boulder Patch community. As described above, these natural events have not resulted in long-term, community-wide effects. Similarly, because construction-related impacts will be limited to a maximum of 2 years, there is no reason to expect that these impacts will result in long-term damage to the Boulder Patch kelp community.

Table 4-1 Summary of Predicted Effects of Construction-Induced Excess Suspended Sediments

	Description	10-25 % Boulder Cover		> 25% Boulder Cover		Duration and Season of Exposure	Potential Productivity Reduction
		Area (km ²)	Percent of total	Area (km ²)	Percent of total	(Days)	(%)
Base	Winter island and pipeline construction not concurrent, + stockpile dispersal during sea ice breakup	0 (island) 8.5 (pipeline) 3.3 (stockpile)	0 27 11	0.3 (island) 6.9 (pipeline) 0.5 (stockpile)	0.9 21 2	45 (winter) 1-2 (winter)* 1-2 (spring)*	0.1 (island) 4 (pipeline) 2 (stockpile)
Single Season Option	Winter island and pipeline construction concurrent + stockpile dispersal during sea ice breakup	8.5 (island and pipeline) 3.3 (stockpile)	27 11	7.0 7.2 (island and pipeline) 0.5 (stockpile)	21 2	45 (winter) 1-2 (spring)*	4 (island and pipeline) 2 (stockpile)
Summer Pipeline Construction	Winter island construction, summer pipeline construction, quantity and method of dredged materials disposal undetermined	0 (Island) 6.6 (Pipeline)	0 21	0.1 0.5 (Island) 6.2 (Pipeline)	0.03 0.09	45 (Winter) 1-2 (Summer)*	0.05 0 (Island) 13 (Pipeline)

*Duration Of Exposure At Any Given Point As The Sediment Clouds Move Over The Boulder Patch.

Table 4.2 Summary of Assumptions

Assumption	Why Considered Conservative
XSS Concentration - Island Construction	
1) 12 % of the fill materials will be resuspended during placement.	This estimate is based on experience placing fill during open-water conditions with associated wind and wave action. Placement through sea ice cover will result in less resuspension of material and a lower initial XSS concentration.
2) The fill material will fall through 6.1 m of water	ice cover will be present to lessen effective water depth; material will fall out closer the source.
3) Current will carry the suspended matter in a westerly direction towards the Boulder Patch for the entire construction period of 45 days	Currents in the region are westerly only 60-70% of the time; a more likely exposure would be about 30 days of the construction period.
XSS Concentration - Pipeline Construction Winter or Summer	
1) Initial XSS concentration will be 1,000 mg/L	No empirical data for pipeline construction exist; however, observations during the test trenching study at Northstar showed a TSS concentration of 885 mg/L near the seabed.
2) All material will move directly toward the Boulder Patch	Currents in the region are westerly 60-70% of the time; therefore it is expected that some of the material (30 to 40%) will move in the opposite direction away from the community.
XSS Concentration - Stockpiled Material	
1) 84,100 m3 of materials will be released to the water column at breakup	This is the maximum amount of material that could be stored at the disposal sites. The actual amount could be much less since the construction plan is to reuse the dredged materials in a continuous haul operation.
2) All material will be released to the water column in a 24 hr period.	Initial XSS concentration would be less if material melted over a longer period of time and was dispersed more quickly.
3) 10 % of the material will be entrained as it falls to the seabed.	If the material remains frozen and falls in clumps, this number could be much less.
4) Initial XSS concentration at Zone 1 will be 1,168 mg/L	Concentration would be less if less material is stored in Zone 1 and if material takes longer to melt.
Effects of Increased TSS - Winter Island and Pipeline Construction	
1) Boulder Patch Kelp present under the entire area having >10 mg/L increase in TSS from either winter pipeline or island construction will receive no winter light	The concentration of TSS in the water column required to create cloudy ice is not known. 10% was chosen since this is similar to TSS levels under ice in the region. It may be that much more TSS is required to form turbid ice, or that the TSS is entrained in a random pattern and the cloudy ice will not cover 100% of the area.
Effects of Increased TSS - Stockpile Melting and Summer Pipeline Construction	
1) The area potentially affected corresponds to the 20 mg/L XSS contour	This concentration is on the low end of expected ambient summer TSS levels. Observations have shown summer concentrations to average 45 mg/L.
2) Kelp productivity within the 20 mg/L XSS contour will be reduced by 65 %	To determine this reduction an H_{sat} of 1/4 hr, representing the lower boundary of the 95% confidence level for average H_{sat} was used. By using the average H_{sat} of 99 hr, a lower percent reduction (49%) is obtained.
	A reduction of 65% also assumes that the TSS "cloud" will pass over the area at the most optimal time for photosynthesis. However, the TSS "cloud" could pass by on a cloudy day or at a time when H_{sat} would not be achieved anyway.

- Berry, A.D., and J.M. Colonell. 1985. Prudhoe Bay Waterflood Project Seawater Treatment Plant: Main Outfall Dispersion Study, 9-19. April 1985. Prepared for ARCO Alaska Inc. by Entrix Inc., Anchorage, AK. August 1985.
- Britch, R.P., R.C. Miller, J.P. Downing, T. Petrillo, and M. Vert. 1983. Volume II physical processes. In B.J. Gallaway and R.P. Britch (eds.). Environmental Summer Studies (1982) for the Endicott Development. LGL Alaska Research Associates, Inc. and Harding Technical Services. Report for SOHIO Alaska Petroleum Company, Anchorage, Alaska. 219 pp.
- BP Exploration (Alaska) Inc., Liberty Development Project Development and Production Plan. 1998.
- Coastal Engineering Research Center. 1984. Shore Protection Manual, 2 vols., Dept. of the Army, Waterways Experiment Station, Corps of Engineers, Vicksburg MS.
- Coastal Frontiers, Inc. and LGL Ecological Research Associates. 1998. Liberty Development 1997-98 Boulder Patch Survey. Final Report. Prepared for BP Exploration (Alaska) Inc. Anchorage, AK.
- Dames & Moore. 1988. Lisburne Offshore Project Environmental Assessment. Prepared for ARCO Alaska, Inc., Exxon USA, and Standard Alaska Production Company by Dames & Moore, Anchorage, Alaska.
- Duane Miller & Associates. 1998. Geotechnical Exploration, Liberty Development, North Slope, Alaska. Prepared for BP Exploration Alaska.
- Dunton, K.H. 1984. An annual carbon budget for an arctic kelp community. Pp. 311-326 in P. Barnes, D. Schell, and E. Reimnitz (eds.), The Alaska Beaufort Sea ecosystem and environment. Academic Press, Orlando.
- Dunton, K.H. 1990. Growth and production in *Laminaria solidungula*: relation to continuous underwater light levels in the Alaskan High Arctic. Marine Biology 106:297-304.
- Dunton, K.H., and C.M. Jodwalis. 1988. Photosynthetic performance of *Laminaria solidungula* measured in situ in the Alaskan High Arctic. Marine Biology 98:277-285.
- Dunton, K.H., and D.M. Schell. 1986. A seasonal carbon budget for the kelp *Laminaria solidungula* in the Alaskan High Arctic. Mar. Ecol. Prog. Ser. 31:57-66.
- Dunton, K.H. and S.V. Schonberg. 1981. Ecology of the Stefansson Sound kelp community: II. Results of *in situ* and benthic studies. In: A.C. Broad et al., Environmental assessment of selected habitats in the Beaufort and Chukchi littoral system. Annual Report, April 1981, in Environmental Assessment of the Alaskan Continental Shelf. NOAA Environmental Research Labs., Boulder, CO. 65 pp.
- Dunton, K.H., Reimnitz, E., and S.V. Schonberg. 1982. An arctic kelp community in the Alaskan Beaufort Sea. Arctic 35:465-484.
- LGL Alaska Research Associates, Inc.; Applied Sociocultural Research; and Woodward-Clyde Consultants. 1998. Final Environmental Report, Liberty Development Project.

- Martin, L.R., and B.J. Gallaway. 1994. The effects of the Endicott Development Project on the Boulder Patch and arctic kelp community in Stefansson Sound, Alaska. *Arctic* 47(1):54-64.
- Minerals Management Service. 1996a. Beaufort Sea planning area oil and gas lease sale 144. Final Environmental Impact Statement. MMS OCS EIS/EA MMS 96-0012. U.S. Dept. of Interior, MMS, Alaska Outer Continental Shelf Region, Anchorage, AK.
- Montgomery Watson. 1996. Northstar Development Project pilot Offshore Trenching Program, Data Report. Prepared for BP Exploration (Alaska) Inc., by Montgomery Watson, Anchorage, Alaska.
- Montgomery Watson. 1997. Liberty Island route water/sediment sampling. Prepared for BP Exploration (Alaska) Inc., P.O. Box 196612, Anchorage, AK 99519-6612.
- Montgomery Watson. 1998. Liberty Island Route Water/Sediment Sampling Revised and Corrected Final Data Report. Prepared for BP Exploration (Alaska). August 1998.
- Reimnitz, E. and L. Toimil. 1976. Diving notes from three Beaufort Sea sites. *In:* P. Barnes and E. Reimnitz. Geologic Processes and Hazards of the Beaufort Sea Shelf and Coastal Regions. Quarterly Report, December 1976. Nat. Oceanic Atmos. Admin., Boulder, CO. Attachment J. 7 pp.
- U.S. Army Corps of Engineers (USACE). 1987. 1985 Final Report for the Endicott Monitoring Program, Volume 3, Oceanographic Monitoring. Prepared by EnviroSphere Company, Anchorage, AK, for the U.S. Army Corps of Engineers, Alaska District.
- U.S. Army Corps of Engineers. 1990. 1986 Final Report for the Endicott Monitoring Program, Volume 2, Oceanography. Prepared by EnviroSphere Company, Anchorage, AK, for the U.S. Army Corps of Engineers, Alaska District.
- U.S. Army Corps of Engineers. 1991. 1987 Final Report for the Endicott Monitoring Program, Volume 2, Oceanography. Prepared by Science Applications International Corporation, Anchorage, AK, for the U.S. Army Corps of Engineers, Alaska District.
- U.S. Army Corps of Engineers. 1992. 1988 Final Report for the Endicott Monitoring Program, Volume 2, Oceanography. Prepared by Science Applications International Corporation, Anchorage, AK, for the U.S. Army Corps of Engineers, Alaska District.
- U.S. Army Corps of Engineers. 1993. 1989 Final Report for the Endicott Monitoring Program, Volume 2, Oceanography. Prepared by Science Applications International Corporation, Anchorage, AK, for the U.S. Army Corps of Engineers, Alaska District.
- URS Greiner Woodward Clyde. 1999. Liberty Development Water Quality Study. Draft report in preparation for BP Exploration (Alaska) Inc. November, 1998
- Woodward-Clyde Consultants. 1982. Construction Verification for Tern Island. Prepared by WCC for Shell Oil Company, Anchorage, Alaska.

Appendix A
Transport of Re-suspended Sediments

Appendix A

Transport of Resuspended Sediments

Purpose

The overall purpose of this analysis is to determine the fate of sediments that are re-suspended in the water column by construction activities. Re-suspension occurs (1) when finer sediments are washed out of excavated soil and gravel that is dropped or transported through the water column, and (2) when excavation procedures disturb the seabed. As the re-suspended ("excess") sediment is transported away from the excavation site by the ambient current, it also settles to the seabed such that its concentration in the water column decreases with distance from the excavation site. Of concern is the amount of excess suspended sediment (XSS) that remains in the water column as it is transported to and over the Boulder Patch and the extent to which that XSS interferes with light available to fuel growth of the kelp community.

The analytical objective is to determine the water column concentration of *excess* suspended sediment (XSS) that occurs as a result of construction activity. By "excess" is meant the concentration of suspended sediment *above ambient*, or natural, level at the location in question for the season and weather conditions. By determining XSS as a function of distance from the point of introduction (i.e. island, pipeline trench, etc.), it is then possible to estimate both areal and temporal exposures of any portion of the Boulder Patch kelp community to the additional sediment introduced by construction activities.

Analysis

For all cases the first step is to determine the *initial concentration* of sediments at the point of introduction, hereafter referred to as the "source." This requires identification of the hydrodynamic mechanisms by which sediments are introduced into the water column, culminating in an *assumption* of the percentage of the finer particles that are actually introduced as a result of the construction activity. While the best knowledge of the hydrodynamics of each situation has been incorporated in the analysis, it is important to emphasize that the percentages assumed for introduction of sediments are estimates only, because there are very few experimental data available to verify the computations. Thus the net mass rate M_s of sediment discharged to water column is determined by

$$M_s = 0.01 p M \quad (1)$$

in which p is the assumed percentage of total excavated sediment mass M that is liberated and re-suspended by excavation operations.

The initial concentration C_o is determined by dividing M_s by the volumetric rate of flow Q_f past the point of discharge; i.e.

$$C_o = M_s / Q_f \quad (2)$$

But Q_f is equal to the product of the current speed U and the local depth H , so equation (2) becomes

$$C_o = M_s / UH \quad (3)$$

For simplicity, the initial concentration and all subsequent sediment concentrations are assumed to be uniform over the depth of the water column. Once the initial concentration of sediments is determined, the next step is to compute concentration as a function of distance from the source.

Appendix A

Transport of Resuspended Sediments

As the sediment particles are transported horizontally by the prevailing current, the force of gravity causes them to fall to the seabed. The combination of horizontal and vertical components of velocity causes each particle to follow a downward sloping linear trajectory from the source to the seabed some distance down current. Accordingly, the concentration of suspended sediment, averaged over the water column, decreases steadily until it reaches zero, which occurs when the "last" particle settles on the seabed.

Sediment particles fall through the water column with vertical ("settling") velocities that depend on individual particle size and density, as well as the viscosity of the water. For a particle from the n^{th} size fraction (of several sizes represented in a soil sample), the maximum time T_n , required for the particle to fall to the seabed is given by

$$T_n = H / V_n \quad (4)$$

in which V_n is the settling velocity for that particle size. During its fall to the seabed, the particle will travel a horizontal distance X_n given by

$$X_n = U T_n \quad (5)$$

or,
$$X_n = U H / V_n \quad (6)$$

While both velocity components, U and V_n , might fluctuate due to water column turbulence or wave motion, only their *mean* values are relevant to this analysis. The mean horizontal component of particle velocity is simply the mean current speed and direction. The mean vertical velocity component is the particle "settling" velocity, which is determined by the particle size and the hydrodynamics of flow around the particle as it falls through the water column.

The settling velocity appropriate to each particle size is assumed to equal the "terminal" velocity of a sphere having the same nominal diameter and density as the particle. An object falls through a viscous fluid at (constant) terminal velocity when the fluid drag on the object is exactly balanced by the weight of the object in that fluid. Different hydrodynamic regimes govern the flow pattern according to the object size and viscosity of the surrounding fluid.

The hydrodynamics of flow around objects can be categorized by the Reynolds number R , which indicates the relative importance of gravitational and viscous forces, and is given by

$$R = D V / \nu \quad (7)$$

in which D is the nominal diameter of the object, V is the flow velocity relative to the object, and ν is the kinematic viscosity of the fluid. Flows dominated by viscous effects are characterized by small values of the Reynolds number ($R < 1,000$ for spherical objects), while dominance of gravitational force is indicated by larger values of R . Under naturally occurring conditions, there are three hydrodynamic regimes for sediment particles falling through air or water:

- Very slow, "creeping", or "Stokes" flow, when $R < 1$
- Laminar flow, when $1 < R < 1,000$, and
- Turbulent flow, when $R > 1,000$

When the Reynolds number is less than unity, the "creeping" flow velocity relationship known as Stokes' Law applies:

Appendix A Transport of Resuspended Sediments

$$V = g (\rho_s / \rho_w - 1) D^2 / 18\nu \quad (8)$$

in which g is gravitational acceleration, ρ_s and ρ_w are, respectively, sediment and water densities (Blevins 1984).

For hydrodynamic conditions characterized by larger Reynolds numbers, the flow regime is either laminar or turbulent and the settling velocity is determinable from the general relationship for fluid drag on spherical objects, and is given by

$$V = [(4/3) (g / C_D) (\rho_s / \rho_w - 1)]^{1/2} \quad (9)$$

in which C_D is the fluid drag coefficient (Blevins 1984).

Application of equations (8) or (9) to each particle diameter, as determined from a grain size analysis of seabed soils, enables computation of settling velocities (Table A-1). Then the maximum horizontal transport of a sediment particle of given size, while falling to the seabed, can be computed (Equation 6) for any specified current speed and water depth (Table A-2).

Computation of total XSS concentration as a function of distance from the source is then an accounting of the quantity of each sediment fraction remaining in the water column at any specified distance, and summing those quantities to determine the total remaining. For the n^{th} sediment fraction (i.e. with diameter D_n and initial concentration of C_{0n} , the concentration in the water column at any distance x from the source is

$$C_n(x) = C_{0n} [1 - x / (UT_n)] \quad \text{for } x \leq UT_n \quad (10a)$$

and

$$C_n(x) = 0 \quad \text{for } x > UT_n \quad (10b)$$

The total XSS concentration is the sum of all remaining sediment fraction amounts in the water column, or

$$C(x) = \sum C_n(x) \quad \text{summed for all sediment fractions} \quad (11)$$

The foregoing analytical scheme was incorporated in a spreadsheet to compute XSS concentrations as a function of distance from the site of each construction activity. Results were then mapped to determine areal extent of impingement on the Boulder Patch.

Table A-1. Settling velocities for Liberty Development seabed sediments

Sediment Properties*				Sediment Particle Hydrodynamics			
Sediment Fraction	Particle Diameter (mm)	Mass Fraction (%)	Specific Gravity	Reynolds Number	Flow Type	Drag Coefficient	Settling Velocity (m/s)
1	0.005	2	1.784	0.000013	Stokes		0.000005
2	0.020	21	1.784	0.000859	Stokes		0.000077
3	0.074	17	1.784	0.0435	Stokes		0.00106
4	0.149	42	1.784	0.355	Stokes		0.00429
5	0.420	5	1.949	1.18	laminar	2.05	0.0504
6	0.840	2	1.949	48	turbulent	1.00	0.102
7	2.00	3	1.949	248	turbulent	0.50	0.223
8	4.75	4	1.949	1,000	turbulent	0.41	0.379
9	9.50	4	1.949	2,870	turbulent	0.40	0.543

*Source: Duane Miller & Associates 1998

Appendix A
Transport of Resuspended Sediments

Table A-2. Maximum horizontal transport (m) as function of current speed and water depth

Sediment		Seasonal Current Speeds and Water Depths*					
Particle Diameter (mm)	Settling Velocity (m/s)	Winter 0.02 m/s		Breakup 0.05 m/s		Summer 0.10 m/s	
		1 m	4 m	1 m	4 m	3 m	6 m
		Maximum Horizontal Transport (m)					
0.005	0.000005	4,139	16,555	10,347	41,388	62,081	124,163
0.020	0.000077	259	1,035	617	2,587	3,880	7,760
0.074	0.00106	19	76	47	189	283	567
0.149	0.00429	5	19	12	47	70	140
0.420	0.0504	<1	2	2	4	6	12
0.840	0.102	<1	<1	<1	2	3	6
2.00	0.223	<1	<1	<1	<1	2	3
4.75	0.379	<1	<1	<1	<1	<1	2
9.50	0.543	<1	<1	<1	<1	<1	2

*Water depths for winter and breakup indicate water column *beneath* 2m of solid or broken ice cover.

ADDENDUM:

CORRECTED TABLES 3-1, 3-2, and 3-3

Table 3-1. Base Case: Net reduction over the entire Boulder Patch and estimated worse case reductions in production associated with Liberty Development Project construction activities.

A) Effects of winter Island construction

Rock cover	Boulder Patch		Island Construction		
	Area (km ²)	Net Production x 10 ⁶ g C yr ⁻¹	Affected Area (km ²)	Production loss x 10 ⁶ g C yr ⁻¹	% C Reduction
>25% with turbid ice	19.93	251.1	0.17	0.0	0.00%
>25% with clear ice	13.29	264.4	0.11	0.8	0.13%
10-25% with turbid ice	18.60	59.5	0.00	0.0	0.00%
10-25% with clear ice	12.40	63.3	0.00	0.0	0.00%
Totals	64.22	638.3	0.28	0.8	0.13%

B) Effects of winter pipeline construction

Rock cover	Boulder Patch		Winter Pipeline Construction		
	Area (km ²)	Net Production x 10 ⁶ g C yr ⁻¹	Affected Area (km ²)	Production loss x 10 ⁶ g C yr ⁻¹	% C Reduction
>25% with turbid ice	19.93	251.1	4.14	0.0	0.0%
>25% with clear ice	13.29	264.4	2.76	20.1	3.1%
10-25% with turbid ice	18.60	59.5	5.09	0.0	0.0%
10-25% with clear ice	12.40	63.3	3.39	6.4	1.0%
Totals	64.22	638.3	15.38	26.5	4.1%

C) Effects from increased sedimentation from Stockpile Zone 1 - Summer

Rock cover	Boulder Patch		Stockpile Zone 1 Plume		
	Area (km ²)	Net Production x 10 ⁶ g C yr ⁻¹	Affected Area (km ²)	Production loss x 10 ⁶ g C yr ⁻¹	% C Reduction
>25%	33.22	515.5	0.50	5.1	0.8%
10-25%	31.00	122.8	3.25	8.4	1.3%
Totals	64.22	638.3	3.75	13.5	2.1%

Table 3-2. Single Season Option: Net production over the entire Boulder Patch and estimated worse case reductions in production associated with Liberty Development Project construction activities.

A) Effects of same winter construction of both the island and the pipeline

Rock cover	Boulder Patch		Island & Pipeline Construction		
	Area (km ²)	Net Production x 10 ⁶ g C yr ⁻¹	Affected Area (km ²)	Production loss x 10 ⁶ g C yr ⁻¹	% C Reduction
>25% with turbid ice	10.93	251.1	4.30	0.0	0.0%
>25% with clear ice	13.29	264.4	2.90	21.2	3.3%
10-25% with turbid ic	18.60	59.5	5.09	0.0	0.0%
10-25% with clear ice	12.40	63.3	3.39	6.4	1.0%
Totals	64.22	638.3	15.68	27.6	4.3%

B) Effects from increased sedimentation from Stockpile Zone 1 - Summer

Rock cover	Boulder Patch		Stockpile Zone 1 Plume		
	Area (km ²)	Net Production x 10 ⁶ g C yr ⁻¹	Affected Area (km ²)	Production loss x 10 ⁶ g C yr ⁻¹	% C Reduction
>25%	33.22	515.5	0.50	5.1	0.8%
10-25%	31.00	122.8	3.25	8.4	1.3%
Totals	64.22	638.3	3.75	13.5	2.1%

Table 3-3. Summer Pipeline Construction Option: Net production over the entire Boulder Patch and estimated worst case reductions in production associated with Liberty Development Project construction activities.

A) Effects of winter Island construction

Rock cover	Boulder Patch		Island Construction		
	Area (km ²)	Net Production x 10 ⁶ g C yr ⁻¹	Affected Area (km ²)	Production loss x 10 ⁶ g C yr ⁻¹	% C Reduction
>25% with turbid ice	19.93	251.1	0.17	0.0	0.0%
>25% with clear ice	13.29	264.4	0.11	0.8	0.13%
10-25% with turbid ice	18.00	59.5	0.00	0.0	0.0%
10-25% with clear ice	12.40	63.3	0.00	0.0	0.0%
Totals	64.22	638.3	0.28	0.8	0.13%

B) Effects of summer pipeline trenching and filling

Rock cover	Boulder Patch		Summer Pipeline Construction		
	Area (km ²)	Net Production x 10 ⁶ g C yr ⁻¹	Affected Area (km ²)	Production loss x 10 ⁶ g C yr ⁻¹	% C Reduction
>25% with turbid ice	33.22	515.5	6.20	62.6	9.8%
10-25% with turbid ice	31.00	122.8	6.60	17.0	2.7%
Totals	64.22	638.3	12.80	79.6	12.5%

ATTACHMENT C

Description of the SSFATE Numerical Modeling System



6-981109



Description of the SSFATE Numerical Modeling System

PURPOSE: This technical note describes the numerical modeling system SSFATE (Ssuspended Sediment FATE), which is being developed to compute suspended sediment fields resulting from dredging operations. Both theoretical aspects of the computations made within SSFATE and application aspects of the shell-based personal computer program are discussed.

BACKGROUND: SSFATE was developed in response to a need for tools to assist dredging project managers confronted by requests for environmental windows. Environmental windows, intended to protect biological resources or their habitats, are requested during the interagency coordination process for dredging projects (Reine, Dickerson, and Clarke 1998). In many cases, decisions regarding environmental windows must be based on limited technical information because potential impacts are linked to a host of site- and project-specific factors. For example, navigation dredging operations in different reaches of the same waterway may pose risks to different resources, or potential impacts may vary dependent on the type of dredge plant involved. Few tools exist to evaluate such concerns early in the environmental window negotiation process. Consequently, a general inability to address “What if” questions associated with given dredging project scenarios tends to ensure that recommended environmental windows are conservative, and perhaps over-restrictive (Reine, Dickerson, and Clarke 1998).

Some of the most frequently asked “What if” questions during dredging project coordination are related to resuspension and dispersion of sediments at the dredging site. Suspended sediments are a primary concern of resource agencies, as exposure of aquatic organisms to elevated suspended sediment concentrations is perceived to be a major source of detrimental impact. Likewise, redeposition of suspended sediments can be a significant concern if sensitive bottom-dwelling organisms (e.g., oysters or sea grasses) are present in the vicinity of a dredging project. Accurate information on the spatial dynamics of dredge-induced suspended sediments is therefore a critical necessity in establishing the overall need for protective windows.

Environmental windows are associated with a majority of dredging projects in many U.S. Army Corps of Engineers Districts (Reine, Dickerson, and Clarke 1998). However, presently available modeling tools for predicting suspended sediment behavior were not designed with environmental windows negotiation in mind. For logistical reasons, models that require complicated, extensive hydrodynamic databases, grid building, or high-end computer support are not suitable. These models are more appropriate for large, controversial projects. Clearly, funding constraints alone would hinder application of expensive numerical models to the evaluation of numerous environmental windows.

To be truly effective as a dredging project management tool with respect to windows, models should be capable of running multiple simulations in a relatively short span of time so that a number of alternative dredging scenarios can be evaluated to determine those with the least probabilities of

detrimental impacts. An ability to display the dispersion of suspended sediments from a dredging site in a format that can be merged with known distributions of biological resources is a requirement that powerfully enhances impact assessments. Also, a “hands-on” tool that would enable the dredging project manager or resource agency representatives to specify a range of simulated scenarios and have model solutions quickly and readily available for interpretation would be a significant improvement over existing technologies.

Given these considerations, SSFATE is being developed to fulfill an obvious need for a modeling tool that can be easily customized to simulate a broad spectrum of dredging scenarios, accommodating essentially any hydrodynamic setting and most typical dredge plants. SSFATE is not intended to be an analytical tool per se, but rather a screening tool. Its utility is particularly suited for assessing the likelihood that resuspended sediments generated by a specific project would pose substantial risk to resources or habitats of concern, thereby allowing environmental windows to be appropriately applied or modified. Obviously, if SSFATE output showed negligible overlap of suspended/deposited sediments and resource distributions, the need for a stringent window to avoid conflicts would be questionable. Conversely, where output from SSFATE indicated a high probability of impact, an individual window could be accepted with a higher degree of confidence in its technical justification, and lead to consideration of other means to minimize impacts.

SYSTEM OVERVIEW: SSFATE is a versatile computer modeling system containing many features. For example, ambient currents, which are required for operation of the basic computational model, can either be imported from a numerical hydrodynamic model or drawn graphically using interpolation of limited field data. Model output consists of concentration contours in both horizontal and vertical planes, time-series plots of suspended sediment concentrations, and the spatial distribution of sediment deposited on the sea floor. In addition, particle movement can be animated over Geographic Information System (GIS) layers depicting sensitive environmental areas.

SSFATE employs a shell-based approach consisting of a color graphics based, menu-driven user interface, GIS, environmental data management tools, gridding software, and interfaces to supply input and display output data from the model. SSFATE runs on a personal computer and makes extensive use of the mouse (point/click) and pulldown menus. Data input/output is interactive and mainly graphics based. The system supports a full set of tools to allow the user to import data from standard databases, a wide variety of GISs, and other specialized plotting/analysis programs. SSFATE can be set up to operate at any dredging operation site and includes a series of mapping/analysis tools to facilitate applications. Initial setup for new locations of dredging operations can normally be accomplished in a few hours, unless numerical hydrodynamic models are run to provide flow fields. At the heart of the system is a computational model that predicts the transport, dispersion, and settling of suspended dredged material released to the water column as a result of dredging operations. An integral component of the modeling system is the specification of the sediment source strength and vertical distribution.

SSFATE SEDIMENT SOURCES: At the present time, sediment sources in SSFATE represent the introduction of sediment into the water column only as the result of a cutterhead dredge, a hopper dredge, or a clamshell dredge. The strength of each source is based on the Turbidity Generation Unit concept proposed by Nakai (1978). For the cutterhead dredge source, introduction of

suspended material is assumed to occur very near the bottom. For dredging operations using a hopper dredge, both near-bottom and near-surface sources are modeled. Near-surface sources are needed if overflow operations are performed. Clamshell dredges release material continuously as the clamshell is pulled through the water column. Thus, the vertical distribution of suspended sediment released by a clamshell dredge extends over the entire water column. In addition, since overflow operations can occur with the placement of material into a barge using a clamshell dredge, a near-surface source is also implemented for clamshell dredges. A detailed discussion of the sediment sources in SSFATE is provided in Johnson and Parchure (1999).

Simulation durations with SSFATE are not anticipated to be greater than a day or so. Thus, although the sources for cutterhead and clamshell dredges can move during the day, the greatest movement of the sediment source will occur with a hopper dredge. To account for this movement, the user specifies a line along which dredging takes place at a specified rate. When the hoppers are full, the simulated dredge moves to the placement site and releases the material. When the dredge returns to the dredging site, a new dredging line is specified. This procedure continues until the simulation is completed.

COMPUTATIONAL MODEL: Depending on the resolution of the numerical grid employed, SSFATE can make predictions very near dredging operations; however, the processes modeled are primarily far field processes in which the mean transport and turbulence associated with ambient currents dominate. Transport and dispersion of suspended material from a sediment source are predicted by a particle-based model using a random walk procedure.

The following basic equations determine the location of each particle at the next time-step in the simulation:

$$X^{n+1} = X^n + DX \tag{1}$$

$$Y^{n+1} = Y^n + \Delta Y \tag{2}$$

$$Z^{n+1} = Z^n + \Delta Z \tag{3}$$

where

$$\Delta X = U\Delta T + L_x \tag{4}$$

$$\Delta Y = V\Delta T + L_y \tag{5}$$

$$\Delta Z = Ws_i\Delta T + L_z \tag{6}$$

and

X, Y, Z = location of particle in the x-, y-, and vertical directions, respectively

U, V = mean ambient velocity in the x-, and y-directions, respectively

ΔT = time-step

Ws_i = settling velocity of particle class i

L_x, L_y, L_z = particle diffusion distance in the x-, y-, z-directions, respectively

Particle diffusion is assumed to follow a simple random walk process. A diffusion distance defined as the square root of the product of an input diffusion coefficient and the time-step is decomposed into X and Y displacements via a random direction function. The Z diffusion distance is scaled by a random positive or negative direction. The equations for the horizontal and vertical diffusion displacements are written as:

$$L_x = \sqrt{D_h \Delta T} \cos(2\pi R) \quad (7)$$

$$L_y = \sqrt{D_h \Delta T} \sin(2\pi R) \quad (8)$$

$$L_z = \sqrt{D_z \Delta T} (0.5 - R) \quad (9)$$

where

D_h, D_z = horizontal and vertical diffusion coefficients, respectively

R = random real number between 0 and 1

The particle model allows the user to predict the transport and fate of classes of settling particles, e.g., sands, silts, and clays. The fate of multicomponent mixtures of suspended sediments is predicted by linear superposition. The particle-based approach is extremely robust and independent of the grid system. Thus, the method is not subject to artificial diffusion near sharp concentration gradients and is easily interfaced with all types of sediment sources. For example, although the basic purpose of SSFATE is to aid in answering questions concerning the need for environmental windows associated with a dredging operation, models such as STFATE (Short-Term FATE) (Johnson and Fong 1995), which computes the near field dynamics of a placement operation, could be used to provide the sediment source associated with placement operations. In addition, under the Dredging Operations and Environmental Research (DOER) Program, a near field model is being developed to answer mixing zone questions connected with the placement of dredged material by a pipeline. Plans call for implementing results from the pipeline model as a sediment source in SSFATE.

Equations 4-6 show that the components of the ambient current field are required to transport the sediment particles. SSFATE provides two options for the user. The simplest option is to input limited field data, e.g., the magnitude of the tidal current, its period, and its principal direction. An interpolation scheme described by Cressman (1959) is then employed to “paint” a flow field over a rectangular water-land numerical grid. This flow field is then used to provide the (U, V) components of the ambient current in Equations 4 and 5. With this option, there is no vertical component of the flow field. The second option is for the user to import a time-varying,

three-dimensional (3-D) flow field generated by a numerical hydrodynamic model such as CH3D (Curvilinear Hydrodynamics in 3 Dimensions) developed by Johnson et al. (1991).

As implied by these two options, two types of grids are allowed in SSFATE. If currents are painted, the grid is rectangular with rectangular cells that are either land or water cells. Figure 1 shows an example of such a grid generated for upper Narragansett Bay, Rhode Island.

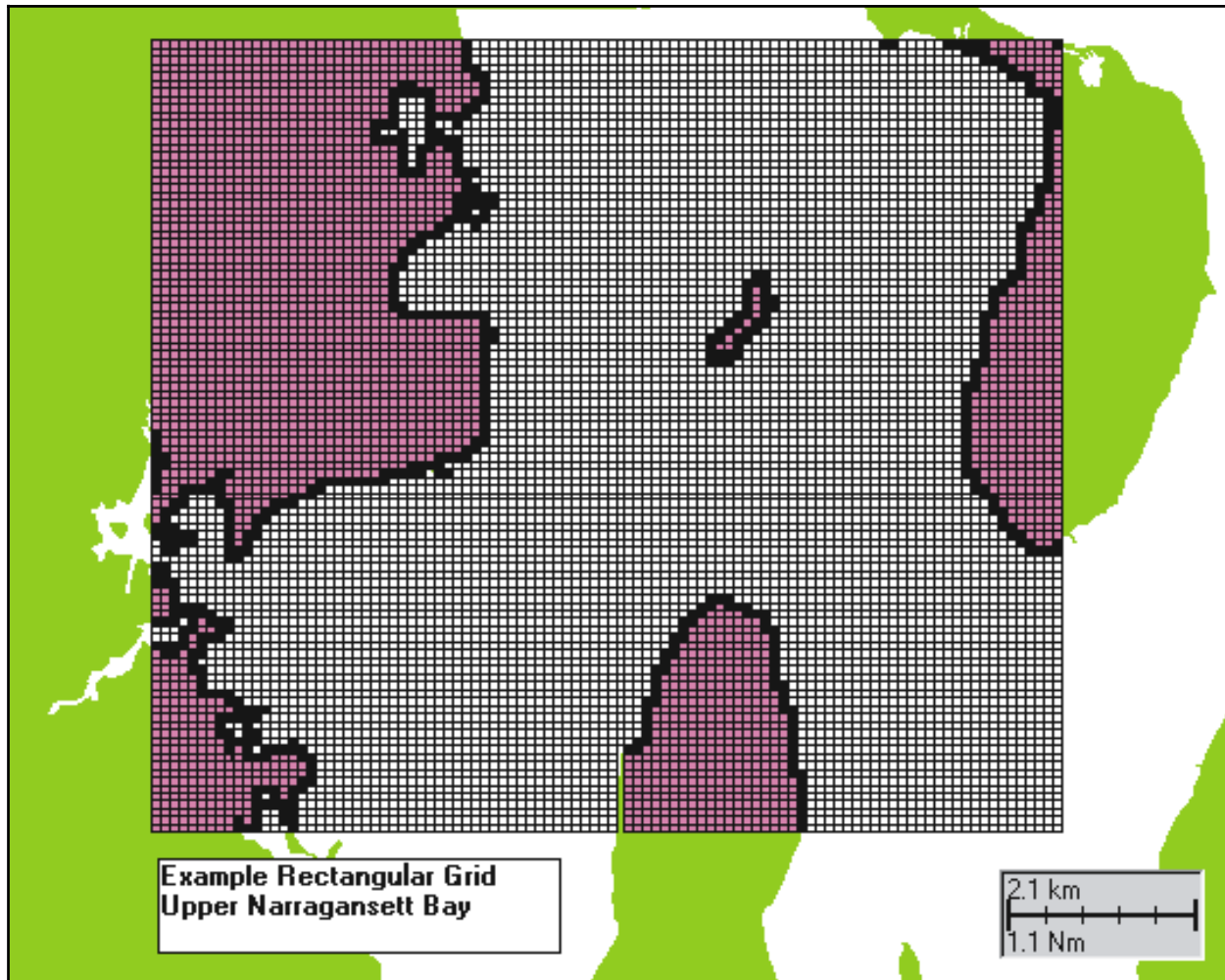

Figure 1. Rectangular land-water grid supported by SSFATE, upper Narragansett Bay, Rhode Island

However, if 3-D hydrodynamics are imported, SSFATE supports either a rectangular or a boundary-fitted curvilinear grid such as shown in Figure 2, again for the upper Narragansett Bay.

In addition to transport and dispersion, sediment particles also settle at some rate from the water column. Settling of mixtures of particles, some of which may be cohesive in nature, is a complicated process with the different size classes interacting; i.e., the settling of one particle type is not independent of the other types. The procedure that has been implemented in SSFATE is described in the following paragraphs, taken from Teeter (in review).

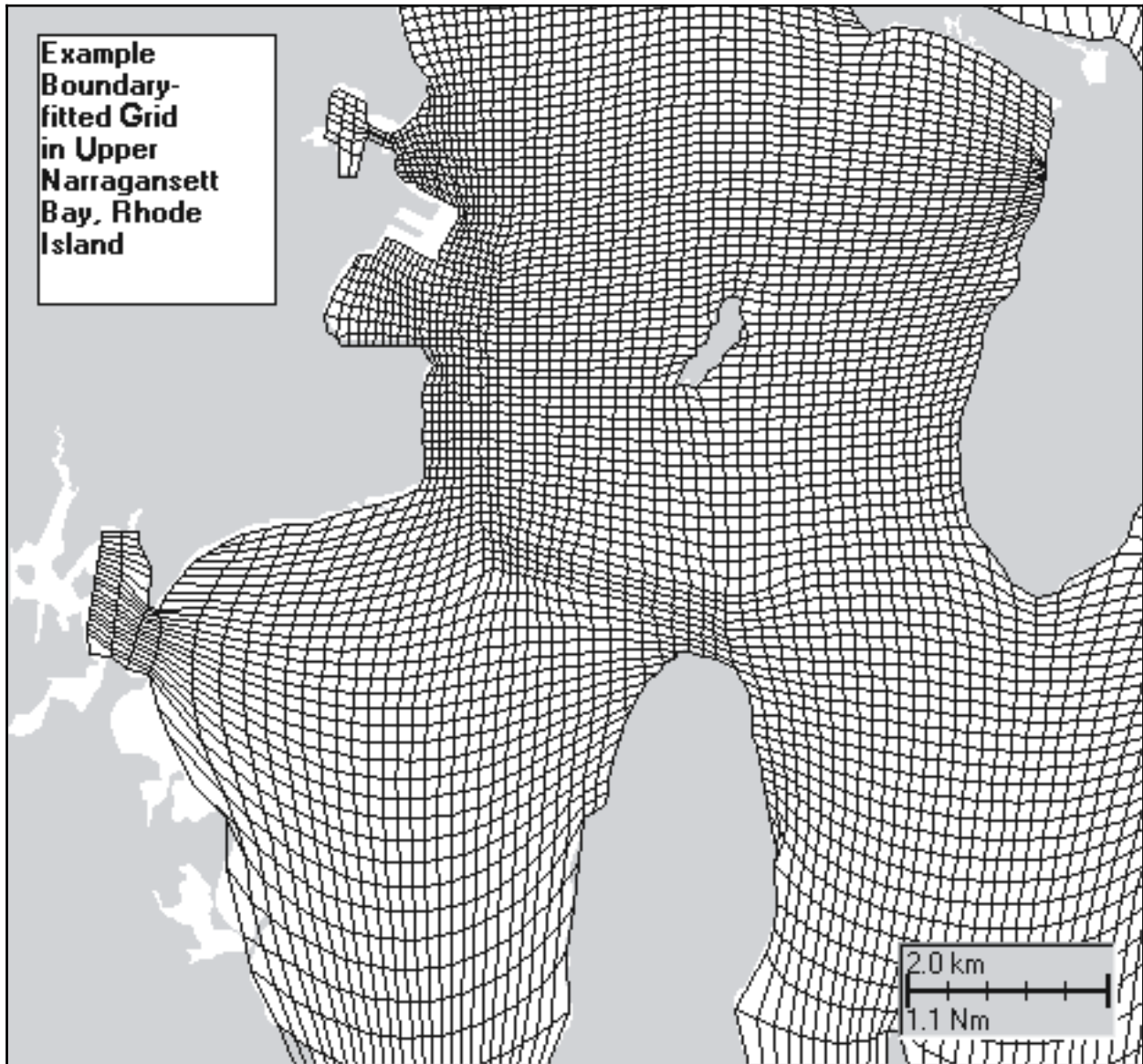

Figure 2. Boundary-fitted grid supported by SSFATE, upper Narragansett Bay, Rhode Island

At the end of each time-step the concentration of each sediment class C_i as well as the total concentration C is computed on a concentration numerical grid. The size of all grid cells is the same relative to one another and to time, with the total number of cells increasing as the suspended sediment plume moves away from the dredging source. The settling velocity of each particle size class is computed from

$$W_{s_i} = a \left(\frac{C}{C_{ul}} \right)^{n_i} \quad (10)$$

$$a = \frac{1}{C} \sum_i a_i C_i \quad (11)$$

$$\bar{C}_{ul} = \frac{1}{C} \sum_i C_{ul_i} C_i \quad (12)$$

$$\bar{C}_{ll} = \frac{1}{C} \sum_i C_{ll_i} C_i \quad (13)$$

and C_{ul_i} and C_{ll_i} are the nominal upper and lower concentration limits, respectively, for enhanced settling of grain class i .

If $C \geq \bar{C}_{ul}$ then

$$W_{s_i} = a \quad (14)$$

whereas, if $C \leq \bar{C}_{ll}$ then

$$W_{s_i} = a \left(\frac{\bar{C}_{ll}}{C_{ul}} \right)^{n_i} \quad (15)$$

Typical values of C_{ll_i} , C_{ul_i} , a_i , and n_i for four size classes are given in Table 1.

The next step in the settling computations is to compute a bottom shear

stress τ using either the painted currents or the imported currents. A deposition probability P_i is then computed for each size class as follows:

a. For size class 0 (clay), the following are used:

$$P_0 = \left(1 - \frac{\tau}{\tau_{cd}} \right), \text{ if } \tau < \tau_{cd} \quad (16)$$

$$P_0 = 0, \text{ if } \tau > \tau_{cd} \quad (17)$$

where τ_{cd} is the critical shear stress for deposition for the clay fraction.

Table 1					
Typical values of coefficients					
Class	Size, microns	C_{ll_i}, g/cc	C_{ul_i}, g/cc	a_i, m/s	n_i
0	0-7 (clay)	50	1000	0.0001	1.33
1	8-35 (fine silt)	150	3000	0.0002	1.10
2	36-74 (coarse silt)	250	5000	0.0005	0.90
3	75-130 (fine sand)	400	8000	0.010	0.80

b. For the other size classes, SSFATE uses

$$P_i = 0, \text{ if } \tau \geq \tau_{ul_i} \quad (18)$$

$$P_i = 1.0, \text{ if } \tau \leq \tau_{\ell\ell_i} \quad (19)$$

where

τ_{ul_i} = the shear stress above which no deposition occurs for grain class i

$\tau_{\ell\ell_i}$ = the shear stress below which the deposition probability for grain class i is 1.0

For values of τ between $\tau_{\ell\ell_i}$ and τ_{ul_i} , linear interpolation is used.

Typical values for $\tau_{\ell\ell}$, and τ_{ul} are given in Table 2.

Class	$\tau_{\ell\ell_i}$	τ_{ul_i}
0	0.016	0.03
1	0.03	0.06
2	0.06	0.20
3	0.20	0.90

A typical value for τ_{cd} is 0.016 Pa.

Next, the deposition of sediment from each size class from each bottom cell during the current time-step is computed. The computations start with the largest size class:

$$Flux_i = b_i C_i Ws_i P_i \quad (20)$$

where b_i is a probability parameter that includes all other factors influencing deposition other than shear.

This mass is then removed from the particles occupying the cell. The deposition for the remaining size classes is then computed, starting with the second largest size class and working down to the smallest. This deposition is computed as follows:

If $0 \leq P_i \leq 0.05$, then

$$Flux_i = \frac{C_i Flux_{i+1}}{C_{i+1} + 1} \quad (21)$$

otherwise,

$$Flux_i = b_i C_i Ws_i P_i \quad (22)$$

The following are typical values for the coefficient b_i for the four size classes previously presented:

- $b_0 = 0.2$
- $b_1 = 0.4$
- $b_2 = 0.6$
- $b_3 = 1.0$

APPLICATION ASPECTS: The first step in an application of SSFATE is to establish an operational area. Locations can range from rivers, lakes, and estuarine systems on a spatial scale of up to tens of kilometers. For each location, the user supplies digital data describing the shoreline and the bathymetry. These data can be digitized from an appropriate map, obtained from digital databases, or produced using an external GIS and imported into the system. The user may have as many locations in the system as computer storage allows and can rapidly change from one location to another by simply loading the appropriate data set into the application.

The embedded GIS allows the user to input, store, manipulate, analyze, and display geographically referenced information. The GIS has been designed to be user friendly, interactive, and fast. However, it does not have the ability for sophisticated mapping or logical set-based calculations. GIS data may not be required by a particular application, but are often helpful in analyzing and interpreting model predictions.

Additional information about geographically referenced data can be obtained through the use of linking procedures. These link files may include charts, graphics, tables, tutorials, bibliographies, text, photographs, or animations. Examples of data that might be stored in the GIS include physical characteristics of the dredged material, details of the placement site location, current meter data sets, and distribution of potentially impacted biota.

A suite of tools is provided within the SSFATE modeling system to import, export, and manipulate environmental data. As an example, time series of scalar or vector data at single or multiple points can be imported. Spatial data can be imported for rectangular or boundary-fitted gridded regions. Through this procedure, data from external models (e.g., hydrodynamic models) or measuring systems (e.g., moored current meters) can be accessed and used as input to the SSFATE modeling system. Tools are also available to import/export data from/to other GISs and existing databases and to create/delete/edit databases in the embedded GIS.

Input data required include the shoreline (or a boundary-fitted numerical grid), bathymetry, ambient currents (either limited field data to generate painted currents or flow fields imported from a numerical hydrodynamic model), dredged material sediment characteristics, model parameters, and output display parameters. In general, spatial information input to SSFATE is handled through the gridding module of the GIS. Time-series data are addressed with environmental data management tools and model parameter options. Input to specify the sediment characteristics, source strengths and locations, and display options is managed through a set of model-specific input forms. Data input is largely based on graphical techniques since they are accurate and fast.

As noted, either a boundary-fitted grid can be imported or a rectangular land-water grid can be generated by SSFATE. For the case of a rectangular grid, the user can apply the suspended sediment fate model in any subdomain of the location area selected. The user identifies the subdomain of interest through its corner points and selects the appropriate grid size. A gridding algorithm is then used to generate a land-water rectangular grid system.

When the rectangular grid is generated, the user may edit the computer-produced grid to better conform to the shoreline or represent openings to restricted passages (e.g., between islands, narrow inlets, etc.). Editing is also useful to add features that are not given on the base map. Once completed, a bathymetric file is automatically generated and stored under a user-selected grid file name. Multiple grid files can be made to define different areas or the same area with various modifications.

SSFATE requires a flow field for execution of the particle tracking computations. As previously discussed, such a flow field can be generated or painted using limited field data (not a mass conservative field) or can be imported as output from a 3-D numerical hydrodynamic model on a boundary-fitted grid.

Model output includes animation of the particles representing each sediment type individually or all of the particles together. A typical snapshot from an animation of suspended sediment particles being transported away from a dredging site is presented in Figure 3. The output display system is designed so that the user can interact with the display window at any time during the trajectory view operation to obtain information on mass balance for a selected size class of particles. Additional model output includes both horizontal and vertical concentration contours of each sediment type or a superposition of all suspended sediment, time-series of suspended sediment concentrations at a particular point, spatial distribution of sediment deposited on the sea bottom, and tabular summaries of how much sediment is in suspension, how much has been deposited, and how much has left the grid. A contouring procedure is available to provide dredged material thickness distributions on the sea bottom and concentrations at user-defined depths in the water column. The user may select the contour intervals and threshold value. The user can interact with the contoured data to obtain pertinent information such as a cross-sectional view along a user-selected transect, the distance to features from the sediment source, and the area covered by material that has been deposited on the bottom.

CONCLUSIONS: A personal computer based modeling system called SSFATE for computing suspended sediment concentrations resulting from dredging operations has been presented and its major components have been described. SSFATE can be used anywhere in the world and provides an integrated and unified system to support data display, model application, and interpretation of results.

SSFATE has been developed to satisfy a specific need for tools to aid in negotiation of environmental windows. Predetermined attributes of such a tool included adaptability to a broad spectrum of dredging project scenarios, low “front end” requirements for input data or supporting hardware, efficient computational algorithms to enable multiple simulations in a short period of time, and effective means of output visualization. The strengths of SSFATE are in its versatility, simplicity, efficiency, and low cost of operation. In tandem with other tools being developed under the auspices of the DOER Program Environmental Windows Focus Area (e.g., FISHFATE, see Ault, Lindeman,

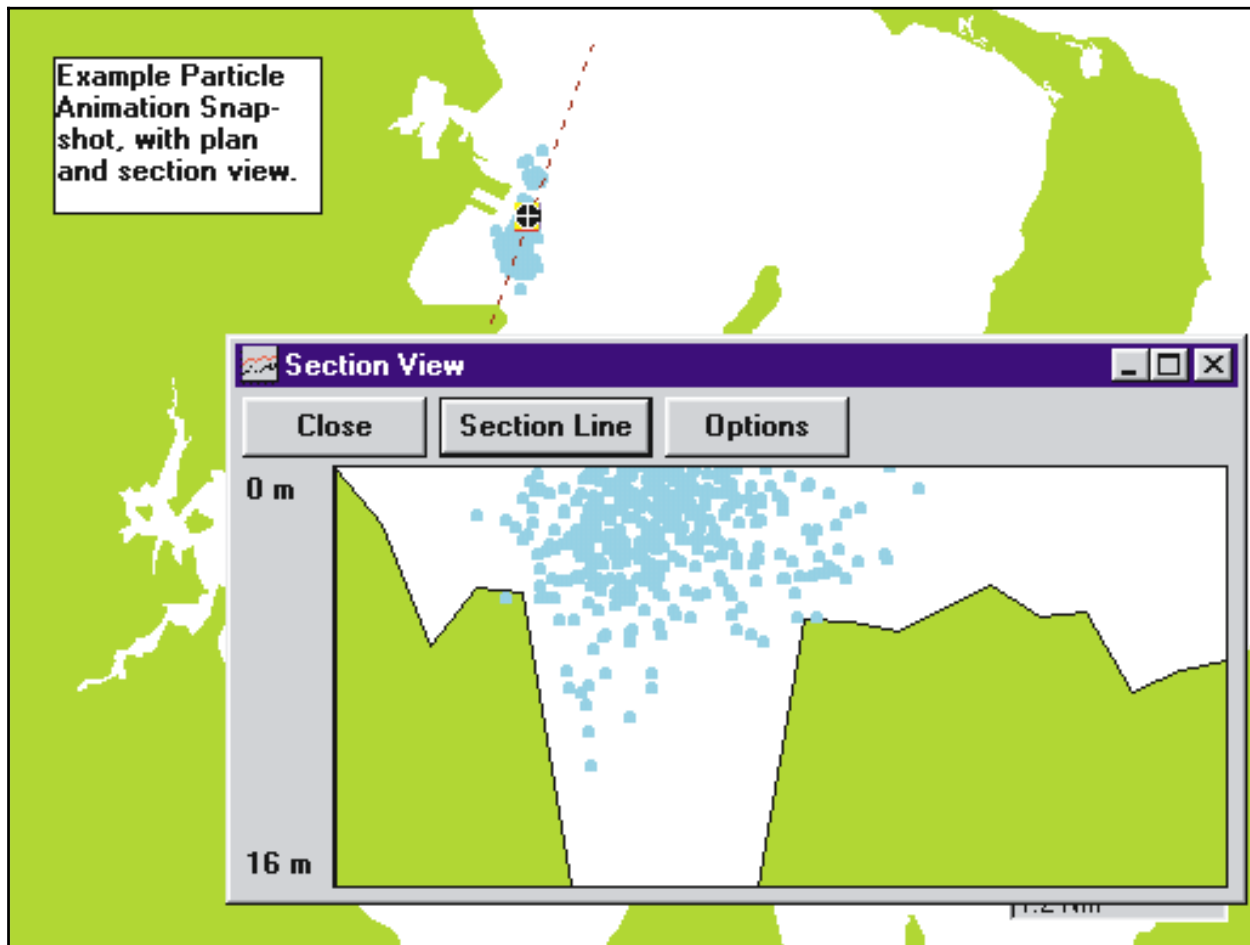

Figure 3. Snapshot from an animation of sediment particles

and Clarke 1998), SSFATE represents a significantly improved capability for dredging project assessments. Dredging project managers and resource agency staff should be able to rapidly explore the effects of model parameters on expectations of impacts, and to optimize their management options, including environmental windows, based on SSFATE results.

POINT OF CONTACT: For additional information, contact Dr. Billy H. Johnson (601-634-3425, johnsob1@wes.army.mil), Mr. Allen M. Teeter (601-634-2820, teetera@wes.army.mil), Dr. Douglas G. Clarke (601-634-3770, clarked@wes.army.mil), or the Program Manager of the Dredging Operations and Environmental Research Program, Dr. Robert M. Engler (601-634-3624, englerr@wes.army.mil). This technical note should be cited as follows:

Johnson, B. H., Andersen, E., Isaji, T., Teeter, A. M., and Clarke, D. G. (2000). "Description of the SSFATE numerical modeling system," *DOER Technical Notes Collection* (ERDC TN-DOER-E10), U.S. Army Engineer Research and Development Center, Vicksburg, MS. www.wes.army.mil/el/dots/doer

REFERENCES

- Ault, J. S., Lindeman, K. C., and Clarke, D. G. (1998). "FISHFATE: Population dynamics models to assess risks of hydraulic entrainment by dredges," DOER Technical Notes Collection (TN DOER-E4), U.S. Army Engineer Research and Development Center, Vicksburg, MS. www.wes.army.mil/el/dots/doer
- Cressman, G. P. (1959). "An operative objective analysis scheme," *Monthly Weather Review* 86, 293-297.
- Johnson, B. H., Kim, K. W., Heath, R. E., Hsieh, B. B., and Butle, H. L. (1991). "Development and verification of a three-dimensional numerical hydrodynamic, salinity, and temperature model of Chesapeake Bay," Technical Report HL-91-7, U.S. Army Engineer Waterways Experiment Station, Vicksburg, MS.
- Johnson, B. H., and Fong, M. T. (1995). "Development and verification of numerical models for predicting the initial fate of dredged material disposed in open water," Technical Report DRP-93-1, U.S. Army Engineer Waterways Experiment Station, Vicksburg, MS.
- Johnson, B. H., and Parchure, T. M. (1999). "Estimating dredging sediment resuspension sources," *DOER Technical Notes Collection* (TN DOER-E6), U.S. Army Engineer Research and Development Center, Vicksburg, MS. www.wes.army.mil/el/dots/doer
- Nakai, O. (1978). "Turbidity generated by dredging projects." *Management of bottom sediments containing toxic substances*, Proceedings of the Third U.S.-Japan Experts' Meeting, Easton, MD, November 1977. EPA-600/3-78-084, S. A. Peterson and K. K. Randolph, ed., Environmental Protection Agency, Office of Research and Development, Corvallis Environmental Research Laboratory, Corvallis, OR, 31-47.
- Reine, K. J., Dickerson, D. D., and Clarke, D. G. (1998). "Environmental windows associated with dredging operations," *DOER Technical Notes Collection* (TN DOER-E2), U.S. Army Engineer Research and Development Center, Vicksburg, MS. www.wes.army.mil/el/dots/doer
- Teeter, A. M. "Cohesive sediment modeling using multiple grain classes; Part I: Settling and deposition" (in review), *Coastal and estuaries fine sediment transport; processes and applications*, papers from INTERCOH 98, South Korea.

NOTE: *The contents of this technical note are not to be used for advertising, publication, or promotional purposes. Citation of trade names does not constitute an official endorsement or approval of the use of such products.*

APPENDIX H

EVALUATION OF PROPOSED LIBERTY PROJECT OCEAN DISPOSAL SITES FOR DREDGED MATERIAL AT FOGGY ISLAND BAY

This appendix was published as part of the Liberty Development and Production Plan (DPP) Draft Environmental Impact Statement (EIS) and was not revised for the Final EIS. The reader is referred to this appendix in the Draft EIS. This appendix is also available on the CD-ROM (MMS 2002-019 CD) and on the Internet (<http://www.mms.gov/alaska/cproject/liberty>).

APPENDIX H

EVALUATION OF PROPOSED LIBERTY PROJECT OCEAN DISPOSAL SITES FOR DREDGED MATERIAL AT FOGGY ISLAND BAY



Alaska District

**DEPARTMENT OF ARMY PERMIT APPLICATION
FILE NUMBER: 6-981109, FOGGY ISLAND BAY 1
SECTION 103, MARINE PROTECTION, RESEARCH AND SANCTUARIES ACT
(COMMONLY REFERED TO AS THE OCEAN DUMPING ACT)**

November 2000

I. Introduction

Section 103 of the Marine Protection, Research and Sanctuaries Act (MPRSA) requires that all transportation of dredged material with the intent to dispose the material in ocean waters be evaluated for potential environmental effects prior to making the disposal. This evaluation assesses the effects of the disposal of dredged material using the criteria set forth by the Environmental Protection Agency (EPA) under the authority of Section 102 (a) of the Act. The purpose of this evaluation is to provide an assessment of the acceptability of the proposed sites for a one-time ocean disposal of dredged material into the marine environment. This evaluation is a modification of the report entitled “Section 103 Marine Protection, Research and Sanctuaries Act, Dredged Material Disposal Site Evaluation, In Support of the Liberty Development Project, US Army Corps of Engineers Permit Application,” prepared by URS Greiner Woodward Clyde, dated November, 1998.

BP Exploration (Alaska) Inc, (BPXA) proposes to develop the Liberty oil field in the Beaufort Sea for production and transport of sales-quality oil to market. The oil field would be developed from a man-made gravel island (Liberty Island) to be constructed on the Federal Outer Continental Shelf (OCS) in Foggy Island Bay. The proposed oil field development includes a subsea pipeline construction from the gravel island to a land-based connection with the Badami Sales Oil Pipeline. The pipeline trench would be constructed during the winter months and transportation of dredged material would occur on ice roads. During pipeline trench construction, the majority of dredged material would be used as trench backfilled material. However, up to 110,000 cubic yards (yd³) (76,500 cubic meters [m³]) of excess dredged material from the nearshore trench could be disposed of in two locations in Foggy Island Bay.

The need for ocean disposal of dredged material is a result of several factors: displacement of volume by the pipelines, the addition of gravel backfill (67,000 yd³) for pipeline bedding, and material expansion due to the natural swell of dredged materials placed back into the trench. Additional information on why ocean disposal is a preferred disposal method is provided in DEIS, Section I.H.5.d. Ocean disposal of up to 110,000 yd³ of dredged material could be required.

II. Proposed Action

2.1 PROJECT OVERVIEW

The following provides a summary description of proposed Liberty Project (Alternative 1) with emphasis on offshore pipeline construction and disposal of excess dredged material. A detailed project description is provided within the Department of Army Public Notice for Permit Application #6-981109, Foggy Island Bay 1; and the *Draft Environmental Impact Statement for the Liberty Development Project*, prepared by US Department of Interior, Minerals Management Service. The man-made Liberty Island would be located in Federal Outer Continental Shelf waters at Foggy Island Bay in approximately 22 feet of water. The proposed Liberty Development Project would consist of an offshore drilling/production facility capable of processing and transporting 65,000 barrels of oil per day through a buried offshore (seafloor) pipeline and above ground onshore pipeline. The offshore segment is a nearly straight route from the Liberty Production Island to a landfall located about 6.1 miles south-southwest of the island. The 1.5 - mile onshore segment is nearly a straight route to the existing Badami Sales Oil Pipeline. A 12-inch Sales Oil Pipeline would transport Sales quality crude oil to the Badami Sales Oil Pipeline. A 6-inch Products Pipeline would import fuel gas for start-up activities to Liberty from the Badami Products Pipeline prior to first Liberty production, and then export product to the Badami Pipeline after start-up.

Figure 1: Dredged Material Site Zones 1 & 2 for Proposed Island/Pipeline Alternative

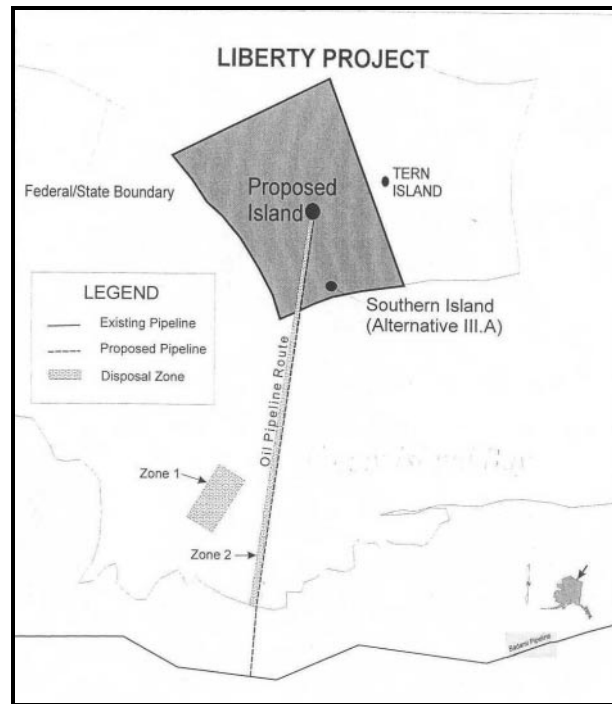

Table 1: Disposal Site Zones Dimensions and Capacities for Proposed Island/Pipeline Alternative

OCEAN DUMPING OF DREDGED MATERIALS (EXCESS OFFSHORE PIPELINE CONSTRUCTION SPOILS)	DISPOSAL SITE FOOTPRINT LIMITS (FEET)	VOLUME (CUBIC YARDS)	AREA (ACRES)
Disposal Zone 1 (limits)	2,000 x 5,000	Up to 100,000	230
Disposal Zone 2 (limits)	32,300 x 200	Up to 10,000	150

2.2 PROJECT ALTERNATIVES

Section II. of the EIS provides a detailed description of alternatives under consideration. Three of these alternatives: Southern Island/Eastern Pipeline Route, Tern Island/Tern Pipeline Route, and Bury the Pipeline Deeper would effect the § 103 evaluation. The alternative island locations and the pipeline routes would alter the disposal locations with minor changes in disposal quantities while burying the pipeline deeper could significantly increase the quantities of dredged material for open water disposal. The following provides a brief summary of these alternatives that are carried forward for consideration in the EIS. The basic concepts of pipeline construction and disposal plans are similar between the alternatives. With the exception of the distance from important living resources, the evaluation presented herein is applicable to the alternatives.

The southern island would be in – 18 feet MLLW, 4.2 miles from shore approximately 1.5 miles south-southeast of the proposed Liberty Island. The overall pipeline for the Eastern Pipeline route is 7.3 miles with 4.2 miles offshore. Approximately 499,025 yd³ of material would be excavated. Excess trench material would be stockpiled in Zone 3 for ocean disposal and temporary stored in Zone 4 (contingency disposal). Zone 3 is located on the west side of the pipeline right-of-way on grounded sea ice outside the 5-foot isobath. Maximum dimensions is the same as for Alternative 1, Zone 1 disposal site with the same grooming and height restrictions. The maximum quantity for disposal is also the same at 100,000 yd³ with the approximately 27 % of Zone 3 (62 acres) being utilized for actual disposal). However, approximately 69 percent of the dredged material for the southern route would be composed of fine grain material compared to 65 percent estimated for the proposed pipeline route. Disposal site, Zone 4, extends from the island to shore. It is approximately 4.2 miles in length, 200 feet wide and located west of the pipeline. Approximately 0.1 mile is seaward of the 3-mile limit. Zone 4 is

designed as temporary on-ice storage. The maximum quantity of excess trench material stockpiled of left for disposal on the site at any one time would not exceed 10,000 yd³.

Figure 2: Dredged Material Site Zones 3 & 4 for Southern Island/Eastern Pipeline Alternative

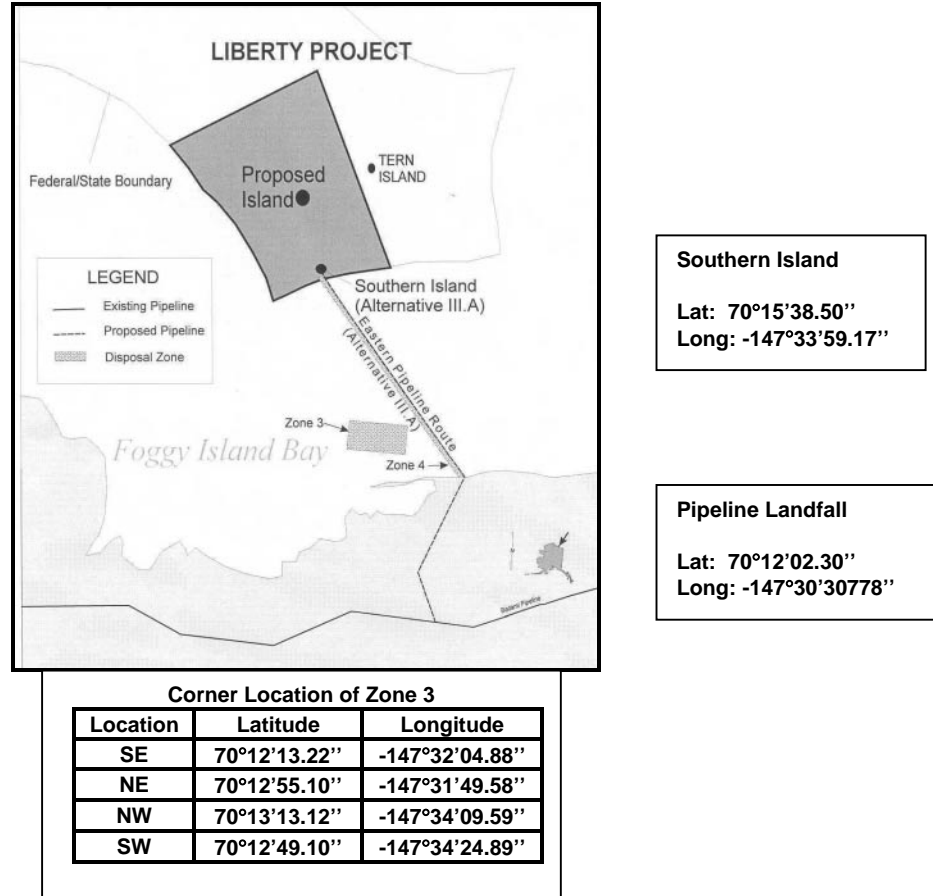

Table 2: Disposal Site Zones Dimensions and Capacities for Southern Island/Eastern Pipeline Alternative

OCEAN DUMPING OF DREDGED MATERIALS (EXCESS OFFSHORE PIPELINE CONSTRUCTION SPOILS)	DISPOSAL SITE FOOTPRINT LIMITS (FEET)	VOLUME (CUBIC YARDS)	AREA (ACRES)
Disposal Zone 3 (limits)	2,000 x 5,000	Up to 100,00	230
Disposal Zone 4 (limits)	22,175 x 200	Up to 10,000	102

The Tern Island and pipeline alternative is located within 23 feet of water, 5.5 miles offshore in Foggy Island Bay. Tern Island is ~1.5 miles east of the proposed Liberty Island location. The overall pipeline length is 8.6 miles with the offshore portion approximately 5.5 miles. Approximately 652,800 yd³ of material would be required for trench construction with variable top trench width between 61-132 feet. Zone 3 is identical to Zone 3 for the southern island alternative in terms of location, size, material restrictions, etc. Disposal site, Zone 5, is comparable to Zone 2 (Alternative 1) and Zone 4 (southern island) with same limitation of 10,000 yd³ stockpiled at any one time with height restriction of 1-foot over depths less than 16 feet and 2 feet in areas greater than 16 feet in depth.

Figure 3: Dredged Material Site Zones 3 & 5 for Tern Island/Pipeline Alternative

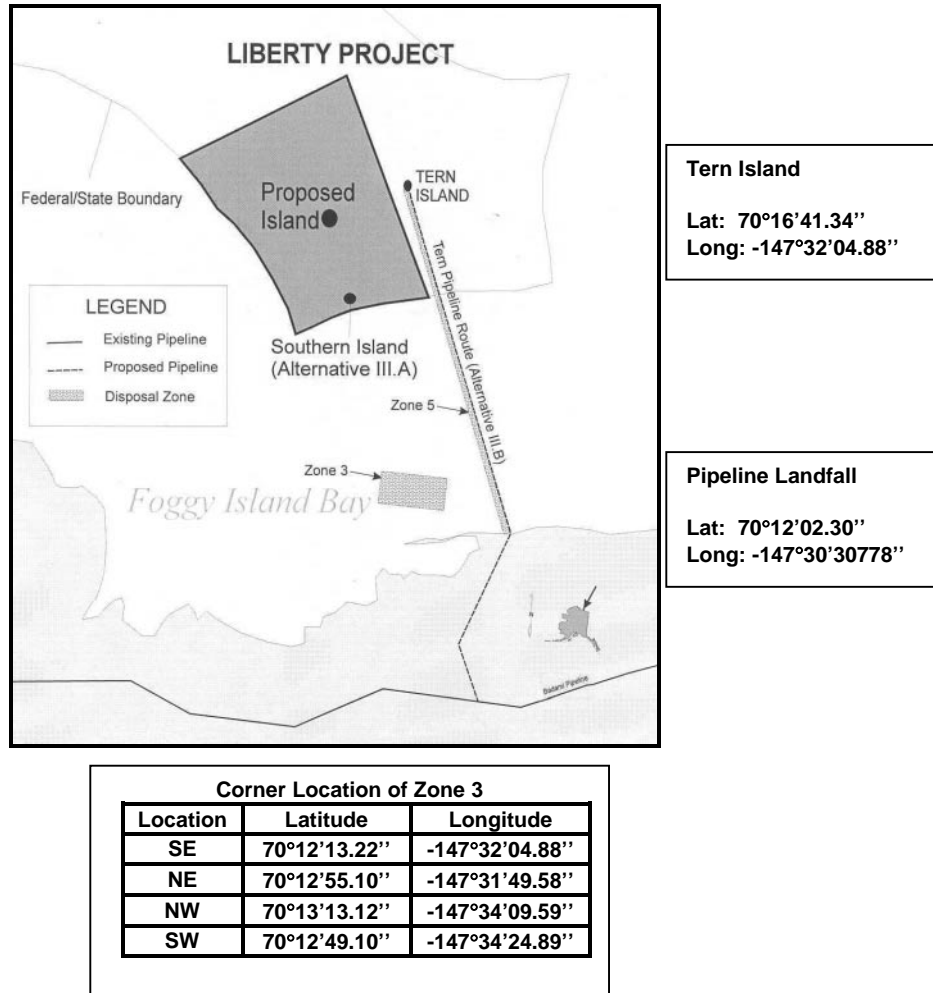

Table 3: Disposal Site Zones Dimensions and Capacities for Tern Island/Pipeline Alternative

OCEAN DUMPING OF DREDGED MATERIALS (EXCESS OFFSHORE PIPELINE CONSTRUCTION SPOILS)	DISPOSAL SITE FOOTPRINT LIMITS (FEET)	VOLUME (CUBIC YARDS)	AREA (ACRES)
Disposal Zone 3 (limits)	2,000 x 5,000	Up to 100,000	230
Disposal Zone 5 (limits)	29,100 x 200	Up to 10,000	134

2.3 PIPELINE CONSTRUCTION

The proposed pipeline system would be constructed during the winter within a temporary construction right-of-way (1500 feet wide offshore; 250 feet wide onshore). An ice road and/or thickened sea ice would be built within the construction right-of-way to support pipeline construction. Work would be done from the thickened (~8-foot thick) ice using conventional excavation and other construction equipment. Offshore, the pipelines would be buried in a common trench. Construction of the trench would progress from shallower water to deeper water. The trench would be excavated/dredged, pipelines laid in the trench, and the dredged material utilized as trench backfill. The proposed depth of cover over the 12-inch pipeline is a minimum of seven feet and a maximum of 12 feet depending on bottom sediments. Cover is defined as the distance from the original seabed to the top of pipe. Of the estimated 724,000 yd³ of material that would be excavated, about 657,000 yd³ would be used as backfill material within the pipeline trench.

The construction sequence of the trenching and pipe laying operations is:

1. Thicken sea ice along route. Increasing ice thickness to 8 feet is required to support the excavation equipment. (Note: where bottomfast ice is present, thickening of the sea ice is not anticipated).
2. Cut a slot in the ice. The ice would be cut into blocks and removed by conventional excavation equipment or, where the ice is grounded, by only using conventional excavation equipment. The blocks would be transported from the work site to prevent excessive deflection of the ice in the work area as needed.
3. Excavate the trench using conventional excavation equipment, including a hydraulic (suction pump) dredge attachment on a backhoe. Excavated material would be backfilled over the pipeline in the trench, or stockpiled in one of two designated areas.

Once construction is underway, just-excavated trench spoils would be transported and placed as backfill over recently-laid pipeline segments in a continuous process. However, during initial stages of construction, spoils excavated from the trench would be temporarily stockpiled. As much as possible the dredged material/spoils would later be removed from the stockpile and transported to the trench and used as backfill. For safety and flexibility two stockpile locations have been identified (Zone 1 and Zone 2), and for alternatives (Zones 3 and 4) as shown in Figure 2-1.

Backhoes would be used as the primary equipment for trench excavation (mechanical dredging). It is estimated that seven backhoes would operate simultaneously along the construction spread. Backhoes would excavate material to the required depth. The backhoe bucket capacities range from 2 yd³ to 4 yd³, and can repeat excavation about once a minute. A front-end loader would operate in tandem with each backhoe for loading spoil and transporting it to be backfilled in a nearby trench section or to be stockpiled.

Hydraulic dredging (agitator pump) would be used in conjunction with the backhoe bucket, as needed to achieve trench bottom smoothness criteria for pipe integrity and in cases where slumping of trench side walls requires hydraulic cleanout. This technique could be used anywhere along the trench but its use would be limited to a cleanout method not to exceed 10% of total dredged quantities. The agitator pump, to be used as a clean-out tool, is a device that is attached to the backhoe. This enables the backhoe to make a final pass, removing a layer of material to within the specified engineering elevation tolerance, since the backhoe bucket could leave scallops and gouges from the bucket teeth in the trench bottom. The clean-out tool would create a smooth, uniform trench bottom on which to lay the pipelines. As the agitator pump is moved down the trench, it would pick up and transport material with the least amount of water possible.

The agitator pump is a relatively small cutter-suction pump/dredge. It would be mounted at the end of the backhoe arm or suspended from a platform on top of the ice to control vertical and horizontal movement. The clean-out tool is powered hydraulically from the surface by a 100 horsepower electric pump. A rubberized discharge hose (up to 10-inch diameter) is connected to the tool and remains under water trailing behind the tool. The amount of material moved would depend on the soil/substrate type encountered. The discharge hose would trail approximately 200 to 300 ft behind the tool. This discharge nozzle would be tethered as to not contact the installed pipe and directed back into, or immediately adjacent to the trench. It is estimated that the dredged material would be 60 - 70 percent solids and 30 - 40 percent liquid. Excavation rates using the dredge are estimated at 150 yd³ per hour.

Select backfill (gravel) would be required in the trench to assure vertical pipeline stability. This would be achieved by placing gravel-filled geotextile bags over the top of the pipeline in the trench. After the pipe is laid in the trench, the bags would be placed in regular intervals axially across the pipe so that approximately 50 percent of the pipeline route is covered (from the island to the toe of the bluff at the shoreline). The bags would then be buried within the remaining backfill material.

There are threshold conditions, though, under which some excavated material cannot be placed back into the trench and would require disposal. One case is where the quantity of excess spoil is greater than can be accommodated over the trench without over-mounding. The amount of mounding over the pipeline is not a factor affecting pipeline integrity, but is of environmental concern. In the area of grounded ice construction (to about the 8-foot isobath), the cap of the backfill would be close to the original seafloor, and would not be greater than 1-foot higher than the original seafloor. A criterion of 2-foot mounding (above original seafloor) has been set for waters outside to 8-foot isobath.

2.4 DISPOSAL PLAN

Two locations are designated for temporary storage (on the ice surface) and as disposal sites of excess dredged materials.

Zone 1 is located on the west side of the pipeline right-of-way on grounded sea ice outside the 5-foot isobath. Maximum dimensions of the site would be 5,000 feet by 2,000 feet (230 acres). Zone 1 would serve as the primary temporary storage location of all materials excavated during trenching operations that cannot be directly transported for backfill along the pipeline. For dredged material/spoils that cannot be used as backfill, Zone 1 would serve as the designated disposal site.

Dredged material placed in Zone 1 would be groomed to a height not to exceed one foot to minimize the potential for mounding on the sea floor. The size of the site was selected to provide operational flexibility, and the entire site would not be used for disposal. Material would be stacked on portions of the site over deeper water first, then over shallower water. The maximum quantity of spoils stockpiled or left for disposal on this site at any one time is would not exceed 100,000 yd³. Assuming that this maximum quantity of up to 100,000 yd³ of spoils would be disposed of on the site in one foot high stacks, about 27 percent of Zone 1 (about 62 acres) would be used for actual disposal.

Selection of the Zone 1 site was based on results of the applicant's Boulder Patch surveys and ongoing agency coordination and guidance. A major criterion used in selecting the site was avoidance of potential impacts to the Boulder Patch habitats, by not placing the disposal site directly over known Boulder Patch, and maintaining distance from known Boulder Patch to minimize effects from the disposal activity, given consideration of normal oceanographic conditions. Other important criteria include maintaining a safe distance from active pipelaying operations, reasonable hauling distance, water depth greater than five feet, and local fate and transport mechanisms.

Zone 2 is a 200-foot wide section along the west side of the pipeline trench from the island to shore. Zone 2A is that segment in water depths less than approximately 16 feet; Zone 2B is that segment located on floating ice, in water depths greater than 16 feet. About 24,200 feet of Zone 2 is within the Territorial Seas (3-mile limit) while 8,000 feet is seaward of the 3-mile limit.

Zone 2 is a temporary storage area (on the ice) and contingent disposal location for dredged materials in the event weather or ice conditions dictate the abandonment of operations prior to completion. The maximum quantity of spoils stockpiled or left for disposal on this site at any one time would not exceed 10,000 yd³. Spoils in Zone 2A would normally be stacked or groomed to maintain an approximate depth of less than one foot. Spoils placed in Zone 2B would be stacked or groomed to a height not to exceed 2 feet. It is the applicant's intent to clear Zone 2 of all excess dredged material/spoils by spring breakup. This would be accomplished by scraping the ice with heavy equipment, leaving at most, a veneer of dirty ice (a very small amount of sediment remaining in the frozen matrix).

Regulation of dredged material disposal within waters of the United States and ocean waters is a shared responsibility of the US Environmental Protection Agency (EPA) and the US Army Corps of Engineers (USACE). The primary Federal environmental statute governing the disposal of dredged material in ocean waters and the transportation of dredged material to the ocean for the purpose of disposal are Sections 102 and 103 of the Marine Protection, Research and Sanctuaries Act (MPRSA), also called the Ocean Dumping Act. The primary Federal environmental statute governing the discharge of dredged or fill material into waters of the United States (inland of and including the Territorial Sea) is the Federal Water Pollution Control Act, also

called the Clean Water Act (CWA). The geographical jurisdiction of the MPRSA and CWA overlap within the Territorial Sea. The precedence of MPRSA or the CWA in the area of the Territorial Sea is defined in 40 CFR 230.2(b) and 33 CFR 336.0(b). Material dredged from navigable waters of the United States (e.g. excess dredged material resulting from pipeline trench excavation) and disposed of in the Territorial Sea is evaluated under MPRSA. Dredged material discharged as fill material (e.g. excavated pipeline trench material which is utilized as backfill material) and placed within the Territorial Sea is evaluated under the CWA.

For regulatory purposes the following definitions are used: *Ocean Waters* means those waters of the open sea lying seaward of the base from which the Territorial Sea is measured, as provided for in the Conventions on the Territorial Sea and Contiguous Zone (15 UST 1606: TIAS 5639). *Dredged Material* means any material excavated or dredged from navigable waters of the United States. *Transportation* refers to the conveyance and related handling of dredged material by vessel or other vehicle. *Discharge of Fill Material* means the addition of fill material into waters of the United States and includes without limitation, the placement of fill that is necessary for the construction of any structure in a water of the United States. *Territorial Sea* (as used in defining limits of CWA jurisdiction) means the limit of jurisdiction in the territorial sea that is measured seaward from the baseline in a seaward direction a distance of three nautical miles. Where the baseline is generally defined as: where the shore directly contacts the open sea, the line on the shore reached by the ordinary low tides comprise the baseline from which the distance of three geographic miles is measured.

The authority of the Secretary of Army to prevent obstructions to navigation in navigable waters of the United States was extended to artificial islands, installations, and other devices located on the seabed, to the seaward limit of the outer continental shelf, by section 4(f) of the Outer Continental Shelf Lands Act of 1953 as amended [43 U.S.C. 1333(e)].

Application and authorization for the transportation of dredged material by vessel or other vehicle for purpose of dumping in ocean waters (Section 103 of the MPRSA) are evaluated by the USACE to determine whether the proposed dumping will unreasonably degrade or endanger human health, welfare, amenities, or the marine environment, ecological systems or economic potentials. The evaluation requires application of the criteria (40 CFR Parts 220-229) established by EPA pursuant to section 102 of the MPRSA. The USACE is required to submit, in writing, to the EPA, Regional Administrator, results of the evaluation, which requires evaluation based on 11 specific criteria (40 CFR 228.6) and 5 general criteria (40 CFR 228.5). EPA then makes an independent evaluation of the proposed dumping in accordance with the same criteria and informs the USACE, in writing, of the determination on whether or not the proposed dumping would comply with the criteria (40 CFR 225.2[c-e]). The following (sections 3.1 to 3.11, below) evaluates the proposed disposal sites with 11 specific criteria and the potential environmental impact(s) associated with disposal of dredged material based on these criteria. This evaluation is based on information supplied by the applicant (BPXA) in the report entitled "Section 103 Marine Protection, Research and Sanctuaries Act, Dredged Material Disposal Site Evaluation, In Support of the Liberty Development Project, US Army Corps of Engineers Permit Application," prepared by URS Greiner Woodward Clyde, dated November, 1998.

3.1 GEOGRAPHIC LOCATION

Zone 1 is located in the southwest corner of Foggy Island Bay in waters between 5 ft (1.5m) and 7 ft (2.1 m) deep. The shoreline is approximately 1.3 miles (2 km) toward and south and west. Zones 2A and 2B are 200-ft wide sections within pipeline construction right-of-way. Zone 2A extends along the from shore seaward 3.4 miles (5,500 m) to the 16-ft (4.9 m) isobath, and Zone 2B starts at the 16-ft (4.9 m) isobath and extends to Liberty Island. The corners of each temporary stockpile and disposal area are provided below in latitude/longitude, horizontal datum: NAD27:

	Latitude (degrees north)	Longitude (degrees west)
Zone 1	70° 14' 16.65"	147° 40' 24.76"
	70° 14' 02.82"	147° 39' 43.41"
	70° 13' 27.83"	147° 41' 25.49"
	70° 13' 41.65"	147° 42' 06.85"
Zone 2A	70° 12' 15.08"	147° 41' 34.63"

	70° 12' 16.36"	147° 41' 40.85"
	70° 14' 46.37"	147° 37' 03.21"
	70° 14' 47.74"	147° 37' 09.28"
Zone 2B	70° 14' 46.37"	147° 37' 03.21"
	70° 14' 47.74"	147° 37' 09.28"
	70° 16' 42.49"	147° 33' 42.55"
	70° 16' 41.20"	147° 33' 36.32"

3.2 DISTANCE FROM IMPORTANT LIVING RESOURCES

The biological base condition for the project area is described in Section VI. *Detailed Description of the Effected Environment*, in the *EIS for the Liberty Development Project*, prepared by USDOJ-MMS, January 2001. Species expected to occur in the disposal area are listed in Table 1 and are discussed below. As required by 40 CFR 228.6, this discussion focuses on the length of time that biological organisms could be expected to be in the area and the potential biological processes that could be affected (e.g., feeding, migration, or breeding).

Benthic Organisms

Benthic organisms consist of both infaunal and epifaunal invertebrates. Infaunal invertebrates are organisms which live in the sediment. Due to the unstable environment, they occur in low densities in nearshore areas. Bottomfast ice tends to eliminate the infaunal populations each winter. The areas are then recolonized by opportunistic species during the next open-water season (Broad 1977, Broad et al. 1978, Feder et al. 1976, Grider et al. 1977 and 1978, Chin et al. 1979). The colonizers consist primarily of juvenile annelid worms and clams. In deeper waters (depths greater than 10 ft [3 m]) polychaete worms are the dominant species along with two clam species and several crustacean species.

Epibenthos is defined as benthic invertebrates that reside on or near the surface of the substrate. In general, epibenthic species diversity and abundance increase as water depth increases. The proportion of longer-lived sessile or sedentary species also increases as compared to the more motile and opportunistic species found closer to shore in more shallow waters. The presence of the shore-fast ice in the nearshore zone (waters <6.5 ft [2 m] deep) prevents most species from overwintering in this zone. Therefore, the nearshore benthic community is dominated by motile, opportunistic species that can recolonize the area after the ice melts in the spring. The most abundant groups in this zone include epibenthic amphipods, mysids, and isopods.

The Zone 1 disposal site is located in water depths less than 10 ft (3 m). Therefore benthic organisms cannot survive the winter at this site, and they are not expected to recolonize the area until bottomfast ice is gone. Thus, very few of these organisms would be affected by sedimentation from trench spoil during breakup at Zone 1. Water depths at Zone 2B range from about 16 to 20 ft (4.9 to 6 m). Benthic organisms are more diverse and abundant in deeper waters, but effects of sedimentation from the Zone 2B stockpile are expected to be minimal and transitory.

Marine and Anadromous Fish

The nearshore zone serves as a corridor for fishes that are intolerant of more marine conditions and as feeding habitat for both anadromous and marine fishes (Craig 1984). Arctic and least cisco, Arctic cod, Dolly Varden and fourhorn sculpin comprise 90 percent of the fish caught in nearshore Beaufort Sea areas. In addition to Dolly Varden (age 5 and older), anadromous fishes in the nearshore zone include Arctic cisco (all ages), and adult and subadult least cisco and broad whitefish. The anadromous fish enter the nearshore waters at the start of breakup (early June) to feed during the summer. During open-water periods, anadromous fish are concentrated in the nearshore zone, particularly within 350 ft (107 m) of the shoreline. The fish then return to low salinity water in deep channels of rivers and deltas to overwinter. The Sagavanirktok River Delta provides important fish habitat for overwintering, and in some cases spawning (Fechhelm et al. 1996).

Marine species found in and adjacent to nearshore waters include primarily Arctic cod, saffron cod, fourhorn sculpin, Arctic flounder, and rainbow smelt (LGL et al. 1998). Arctic cod are the most dominant species in the

Arctic Ocean and are the most abundant fish collected in the Prudhoe Bay region. Snailfish, another widely distributed taxon in the Beaufort and Chukchi seas, are also taken in moderate numbers in the Prudhoe Bay area and are likely found in the Liberty Development Project area (LGL et al. 1998).

Although many of these fish species may be found within the project area during the ice-free period, their mobility increases the likelihood that they would be able to leave the disposal area if dispersing sediments from melting spoil piles cause localized increased turbidity. In addition, fish such as Arctic cod, Arctic char, Arctic cisco, least cisco, broad whitefish, humpback whitefish, and rainbow smelt are able to tolerate waters exhibiting high turbidity values (up to 146 NTU [Craig 1984]). The dynamic nature of ice movement, river overflow, and sediment disturbance during breakup is likely to overshadow any increase in turbidity resulting from spoil disposal.

Boulder Patch Community

Areas in Stefansson Sound with dense rock cover (more than 25 percent rock cover) are known to contain rich epilithic flora and fauna, including extensive kelp beds (Reimnitz and Toimil 1976). Isolated patches of marine life also occur in areas where the rocks are more widely scattered (10 to 25 percent rock cover). The areas of Stefansson Sound containing rocky substrate have been charted and are designated the "Boulder Patch." Although boulders up to 2 meters across and 1 meter high are sometimes encountered, most of the rock cover occurs in the pebble to cobble size range (2 to 256 mm on the modified Wentworth Scale). Stefansson Sound provides the necessary combination of rocky substrate, depth sufficient to allow a 12- to 14-ft (3.5- to 4.5-m) thick layer of free water under the ice during winter, and the presence of offshore shoals and barrier islands that protect the area from extensive gouging and reworking of the bottom by ice (Dunton and Schonberg 1981).

The boulders and attached dominant kelp species, *Laminaria solidungula*, provide habitat for many invertebrate species. Sponges and cnidarians, including the soft coral *Gersemia rubiformis*, are the most conspicuous invertebrates. Approximately 98 percent of the carbon produced annually in the Boulder Patch is derived from kelp and phytoplankton. *Laminaria* is estimated to contribute 50 to 56 percent of the annual production depending on whether the plants are beneath clear or turbid ice (Dunton 1984). Photosynthesis is limited to a short period annually when light is available and ice cover has receded. *Laminaria* then stores food reserves until winter and early spring when nutrients are available. As a result, blade elongation (growth) is greatest during periods of darkness and turbid ice cover (Dunton and Schell 1986). The only herbivore that consumes kelp in the Boulder Patch is the chiton, *Amicula vestita* (Dunton 1984).

Increased turbidity could adversely impact kelp by decreasing light available for photosynthesis (Toimil and Dunton 1984). However, any ice movement should place the spoil piles well landward of known Boulder Patch areas. See attachment to Appendix G, *Liberty Development: Construction Effects on the Boulder Patch Kelp Production*. (May 1999) for additional information.

Marine and Terrestrial Mammals

Eight species of marine mammals, including two baleen whales (bowhead and gray whales), one toothed whale (beluga whale), three pinnipeds (ringed seal, bearded seal, and spotted seal) and the polar bear, inhabit or visit the Alaskan Beaufort Sea regularly.

Bowhead and beluga whales migrate through the Alaskan Beaufort Sea. Gray whales, which sometimes summer in Alaskan Beaufort Sea water near Point Barrow, are unlikely to be present in the area of concern. The Liberty Development Project is located inside the barrier islands and south of the usual migration corridor used by bowhead and beluga whales. The bowhead whale is currently listed as an endangered species (see Threatened and Endangered Species below). The Beaufort Sea stock of beluga whales is not in decline or otherwise threatened by present levels of human activities and is not classified as a strategic stock (Small and DeMaster 1995). In 1994, the gray whale was removed from the List of Endangered and Threatened Wildlife.

"Ice seals" (ringed, bearded, and spotted seals) are usually observed in open-water areas during summer and early autumn, although spotted seals also haulout on beaches and offshore islands and bars, and can be found in bays, lagoons, and estuaries. Ringed seals are found in areas of landfast ice during winter, while bearded seals occupy the active ice zone during winter and spring (LGL et al. 1998). A few ringed and bearded seals were seen near the project area during the MMS aerial surveys. Spotted seals were not identified during aerial

surveys (Frost et al. 1997). Boat-based marine mammal monitoring was conducted from July 25 to September 18, 1996 in an area near and to the west of the proposed Liberty Development Project. The survey documented the presence of all three seals, with 92 percent ringed seals, 7 percent bearded seals, and 1 percent spotted seals (Harris et al. 1997). Site-specific applicant-sponsored aerial surveys for ringed seals were initiated around Liberty in May/June 1997. These surveys, over landfast ice, found ringed seals widely distributed throughout the Liberty area, but no other seal species were encountered (LGL et al. 1998).

Polar bears are normally associated with pack ice, well offshore of the development area. Denning females, females with cubs, and subadult males may occasionally come ashore; females with young cubs hunt in fast-ice areas. Most female polar bears den on pack ice, but five den sites on land have been identified within the development area (LGL et al. 1998). Polar bears may also den on barrier islands near the development area. They may be near the Liberty Development Project at any time, although the animals are most likely to occur near the coast in the fall. Polar bears also may be attracted to the development area by whale carcasses disposed of on Cross Island by Native subsistence hunters. In November 1996, at least 28 polar bears were attracted to the island by a whale carcass (LGL et al. 1998).

Disposal of dredged material at proposed disposal sites is not expected to affect marine mammals occasionally encountered in the project area. Whales are not expected to transit waters in the vicinity. The small numbers of seals and polar bears that may be present during and after breakup are not likely to be adversely impacted by the spoil piles.

Birds

An estimated 10 million individual birds, representing over 120 species, use the Beaufort Sea area from Point Barrow, Alaska to Victoria Island, NWT, Canada (Johnson and Herter 1989). Descriptions of marine and coastal birds in the Alaskan Beaufort Sea area have been presented in the Liberty Development Environmental Report (LGL et al. 1998) and the FEISs for Lease Sales 97, 109, 124 and 144 (MMS 1987a, 1987b, 1990, 1996, respectively). Nearly all species are migratory, occurring in the Arctic from May through September. The most abundant marine and coastal birds in the Foggy Island Bay and the Liberty Development Project areas include Oldsquaw, Glaucous Gull, Common Eider, Snow Goose, Red Phalaropes, and Red-necked Phalaropes, Semipalmated Sandpiper, Dunlin, and Stilt Sandpiper. The Liberty Development Environmental Report (LGL et al. 1998) lists species likely to occur in the study area.

Although all of these bird species may migrate through, rest, and/or feed in the vicinity of the proposed disposal zones, the disposed material is not expected to adversely impact habitat areas used by these birds.

Threatened and Endangered Species

The Western Arctic (Bering-Chukchi-Beaufort) stock of bowhead whales (*Balaena mysticetus*) is currently listed as endangered under the Endangered Species Act and is classified as a strategic stock by the National Marine Fisheries Service (NMFS) (Small and DeMaster 1995). The bowhead population, currently estimated at 8,000, is increasing by 2.3 percent per year (Small and DeMaster 1995).

Western Arctic bowheads winter in the central and western Bering Sea, summer in the Canadian Beaufort Sea, and migrate around Alaska in spring and autumn (Moore and Reeves 1993). Spring migration through the western Beaufort Sea occurs through offshore ice leads, generally from mid-April to mid-June. The migration corridor is located very far offshore of the Liberty Development area; however, a few bowheads have been observed in lagoon entrances and shoreward of the barrier islands (LGL et al. 1998). Autumn migration of bowheads into Alaskan waters occurs primarily during September and October. A few bowheads can be found offshore of the development area in late August during some years, but the main migration period begins in early to mid-September and ends by late October. During fall migration, most of the bowheads sighted migrate in water ranging from 65- to 165-ft (20 to 50 m) deep. These migration corridors are all outside of the development area. When passing the development area, most bowheads are in depths > 65 ft (20 m), but a few occur closer to shore in some years.

In addition to the bowhead whale, there are two threatened or endangered bird species which may occur near the Liberty Development Project area. The Spectacled Eider (*Somateria fischeri*) is the only endangered or threatened bird likely to occur regularly in the study area. The Alaska-breeding population of the Steller's Eider

(*Polysticta stelleri*) was listed as threatened on July 11, 1997 by the U.S. Fish and Wildlife Service (62 *Federal Register* 31748). This species may occur in very low numbers in the Prudhoe Bay area and occasionally in the study area. The Arctic Peregrine Falcon (*Falco peregrinus tundrius*) had been listed as threatened, but the U.S. Fish and Wildlife Service removed it from the list on 5 October 1994 (59 *Federal Register* 50796). The Eskimo curlew, although historically present, is now considered to be extirpated from the area.

The Spectacled Eider and the Steller's Eider would not likely be affected since they are not expected to forage in the discharge area. Therefore, no direct effects of the discharge would occur. The endangered bowhead whale is also an unlikely visitor to the area inside of the barrier islands, and these mammals do not feed in the shallow waters surrounding Liberty Island.

3.3 DISTANCE FROM BEACHES

The landward side of Zone 1 is approximately 1.3 miles (2 km) from the mainland shore, and the southern end of Zone 2 is at the shoreline. The Foggy Island Bay shoreline is composed typically of erosional, wave-cut tundra bluffs, small sandy beaches, river deltas, and spits. While a small quantity of spoil could wash ashore, the shorelines are not expected to be impacted by the spoils. Barrier islands located over 4 miles (6.5 km) north of the excavation activity are not expected to be impacted.

3.4 TYPES AND QUANTITIES OF MATERIAL TO BE DISPOSED

Geophysical Survey Results

High resolution geophysical data was collected in the summer of 1997 to identify geological hazards and man-made materials that would affect or alter the design of the proposed Liberty Development (Watson Company 1998). This was a comprehensive survey, collecting geophysical data from high-resolution multi-channel seismic systems, digital side scan sonar, and a sub-bottom profiler. This survey did not identify any man-made structures or observable effects from human-use activities.

Watson described the seafloor as gently undulating, although a northwest-southeast ridge with 3 to 6 ft (1 to 2 m) of relief was delineated west of the proposed gravel island. Interpretations of side-scan sonar records indicate seafloor sediments with greater than 25 percent boulders and cobbles are situated west and northwest of the proposed gravel island. Watson noted that the seafloor areas, characterized by boulders and cobbles, are considered to be lag deposits of Pleistocene origin and were formed by the erosion of the Flaxman marine units of the Gubik Formation. These lag deposits are exposed on the seafloor where Holocene (recent) sediments are absent (Watson Company 1998).

Analysis of geophysical records determined that approximately 75 percent of the 1997 survey area consists of Holocene fine-grained materials characterized by low reflectivity with sparse or no apparent boulders (Watson Company 1998). Watson states that the Holocene sediments are relatively thin, less than 8.5 ft (2.6 m), with distributions characterized as small patchy accumulations of soft mud. While the deposits are considered to be marine sediments, the source may be fine-grained silts and clays discharged from the Sagavanirktok River (Watson Company 1998).

Physical Properties of the Dredged Material

Duane Miller & Associates conducted geotechnical exploration surveys in 1997 and 1998 along possible pipeline alignments, including the selected route. The following narrative summarizes the subsurface conditions delineated during the 1998 survey, which included 18 borings along the pipeline route.

The seafloor sediments at the island location can be divided into three primary horizons: the upper Holocene non-plastic silt; the intermediate Pleistocene clayey silt; and the underlying granular sand and gravel (Duane Miller & Associates 1998). No frozen soils were encountered at any location along the offshore pipeline route. Soft silts were documented from the seafloor (0 ft) to a depth between 4 to 6 ft thick. The underlying stiff clayey silt horizon reached depths between 18 to 21.5 ft. This stratigraphy corresponds with the relatively flat seafloor with depths averaging 22 ft (Figure 1).

The seafloor rises gently from the 22-ft isobath to the 15 ft isobath where the sediments typically consists of sand, silty sand, with some soft silt, and many pockets and layers of peaty soil. A 4.5 ft thick shoal consisting of uniform fine-grained, clean sand was also identified.

The sediments found in water depths between the 15-ft and 7-ft isobaths are silty sands interbedded with medium stiff silt to the maximum pipe burial depth of 10 ft. Stiff silt underlain by sandy gravel are found below.

Between the 7-ft and 4-ft isobaths, the dominant material is silty sand with thin interbeds of silt and thin organic rich layers. The underlying gravelly sand is shallower than the pipeline depth at Boring D-16 (Figure 2).

Sediments in water depths less than 4 ft and extending to the shoreline consist of thin surface layers of sand and soft silt with the underlying sand and gravel at shallow depths 5 to 6 feet. Frozen ice bound sediments were observed up to 230 ft from shore.

The heterogeneous nature of the sediments encountered in borings located along the selected pipeline route indicate that no one grain-size sample describes the different sediments that will be removed from the pipeline trench. However, a representative grain-size distribution can be estimated by computing the average percent fraction by weight for each sieve size from each sample collected within the sediments slated for trenching. See Tables 3 through 5, attached. Attachment A presents individual sample grain-size distributions and the resulting representative trench material grain-size distribution.

Additional collection of sediment samples for grain size analysis will be conducted during the 2000-2001 winter season along the proposed pipeline routes.

Sediment Chemistry

The USACE and EPA are currently developing a consistent set of procedures for determining sediment quality for dredging activities within Alaska. Guidelines based on recent efforts in the Puget Sound and Lower Columbia River areas of the Pacific Northwest expanded the list of pollutants and chemicals-of-concern to include conventional chemicals-of-concern, metals, high molecular weight polycyclic aromatic hydrocarbons (PAH), and low molecular weight PAH. The sampling design for earlier Liberty Development sediment quality studies did not include all of these parameters, thus, additional sediment quality sampling will be conducted during the winter season of 2000-2001.

Sediment chemistry samples have been collected throughout Foggy Island Bay to quantify natural background concentrations of selected heavy metals, volatile organic compounds (VOCs), semi-volatile organic compounds (SVOCs), and petroleum hydrocarbons (NORTEC 1983; Montgomery Watson 1997, 1998). Prior to 1982, no petroleum exploration occurred within Foggy Island Bay. The NORTEC (1983) study collected numerous sediment chemistry samples prior to drilling of the first exploratory well in Foggy Island Bay, Shell Oil Tern #1.

The barium concentrations for five samples collected at one location prior to 1982 drilling activities varied between 210 and 9,040 mg/kg. Further analyses indicated that the seafloor sediments in the Beaufort Sea are heterogeneous with a patchy nature; thus, it is not uncommon to find large variations in sediment grain-size and trace metal concentrations within samples taken at the same location (NORTEC 1983). The natural variability in sediments is reflected in lead concentrations found in sediments collected in the western half of Foggy Island Bay during evaluation of several proposed pipeline routes associated with the Liberty Development (Montgomery Watson 1997).

Table 2 presents a statistical summary of selected heavy metal concentrations for sediments collected throughout the Beaufort Sea and samples specific to Foggy Island Bay. Within Foggy Island Bay, arsenic, chromium, and mercury exhibit consistent concentrations, while barium and lead tend to be variable. On average, metal concentrations from the pipeline route studies (Montgomery Watson 1997; 1998) are lower than results from a study conducted prior to exploratory drilling in 1982 (NORTEC 1983). Also, most of the heavy metal results from samples collected within Foggy Island Bay are within the range of concentrations found throughout the Beaufort Sea. The only exception is chromium, in which Foggy Island Bay sediments contained a maximum concentration of 34 mg/kg (Montgomery Watson 1997).

In 1998, samples were collected at three depths below the seafloor in order to describe the sediment chemistry along the selected pipeline route. Montgomery Watson (1998) summarized sediment quality criteria as set forth by the Puget Sound Dredged Disposal Analysis, which was developed for dredging operations by EPA Region X (Seattle), USACOE, and the Washington State Department of Natural Resources and Ecology. All heavy metals and VOC, were uniformly below the screening level. One sample collected approximately 9 ft below the seafloor resulted in a concentration of 4-Methylphenol (p-Cresol), a SVOC, that was above the minimum screening level. However, this sample was collected approximately 600 m northwest of the proposed gravel island, and outside of the proposed pipeline trench.

Analyses of samples collected in 1997 throughout the western portion of Foggy Island Bay determined that there is a positive linear correlation between the concentrations of chromium and lead. Also, barium and arsenic levels increase proportionally with increasing chromium concentrations. However, the relationship of these metals to grain-size is also noteworthy. Two linear relationships are present between chromium and the increasing fines (silt and clay) fraction.

Borings were conducted along three proposed pipeline routes or transects. All of the transects started a point immediately west of the proposed gravel island. Transect A extended southeast with landfall east of the Kadleroshilik River. Transect B extended southwest, and closely resembles the current pipeline route. Transect C extended to the Endicott Satellite Drilling Island. Borings along the Transect A, tend to have approximately two-times (2X) higher chromium concentrations for the same percent fines than sediments collected near the proposed gravel island and along Transects B and C. Multiple relationships are also observed between the increasing fines fraction and lead, and to a lesser extent with arsenic. The trends are parallel with metal concentrations increasing as the fine-grained fraction increases, and with Transect A samples having higher metal concentrations than other samples collected toward the west.

The multiple trendlines for a given metal likely indicate multiple sediment sources. Silt dominant sediments deposited at the mouth of the Sagavanirktok River have lower metal concentrations than sediments in the center of the embayment. There are similar distributions for barium, barium sulfate, chromium, and lead. Additionally, arsenic, with concentrations at or near the detection limit, has a similar distribution. Since grain-size distributions have not been affected by human activity, metal concentrations and distribution throughout the western portion of Foggy Island Bay appear to represent natural background concentrations. The extent and nature of previous disposal activities in Foggy Island Bay are described in section 3.7, *Existence and Effects of Previous Disposal*, of this document.

3.5 FEASIBILITY OF SURVEILLANCE AND MONITORING

Surveillance of the disposal site will be performed during the disposal operation on the ice. Direct surveillance of the site during spring breakup however, is not feasible. Aerial surveys could be performed if required; however, their usefulness is questionable because disposed material should be indistinguishable from other bottom sediments after the first major storm of the open-water season. Surveillance and monitoring during the open water season (post construction) would be required to confirm that significant mounding from the disposal of dredged material has not occurred within the disposal area, and that the disposal is in compliance with permit special conditions.

During construction of the Northstar Project, a similar disposal operation plan was approved. Dredged material was temporarily disposed in an approved location. However, all dredged material was recovered and used as backfilling material for the Northstar pipeline system. As a result, no surveillance and monitoring was conducted during the spring 2000 breakup season.

The surveillance and monitoring for the placement of fill material (404 discharge) is addressed in Appendix G, of the DEIS.

3.6 DISPOSAL, HORIZONTAL TRANSPORT, AND VERTICAL MIXING CHARACTERISTICS OF THE AREA

Ice Breakup and Dredged Material Input

Movement of sea ice during spring breakup would distribute the dredged material into the water column. Deposition (fate) of the spoil stockpile into the nearshore Beaufort Sea is determined by:

- Ice breakup and melting
- Overburden material
- Nearby shoals
- Sagavanirktok River overflow

Ice Breakup and Melting

The primary proposed spoil stockpile (Zone 1) is located in the southwest portion of Foggy Island Bay in water depths between 5 and 8 ft (1.5 and 2.4 m). The ice cover is seasonal, with landfast ice formation initiated in October, becoming continuous nearshore by mid-October, and remaining until breakup in June (Vaudrey 1997). By late winter, the seasonal ice generally is about 6.5-ft (2 m) thick (Vaudrey 1997).

The spoil would likely sink to the seafloor directly beneath the ice pad as the ice melts in situ. The weight of the overburden will prevent the ice from lifting off of the ocean bottom. Some ice floe fragments, which have minimal spoil on the ice surface, may start to float away during breakup; however, most of these fragments will probably run aground on the 4- to 5-ft (1.2 to 1.5 m) deep shoals to the north and northeast of the dump site.

Effects of Overburden Material

Even if spoil remains on relatively solid ice at breakup, the sea ice will not have sufficient buoyancy to lift off of the seafloor. Since sea ice has a density of approximately 0.9 lb/ft³ (0.07 g/m³) it provides about 6.4 pounds per square ft (lb/ft²) (151 kg/m²) of buoyancy (lifting capacity) per foot of water depth. This amounts to about 50 lb/ft² in 8 ft (2.4-m) of water, the maximum depth at the dump site. The spoil weighs about 100 lb/ft³. If it is assumed that the spoil is stacked to a minimum height of 1 ft (0.3 m), there is a safety factor of two against the sea ice becoming ungrounded and carrying the spoil away during breakup.

Effects of Nearby Shoals

Typically Zone 2A and that portion of the grounded ice pad around the spoil perimeter at Zone 1 may have only a small amount of spoil on the ice surface. It is possible that these “dirty” areas could float away during breakup. However, most of these ice floe fragments would probably become grounded on nearby shoals (4- to 5-ft [1.2 to 1.5 m] deep) located within a mile to the north and northeast of the primary dumpsite. These regrounded floe fragments are likely to stack up in which any remaining ingrained sediment could be deposited. Due to the expected small amounts no appreciable effects are anticipated.

Effects from River Overflow

About a month prior to breakup, the east fork of the Sagavanirktok River overflows the sea ice in southwestern Foggy Island Bay (Vaudrey 1997). During an average year, Zone 1 would be located inside the overflow limits. The warmer river water will initiate surface melting and the dirty (dark) ice would absorb more solar radiation to hasten the melting process. By the time that breakup of the floating sea ice occurs in central Foggy Island Bay, most of the ice pad containing the spoil will have melted in situ.

Comparison with Sagavanirktok River Deposition During Overflow

Conservatively estimated, less than 10 percent of the maximum spoil (< 10,000 yd³ [7,650m³]) will float away from the dump site (Vaudrey 1997). This volume is equivalent to a silt layer (1/8-inch thick [0.3 cm]) covering 1 square mile (259 hectares [ha]) of sea ice. In contrast, the Sagavanirktok River overflow typically covers about 20 square miles (5,180 ha) of sea ice each year (Vaudrey 1997).

Active physical processes will redistribute spoil deposited in the nearshore waters of Foggy Island Bay. Zone 1 is located in the distal portion of an eastern distributary of the Sagavanirktok River. For water depths less than 6.5 ft (2 m), if any spoil deposit produced a bathymetric feature such as a shoal, seasonal ice formation and grounded ice movements should remove the artificial bathymetric feature within one year. In deeper waters, ice movement will diminish the size of any artificial nearshore feature that results from spoils disposal.

Stockpile Related Sediment Suspension and Deposition

Sediment Deposition

Sediment chemistry analyses for potential contaminants of concern as presented in Section 3.4.3 demonstrate that dredged material contain concentrations within naturally occurring levels found throughout Foggy Island Bay and the Central Beaufort Sea. However, there is concern that the sediment stored on the ice surface at stockpile Zones 1 and 2B may produce a sediment plume that could adversely impact the Boulder Patch community as the ice melts and the sediment settles to the seafloor.

During sea-ice melting, it is anticipated that approximately 90 percent of the spoil material would fall through the water column within the vicinity of the stockpile. Less than 10 percent of the maximum spoil volume (<10,000 yd³ [7,650m³]) is estimated to float away from the stockpile site (Vaudrey 1998). There are two reasonable depositional scenarios:

- 1) The stockpile material will be partially frozen or cohesive, and thus, the material will fall into the water as clumps. This will result in most of the material settling at the stockpile location, with a maximum thickness of 1 ft (30.5 cm) and limited dispersion on the seafloor; or
- 2) The stockpile material will be non-cohesive and sufficiently thawed that a majority of the sediment grains will be released as individual grains or particles.

To evaluate effects of disposal, scenario 2 was used because it would result in greater water quality and substrate effects. It is unlikely that all of the stockpiled material would thaw and be released into the water as individual particles. However, the following narrative provides a conservative approach to determine the maximum sedimentation that could theoretically occur.

To determine the probable maximum particle deposition from a stockpile, Stokes' Law is used to calculate the mean fall velocity (w) of particles of a unique diameter through the water column. The fall velocity can be computed by the following equation:

$$w = \frac{gd^2 \left(\frac{\gamma_s - \gamma}{\gamma} \right)}{18\nu} \quad (1)$$

where:

w is fall velocity (m/s)

g is the acceleration due to gravity (9.75 m/s²)

d is a particle-size diameter based on the average trench material grain-size distribution

γ_s is the specific gravity of the particle (2.6)

γ is the specific gravity of seawater (1.026)

ν is the kinematic viscosity of seawater (1.80x10⁻⁶ m²/s)

The effective theoretical downstream distance required to capture suspended particles can be calculated using the following equation:

$$D = \left(\frac{\mu}{w} \right) H \quad (2)$$

Where:

μ is the current speed (m/s)

w is the fall velocity for a given particle size (calculated in equation #1)

H is the height of the water column (m)

Since the maximum downstream distance can be computed for a variety of particle sizes, sediment deposition from each stockpile can be described (Appendix B). Observations throughout the nearshore Beaufort Sea indicate that water movement is a result of wind stress on the water surface, with movement oriented downwind and parallel to the bathymetric contours.

If the Zone 1 stockpile thickness is regulated to a maximum height of 1 ft (30 cm) and a maximum volume of 100,000 yd³ (76,500 m³), the maximum thickness of dredged material would be approximately 120 cm (8.4 inches) in the vicinity of the stockpile. During easterly winds, a sediment plume would be generated toward the north, with the plume axis parallel to bathymetry (Figure 3). Similarly, westerly winds would create a sediment plume east of the stockpile. Sediment deposition rapidly decreases to a thickness of 10 mm (0.4 inches) within a radius of about 530 m (1,740 ft) from the stockpile. Within 1,000 m (3,280 ft) of the stockpile, sedimentation is predicted to be less than 5 mm (0.2 inches), a thickness that is expected not to be detectable.

Any reduction in the stockpile volume would reduce the thickness of the sediments deposited by the plume. However, a smaller volume would not reduce the extent of the plume, since the downstream distance of the plume is dependent on grain-size diameter and ambient current velocity (i.e., speed and direction). There is a slight difference in thickness between the plumes since easterly winds occur approximately 70 percent of the time and westerly winds occur approximately 30 percent of the time during the open-water season.

It is anticipated that the resulting deposition from a sediment plume created by stockpiled material within Zone 2 would have an insignificant thickness since the maximum volume is no more than 10,000 yd³ (76,500 m³) for the surface area of Zone 2 (Figure 4). Sedimentation resulting from material stored at Zone 2 would be no greater than 8 mm (0.3 inches) at the stockpile location, and 1 mm (0.04 inches) approximately 180 m (600 ft) from the stockpile location.

Stokes' Law assumes that water conditions approximate quiescence and does not take into account the role wave action would play in resuspending particles. As a general rule, if wavelength is greater than four times the local water depth, then wave-induced currents would be sufficient to resuspend loose (fine) bottom sediments, even with relatively small wave heights. Using standard wave prediction formulas or charts, the next step is to calculate the minimum winds necessary to cause waves having lengths greater than four times the local depth at both disposal zones. Based on the local water depths, a 50-mile per hour (mph) wind would be necessary to resuspend bottom sediments in Zones 1 and 2. Supporting computations are included in Appendix C.

In Foggy Island Bay, as elsewhere along the entire Beaufort Sea coast, water column movements are due almost entirely to the frictional stress of wind on the water surface. For resuspended sediments to be transported from the deposition sites (Zones 1 and 2) to the Boulder Patch, water column movements must be directed from the deposition sites toward the Boulder Patch. The Boulder Patch lies mostly to the north of the two deposition sites, so our concern is limited to southerly winds that generate waves capable of resuspending bottom sediments at the two deposit sites. Analyses of meteorological data collected in Foggy Island Bay (USACE 1987-1994), show that the wind blows from southerly directions (SSE to SSW) only 5 percent of the time and, further, the maximum wind speed of record from these directions is only 8 mph. This data suggest a reasonable conclusion that the probability of occurrence of winds of 50 mph is virtually zero.

Suspended Sediments

The stockpile sites are located immediately offshore of the eastern distributary of the Sagavanirktok River, a major suspended sediment source along the Beaufort Sea. Total suspended solids (TSS) analyses for water samples collected throughout Foggy Island during the open-water season indicated concentrations up to 79 mg/l (URS Greiner Woodward Clyde 1998). During sea ice breakup, suspended sediments associated with river discharge will be quite high, typically over 50 mg/l.

If the stockpile materials are cohesive, or partially frozen, it is anticipated that majority of the materials would settle to the seafloor in the vicinity of the stockpiles. If this occurs, the amount of TSS would be relatively small in comparison to ambient conditions. In the event that the stockpile materials are dispersed to the theoretical

maximum extent, TSS concentrations would also be relatively small since the resulting sediment plume will cover a large area.

3.7 EXISTENCE AND EFFECTS OF PREVIOUS DISPOSAL

Past Activities

Shell Oil Company constructed a gravel island, Tern Island, at the mouth of Foggy Island Bay in 1982 to support exploratory drilling. Wastewater discharge permits under the National Pollutant Discharge Elimination System (NPDES) allowed for the discharge of drilling muds, cuttings, and fluids onto the surrounding sea ice during winter and direct discharge into Beaufort Sea waters during the summer open-water season. Drilling muds used at the site in the early 1980s are classified as potassium chloride (KC/Polymer) muds. A total of 2,800 bbl of drilling effluents were periodically discharged between June and August 1982 on the northwest side of Tern Island, approximately 15 m from the island shoreline (NORTEC 1983). During the winter, approximately 700 bbl of drilling effluents were transported to a sea ice disposal area approximately 150 m northwest of the island. Well cuttings were transported by heavy equipment and placed on island slope immediately adjacent to the drilling effluent outfall during periods of open water. The island slope was sufficient for the well cutting to move downslope, resulting in deposition on the submerged island slope.

An environmental study was developed to quantify the effluent dispersion and diffusion upon release to the marine environment, and to assess the fate of these discharges (NORTEC 1983). Seafloor geochemical samples were collected in the vicinity of Tern Island, along the principle axis of the currents prior to and after discharge. Results indicated that oil and gease concentrations were elevated above background levels approximately 35 m from the outfall, and elevated barium concentrations were observed 100 m from the island. The study concluded that it is possible that deposition and accumulation of drilling effluents may occur locally, that is within 100 m of the discharge (NORTEC 1983).

BPXA drilled an exploration well (Liberty #1) on Tern Island during the winter of 1997. Drilling muds and cuttings, deck drainage, sanitary and domestic wastewater, and miscellaneous wastes including excess cement slurry, and desalination unit wastes were discharged under the NPDES permit. Approximately 16,200 bbl of muds and cuttings were transported to a sea ice disposal site located approximately 2,100 m (7,000 ft) southeast of Tern Island in 18 to 20 feet of water. Sanitary and domestic wastewater discharges were placed at the muds and cuttings disposal site, or through a discharge line with an outfall on the southeast side of Tern Island. Bioassays indicated that the drilling fluid was considered non-toxic (AMBAR Technical Labs 1997).

During ice road construction, a truck broke through the ice southwest of Tern Island in January 1997. Approximately 10 gallons of diesel and 0.5 gallons of hydraulic fluid spilled into the open water. The spilled material was later recovered and properly disposed.

It is unlikely that the sediments along or near the pipeline route have been disturbed by past activities. These activities were located east of the pipeline route, were of limited duration, and resulted in the minimal discharge of drilling muds and cuttings. Geophysical surveys conducted throughout the Liberty Development Project area did not identify any anthropogenic structures or observable effects from human-use activities. Furthermore, the linear correlation between grain-size distribution and heavy metals imply that there has been no measurable input of pollutants as a result of human activity. Thus, metal concentrations and distribution throughout the western portion of Foggy Island Bay appear to represent natural background concentrations.

Results from these studies indicate that the seafloor sediments at the trench location are essentially the same as the substrate at the proposed disposal sites, with no known existing or historical pollution sources. Thus, the dredged material slated for marine disposal meets the testing exclusion criteria as specified in 40 CFR 227.13(b)(3).

3.8 INTERFERENCE WITH OTHER USES OF THE OCEAN

Other known uses of the disposal site area are boating and fishing activities for subsistence, recreation and scientific study. No significant impact to these activities is expected for the following reasons:

- The materials to be dredged are uncontaminated sediment and generally indistinguishable from natural background conditions.
- Navigational hazards will not be created by the work
- Dispersion of the spoil (excess dredged material) piles will occur at a time when boat travel typically does not occur (during breakup).

3.9 EXISTING WATER QUALITY AND ECOLOGY

The Beaufort Sea has been studied for nearly two decades, so the oceanographic behavior of the region is well-understood. As with the Beaufort Sea, water dynamics within Foggy Island Bay are governed by recent wind history and proximity and volume of freshwater sources. Other factors that influence oceanographic conditions include air temperature, precipitation, bathymetry, earth rotation (Coriolis effect), and sea ice cover. No appreciable adverse effects to water quality and Foggy Island Bay ecology are anticipated as a result of ocean disposal of dredged material, should it be undertaken by the applicant.

Salinity and Temperature

Marine waters are generally cold, -2° to 5°C (28° to 41°F), and saline (28 to 30 ‰) (Craig 1984; Colonell and Niedoroda 1990). Temperature and salinity within the central Beaufort Sea nearshore zone are strongly influenced by the prevailing summer wind velocity (direction and speed), the proximity of freshwater discharge by coastal river systems, and the presence of sea ice.

Summer Conditions (Open Water)

Information presented herein is derived from *Endicott Environmental Monitoring Program Final Reports* (USACE 1987-1993). During the summer open-water season, the timing and rate of discharges from the Sagavanirktok, Kadleroshilik, and Shaviovik rivers determine the amount of freshwater available for distribution in the marine environment of Foggy Island Bay. The open water typically occurs in late June to early July and, as warming continues into summer, the sea-ice melts, resulting in about 75 days of open water. After sea ice breakup, wind speed and direction become the key factors in determining the fate of freshwater advected along the coast. Wind speed and direction also influence water level variations that, in turn, play a key role in the exchange rates between brackish nearshore and offshore marine waters. Other agents controlling currents include the small (<12 inches [30 cm]) astronomical tide and occasionally large 3 to 7 ft (1 to 2 m) storm surges and, much more locally, river discharge adjacent to river deltas.

The Sagavanirktok River delta, located immediately west of Foggy Island Bay, discharges substantial volumes of freshwater into the nearshore environment. A small distributary of the Sagavanirktok River empties into the embayment along the western shore. During and immediately after sea ice breakup, there is a freshwater (~3 to 6 ppt) surface layer up to 4 m thick that encompasses the bay and covers the marine (~30 ppt) waters. This two-layer or stratified water column is a short-term event, persisting on average for only 1 or 2 weeks. As the sea ice diminishes, winds mix the waters of Foggy Island Bay, creating an unstratified (uniform) water column of brackish (~12 to 17 ppt) waters. As summer progresses, the water column typically remains unstratified, with salinity gradually increasing to marine (>30 ppt) conditions by mid-September. These unstratified marine conditions persist into freezeup.

Wind history (speed and direction) is of prime importance in determining the fate of freshwater advected along the coast by currents during the open-water season. The prevailing summer winds along the Beaufort Sea coast are from the east, so the nearshore currents respond to this wind stress by flowing westward. This current regime transports river discharges westward along the shore such that freshwater is mixed with the ambient nearshore waters.

Two scenarios permit the temporary formation of a stratified water column within Foggy Island Bay:

1) upwelling of marine bottom waters, and 2) sufficient freshwater discharge during westerly winds. Under strong easterly winds, regional coastal upwelling draws cold, saline, bottom water into the nearshore environment. This results in a temporary stratified, two-layer water column consisting of brackish (~20 ppt) surface waters and a bottom layer of cold, saline (>30 ppt) waters. When sufficient freshwater enters Foggy Island Bay and mixes with the upper portion of the water column, a surface layer forms that has lower salinities than the underlying waters.

During easterly winds, the freshwater plume is restricted to the shallow nearshore waters and flows out of Foggy Island Bay, around Point Brower and toward the west. Thus, the freshwater discharge does not mix with the waters of Foggy Island Bay, with the exception of a narrow band of nearshore water immediately adjacent to the western shore. However, during westerly winds, the freshwater plume mixes with the surrounding bay waters, creating a stratified water column.

Sea ice is prevalent throughout the central Beaufort Sea during early summer (June to mid-July), limiting wind stress applied to the water column. The average current speed during June and July is only about 0.1 knots (kt) [5 centimeter/second (cm/s)]. As the open-water season progresses, and the area is freed of large concentrations of sea ice, the water surface is more exposed to the prevailing winds. Then the average current speed (August-September) is about 0.3 kts (14 cm/s) with a maximum observed speed of 1.3 kts (68 cm/s).

Winter Conditions (Ice-Covered)

During winter, the Beaufort Sea is covered by sea ice that begins to form in late September. Freezup of the waters is completed by the end of October, with ice growing to a maximum thickness of 2.3 m (7.5 ft) by April (MMS 1996). Ice cover persists on average for 290 days until spring warming results in river breakup, and subsequent sea ice melting near the river and stream deltas. Temperature and salinity profiles collected under the sea ice within the Beaufort Sea exhibit uniform cold, 29°F (-1.5°C), saline (32.4 ppt) marine waters (Montgomery Watson 1997, 1998). Under ice observations in the Beaufort Sea indicate very low current speeds aligned with bathymetry, which results in an easterly or westerly flow. The average current speed observed during ice-covered conditions is less than 0.04 kt (2 cm/s) (Montgomery Watson 1997).

While the current meters employed during under-ice studies are generally insensitive to speeds below 0.04 kts (2 cm/s), the data do not indicate stagnant conditions. Heavy brine formed by the thickening sea ice could produce a stratified water column in stagnant or near-stagnant conditions; however, low current speeds (e.g., less than 2 cm/s) are sufficient to disperse any such brine through the water column and minimize or eliminate resulting under-ice vertical stratification. The typical water column structure observed under sea ice in the Beaufort Sea is uniform, with no temperature, salinity, or density stratification.

Dissolved Oxygen

During the open-water season, dissolved oxygen levels in Foggy Island Bay are usually high, typically above 10 mg/L (URS Greiner Woodward Clyde 1998). During open water, the highest dissolved oxygen concentrations occur in the colder, more saline water located near the bottom of the water column (Woodward-Clyde 1981). Under winter ice-cover, respiration by planktonic and other organisms continues, but atmospheric exchange and photosynthetic production of oxygen cease. Throughout the ice-covered period, dissolved oxygen concentrations in areas with unrestricted circulation seldom drop below 6 mg/L. Under-ice dissolved oxygen concentrations in February 1997 and March 1998 along the proposed Liberty pipeline route ranged from 7.4 to 13.2 mg/L (Montgomery Watson 1997, 1998).

Turbidity and Suspended Sediment

Suspended sediment is introduced naturally to the marine environment through river runoff and coastal erosion (MMS 1996) and is resuspended during summer by wind and wave action. Satellite imagery and suspended particulate matter data suggest that turbid waters are generally confined to depths less than 16 ft (5 meters) and are shoreward of the barrier islands. In mid-June through early July, the shallow nearshore waters generally carry more suspended sediment as a result of increased sediment load discharged from the rivers (Sagavanirktok, Kadleroshilik and Shaviovik), and thus, very high turbidity is observed adjacent to the river mouths. Storms, wind and wave action, and coastal erosion increase turbidity in shallow waters periodically during the open-water season. Turbid conditions persist in areas where the sea floor consists primarily of silts and clays as compared to areas having a predominately sand bottom.

Suspended sediment concentrations are governed primarily by wind-induced waves and freshwater input from the Sagavanirktok River and other major rivers (USACE 1987). Britch et al. (1983) found peak suspended sediment concentrations were associated with intervals of highest significant wave heights. The 1983 study reported a maximum TSS value of 324 mg/L at a nearshore station and an average of 45 mg/L. During and immediately after storms, naturally occurring suspended sediment concentrations exceeded 50 mg/l near Tern

Island (NORTEC 1983). During the 1998 open-water season, the average TSS value was 30 mg/L, similar to the 1983 study (URS Greiner Woodward Clyde 1998). In-situ turbidity measurements collected during the 1998 open-water season ranged between 1 and 173 nephelometric turbidity units (NTU). There was no correlation between TSS and turbidity values from samples collected within Foggy Island Bay (URS Greiner Woodward Clyde 1998).

The presence of ice cover limits wave action resulting in decreased turbidity (MMS 1996). Under-ice TSS values along and in the vicinity of the proposed Liberty pipeline route ranged from 2.5 to 76.5 mg/L (Montgomery Watson 1997, 1998); field-measured turbidity for February and March under-ice conditions ranged from 1 to 35.6 NTU, and laboratory-measured turbidity ranged from 0 to 24 NTU (Montgomery Watson 1997, 1998).

Nutrients

Nitrogen and phosphorous are introduced to Foggy Island Bay by river runoff and coastal peat erosion. Levels decline in the summer, after breakup, and are considered limiting by the end of summer (Bureau of Land Management [BLM] 1979). Schell (1982) found nitrogen availability limits most marine plant growth during the arctic summer season. The dominant kelp found in Stefansson Sound (*Laminaria solidungula*) is one of the few marine plants that has developed a life history strategy to contend with nutrient limitation in summer and restricted light conditions of winter (e.g., Dunton 1990).

Trace Metals

Trace metals are introduced naturally to the central Beaufort Sea through river runoff (relatively unpolluted by humans), coastal erosion, atmospheric deposition, and natural seeps. Since there is little industrial discharge activity in this region, most trace metals concentrations are low in the Beaufort Sea (MMS 1996). Montgomery Watson collected under-ice water quality samples along the proposed right-of-way in 1998 (Montgomery Watson 1998). The samples were analyzed for arsenic, barium, chromium, lead, and mercury. Arsenic concentrations ranged from less than the minimum report detection limit of 0.002 mg/L to 0.0226 mg/L. Barium was detected at concentrations-- ranging from 0.0175 mg/L to 0.0551 mg/L. Chromium, lead, and mercury concentrations were below detection levels.

Open-water concentrations for arsenic, chromium, lead, and mercury were below detection limits (URS Greiner Woodward Clyde 1998). Barium concentrations were determined to range from 0.010 to 0.021 mg/L, with the distribution corresponding to the brackish surface waters associated with the Sagavanirtok River discharge.

Hydrocarbons

Background water hydrocarbon concentrations in the Beaufort Sea tend to be low, generally less than one part per billion (ppb), and appear to be biogenic (MMS 1996).

3.10 POTENTIAL FOR RECRUITMENT OF NUISANCE SPECIES

Attraction of marine species to the spoil piles either during stockpiling or dispersion is not expected. Since the disposed material is similar to the substrate in the disposal area(s), it is not expected to contain large amounts of infaunal organisms, nutrients, or organic matter, which could serve as an attractant to birds or mammals. Similarly, it is unlikely to provide increased nutrient load to the water column. In addition, biological activity (decay) in the piles would be minimal due to cold and dry winter (frozen) conditions.

3.11 EXISTENCE OF SIGNIFICANT NATURAL OR CULTURAL FEATURES

The Boulder Patch Community could be considered a significant natural feature (see Section 3.2). However, The Boulder Patch community is not located in the immediate vicinity of either of the disposal areas, and any ice movement during breakup should place the spoil piles landward of known Boulder Patch areas. There are no known cultural features in the offshore areas that could be affected by the proposed disposal (LGL et al. 1998).

IV. GENERAL CRITERIA

As specified in 40 CFR Section 228.5, five general factors must be considered in selection of disposal sites in conjunction with those specified factors discussed above. The following present an evaluation of the environmental impact associated with disposal of dredged material based on these general criteria.

4.1 Minimal Interference with Other Activities

Little to no interference with other activities is expected because construction and disposal activities will occur prior to open-water season. Disposed material will be dispersed in a thin layer on the seafloor by the time ice moves out of the area and other activities are possible. The short duration of the disposal activity, approximately two months, minimizes the time that hunting or recreation in the area might be affected. Snow machine traffic associated with subsistence activities may occur infrequently in the vicinity of the disposal site, resulting in the minor inconvenience of traveling around spoil piles. No commercial fisheries are present in the disposal area.

4.2 MINIMAL CHANGES IN WATER QUALITY

Material to be disposed of consists of sand and silt of local origin, and thus, the spoil are believed to contain no appreciable amounts of chemically contaminated materials. Low concentrations of naturally occurring metals are found throughout the project area and have been detected in both surficial and sub-bottom sediment samples. Natural variability of heavy metals and other chemical parameters will typically occur below screening level criteria as set forth in the Puget Sound Dredged Disposal Analysis (Montgomery Watson 1998). No significant impact on water quality is anticipated due to the low concentrations of naturally occurring metals and significant dispersion of disposed material expected to occur during spring breakup.

Marine water in the project area is likely to be highly turbid during spring breakup and any time high wind events occur during the open-water season. The proposed disposal of dredged material is not expected to have significant impacts on water quality since disposal would be of short duration, and the timing of deposition coincides with naturally-occurring high turbidity levels.

4.3 INTERIM SITES WHICH DO NOT MEET CRITERIA

There are no existing interim disposal sites in the area.

4.4 SIZE OF SITES

Ocean Dumping of Dredged Materials (Excess offshore pipeline construction spoils) Applicant's proposed plan	DISPOSAL SITE FOOTPRINT LIMITS (FEET)	VOLUME (CUBIC YARDS)	AREA (ACRES)
Disposal Zone 1 (limits)	2,000 x 5,000	up to 100,000	230
Disposal Zone 2 (limits)	32,300 x 200	up to 10,000	150

The Zone 1 disposal site is located on the west side of the pipeline right-of-way on grounded sea ice and seaward/outside of the -5-foot MLLW. Maximum dimensions of the site are 5,000 feet by 2,000 feet (230 acres). For dredged spoils that cannot be used as backfill, Zone 1 would serve as the designated disposal site (not to exceed 100,000 cubic yards). Spoils placed in Zone 1 for disposal would be groomed to an average height of approximately one-foot to minimize the potential for mounding on the sea floor. Assuming that up to 100,000 cubic yards of spoils could be disposed of on the site to a height of one-foot, about 27 percent of Zone 1 (about 62 acres) would be used for actual disposal.

The Zone 2 disposal site (150 acres) is a 200-foot wide section along the west side of the pipeline trench from Liberty Island to shore. Zone 2a is that segment in water depths less than approximately 16 feet; and, Zone 2b is that segment located on floating ice, in water depths greater than 16 feet. Spoils in Zone 2a would be groomed to maintain an approximate height not to exceed one foot. Spoils placed in Zone 2b would be groomed to a maximum height of less than 2 feet. It is BPXA's intent to clear Zone 2 of all dredged material/spoils by the end of construction. This would be accomplished by scraping the ice with heavy equipment leaving, at most, a veneer of dirty ice a small amount of sediment remaining in the frozen matrix. This is dependent upon weather and ice conditions.

See section 2.2, above for description of project alternatives (Zones 3, 4 and 5). See Figures II.C1. and C.2.; and Sections IV. C1.c. and d. of the EIS.

4.5 SITES OFF THE CONTINENTAL SHELF

A disposal site located off the OCS is not practical or reasonable due to safety and transportation difficulties in multi-year sea ice and the distance to such a site. Environmental impacts may be greater at a site beyond the OCS in comparison to the nearshore site, where seasonal bottomfast ice disrupts the benthic community annually and storms frequently redistribute sediments.

V. OCEAN DUMPING ANALYSIS AND FINDINGS (Preliminary)

5.1 DETERMINATION OF ENVIRONMENTAL ACCEPTABILITY OF DREDGED MATERIAL FOR OCEAN DISPOSAL

Existing geotechnical studies indicate that about 65 percent of the sediments are considered to be fines, that is material with particle diameters less than 0.075 mm. [Note: The grain size distribution for dredged material at the Northstar test trench was found to be about 50 percent fines (less than 0.075 mm) which is courser than the grain size distribution collected within Foggy Island Bay.] Background studies conducted for BPXA and the analysis within the DEIS for the Liberty Development Project prepared by USDOJ- MMS, determined that these materials are uncontaminated marine sediments that would be disposed of in a similar environment, therefore meeting the exclusion criteria as stated in 40 CFR 227.13(b). Sediments and sub-bottom materials within the excavation and disposal areas are not known to contain significant anthropogenic contaminants. Small concentrations of metals consistent with background levels were determined from monitoring activities in the Alaskan Beaufort Sea. No adverse impact on sediment or water quality is anticipated from low concentrations of metals present in the sediment. Disposed materials are substantially similar to the substrate materials along the entire nearshore area at Foggy Island Bay including the proposed disposal sites.

5.2 NEED FOR OCEAN DISPOSAL

Ocean dumping is the preferred disposal method because of the salt content of the dredged material. Disposal on uplands is not possible because almost the entire land surface up to 60 miles (97 km) inland is wetland. Negative impacts to wetlands from saline marine trench spoil are substantially greater than the temporary impacts associated with ocean disposal. Consideration was also given to back-haul the excess dredged material for disposal within the gravel mine site (to be used as material for mine site rehabilitation) with the floodplain of the Kadleroshilik River. This alternative was dropped from detailed consideration due to the salt content of the material that could affect the rehabilitation goal to provide over-wintering fish habitat within the freshwater Kadleroshilik River.

5.3 IMPACT OF THE PROPOSED DISPOSAL ON AESTHETIC, RECREATIONAL, AND ECONOMIC VALUES

The proposed ocean disposal would have no appreciable long-term adverse impacts on the aesthetic, recreational, or economic values of the area. The short-term turbidity increase likely will be masked by

background turbidity. The short-term stockpiling of dredged material on the ice for disposal would occur during the winter months, minimizing aesthetic impacts.

5.4 IMPACT OF THE PROPOSED DISPOSAL ON OTHER USES OF THE OCEAN

No significant adverse impacts are anticipated on other known ocean uses such as commercial, recreational, or subsistence fishing; subsistence hunting; navigation; exploitation of living marine resources; exploitation of non-living marine resources (including sand and gravel or other mineral deposits, oil and gas exploration, or structural development); and scientific study.

5.5 FINDINGS (PRELIMINARY)

The material to be dredged was evaluated in accordance to the criteria set forth in 40 CFR 227 and determined suitable for ocean disposal. The proposed ocean disposal sites in Foggy Island Bay were evaluated in accordance with criteria set for in 40 CFR 228.5 and 228.6 and determined to be suitable for disposal of dredged material.

On the basis of this evaluation, I find that the proposed transportation of the excess trench dredged material for the purpose of disposing of it in ocean waters, and the acceptability of the proposed Foggy Island Bay disposal sites for this dredged material would not unreasonably degrade or endanger human health, welfare, or amenities or the marine environment, ecological systems, or economic potentialities.

The following Tables and Figures were extracted from the URS Greiner Woodward Clyde report entitled: Section 103 Marine Protection, Research and Sanctuaries Act, Dredged Material Disposal Site Evaluation, In Support of the Liberty Project US Army Corps of Engineers Permit Application, 1998, prepared for BP Exploration (Alaska) Inc. unless otherwise noted.

TABLES

1. Species Expected To Occur in the Disposal Area
2. Heavy Metal Concentrations for Sediment
3. Applicant's Preferred Pipeline Alignment--Bore Hole Descriptions
4. Applicant's Preferred Pipeline Alignment--Grain-Size Results
5. Estimated Silt and Clay Volume for Offshore Portion of Pipeline Alternatives based on Design Trench Dimensions
6. Estimated Silt and Clay Volume for Offshore Portion of Pipeline Alternatives based on Maximum Excavation Limits

ATTACHMENT - FIGURES

Figure numbers (Original Figures may be found within the DEIS)

- | | |
|---------|---|
| III.C-4 | Maximum Area of Boulder Patch Exposure to Suspended Solids From Liberty Zone 1 |
| III.C-5 | Sediment Outfall from Stockpile Zone 1 |
| IV.C-3 | Maximum Area of Boulder Patch Exposure to Suspended Solids from Zone 3 Ocean Disposal of Excavated Spoils |
| III.C-3 | Maximum Area of Boulder Patch Exposure to Suspended Solids from Liberty Pipeline Construction (Winter) |
| IV.C-1 | Maximum Area of Boulder Patch Exposure to Suspended Solids from Eastern Pipeline Route |
| IV.C-2 | Maximum Area of Boulder Patch Exposure to Suspended Solids from Tern Pipeline Route |

Table 1.
SPECIES EXPECTED TO OCCUR IN THE DISPOSAL AREA

Common Name	Scientific Name
Marine and Anadromous Fish	
Arctic cisco	<i>Coregonus autumnalis</i>
Least cisco	<i>Coregonus sardinella</i>
Char	<i>Salvelinus</i> spp.
Broad whitefish	<i>Coregonus nasus</i>
Arctic cod	<i>Boregadus saida</i>
Fourhorn sculpin	<i>Myoxocephalus quadricornis</i>
Benthic Organisms	
Mysids	<i>Mysis relicta</i>
Isopods	<i>Mesidotea entomon</i>
Gammarid amphipods	<i>Omisimus glacialis</i>
	<i>Omisimus litoralis</i>
	<i>Gammarus setosus</i>
	<i>Pontoporeia affinis</i>
Marine Mammals	
Bowhead whale	<i>Balaena mysticetus</i>
Ringed seal	<i>Phoca hispida</i>
Bearded seal	<i>Erignathus barbatus</i>
Polar bear	<i>Ursus maritimus</i>
Birds	
Greater White-Fronted Goose	<i>Anser albifrons</i>
Brant	<i>Branta bernicla</i>
Common Eider	<i>Somateria mollissima</i>
King Eider	<i>Somateria spectabilis</i>
Spectacled Eider	<i>Somateria fischeri</i>
Oldsquaw	<i>Clangula hyemalis</i>
Steller's Eider	<i>Polysticta stelleri</i>
Gyr Falcon	<i>Falco rusticolus</i>
Snowy Owl	<i>Nyctea scandiaca</i>
Willow Ptarmigan	<i>Lagopus lagopus</i>
Semipalmated Sandpiper	<i>Calidris pusilla</i>
Baird's Sandpiper	<i>Calidris bairdii</i>
Pectoral Sandpiper	<i>Calidris melanotos</i>
Dunlin	<i>Calidris alpina</i>
Red-Necked Phalarope	<i>Phalaropus lobatus</i>
Common Name	Scientific Name
Red Phalarope	<i>Phalaropus fulicaria</i>
Glaucous Gull	<i>Larus hyperboreus</i>
Glaucous-Winged Gull	<i>Larus glaucescens</i>
Arctic Tern	<i>Sterna paradisaea</i>
Common Raven	<i>Corvus corax</i>

Table 2 . Heavy metal concentrations for sediments

Investigation	Location	Arsenic (mg/kg)	Barium (mg/kg)	Chromium (mg/kg)	Lead (mg/kg)	Mercury (mg/kg)
1982 Tern Island (NORTEC 1983) ¹	Foggy Island Bay	no analysis	30 minimum 121 (537[†]) average 360 (9040 [†]) maximum	13 minimum 19 average 27 maximum	12 minimum 16 average 20 maximum	no analysis
Proposed Liberty Pipeline Routes (Montgomery Watson 1997)	Foggy Island Bay	3 minimum 5.5 average 11.4 maximum	29 minimum 67.5 average 194 maximum	7.2 minimum 18.5 average 34 maximum	2.79 minimum 10.1 average 67.8 maximum	‡ all sample results were deemed invalid by the laboratory since the relative percent difference (RPD) for duplicate analyses exceeded acceptance limits.
Selected Liberty Pipeline Route (Montgomery Watson 1998)	Foggy Island Bay (pipeline route)	3.3 minimum 5.5 average 11.2 maximum	23 minimum 45 average 86 maximum	5.4 minimum 12.2 average 27 maximum	2.2 minimum 5.4 average 13.9 maximum	No Detect minimum 0.035 average 0.085 maximum
Northstar Development Pilot Offshore Trenching Program (Montgomery Watson 1996)	Offshore of Stump Island (Site C)	5.0 minimum 7.1 average 16 maximum	46 minimum 63 average 122 maximum	10 minimum 16.6 average 21 maximum	No Detect minimum 23 maximum	Not detected
Beaufort Sea Planning Area Oil & Gas Lease Sale 144 (MMS 1996) ²	Beaufort Sea	no analysis	185 minimum 745 maximum	17 minimum 19 maximum	3.9 minimum 20 maximum	0.02 minimum 0.09 maximum

¹ **Samples collected prior to exploratory drilling.**

² Regional summary.

[†] Five samples collected at Station 1 resulted in barium concentrations ranging between 120 and 9040 mg/L.

[‡] Laboratory duplicates were conducted on field samples, resulting in differences of values greater than accepted.

Table 3. Applicant's Preferred Pipeline Alignment–Bore Hole Descriptions.

Bore Hole	Distance along Pipeline Alignment (feet)	Top of Stratigraphic Unit (MLLW ft)	Bottom of Stratigraphic Unit (MLLW ft)	Sediment Description	USCS Designation
D-5	0	0	-22	Water	Water
D-5	0	-22	-27.5	Silt	ML
D-5	0	-27.5	-42	Clayey Silt	MH
D-5	0	-42	-47.5	Silty Sand	SM
D-5	0	-47.5	-59	Sandy Gravel	GW
D-5	0	-59	-64	Sandy Silt	ML
D-5	0	-64	-86	Sand	SP-SM
D-5	0	-86	-96	Sandy Gravel	GP
D-5	0	-96	-99	TD	TD
D-6	2200	0	-21.5	Water	Water
D-6	2200	-21.5	-27.5	Silt	ML
D-6	2200	-27.5	-30.5	Silty Sand	SM
D-6	2200	-30.5	-38	Clayey Silt	MH
D-6	2200	-38	-38.5	Silty Sand	SM
D-6	2200	-38.5	-99	TD	TD
A-10	3600	0	-19	Water	Water
A-10	3600	-19	-30	Silt	ML
A-10	3600	-30	-34	Silt	ML
A-10	3600	-34	-36.5	Sand	SP-SM
A-10	3600	-36.5	-42	Silt	ML
A-10	3600	-42	-53.5	Sand	SP
A-10	3600	-53.5	-99	TD	TD
D-7	4600	0	-18.5	Water	Water
D-7	4600	-18.5	-25.5	Silty Sand	SM
D-7	4600	-25.5	-28	Organic Silt	OH
D-7	4600	-28	-41.5	Clayey Silt	MH
D-7	4600	-41.5	-50	Sand	SP
D-7	4600	-50	-99	TD	TD
D-8	7300	0	-14.9	Water	Water
D-8	7300	-14.9	-19.4	Sand	SP
D-8	7300	-19.4	-21.4	Silt	ML
D-8	7300	-21.4	-36.9	Clay	CL
D-8	7300	-36.9	-41.9	Silty Sand	SM
D-8	7300	-41.9	-45.4	Sand	SP
D-8	7300	-45.4	-99	TD	TD
D-9	10300	0	-17	Water	Water
D-9	10300	-17	-20.5	Silt	ML
D-9	10300	-20.5	-27	Peat	Pt
D-9	10300	-27	-34	Sand	SP
D-9	10300	-34	-99	TD	TD
B-9	10800	0	-17.3	Water	Water
B-9	10800	-17.3	-18.55	Silty Sand	SM
B-9	10800	-18.55	-20.3	Silt	ML
B-9	10800	-20.3	-52.8	Silt	ML
B-9	10800	-52.8	-54.8	Sand	SP-SM
B-9	10800	-54.8	-66.8	Sandy Gravel	GP

Bore Hole	Distance along Pipeline Alignment (feet)	Top of Stratigraphic Unit (MLLW ft)	Bottom of Stratigraphic Unit (MLLW ft)	Sediment Description	USCS Designation
B-9	10800	-66.8	-99	TD	TD
D-10	12500	0	-11.2	Water	Water
D-10	12500	-11.2	-16.7	Silt	ML
D-10	12500	-16.7	-18.2	Silty Sand	SM
D-10	12500	-18.2	-21.2	Peat	Pt
D-10	12500	-21.2	-26.2	Organic Silt	OL
D-10	12500	-26.2	-99	TD	TD
D-11	13600	0	-15	Water	Water
D-11	13600	-15	-16	Silty Sand	SM
D-11	13600	-16	-24	Sand	SP-SM
D-11	13600	-24	-30.25	Silt	ML
D-11	13600	-30.25	-33	Peat	Pt
D-11	13600	-33	-34	Silt	ML
D-11	13600	-34	-35.5	Sand	SP
D-11	13600	-35.5	-99	TD	TD
B-8	14900	0	-15.5	Water	Water
B-8	14900	-15.5	-21.5	Silt	ML
B-8	14900	-21.5	-26.5	Silt	ML
B-8	14900	-26.5	-29.5	Sand	SP
B-8	14900	-29.5	-41.5	Gravelly Sand	SP-SM
B-8	14900	-41.5	-99	TD	TD
D-12	16500	0	-12.9	Water	Water
D-12	16500	-12.9	-13.9	Silty Sand	SM
D-12	16500	-13.9	-16.4	Silt	ML
D-12	16500	-16.4	-22.65	Silty Sand	SM
D-12	16500	-22.65	-28.9	Silt	ML
D-12	16500	-28.9	-44.9	Sandy Gravel	GW-GP
D-12	16500	-44.9	-99	TD	TD
B-7	18200	0	-7.1	Water	Water
B-7	18200	-7.1	-9.1	Silty Sand	SM
B-7	18200	-9.1	-22.6	Silt	ML
B-7	18200	-22.6	-24.85	Peat	Pt
B-7	18200	-24.85	-36.6	Sandy Silt	ML
B-7	18200	-36.6	-48.6	Gravelly Sand	SP
B-7	18200	-48.6	-99	TD	TD
D-13	18700	0	-7.2	Water	Water
D-13	18700	-7.2	-9.2	Sand	SP
D-13	18700	-9.2	-21.45	Silt	ML
D-13	18700	-21.45	-22.7	Peat	Pt
D-13	18700	-22.7	-25.2	Silt	ML
D-13	18700	-25.2	-99	TD	TD
D-14	20700	0	-7.2	Water	Water
D-14	20700	-7.2	-8.2	Silt	ML
D-14	20700	-8.2	-14.7	Silty Sand	SM
D-14	20700	-14.7	-17.2	Silt	ML
D-14	20700	-17.2	-29.2	Sand	SP
D-14	20700	-29.2	-37.7	Sandy Gravel	GP
D-14	20700	-37.7	-99	TD	TD

Bore Hole	Distance along Pipeline Alignment (feet)	Top of Stratigraphic Unit (MLLW ft)	Bottom of Stratigraphic Unit (MLLW ft)	Sediment Description	USCS Designation
B-6	22500	0	-6.5	Water	Water
B-6	22500	-6.5	-7.25	Silty Sand	SM
B-6	22500	-7.25	-15	Silt	ML
B-6	22500	-15	-18.5	Silt	ML
B-6	22500	-18.5	-24.5	Sand	SP-SM
B-6	22500	-24.5	-28.25	Silty Sand	SM
B-6	22500	-28.25	-43	Gravelly Sand	SP
B-6	22500	-43	-99	TD	TD
D-15	23700	0	-6	Water	Water
D-15	23700	-6	-9	Silty Sand	SM
D-15	23700	-9	-11	Silt	ML
D-15	23700	-11	-12.5	Organic Silt	OL
D-15	23700	-12.5	-18	Silty Sand	SM
D-15	23700	-18	-22.5	Gravelly Sand	SP
D-15	23700	-22.5	-99	TD	TD
B-5	24900	0	-6.7	Water	Water
B-5	24900	-6.7	-14.2	Silt	ML
B-5	24900	-14.2	-17.2	Sand	SP-SM
B-5	24900	-17.2	-33.2	Sandy Gravel	GP
B-5	24900	-33.2	-99	TD	TD
D-16	25900	0	-5.3	Water	Water
D-16	25900	-5.3	-10.3	Sandy Silt	ML
D-16	25900	-10.3	-23.3	Sand	SP-SM
D-16	25900	-23.3	-36.3	Sandy Gravel	GW
D-16	25900	-36.3	-99	TD	TD
B-4	27300	0	-5.7	Water	Water
B-4	27300	-5.7	-7.7	Silt	ML
B-4	27300	-7.7	-12.7	Silt	ML
B-4	27300	-12.7	-15.7	Sand	SP-SM
B-4	27300	-15.7	-27.7	Sandy Gravel	GP
B-4	27300	-27.7	-99	TD	TD
D-17	28000	0	-4.5	Water	Water
D-17	28000	-4.5	-9.25	Silty Sand	SM
D-17	28000	-9.25	-20.5	Gravelly Sand	SP-SM
D-17	28000	-20.5	-99	TD	TD
B-11	28400	0	-5	Water	Water
B-11	28400	-5	-13	Silt	ML
B-11	28400	-13	-15	Gravelly Sand	SP-SM
B-11	28400	-15	-99	TD	TD
B-3	29600	0	-5.6	Water	Water
B-3	29600	-5.6	-12.6	Silty Sand	SM
B-3	29600	-12.6	-15.1	Silt	ML
B-3	29600	-15.1	-17.1	Silty Sand	SM
B-3	29600	-17.1	-41.85	Sandy Gravel	GP-GM
B-3	29600	-41.85	-99	TD	TD
D-18	30100	0	-4.4	Water	Water
D-18	30100	-4.4	-18.4	Silt	ML
D-18	30100	-18.4	-34.4	Sandy Gravel	GP

Bore Hole	Distance along Pipeline Alignment (feet)	Top of Stratigraphic Unit (MLLW ft)	Bottom of Stratigraphic Unit (MLLW ft)	Sediment Description	USCS Designation
D-18	30100	-34.4	-99	TD	TD
D-19	31100	0	-4.5	Water	Water
D-19	31100	-4.5	-8	Silt	ML
D-19	31100	-8	-9.75	Silty Sand	SM
D-19	31100	-9.75	-10.25	Peat	Pt
D-19	31100	-10.25	-34	Sandy Gravel	GP
D-19	31100	-34	-99	TD	TD
D-20	31500	0	-4.2	Water	Water
D-20	31500	-4.2	-6.2	Sand	SP-SM
D-20	31500	-6.2	-8.7	Silt	ML
D-20	31500	-8.7	-14.2	Sandy Gravel	GW-GP
D-20	31500	-14.2	-33.7	Sandy Gravel	GP+GW
D-20	31500	-33.7	-99	TD	TD
D-21	31730	0	-4	Water	Water
D-21	31730	-4	-6	Sand	SP
D-21	31730	-6	-10	Silty Sand	SM
D-21	31730	-10	-43.75	Sandy Gravel	GW-GP
D-21	31730	-43.75	-99	TD	TD
B-2	31950	0	-1.5	Gravelly Sand	SP
B-2	31950	-1.5	-9.5	Sandy Gravel	GP-GM
B-2	31950	-9.5	-10.5	Silty Sand	SM
B-2	31950	-10.5	-31.25	Sandy Gravel	GW-GM
B-2	31950	-31.3	-99	TD	TD

Table 4. Applicant's Preferred Pipeline Alignment–Grain-Size Results

Bore Hole	Distance along Pipeline Alignment (feet)	Sample Depth (MLLW ft)	Silt and Clay Fraction (percent passing #200 sieve)	USCS Designation
D-5	0	-44.5	24	SM
D-5	0	-49.5	1.2	GW
D-5	0	-64.5	15	SM
D-6	2200	-26.5	66	ML
A-10	3600	-26.5	98	ML
D-7	4600	-45	3.6	SP
D-8	7300	-16.9	3.4	SP
D-9	10300	-21	45	Pt
B-9	10800	-17.8	16	SM
B-9	10800	-22.4	99	ML
D-10	12500	-13.2	73	OL
D-10	12500	-17.2	18	SM
D-11	13600	-17.5	5.7	SP-SM
D-11	13600	-21	20	SM
B-8	14900	-18	96	ML
B-8	14900	-23	61	ML
D-12	16500	-17.9	27	SM
D-12	16500	-32.9	2.8	GW
B-7	18200	-8.1	37.5	SM
B-7	18200	-9.2	92	ML
B-7	18200	-12.6	77	ML
B-7	18200	-26.9	67.5	ML
B-7	18200	-38.1	3.2	GP
D-13	18700	-7.2	3.3	SP
D-13	18700	-12.2	84	ML
D-14	20700	-11.2	12	SP-SM
D-14	20700	-31.2	4.5	GP
B-6	22500	-8.8	97	ML
B-6	22500	-16.3	92	SP
D-15	23700	-6.3	28	OL/SM
D-15	23700	-16	13	SM
B-5	24900	-11.7	85	ML
D-16	25900	-5.3	56	ML
D-16	25900	-10.3	12	SP-SM
B-4	27300	-13.7	7.4	SP-SM
B-4	27300	-15.7	1.1	GP
D-17	28000	-4.5	28	SM
D-17	28000	-9.5	11	SP-SM
D-17	28000	-13.5	1.6	SP
B-3	29600	-11.8	40	SM
D-19	31100	-9	16	SM
D-19	31100	-10.3	6.4	SP-SM
D-20	31500	-8.8	7.8	GW-GM
D-20	31500	-13.7	7.1	SP-SM

Bore Hole	Distance along Pipeline Alignment (feet)	Sample Depth (MLLW ft)	Silt and Clay Fraction (percent passing #200 sieve)	USCS Designation
D-20	31500	-18.7	2.4	GW
D-21	31730	-8	15	SM
D-21	31730	-15	6.4	GW-GM
D-21	31730	-18.5	8.9	GP-GM
D-21	31730	-20.5	9.9	GP-GM
D-21	31730	-28	8.8	GW-GM
B-2	31950	-6.3	7.7	GP-GM
B-2	31950	-11.6	24	SM
B-2	31950	-17.7	6.9	GW-GM

Source: URS Corporation. August 15, 2000. *Liberty Development: Construction Effects on the Boulder Patch - Additional Studies* . Report prepared for BP Exploration (Alaska) Inc.

Table 5. Estimated Silt and Clay Volume for Offshore Portion of Pipeline Alternatives based on Design Trench Dimensions

	Estimated Trench Volume by Stratigraphic Unit (cubic yards)	Silt and Clay Content (Percent Fines)	Estimated Volume of Silt and Clay (cubic yards)
APPLICANT'S PREFERRED PIPELINE ALIGNMENT (DESIGN TRENCH VOLUME OF 323,000 CUBIC YARDS)¹			
Silty Sand (SM)	2,445	26%	636
Silty Sand (SM-SP)	20,740	18%	3,650
Peat (Pt)	10,759	45%	4,842
Silty Sand (SM)	17,536	26%	4,559
Silty Sand (SM)	19,637	26%	5,106
Peat (Pt)	5,826	45%	2,622
Silt (ML-OL)	3,813	73%	2,783
Clay (CL)	10,328	95%	9,812
Silty Sand (SM-SP)	8,414	18%	1,515
Silt (ML)	1,002	88%	882
Silt (ML)	70,084	88%	61,674
Silt (ML)	56,850	88%	50,028
Total Excavation (cubic yards)	227,434	65%	148,107
SOUTHEAST PIPELINE ALIGNMENT (SOUTHERN ISLAND)			
Silt (ML)	177,563	89%	158,031
Silty Sand (SM)	45	26%	12
Silty Sand (SM)	13,558	26%	3,525
Gravel (GP-GW)	9,262	3%	278
Sand (SP)	34,986	2%	700
Silty Sand (SM)	3	26%	1
Total Excavation (cubic yards)	235,417	69%	162,546

Sediment quantity estimates derived from sediments in water depth greater than 6.5 feet (conservative seaward bottom fast ice edge).

Source: URS Corporation. August 15, 2000. *Liberty Development: Construction Effects on the Boulder Patch – Additional Studies*. Report prepared for BP Exploration (Alaska) Inc.

¹ Design volume as presented in Table 8-1 (page 76) of the *Liberty Development Project Development and Production Plan, Revision 2, July 31, 2000*.

Table 6. Estimated Silt and Clay Volume for Offshore Portion of Pipeline Alternatives based on Maximum Excavation Limits

	Estimated Trench Volume by Stratigraphic Unit (cubic yards)	Silt and Clay Content (Percent Fines)	Estimated Volume of Silt and Clay (cubic yards)
APPLICANT'S PREFERRED PIPELINE ALIGNMENT (BASED ON EXCAVATION LIMIT OF 724,000 CUBIC YARDS)²			
Silty Sand (SM)	5,497	26%	1,429
Silty Sand (SM-SP)	46,630	18%	8,207
Peat (Pt)	24,190	45%	10,886
Silty Sand (SM)	39,426	26%	10,251
Silty Sand (SM)	44,150	26%	11,479
Peat (Pt)	13,100	45%	5,895
Silt (ML-OL)	8,572	73%	6,258
Clay (CL)	23,220	95%	22,059
Silty Sand (SM-SP)	18,917	18%	3,405
Silt (ML)	2,253	88%	1,983
Silt (ML)	157,573	88%	138,664
Silt (ML)	127,817	88%	112,479
Total Excavation (cubic yards)	511,345	65%	332,994
SOUTHEAST PIPELINE ALIGNMENT (SOUTHERN ISLAND)			
Silt (ML)	339,220	89%	301,906
Silty Sand (SM)	101	26%	26
Silty Sand (SM)	30,482	26%	7,925
Gravel (GP-GW)	20,823	3%	625
Sand (SP)	78,660	2%	1,573
Silty Sand (SM)	7	26%	2
Total Excavation (cubic yards)	469,293	69%	312,057

Source: URS Corporation. August 15, 2000. *Liberty Development: Construction Effects on the Boulder Patch – Additional Studies*. Report prepared for BP Exploration (Alaska) Inc.

² Excavation limit volume as presented in Table 8-1 (page 76) of the *Liberty Development Project Development and Production Plan, Revision 2, July 31, 2000*.

References

- Arctic Environmental Information and Data Center (AEIDC). 1974. Alaska Regional Profiles. Vol. II. Arctic Region. University of Alaska, Anchorage, AK.
- Armstrong, Robert H. Guide to the Birds of Alaska. Seattle: Alaska Northwest Books, 1995.
- BP Exploration (Alaska) Inc.; Liberty Development Project Development and Production Plan. 1998.
- Britch, R.P., R.C. Miller, J.P. Downing, T. Petrillo, and M. Vert. 1983. Volume II physical processes. In B.J. Gallaway and R.P. Britch (eds.). Environmental Summer Studies (1982) for the Endicott Development. LGL Alaska Research Associates, Inc. and Harding Technical Services. Report for SOHIO Alaska Petroleum Company, Anchorage, Alaska. 219 pp.
- Broad, A.C. 1977. Environmental assessment of selected habitats in the Beaufort and Chukchi Sea littoral system. In: Environmental Assessment Alaskan Continental Shelf. Quarterly report. BLM/NOAA, OCSEAP. Boulder, CO.
- Broad, A.C., H. Koch, D.T. Mason, G.M. Petrie, D.E. Schneider, and R.J. Taylor. 1978. Environmental assessment of selected habitats in the Beaufort Sea littoral system. In: Environmental Assessment of the Alaskan Continental Shelf. Annual report. NOAA. Boulder, CO.
- Chin, H., M. Busdosh, G.A. Robilliard, and R.W. Firth, Jr. 1979. Environmental Studies Associated with the Prudhoe Bay Dock - Physical Oceanography and Benthic Ecology. The 1978 studies. Prepared for ARCO Oil and Gas Company by Woodward-Clyde Consultants, Anchorage, AK.
- Colonell, J.M., and A.W. Nedoroda. 1990. Appendix B. Coastal oceanography of the Alaska Beaufort Sea. Pp. B-1-B-74 in Colonell, J.M., and B.J. Gallaway (eds.). An Assessment of Marine Environmental Impacts of West Dock Causeway. Report for the Prudhoe Bay Unit Owners represented by ARCO Alaska, Inc. prepared by LGL Alaska Research Associates, Inc. and Environmental Science and Engineering, Inc. Anchorage, Alaska. 132 pp. + appendices.
- Craig, P.C. 1984. Fish use of coastal waters of the Beaufort Sea: A review. Transactions of the American Fisheries Society 113:265-282.
- Dunton, K.H. 1984. An annual carbon budget for an arctic kelp community. Pp. 311-326 in P. Barnes, D. Schell, and E. Reimnitz (eds.), The Alaska Beaufort Sea ecosystem and environment. Academic Press, Orlando.
- Dunton, K.H. 1990. Growth and production in *Laminaria solidungula*: relation to continuous underwater light levels in the Alaskan High Arctic. Marine Biology 106:297-304.
- Dunton, K.H., and S.V. Schonberg. 1981. Ecology of the Stefansson Sound kelp community: II. Results of *in situ* and benthic studies. In A.C. Broad et al., Environmental assessment of selected habitats in the Beaufort and Chukchi littoral system. Annual Report, April 1981, in Environmental Assessment of the Alaskan Continental Shelf. NOAA Environmental Research Labs., Boulder, CO. 65 pp.
- Dunton, K.H., and D.M. Schell. 1986. A seasonal carbon budget for the kelp *Laminaria solidungula* in the Alaskan High Arctic. Mar. Ecol. Prog. Ser. 31:57-66.
- Fechhelm, R.G., W.B. Griffiths, W.J. Wilson, B.A. Trimm, J.M. Colonell. 1996. The 1995 Fish and Oceanography Study, Mikkelsen Bay, Alaska. Northern Alaska Research Studies. Prepared by LGL Research Associates Inc. and Woodward-Clyde Consultants for BP Exploration (Alaska) Inc., Anchorage, Alaska.
- Feder, H.M., D.G. Shaw and A.S. Naidu. 1976. The arctic coastal environment in Alaska. Institute of Marine Science Reports R-76-7. Vol. 1-3. University of Alaska.
- Frost, K.J., L.F. Lowry, S. Hills, G. Pendleton, and D. DeMaster. 1997. Monitoring distribution and abundance of ringed seals in northern Alaska. Rep. From Alaska Dept. Of Fish and Game, Juneau, AK, to Minerals Management Service, Anchorage, AK. Final Interim Report, May 1996-March 1997. 42 pp.
- Grider, G.W., G.A. Robilliard, and R.W. Firth. 1977. Environmental studies associated with the Prudhoe Bay dock: coastal processes and marine benthos. Final Report. Prepared for Atlantic Richfield Corp. Prepared by Woodward-Clyde Consultants, Anchorage, AK.

References

- Grider, G.W., G.A. Robilliard, and R.W. Firth. 1978. Environmental studies associated with the Prudhoe Bay dock: coastal processes and marine benthos. Final Report. Prepared for Atlantic Richfield Corp. Prepared by Woodward-Clyde Consultants, Anchorage, AK.
- Harris, R.E., G.W. Miller, R.E. Elliott, and W.J. Richardson. 1997. Seals (Chapter 4, p. 42) *In* W.J. Richardson (ed.), Northstar marine mammal monitoring program, 1996: marine mammal and acoustical monitoring of a seismic program in the Alaskan Beaufort Sea. LGL Rep. 2121-2. Rep. from LGL Ltd., King City, Ont., and Greeneridge Sciences Inc., Santa Barbara, CA, for BP Explor. (Alaska) Inc., Anchorage, AK, and Nat. Mar. Fish. Serv., Anchorage, AK, and Silver Spring, MD. 245 pp.
- Johnson, S.R., and D.R. Herter. 1989. The birds of the Beaufort Sea. BP Exploration (Alaska) Inc., Anchorage, AK. 372 pp.
- Kessler, Doyne W. Alaska's Saltwater Fishes and Other Sealife. Anchorage, Alaska. Northwest Publishing Co. 1985.
- LGL Alaska Research Associates, Inc.; Applied Sociocultural Research; and Woodward-Clyde Consultants. 1998. Final Environmental Report, Liberty Development Project.
- Minerals Management Service. 1987a. Beaufort Sea sale 97 final environmental impact statement. MMS OCS EIS/EA 87-0069. U.S. Dept. of Interior, MMS, Alaska Outer Continental Shelf Region, Anchorage, AK.
- Minerals Management Service. 1987b. Chukchi Sea sale 109 final environmental impact statement. MMS OCS EIS/EA 87-0110. U.S. Dept. of Interior, MMS, Alaska Outer Continental Shelf Region, Anchorage, AK.
- Minerals Management Service. 1990. Beaufort Sea planning area oil and gas lease sale 124. Final Environmental Impact Statement. MMS OCS EIS/EA MMS 90-0063. U.S. Dept. of Interior, MMS, Alaska Outer Continental Shelf Region, Anchorage, AK.
- Minerals Management Service. 1996. Beaufort Sea planning area oil and gas lease sale 144. Final Environmental Impact Statement. MMS OCS EIS/EA MMS 96-0012. U.S. Dept. of Interior, MMS, Alaska Outer Continental Shelf Region, Anchorage, AK.
- Minerals Management Service. 1997. Beaufort Sea planning area oil and gas lease sale 170. Draft Environmental Impact Statement. MMS OCS EIS/EA MMS 97-0011. U.S. Dept. of Interior, MMS, Alaska Outer Continental Shelf Region, Anchorage, AK.
- Montgomery Watson. 1997. Liberty Island Route Water/Sediment Sampling. Prepared for BP Exploration (Alaska). April 1997.
- Montgomery Watson. 1998. Liberty Island Route Water/Sediment Sampling Revised and Corrected Final Data Report. Prepared for BP Exploration (Alaska). August 1998.
- Moore, S.E. and R.R. Reeves. 1993. Distribution and movement. Pp. 313-386 *in* J.J. Burns, J.J. Montague, and C.J. Cowles (eds.). The bowhead whale. Spec. Publ. 2. Soc. Mar. Mamm., Lawrence, KS. 787 pp.
- Morrow, James E. Illustrated Key to Freshwater Fish of Alaska. Anchorage: Alaska Northwest Publishing Co. 1974.
- Reimnitz, E., and L. Toimil. 1976. Diving notes from three Beaufort Sea sites. *In* P. Barnes and E. Reimnitz. Geologic Processes and Hazards of the Beaufort Sea Shelf and Coastal Regions. Quarterly Report, December 1976. Nat. Oceanic Atmos. Admin., Boulder, CO. Attachment J. 7 pp.
- Schell, D.M. 1982. Primary production and nutrient dynamics in Simpson Lagoon and adjacent waters. Final Report, OCSEAP, Research Unit 467.
- Small, R.J. and D.P. DeMaster. 1995. Alaska marine mammal stock assessments 1995. U.S. Dept. Commerce, NOAA Tech. Memo. NMFS-AFSC-57. 93 pp.
- Toimil, L.J., and K.H. Dunton. 1984. Summer 1983 supplemental study environmental effect of gravel island construction OCS-Y0191 (BF-37) Beechy Point, Block 480 Stefansson Sound, Alaska. Report prepared for Exxon Co., Houston, TX, by Harding Lawson Associates (HLA Job No. 9612,045.09).

References

- Tritton, D.J. 1977. *Physical Fluid Dynamics*. Van Nostrand Reinhold, Berkshire, England, U.K. 362p.
- URS Greiner Woodward Clyde. 1998. *Liberty Development Water Quality Study*. Draft report in preparation for BP Exploration (Alaska) Inc. November, 1998.
- URS Corporation. 2000. *Liberty Development: Construction Effects on the Boulder Patch – Additional Studies*. Report prepared for BP Exploration (Alaska) Inc. August 15, 2000.
- U.S. Army Corps of Engineers. 1987. 1985 Final Report for the Endicott Monitoring Program, Volume 3, Oceanographic Monitoring. Prepared by Envirosphere Company, Anchorage, AK, for the U.S. Army Corps of Engineers, Alaska District.
- U.S. Army Corps of Engineers. 1990. 1986 Final Report for the Endicott Monitoring Program, Volume 2, Oceanography. Prepared by Envirosphere Company, Anchorage, AK, for the U.S. Army Corps of Engineers, Alaska District.
- U.S. Army Corps of Engineers. 1991. 1987 Final Report for the Endicott Monitoring Program, Volume 2, Oceanography. Prepared by Science Applications International Corporation, Anchorage, AK, for the U.S. Army Corps of Engineers, Alaska District.
- U.S. Army Corps of Engineers. 1992. 1988 Final Report for the Endicott Monitoring Program, Volume 2, Oceanography. Prepared by Science Applications International Corporation, Anchorage, AK, for the U.S. Army Corps of Engineers, Alaska District.
- U.S. Army Corps of Engineers. 1993. 1989 Final Report for the Endicott Monitoring Program, Volume 2, Oceanography. Prepared by Science Applications International Corporation, Anchorage, AK, for the U.S. Army Corps of Engineers, Alaska District.
- U.S. Army Corps of Engineers. 1994. 1990 Final Report for the Endicott Monitoring Program, Volume 2, Oceanography. Prepared by Science Applications International Corporation, Anchorage, AK, for the U.S. Army Corps of Engineers, Alaska District.
- U.S. Department of the Interior, Minerals Management Service, Alaska OCS Region. *Beaufort Sea Planning Area Oil and Gas Lease Sale 144, Final Environmental Impact Statement. Volume II*.
- U.S. Environmental Protection Agency, Region 10. 1986. *Final Ocean Discharge Criteria Evaluation for the Endicott Development Project*.
- Vanoni, V.A. (ed.) 1975. *Sedimentation Engineering*. American Society of Civil Engineers, New York, NY 745p.
- Vaudrey, K. 1997. *Design Basis Ice Criteria for the Liberty Development Project (Draft)*. Prepared for BP Exploration (Alaska) Inc. March 1997.
- Watson Company, 1998. *Liberty High Resolution Geophysical Survey, Foggy Island Bay in Stefansson Sound, Alaska*. Report No. Lib-FF, Volume #1, Final Report, February, 1998.
- Woodward-Clyde. 1981. *Environmental Report for Exploration in the Beaufort Sea Federal/State Outer Continental Shelf Lease Sale. Tern Prospect*. Prepared for Shell Oil Company. September 24, 1981.
- Woodward-Clyde Consultants. 1996. *The 1995 Northstar Unit sampling program. Benthic sampling*. Final report prepared for BP Exploration (Alaska) Inc., Anchorage, AK. 35 pp.
- Woodward-Clyde Consultants. 1998. *Liberty Development Pipeline Right-of-Way Sediment Analysis*. Letter Report to BP Exploration (Alaska) Inc. June 16, 1998.
- Wynn, Kate. *Guide to Marine Mammals of Alaska*. Fairbanks: UAF. 1992.

APPENDIX I

**EIS
DOCUMENTS
PREPARED
BY OR FOR
EPA**

- I-1* **BPXA's Liberty Island Oil and Gas Development Project Fact Sheet**
- I-2 **BPXA's Liberty Island Oil and Gas Development Project NPDES Proposed Final Permit AK-005314-7 and Responses to Public Comments on the Issuance of NPDES Permit No. AD-005314-7**
- I-3* **Ocean Discharge Criteria Evaluation – in Support of the Liberty Development Project NPDES Permit Application (URS Greiner Woodward Clyde, 1998)**

BPXA's Liberty Island Oil and Gas Development Project Fact Sheet

This appendix was published as part of the Liberty Development and Production Plan (DPP) Draft Environmental Impact Statement (EIS) and was not revised for the Final EIS. The reader is referred to this appendix in the Draft EIS. This appendix is also available on the CD-ROM (MMS 2002-019 CD) and on the Internet (<http://www.mms.gov/alaska/cproject/liberty>).



Fact Sheet

Date:

NPDES Permit Number: AK-005314-7

The U.S. Environmental Protection Agency (EPA) Plans to Reissue a Wastewater Discharge Permit to:

BP Exploration (Alaska), Inc.

900 East Benson Boulevard
P.O. Box 196612
Anchorage, Alaska 99519-6612

EPA Proposes NPDES Permit Reissuance.

EPA proposes to issue a *National Pollutant Discharge Elimination System* (NPDES) permit to BP Exploration (Alaska), Inc. The proposed permit sets conditions on the discharge of pollutants from the **Liberty Island oil and gas development and production project** (the facility) off Alaska's North Slope at 70 16'45" north latitude, 147 33'29" west longitude. The Liberty Island project is a new source in the offshore subcategory of the oil and gas extraction point source category for the Outer Continental Shelf (OCS) of Foggy Island Bay, Beaufort Sea, Arctic Ocean. In order to ensure protection of water quality and human health, the permit places limits on the types and amounts of pollutants that can be discharged and places other conditions on the facility.

This Fact Sheet includes:

- the tentative determination of EPA to issue the permit,
- information on public comment, public hearing and appeal procedures,
- a description of the facility and proposed discharge,
- a map and description of the discharge location,
- a listing of past and proposed effluent limitations and other conditions, and
- technical material supporting the conditions in the permit.

EPA Invites Comments on the Proposed Permit.

EPA will consider all substantive comments before reissuing the final NPDES permit. Those wishing to comment on the proposed permit may do so in writing by the expiration date of the Public Notice. After the Public Notice expires and the public comments have been considered,

EPA Region 10's Office of Water Director will make a final decision regarding permit reissuance.

If no substantive comments are received, the tentative conditions in the proposed permit will become final and the permit will become effective upon issuance. If substantive comments are received, EPA will respond to the comments and the permit will become effective 30 days after its issuance date, unless a request for an evidentiary hearing is submitted within 30 days.

Documents Are Available for Review.

The proposed NPDES permit and related documents can be reviewed at EPA's Regional Office in Seattle between 9:00 a.m. and 4:00 p.m., Monday through Friday. To request copies and other information, contact the NPDES Permits Unit at:

United States Environmental Protection Agency, Region 10
1200 Sixth Avenue, OW-130
Seattle, Washington 98101
(206) 553-0523 or
1-800-424-4372 (from Alaska, Idaho, Oregon and Washington)

USEPA, Anchorage Operations Office
222 West 7th Ave, #19
Anchorage, Alaska 99513-7588
(907) 271-5083

USEPA, Juneau Operations Office
410 Willoughby Ave
Juneau, Alaska 99801-1795
(907) 586-7619

TABLE OF CONTENTS

	<u>page</u>
1 APPLICANT	5
2 TYPE OF FACILITY AND ACTIVITY	5
2.1 Facility Location and Description	5
2.2 Process Description	5
2.3 Permit and Application History	6
3 PROPOSED DISCHARGE	6
3.1 Nature, Amount and Composition of Discharge	6
3.2 Treatment of Wastewater Prior to Discharge	9
4 RECEIVING WATER	9
4.1 Nature of Foggy Island Bay and the Beaufort Sea	9
4.2 Description of the Biological Environment	10
4.3 Beneficial Uses of Foggy Island Bay and the Beaufort Sea	12
5 BASIS FOR EFFLUENT LIMITATIONS AND MONITORING	12
5.1 General Approach	12
5.2 Summary of Effluent Limitations	14
5.3 Technology-based Evaluation	15
5.4 Water Quality-based Evaluation	15
5.5 Summary of Effluent Monitoring	17
6 BASIS FOR BEST MANAGEMENT PRACTICES PLAN	17
7 BASIS FOR ANNUAL REPORT	18
8 PERMIT CONDITIONS FOR COMPLIANCE, RECORDING, REPORTING and OTHER GENERAL PROVISIONS	18
9 OTHER LEGAL REQUIREMENTS	19
9.1 Endangered Species Act	19
9.2 Fishery Conservation and Management Act	19
9.3 Pollution Prevention Act	20
9.4 Oil Spill Requirements	20
10 MODIFICATION OF PERMIT LIMITS OR OTHER CONDITIONS	20
11 PERMIT EXPIRATION	20
12 GLOSSARY OF TERMS AND ACRONYMS	21

13 REFERENCES 25

Figure 1: Location of BPXA's Liberty Island Project. 26

Figure 2: Diagram of BPXA's Liberty Island Project. 27

1 APPLICANT

BP Exploration (Alaska), Inc.
900 East Benson Boulevard
P.O. Box 196612
Anchorage, Alaska 99519-6612

2 TYPE OF FACILITY AND ACTIVITY

2.1 Facility Location and Description

The Liberty Island oil and gas development and production project (the facility) will develop oil and natural gas reserves beneath Foggy Island Bay in the Alaskan Beaufort Sea at 70° 16' 45" north latitude, 147° 33' 29" west longitude. The Liberty oil field is located approximately 5 miles offshore in Foggy Island Bay (Figure 1). BP Exploration (Alaska), Inc. (BPXA) plans to construct an artificial gravel island between the McClure Islands and the coast in water depths of about 22 feet (ft) on federal OCS oil and gas lease OCS-Y-1650 (Sale 144) in Foggy Island Bay. The facility will support field development drilling and hydrocarbon production. A sub-seabed pipeline will bring sales-quality oil onshore to connect with the Badami Pipeline. A detailed project description is provided in the Environmental Impact Statement (EIS) for the Liberty Development and Production Plan (MMS 2000).

2.2 Process Description

The Liberty Island oil and gas development and production project is described in detail in the following reports:

- ! EIS for the Liberty Development and Production Plan (MMS 2000),
- ! Liberty Development Project Development and Production Plan (BPXA 1998a),
- ! Ocean Discharge Criteria Evaluation in Support of the Liberty Development Project NPDES Permit Application (Woodward-Clyde 1998a),
- ! Section 103 Marine Protection, Research and Sanctuaries Act, Dredged material Disposal Site Evaluation in Support of the Liberty Development Project (Woodward-Clyde 1998b), and
- ! Liberty Development Project Environmental Report (LGL et al.1998).

The facility will be a self-contained offshore drilling and pumping operation with oil and gas processing facilities on an artificial gravel island and with two buried, bundled pipelines to: one a 12-inch oil pipeline and the other a 6-inch gas pipeline. After the construction and occupation of the artificial island, the facility will drill at least 23 wells: one disposal, 14 production, six water injection, and two gas re-injection. All drilling muds and cuttings will be injected downhole into the oil field through a disposal well; no surface discharges of muds and cuttings are planned under normal operations.

2.3 Permit and Application History

The Facility is a new source discharger proposed for construction on a to-be-completed offshore gravel island. It does not exist at this time and has no previous permit history. BPXA submitted NPDES application Form 1 and Form 2D to EPA Region 10 on March 27, 1998, in application for NPDES permit. no. AK-005314-7; the application was timely and complete.

3 PROPOSED DISCHARGE

3.1 Nature, Amount and Composition of Discharge

Proposed discharges from the facility consist of the process water system that includes continuous flush water (Discharge 001a; 21,600 gpd average), desalination unit wastes (Discharge 001b; 40,320 gpd average), temporary sanitary and domestic wastewater (Discharge 001c; 9,072 gpd average), and seawater treatment plant (STP) filter backwash (Discharge 001d; 22,118 gpd average). The facility will discharge fire suppression system test water on an intermittent basis (Discharge 002; typically no discharge). Deck drainage sumps are proposed in the island design (Discharges 003, 004 and 005) and the water collected in the sumps will be injected into the island's disposal well; discharge from the sumps to the marine environment will only occur in the event of an upset condition (i.e., 100 year storm event). During construction of the island the facility will discharge a return flow of construction dewatering (sea-seepage) out of the gravel-filled construction area back into the sea (Discharge 006; 1,000,000 gpd average).

! Facility Process Water Discharge – Outfall 001. Four waste streams will be commingled, dechlorinated and discharged through marine Outfall 001: Continuous Flush System, Potable Water Desalination System brine blowdown, Sanitary and Domestic Wastewater, and Seawater Treatment Plant backwash, Sodium metabisulfite will be injected into the commingled stream to reduce total residual chlorine (TRC) concentrations to levels that meet the State of Alaska water quality standard for TRC.

Continuous Flush System Effluent – Discharge **001a**. The Liberty Island engineering design requires a continuous flush of seawater to flow through the process system lines to prevent freezing. Chlorine in the form of calcium hypochlorite will be introduced into the process water system to reduce the biofouling of equipment. It is estimated that the low levels of TRC will be consumed in the water drawn through the Continuous Flush System. Prior to ocean discharge, this effluent will be commingled and dechlorinated with the other process water waste streams. The temperature increase attributed to heat transfer from process water equipment (e.g., pumps, piping, etc.) is nominal for the Continuous Flush System, Discharge 001a. The effluent pH will vary slightly from ambient conditions as a result of the chlorination/ dechlorination process; however, the pH is expected to be within 0.1 pH units of ambient levels.

Desalination Unit Wastes – Discharge **001b**. The potable water desalination unit will continuously create distilled water, resulting in a brine effluent with a dissolved solids concentration at twice the ambient water concentration, regardless of the rate. The

desalination unit uses thermal vapor compression technology to generate water suitable for human consumption. Seawater is boiled inside a bank of enhanced surface tubes located on one side of the heat transfer surface. The excess feed water that does not evaporate (blowdown) contains concentrated dissolved solids and salts (brine) which are nearly twice the concentration of ambient seawater. Continuous injection of maintenance chemicals including scale control additives and foamer, at concentrations which have been determined to be safe for drinking water, will be added to the feed line prior to desalination. Chlorine gas that enters the desalination unit will be off-gassed and vented into the atmosphere due to the heat and pressure of the process; it's expected that the desalination brine will not contain TRC.

The engineering specifications provided by the manufacturer indicate the effluent will have a temperature increase of 5°C to 7°C over ambient conditions. The manufacturer determined that total dissolved solids (TDS) would increase to 65 to 70‰ for ambient seawater containing 36‰. It is expected that the desalination brine will have salinity between 60‰ and 65‰.

Sanitary and Domestic Wastewater – Discharge 001c. All domestic and sanitary waste will pass through the wastewater treatment system. Secondary treatment of the domestic sewage will be accomplished using a D-series FAST System (Fixed Activated Sludge Treatment). A disinfectant system using ultraviolet (UV) light will be placed in the discharge stream between secondary treatment and final disposal. The standard discharge procedure for the facility will be to inject sanitary and domestic wastewater into a subsurface disposal well. However, during facility construction and periods when the injection well is not available, the wastewater treatment plant effluent will be commingled with the seawater treatment plant backwash, continuous flush and potable water desalination waste streams for discharge through Outfall 001. The resulting commingled stream will be dechlorinated.

Sludge resulting from the secondary treatment will be injected into the on-site subsurface disposal well. In the event that the injection well is not available, the sludge will be disposed of onshore at an approved facility within the Prudhoe Bay area.

Seawater Treatment Plant Filter Backwash – Discharge 001d. Backwash from the strainer and hydrocyclone will have an elevated concentration of total suspended solids (TSS) that will be directly dependent upon the TSS concentrations at the seawater intake. The flow will be commingled with the continuous flush effluent, potable water desalination brine, and any temporary discharge of sanitary and domestic wastewater to Outfall 001. This waste stream will be discharged through the outfall after passing through the dechlorination process.

Heat will be added to the remaining seawater, some of which will be routed to the seawater intake as required to prevent ice formation. The remaining process seawater will be deaerated. Biocide, anti-foam agent, scale inhibitor and corrosion inhibitor will be added to this fluid stream which will then be routed to the enhanced oil recover wells for injection. Since the biocide, antifoam agent and scale and corrosion inhibitors are added

downstream of the backwash flow, these additives will be injected through the disposal well into the geologic formation along with the seawater and will not be discharged into the marine environment.

Natural variability of ambient TSS determines variability of the TSS discharge. In the summer when TSS is high, the TSS discharges will be high; and in winter when the TSS is low, the TSS discharge will also be low. Summer seawater treatment plant backwash is expected to have average daily TSS concentrations of 4,600 milligrams per liter (mg/L) with maximum concentrations of 28,000 mg/L. Average daily concentrations in the winter are expected to be 780 mg/L, with maximum levels of 1,600 mg/L.

! Fire Control System Test Water – Outfall 002. The fire control system will provide emergency seawater supply throughout the Facility to suppress and extinguish fires on an as-needed basis. This system is designed to pump up to 2,500 gpm of seawater through a header and distribution system to sprinklers, hydrants, monitors and deluge valves. Fresh potable water will be supplied to maintain water pressure in the header and distribution lines, producing minor dilutions in total dissolved solids within the test water. Weekly tests of the fire control pumps will circulate untreated seawater from the seawater intake sump through the pumps and directly back in the seawater intake sump.

! Deck Drainage – Outfalls 003, 004 and 005. The Facility will employ state-of-the-practice engineering controls to monitor, control and dispose of deck drainage waters without discharging these fluids into the surrounding marine environment. The facility will incorporate best management practices (BMPs) to help prevent spills and leaks from entering the deck drainage collection system.

In the event of a petroleum or chemical spill at the Facility, all fluids collected in the deck drainage sumps will be evaluated for disposal and pumped either to the injection well or to a designated storage area pending shipment to an approved hazardous waste disposal facility.

In the event of a large flow of stormwater runoff (upset condition), such as that caused by heavy rains or by waves overtopping the island during a severe storm, the sumps will not have adequate capacity to collect, store for inspection, and be pumped to the injection well or holding tank on a batch-basis. In these cases, the sumps will overflow into the ocean. Underflow baffles are designed to retain and contain any floating oil in each sump.

! Construction Dewatering – Outfall 006. Water discharged during construction dewatering will consist of Beaufort Sea water that has percolated through the clean gravel fill and has collected in the site excavation and casing. Clean gravel fill used to construct the island will contain fine sediments which will be subsequently discharged with the excavation and casing water. A pump rated at no greater than 650 gallons per minute (gpm) will be used as required to dewater the construction trenches and pipeline caisson. The discharge hose will be placed into water adjacent to the island (and under the ice if present) .

3.2 Treatment of Wastewater Prior to Discharge

Treatment of the wastewaters consists of the (1) dechlorination of combined Discharge 001 on an as-needed basis and (2) secondary treatment and ultraviolet irradiation of the WWTP's Discharge 001c to this combined effluent. The fire control test water (Discharge 002),

deck drainage sumps (Discharges 003, 004 and 005) and the construction dewatering (Discharge 006) aren't treated for pollutant control prior to discharge because the only additions to these wastewaters are low levels of heat and fresh water.

4 RECEIVING WATER

4.1 Nature of Foggy Island Bay and the Beaufort Sea

Within Foggy Island Bay, the relatively shallow shelf depths act as a mixing zone for the clearer, generally colder and more saline ocean waters to interact with the more turbid, sediment-bearing, fresher inflows from the Sagavanirktok, Kadleroshilik and Shaviovik rivers.

During the summer open-water season, the timing and rate of discharges from the Sagavanirktok, Kadleroshilik and Shaviovik rivers determine the amount of freshwater available for distribution in the marine environment of Foggy Island Bay. The first open water typically occurs in late June to early July and, as warming continues into summer, the sea ice melts, resulting in about 75 days of open-water. After sea ice breakup, wind speed and direction become the key factors in determining the fate of freshwater advected along the coast. Wind speed and direction also influence water level variations that, in turn, play a key role in the exchange rates between brackish nearshore and offshore marine waters.

Wind history (speed and direction) is of prime importance in determining the fate of freshwater advected along the coast by currents during the open-water season. The prevailing summer winds along the Beaufort Sea coast are from the east, so the nearshore currents respond to this wind stress by flowing westward. This current regime transports river discharges westward alongshore such that freshwater is mixed with the ambient nearshore waters.

During winter, the Beaufort Sea is covered by sea ice that begins to form in late September. Freeze-up of the waters is completed by the end of October, with ice growing to a maximum thickness of 2.3 m (7.5 ft) by April (MMS 1996). Ice cover persists on average for 290 days until spring warming results in river breakup and subsequent sea ice melting near the river and stream deltas. Temperature and salinity profiles collected under the sea ice within the Beaufort Sea exhibit uniform cold, 29°F (-1.5°C), saline (32.4‰) marine waters (Montgomery Watson 1997, 1998). Under ice observations in the Beaufort Sea indicate very low current speeds aligned with bathymetry, which results in an easterly or westerly flow. The average current speed observed during ice-covered conditions is less than 0.04 kt (2 cm/s) (Montgomery Watson 1997).

In February 1997 and March 1998, Montgomery Watson collected salinity and temperature measurements under the ice in the vicinity of the proposed pipeline route for the Facility. Under-ice water temperatures ranged from 4° to 0°C (28° to 32°F), with salinity ranging from 21 to 33 ‰. Ice thickness at the stations ranged from 3 to 5.3 ft (1.0 to 1.6 m), with total ice-free water depths of 0.3 to 17 ft (0.1 to 5.1 m) (Montgomery Watson 1997, 1998).

4.2 Description of the Biological Environment

Important biological features in the proposed Liberty Island area are discussed in the following sections. Sections 4.6 through 4.11 of the *Liberty Development Environmental*

Report (LGL et al. 1998) describe in detail the biological characteristics of the area. This source, along with the *Environmental Impact Statement (EIS) for the Liberty Development and Production Plan* (MMS 1998), provided the majority of the information summarized below.

Of the seven biological resource categories listed in the EIS for the Liberty Development and Production Plan, the following have the potential to be affected by permitted discharges from Liberty Island:

- ! Seals and polar bears,
- ! Marine and coastal birds,
- ! Lower trophic organisms (including plankton and boulder patch community members)
- ! Fishes, and
- ! Threatened and Endangered Species (specifically, the bowhead whale).

These five categories are briefly described below and are described in detail in the documents referenced above.

! **Seals and Polar Bears.** The “ice seals” (ringed, bearded and spotted seals) are usually observed in open-water areas during summer and early autumn. A few ringed and bearded seals were seen near the project area during the MMS aerial surveys. Spotted seals were not identified during these surveys (Frost et al. 1997). Boat-based marine mammal monitoring conducted from July 25 to September 18, 1996, in an area near and to the west of the proposed Facility, documented the presence of all three species of seals, with 92 percent ringed seals, 7 percent bearded seals, and 1 percent spotted seals (Harris et al. 1997). Site-specific BPXA-sponsored aerial surveys for ringed seals were initiated around Liberty Island in May/June 1997. These surveys, over landfast ice, found ringed seals widely distributed throughout the Liberty area, but no other seal species were encountered (LGL et al. 1998).

Polar bears are normally associated with the pack ice that is well offshore of the project area. Denning female bears, females with cubs, and subadult males may come ashore. Female bears with young cubs hunt in fast-ice areas. Most female polar bears den on pack ice, but five den sites on land have been identified within the onshore project area (LGL et al. 1998). Polar bears may be near the Facility at any time, although the animals are most likely to occur near the coast in the fall.

! **Marine and Coastal Birds.** An estimated 10 million individual birds representing over 120 species use the Beaufort Sea area from Point Barrow, Alaska to Victoria Island, NWT, Canada (Johnson and Herter 1989). Descriptions of marine and coastal birds in the Alaskan Beaufort Sea area have been presented in the Liberty Development Environmental Report (LGL et al. 1998) and the EIS for the Liberty Development and Production Plan (MMS 1998). Nearly all species are migratory, occurring in the Arctic from May through September. The most abundant marine and coastal birds in the Foggy Island Bay and the Facility areas include oldsquaw, glaucous gull, common eider, snow goose, red phalaropes, red-necked phalaropes, semipalmated sandpiper, dunlin and stilt sandpiper.

! **Lower Trophic Organisms.** Due to the low level of primary productivity in the Alaskan Beaufort Sea, plankton communities of this area are impoverished and are characterized by low diversity, low biomass and slow growth.

Areas in Stefansson Sound with dense rock cover (more than 25 percent rock cover) are known to contain a rich epilithic flora and fauna, including extensive kelp beds (Reimnitz and Toimil 1976). Isolated patches of marine life also occur in areas where the rocks are more widely scattered (10 to 25 percent rock cover). These areas of Stefansson Sound containing rocky substrate have been charted and are designated as the "Boulder Patch."

The boulders and attached dominant kelp species, *Laminaria solidungula*, provide habitat for a large number of invertebrate species. Sponges and cnidarians are the most conspicuous invertebrates. Photosynthesis is limited to a short period during the year when light is available and ice cover has receded. During this time, *Laminaria* stores food reserves until the winter and early spring when nutrients are available to support growth.

! Fish. The nearshore zone serves as a movement corridor for fishes that are intolerant of more marine conditions and as feeding habitat for both anadromous and marine fishes (Craig 1984). Arctic and least cisco, Arctic cod, dolly varden and fourhorn sculpin comprise 90 percent of the fish caught in nearshore Beaufort sea areas. The fish enter the nearshore waters at the start of breakup (early June) to feed during the summer. During open-water periods, anadromous fish are concentrated in the nearshore zone. The fish then return to low salinity water in deep channels of rivers and deltas to overwinter.

Marine species may be found in and adjacent to nearshore waters, including primarily Arctic cod, saffron cod, fourhorn sculpin, Arctic flounder and rainbow smelt (LGL et al. 1998). Arctic cod are the most dominant species in the Arctic Ocean and are the most abundant fish collected in the Prudhoe Bay region.

! Threatened and Endangered Species. Western Arctic bowhead whales winter in the central and western Bering Sea, summer in the Canadian Beaufort Sea, and migrate around Alaska in spring and autumn (Moore and Reeves 1993). Spring migration through the western Beaufort Sea occurs through offshore ice leads, generally from mid-April to mid-June. The migration corridor is located very far offshore of the Facility area; however, a few bowheads have been observed in lagoon entrances and shoreward of the barrier islands during MMS and LGL surveys (LGL et al. 1998). Autumn migration of bowheads into Alaskan waters occurs primarily during September and October. During fall migration, most of the bowheads sighted migrate in water ranging from 65- to 165-ft deep. These migration corridors are outside of the immediate discharge area. When passing the development area, most bowheads are in depths greater than 65 ft, but a few occur closer to shore in some years (LGL et al. 1998).

In addition to the bowhead whale, there are three threatened or endangered bird species which may occur near the Facility area, but outside of the effects of the effluent discharge. The spectacled eider (*Somateria fischeri*) is the only endangered or threatened bird likely to occur regularly in the study area. The Alaska-breeding population of the Steller's eider (*Polysticta stelleri*) was listed as threatened on 11 July 1997 by the U.S. Fish and Wildlife Service (62 *Federal Register* 31748); this species may occur in very low numbers in the Prudhoe Bay area and may occur occasionally in the project area. The Arctic peregrine falcon (*Falco peregrinus tundrius*) had been listed as threatened, but the U.S. Fish and Wildlife Service removed it from the list on 5 October 1994 (59 *Federal Register* 50796). The Eskimo curlew, although historically present, is now considered to be extirpated from the area.

None of these species are expected to incur any effects outside of a zone of initial dilution of 100 feet radius around the points of discharge of Outfalls 001 and 006. Within this 1.4 acre

(62,832 sq. ft.) zone of dilution increased loads of sediments and other total suspended solids may change the composition of but will not eliminate the neritic communities in the water column and the seafloor. The mixing zone area occupies less than 0.000000001 percent of the available habitat of this nature in the shallow coastal Beaufort Sea. This permit action is not likely to adversely effect any of the above-species listed as threatened or endangered under the Endangered Species Act.

4.3 Beneficial Uses of Foggy Island Bay and the Beaufort Sea

The Beaufort Sea is classified by the Alaska Water Quality Standards as Classes II A(i)(ii)(iii), B(i)(ii), C and D for use in aquaculture, seafood processing and industrial water supply, water contact and secondary recreation, growth and propagation of fish, shellfish, aquatic life and wildlife, and harvesting for consumption of raw mollusks or other raw aquatic life.

5 BASIS FOR EFFLUENT LIMITATIONS AND MONITORING

5.1 General Approach

EPA followed the Clean Water Act, state regulations, and EPA's 1991 *Technical Support Document for Water Quality-Based Toxics Control* to develop the proposed effluent limits. In general, the Clean Water Act requires that the effluent limit for a particular pollutant be the more stringent of either the *technology-based limit* or the *water quality-based limit*. This proposed permit includes both technology-based and water quality-based limits. Technology-based limits are established based upon the level of treatment that is achievable using available technology. Water quality-based limits are designed to prevent exceedance of the Alaska water quality standards (AWQS) in the receiving water.

EPA proposes to authorize the applicant, BP Exploration (Alaska), Inc., to discharge wastewaters of Discharges 001, 001a, 001b, 001c, 001d, 002, 003, 004, 005 and 006 to the receiving water of Foggy Island Bay, Beaufort Sea. Limits and/or monitoring are proposed for Discharges 001, 001c and 006. No limits or monitoring are proposed for Discharges 001a, 001b and 001d, all of which are commingled prior to discharge and limited and monitored as Discharge 001. No limits are proposed for either the intermittent testing of the fire-control water system (002) or the intermittent stormwater discharges (003, 004 and 005).

5.2 Summary of Effluent Limitations

Table 1. Limits and Monitoring for Discharges 001, 001c and 006				
Parameter	Average Monthly Limit	Maximum Daily Limit	Sampling Method and Frequency	Reported Values
Combined wastewater, Discharge 001				
Flow, 001	0.1 MGD	0.2 MGD	Continuous recording, daily	Average monthly and maximum daily, MGD
TRC, 001	10 ug/L	20 ug/L	Grab, daily	Average monthly and maximum daily, ug/L
Temperature, 001	no limit	no more than 10 C above or below ambient	Recording or meter for effluent and ambient, daily	Average monthly and maximum daily difference of effluent minus ambient, C
Sewage plant, Discharge 001c				
Flow, 001c	10,000 gal/day	20,000 gal/day	Recording or meter, daily*	Average monthly and maximum daily*, MGD
TSS, 001c	30 mg/L; at least 85% removal	60 mg/L	Grab, weekly*	Average monthly and maximum daily*, mg/L; percent removal
BOD5, 001c	30 mg/L; at least 85% removal	60 mg/L	Grab, weekly*	Average monthly and maximum daily*, mg/L; percent removal
Fecal coliform bacteria, 001c	200 FC/100 ml	400 FC/100 ml	Grab, weekly*	Average monthly and maximum daily*, FC/100 ml
TRC, 001c	0.1 mg/L	0.2 mg/L	Grab, daily*	Average monthly and maximum daily*, mg/L
pH, 001c	no limit	no more than 8.5, no less than 6.5	Grab or meter, daily*	Minimum and maximum monthly values*, pH units
Construction dewatering, Discharge 006				
Flow, 006	no limit	no limit	Calculation or meter, daily*	Average monthly and maximum daily*, MGD
Oily sheen, 006	no visible sheen in effluent prior to discharge		Visual, hourly*	Time and date of the presence of a visible sheen; corrective action

Note: * Monitoring and reporting are required during periods of surface discharge only.

The proposed permit prohibits pollutant discharges that are not part of the normal operation of the facility as reported in the permit application in concentrations which violate Alaska Water Quality Standards.

The Permit limits all discharges from the facility as follows:

- ! The permittee shall not discharge any pollutant other than those listed in its application in concentrations which exceed applicable State water quality criteria at the end of the discharge pipe;
- ! There shall be no discharge of toxic and other deleterious substances;
- ! There shall be no discharge of floating solids or visible foam in other than trace amounts;
- ! The discharge of surfactants, dispersants and detergents shall be minimized; and
- ! Sludge removed from the treatment systems during cleaning of the treatment units shall not be reintroduced into the treatment system or discharged to waters of the United States.

5.3 Technology-based Evaluation

Section 301 of the Clean Water Act requires particular categories of industrial dischargers to meet technology-based effluent limitation guidelines. The intent of a technology-based effluent limitation is to require a minimum level of treatment for industrial and municipal *point sources* across the country based on currently available treatment technologies while allowing a discharger to choose and use any available pollution control technique to meet the limitations. Where EPA has not yet developed guidelines for a particular industry, EPA can establish permit limitations using Best Professional Judgment (BPJ; 40 CFR §§ 122.43, 122.44 and 125.3).

The permittee will provide secondary treatment for sanitary wastewater. EPA has established technology-based limits for the facility's sanitary wastewater (Discharge 001C) in this and other past permits based upon its best professional judgment that industrial sewage on the North Slope should and can be treated at a level comparable to municipal sewage. Sewage and other sanitary wastewater must receive secondary treatment for municipal facilities; secondary treatment uses filtration and biological treatment to control pollutant discharges. Part 133 of Title 40 of the Federal Code of Regulations requires that sanitary waste water be limited as follows: (1) the monthly averages of total suspended solids (TSS) and five-day biochemical oxygen demand (BOD5) shall not exceed 30 mg/L, the weekly averages for TSS and BOD5 shall not exceed 45 mg/L, and the percent removal of each during treatment shall be greater than 85% and (2) the pH of the effluent shall not be less than 6.0 nor greater than 9.0.

EPA has not established national effluent guidelines for waterflood systems.

5.4 Water Quality-based Evaluation

EPA has determined to use the Alaska Water Quality Standards to protect the water quality and beneficial uses of these coastal waters off Alaskan shores. Permit limits will be stringent enough to ensure that State water quality standards are met.

The most stringent State criteria for each pollutant regulated under the State's water quality standards is utilized in determining water quality-based limits within this NPDES permit. Temperature, pH, turbidity, sediment, residues, fecal coliform bacteria, total residual chlorine (TRC) and coagulants are potential pollutant discharges at the facility.

It is EPA's best professional judgment that the Alaska water quality criteria will be met outside of the 100 ft mixing zone of initial dilution around Outfalls 001 and 006. Dilution around Outfall 001 will generally exceed 1,000:1 and should always exceed 100:1; dilution around outfall 006 will generally exceed 100:1 and should always exceed 10:1.

Antidegradation of Water Quality. In proposing to reissue this permit, EPA has considered the State's antidegradation policy [18 AAC 70.015]. This policy states, in part, that in Alaska: "the existing water uses and the level of water quality necessary to protect the existing uses must be maintained and protected (and), if the quality of a water exceeds levels necessary to support propagation of fish, shellfish and wildlife and recreation in and on the water, that quality must be maintained and protected unless the department (ADEC)... allows the reduction in water quality...". The limits in the draft permit are consistent with and protective of the State water quality standards and the water quality of the receiving water. The draft permit is consistent with the State's antidegradation policy.

5.5 Summary of Effluent Monitoring

The Clean Water Act requires that monitoring shall be included in permits to determine compliance with effluent limitations. Monitoring may also be required to gather data for future effluent limitations or to monitor effluent impacts on the receiving water. The permittee will be responsible for conducting the monitoring and for reporting the results to EPA. Table I presents the proposed monitoring requirements based on the minimum sampling necessary to adequately monitor the facility's performance.

The proposed permit requires sampling whenever a bypass, spill, or non-routine discharge of pollutants occurs, if such a discharge could cause a violation of an effluent limit.

6 BASIS FOR BEST MANAGEMENT PRACTICES PLAN

The Clean Water Act and federal regulations authorize EPA to require *best management practices*, or BMPs, in NPDES permits. BMPs are measures for controlling the generation of pollutants and their release to waterways. For many facilities, these measures are typically included in the facility Operation & Maintenance plans (O&M) plans. BMPs are important tools for waste minimization and pollution prevention. EPA encourages facilities to incorporate BMPs into their O&M plans and to revise them as new practices are developed. The permittee has promoted its control of pollutant discharges through the use of BMP plans in the other similar facilities on Alaska's North Slope and will extend these practices to the Facility. The dechlorination of Discharge 001 and the underground injection of Discharge 001c are two wastewater treatment and management practices proposed for implementation by the permittee. The proposed permit requires the permittee to develop and implement BMP plan at the facility.

7 BASIS FOR ANNUAL REPORT

The proposed permit requires the permittee to complete and submit an annual report which compiles effluent monitoring data and reports permit violations, upset conditions, by-pass conditions, plant or process changes, and corrective actions undertaken to improve wastewater treatment and pollution prevention at the facility. The annual report provides a comprehensive record of wastewater discharge at the facility and supports improved understanding and management of the discharges and discussion of these discharges by the permittee and government representatives. Title 40 of the Code of Federal Regulations provides the regulatory basis for this requirement at sections 122.41 ("Conditions applicable to all permits"), 122.44(i) ("Monitoring requirements"), and 122.48 ("Requirements for recording and reporting of monitoring results").

8 PERMIT CONDITIONS FOR COMPLIANCE, RECORDING, REPORTING and OTHER GENERAL PROVISIONS

Sections § VI through VIII of the draft permit contain standard regulatory language that is required to be in all NPDES permits. The following sections of the permit are based largely upon 40 CFR Part 122, subpart C, "Permit Conditions" and on other referenced laws and regulations.

- Duty to Comply from 40 CFR § 122.41(a),
- Proper Operation and Maintenance from 40 CFR § 122.41(e),
- Duty to Mitigate from 40 CFR § 122.41(d),
- Toxic Pollutants from 40 CFR § 122.41(a)(1-2), § 122.44(b, e) and § 125.3,
- Removed Substances from 40 CFR § 122.41(a)(1) and (o) and CWA § 405(A),
- Need to Halt or Reduce Activity not a Defense from 40 CFR § 122.41(c),
- *Bypass* of Wastewater Treatment from 40 CFR § 122.41(m),
- *Upset* Conditions from 40 CFR § 122.41(n),
- Inspection and Entry from 40 CFR § 122.41(i),
- Penalties for Violations of Permit Conditions from 40 CFR § 122.41(a)(2-3),
- Duty to Provide Information from 40 CFR § 122.41(h),
- Records Contents from 40 CFR § 122.41(j)(3),
- Submittal of Reports from 40 CFR § 122.41(h, j and l),
- Retention of Records and Reports from 40 CFR § 122.41(j)(2),
- On-site Availability of Records and Reports from 40 CFR § 122.41(i)(2),
- Availability of Reports for Public Review from 40 CFR § 122.1(e) and § 122.7(1) and 40 CFR § 2.101,
- Planned Changes from 40 CFR § 122.41(l)(1),
- Changes in the Discharge of Toxic Substances from 40 CFR § 122.42(a),
- Anticipated Noncompliance from 40 CFR § 122.41(l)(2),
- Reporting of Noncompliance from 40 CFR § 122.41(l)(6-7) and § 122.44(g),
- Permit Actions from 40 CFR § 122.44(c) and 40 CFR § 122.61 - § 122.64,
- Duty to Reapply from 40 CFR § 122.41(b),
- Incorrect Information and Omissions from 40 CFR § 122.41(l)(8),
- Signatory Requirements from 40 CFR § 122.41(k),

- Property Rights from 40 CFR § 122.41(g),
- Severability from 40 CFR § 124.16,
- Transfers from 40 CFR § 122.41(l)(3),
- Oil and Hazardous Substance Liability from 40 CFR § 125.3, 40 CFR part 300, 33 CFR § 153.10(e) and section 311 of the Act,
- State Laws from 40 CFR § 122.1(f) and section 510 of the Act, and
- Reopening of the Permit from 40 CFR § 122.41(f) and § 122.44(c).

9 OTHER LEGAL REQUIREMENTS

9.1 Endangered Species Act

Pursuant to 40 CFR § 122.49(c), EPA has concluded that the localized effluent discharges authorized by this permit will have no effect on the continued existence of any endangered or threatened species and will not adversely affect their critical habitat; these local effects will be contained within an area of 1.4 acres and will consist of sediment-laden seawater of natural and local origins and trace levels of fecal coliform bacteria. Endangered species found in the vicinity of the project include the bowhead whale. Threatened species include the Steller's and spectacled eiders.

The draft permit, fact sheet and consistency determination will be submitted to the U.S. Fish and Wildlife Service (USFWS) and the National Marine Fisheries Service (NMFS) for review at the time of public notice. EPA is requesting USFWS and NMFS review of the draft permit and will consider their comments in the final permit decision.

EPA is requesting concurrence from USFWS and NMFS on its determination of "no effect" on these three threatened and endangered species. EPA will initiate consultation should new information reveal impacts not previously considered, should the activities be modified in a manner beyond the scope of the original opinion, or should the activities affect a newly listed threatened or endangered species.

9.2 Fishery Conservation and Management Act

The Magnuson-Stevens Fishery Conservation and Management Act requires EPA to consult with NMFS with respect to the issuance of this NPDES permit concerning its impacts on any essential fish habitat and to provide a description of the measures proposed to avoid, mitigate and offset the impact of this permitted discharge on such habitat. EPA finds that the permitted discharge will protect Alaska Water Quality Standards outside of the 100 ft mixing zone of initial dilution and that issuance of this permit is not likely to adversely affect any Arctic char, Arctic cisco, or other species which may occur vicinity of the discharge. EPA provides this fact sheet to describe the discharge, the draft permit, and the permit's limits, conditions and measures of mitigation.

9.3 Pollution Prevention Act

It is national policy that, whenever feasible, pollution should be prevented or reduced at the source, that pollution which cannot be prevented should be recycled in an environmentally safe manner and that disposal or release into the environment should be employed only as a last resort and should be conducted in an environmentally safe manner. The permittee will dispose of wastewater discharges at the facility in accordance with best management practices which will address the provisions of the Pollution Prevention Act.

9.4 Oil Spill Requirements

Section 311 of the Clean Water Act prohibits the discharge of oil and hazardous materials in harmful quantities. Discharges specifically controlled by the draft permit are excluded from the provisions of Section 311 because these discharges are limited to amounts and concentrations which are deemed to be protective of State water quality standards. However, this permit does not preclude the institution of legal action or relieve the permittee from any responsibilities, liabilities, or penalties for other unauthorized discharges of toxic pollutants which are covered by Section 311 of the Act.

10 MODIFICATION OF PERMIT LIMITS OR OTHER CONDITIONS

When EPA receives information that demonstrates the existence of reasonable cause to modify the permit in accordance with 40 CFR § 122.62(a), EPA may modify the permit. "Reasonable cause" includes alterations or additions to the facility or activity, new federal regulations or standards, new state water quality standards, the completion or modification of total maximum daily loads or wasteload allocations for the receiving water of the facility (also, see 40 CFR § 122.44(d)((1)(vii)(B)), failure of the permit to protect state water quality standards, a change in a permittee's qualification for net limits, any relevant compliance schedule, the need to incorporate or revise a pretreatment or land application plan, when pollutants which are not limited in the permit exceed the level which can be achieved by technology-based treatment, the correction of technical mistakes and legal misinterpretations of law made in determining permit conditions, and the receipt of new information relevant to the determination of permit conditions. Minor modifications to a permit may be made by EPA with the consent of a permittee in order to correct typographical errors, change an interim compliance schedule, allow for a change in ownership, change a construction schedule, or delete an outfall. Pursuant to 40 CFR § 122.63, such minor modifications may be made without public notice and review.

11 PERMIT EXPIRATION

This permit will expire five years from its effective date. In accordance with 40 CFR § 122.6(a), the conditions of an expired permit continue in force under 5 U.S.C. § 558(c) until the effective date of a new permit when a permittee submits an application for permit reissuance 180 days before the expiration of the permit. Permits which are continued because EPA has not reissued a new permit remain fully effective and enforceable.

12 GLOSSARY OF TERMS AND ACRONYMS

§ means section or subsection.

AAC means Alaska Administrative Code.

ADEC means Alaska Department of Environmental Conservation.

Average monthly discharge means the average of "daily discharges" over a monitoring month, calculated as the sum of all daily discharges measured during a monitoring month divided by the number of daily discharges measured during that month. It may also be referred to as the "monthly average discharge."

Best management practices ("BMPs") means schedules of activities, prohibitions of practices, maintenance procedures and other management practices to prevent or reduce the pollution of "waters of the United States." BMPs also include treatment requirements, operating procedures and practices to control plant site runoff, spillage or leaks, sludge or waste disposal, or drainage from raw material storage.

BOD5 means five-day biochemical oxygen demand.

Bypass means the intentional diversion of waste streams from any portion of a treatment facility.

* C means degrees Celsius.

CFR means Code of Federal Regulations.

CWA means the Clean Water Act, (formerly referred to as the Federal Water Pollution Control Act or Federal Water Pollution Control Act Amendments of 1972) Public Law 92-500, as amended by Public Law 95-217, Public Law 95-576, Public Law 96-483 and Public Law 97-117, 33 U.S.C. 1251 et seq.

Daily discharge means the discharge of a pollutant measured during a calendar day or any 24-hour period that reasonably represents the calendar day for purposes of sampling. For pollutants with limitations expressed in units of mass, the "daily discharge" is calculated as the total mass of the pollutant discharged over the day. For pollutants with limitations expressed in other units of measurement, the "daily discharge" is calculated as the average measurement of the pollutant over the day.

Daily maximum discharge means the highest allowable "daily discharge" and is also referred to as the "maximum daily discharge."

Discharge of a pollutant means any addition of any "pollutant" or combination of pollutants to "waters of the United States" from any "point source" or any addition of any pollutant or combination of pollutants to the waters of the "contiguous zone" or the ocean

from any point source other than a vessel or other floating craft which is being used as a means of transportation.

Discharge Monitoring Report (“DMR”) means the EPA uniform national form, including any subsequent additions, revisions, or modifications for the reporting of self-monitoring results by permittees. DMRs must be used by “approved States” as well as by EPA.

Effluent limitation means any restriction imposed by the Director on quantities, discharge rates, and concentrations of “pollutants” which are “discharged” from “point sources” into “waters of the United States,” the waters of the “contiguous zone,” or the ocean.

EOA means Eastern Operations Area.

EPA means U.S. Environmental Protection Agency.

ESA means the Endangered Species Act.

Facility or activity means any NPDES “point source” or any other facility or activity (including land or appurtenances thereto) that is subject to regulation under the NPDES program.

lb means pound.

Maximum means the highest measured discharge or pollutant in a waste stream during the time period of interest.

Maximum daily discharge limitation means the highest allowable “daily discharge.”

MGD means million gallons per day.

mg/L means milligrams per liter.

Mixing zone means the zone of dilution authorized by the Alaska Department of Environmental Conservation under 18 AAC 70.032 wherein pollutant concentrations may exceed the criteria of the Alaska Water Quality Standards for the proscribed pollutants.

MLLW means mean lower low water.

NMFS means National Marine Fisheries Service.

National Pollutant Discharge Elimination System (“NPDES”) means the national program for issuing, modifying, revoking and reissuing, terminating, monitoring and enforcing permits, and imposing and enforcing pretreatment requirements, under sections 307, 402, 318 and 405 of CWA.

OW means EPA Region 10's Office of Water.

P.L. means (U.S.) Public Law.

Point source means any discernible, confined and discrete conveyance, including but not limited to, any pipe, ditch, channel, tunnel, conduit, well, discrete fissure, container, rolling stock, concentrated animal feeding operation, landfill leachate collection system, vessel or other floating craft from which pollutants are or may be discharged. This term does not include return flows from irrigated agriculture or agricultural storm water runoff.

Pollutant means dredged spoil, solid waste, incinerator residue, filter backwash, sewage, garbage, sewage sludge, munitions, chemical wastes, biological materials, radioactive materials, heat, wrecked or discarded equipment, rock, sand, cellar dirt and industrial, municipal, and agricultural waste discharged into water.

Process wastewater means any water which, during manufacturing or processing, comes into direct contact with or results from the production or use of any raw material, intermediate product, finished product, byproduct, or waste product.

Sanitary wastes means human body waste discharged from toilets and urinals.

Severe property damage means substantial physical damage to property, damage to the treatment facilities which causes them to become inoperable, or substantial and permanent loss of natural resources which can reasonably be expected to occur in the absence of a bypass. Severe property damage does not mean economic loss caused by delays in production.

Sewage means human body wastes and the wastes from toilets and other receptacles intended to receive or retain body wastes.

SIP means seawater injection plant.

STP means seawater treatment plant.

Technology-based limit means a permit limit or condition based upon EPA's technology-based effluent limitation guidelines or EPA's best professional judgment.

TSS means total suspended solids.

USFWS means U.S. Fish and Wildlife Service.

Upset means an exceptional incident in which there is unintentional and temporary noncompliance with permit effluent limitations because of factors beyond the reasonable control of the permittee. An upset does not include noncompliance to the extent caused by operational error, improperly designed treatment facilities, inadequate treatment facilities, lack of preventive maintenance, or careless or improper operation.

Variance means any mechanism or provision under section 301 or 316 of CWA or under 40 CFR part 125, or in the applicable "effluent limitations guidelines" which allows modification to or waiver of the generally applicable effluent limitation requirements or time deadlines of CWA. This includes provisions which allow the establishment of alternative limitations based on fundamentally different factors or on sections 301(c), 301(g), 301(h), 301(i), or 316(a) of CWA.

Water depth means the depth of the water between the surface and the sea floor as measured at mean lower low water (0.0).

Water quality-based limit means a permit limit derived from a state water quality standard or an appropriate national water quality criteria.

Waters of the United States or waters of the U.S. means:

- (a) All waters which are currently used, were used in the past, or may be susceptible to use in interstate or foreign commerce, including all waters which are subject to the ebb and flow of the tide;
- (b) All interstate waters, including interstate wetlands;
- (c) All other waters such as intrastate lakes, rivers, streams (including intermittent streams), mudflats, sandflats, wetlands, sloughs, prairie potholes, wet meadows, playa lakes, or natural ponds the use, degradation, or destruction of which would affect or could affect interstate or foreign commerce including any such waters:
 - (1) Which are or could be used by interstate or foreign travelers for recreational or other purposes;
 - (2) From which fish or shellfish are or could be taken and sold in interstate or foreign commerce; or
 - (3) Which are used or could be used for industrial purposes by industries in interstate commerce;
- (d) All impoundments of waters otherwise defined as waters of the United States under this definition;
- (e) Tributaries of waters identified in paragraphs (a) through (d) of this definition;
- (f) The territorial sea; and
- (g) Wetlands adjacent to waters (other than waters that are themselves wetlands) identified in paragraphs (a) through (f) of this definition.

13 REFERENCES

USEPA. 1991. Technical support document for water quality-based toxics control. Office of Water, Washington, D.C. EPA/505/2-90-001.

USEPA. 1993. Guidance manual for developing best management practices (BMP). Office of Water, Washington, D.C. EPA/833/2-93-004.

USEPA. 1996. NPDES permit writers' manual. Office of Wastewater Management, Washington, D.C. EPA/833/B-96-003.

Figure 1: Location of BPXA's Liberty Island Project.

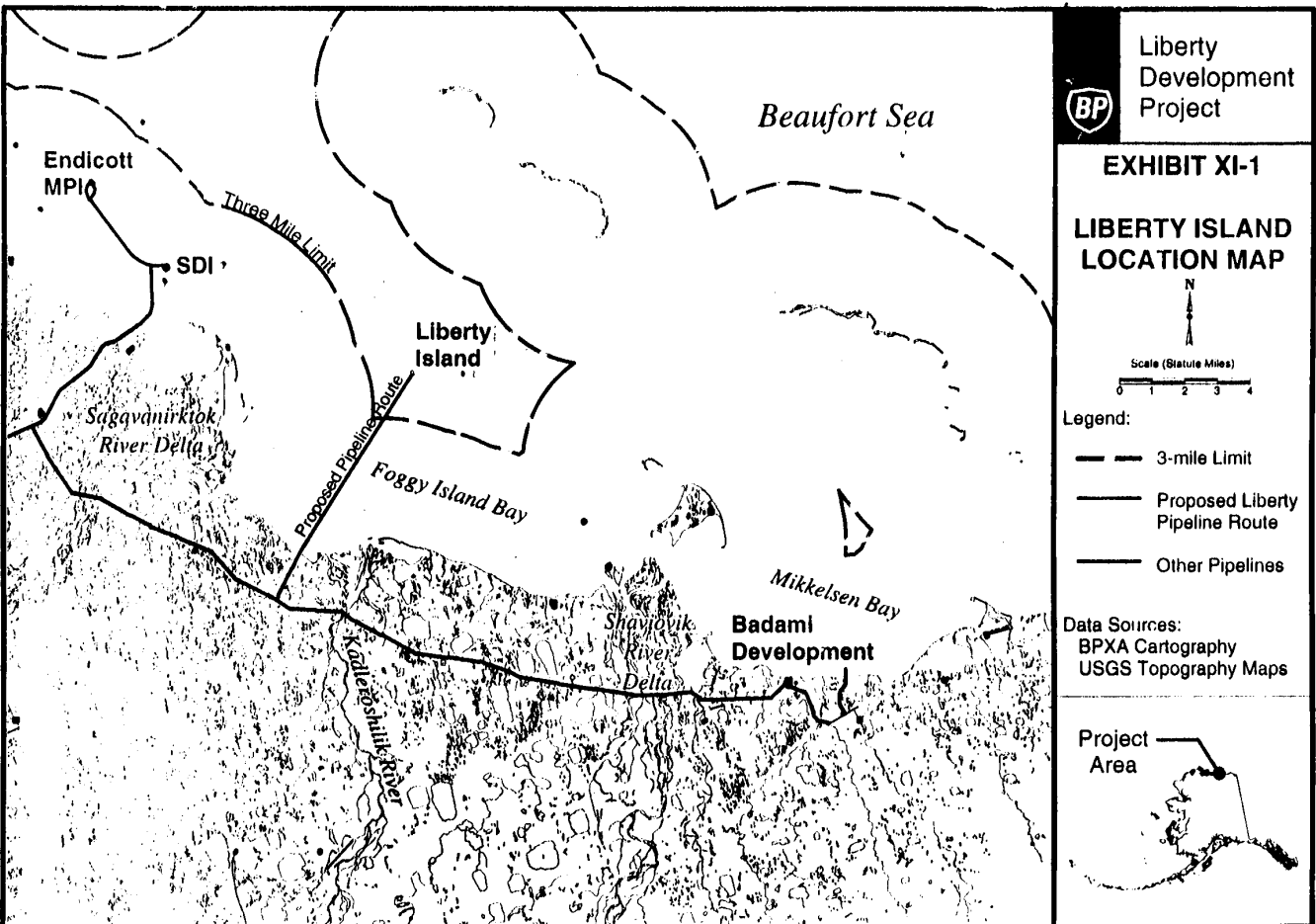
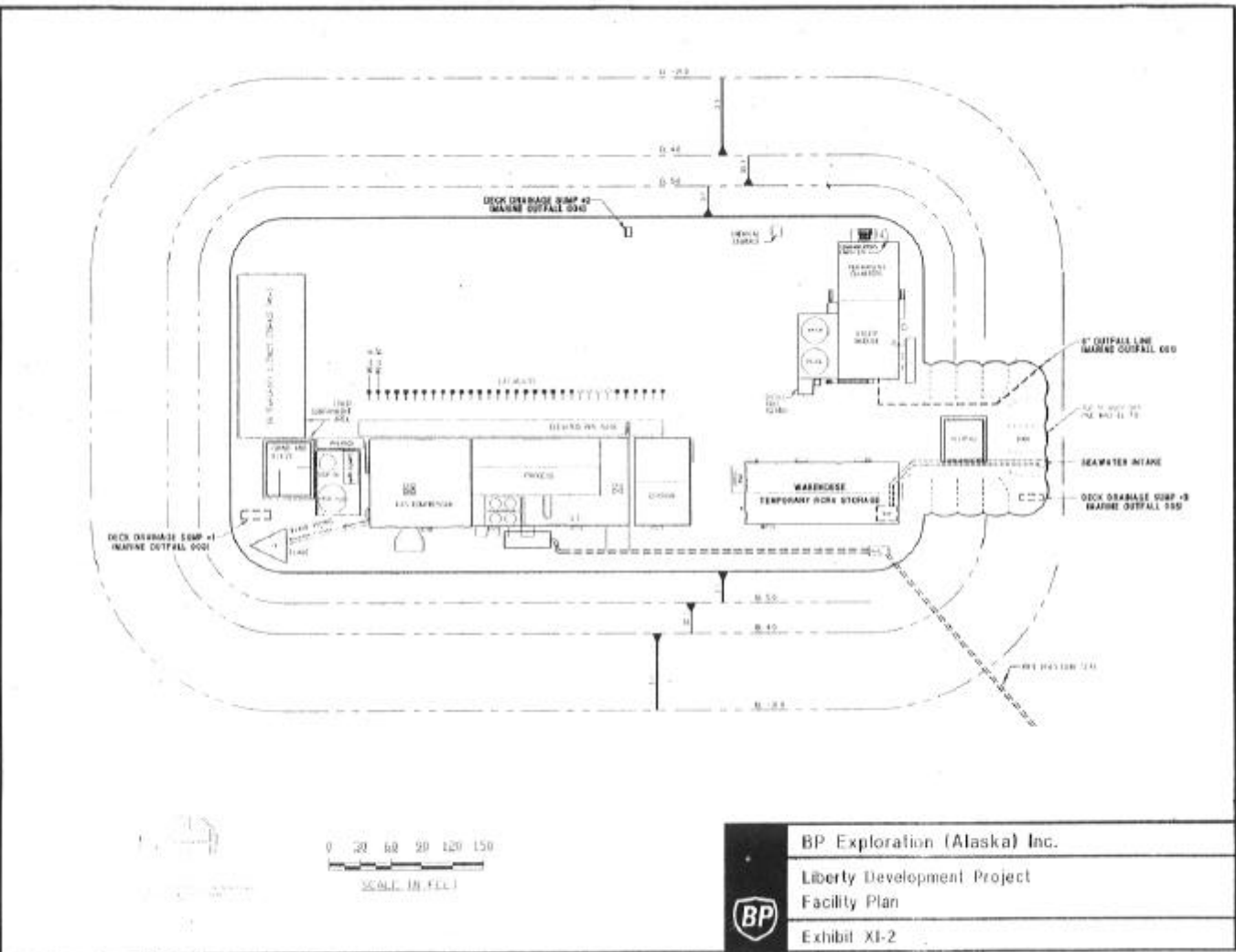

Figure 2: Diagram of BPXA's Liberty Island Project.



**BPXA's Liberty Island Oil and Gas Development Project NPDES
Proposed Final Permit AK-005314-7 and Responses to Public
Comments on the Issuance of NPDES Permit No. AD-005314-7**

Proposed Final

NPDES Permit No.: AK-005314-7

United States Environmental Protection Agency
Region 10
1200 Sixth Avenue
Seattle, Washington 98101

AUTHORIZATION TO DISCHARGE UNDER THE
NATIONAL POLLUTANT DISCHARGE ELIMINATION SYSTEM

In compliance with the provisions of the Clean Water Act, 33 U.S.C. §1251 et seq., as amended by the Water Quality Act of 1987, P.L. 100-4 (the "Act" or "CWA"),

BP Exploration (Alaska), Inc.
900 East Benson Boulevard
P.O. Box 196612
Anchorage, Alaska 99519-6612

is authorized to discharge from

Liberty Island oil and gas development project (the "facility"),
a facility classified as SIC No. 1311 and
located on the North Slope, Alaska,

to

the **Beaufort Sea** (the "receiving waters"),
at Latitude 70°16'45" north, Longitude 147°33'29" west, and
in USGS Hydrologic Unit No. 19060401,

in accordance with discharge point(s), effluent limitations, monitoring requirements and other conditions set forth herein.

The permit shall become effective _____

The permit and the authorization to discharge shall expire at midnight, _____

The permittee shall reapply for a permit reissuance on or before _____,
180 days before the expiration of this permit, if the permittee intends to continue operations and discharges at the facility beyond the term of this permit.

Signed this ____ day of _____.

Randall F. Smith
Director
Office of Water

TABLE OF CONTENTS

	<u>page</u>
I. EFFLUENT LIMITS AND MONITORING	4
A. Summary Table	4
B. Other Effluent Conditions	5
II. BEST MANAGEMENT PRACTICES PLAN	6
A. Purpose and Objectives	6
B. Documentation	6
C. Modification of the BMP Plan	7
III. COMPLIANCE REQUIREMENTS	8
A. Duty to Comply	8
B. Proper Operation and Maintenance	8
C. Duty to Mitigate	8
D. Toxic Pollutants	8
E. Removed Substances	8
F. Need to Halt or Reduce Activity not a Defense	8
G. Bypass of Wastewater Treatment	9
H. Upset Conditions	9
I. Inspection and Entry	10
J. Penalties for Violations of Permit Conditions	10
IV. RECORDING AND REPORTING REQUIREMENTS	11
A. Duty to Provide Information	11
B. Records Contents	11
C. Submittal of Reports	12
D. Retention of Records and Reports	12
E. On-site Availability of Records and Reports	12
F. Availability of Reports for Public Review	12
G. Planned Changes	12
H. Notice of New Introduction of Pollutants	13
I. Anticipated Noncompliance	13
J. Reporting of Noncompliance	13
V. GENERAL PROVISIONS	14
A. Permit Changes and Other Actions	14
B. Duty to Reapply at least 180 days before Expiration Date	14
C. Incorrect Information and Omissions	14
D. Signatory Requirements	14
E. Property Rights	15
F. Severability	15
G. Transfers	16
H. Oil and Hazardous Substance Liability	16

- I. State Laws 16
- J. Reopening of the Permit 16

- VI. DEFINITIONS and ACRONYMS 16**

I. EFFLUENT LIMITS AND MONITORING

During the term of the permit, the permittee is authorized to discharge wastewater from the facility through outfalls 001, 001C, 002, 003, 004, 005 and 006 in accordance with the following conditions.

A. Summary Table

Table 1. Limits and Monitoring for Discharges 001, 001c and 006				
Parameter	Average Monthly Limit	Maximum Daily Limit	Sampling Method and Frequency	Reported Values
Combined wastewater, Discharge 001				
Flow, 001	0.1 MGD	0.2 MGD	Recording, daily	Average monthly and maximum daily, MGD
TRC, 001	10 µg/L	20 µg/L	Grab, daily	Average monthly and maximum daily, µg/L
Temperature, 001	no limit	no more than 10°C above or below ambient	Recording or meter for effluent and ambient, daily	Average monthly and maximum daily difference of effluent minus ambient, °C
Sewage plant, Discharge 001c				
Flow, 001c	10,000 gal/day	20,000 gal/day	Recording or meter, daily*	Average monthly and maximum daily*, MGD
TSS, 001c	30 mg/L; at least 85% removal	60 mg/L	Grab, weekly*	Average monthly and maximum daily*, mg/L; percent removal
BOD5, 001c	30 mg/L; at least 85% removal	60 mg/L	Grab, weekly*	Average monthly and maximum daily*, mg/L; percent removal
Fecal coliform bacteria, 001c	200 FC/100 ml	400 FC/100 ml	Grab, weekly*	Average monthly and maximum daily*, FC/100 ml
TRC, 001c	0.1 mg/L	0.2 mg/L	Grab, daily*	Average monthly and maximum daily*, mg/L
pH, 001c	no limit	no more than 8.5, no less than 6.5	Grab or meter, daily*	Minimum and maximum monthly values*, pH units
Construction dewatering, Discharge 006				
Flow, 006	no limit	no limit	Calculation or meter, daily*	Average monthly and maximum daily*, MGD
Oily sheen, 006	no visible sheen in effluent prior to discharge		Visual, hourly*	Time and date of the presence of a visible sheen; corrective action

Note: * Monitoring and reporting are required during periods of surface discharge only.

1. Monitoring procedures. Monitoring shall be conducted according to test procedures approved under 40 CFR Part 136, unless other test procedures have been approved by EPA.

Samples taken in compliance with the effluent monitoring requirements of the permit shall be collected from the effluent stream prior to discharge into the receiving waters. Samples and measurements shall be representative of the volume and nature of the monitored discharge.

The permittee shall ensure that all effluent monitoring is conducted in compliance with good quality assurance and control procedures and the requirements of the permit.

2. Additional monitoring by the permittee. If the permittee monitors any pollutant discharge more frequently than the permit requires using test procedures approved under 40 CFR 136 or as specified in the permit, the permittee shall include the results of this monitoring in the calculation and reporting of the data submitted in the discharge monitoring report.
3. Report of monitoring results. An annual discharge monitoring report (DMR) of the results of effluent monitoring shall be submitted to EPA on or before January 31st of the calendar year following the monitoring. The annual report shall include tabular presentations of the date, and time of monitoring, and the measurements of flow and effluent parameters. The annual report shall also include a table reporting any non-compliant discharges, describing the date and time, effluent characteristics, and cause and resolution of the discharge. (The permittee has a separate and independent responsibility to promptly report a non-compliant discharge as provided in this permit.)
4. Modification of monitoring program. The monitoring program may be modified if EPA determines that it is appropriate. In addition, modification may be requested by the permittee. The modified program may include changes in survey (1) frequencies, (2) parameters, or (3) methods.

B. Other Effluent Conditions

1. Toxic and Other Deleterious Substances. There shall be no discharge of toxic and other deleterious substances.
2. Floating Solids, Visible Foam or Oily Wastes. There shall be no discharge of floating solids or visible foam in other than trace amounts. Additionally, discharges shall not cause a film, sheen or discoloration on the surface or floor of the water body or adjoining shorelines.
3. Surfactants, Dispersants and Detergents. The discharge of surfactants, dispersants and detergents shall be minimized.
4. Sludge. Sludge removed from the treatment systems during cleaning of the treatment units shall not be reintroduced into the treatment system or

discharged to waters of the United States. The Permittee will dispose of sewage sludge either through injection into the Class I waste disposal injection well (waste disposal well), if permitted and available, or by transportation to an approved North Slope facility for treatment and disposal. The Permittee shall provide the EPA upon request with information on the Permittee's processing of sludge and disposal of solids.

II. BEST MANAGEMENT PRACTICES PLAN

Through implementation of the BMP Plan, the permittee shall ensure that methods of pollution prevention, control and treatment will be applied to all wastes and other substances discharged. The permittee shall update and continue its implementation of a Best Management Practices (BMP) Plan in accordance with the following purpose and objectives.

- A. Purpose and Objectives.** The permittee shall prevent or minimize the generation and discharge of wastes and pollutants from the facility to the waters of the United States through implementation of a BMP Plan. Pollution should be prevented or reduced at the source or recycled in an environmentally safe manner whenever feasible. Disposal of wastes into the environment should be conducted in such a way as to have a minimal environmental impact.

The permittee shall develop its BMP Plan consistent with these objectives.

1. The number and quantity of pollutants and the toxicity of effluent generated, discharged or potentially discharged at the facility shall be minimized by the permittee to the extent feasible by managing each influent waste stream in the most appropriate manner.
2. Under the BMP Plan, and any Standard Operating Procedures (SOPs) included in the Plan, the permittee shall ensure proper operation and maintenance of the treatment facility.

B. Documentation.

1. The permittee shall develop a BMP Plan in accordance with good engineering practices. The permittee shall develop its BMP Plan consistent with the general guidance contained in the Guidance Manual for Developing Best Management Practices (USEPA 1993), or any subsequent revisions. The permittee shall provide the necessary plot plans, drawings, or maps in its BMP Plan.

The BMP Plan will be organized and written with the following structure:

- a. Name and location of the facility;

- b. Statement of BMP policy;
 - c. Identification and assessment of potential effects of the pollutant discharges;
 - d. Specific management practices and standard operating procedures to achieve the above objectives, including, but not limited to,
 - (1) the modification of equipment, facilities, technology, processes, and procedures, and
 - (2) the improvement in management, inventory control, materials handling, or general operational phases of the facility;
 - e. Good housekeeping;
 - f. Preventative maintenance;
 - g. Inspections and records; and
 - h. Employee training.
2. The BMP Plan will include the following provisions concerning its review:
- a. Provide for a review by the facility manager and appropriate staff; and
 - b. Include a statement that the above review has been completed and that the BMP Plan fulfills the requirements set forth in the permit. This statement shall be certified by the dated signature of the facility manager.
3. The permittee shall maintain a copy of its BMP Plan at its facility and shall make the plan available to EPA for review and approval upon request.

C. Modification of the BMP Plan.

1. The permittee shall amend the BMP Plan whenever there is a change in the facility, its operations, or other circumstances which materially increase the generation of pollutants and their release or potential release to the receiving waters. The permittee shall also amend the BMP Plan when facility operations covered by the BMP Plan change. Any such changes to the BMP Plan will be consistent with the objectives and specific requirements listed above. All changes in the BMP Plan shall be reviewed and approved by the facility manager or his designee.

2. If a BMP Plan proves to be ineffective in achieving the general objective of preventing and minimizing the generation of pollutants and their release and potential release to the receiving waters and/or the specific requirements above, the permit and/or the BMP Plan will be subject to modification to incorporate revised BMP requirements.

III. COMPLIANCE REQUIREMENTS

- A. **Duty to Comply.** The permittee shall comply with all conditions of the permit. Any permit noncompliance constitutes a violation of the Clean Water Act and is grounds for enforcement action; for permit termination, revocation and reissuance, or modification; or for denial of a permit renewal application.
- B. **Proper Operation and Maintenance.** The permittee shall at all times properly operate and maintain all facilities and systems of treatment and control (and related appurtenances) which are installed or used by the permittee to achieve compliance with the conditions of the permit. Proper operation and maintenance also includes adequate laboratory controls and appropriate quality assurance procedures. This provision requires the operation of back-up or auxiliary facilities or similar systems which are installed by a permittee only when the operation is necessary to achieve compliance with the conditions of the permit.
- C. **Duty to Mitigate.** The permittee shall take all reasonable steps to minimize or prevent any discharge in violation of the permit which has a reasonable likelihood of adversely affecting human health or the environment.
- D. **Toxic Pollutants.** The permittee shall comply with effluent standards or prohibitions established for toxic pollutants under Section 307(a) of the Act within the time provided in the regulations that establish those standards or prohibitions.
- E. **Removed Substances.** Solids, sludge, filter residues, or other pollutants removed in the course of treatment or control of wastewaters shall be disposed of in a manner such as to prevent any pollutant from such materials from entering navigable waters.
- F. **Need to Halt or Reduce Activity not a Defense.** It will not be a defense for a permittee in an enforcement action that it would have been necessary to halt or reduce the permitted activity in order to maintain compliance with the conditions of the permit.

G. Bypass of Wastewater Treatment.

1. Bypass exceeding effluent limitations. Bypass of wastewater treatment is prohibited if such bypass will produce a discharge which exceeds the effluent limitations of the permit. EPA may take enforcement action against a permittee for a bypass, unless:
 - a. The bypass was unavoidable to prevent loss of life, personal injury, or severe property damage;
 - b. There were no feasible alternatives to the bypass, such as the use of auxiliary treatment facilities, retention of untreated wastes, or maintenance during normal periods of equipment downtime. This condition is not satisfied if adequate back-up equipment should have been installed in the exercise of reasonable engineering judgment to prevent a bypass which occurred during normal periods of equipment downtime or preventive maintenance; and
 - c. The permittee submitted notices of the bypass as follows.
 - (1) Notice of an anticipated bypass. If the permittee knows in advance of the need for a bypass, it shall submit prior notice, if possible at least 10 days before the date of the bypass.
 - (2) Notice of an unanticipated bypass. The permittee shall submit notice of an unanticipated bypass as required under "Reporting of Noncompliance (see below).

EPA may approve an anticipated bypass, after considering its adverse effects, if EPA determines that it will meet the three conditions listed below.

2. Bypass not exceeding effluent limitations. The permittee may allow any bypass to occur which does not cause effluent limitations to be exceeded, but only if it also is for essential maintenance to assure efficient operation.

H. Upset Conditions.

1. Effect of an upset. An upset constitutes an affirmative defense to an action brought for noncompliance with such technology-based permit effluent limitations if the requirements of the following paragraph are met. No determination made during administrative review of claims that noncompliance was caused by upset, and before an action for noncompliance, is final administrative action subject to judicial review.
2. Conditions necessary for a demonstration of upset. A permittee who wishes to establish the affirmative defense of upset will demonstrate, through

properly signed, contemporaneous operating logs, or other relevant evidence that:

- a. An upset occurred and that the permittee can identify the cause(s) of the upset;
- b. The permitted facility was at the time being properly operated;
- c. The permittee submitted notice of the upset as required under "Reporting of Noncompliance" (see below); and
- d. The permittee complied with any remedial measures required under "Duty to Mitigate" (see below).

3. Burden of proof. In any enforcement proceeding, the permittee seeking to establish the occurrence of an upset has the burden of proof.

I. Inspection and Entry. The permittee shall allow EPA or an authorized representative (including an authorized contractor acting as a representative of the Administrator), upon the presentation of credentials and other documents as may be required by law, to:

1. Enter upon the permittee's premises where a regulated facility or activity is located or conducted, or where records must be kept under the conditions of the permit;
2. Have access to and copy, at reasonable times, any records that must be kept under the conditions of the permit;
3. Inspect at reasonable times any facilities, equipment (including monitoring and control equipment), practices, or operations regulated or required under the permit; and
4. Sample or monitor at reasonable times, for the purpose of assuring permit compliance or as otherwise authorized by the Act, any substances or parameters at any location.

J. Penalties for Violations of Permit Conditions.

1. Civil and administrative penalties. Any person who violates a permit condition implementing CWA §§ 301, 302, 306, 307, 308, 318, or 405 shall be subject to a civil or administrative penalty, not to exceed the maximum amounts authorized by Sections 309(d) and 309(g) of the Act and the Federal Civil Penalties Inflation Adjustment Act (28 U.S.C. § 2461 note) as amended by the Debt Collection Improvement Act (31 U.S.C. § 3701 note).

2. Negligent violations. Any person who negligently violates a permit condition implementing CWA §§ 301, 302, 306, 307, 308, 318, or 405 shall, upon conviction, be punished by a fine and/or imprisonment as specified in Section 309(c)(1) of the Act.
3. Knowing violations. Any person who knowingly violates a permit condition implementing CWA §§ 301, 302, 306, 307, 308, 318, or 405 shall, upon conviction, be punished by a fine and/or imprisonment as specified in Section 309(c)(2) of the Act.
4. Knowing endangerment. Any person who knowingly violates a permit condition implementing CWA §§ 301, 302, 306, 307, 308, 318, or 405, and who knows at that time that he thereby places another person in imminent danger of death or serious bodily injury, shall, upon conviction, be subject to a fine and/or imprisonment as specified in Section 309(c)(3) of the Act.
5. False statements. Section 309(c)(4) of the Act provides that any person who knowingly makes any false material statement, representation, or certification in any application or notice of intent, record, report, plan, or other document filed or required to be maintained under this Act or who knowingly falsifies, tampers with, or renders inaccurate any monitoring device or method required to be maintained under this Act, shall be punished by a fine of not more than \$10,000, or by imprisonment for not more than 2 years, or by both.

Except as provided in explicit variances allowed within this permit (see "Bypass of Treatment Facilities" and "Upset Conditions"), nothing in this permit shall be construed to relieve a permittee of the civil or criminal penalties for noncompliance.

IV. RECORDING AND REPORTING REQUIREMENTS

- A. **Duty to Provide Information.** The permittee shall furnish to EPA, within a reasonable time, any information which EPA may request to determine whether cause exists for modifying, revoking, and reissuing, or terminating the permit, or to determine compliance with the permit. The permittee shall also furnish to EPA, upon request, copies of records and reports required to be kept by the permit.
- B. **Records Contents.** Records of monitoring information shall include at least the following information:
 1. The name(s) of the individual(s) who performed the sampling or measurements;
 2. The date, exact place, and time of sampling or measurements;

3. The name(s) of the individual(s) who performed the analyses;
 4. The date(s) analyses were performed;
 5. The analytical techniques or methods used; and
 6. The results of such analyses.
- C. Submittal of Reports.** An annual report of effluent monitoring and other information required by the permit will be submitted to EPA at the following address:
- original to:
- U.S. Environmental Protection Agency, Region 10
NPDES Compliance Unit (OW-133)
1200 Sixth Avenue
Seattle, Washington 98101
- D. Retention of Records and Reports.** The permittee shall retain copies of all monitoring information, including all calibration and maintenance records and all original strip chart recordings for continuous monitoring instrumentation, copies of all reports required by the permit, and records of all data used to complete the application for the permit, for a period of at least five years from the date of the sample, measurement, report, or application. This period may be extended by request of EPA at any time.
- E. On-site Availability of Records and Reports.** Copies of this NDPEs permit, monitoring reports, and other technical documents required under the permit shall be maintained on-site during the duration of activity at the permitted location.
- F. Availability of Reports for Public Review.** Except for data determined to be confidential under 40 CFR Part 2, all reports prepared in accordance with the terms of the permit will be available for public review at the offices of EPA. As required by the Act, permit applications, permits, and effluent data will not be considered confidential.
- G. Planned Changes.** The permittee shall give sixty (60) days advance notice to EPA as soon as possible of any planned physical alterations of or additions to the permitted facility. Notice is required only when:
1. The alteration of or addition to the facility could result in noncompliance with the explicit effluent limitations of the permit;
 2. The alteration of or addition to the facility could significantly change the nature or increase the quantity of pollutants discharged which are not limited explicitly in the permit; or

3. The alteration of or addition to the facility may meet one of the criteria for determining whether the facility is a new source as determined in 40 CFR § 122.29(b).

H. Notice of New Introduction of Pollutants.

1. The permittee shall provide sixty (60) days advance notice to EPA of:
 - a. Any new introduction of pollutants into the treatment works from an indirect discharger which would be subject to Sections 301 or 306 of the Act if it were directly discharging those pollutants; and
 - b. Any substantial change in the volume or character of pollutants being introduced into the treatment works by a source introducing pollutants into the treatment works at the time of issuance of the permit.
2. For the purposes of this section, adequate notice will include information on:
 - a. The quality and quantity of effluent to be introduced into such treatment works; and
 - b. Any anticipated impact of the change on the quantity or quality of effluent to be discharged from such treatment works.

- I. Anticipated Noncompliance.** The permittee shall also give advance notice to EPA of any planned changes in the permitted facility or activity which may result in noncompliance with permit requirements.

J. Reporting of Noncompliance.

1. The following occurrences of noncompliance shall be reported by telephone to EPA (206-553-1846) and the Alaska Department of Environmental Conservation (907-269-7500) within 24 hours from the time the permittee becomes aware of the circumstances:
 - a. Any noncompliance which may endanger human health or the environment;
 - b. Any violation of a maximum daily discharge limitation for any of the pollutants listed in the permit (see "Effluent Limitations" above);
 - c. Any unanticipated bypass which exceeds any effluent limitation in the permit (see "Bypass of Treatment Facilities" above); or
 - d. Any upset which exceeds any effluent limitation in the permit (see "Upset Conditions" above).

2. A written notice of the preceding occurrences of noncompliance will also be provided to EPA (see "Submittal of Reports" above) within five (5) days of the time that the permittee becomes aware of the circumstances which lead to the noncompliance.
3. Instances of noncompliance not required to be reported within 24 hours will be reported at the time that the next discharge monitoring report is submitted.

The written submission will contain:

- a. A description of the noncompliance and its cause;
- b. The period of noncompliance, including exact dates and times;
- c. The estimated time noncompliance is expected to continue if it has not been corrected; and
- d. Steps taken or planned to reduce, eliminate, and prevent reoccurrence of the noncompliance.

V. GENERAL PROVISIONS

- A. Permit Changes and Other Actions.** The permit may be modified, revoked, and reissued, or terminated for cause. The filing of a request by the permittee for a permit modification, revocation, and reissuance, or termination, or a notification of planned changes or anticipated noncompliance, does not stay any permit condition.
- B. Duty to Reapply at least 180 days before Expiration Date.** If the permittee wishes to continue an activity regulated by the permit after the expiration date of the permit, the permittee must apply for and obtain a new permit. The application should be submitted at least 180 days before the expiration date of the permit in order to ensure the timely reissuance of the permit.
- C. Incorrect Information and Omissions.** When the permittee becomes aware that it failed to submit any relevant facts in a permit application, or submitted incorrect information in a permit application or any report to EPA, it will promptly submit such facts or information.
- D. Signatory Requirements.** All applications, reports or information submitted to EPA will be signed and certified.
 1. All permit applications will be signed as follows:
 - a. For a corporation: by a responsible corporate officer.

- b. For a partnership or sole proprietorship: by a general partner or the proprietor, respectively.
 - c. For a municipality, state, federal, or other public agency: by either a principal executive officer or ranking elected official.
 2. All reports required by the permit and other information requested by will be signed by a person described above or by a duly authorized representative of that person. A person is a duly authorized representative only if:
 - a. The authorization is made in writing by a person described above and submitted to EPA, and
 - b. The authorization specified either an individual or a position having responsibility for the overall operation of the regulated facility or activity, such as the position of plant manager, operator of a well or a well field, superintendent, position of equivalent responsibility, or an individual or position having overall responsibility for environmental matters for the company. (A duly authorized representative may thus be either a named individual or any individual occupying a named position.)
 3. Changes to authorization. If an authorization under "Signatory Requirements" is no longer accurate because a different individual or position has responsibility for the overall operation of the facility, a new authorization satisfying the requirements this section shall be submitted to EPA prior to or together with any reports, information, or applications to be signed by an authorized representative.
 4. Certification. Any person signing a document under this section shall make the following certification:

"I certify under penalty of law that this document and all attachments were prepared under my direction or supervision in accordance with a system designed to assure that qualified personnel properly gather and evaluate the information submitted. Based on my inquiry of the person or persons who manage the system, or those persons directly responsible for gathering the information, the information submitted is, to the best of my knowledge and belief, true, accurate, and complete. I am aware that there are significant penalties for submitting false information, including the possibility of fine and imprisonment for knowing violations."
- E. **Property Rights.** The issuance of the permit does not convey any property rights of any sort, or any exclusive privileges, nor does it authorize any injury to private property or any invasion of personal rights, nor any infringement of federal, state, or local laws or regulations.
- F. **Severability.** The provisions of the permit are severable, and if any provision of the permit, or the application of any provision of the permit to any circumstance, is

held invalid, the application of such provision to other circumstances, and the remainder of the permit, will not be affected.

- G. Transfers.** The permit may be automatically transferred to a new permittee if:
1. The current permittee notifies EPA at least 30 days in advance of the proposed transfer date;
 2. The notice includes a written agreement between the existing and new permittees containing a specific date for transfer of permit responsibility, coverage, and liability between them; and
 3. EPA does not notify the existing permittee and the proposed new permittee of its intent to modify, or revoke and reissue the permit. If this notice is not received, the transfer is effective on the date specified in the agreement mentioned in the preceding paragraph.
- H. Oil and Hazardous Substance Liability.** Nothing in the permit shall be construed to preclude the institution of any legal action or relieve the permittee from any responsibilities, liabilities, or penalties to which the permittee is or may be subject under Section 311 of the Act.
- I. State Laws.** Nothing in the permit will be construed to preclude the institution of any legal action or relieve the permittee from any responsibilities, liabilities, or penalties established pursuant to any applicable state law or regulation under authority preserved by Section 510 of the Act.
- J. Reopening of the Permit.** If these permit requirements are insufficient to achieve Alaska State Water Quality Standards, EPA may reopen and modify the permit in accordance with 40 CFR § 122.44(d)(1)(C)(4) and 40 CFR § 122.62 to include more stringent effluent limitations and/or additional monitoring requirements.

VI. DEFINITIONS and ACRONYMS

§ means section or subsection.

AAC means Alaska Administrative Code.

ADEC means Alaska Department of Environmental Conservation.

Average monthly discharge means the average of "daily discharges" over a monitoring month, calculated as the sum of all daily discharges measured during a monitoring month divided by the number of daily discharges measured during that month. It may also be referred to as the "monthly average discharge."

Best management practices ("BMPs") means schedules of activities, prohibitions of practices, maintenance procedures and other management practices to prevent or

reduce the pollution of "waters of the United States." BMPs also include treatment requirements, operating procedures and practices to control plant site runoff, spillage or leaks, sludge or waste disposal, or drainage from raw material storage.

BOD5 means five-day biochemical oxygen demand.

Bypass means the intentional diversion of waste streams from any portion of a treatment facility.

°C means degrees Celsius.

CFR means Code of Federal Regulations.

CWA means the Clean Water Act, (formerly referred to as the Federal Water Pollution Control Act or Federal Water Pollution Control Act Amendments of 1972) Public Law 92-500, as amended by Public Law 95-217, Public Law 95-576, Public Law 96-483 and Public Law 97-117, 33 U.S.C. 1251 et seq.

Daily discharge means the discharge of a pollutant measured during a calendar day or any 24-hour period that reasonably represents the calendar day for purposes of sampling. For pollutants with limitations expressed in units of mass, the "daily discharge" is calculated as the total mass of the pollutant discharged over the day. For pollutants with limitations expressed in other units of measurement, the "daily discharge" is calculated as the average measurement of the pollutant over the day.

Daily maximum discharge means the highest allowable "daily discharge" and is also referred to as the "maximum daily discharge."

Discharge of a pollutant means any addition of any "pollutant" or combination of pollutants to "waters of the United States" from any "point source" or any addition of any pollutant or combination of pollutants to the waters of the "contiguous zone" or the ocean from any point source other than a vessel or other floating craft which is being used as a means of transportation.

Discharge Monitoring Report ("DMR") means the EPA uniform national form, including any subsequent additions, revisions, or modifications for the reporting of self-monitoring results by permittees. DMRs must be used by "approved States" as well as by EPA.

Effluent limitation means any restriction imposed by the Director on quantities, discharge rates, and concentrations of "pollutants" which are "discharged" from "point sources" into "waters of the United States," the waters of the "contiguous zone," or the ocean.

EOA means Eastern Operations Area.

EPA means U.S. Environmental Protection Agency.

ESA means the Endangered Species Act.

°F means degrees Fahrenheit.

Facility or activity means any NPDES "point source" or any other facility or activity (including land or appurtenances thereto) that is subject to regulation under the NPDES program.

lb means pound.

Maximum means the highest measured discharge or pollutant in a waste stream during the time period of interest.

Maximum daily discharge limitation means the highest allowable "daily discharge."

MGD means million gallons per day.

mg/L means milligrams per liter.

Mixing zone means the zone of dilution authorized by the Alaska Department of Environmental Conservation under 18 AAC 70.032 wherein pollutant concentrations may exceed the criteria of the Alaska Water Quality Standards for the proscribed pollutants.

MLLW means mean lower low water.

NMFS means National Marine Fisheries Service.

National Pollutant Discharge Elimination System ("NPDES") means the national program for issuing, modifying, revoking and reissuing, terminating, monitoring and enforcing permits, and imposing and enforcing pretreatment requirements, under sections 307, 402, 318 and 405 of CWA.

OW means EPA Region 10's Office of Water.

P.L. means (U.S.) Public Law.

Point source means any discernible, confined and discrete conveyance, including but not limited to, any pipe, ditch, channel, tunnel, conduit, well, discrete fissure, container, rolling stock, concentrated animal feeding operation, landfill leachate collection system, vessel or other floating craft from which pollutants are or may be discharged. This term does not include return flows from irrigated agriculture or agricultural storm water runoff.

Pollutant means dredged spoil, solid waste, incinerator residue, filter backwash, sewage, garbage, sewage sludge, munitions, chemical wastes, biological materials, radioactive materials, heat, wrecked or discarded equipment, rock, sand, cellar dirt and industrial, municipal, and agricultural waste discharged into water.

Process wastewater means any water which, during manufacturing or processing, comes into direct contact with or results from the production or use of any raw material, intermediate product, finished product, byproduct, or waste product.

Sanitary wastes means human body waste discharged from toilets and urinals.

Severe property damage means substantial physical damage to property, damage to the treatment facilities which causes them to become inoperable, or substantial and permanent loss of natural resources which can reasonably be expected to occur in the absence of a bypass. Severe property damage does not mean economic loss caused by delays in production.

Sewage means human body wastes and the wastes from toilets and other receptacles intended to receive or retain body wastes.

SIP means seawater injection plant.

sp. means species.

STP means seawater treatment plant.

Technology-based limit means a permit limit or condition based upon EPA's technology-based effluent limitation guidelines or EPA's best professional judgment.

TSS means total suspended solids.

USFWS means U.S. Fish and Wildlife Service.

Upset means an exceptional incident in which there is unintentional and temporary noncompliance with permit effluent limitations because of factors beyond the reasonable control of the permittee. An upset does not include noncompliance to the extent caused by operational error, improperly designed treatment facilities, inadequate treatment facilities, lack of preventive maintenance, or careless or improper operation.

Variance means any mechanism or provision under section 301 or 316 of CWA or under 40 CFR part 125, or in the applicable "effluent limitations guidelines" which allows modification to or waiver of the generally applicable effluent limitation requirements or time deadlines of CWA. This includes provisions which allow the establishment of alternative limitations based on fundamentally different factors or on sections 301(c), 301(g), 301(h), 301(i), or 316(a) of CWA.

Water depth means the depth of the water between the surface and the sea floor as measured at mean lower low water (0.0).

Water quality-based limit means a permit limit derived from a state water quality standard or an appropriate national water quality criteria.

Waters of the United States or waters of the U.S. means:

- (a) All waters which are currently used, were used in the past, or may be susceptible to use in interstate or foreign commerce, including all waters which are subject to the ebb and flow of the tide;
- (b) All interstate waters, including interstate wetlands;
- (c) All other waters such as intrastate lakes, rivers, streams (including intermittent streams), mudflats, sandflats, wetlands, sloughs, prairie potholes, wet meadows, playa lakes, or natural ponds the use, degradation, or destruction of which would affect or could affect interstate or foreign commerce including any such waters:
 - (1) Which are or could be used by interstate or foreign travelers for recreational or other purposes;
 - (2) From which fish or shellfish are or could be taken and sold in interstate or foreign commerce; or
 - (3) Which are used or could be used for industrial purposes by industries in interstate commerce;
- (d) All impoundments of waters otherwise defined as waters of the United States under this definition;
- (e) Tributaries of waters identified in paragraphs (a) through (d) of this definition;
- (f) The territorial sea; and
- (g) Wetlands adjacent to waters (other than waters that are themselves wetlands) identified in paragraphs (a) through (f) of this definition.

Issuance of NPDES permit no. AK-005314-7

BP Exploration (Alaska), Inc.,

**Liberty Island Oil and Gas Development and Production Project,
Outer Continental Shelf (OCS) of Foggy Island Bay, Beaufort Sea, Arctic Ocean**

Draft Response to Public Comments

EPA provides the following responses to public comments on the issuance of NPDES permit no. AK-005314-7 to BP Exploration (Alaska), Inc., for its Liberty Island oil and gas development and production project on the Outer Continental Shelf (OCS) of Foggy Island Bay, Beaufort Sea, Arctic Ocean.

Comment: An environmental consortium of thirteen non-profit, non-governmental groups representing tens of thousands of Alaskan citizens urges EPA to withhold the issuance of National Pollutant Discharge Elimination System (NPDES) permit based upon the inadequate analysis of the resources – subsistence fishing and hunting, threatened and endangered species, marine and anadromous fish populations, the unique Boulder Patch Community, and habitat of the coastal sea – that would be potentially affected by the discharge and disposal of wastes and by the probable spills and pipeline breakage. Members of the consortium include the Trustees for Alaska, Alaska Center for the Environment, Alaska Community Action on Toxics, Alaska Conservation Alliance, Alaska Wilderness League, Center for Biological Diversity, Defenders of Wildlife, Northern Alaska Environmental Center, Sierra Club, and The Wilderness Society. [Comment# 0135-001]

Response: EPA Region 10's responsibility in the issuance of NPDES permit no. AK-005314-7 to BP Exploration (Alaska), Inc., for its Liberty Island oil and gas development and production project on the Outer Continental Shelf (OCS) of Foggy Island Bay, Beaufort Sea, Arctic Ocean, is to ensure that the discharges associated with the construction of the gravel island facility and its subsequent discharges of wastewater during operations is protective of water quality and the marine habitat of the receiving waters of the Beaufort Sea. To this end EPA has taken the conservative position that it will apply Alaska Water Quality Standards in controlling the discharges of the facility during construction and operations, although the project occurs approximately five miles from the Alaskan coast and approximately two miles beyond the coastal seas under the jurisdiction of the State of Alaska. The NPDES permit limits, conditions and requirements control the pollutant discharges of the proposed facility and are protective of water quality and the marine habitat of the receiving waters.

No changes have been made to the draft permit in response to this comment.

Comment: The Trustees for Alaska and an environmental consortium of twelve other non-profit, non-governmental groups representing tens of thousands of Alaskan citizens states that the evaluation of water quality impacts should consider all pollution and not ignore the impacts that occur within “mixing zones.” [Comment# 0135-042]

Response: EPA finds that the “mixing zone” of 100 ft radius (less than 31,416 sq. ft. and 0.7 acre) proposed for the wastewater discharges during the construction and operation of the Liberty Island Project is protective of both acute and chronic toxicity and provides for the initial dilution of pollutants (sediments, turbidity, residues, dissolved salt-solids, temperature, pH, total residual chlorine, and bacteria) as a discharge stream mixing with the receiving water. EPA expects that an increase in the biomass and abundance of benthic marine life (especially mollusks) will occur in the immediate vicinity of the point of discharge at the outfall terminus in conjunction with the concentration and discharge of sediment and organic debris that results from the seawater treatment process. Changes in the benthic environment and community will shift towards and attain natural ambient conditions within 100 ft from the outfall. EPA expects that no detectable changes will occur in the pelagic marine life within the mixing zone. EPA finds these projected effects on water and sediment quality and the marine community to be acceptable.

No changes have been made to the draft permit in response to this comment.

Comment: BP Exploration (Alaska), Inc., notes that sediment (settleable solids) is not expressly addressed as a pollutant in section III.C.93 of the draft EIS. [Comment# 0136-118]

Response: EPA has addressed sediments in its fact sheet and NPDES permit. *No changes have been made to the draft permit in response to this comment.*

Comment: BP Exploration (Alaska), Inc., notes that several typographical translation errors occurred in the fact sheet and draft permit due to font conversions between the composition and publication of these documents. [Comments# 0136-222, 0136-223, 0136-224, 0136-225, 0136-229]

Response: EPA apologizes for the several font substitutions noted in the applicant’s comment letter. EPA will ensure that the final permit distributed by mail will not include such font substitutions.

Comment: BP Exploration (Alaska), Inc., comments that the Liberty Development Project is located in federally administered Outer Continental Shelf waters beyond the jurisdiction of the State of Alaska yet the permit requires compliance with the Alaska Water Quality Standards. [Comment# 0136-226, 0136-227, 0136-228, and 0136-230]

Response: EPA understands BP’s comment to be a request to reconcile certain permit terms and conditions referring to Alaska Water Quality Standards with the offshore location of the permitted facility beyond the jurisdiction of the State of Alaska. The Code

of Federal Regulations empowers EPA to establish permit conditions as required to protect the quality and environment of the receiving water and its beneficial uses on a case-by-case basis [40 CFR § 122.43 and 122.44(d)]. EPA finds that the Alaska water quality standards provide useful, convenient and appropriate criteria for this application of the protection the quality, environment and uses (industrial supply and growth and propagation of fish, shellfish and other aquatic life and wildlife) of the receiving water.

EPA appreciates BP's point that it is important to distinguish between the application of a State's standards and the application of the criteria of a State's standards in the federal waters of the Outer Continental Shelf. In response to this concern, EPA has revised the permit Part I.B to clarify that the permit utilizes Alaska water quality criteria rather than applies Alaska Water Quality Standards. *EPA has revised the draft permit at section I.B.1 to refer to criteria and section I.B to eliminate the reference to Alaska's anti-degradation policy.*

Comment: BP Exploration (Alaska), Inc., observes that several pumps rather than a single pump may be used in dewatering the construction site of the re-enforced artificial gravel island platform of the Liberty Island Project. [Comment# 0136-230]

Response: EPA provides this comment in the Agency's response to comments in order to clarify the administrative record for this permit issuance.

Ocean Discharge Criteria Evaluation – in Support of the Liberty Development Project NPDES Permit Application (URS Greiner Woodward Clyde, 1998)

This appendix was published as part of the Liberty Development and Production Plan (DPP) Draft Environmental Impact Statement (EIS) and was not revised for the Final EIS. The reader is referred to this appendix in the Draft EIS. This appendix is also available on the CD-ROM (MMS 2002-019 CD) and on the Internet (<http://www.mms.gov/alaska/cproject/liberty>).

FINAL

**OCEAN DISCHARGE CRITERIA
EVALUATION**

**IN SUPPORT OF THE LIBERTY
DEVELOPMENT PROJECT
NPDES PERMIT APPLICATION**

Prepared for
BP Exploration (Alaska), Inc.
P.O. Box 196612
Anchorage, Alaska 99519

November 1998

URS Greiner Woodward Clyde

URS Greiner Woodward Clyde
3501 Denali Street, Suite 101
Anchorage, Alaska 99503
986012NA

TABLE OF CONTENTS

List of Acronyms.....	iv
Section 1	Introduction.....1-1
1.1	Purpose of Evaluation - Determination of Degradation of Marine Waters..... 1-1
Section 2	Composition and Quantities of Materials Discharged.....2-1
2.1	Introduction2-1
2.2	Types of Discharges2-1
2.2.1	Facility Effluent Discharges - Outfalls 001 and 0022-1
2.2.2	Facility Construction Dewatering - Outfall 006.....2-4
Section 3	Transport and Persistence of Materials Discharged3-1
3.1	Introduction3-1
3.2	Overview of Project Site3-1
3.2.1	Bathymetry3-1
3.2.2	River Discharge.....3-1
3.2.3	Sea Ice3-2
3.2.4	Physical Oceanography3-2
3.2.5	Marine Water Quality.....3-4
3.3	Facility Effluent Discharges3-6
3.3.1	Construction Dewatering.....3-6
3.3.2	Continuous Flush System.....3-6
3.3.3	Desalination Unit Wastes3-6
3.3.4	Sanitary and Domestic Wastewater.....3-7
3.3.5	Seawater Treatment Plant (STP) Filter Backwash3-7
3.3.6	Fire Test Water.....3-7
3.3.7	Deck Drainage.....3-7
3.4	Effluent Dispersion Modeling for Facility Discharges.....3-8
3.4.1	Dispersion Processes3-8
3.4.2	Data Requirements3-8
3.4.3	Computational Models3-9
3.4.4	Dilution Computations for Outfall 0013-9
Section 4	Composition of Biological Communities4-1
4.1	Introduction4-1
4.2	Overview of Marine/Estuarine Communities and Ecosystems4-1
4.2.1	Phytoplankton.....4-1
4.2.2	Zooplankton4-1
4.2.3	Epibenthos4-1
4.2.4	Benthic Infauna4-2
4.2.5	Boulder Patch Kelp Community4-2
4.2.6	Fish.....4-3
4.2.7	Marine Mammals4-3
4.2.8	Birds4-4
4.3	Threatened and Endangered Species4-4

TABLE OF CONTENTS

Section 5	Potential Biological Impacts of Discharges	5-1
5.1	Introduction	5-1
5.2	Biological Effects of Discharges	5-1
5.2.1	Outfall 001.....	5-2
5.2.2	Outfall 002.....	5-5
5.2.3	Outfall 006.....	5-5
5.3	Physical Effects of Discharges	5-5
5.4	Effects On Threatened and Endangered Species	5-6
Section 6	Commercial, Recreational, and Subsistence Harvests	6-1
6.1	Introduction	6-1
6.2	Commercial Harvests	6-1
6.3	Subsistence Harvests	6-1
6.4	Recreational Fishery	6-1
6.5	Effects of Waste Discharges.....	6-1
6.5.1	Commercial Harvest Effects	6-1
6.5.2	Subsistence Harvests Effects	6-1
6.5.3	Recreational Fishery Effects.....	6-3
Section 7	Coastal Zone Management and Special Aquatic Sites	7-1
Section 8	Marine Water Quality Criteria and Water Quality Standards	8-1
8.1	Federal Standards	8-1
8.1.1	New Source Performance Standards	8-1
8.2	State Standards	8-2
8.3	Effects of Discharges.....	8-2
Section 9	Determination of Degradation of Marine Waters	9-1
9.1	Introduction	9-1
9.2	Determination.....	9-1
9.3	Monitoring Requirements	9-1
9.4	Conclusions	9-1
Section 10	References	10-1

TABLE OF CONTENTS

List of Tables

Table 2-1	Proposed Discharges From The Liberty Development Project
Table 3-1	Observed Water Column Structure Near Proposed Liberty Island Site
Table 3-2	Observed Current Velocities Near Proposed Liberty Island Site
Table 3-3	Comparison of Liberty Discharges with Ambient Conditions and Alaska Water Quality Criteria
Table 5-1	Water Quality Ranges For Organisms That May Be Encountered In The Vicinity Of Liberty Island
Table 5-2	Dilution Of Expected Contaminants In Effluent From Outfall 001
Table 5-3	Summary of Potential Stressor Effects
Table 8-1	Comparison Of U.S. EPA and State of Alaska Marine Water Criteria for Contaminants of Concern

List of Figures

Figure 1-1	Liberty Island Location Map
Figure 2-1	Liberty Development Seawater Process Line Diagram
Figure 3-1	Facility Plan
Attachment 1	Dilution Computations

LIST OF ACRONYMS

CMP	Alaska Coastal Management Program
AWQS	Alaska Water Quality Standards
BLM	Bureau of Land Management
BMPs	best management practices
BOD	Biological Oxygen Demand
BPXA	BP Exploration Alaska, Inc.
cfs	cubic ft per second
EOR	enhanced oil recover
EPA	U.S. Environmental Protection Agency
FAST System	Fixed Activated Sludge Treatment System
FEIS	Final Environmental Impact Statement
gpd	gallons per day
gpm	gallons per minute
mg/L	milligrams per liter
MLLW	mean lower low water
MMS	U.S. Minerals Management Service
MPI	Main Production Island
NMFS	National Marine Fisheries Service
NPDES	National Pollutant Discharge Elimination System
NSB	North Slope Borough
NSPS	New Source Performance Standards
NTU	nephelometric turbidity units
OCS	Outer Continental Shelf
ODCE	Ocean Discharge Criteria Evaluation
ppb	part per billion
ppm	parts per million
RCRA	Resource Conservation and Recovery Act
STP	seawater treatment plant
TRC	total residual chlorine
TSS	total suspended solids
USACE	U.S. Army Corps of Engineers

1.1 PURPOSE OF EVALUATION - DETERMINATION OF DEGRADATION OF MARINE WATERS

BP Exploration (Alaska), Inc. (BPXA) has applied for a National Pollutant Discharge Elimination System (NPDES) permit to discharge process wastewaters from the proposed Liberty Development Project. BPXA plans to develop the Liberty oil field in the Beaufort Sea for production and transport of sales-quality oil to the Trans-Alaska Pipeline System. The field will be developed from a gravel island constructed on the federal Outer Continental Shelf (OCS) in Foggy Island Bay. The proposed development includes construction of a gravel island and a subsea pipeline system from the proposed Liberty Island to a land-based connection with the Badami Pipeline.

Under Section 403 of the Clean Water Act, the NPDES permit for the Liberty Project must be issued in accordance with guidelines for determining the degradation of the territorial seas, the contiguous zone, and the oceans. These guidelines, referred to as the Ocean Discharge Criteria (40 CFR Part 125, Subpart M), and Section 403 are intended to “prevent unreasonable degradation of the marine environment and to authorize imposition of effluent limitations, including a prohibition of discharge, if necessary, to ensure this goal” (45 Federal Register 65942, October 3, 1980).

“Unreasonable degradation of the marine environment” is defined in 40 CFR 125.121(e) as:

- (1) Significant adverse changes in ecosystem diversity, productivity and stability of the biological community within the area of discharge and surrounding biological communities
- (2) Threat to human health through direct exposure to pollutants or through consumption of exposed aquatic organisms
- (3) Loss of esthetic, recreational, scientific or economic values which is unreasonable in relation to the benefit derived from the discharge
- (4) Determination of whether the discharge will result in unreasonable degradation is made after consideration of the following (40 CFR 125.122): quantities, composition, and potential for bioaccumulation or persistence of the pollutants to be discharged
- (5) The potential transport of such pollutants by biological, physical or chemical processes
- (6) The composition and vulnerability of the biological communities which may be exposed to such pollutants, including the presence of unique species or communities of species, the presence of species identified as endangered or threatened pursuant to the Endangered Species Act, or the presence of those species critical to the structure or function of the ecosystem, such as those important for the food chain
- (7) The importance of the receiving water area to the surrounding biological community, including the presence of spawning sites, nursery/forage areas, migratory pathways, or areas necessary for other functions or critical stages in the life cycle of an organism
- (8) The existence of special aquatic sites including, but not limited to marine sanctuaries and refuges, parks, national and historic monuments, national seashores, wilderness areas and coral reefs

- (9) The potential impacts on human health through direct and indirect pathways
- (10) Existing or potential recreational and commercial fishing, including finfishing and shellfishing
- (11) Any applicable requirements of an approved Coastal Zone Management plan
- (12) Such other factors relating to the effects of the discharge as may be appropriate
- (13) Marine water quality criteria developed pursuant to section 304(a)(1).

The United States Environmental Protection Agency (EPA) evaluation of these factors leads to one of three possible determinations and permit decisions. If the Regional Administrator determines that the discharge will not cause unreasonable degradation of the marine environment, an NPDES permit containing appropriate effluent limitations and monitoring requirements may be issued. If it is determined prior to permit issuance that the discharge will cause unreasonable degradation of the marine environment after application of all possible permit conditions, an NPDES permit may not be issued which authorizes the discharge of pollutants. If the Regional Administrator has insufficient information to determine prior to permit issuance that there will be no unreasonable degradation of the marine environment, there shall be no discharge of pollutants into the marine environment unless the Regional Administrator, on the basis of available information, determines in accordance with 40 CFR 125.123(c) that:

- (1) Such discharge will not cause irreparable harm to the marine environment during the period in which monitoring is undertaken, and
- (2) There are no reasonable alternatives to the on-site disposal of these materials, and
- (3) The discharge will be in compliance with all permit conditions including monitoring requirements and effluent limitations based on toxicity and biological impact of the discharged material (40 CFR 122.123[d]).

"Irreparable harm" as defined under 40 CFR 125.121(a) means significant undesirable effects occurring after the date of permit issuance which will not be reversed after cessation or modification of the discharge.

"No reasonable alternatives" means: No land-based disposal sites, discharge point(s) within internal waters, or approved ocean dumping sites within a reasonable distance of the site of the proposed discharge, the use of which would not cause unwarranted economic impacts on the discharger, or, notwithstanding the availability of such sites, on-site disposal is environmentally preferable to other alternative means of disposal after consideration of the relative environmental harm of disposal on-site, in disposal sites located on land, from discharge point(s) within internal waters, or in approved ocean dumping sites; and the risk to the environment and human safety posed by the transportation of the pollutants.

1.2 DESCRIPTION OF THE LIBERTY DEVELOPMENT PROJECT

The purpose of the Liberty Development Project is to develop the Liberty oil field in the Beaufort Sea for production and transport of sales-quality oil to the Trans-Alaska Pipeline System. The

field will be developed from an artificial gravel island constructed on federal OCS oil and gas lease OCS-Y-1650 (Sale 144) in Foggy Island Bay.

The Liberty oil field is located approximately 5 miles offshore in Foggy Island Bay (Figure 1-1). The proposed island site is located between the McClure Islands and the coast in water depths of about 22 feet (ft). The lead permitting agency is the U.S. Minerals Management Service (MMS) because the island is located in federal waters, and thus, MMS has jurisdiction over nearly the entire scope of the development, including construction, drilling, and operation. Other federal, state, and local agencies will also review and approve aspects of the project. The proposed transportation corridors linking Liberty to existing infrastructure will cross State of Alaska (State) lands, and thus will require State and North Slope Borough (NSB) authorizations. In addition, some supporting infrastructure will be constructed onshore, also requiring State and NSB approvals.

The proposed Liberty Development includes the following elements:

- Construction of an artificial gravel island approximately 1.5 miles west of Tern Island in Foggy Island Bay
- Placement of drilling, infrastructure, and processing facilities on the island
- Production of sales quality oil for export
- Potential production of product for export
- Disposal of drilling and other wastes on the island via permitted injection wells
- Transportation of sales quality oil from the production island via a buried subsea pipeline to a land-based connection with the Badami Sales Oil Pipeline
- Transportation of product via a buried subsea pipeline to a land-based connection with the Badami Products Pipeline
- Material and personnel necessary to construct and operate the Liberty Development Project
- Development of a gravel mine site.

1.3 SCOPE OF EVALUATION

This document, the Ocean Discharge Criteria Evaluation (ODCE), evaluates the proposed discharges from the Liberty Development Project with respect to the Clean Water Act Section 403(c) Ocean Discharge Criteria. The final project design will depend on permits issued by the U.S. Army Corps of Engineers (USACE) to discharge dredged or fill material (Section 404 of the Clean Water Act) and for structures or work in or affecting navigable waters of the U.S. (Section 10 of the River and Harbor Act of 1899).

The information required to address the criteria listed in 40 CFR 125.122 is derived primarily from four sources:

- ODCE documents for other areas of the Beaufort Sea under jurisdiction of EPA Region 10, i.e. the ODCE contained in the *Final Environmental Impact Statement (FEIS) for OCS Lease Sale 144* (MMS 1996) and *Endicott Development Project ODCE* (EPA Region 10, 1986)

- *Endicott Environmental Monitoring Program Final Reports 1985-1990* (USACE 1987-992)
- *Liberty Development Project Environmental Report* (LGL et al. 1998)
- *Liberty Development Final NPDES Permit Application* (BPXA 1998).

1.4 ORGANIZATION OF EVALUATION

For the purposes of this evaluation, the criteria listed in 40 CFR 125.122 have been consolidated into the following seven discussions, each of which is evaluated in a separate section of this document:

1. Composition and Quantities of Materials Discharged (Section 2)
2. Transport and Persistence of Materials Discharge (Section 3)
3. Composition of Biological Communities (Section 4)
4. Potential Biological Impacts of Discharges (Section 5)
5. Commercial, Recreational, and Subsistence Harvests (Section 6)
6. Coastal Zone Management and Special Aquatic Sites (Section 7)
7. Marine Water Quality Criteria And Water Quality Standards (Section 8)

The concluding section, Determination of Degradation of Marine Waters (Section 9), presents the overall determination of the EPA with respect to degradation of the marine environment.

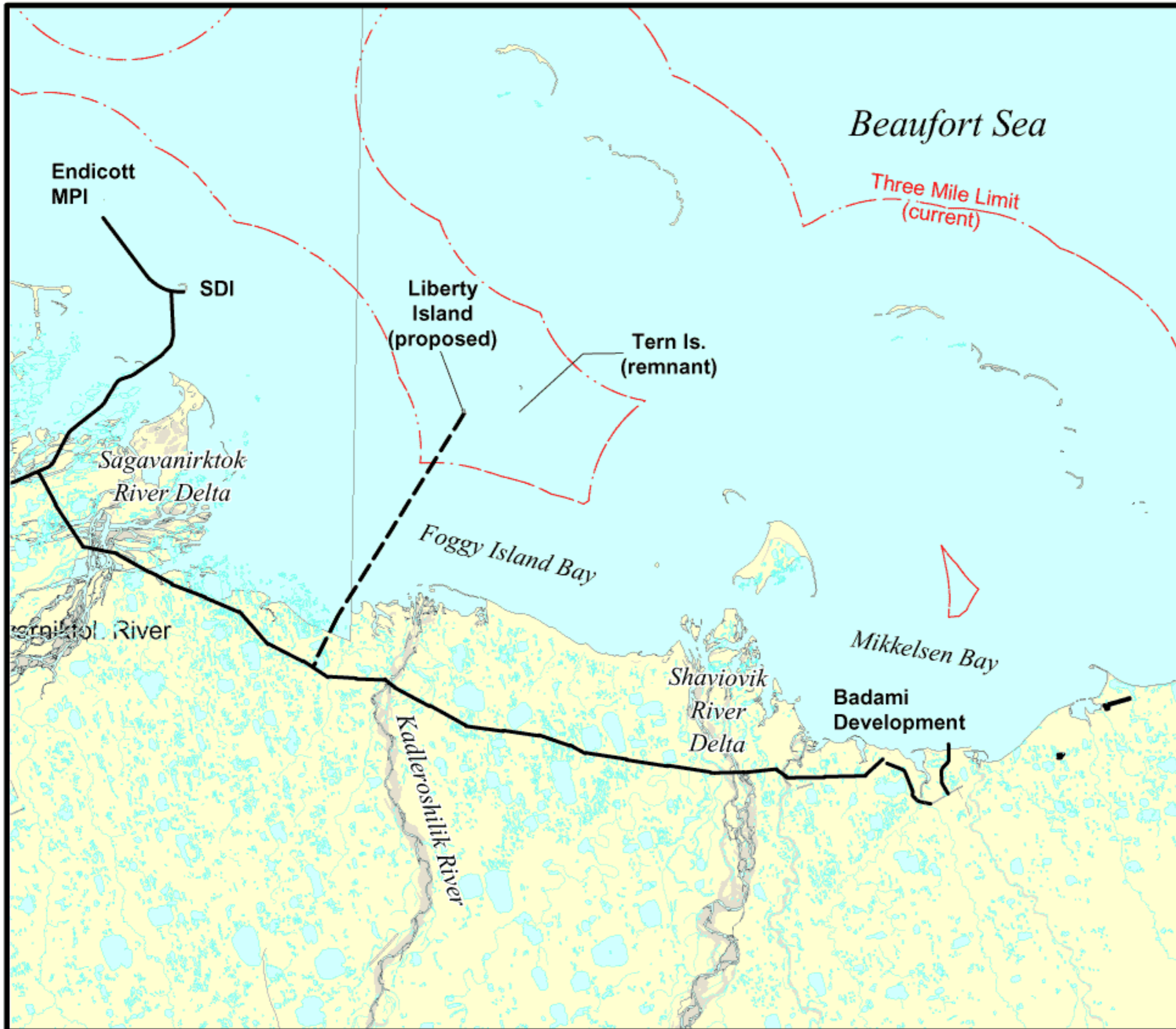

FIGURE 1-1

LIBERTY ISLAND LOCATION MAP



Scale (Statute Miles)
0 1 2 3 4

Legend:

- · - · - 3-mile Limit
- Proposed Liberty Pipeline Route
- Other Pipelines

Data Sources:
BPXA Cartography
USGS Topography Maps

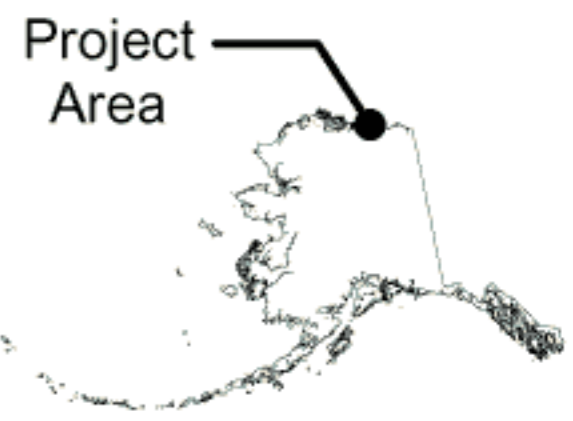

2.1 INTRODUCTION

Oil and gas development operations can produce a wide range of wastewater discharges related to drilling and production processes, equipment maintenance, and personnel facilities. The proposed discharges from the Liberty Development Project are listed in Table 2-1 and described below. A process flow diagram which shows an overview of the flows through the facility is presented in Figure 2-1. A detailed description of the composition and quantities of materials to be discharged is presented in the Liberty Development Project NPDES permit application (BPXA 1998A). Three outfalls are proposed for permitting: Outfall 001 will discharge facility process effluents, Outfall 002 will discharge fire test waters, and Outfall 006 will be a temporary discharge due to construction dewatering. These outfalls are not numbered sequentially since Outfalls 003, 004 and 005 were removed by the applicant after submittal of the permit application. A summary of the information contained in the NPDES permit application is given below.

2.2 TYPES OF DISCHARGES

The following discharges will be permitted under the Liberty Development Project NPDES permit:

- Facility Process Effluents including:
 - ♦ Continuous Flush System Discharge
 - ♦ Desalination Unit Wastes
 - ♦ Sanitary and Domestic Wastewater
 - ♦ Seawater Treatment Plant Filter Backwash
- Fire Test Water
- Facility Construction Dewatering

A description of each discharge is given below. A discussion of the disposition of deck drainage is also provided.

2.2.1 Effluent Discharges - Outfall 001

Outfall 001 is located on the south face of Liberty Island at a depth of 15 ft (5 m) MLLW. The discharge from the 2-in. (5 cm) nozzle is thus directed to the south and issues horizontally from the nozzle.

2.2.1.1 Continuous Flush System Discharge - Outfall 001(a)

A constant flow of chlorinated seawater will be drawn through the process water system to prevent ice formation and blockage in the effluent waste lines connected to marine Outfall 001. It is estimated that minimal amounts of total residual chlorine (TRC) will be consumed in the water passing through the Continuous Flush System. Using the most conservative assumption that no chlorine will be consumed, the target residual chlorine concentration to reach the

dechlorinator will be 0.2 parts per million (ppm). Prior to ocean discharge, this waste stream will be commingled and dechlorinated with the desalination unit wastes, seawater treatment plant (STP) filter backwash, and any temporary discharge of sanitary and domestic wastewater effluent as illustrated in Figure 2-1.

The temperature increase attributed to heat transfer from process water equipment (e.g., pumps, piping, etc.) is nominal ($\leq 1.0^{\circ}\text{C}$) for the Continuous Flush System waste stream (BPXA 1998). In addition to temperature, the physical properties of interest in the Continuous Flush System are pH and Total Suspended Solids (TSS). Chlorine in the form of calcium hypochlorite will be introduced into the effluent to reduce equipment biofouling. Prior to discharge, the Continuous Flush System waste stream will be commingled with the desalination unit wastes, STP filter backwash, and the temporary discharge of sanitary and domestic wastewater treatment effluent. Sodium metabisulfite will be injected into the commingled stream to reduce TRC concentrations to acceptable regulatory limits for marine water quality. The effluent pH will vary slightly from ambient conditions as a result of the chlorination/dechlorination process; however, the pH is expected to vary no more than 0.1 pH units from ambient.

2.2.1.2 Desalination Unit Wastes- Outfall 001(b)

The potable water treatment system uses a vapor compression (thermocompression) technology to generate water suitable for human consumption. The excess feed water that does not evaporate (blowdown) contains concentrated dissolved solids and salts (brine) near twice the concentration of ambient seawater. The resulting brine blowdown will be routed to marine Outfall 001. Continuous injection of maintenance chemicals including scale control additives and foamer, which are safe for drinking water, will be added during the process. Periodic injection of sulfuric or sulfamic acids will remove mineral buildup in the desalination facility. Chlorine that enters the desalination unit will be off-gassed and vented into the atmosphere. Thus it is expected that the desalination blowdown or brine will not contain residual chlorine.

The engineering specifications provided by the manufacturer indicate the effluent will have a temperature increase of 5°C to 7°C over ambient conditions. The manufacturer determined that total dissolved solids would increase to 65 to 70 parts per thousand (‰) for ambient seawater containing 36‰. It is expected that the desalination unit wastes will have salinity between 60‰ and 65‰.

2.2.1.4 Sanitary and Domestic Wastewater - Outfall 001(c)

All domestic and sanitary waste will pass through the wastewater treatment system. Secondary treatment of the domestic sewage will be accomplished using a D-series FAST[®] System (Fixed Activated Sludge Treatment). A disinfectant system using ultraviolet (UV) light will be placed in the discharge stream between secondary treatment and final disposal. Typically, the wastewater stream will be injected into the permitted disposal well. However, during facility construction and periods when the disposal well is not available, the wastewater treatment plant effluent will be commingled with the STP filter backwash, continuous flush, and desalination unit waste streams. The resulting commingled stream will be dechlorinated via the addition of a sodium metabisulfite solution prior to marine discharge.

Sludge resulting from the secondary treatment will be injected into the on-site disposal well. In the event that the disposal well is not available, the sludge will be disposed of onshore at an approved facility within the Prudhoe Bay area.

2.2.1.5 Seawater Treatment Plant (STP) Filter Backwash - Outfall 001(d)

Backwash from the strainer and hydrocyclone will have an elevated TSS concentration, dependent on TSS concentrations at the seawater intake. The flow will be commingled with the continuous flush effluent, desalination unit wastes and any temporary discharge of sanitary and domestic wastewater to Outfall 001. This waste stream will be discharged through the outfall after passing through the dechlorination process.

Heat will be added to the remaining seawater, some of which will be routed to the seawater intake as required to prevent ice formation. The remaining process seawater will be deaerated. Biocide, anti-foam agent, scale inhibitor, and corrosion inhibitor will be added to this fluid stream which will then be routed to the enhanced oil recover (EOR) wells for injection. Since the biocide, antifoam agent and scale and corrosion inhibitors are added downstream of the backwash flow, these additives will be injected into the geologic formation along with the seawater, and will not be discharged into the marine environment.

Natural variability of TSS determines variability of the TSS discharge. In the summer when TSS is high, the TSS discharges will be high; and in winter when the TSS is low, the TSS discharge will also be low. Summer STP filter backwash is expected to have average daily TSS concentrations of 4,600 mg/L with maximum concentrations of 28,000 milligrams per liter (mg/L). Average daily concentrations in the winter are expected to be 780 mg/L with maximum levels of 1,600 mg/L.

2.2.2 Fire Test Water - Outfall 002

While there typically will be no continuous flow, the fire water distribution system will provide emergency seawater supply throughout the Liberty Production Facility to suppress and extinguish fires. This system is designed to pump up to 2,500 gpm of seawater from the seawater intake sump through a header and distribution system to sprinklers, hydrants, monitors, and deluge valves. Fresh potable water (pack water) will be supplied to maintain water pressure in the header and distribution lines. Weekly tests of the fire control pumps will circulate chemically untreated seawater from the seawater intake sump through the pumps and directly back in the seawater intake sump. The weekly tests are not expected to change the temperature or other physical properties of the seawater from ambient.

2.2.3 Deck Drainage - Outfalls 003, 004, 005

This facility has been designed to eliminate deck drainage discharges into the marine environment; therefore the deck drainage outfalls have been removed.

To prevent accidental discharges of spilled chemicals or petroleum into the surface waters of Foggy Island Bay, a deck drainage and grading system will be installed to capture potential pollutants. Since Liberty Development is in the arctic marine environment, deck drainage sources include precipitation (e.g., snow, rain, etc.), storm waves, and sea spray. The facility will

incorporate best management practices (BMPs) to help prevent spills and leaks from entering the deck drainage collection system. Based on historical spill reports from the Endicott Main Production Island (MPI), the most likely fluid releases at the Liberty Development include:

- Equipment malfunctions (leaking valves and gaskets, ruptured hoses) typically caused by cold weather problems
- Fluid transfers (overfilling) typically caused by operator inattention
- Vehicles (fluid leaks) typically maintenance items

The onsite disposal well will be permitted as an industrial disposal well for non-hazardous and Resource Conservation and Recovery Act (RCRA)-exempt fluids. All fluids which collect in the sumps will be injected in the disposal well if they are non-hazardous or RCRA-exempt. Any fluids classified as RCRA-hazardous waste will be managed at a designated storage area pending shipment to an approved hazardous waste disposal facility.

2.2.4 Facility Construction Dewatering - Outfall 006

Water discharged during construction dewatering will consist of Beaufort Sea water that has percolated through the clean gravel fill and has collected in the excavation. Clean gravel fill used to construct the island will contain fines which may be subsequently discharged with the excavation water. A pump rated at no greater than 650 gallons per minute (gpm) will be used as required to dewater the construction trenches. The discharge hose will be placed under the ice (if present) into water adjacent to the island.

A new pipeline caisson design will replace the pipeline riser as illustrated in Exhibit 17 (page 41) of the Liberty Development Project NPDES Permit Application (BPXA 1998A). The revised design will use a pull-tube construction technique where a 36-inch pipe (casing) will be shaped and installed as a conduit from the production island surface to the subsea pipeline grade. The casing will be approximately 200 to 300 feet long and installed as a single piece. No construction dewatering will be required for placement of the 36-inch casing. Seawater will enter the casing since the subsea pipeline grade is below sea level. The design engineers do not envision the need to pump seawater during construction or placement of the 36-inch casing.

There will be two subsea pipelines with diameters of 12-inches and 6-inches that will be bundled together. Once the pipeline construction reaches the production island, a wire rope will pull the subsea pipelines through the 36-inch casing. It is anticipated that no dewatering will be required during this construction.

TABLE 2-1
Proposed Discharges From the Liberty Development Project

OUTFALL	DISCHARGE TYPE	AVERAGE FLOW (GPD)	MAXIMUM FLOW (GPD)
001	Continuous Flush System	21,600	21,600
001	Potable Water Desalination System Brine Blowdown	40,320	57,600
001	Sanitary and Domestic Wastewater	9,072	10,080
001	Seawater Treatment Plant Backwash	22,118	22,118
002	Fire Test Water	Typically No Flow	2,500
006	Construction Dewatering	1,000,000	1,000,000

NOTE: Due to design changes, Outfalls 003, 004, and 005 were removed by the applicant after submittal of the permit application

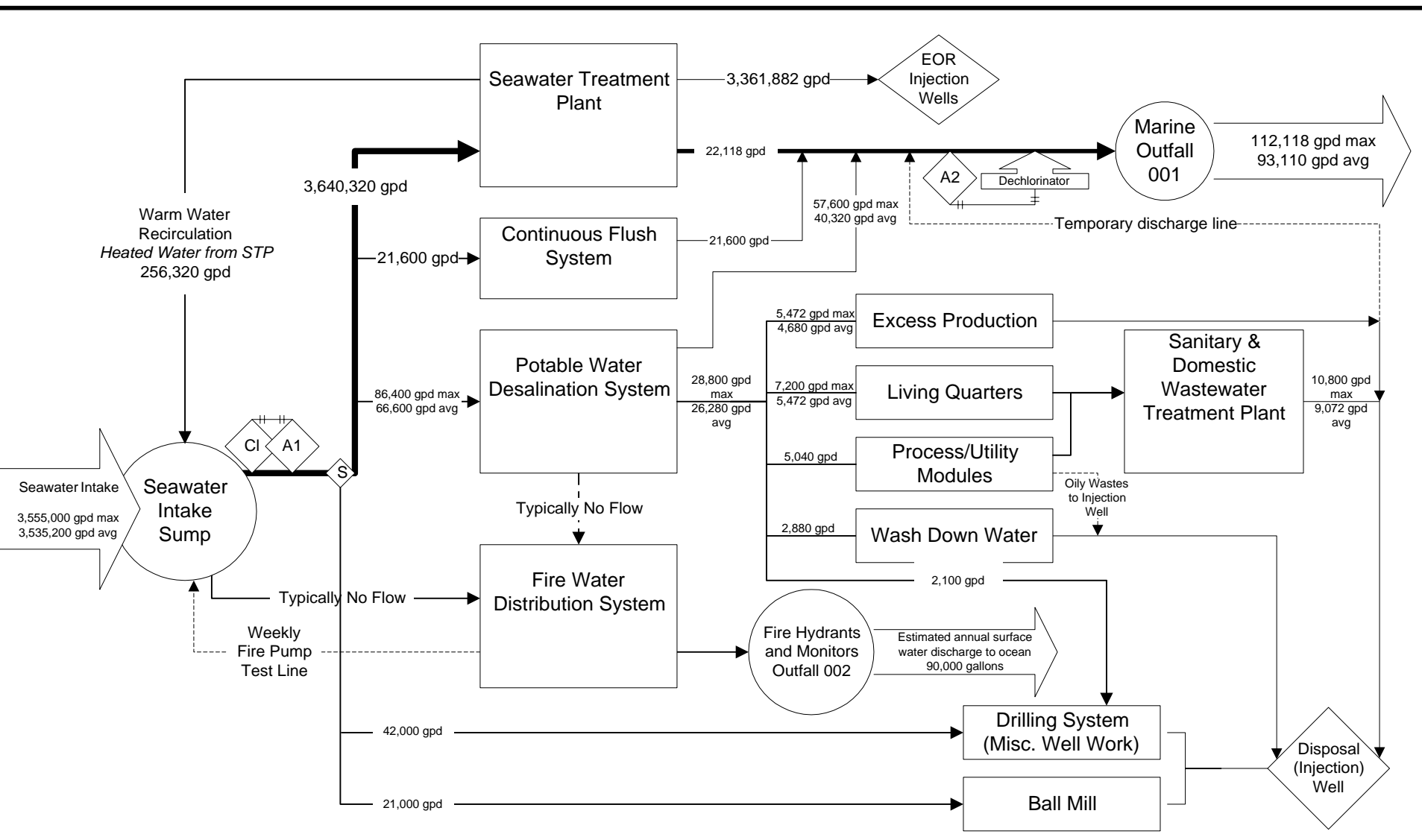

Notes:
 gpd = gallons per day
 gpm = gallons per minute
 A# = online residual chlorine analyzer with designated Unit #
 CI = system chlorinator using Ca(OCl)₂
 Wash down water will not be discharged through a marine outfall.
 S = strainer

BP Exploration (Alaska) Inc.
 Liberty Development
 Seawater Process Line Diagram
 Figure 2-1

3.1 INTRODUCTION

A number of factors influence the transport, fate, and persistence of discharges associated with the Liberty Project. These factors include the depth of the discharge, means of disposal, discharge rate, and oceanographic characteristics of the receiving waters. Sections 4.4 and 4.5 of the *Liberty Development Environmental Report* (LGL et al. 1998) describe in detail the oceanography and marine water quality of the area. This source, along with the *Final Environmental Impact Statement (FEIS) for Lease Sale 144* (MMS 1996), the *Liberty Development NPDES Permit Application* (BPXA 1998), and the *Endicott Environmental Monitoring Program* (USACE 1985-1990) provides references for the information presented herein.

3.2 OVERVIEW OF PROJECT SITE

3.2.1 Bathymetry

The location of the proposed artificial island is north of the Kadleroshilik River delta and immediately seaward of the 20-ft isobath within Foggy Island Bay. Foggy Island Bay is a shallow embayment, with shoals evident in nearshore areas. In the eastern half of the bay, the sea floor is very shallow, such that the 10-ft isobath is about 2.5 miles from shore. Seaward of the 10-ft isobath, the sea floor exhibits a gradual uniform slope to the 20-ft isobath. The sea floor in the western half of the bay is similarly shallow. The steepest bottom slopes in Foggy Island Bay are located immediately off the Kadleroshilik River delta, where the 5-ft isobath lies less than 1 mile offshore and the 10-ft isobath is about 1.5 miles offshore. At the far east end of the bay, a half-mile wide, shallow (3 ft deep) channel separates Tigvariak Island from the mainland.

3.2.2 River Discharge

Three streams provide freshwater input into Foggy Island Bay:

- Western tributaries of the Shaviovik River
- Kadleroshilik River
- East Channel of the Sagavanirktok River

From its headwaters in Juniper Creek to the coast, the Shaviovik River is about 100 miles long with a drainage area of about 1,700 square miles. The discharge of the Shaviovik River is seasonal, annually averaging 800 cubic ft per second (cfs) with discharge ceasing in late fall as the river freezes (AEIDC 1974).

The Kadleroshilik River discharges directly into the middle of Foggy Island Bay. This river is 75 miles long, has a drainage area of about 650 square miles and an average annual flow of 325 cfs. The Sagavanirktok River has an annual average flow of 2,770 cfs (AEIDC 1974). Approximately 3 percent of the Sagavanirktok River flow, or 83 cfs, discharges through a minor east channel into Foggy Island Bay (USACE 1994). While the larger Sagavanirktok and Shaviovik rivers are prone to summer floods resulting from thunderstorms in the Brooks Range,

the Kadleroshilik River is not prone to summer flooding since the watershed is smaller and is restricted to the Arctic Coastal Plain.

3.2.3 Sea Ice

The proposed island is located in 22 ft deep water inside the barrier islands. This is within the land-fast ice zone that extends from the shore out to the zone of grounded ridges in 26 to 50 ft of water. In late winter, first-year sea ice in the Beaufort Sea is generally about 6.5-ft thick; from the shore to a depth of 6.5 ft, the ice is frozen to the bottom, forming the bottom-fast ice zone. The remaining ice in the land-fast ice zone is floating. Onshore movement of the floating ice is relatively common and generates pileups and rideups along the coast and on offshore structures and barrier islands.

Sea ice forms within Foggy Island Bay in September or October, typically alongshore where water is less saline. Initially, the water is covered with brash (floating slush) and pancake ice (small, thin patches) which gradually thicken into ice sheets. If storm surges occur during the early stages of freezeup, the smooth sheet of ice can be broken into blocks, forming a chaotic mass of ice. As the sea ice develops, the ice blocks freeze into an ice sheet which grows to a thickness of about 6.5 ft by April or May. Ice blocks within the sheet may extend to 13 ft below the surface.

Breakup of the sea ice in the western portion of Foggy Island Bay is initiated by the overflow of freshwater discharge from the Sagavanirktok River. The overflow covers the sea ice adjacent to the distributary delta, eventually melting the affected ice. As the air temperature rises above freezing, the nearshore landfast ice detaches from the bottom and melts, leaving a nearshore band of open water. This process elevates ambient suspended sediment as the seafloor material which was incorporated into the bottom of the ice melts into the water column. As sea ice melting continues, the remaining ice in the bay is floating. Wind-generated currents move and breakup the ice cover, resulting in a westward alongshore movement corresponding to the prevailing current.

3.2.4 Physical Oceanography

The Beaufort Sea has been studied intensively for nearly two decades, so the oceanographic behavior of the region is well-understood. As with the Beaufort, the water dynamics within Foggy Island Bay are governed by recent wind history, and proximity and volume of freshwater sources. Other factors that influence oceanographic conditions include air temperature, precipitation, bathymetry, earth rotation (Coriolis effect), and sea ice cover.

3.2.4.1 Summer Conditions (Open-Water)

Information presented herein is derived from *Endicott Environmental Monitoring Program Final Reports* (USACE 1987-1994). During the summer open-water season, the timing and rate of discharges from the Sagavanirktok, Kadleroshilik, and Shaviovik rivers determine the amount of freshwater available for distribution in the marine environment of Foggy Island Bay. The first open water typically occurs in late June to early July and, as warming continues into summer, the sea ice melts, resulting in about 75 days of open water. After sea ice breakup, wind speed and

direction become the key factors in determining the fate of freshwater advected along the coast. Wind speed and direction also influence water level variations that, in turn, play a key role in the exchange rates between brackish nearshore and offshore marine waters. Other agents controlling currents include the small (<12 inches) astronomical tide and occasionally large 3- to 7-ft storm surges and, much more locally, river discharge adjacent to river deltas.

The Sagavanirktok River delta, located immediately west of Foggy Island Bay, discharges substantial volumes of freshwater into the nearshore environment. A small distributary of the Sagavanirktok River empties into the embayment along the western shore. During and immediately after sea ice breakup, there is a freshwater (~3 to 6 ‰) surface layer up to 12 ft thick that encompasses the bay and covers the marine (~30 ‰) waters. This two-layer or stratified water column is a short-term event, persisting on average for only 1 or 2 weeks. As the sea ice diminishes, winds mix the waters of Foggy Island Bay, creating an unstratified (uniform) water column of brackish (~12 to 17 ‰) waters. As summer progresses, the water column typically remains unstratified, with salinity gradually increasing to marine (>30 ‰) conditions by mid-September. These unstratified marine conditions persist into freezeup.

Wind history (speed and direction) is of prime importance in determining the fate of freshwater advected along the coast by currents during the open-water season. The prevailing summer winds along the Beaufort Sea coast are from the east, so the nearshore currents respond to this wind stress by flowing westward. This current regime transports river discharges westward alongshore such that freshwater is mixed with the ambient nearshore waters.

Two scenarios permit the temporary formation of a stratified water column within Foggy Island Bay: 1) upwelling of marine bottom waters, and 2) sufficient freshwater discharge during westerly winds. Under strong easterly winds, regional coastal upwelling draws cold, saline, bottom water into the nearshore environment. This results in a temporary stratified, two-layer water column consisting of brackish (~20 ‰) surface waters and a bottom layer of cold, saline (>30 ‰) waters. When sufficient freshwater enters Foggy Island Bay and mixes with the upper portion of the water column, a surface layer forms that has lower salinities than the underlying waters.

During easterly winds, the freshwater plume is restricted to the shallow nearshore waters and flows out of Foggy Island Bay, around Point Brower and toward the west. Thus, the freshwater discharge does not mix with the waters of Foggy Island Bay, with the exception of a narrow band of nearshore water immediately adjacent to the western shore. However, during westerly winds, the freshwater plume mixes with the surrounding bay waters, creating a stratified water column.

Sea ice is prevalent throughout the central Beaufort Sea during early summer (June to mid-July), limiting wind stress applied to the water column. The average current speed during June and July is only about 0.04 knots (kt) [5 centimeter/second (cm/s)]. As the open-water season progresses, and the area is freed of large concentrations of sea ice, the water surface is more exposed to the prevailing winds. Then the average current speed (August-September) is about 0.3 kts (14 cm/s) with a maximum observed speed of 1.3 kts (68 cm/s).

3.2.4.2 Winter Conditions (Ice-Covered)

During winter, the Beaufort Sea is covered by sea ice that begins to form in late September. Freezup of the waters is completed by the end of October, with ice growing to a maximum thickness of 2.3 m (7.5 ft) by April (MMS 1996). Ice cover persists on average for 290 days until spring warming results in river breakup, and subsequent sea ice melting near the river and stream deltas. Temperature and salinity profiles collected under the sea ice within the Beaufort Sea exhibit uniform cold, 29°F (-1.5°C), saline (32.4‰) marine waters (Montgomery Watson 1997, 1998). Under ice observations in the Beaufort Sea indicate very low current speeds aligned with bathymetry, which results in an easterly or westerly flow. The average current speed observed during ice-covered conditions is less than 0.04 kt (2 cm/s) (Montgomery Watson 1997).

While the current meters employed during under-ice studies are generally insensitive to speeds below 0.04 kts (2 cm/s), the data do not indicate stagnant conditions. Heavy brine formed by the thickening sea ice could produce a stratified water column in stagnant or near-stagnant conditions; however, low current speeds (e.g., less than 2 cm/s) are sufficient to disperse any such brine through the water column and minimize or eliminate resulting under-ice vertical stratification. The typical water column structure observed under sea ice in the Beaufort Sea is uniform, with no temperature, salinity, or density stratification.

3.2.5 Marine Water Quality

3.2.5.1 Salinity and Temperature

Marine waters are generally cold, -2° to 5°C (28° to 41°F), and saline (28 to 30 ‰) (Craig 1984; Colonell and Niedoroda 1990). Temperature and salinity within the central Beaufort Sea nearshore zone are strongly influenced by the prevailing summer wind velocity (direction and speed), the proximity of freshwater discharge by coastal river systems, and the presence of sea ice.

Data from the Endicott monitoring program show that, during open-water conditions under east winds, flow in the bay is directed toward the northwest, generally aligned with the bathymetry (USACE 1987). Thus, fresh water discharged from the Sagavanirktok River moves north and around the tip of Point Brower. Under westerly winds, fresh water from the east channel of the Sagavanirktok River mix with the surface waters of Foggy Island Bay, forming a brackish water surface layer (Woodward-Clyde 1998b). Typically, this brackish surface layer increases in salinity toward the east, and away from the source of fresh water.

In February 1997 and March 1998, Montgomery Watson collected salinity and temperature measurements under the ice in the vicinity of the proposed pipeline route for the Liberty Development Project. Under-ice water temperatures ranged from -2° to 0°C (28° to 32°F), with salinity ranging from 17 to 33‰. Ice thickness at the stations ranged from 3 to 5.3 ft, with total ice-free water depths of 0.3 to 16.7 ft (Montgomery Watson 1997, 1998).

3.2.5.2 Dissolved Oxygen

During the open-water season, dissolved oxygen levels in Foggy Island Bay are usually high, typically above 10 mg/L (Woodward-Clyde 1998b). During open water, the highest dissolved oxygen concentrations occur in the colder, more saline water located near the bottom of the water column (Woodward-Clyde 1981). Under winter ice-cover, respiration by planktonic and other organisms continues, but atmospheric exchange and photosynthetic production of oxygen cease. Throughout the ice-covered period, dissolved oxygen concentrations in areas with unrestricted circulation seldom drop below 6 mg/L. Under-ice dissolved oxygen concentrations in February 1997 and March 1998 along the proposed Liberty pipeline route ranged from 7.4 to 13.2 mg/L (Montgomery Watson 1997, 1998).

3.2.5.3 Turbidity and Suspended Sediment

Suspended sediment is introduced naturally to the marine environment through river runoff and coastal erosion (MMS 1996) and is resuspended during summer by wind and wave action. Satellite imagery and suspended particulate matter data suggest that turbid waters are generally confined to depths less than 16 ft (5 meters) and are shoreward of the barrier islands. In mid-June through early July, the shallow nearshore waters generally carry more suspended sediment as a result of increased sediment load discharged from the rivers (Sagavanirktok, Kadleroshilik and Shaviovik), and thus, very high turbidity is observed adjacent to the river mouths. Storms, wind and wave action, and coastal erosion increase turbidity in shallow waters periodically during the open-water season. Turbid conditions persist in areas where the sea floor consists primarily of silts and clays as compared to areas having a predominately sand bottom.

Suspended sediment concentrations are governed primarily by wind-induced waves and freshwater input from the Sagavanirktok River and other major rivers (USACE 1987). Britch et al. (1983) found peak suspended sediment concentrations were associated with intervals of highest significant wave heights. The 1983 study reported a maximum TSS value of 324 mg/L at a nearshore station and an average of 45 mg/L. During the 1998 open-water season, the average TSS value was 30 mg/L, similar to the 1983 study (Woodward-Clyde 1998b). In-situ turbidity measurements collected during the 1998 open-water season ranged between 1 and 173 nephelometric turbidity units (NTU). There was no correlation between TSS and turbidity values from samples collected within Foggy Island Bay (Woodward-Clyde 1998b).

The presence of ice cover limits wave action resulting in decreased turbidity (MMS 1996). Under-ice TSS values along and in the vicinity of the proposed Liberty pipeline route ranged from 2.5 to 76.5 mg/L (Montgomery Watson 1997, 1998); field-measured turbidity for February and March under-ice conditions ranged from 1 to 35.6 NTU, and laboratory-measured turbidity ranged from 0 to 24 NTU (Montgomery Watson 1997, 1998).

3.2.5.4 Nutrients

Nitrogen and phosphorous are introduced to Foggy Island Bay by river runoff and coastal peat erosion. Levels decline in the summer, after breakup, and are considered limiting by the end of summer (Bureau of Land Management [BLM] 1979). Schell (1982) found nitrogen availability limits most marine plant growth during most of the arctic summer season.

3.2.5.5 Trace Metals

Trace metals are introduced naturally to the central Beaufort Sea through river runoff (relatively unpolluted by humans), coastal erosion, atmospheric deposition, and natural seeps. Since there is little industrial discharge activity in this region, most trace metals concentrations are low in the Beaufort Sea (MMS 1996). Montgomery Watson collected under-ice water quality samples along the proposed right-of-way in 1998 (Montgomery Watson 1998). The samples were analyzed for arsenic, barium, chromium, lead, and mercury. Arsenic concentrations ranged from less than the minimum report detection limit of 0.002 mg/L to 0.0226 mg/L. Barium was detected at concentrations-- ranging from 0.0175 mg/L to 0.0551 mg/L. Chromium, lead, and mercury concentrations were below detection levels.

Open-water concentrations for arsenic, chromium, lead, and mercury were below detection limits (Woodward-Clyde 1998b). Barium concentrations were determined to range from 0.010 to 0.021 mg/L, with the distribution corresponding to the brackish surface waters associated with the Sagavanirtok River discharge.

3.2.5.6 Hydrocarbons

Background water hydrocarbon concentrations in the Beaufort Sea tend to be low, generally less than one part per billion (ppb), and appear to be biogenic.

3.3 FACILITY EFFLUENT DISCHARGES

3.3.1 Construction Dewatering

Discharge will be into the waters of the Beaufort Sea, directly into the waters adjacent to the island. The receiving water will already contain both suspended sediment that winnows from the island surface and sediment that is disturbed from the seafloor during trenching and excavation activities. The average daily flow rate into the seawater intake system and Outfall 001 excavations is estimated to be approximately 1,000,000 gallons per day (gpd) [650 gal/min x 60 min/hr x 24 hrs/day = 936,000 gal]. No construction dewatering will be required for placement of the 36-inch pipeline casing. Since dewatering of the seawater intake system and outfall will occur sequentially, a single pump is expected to be able to handle this discharge volume. The discharge location into water adjacent to the island will be designated as Outfall 006.

3.3.2 Continuous Flush System

A constant flow of 21,600 gpd of chlorinated seawater will be drawn through the system to prevent ice formation and blockage in the effluent waste lines connected to marine Outfall 001. Outfall 001 will be a 6-inch diameter HDPE pipe placed approximately 15 ft below MLLW (mean lower low water).

3.3.3 Desalination Unit Wastes

The resulting brine blowdown will be routed to marine Outfall 001 with an expected continuous average flow of 40,320 gpd and a maximum flow of 57,600 gpd.

3.3.5 Sanitary and Domestic Wastewater

The wastewater treatment plant will receive all of the domestic sewage and sanitary waste generated by the Liberty production facility. It is estimated that the maximum flow through the wastewater treatment plant will be approximately 10,080 gpd, with an average value flow of 9,072 gpd. The permitted disposal well is the primary disposal method; however, in the event that the disposal well is not available, the sanitary and domestic wastewater effluent will be diverted through marine Outfall 001.

3.3.6 Seawater Treatment Plant (STP) Filter Backwash

Approximately 3,640,320 gpd of seawater will enter the STPt; of this amount, 3,361,882 gpd will be injected into the reservoir as waterflood for EOR in the Liberty production field. Up to 256,320 gpd of warm water will be recirculated through the seawater intake to prevent ice formation. The flow from the filter backwash is expected to be 22,118 gpd and will be commingled with the continuous flush effluent, desalination unit wastes, and any temporary discharge of sanitary and domestic wastewater to Outfall 001. This waste stream will be discharged through the outfall after passing through the dechlorination process.

3.3.7 Fire Test Water

Annual testing will be conducted on the whole system such that seawater will be discharged through selected fire hydrants, monitors, and deluge valves to ensure adequate water pressure is available for fire control. Immediately prior to the annual test, the pack water containing chlorine will be flushed from the lines and disposed of through the onsite injection well. To assure that only chemically untreated seawater is discharged into the Beaufort Sea, the operators will flush the fire system header and distribution system with twice the volume of the header and distribution system. Consequently, no residual chlorine will be discharged into the marine environment. The annual test will discharge untreated seawater directly over the side of Liberty Island and directly onto the surface waters of the Beaufort Sea. It is anticipated that 75,000 gallons of chemically untreated seawater will be discharged for a 30-minute test period, with a maximum flow rate of 2,500 gpm.

3.3.8 Deck Drainage — No Discharge

This facility has been designed to eliminate deck drainage discharges into the marine environment; therefore the deck drainage outfalls (003, 004, and 005) have been removed.

In the event of a petroleum or chemical spill at the Liberty Development, all fluids collected in the deck drainage sumps will be evaluated for disposal and pumped either to the disposal well or to a designated storage area pending shipment to an approved hazardous waste disposal facility in the contiguous United States. There will be no routine discharge to the ocean from these sumps.

In the event of a large flow (upset condition), such as that caused by heavy rains or by waves overtopping the island during a severe storm, the sumps will not have adequate capacity to collect, store for inspection, and discharge the water being pumped to the disposal well or holding tank on a batch basis. In these cases, which are expected to be rare occurrences, the

sumps will overtop and flow over the side of the island to the ocean. The underflow baffle is designed to contain any floating oil in each sump.

3.4 EFFLUENT DISPERSION MODELING FOR FACILITY DISCHARGES

The Liberty Development Project will be located in federal waters approximately 1.4 miles north of the 3-mile state/federal waters boundary. As such, the facility will be required to meet federal water quality standards. Given the facility effluent discharges and the distance to state waters, the impacts to state waters is expected to be negligible. However, to be consistent with existing and proposed North Slope operations as they pertain to wastewater discharges, BPXA has elected to design the Liberty Development Project to meet the more stringent state water quality standards for all marine water supply uses [18 AAC 70.020(a)(2)]

3.4.1 Dispersion Processes

Mixing of the discharge from an outfall that is submerged in an aquatic environment occurs in two hydrodynamic zones: a “near-field” zone of intense mixing and a “far-field” zone of passive spreading and much less vigorous mixing. In the near-field, outfall geometry, initial effluent momentum and buoyancy control the mixing processes; in the far-field, the ambient environmental conditions control mixing.

The computational objectives of dispersion modeling are (1) to determine how near-field dilution of the effluent can be optimized through examination of various outfall configurations, and (2) to determine the maximum effluent dilution attainable in receiving waters with due consideration to the range of hydrographic conditions that might be experienced there.

Modeling for the Liberty Development was performed to determine if effluent from Outfall 001 will meet Alaska Water Quality Standards (AWQS) at the 3-mile state/federal waters boundary. The boundary is located 1.4 miles south of the proposed Liberty Island (see Figure 1-1). The continuous flush system discharge, desalination unit wastes, domestic waste water, and STP filter backwash are all combined and discharged through Outfall 001. The location of Outfall 001 is shown on Figure 3-1.

3.4.2 Data Requirements

Data requirements for analysis of the capabilities of a water body to dilute and disperse an effluent are of two types: hydrodynamic and hydrographic. Hydrodynamic data provide information on water movements; that is, current speed and direction of currents near the discharge point are necessary data for analysis of both near- and far-field effluent movements.

Hydrographic data provide documentation of water properties, with density being the property of immediate concern for the effluent dilution problem. Density is not measured directly but, rather, is computed as a function of water temperature, salinity (the concentration of dissolved solids), and pressure. Knowledge of the vertical density profile is essential for analysis of the near-field behavior of a discharge because the difference between ambient and effluent densities at outfall depth governs the initial buoyancy of the discharge.

3.4.3 Computational Models

CORMIX1, a system of computational models for the analysis of submerged single-port discharges, was used to perform the near-field dilution analysis for Outfall 001. CORMIX1 and its component algorithms were developed at Cornell University, under direction and sponsorship of the EPA (Doneker and Jirka 1990) and is typically used for this type of analysis.

CORMIX1 uses knowledge and inference rules based on hydrodynamic expertise to classify and predict buoyant jet mixing in a stratified or uniform density ambient environment. After reviewing input data that describe the discharge and receiving water, CORMIX1 checks for data consistency, and then identifies the discharge as one or more of 35 generic flow classifications that fall into three major categories: flows affected by linear stratification, buoyant flows in uniform ambient layers, and negatively buoyant flows. The classification of flow into one of the 35 classes is based upon length scales calculated from dimensional analysis, and proven by exhaustive laboratory studies to be accurate predictors of the various flow classes.

Once the given outfall flow has been assigned to a particular class by CORMIX1, the appropriate computational algorithm is applied, and the dilution is calculated. If more than one class is indicated (e.g. the discharge first rises as a buoyant plume and then is more strongly affected by ambient current), the model applies an intermediate solution to account for the transition between classes. Results of the computations enable prediction of effluent dilution as a function of distance from the outfall.

3.4.4 Dilution Computations for Outfall 001

Although not required, BPXA has elected to determine dilution computations to assure that all constituents of Outfall 001 will be adequately diluted. The largest dilution required for any flow from Outfall 001 is 43:1 to ensure that the average TSS of the effluent is reduced to within AWQS. According to AWQS (18 AAC 70.020), a permitted discharge in state waters must not cause the turbidity to exceed 25 NTU outside an approved mixing zone. For similar installations (e.g. Endicott Development), the criterion of 25 NTU has been interpreted as being approximately equal to 30 mg/l TSS.

Assuming an average ambient TSS concentration of 40 mg/L, the average TSS load in the combined desalination, domestic wastewater, and STP effluent was computed to be 1,281 mg/L. An effluent dilution of at least 43:1 (1,281/30) would be required to reduce the TSS concentration to 30 mg/l. Although a minimum dilution of only 43:1 is required, a larger “target” dilution of 50:1 was selected to ensure a small (conservative) margin for possible error in the computations. It is important to note that the summer receiving waters contains an ambient TSS 10 mg/L higher than the target concentration of 30 mg/L. CORMIX does not take into account the ambient TSS; therefore, the TSS concentration at the 50:1 dilution will be higher than 30 mg/L due to the presence of higher TSS concentrations in the receiving waters.

Outfall 001 is located on the south face of Liberty Island at a depth of 15 ft (5 m) MLLW. The discharge from the 2-in. (5 cm) nozzle is thus directed to the south and issues horizontally from the nozzle. Current direction along the south face of Liberty Island will be constrained to either east or west, and is assumed to have speeds in accordance with those listed in Table 3-3.

Since the effluent is composed of seawater with a minor temperature and salinity increase over ambient conditions, the discharge will behave essentially as a submerged negatively buoyant turbulent jet. The results indicate that the target dilution of 50:1 occurs within 6 m horizontally and within 1.5 m vertically of the outfall.

The coordinate distances X, Y, and Z are all measured from Outfall 001 and are defined as follows:

X = distance downstream from the outfall (i.e., east or west, depending on current direction)

Y = distance along extension of outfall into water column (i.e., south, across current)

Z = vertical distance above (+) or below (-) outfall centerline.

Four hydrographic conditions were identified: one winter and three summer (Table 3-3).

Attachment 1 presents the results of the CORMIX analysis for the three summer hydrographic conditions. The winter condition was derived using mathematics associated with the turbulent jet theory; whereby, the minimum dilution which occurs on the centerline of the effluent jet is calculated as a function of distance from the nozzle (Attachment 1).

TABLE 3-1
Observed Water Column Structure Near Proposed Liberty Island Site

	Summer Open Water			Winter Ice Covered
	Unstratified Water Column		Stratified Water Column	Unstratified Water Column
	Strong East Wind Years	Weak East Wind Years		
Surface Layer Characteristics				
Ice Thickness	0 m	0 m	0	2 m
Surface Layer Thickness	6 m	6 m	2.5 m	5 m*
Temperature	0.1° to 3.0° C	-0.2° to 2.0° C	1.0° to 5.0° C	-1.5° C
Salinity	15 to 30 ppt**	12 to 30 ppt**	17 to 28 ppt	32.4 ppt
Pycnocline Depth	none	none	3 m	not applicable
Bottom Layer Characteristics				
Temperature	not applicable	not applicable	-1.2 to 0.6	not applicable
Salinity	not applicable	not applicable	30 ppt	not applicable
Typical Duration				
	~ 65 days	~ 40 days	~ 50 days	~ 250 days
<p>* denotes the water column interval under 2 meters (m) of ice ** denotes unstratified waters that increase to marine conditions (30 ppt) throughout the open water season Source: Endicott Monitoring Program USACE 1987-1994</p>				

TABLE 3-2
Observed Current Velocities Near Proposed Liberty Island Site

	Early Open Water Season	Late Open Water Season	Winter Ice Cover Season
Current Speed			
Average Speed	5 cm/s	14 cm/s	1.7 cm/s
Maximum Speed	24 cm/s	68 cm/s	6 cm/s
Current Direction			
Orientation	East/West	East/West	East/West
Source: Endicott Monitoring Program USACE 1987-1994			

TABLE 3-3 Comparison of Liberty Discharges with Ambient Water Quality and Alaska Water Quality Criteria

Outfall	Source	Flow Rate (gpd)		Temp. (°C)	Salinity (ppt)	pH	Pollutants							
		max.	avg.				TSS (mg/l)		BOD (mg/l)		TRC (mg/l)		FC/100 ml	
				max.	max.	max. (average)	max.	avg.	max.	avg.	max.	avg.	max.	avg.
Individual Streams														
001(a)	Continuous Flush	21,600	21,600	amb+0.7	amb	amb±0.1	amb	amb	0	0	≤ 0.002	≤ 0.002	0	0
001(b)	Desalination Potable Water	57,600	40,320	amb+7	2 x amb	amb-0.85 (amb-0.5)	2 x amb	2 x amb	0	0	≤ 0.002	≤ 0.002	0	0
001(c)	Wastewater Sewage Discharge	10,080	9,072	18	0	7.7 (7.15)	34	25	25	15	≤ 0.002	≤ 0.002	200	16
001(d)	Seawater Treatment Plant Backwash - Win	22,118	22,118	amb+1	amb	amb±1	1,600	780	0	0	≤ 0.002	≤ 0.002	0	0
001(d)	Seawater Treatment Plant Backwash - Sum	22,118	22,118	amb+1	amb	amb±1	28,000	4,600	0	0	≤ 0.002	≤ 0.002	0	0
001 Combinations														
001(all)	All flows combined - winter	111,398	93,110	4.2	34.9	amb±0.1	327	193	2	1	≤ 0.002	≤ 0.002	18	2
001(all)	All flows combined - summer	111,398	93,110	7.2	34.9	amb±0.1	5570	1281	2	1	≤ 0.002	≤ 0.002	18	2
Alaska Water Quality Criteria¹				dT<1	dS<4	d(pH)<0.1	n/a	30	n/a	30	0.002	0.002	n/a	14

Ambient Conditions ²	Temperature (°C)				Salinity (ppt)				pH	TSS (mg/l) ³	Current Speed (cm/s) ⁴			Remarks
	Upper		Lower		Upper		Lower				(avg.)	(avg.)	90%-tile	
	min.	max.	min.	max.	min.	max.	min.	max.						
Winter - Ice cover (2 m), unstratified	-1.5	-1.5	n/a	n/a	32.4	32.4	n/a	n/a	8	15	6.0	1.7	0.5	Vertical distance from outfalls to underside of ice = 3 m
Summer - strong east wind, unstratified	0.1	3	n/a	n/a	15	30	n/a	n/a	8	40	22.0	10.0	4	
Summer - weak east wind, unstratified	-0.2	2	n/a	n/a	12	30	n/a	n/a	8	40	25.0	15.0	3.5	
Summer - weak east wind, stratified	1	5	-1.2	0.6	17	25	30	30	8	40	24.0	14.0	3.5	Surface layer = 3 m

Abbreviations:

- amb: ambient
- BOD: biological oxygen demand
- FC/100 ml: fecal chloriform per 100 milliliters
- gpd: gallons per day
- na: not applicable
- none: "none" is inserted in dilution table when effluent meets requirements without further dilution
- ppt: parts per thousand
- TSS: total suspended solids
- TRC: total residual chlorine

¹ Source: Alaska Water Quality Standards For All Marine Water Supply Uses (AWQS) 18 AAC 70.020(a)(2) as amended through March 1, 1998.

² Source: Endicott Monitoring Program USACE 1987-1994

³ Source: Liberty Development Project final NPDES Permit Application

⁴ Average early open water season current was used to represent the worst case or most conservative dilution estimate.

Note: Seawater will be the only effluent discharged from Outfall 002 (fire test water) and therefore, was not modeled.

Outfalls 003, 004 and 005 are upset overflows for deck drainage and will typically not discharge. No modeling was performed for upset deck drainage. See NPDES Permit application for details.

Outfall 006 is temporary construction dewatering and was not modeled.

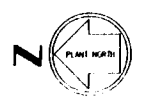
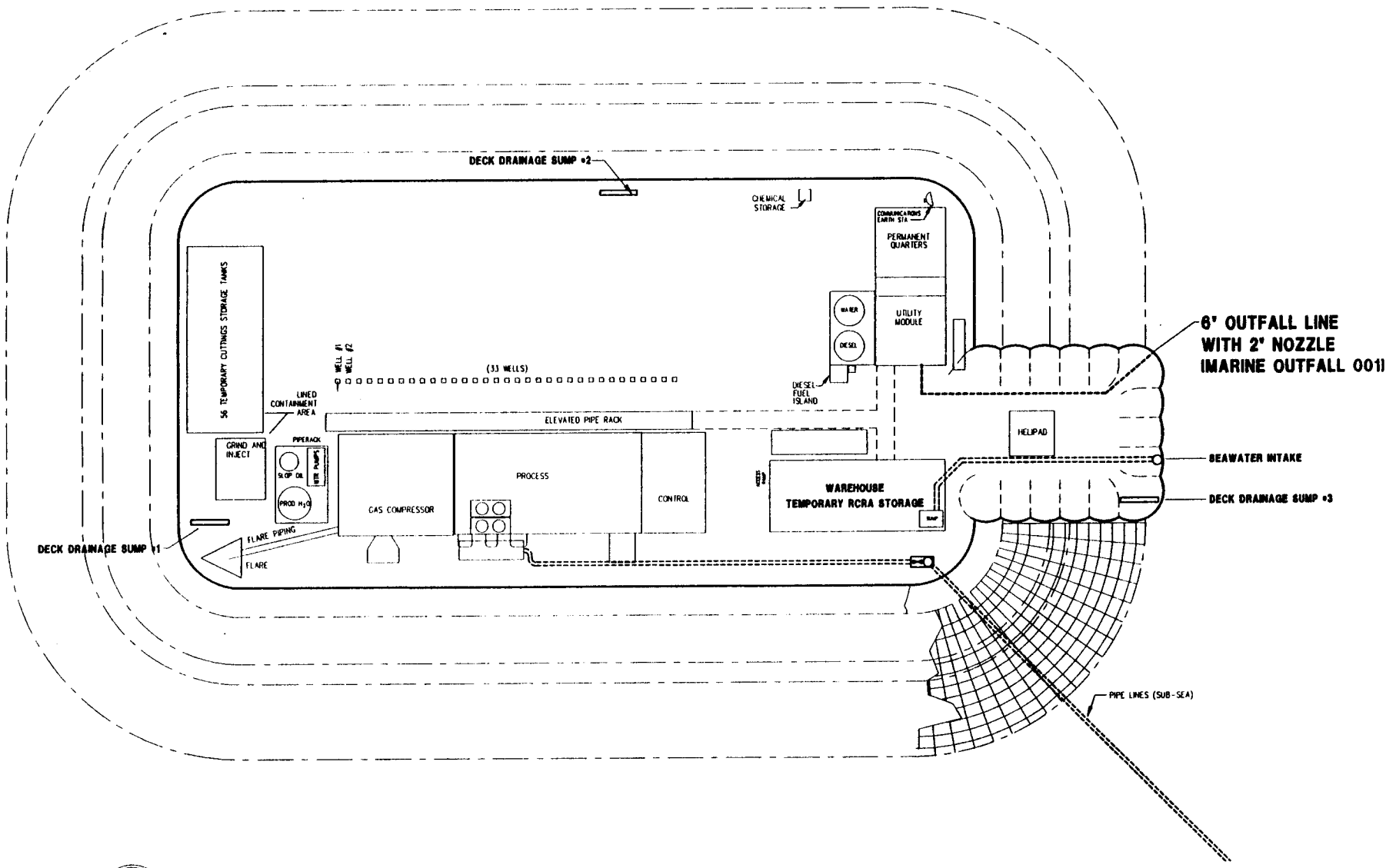

THE ORIENTATION OF THE ISLAND IS RELATIVE TO THE NORTH WELL BE DETERMINED AT A LATER DATE

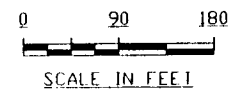

	BP Exploration (Alaska) Inc.
	Liberty Development Project Facility Plan
	Figure 3-1

4.1 INTRODUCTION

Important biological features in the proposed Liberty Development area are discussed in the following sections. Sections 4.6 through 4.11 of the *Liberty Development Environmental Report* (LGL et al. 1998) describe in detail the biological characteristics of the area. This source, along with the *Final Environmental Impact Statement (FEIS) for Lease Sale 144* (MMS 1996), provided the majority of the information summarized below.

4.2 OVERVIEW OF MARINE/ESTUARINE COMMUNITIES AND ECOSYSTEMS

4.2.1 Phytoplankton

Plankton communities in the Alaskan Beaufort Sea are found both within the water column and on the underside of sea ice (Horner et al. 1969, 1979). Ice, turbidity, and spring breakup patterns influence the timing and degree of primary productivity realized from these communities. In the Beaufort Sea, there is no real evidence of a major spring phytoplankton bloom; instead there is a small increase in phytoplankton numbers during and after ice breakup (MMS 1996).

The abundance of phytoplankton appears to be greatest in nearshore waters with decreasing numbers farther offshore. Within Foggy Island Bay, phytoplankton population levels were low from November through March with flagellates dominating the community (Horner and Schrader 1984). By May, diatoms were more numerous and flagellates were still abundant. Productivity was low within the water column, but was higher for neritic forms.

4.2.2 Zooplankton

Due to the low level of primary productivity in the Alaskan Beaufort Sea, the zooplankton communities of this area are also impoverished and are characterized by low diversity, low biomass and slow growth. Marine and estuarine species of zooplankton occur in the nearshore environment during open-water periods. The zooplankton community is composed mainly of copepods and euphausiids, both of which are an important food source for shorebirds, gulls, and terns. Zooplankton are also prey items for epibenthic crustaceans. Zooplankton communities within Foggy Island Bay, are dominated by copepods (Horner and Schrader 1984). Amphipods are also present in the zooplankton community.

4.2.3 Epibenthos

Epibenthos is defined as benthic invertebrates that reside on or near the surface of the substrate. In general, epibenthic species diversity and abundance increase as water depth increases. The proportion of longer-lived sessile or sedentary species also increases as compared to the more motile and opportunistic species found closer to shore in shallower waters. The presence of the shore-fast ice in the nearshore zone (waters <2-m deep) prevents most species from overwintering in this zone. Therefore, the nearshore benthic community is dominated by motile, opportunistic species that can recolonize the area after the ice melts in the spring (Broad 1977, Broad et al 1978, Feder et al. 1976 Grider et al 1977, and 1978, Chin et al. 1979). The most abundant groups in this zone include epibenthic amphipods, mysids, and isopods.

Epibenthic invertebrates were sampled in Foggy Island Bay in 1985 and 1986 as part of the Endicott Monitoring Program (Cannon et al. 1987, Knutzen et al 1990). Average biomass in Foggy Island Bay was comparable to areas to the west such as the Sagavanirktok Delta and Gwydyr Bay. Invertebrate abundance was generally correlated with water temperature and salinity, with higher abundance in areas subject to mixing of fresh and marine waters.

4.2.4 Benthic Infauna

Infaunal organisms live within the substrate and, as a result, often are sedentary. As mentioned above, relatively few species are found in nearshore waters with depths less than 2 m. Any polychaetes and clams found in this zone protect themselves from the harsh and variable substrate conditions by burrowing into the sediment. Other infaunal organisms such as oligochaete worms and clams increase in abundance toward the deeper edge of this zone, reflecting the greater substrate stability found further offshore (LGL et al 1998).

Although shorefast ice can occur in the shallower end of the inshore zone, the diversity and biomass of infauna increase and species composition changes in the inshore environment where water depths range from 2 to 10 m. This zone can support a greater diversity of benthic organisms and up to about 10 times the biomass of the nearshore zone. Polychaetes represent 70 to 80 percent of the total infauna at water depths ranging from 5 to 10 m (Carey 1978).

4.2.5 Boulder Patch Kelp Community

Areas in Stefansson Sound with dense rock cover (more than 25 percent rock cover) are known to contain a rich epilithic flora and fauna, including extensive kelp beds (Reimnitz and Toimil 1976). Isolated patches of marine life also occur in areas where the rocks are more widely scattered (10 to 25 percent rock cover). These areas of Stefansson Sound containing rocky substrate have been charted and are designated as the “Boulder Patch.” Although boulders up to 2-m across and 1-meter high are sometimes encountered, most of the rock cover occurs in the pebble to cobble size range (2 to 256 mm on the Modified Wentworth Scale). Stefansson Sound provides the necessary combination of rocky substrate, depth sufficient to allow a 12- to 14-ft thick layer of free water under the ice during winter, and the presence of offshore shoals and barrier islands that protect the area from extensive gouging and reworking of the bottom by ice (Dunton and Schonberg 1981).

The boulders, and attached dominant kelp species, *Laminaria solidungula*, provide habitat for a large number of invertebrate species. Sponges and cnidarians, including the soft coral *Gersemia rubiformis*, are the most conspicuous invertebrates. Approximately 98 percent of the carbon produced annually in the Boulder Patch is derived from kelp and phytoplankton. *Laminaria* is estimated to contribute 50 to 56 percent of the annual production depending on whether the plants are beneath clear or turbid ice (Dunton 1984). Photosynthesis is limited to a short period during the year when light is available and ice cover has receded. During this time, *Laminaria* stores food reserves until the winter and early spring when nutrients are available to support growth. Thus, blade elongation (growth) is greatest during periods of darkness and turbid ice cover (Dunton and Schell 1986). The only herbivore that consumes kelp in the Boulder Patch is the chiton, *Amicula vestita* (Dunton 1984).

4.2.6 Fish

The nearshore zone serves as a movement corridor for fishes that are intolerant of more marine conditions and as feeding habitat for both anadromous and marine fishes (Craig 1984). Arctic and least cisco, Arctic cod, Dolly Varden and fourhorn sculpin comprise 90 percent of the fish caught in nearshore Beaufort sea areas. In addition to Dolly Varden (age 5 and older), anadromous fishes in the nearshore zone include Arctic cisco (all ages), and adult and subadult least cisco and broad whitefish. The Sagavanirktok River supports a population of broad white fish and occasional pink and chum salmon (LGL et al 1998). The anadromous fish enter the nearshore waters at the start of breakup (early June) to feed during the summer. During open-water periods, anadromous fish are concentrated in the nearshore zone. The fish then return to low salinity water in deep channels of rivers and deltas to overwinter. The Sagavanirktok River Delta provides important fish habitat for overwintering, and in some cases spawning (Fechhelm et al. 1996). Marine species may be found in and adjacent to nearshore waters, including primarily Arctic cod, saffron cod, fourhorn sculpin, Arctic flounder, and rainbow smelt (LGL et al. 1998).

Arctic cod are the most dominant species in the Arctic Ocean and are the most abundant fish collected in the Prudhoe Bay region. Snailfish, another widely distributed taxon in the Beaufort and Chukchi seas, are also taken in moderate numbers in the Prudhoe Bay area and, therefore, also will likely be found in the Liberty Development Project area (LGL et al. 1998).

4.2.7 Marine Mammals

Eight species of marine mammals, including two baleen whales (bowhead and gray whales), one toothed whale (beluga whale), four pinnipeds (ringed seal, bearded seal, spotted seal, and walrus) and the polar bear, inhabit or visit the Alaskan Beaufort Sea regularly. Descriptions of non-endangered marine mammals in the Beaufort Sea have been presented in FEISs for Lease Sales 97, 109, 124, 144, and 170 (MMS 1987a, 1987b, 1990, 1996, 1997, respectively) and are incorporated by reference.

Bowhead and beluga whales migrate through the Alaskan Beaufort Sea. Gray whales, which sometimes summer in Alaskan Beaufort Sea water near Point Barrow, are unlikely to be present in the area of concern. The Liberty Development Project is located inside the barrier islands and south of the usual migration corridor used by bowhead and beluga whales. The bowhead whale is currently listed as an endangered species (see Section 4.3). The Beaufort Sea stock of beluga whales is not in decline or otherwise threatened by present levels of human activities, and therefore, is not classified as a strategic stock (Small and DeMaster 1995). In 1994, the gray whale was removed from the List of Endangered and Threatened Wildlife (Small and DeMaster 1995).

The “ice seals” (ringed, bearded, and spotted seals) are usually observed in open-water areas during summer and early autumn, although spotted seals also haul-out on beaches and offshore islands and bars, and can be found in bays, lagoons, and estuaries. Ringed seals are found in areas of landfast ice during winter, while bearded seals occupy the active ice zone during winter and spring (LGL et al 1998). A few ringed and bearded seals were seen near the project area during the MMS aerial surveys. Spotted seals were not identified during aerial surveys (Frost et al. 1997). Boat-based marine mammal monitoring conducted from July 25 to September 18,

1996 in an area near and to the west of the proposed Liberty Development Project, documented the presence of all three seals, with 92 percent ringed seals, 7 percent bearded seals, and 1 percent spotted seals (Harris et al. 1997). Site-specific BPXA-sponsored aerial surveys for ringed seals were initiated around Liberty in May/June 1997. These surveys, over landfast ice, found ringed seals widely distributed throughout the Liberty area, but no other seal species were encountered (LGL et al. 1998).

Polar bears are normally associated with the pack ice, well offshore of the development area. Denning females, females with cubs, and subadult males may occasionally come ashore; and females with young cubs hunt in fast-ice areas. Most female polar bears den on pack ice, but five den sites on land have been identified within the development area (LGL et al. 1998). Polar bears may also den on barrier islands near the development area. They may be near the Liberty Development Project at any time, although the animals are most likely to occur near the coast in the fall. Polar bears also may be attracted to the development area by whale carcasses disposed of on Cross Island by Native subsistence hunters. In November 1996, at least 28 polar bears were attracted to the island by a whale carcass (LGL et al. 1998).

4.2.8 Birds

An estimated 10 million individual birds representing over 120 species use the Beaufort Sea area from Point Barrow, Alaska to Victoria Island, NWT, Canada (Johnson and Herter 1989). Descriptions of marine and coastal birds in the Alaskan Beaufort Sea area have been presented in the Liberty Development Environmental Report (LGL et al. 1998) and the FEISs for Lease Sales 97, 109, 124 and 144 (MMS 1987a, 1987b, 1990, 1996, respectively, and are incorporated by reference). Nearly all species are migratory, occurring in the Arctic from May through September. The most abundant marine and coastal birds in the Foggy Island Bay and the Liberty Development Project areas include Oldsquaw, Glaucous Gull, Common Eider, Snow Goose, Red Phalaropes, and Red-necked Phalaropes, Semipalmated Sandpiper, Dunlin, and Stilt Sandpiper. The Liberty Development Environmental Report (LGL et al. 1998) lists species likely to occur in the study area.

4.3 THREATENED AND ENDANGERED SPECIES

The Western Arctic (Bering-Chukchi-Beaufort) stock of bowhead whales (*Balaena mysticetus*) is currently listed as endangered under the Endangered Species Act, and thus is classified as a strategic stock by the National Marine Fisheries Service (NMFS) (Small and DeMaster 1995). The population is currently estimated to consist of about 8,000 animals with numbers increasing at a rate of 2.3 percent per year (Small and DeMaster 1995).

Western Arctic bowheads winter in the central and western Bering Sea, summer in the Canadian Beaufort Sea, and migrate around Alaska in spring and autumn (Moore and Reeves 1993). Spring migration through the western Beaufort Sea occurs through offshore ice leads, generally from mid-April to mid-June. The migration corridor is located very far offshore of the Liberty Development area; however, a few bowheads have been observed in lagoon entrances and shoreward of the barrier islands during MMS and LGL surveys (LGL et al. 1998). Autumn migration of bowheads into Alaskan waters occurs primarily during September and October. A few bowheads can be found offshore of the development area in late August during some years,

but the main migration period begins in early to mid-September, with the migration ending by late October. During fall migration, most of the bowheads sighted migrate in water ranging from 65- to 165-ft deep. These migration corridors are all outside of the development area. When passing the development area, most bowheads are in depths > 65 ft, but a few occur closer to shore in some years (LGL et al. 1998).

In addition to the bowhead whale, there are two threatened or endangered bird species which may occur near the Liberty Development Project area, but outside of the effects of the effluent discharge. The Spectacled Eider (*Somateria fischeri*) is the only endangered or threatened bird likely to occur regularly in the study area. The Alaska-breeding population of the Steller's Eider (*Polysticta stelleri*) was listed as threatened on 11 July 1997 by the U.S. Fish and Wildlife Service (62 *Federal Register* 31748). This species may occur in very low numbers in the Prudhoe Bay area and may occur occasionally in the study area. The Arctic Peregrine Falcon (*Falco peregrinus tundrius*) had been listed as threatened, but the U.S. Fish and Wildlife Service removed it from the list on 5 October 1994 (59 *Federal Register* 50796). The Eskimo curlew, although historically present, is now considered to be extirpated from the area.

5.1 INTRODUCTION

As described in Section 2, discharges from the Liberty Development to the waters of Foggy Island Bay include facility effluent (Outfalls 001 and 002) and facility construction dewatering (Outfall 006). Of the facility effluent discharges, only that from Outfall 001 is discussed below. Fire Test Water (Outfall 002) is chemically untreated seawater. Temporary dewatering activities may be required during construction and pipeline installation at Liberty Island (Outfall 006). Discharge from Outfall 006 may contain fines from clean gravel fill used to construct the island. Water column TSS could be altered temporarily in the vicinity of the discharge. These operations will be required over a 2- to 4-week period and will be operated under the Liberty Development NPDES permit limitations and monitoring requirements.

5.2 BIOLOGICAL EFFECTS OF DISCHARGES

Potential biological effects from exposure to the Liberty Island discharges can be characterized by defining effluent characteristics for Outfalls 001, 002, and 006, target receptors, and exposure pathways for the receptors.

As presented in the *Final NPDES Permit Application for the Liberty Development Project* dated 3 April 1998 (Woodward-Clyde), and further described in Section 2 of this ODCE, water column parameters that could be altered by the facility effluent from Liberty Island include:

- Temperature
- Salinity
- pH
- Total Suspended Solids (TSS)
- Dissolved Oxygen (due to changes in Biological Oxygen Demand [BOD])
- Total Residual Chlorine (TRC)
- Fecal Coliform

Collectively these parameters can be termed “stressors.” Stressors are defined by the EPA as “any physical, chemical, or biological entity that can induce an adverse effect” (*Framework for Ecological Risk Assessment, Risk Assessment Forum, EPA, February, 1992*). Adverse ecological effects can encompass a wide range of disturbances ranging from mortality in an individual organism to a loss in ecosystem function. To date, the EPA has not set an acute aquatic life criteria for any of these stressors (*EPA Water Quality Standards Handbook Second Edition, September 1993*).

Target receptors are those organisms that may be exposed to stressors either at the location of release or as a result of advection/dispersion to an offsite area. The marine resources within the Liberty Development, and in particular those organisms that may be found in the vicinity of Liberty Island are described in Section 4 of this ODCE and in detail in the *Liberty Development Environmental Report* (LGL et al. 1998). The potential target receptors include:

- Marine fish

- Anadromous fish
- Shellfish and other benthic organisms
- Marine mammals
- Birds
- Kelp

An exposure pathway is defined as the route by which a stressor is transported to and received by a target receptor. A complete exposure pathway includes:

- Source and mechanism for release of the stressor to the environment
- Transport medium for the stressor
- Point-of-contact on/in the receptor
- Reliable exposure route for the stressor to contact the target receptor.

5.2.1 Outfall 001

The proposed discharge from Outfall 001 provides a source and mechanism for release of the stressors listed above and defined in Section 2. The receiving waters are a transport medium for the stressors to potentially contact the target receptors, and each of the receptors has a point-of-contact for exposure to the stressors introduced into the transport medium. Example points-of-contact include epidermis, gills, and alimentary canals. Determination of a viable and realistic exposure route includes examining expected exposure times (duration) and exposure intensity (concentration of stressors). Therefore, it can be shown that a source and mechanism for exposure, a transport medium for exposure, and a point-of-contact on each target receptor exist; however, in order to have a complete exposure pathway, the exposure route must be viable and realistic. The following paragraphs examine these issues.

Table 5-1, *Water Quality Ranges for Organisms that may be Encountered in the Vicinity of Liberty Island* and Table 5-2, *Dilution of Expected Contaminants in Effluent from Outfall 001* analyze the potential exposure of target receptors to stressors from the discharges.

Using these tables and figures in addition to information presented on Table 3-3, the following sections discuss the potential impact of each stressor on the target receptors. The EPA framework for exposure analysis is provided in *Framework for Ecological Risk Assessment, Risk Assessment Forum, EPA, February, 1992*. Following this framework, each exposure discussion is based on the typical organism tolerances to the stressor (as defined through a search of published literature, as summarized in Table 5-1), the intensity (concentration) of the stressor (both end of pipe and within the immediate vicinity of the outfall, as shown on Table 5-2), and the spatial scale of the stressor prior to dilution to AWQS (as shown on the tables).

5.2.1.1 Temperature

Based on the results of a literature search, a tabulation of typical tolerance ranges for organisms that may be encountered in the vicinity of the discharge is presented (see Table 5-1). This tabulation shows that both marine and anadromous fish exhibit temperature tolerances ranging

from about 0 to 14°C. The marine species that may be in the vicinity of the island during winter are capable of withstanding temperatures to -1.5°C. As shown on Table 5-1, very little information exists concerning the tolerance of planktonic organisms to increases in temperature.

As shown on Table 5-2 temperatures encountered at the end of pipe are within typical tolerance ranges for target receptors expected in the vicinity of the island. The end of pipe temperatures for all flows combined range from 4.2°C in the winter to 7.2°C in the summer (see Table 3-3). These temperatures are as much as 8.7°C greater than ambient conditions. However, as shown in Table 5-1, many if not all of the plankton and fish species expected in the vicinity of the island during summer are tolerant to water temperatures of up to 15 or 16°C, or for the case of Arctic cisco, up to 22°C. Table 5-2 shows that temperatures are cooled to <1°C above ambient within 2 m of the outfall. For the species expected to be encountered in the vicinity of the island during the winter (plankton, cod, sculpins, and snailfish; the duration of exposure to warmer temperatures (spatial scale of 2 m from the outfall) is not expected to be deleterious.

5.2.1.2 Salinity

Table 5-1 shows that target receptors (i.e., anadromous fish such as Dolly Varden, Arctic cisco, and least cisco; and marine fish such as Arctic cod, rainbow smelt, larval capelin, and saffron cod) can tolerate salinities as high as 32‰. The marine species present in winter are likely to be able to tolerate the higher salinities often found under ice. As shown on Table 5-1, very little information exists concerning the tolerance of planktonic organisms to increases in salinity. Table 5-1 shows that chaetognaths can tolerate the marine salinities expected in the vicinity of Liberty Island, while the mysids are not as salinity tolerant.

Based on the literature search and summary of tolerances provided in Table 5-1 and expected dilutions shown in Table 5-2, salinity values that are slightly greater than expected organism tolerances could be encountered in the immediate vicinity of the outfall. For both winter and summer conditions, the salinity of the effluent is expected to be 34.9 ‰. However, dilution effectively reduces the salinity to tolerable levels (18-32‰) within 2.5 m of the pipe. Free swimming fish species and marine mammals could avoid or swim out of the more saline waters immediately adjacent to the discharge pipe.

Planktonic species, which do not have the capability to swim out of unfavorable water conditions may have a slight potential to be adversely impacted by the more saline waters. However due to: 1) the small percentage of planktonic organisms that would be expected to drift into the plume at any given time, 2) the rapid dilution of the effluent, 3) the turbulence of the jet that would flush the organisms from the plume, and 4) the small size of the plume in relationship to the receiving waters, the exposure route for these organisms is expected to be insignificant.

5.2.1.3 pH

The literature search provided no information concerning the tolerance to pH changes of fish, plankton, or other receptor species. In terms of evaluating risk to fish, plankton, benthos and other marine organisms, pH in all flows combined will be within 0.1 pH unit of background (see Table 3-3). Since the typical ambient pH can vary from 7.7 to 8.1, the small changes in pH that

may be encountered in the immediate vicinity of the outfall will pose no risk to the target receptors.

5.2.1.4 Total Suspended Solids (TSS)

The literature search found very few data on the specific effects of increased turbidity or TSS on marine biota. However, as shown on Table 5-1, fish such as Arctic cod, Dolly Varden, Arctic cisco, least cisco, and broad whitefish, humpback whitefish, and rainbow smelt are able to tolerate waters exhibiting high turbidity values (up to 146 NTU, which equates to a visibility of about 5 cm). An empirical relationship between TSS and turbidity has not been established.

It can be seen on Table 5-2, that for winter receiving water conditions, a dilution of 50:1 will be reached at a point 12.5 m from Outfall 001, providing an estimated average TSS concentration of 18.6 mg/L. This assumes a winter average ambient TSS value of 15 mg/L. Under all summer receiving water conditions, a dilution of 50:1 occurs at 6 m or less from Outfall 001. Within this zone, average TSS values could exceed 60 mg/L. However, ambient average TSS during the summer at this location is estimated to be 40 mg/L with maximum ambient TSS values as high as 200 mg/L expected. Based on the tolerance to high turbidity of organisms found in the vicinity of the island, (see Table 5-1) the increased suspended sediments are not expected to be detrimental or lethal to organisms in the immediate vicinity of the outfall.

5.2.1.5 Biological Oxygen Demand (BOD)

As shown on Table 3-3, BOD_{avg} in the combined effluents is very low at the terminus of Outfall 001. As a result the exposure pathway for this potential stressor is not complete, and no adverse effects are expected.

5.2.1.6 Total Residual Chlorine (TRC)

The waste streams will undergo a sophisticated dechlorination process. Therefore, the concentration of TRC in effluent from Outfalls 001 will not exceed 2 parts per billion (ppb). Since engineering controls will be in place to remove chlorine from the effluent, there is no reason to believe chlorine will be discharged through Outfall 001.

5.2.1.7 Fecal Coliform

The sanitary and domestic wastewater system will be a U. S. Coast Guard certified marine sanitation device (MSD) that complies with pollution control standards and regulations under Section 312 of the Clean Water Act. Fecal coliform in effluent from Outfall 001 is expected to be well below AWQS at the end of the pipe. Therefore since water quality standards are met, no adverse effects from this potential stressor are expected.

5.2.1.8 Conclusions

As presented above and summarized on Table 5.3, each of the potential stressors defined in Section 5.2 can be eliminated from a risk standpoint. Under a worst case dilution scenario, effluent concentrations for salinity and temperature reached near ambient conditions within 2.5 m

(8.2 ft) of the outfall. The worst case dilution scenario for TSS concentrations indicated that near ambient conditions were achieved within 6 m (20 ft) of the outfall during summer conditions and 12.5 m (40 ft) of the outfall during winter conditions.

It is anticipated that these stressors will have a negligible impact to organisms since the zone immediately adjacent to the outfall where pollutant concentrations are above ambient is small, and the affected biological community has been shown to be tolerant of the expected pollutant concentrations. Therefore, the discharge of process water effluent through Outfall 001, will not result in unreasonable degradation of the marine environment.

5.2.2 Outfall 002

It is anticipated that only chemically-untreated seawater with ambient water quality properties will be released. All water quality parameters are expected to be similar to ambient water conditions, therefore, parameters such as temperature, pH, TSS are not considered to be stressors in this discharge. Therefore, test discharges from the fire control system will not result in unreasonable degradation of the marine environment.

5.2.3 Outfall 006

There will be no chemical additives in the seawater that will be discharged from these excavations. All water quality parameters, with the exception of TSS, are expected to be similar to ambient receiving water conditions, therefore, parameters such as temperature, salinity, and pH are not considered to be stressors for this discharge.

It is anticipated that TSS concentrations will be above ambient receiving water conditions in the excavations. Receiving waters adjacent to the gravel island are expected to exhibit elevated TSS concentrations as a result of pipeline trench excavation, and winnowing of the fine-grained fraction from the slope of the gravel island.

5.3 PHYSICAL EFFECTS OF DISCHARGES

Turbidity of the receiving waters will be temporarily increased in the immediate vicinity of Outfall 001 during construction dewatering activities (Outfall 006). However, as discussed in Section 5.2.3, the input of suspended matter into the water column due to discharges from Outfall 006 is likely to be surpassed by the increased turbidity due to placement of fill for island construction.

Increased turbidity can cause abrasion or clogging of gills and feeding structures in larvae, benthos, and fish in the immediate vicinity of the discharge. Motile organisms may be able to avoid the plume.

Increased turbidity may also cause adverse impacts to kelp by decreasing the light available for photosynthesis. Toimil and Dunton (1984) found a reduction in linear growth of *Laminaria solidungula* at three sites near eroding artificial gravel islands. The growth reduction was attributed to increased turbidity downstream of the eroding island. However, as shown in Section 5.2., nearly ambient conditions are reached at 6 m downstream of Outfall 001 in summer and 12.5 m downstream in winter.

5.4 EFFECTS ON THREATENED AND ENDANGERED SPECIES

As discussed in Section 4, three threatened or endangered species may occur in the Liberty Development area. The Spectacled Eider and the Steller's Eider are unlikely to be affected since these birds are not expected to forage directly in the discharge area. Therefore, no direct effects of the discharge will occur. The endangered bowhead whale is also an unlikely visitor to the area inside of the barrier islands, and these mammals do not feed in the shallow waters surrounding Liberty Island. They would not be likely to encounter the discharge.

TABLE 5-1 Water Quality tolerance Ranges for Organisms that May be Encountered in the Vicinity of Liberty Island

Organism	Salinity (o/oo)	Temp. (°C)	pH	Turbidity (NTU)	TSS (mg/l)	Comments	Reference
Plankton							
chaetognaths (<i>Parasagitta elegans</i>)	30-32	-1 - 0	-	-	-	environmental conditions	Welch, Siferd, and Bruecker 1996
Mysids (<i>Mysis litoralis</i>)	>28	<4	-	-	-		Cannon, Knutzen, and Glass. 1991
Mysids (<i>M. femorata</i>)	0.1 - 20	up to 16	-	-	-	water conditions during sampling	J.W. Wacasey 1975
Mysids (<i>M. relicta</i>)	0.1 - 20	up to 16	-	-	-	water conditions during sampling	J.W. Wacasey 1975
Benthos							
Soft shell clam (<i>Mya arenaria</i>)	-	-	-	-	<100		Grant and Thorpe 1991
clam (<i>Macoma calcarea</i>)	30 - 33	-0.1 to -1.6	-	-	-	water conditions during sampling	J.W. Wacasey 1975
Blue mussel (<i>Mytilus edulis</i>)	-	-	-	-	100-200	reduced respiration in exposed mussels	Widdows, Fieth and Worral 1979
Fish							
Juvenile Arctic cod (<i>Boreogadus saida</i>)	0-32	4 - 10	-	-	-		Cannon, Glass and Prewitt. 1991
Arctic cod (<i>B. saida</i>)	3 - 28	0 - 13.5	-	1 - 146	-	no info exists on pH	AK Habitat Management Guide 1986
Arctic cod (<i>B. saida</i>)	15-25	2 - 6	-	-	-		Robertson 1991
Arctic cod (<i>B. saida</i>) (summer)	3 - 28	0 - 13.5	-	1 - 146	-	observed conditions where fishes were caught	Craig 1984
Arctic cod (<i>B. saida</i>) (winter)	23 - 31	-2	-	-	-	observed conditions where fishes were caught	Craig 1984
Arctic anadromous fish	28	12	-	-	-		English 1991
Dolly Varden (<i>Salvelinus malma</i>) (summer)	2 - 32	0.5 - 14	-	1 - 146	-	observed conditions where fishes were caught	Craig 1984
Dolly Varden (<i>S. malma</i>) (winter)	0	0 - 2	-	-	-	observed conditions where fishes were caught	Craig 1984
Dolly Varden (<i>S. malma</i>)	2 - 32	0.5 - 13	-	-	-		AK Habitat Management Guide 1986

NTU - Nephelometric Turbidity Units

TSS - Total Suspended Solids

Note: a "dash" indicates no data

TABLE 5-1 Water Quality tolerance Ranges for Organisms that May be Encountered in the Vicinity of Liberty Island

Organism	Salinity (o/oo)	Temp. (°C)	pH	Turbidity (NTU)	TSS (mg/l)	Comments	Reference
1yo Arctic cisco (<i>Coregonus autumnalis</i>)	6 - 30	>5	-	-	-	with salinity acclimation and high food ration	Fechhlem et al 1993
1yo Arctic cisco (<i>C. autumnalis</i>)	-	11.5 - 15.4	-	-	-	preferred temp. of satiated fish	Fechhlem et al 1993
2-4yo Arctic cisco (<i>C. autumnalis</i>)	<26	3 - 12	-	-	-		Fechhelm et al 1991
Arctic cisco (<i>C. autumnalis</i>) (summer)	2 - 32	0-13.5	-	1 - 146	-	observed conditions where fishes were caught	Craig 1984
Arctic cisco (<i>C. autumnalis</i>) (winter)	2 - 32	-1.7	-	-	-	observed conditions where fishes were caught	Craig 1984
Arctic cisco (<i>C. autumnalis</i>)	<16	4 - 10	-	-	-		Robertson 1991
Arctic cisco (<i>C. autumnalis</i>)	28 - 30	3	-	-	-	LD50	Bryan and Fechhelm 1996
Arctic cisco (<i>C. autumnalis</i>)	8 - 12	5 - 22	-	-	-	highest growth rate occurs	Bryan and Fechhelm 1996
Arctic cisco (<i>C. autumnalis</i>)	5	11.5	-	-	-	when acclimated at 5°C/5ppt	Fechhelm et al 1983
Arctic cisco (<i>C. autumnalis</i>)	15	15.4	-	-	-	when acclimated at 15°C/15ppt	Fechhelm et al 1983
Least cisco (<i>C. sardinella</i>) (summer)	2 - 32	1 - 14	-	1 - 146	-	observed conditions where fishes were caught	Craig 1984
Least cisco (<i>C. sardinella</i>) (winter)	0 - 32	-1.7 - 0	-	-	-	observed conditions where fishes were caught	Craig 1984
Least cisco (<i>C. sardinella</i>)	0 - 24	-	-	-	-		Robertson 1991
Least cisco (<i>C. sardinella</i>)	1 - 25	0 - 13	-	1 - 146	-	No info exists on pH	
Lake Whitefish (<i>C. clupeaformis</i>)	-	5 - 12	-	-	-	maximal activity at 12°C	Bernatchez and Dodson 1985
Broad whitefish (<i>C. nasus</i>) (summer)	2 - 30	1 - 14	-	2 - 146	-	observed conditions where fishes were caught	Craig 1984
Broad whitefish (<i>C. nasus</i>) (winter)	0	0	-	-	-	observed conditions where fishes were caught	Craig 1984
Broad whitefish (<i>C. nasus</i>) (12-19 mm size)	15	15	-	-	-		de March 1988
Broad whitefish (<i>C. nasus</i>) (>27 mm size)	20 - 27	5 - 15	-	-	-	moribund fish recovered after 5 days exposure	de March 1988
Broad whitefish (<i>C. nasus</i>)	2.5 - 20	0 - 16	5.5-9.0	1 - 146	20		AK Habitat Management Guide 1986

NTU - Nephelometric Turbidity Units

TSS - Total Suspended Solids

Note: a "dash" indicates no data

TABLE 5-1 Water Quality tolerance Ranges for Organisms that May be Encountered in the Vicinity of Liberty Island

Organism	Salinity (o/oo)	Temp. (°C)	pH	Turbidity (NTU)	TSS (mg/l)	Comments	Reference
Yearling broad whitefish (<i>C. nasus</i>)	1 - 8	8.6 - 12.2	-	-	-	absence of growth below 2.6°C	Fechhelm et al 1992
Humpback whitefish (<i>C. pidschian</i>) (summer)	2 - 28	1 - 12	-	4 - 146	-	observed conditions where fishes were caught	Craig 1984
Humpback whitefish (<i>C. pidschian</i>) (winter)	0 - 28	0	-	-	-	observed conditions where fishes were caught	Craig 1984
Fourhorn sculpin (<i>Myoxocephalus quadricornis</i>) (summer)	2 - 31	0 - 13.5	-	1 - 146	-	observed conditions where fishes were caught	Craig 1984
Fourhorn sculpin (<i>M. quadricornis</i>) (winter)	5 - 22	-1.7	-	-	-	observed conditions where fishes were caught	Craig 1984
Arctic flounder (<i>Liopsetta glacialis</i>) (summer)	2 - 31	0 - 13.5	-	1 - 82	-	observed conditions where fishes were caught	Craig 1984
Arctic flounder (<i>L. glacialis</i>) (winter)	5 - 30	-	-	-	-	observed conditions where fishes were caught	Craig 1984
Rainbow smelt (<i>Osmerus mordax</i>) (summer)	1 - 29	1 - 13.5	-	2 - 140	-	observed conditions where fishes were caught	Craig 1984
Rainbow smelt (<i>O. mordax</i>) (winter)	1 - 32	-2 to -1	-	-	-	observed conditions where fishes were caught	Craig 1984
Larval capelin (<i>Mallotus villosus</i>)	4.8 - 32.6	0.2 - 14.4	-	-	-	no info exists on pH	AK Habitat Management Guide 1986
Adult capelin (<i>M. villosus</i>)	-	-1 to 1.3	-	-	-	no info exists on pH	AK Habitat Management Guide 1986
Pacific herring (<i>Clupea pallasii</i>)	25	2 - 14	-	-	-		AK Habitat Management Guide 1986
Saffron cod (<i>Eleginus navaga</i>)	18 - 32	-1.8 to 13	-	-	-		AK Habitat Management Guide 1986

NTU - Nephelometric Turbidity Units

TSS - Total Suspended Solids

Note: a "dash" indicates no data

TABLE 5-2 DILUTION OF EXPECTED CONTAMINANTS IN EFFLUENT FROM OUTFALL 001								
	S	Salinity		Temp.		FC/100	BOD	TSS
	(dilution)	‰		(°C)		ml Avg.	(mg/l)* Max.	(mg/l)* Avg.
Receiving water - winter		32.4		-1.5		0	0	15
Effluent-all flows at end of pipe	-	34.5		4.2		2	1	193
Effluent-all flows at 1.3 m	5	32.8		-0.4		0.4	0.2	50.6
Effluent-all flows at 2.5 m	10	32.6		-0.9		0.2	0.1	32.8
Effluent-all flows at 12.5 m	50	n/a		n/a		n/a	n/a	18.6
		Min.	Max.	Min.	Max.			
Receiving water - summer (strong east wind)		15	30	0.1	3	0	0	40
Effluent-all flows at end of pipe	-	34.9	34.9	7.2	7.2	3	5	1281
Effluent-all flows at 0.5 m	3	21.6	31.6	2.5	4.4	1.0	1.7	453.7
Effluent-all flows at 1.0 m	5	19.0	31.0	1.5	3.8	0.6	1.0	288.2
Effluent-all flows at 1.8 m	10	17.0	30.5	0.8	3.4	0.3	0.5	164.1
Effluent-all flows at 5.7 m	50	n/a	n/a	n/a	n/a	n/a	n/a	64.8
Receiving water - summer (weak east wind)		12	30	-0.2	2	0	0	40
Effluent-all flows at end of pipe	-	34.9	34.9	7.2	7.2	2	2	1281
Effluent-all flows at 0.5 m	3	19.6	31.6	2.3	3.7	0.7	0.7	453.7
Effluent-all flows at 1.0 m	5	16.6	31.0	1.3	3.0	0.4	0.4	288.2
Effluent-all flows at 1.7 m	10	14.3	30.5	0.5	2.5	0.2	0.2	164.1
Effluent-all flows at 5.3 m	50	n/a	n/a	n/a	n/a	n/a	n/a	64.8
Receiving water - summer (weak east wind)*		17	30	-1.2	5	0	0	40
Effluent-all flows at end of pipe	-	34.9	34.9	7.2	7.2	2	2	1281
Effluent-all flows at 0.5 m	3	23.0	31.6	1.6	5.7	0.7	0.7	453.7
Effluent-all flows at 1.0 m	5	20.6	31.0	0.5	6.9	0.4	0.4	288.2
Effluent-all flows at 2 m	10	18.8	30.5	-0.4	5.9	0.2	0.2	164.1
Effluent-all flows at 6 m	50	n/a	n/a	n/a	n/a	n/a	n/a	64.8
*stratified								

Table 5-3 SUMMARY OF POTENTIAL STRESSOR EFFECTS

Receptors	STRESSORS						
	<i>Temperature</i>	<i>Salinity</i>	<i>pH</i>	<i>TSS</i>	<i>BOD¹</i>	<i>TRC¹</i>	<i>Fecal Choliform¹</i>
Marine Fish	Tolerant of the expected exposure ²	Tolerant of the expected exposure ²	Duration and spatial scale of exposure is inadequate to produce deleterious effects	Tolerant of the expected exposure ²	Incomplete pathway; no deleterious exposure expected	Engineering controls for removal; no deleterious exposure expected	Incomplete pathway; no deleterious exposure expected
Anadromous Fish	Tolerant of the expected exposure ²	Tolerant of the expected exposure ²	Duration and spatial scale of expected exposure inadequate to produce deleterious effects	Tolerant of the expected exposure ²	Incomplete pathway; no deleterious exposure expected	Engineering controls for removal; no deleterious exposure expected	Incomplete pathway; no deleterious exposure expected
Shellfish and Benthics	Duration and spatial scale of expected exposure inadequate to produce deleterious effects	Duration and spatial scale of expected exposure inadequate to produce deleterious effects	Duration and spatial scale of expected exposure inadequate to produce deleterious effects	Tolerant of the expected exposure ²	Incomplete pathway; no deleterious exposure expected	Engineering controls for removal; no deleterious exposure expected	Incomplete pathway; no deleterious exposure expected
Birds	Minimal exposure expected; receptors not likely to feed or remain in immediate vicinity of outfall	Minimal exposure expected; receptors not likely to feed or remain in immediate vicinity of outfall	Duration and spatial scale of expected exposure inadequate to produce deleterious effects	Duration and spatial scale of expected exposure inadequate to produce deleterious effects	Incomplete pathway; no deleterious exposure expected	Engineering controls for removal; no deleterious exposure expected	Incomplete pathway; no deleterious exposure expected
Kelp	Duration and spatial scale of expected exposure inadequate to produce deleterious effects	Duration and spatial scale of expected exposure inadequate to produce deleterious effects	Duration and spatial scale of expected exposure inadequate to produce deleterious effects	Duration and spatial scale of expected exposure inadequate to produce deleterious effects	Incomplete pathway; no deleterious exposure expected	Engineering controls for removal; no deleterious exposure expected	Incomplete pathway; no deleterious exposure expected

Table 5-3 SUMMARY OF POTENTIAL STRESSOR EFFECTS

Receptors	STRESSORS						
	<i>Temperature</i>	<i>Salinity</i>	<i>pH</i>	<i>TSS</i>	<i>BOD</i> ¹	<i>TRC</i> ¹	<i>Fecal Choliform</i> ¹
Marine Mammals	Duration and spatial scale of expected exposure inadequate to produce deleterious effects	Duration and spatial scale of expected exposure inadequate to produce deleterious effects	Duration and spatial scale of expected exposure inadequate to produce deleterious effects	Duration and spatial scale of expected exposure inadequate to produce deleterious effects	Incomplete pathway; no deleterious exposure expected	Engineering controls for removal; no deleterious exposure expected	Incomplete pathway; no deleterious exposure expected
Threatened and Endangered Species	Minimal exposure expected; receptors not likely to feed or remain in immediate vicinity of outfall	Minimal exposure expected; receptors not likely to feed or remain in immediate vicinity of outfall	Minimal exposure expected; receptors not likely to feed or remain in immediate vicinity of outfall	Duration and spatial scale of expected exposure inadequate to produce deleterious effects	Incomplete pathway; no deleterious exposure expected	Engineering controls for removal; no deleterious exposure expected	Incomplete pathway; no deleterious exposure expected

¹End-of-pipe concentrations meet water quality standards

²See Table 5.1

6.1 INTRODUCTION

Sections 4 and 5 of the *Liberty Development Environmental Report* (LGL et. al. 1998) describe in detail commercial, recreational, and subsistence uses of this area. This source, along with the *Final Environmental Impact Statement (FEIS) for Lease Sale 144* (MMS 1996) provides references for the information presented herein.

6.2 COMMERCIAL HARVESTS

There is only one continuous commercial fishing operation on the Alaskan North Slope, operated from the Colville River delta primarily for Arctic cisco. Broad and humpback whitefish and least cisco are also harvested and sold.

6.3 SUBSISTENCE HARVESTS

Much of the resident population within the NSB is dependent on subsistence hunting and fishing. Subsistence has been the traditional land use within the study area and is at least a component of all cultural resources. The Liberty Development Project is located inshore of the broad area described by Nuiqsut whalers as most important to them. This area also has been used on occasion as a sealing area, and the onshore area is also used on occasion as a hunting/trapping area for furbearers. Most documented seal harvest by Nuiqsut hunters takes place closer to the community (with a primary use area centered on Thetis Island in Harrison Bay, extending from Fish Creek on the west to Pingok Island on the east). The project area has been reported by villagers as important for taking seals while whaling and as a place to look for seals in the summer.

6.4 RECREATIONAL FISHERY

Limited sport fishing is found near villages. Arctic char is the main sport fish caught.

6.5 EFFECTS OF WASTE DISCHARGES

6.5.1 Commercial Harvest Effects

The Liberty Development will have negligible effects on the Colville River commercial fishing operation.

6.5.2 Subsistence Harvests Effects

Offshore Island Construction

Direct effects upon marine mammals (ringed seals) will be minimal, and winter use of this area by subsistence hunters is little or none. Thus, offshore island construction will be expected to have minimal or no effect upon subsistence activities. It is assumed that gravel placement will occur during the winter, and the only open-water construction will be for island slope protection (concrete block, gravel bags) and foundation construction. The open-water period is the main

season for sealing, and displacement effects will be localized enough so as to be minimal. Whales will not be present in the proposed project area during island construction, so whales and whaling will not be affected.

Potential biological effects on fish are judged to be minimal, and subsistence use of the area is infrequent and limited to summer. Similarly, effects upon terrestrial subsistence resources and their use will be minimal. The effects of gravel extraction for construction purposes is assumed to be minimal because the mine site is not in an area of biological significance and subsistence use.

Oil Production Operations

The most significant potential subsistence effects occur in this phase of the project. Noise effects are shared to some extent with prior developmental phases, although the source of the noise differs.

Noise will arise primarily from drilling and support traffic (boat, air, ice-road vehicle). Production equipment also will be a source of noise, not be as loud but at more regular intervals. The main direct effect will be localized displacement of seals—both from the area of the gravel island (drilling noise and traffic) and from the proximity of vessels and aircraft in transit. Whales are not expected to be directly affected by noise, as their normal migration route (seaward of the barrier islands) is beyond the transmission range of the noise expected to be generated. Vessel and aircraft traffic, if close to the animals, can cause a significant displacement of whales.

Seals may be directly affected by spill incidents. Whales are less likely to be affected by oil spills because of their more seasonal use of the area and their greater distance from the production area and pipeline. Such effects are nonetheless possible. Potential effects upon subsistence uses for seals will still be relatively low, as the area most likely to be affected is not one of high use for subsistence sealing. The potential effects upon subsistence whaling, however, are quite large and could extend to Nuiqsut's principal whaling area. This effect could be limited to the displacement of Nuiqsut whaling to alternate areas, or could eliminate an entire whaling season if a spill incident occurred during the relatively short, fall whaling season. Drilling will be continuous for a 2-year period, and probably carries the greatest risk for a relatively large scale spill. Pipeline spills are possible for the total production period of the project. Either type of spill could occur at any time of the year.

As mentioned previously, fish resources in this area were historically used in the past, but currently are not used due to the area's distance from Nuiqsut. Therefore, overall subsistence effects of oil production operations will be non-existent.

Direct effects of an oil spill upon terrestrial subsistence resources and their use will be minimal. Use of the area by subsistence hunters is very low due to the distance from present communities and other already existing developments.

Oil-spill cleanup activities could increase disturbance effects on subsistence resources from vessel and aircraft traffic, causing temporary disruption and possible displacement effects (MMS 1996). In the event of a large spill contacting and extensively oiling coastal habitats, a large number of humans, boats, and aircraft involved in the cleanup could potentially displace seals, polar bears, and other marine mammals, and increase stress and reduce pup survival of ringed seals if operations occurred in the spring. Such effects could persist for 1 or more years within

1 mile of the cleanup. Birds within about 1 mile could be affected for one or two seasons. Caribou could be displaced and could experience seasonal stress for one or two seasons in areas near cleanup activities. Oil spill and cleanup activities in river delta areas during fish migrations will have adverse effects on these fish, and will displace nesting, molting, and feeding birds and contribute to their reduced reproductive success. Oil-spill cleanup activity will exacerbate and increase disturbance effects to subsistence species, increase the displacement of subsistence species, and alter or reduce access to subsistence species.

6.5.3 Recreational Fishery Effects

Under normal operations, the Liberty Development Project, and all of its ancillary activities (e.g., subsea pipeline, boat traffic, discharges), will have no significant effect on anadromous or marine fishes in the region. Wastewater from island processes will either be injected or will meet NPDES permit requirements. Although salinity, temperature and other parameters could be increased over ambient levels in the immediate vicinity of the outfall, deleterious effects to fish populations are not expected. The development represents an extremely localized disturbance offshore of summer fish habitat. The mobile nature of fishes in the area will allow them to easily circumvent point disruptions. Adult anadromous fishes can range hundreds of kilometers along the coast each summer, and navigate across coastal topographic irregularities far more extensive than the Liberty Development Project.

The Coastal Zone Management Act requires that states make consistency determinations for any federally licensed or permitted activity affecting the coastal zone of a state with an approved Coastal Zone Management Plan (16 USC Sec. 1456 [c] [A] Subpart D). The Liberty Development Project will include the construction of a subsea pipeline from shore, into state waters, beyond the 3-mile limit, and into federal waters. With submittal of the *Liberty Development and Production Plan* in February 1998, BPXA certified the project was consistent with the Alaska Coastal Management Program (ACMP). In support of the certification, BPXA submitted an analysis of compliance with relevant coastal management policies.

SECTION EIGHT Marine Water Quality Criteria and Water Quality Standards

8.1 FEDERAL STANDARDS

8.1.1 New Source Performance Standards

All discharges will be in accordance with the New Source Performance Standards (NSPS) for Oil and Gas Extraction Point Sources as specified in 40 CFR Part 435. The effluent limitations are summarized below.

New Source Performance Standards

Waste Source	Pollutant Parameter	NSPS
Produced water	oil and grease	The maximum for any one day shall not exceed 42 mg/l; the average of daily values for 30 consecutive days shall not exceed 29 mg/l.
Drilling fluids and drill cuttings: (A) For facilities located within 3 miles from shore		No discharge. ¹
(B) For facilities located more than 3 miles from shore	Toxicity	Minimum 96-hr LC50 of the suspended particulate phase shall be 3 percent by volume ²
	Free oil	No discharge. ³
	Diesel oil	No discharge
	Mercury	1 mg/kg dry weight maximum in the stock barite
	Cadmium	3 mg/kg dry weight maximum in the stock barite
Well treatment, completion, and workover fluids.	Oil and grease	The maximum for any one day shall not exceed 42 mg/l; the average of daily values for 30 consecutive days shall not exceed 29 mg/l
Deck drainage	Free oil ⁴	No discharge
Produced sand		No discharge
Sanitary M10 ⁵	Residual chlorine	Minimum of 1 mg/l and maintained as close to this as possible
Sanitary M9IM ⁶	Floating solids	No discharge
Domestic Waste	Floating solids	No discharge
	Foam	No discharge
	All other domestic wastes	See 33 CFR Part 151

¹All Alaskan facilities are subject to the drilling fluids and drill cuttings discharge standards for facilities located more than three miles offshore.

²As determined by the toxicity test (40 CFR Part 435 Appendix 2).

³As determined by the static sheen test (40 CFR Part 435 Appendix 1).

⁴As determined by the presence of a film or sheen upon or a discoloration of the surface of the receiving water (visual sheen).

⁵M10: Offshore facilities continuously manned by ten or more persons

⁶M9IM Offshore facilities continuously manned by nine or fewer persons or only intermittently manned by any number of persons.

SECTION EIGHT Marine Water Quality Criteria and Water Quality Standards

EPA Marine Water Quality Criteria

Marine water quality criteria (45 FR 79318, as amended in 50 FR 30784) are stated as acute (or maximum at any time) and 24-hour average values. Acute criteria values are based on acute toxicity data for animals and are applicable to instantaneous releases or short-term discharges of pollutants. The 24-hour average values are applicable to longer-term discharges of pollutants and are designed to protect aquatic life and its uses from chronic toxicity and bioconcentration. Each 24-hour average criterion is the lowest of three values used to protect for chronic toxicity to animals, toxicity to plants, and bioconcentration. Both sets of criteria are applicable to discharges from the Liberty project.

As detailed in the NPDES Permit application, the pollutants of concern which will be discharged from the Liberty facility are:

- Temperature
- pH
- Salinity
- Biological Oxygen Demand (BOD)
- Fecal Coliform
- Total Residual Chlorine
- Total Suspended Solids (TSS)

Because the Liberty facility will be constructed in federal waters, EPA marine water quality criteria will be applicable. All discharges will be in accordance with the EPA marine water quality criteria. Table 8-1 presents a comparison of EPA and State of Alaska marine water quality criteria for the contaminants of concern.

8.2 STATE STANDARDS

It is possible that TSS in the immediate vicinity of either alternative pipeline trench will be increased as much as 50 mg/L above ambient during construction. This value is based on data obtained in the Northstar Development area during an under-ice trenching study (Montgomery Watson 1996). This study found increases of 20 to 30 mg/L TSS within 46 m (150 ft) of the trench. Sediments in the Northstar Development are expected to be of similar grain size to those at the Liberty Development.

8.3 EFFECTS OF DISCHARGES

The NPDES-permitted effluent discharges associated with the Liberty Project are expected to have no significant effect on the receiving waters.

TABLE 8-1
Comparison of U.S. EPA and State of Alaska
Marine Water Criteria for Contaminants of Concern

Pollutants Which Will be Discharged Under the NPDES Permit	U.S. EPA Marine Water Quality Criteria ¹		Alaska Water Quality Standards ²
	Acute Criteria	Chronic Criteria	Marine
Biological Oxygen Demand (BOD)	None	None	None
Total Residual Chlorine	13 ug/L	7.5 ug/L	0.002 ug/L
Fecal Coliform	None	None	14 FC/100
pH	None	6.5 - 8.5	d(pH)<0.1
Salinity	None	None	dS<4
Temperature	See narrative ³	See narrative ³	dT<1
Turbidity	See narrative ⁴	See narrative ⁴	25 NTU

"None" is used where no standards exist for this parameter.

¹Source: U.S. EPA Quality Criteria for Water 1986, EPA 440/5-86-001 (45 FR 79318, as amended in 50 FR 30784).

²Source: Alaska water quality standards (AWQS) for all marine water supply uses 18 AAC 70.020(a)(2) as amended through March 1, 1998.

³In order to assure protection of the characteristic indigenous marine community of a water body segment from adverse thermal effects: a) the maximum acceptable increase in the weekly average resulting from artificial sources is 1° C (1.8° F) during all seasons of the year, providing the summer maximum are not exceeded; and
b) daily temperature cycles characteristic of the water body segment should not be altered in either amplitude or frequency.

⁴Settleable and suspended solids should not reduce the depth of the compensation point for photosynthetic activity by more than 10 percent from the seasonally established norm for aquatic life

9.1 INTRODUCTION

After addressing the ten factors listed in the Ocean Discharge Criteria guidelines, EPA must determine whether a discharge will result in unreasonable degradation of the marine environment (see Section 1). These factors have been addressed in Sections 2 through 8. Based on this analysis, EPA has concluded that the discharges will not cause unreasonable degradation of the marine environment, assuming that all relevant permit conditions and effluent limitations are in place.

9.2 DETERMINATION

EPA has evaluated the potential environmental impacts from the proposed discharges and various approaches to setting effluent limitations. Effluent limitations should be designed to limit the toxicity of the discharges.

9.3 MONITORING REQUIREMENTS

The proposed monitoring program for the NPDES permit is discussed in the draft permit and fact sheet.

9.4 CONCLUSIONS

EPA's tentative determinations with respect to the Ocean Discharge Criteria are presented above and in the fact sheet and draft permit. These determinations will be reviewed at the close of the public comment period and a final determination will be reached with respect to permit conditions.

- Arctic Environmental Information and Data Center (AEIDC). 1974. Alaska Regional Profiles. Vol. II. Arctic Region. University of Alaska, Anchorage, AK.
- BPXA. 1998A. Final NPDES Permit Application, Liberty Development Project.
- BPXA. 1998B. Liberty Development Project Development and Production Plan. February 1998.
- Britch, R.P., R.C. Miller, J.P. Downing, T. Petrillo, and M. Vert. 1983. Volume II physical processes. *In*: B.J. Gallaway and R.P. Britch (eds.). Environmental Summer Studies (1982) for the Endicott Development. LGL Alaska Research Associates, Inc. and Harding Technical Services. Report for SOHIO Alaska Petroleum Company, Anchorage, Alaska. 219 pp.
- Broad, A.C. 1977. Environmental assessment of selected habitats in the Beaufort and Chukchi Sea littoral system. *In*: Environmental Assessment Alaskan Continental Shelf. Quarterly report. BLM/NOAA, OCSEAP. Boulder, CO.
- Broad, A.C., H. Koch, D.T. Mason, G.M. Petrie, D.E. Schneider, and R.J. Taylor. 1978. Environmental assessment of selected habitats in the Beaufort Sea littoral system. *In*: Environmental Assessment of the Alaskan Continental Shelf. Annual report. NOAA. Boulder, CO.
- Bureau of Land Management. 1979. Beaufort Sea proposed federal/state oil and gas lease sale. Final Environmental Impact Statement. Alaska Outer Continental Shelf Region, BLM, U.S. Dept. Of Interior. Anchorage, AK. 3 Vols.
- Cannon, T.C., B.A. Adams, D. Glass and T. Nelson. 1987. Fish distribution and abundance. pp. 29. *In*: Endicott environmental monitoring program, final reports, 1985. Vol. 6. Report by Envirosphere Co. for Alaska District, U.S. Army Corps of Engineers, Anchorage, AK.
- Carey, A.G., Jr. (ed.). 1978. Marine biota (plankton, benthos, fish). pp. 174-237. *In*: Environmental Assessment of the Alaskan Continental Shelf, Interim Synthesis: Beaufort/Chukchi. Outer Continental Shelf Environmental Assessment Program, Boulder, CO.
- Chin, H., M. Busdosh, G.A. Robilliard and R.W. Firth, Jr. 1979. Environmental Studies Associated with the Prudhoe Bay Dock - Physical Oceanography and Benthic Ecology. The 1978 studies. Prepared for ARCO Oil and Gas Company by Woodward-Clyde Consultants, Anchorage, AK.
- Colonell, J.M. and A.W. Niedoroda. 1990. Appendix B. Coastal oceanography of the Alaska Beaufort Sea. Pp. B-1-B-74 *In*: Colonell, J.M. and B.J. Gallaway (eds.). An Assessment of Marine Environmental Impacts of West Dock Causeway. Report for the Prudhoe Bay Unit Owners represented by ARCO Alaska, Inc. prepared by LGL Alaska Research Associates, Inc. and Environmental Science and Engineering, Inc. Anchorage, Alaska. 132 pp. + appendices.
- Craig, P.C. 1984. Fish use of coastal waters of the Beaufort Sea: A review. Transactions of the American Fisheries Society 113:265-282.

- Doneken, R.L. and G.M. Jirka. 1990. Expert systems for hydrocarbon dynamic mixing zone analysis of conventional and toxic submerged single port discharges (CORMIX1). Environmental Research Laboratory. Office of Research and Development. U. S. Environmental Protection Agency, Athens, GA. EPA/600/3-90/012.
- Dunton, K.H. 1984. An annual carbon budget for an arctic kelp community. pp. 311-326. *In*: P. Barnes, D. Schell and E. Reimnitz (eds.). The Alaska Beaufort Sea ecosystem and environment. Academic Press, Orlando.
- Dunton, K.H. and S.V. Schonberg. 1981. Ecology of the Stefansson Sound kelp community: II. Results of *in situ* and benthic studies. *In*: A.C. Broad et al., Environmental assessment of selected habitats in the Beaufort and Chukchi littoral system. Annual Report, April 1981, in Environmental Assessment of the Alaskan Continental Shelf. NOAA Environmental Research Labs., Boulder, CO. 65 pp.
- Dunton, K.H. and D.M. Schell. 1986. A seasonal carbon budget for the kelp *Laminaria solidungula* in the Alaskan High Arctic. *Mar. Ecol. Prog. Ser.* 31:57-66.
- Fechhelm, R.G., W.B. Griffiths, W.J. Wilson, B.A. Trimm and J.M. Colonell. 1996. The 1995 Fish and Oceanography Study, Mikkelsen Bay, Alaska. Northern Alaska Research Studies. Prepared by LGL Research Associates Inc. and Woodward-Clyde Consultants for BP Exploration (Alaska) Inc., Anchorage, Alaska.
- Feder, H.M., D.G. Shaw and A.S. Naidu. 1976. The arctic coastal environment in Alaska. Institute of Marine Science Reports R-76-7. Vol. 1-3. University of Alaska.
- Frost, K.J., L.F. Lowry, S. Hills, G. Pendleton and D. DeMaster. 1997. Monitoring distribution and abundance of ringed seals in northern Alaska. Rep. From Alaska Dept. of Fish and Game, Juneau, AK, to Minerals Management Service, Anchorage, AK. Final Interim Report, May 1996-March 1997. 42 pp.
- Grider, G.W., G.A. Robilliard and R.W. Firth. 1977. Environmental studies associated with the Prudhoe Bay dock: coastal processes and marine benthos. Final Report. Prepared for Atlantic Richfield Corp. Prepared by Woodward-Clyde Consultants, Anchorage, AK.
- Grider, G.W., G.A. Robilliard and R.W. Firth. 1978. Environmental studies associated with the Prudhoe Bay dock: coastal processes and marine benthos. Final Report. Prepared for Atlantic Richfield Corp. Prepared by Woodward-Clyde Consultants, Anchorage, AK.
- Harris, R.E., G.W. Miller, R.E. Elliott and W.J. Richardson. 1997. Seals (Chapter 4, p. 42) *In*: W.J. Richardson (ed.), Northstar marine mammal monitoring program, 1996: marine mammal and acoustical monitoring of a seismic program in the Alaskan Beaufort Sea. LGL Rep. 2121-2. Rep. from LGL Ltd., King City, Ont. and Greeneridge Sciences Inc., Santa Barbara, CA, for BP Explor. (Alaska) Inc., Anchorage, AK and Nat. Mar. Fish. Serv., Anchorage, AK and Silver Spring, MD. 245 pp.
- Horner, R.A. 1969. Phytoplankton in coastal waters near Barrow, Alaska. Ph.D. Thesis. Univ. Wash., Seattle. 261 pp.

- Horner, R.A. 1979. Beaufort Sea plankton studies. RU 359. Environmental Assessment of the Alaskan Continental Shelf. Annual Reports of Principal Investigators for the Year Ending March 1979. Vol. III: Receptors - Fish, Littoral, Benthos (Oct. 1979). Boulder, CO: USDOC, NOAA, and USDO, BLM, pp. 543-639.
- Horner, R.A. and C.G. Schrader. 1984. Beaufort Sea plankton studies: winter-spring studies in Stefansson Sound and off Narwhal Island November 1978-June 1980. U.S. Dept. Commer., NOAA, OCSEAP Final Rep. 25:193-325.
- Johnson, S.R. and D.R. Herter. 1989. The birds of the Beaufort Sea. BP Exploration (Alaska) Inc., Anchorage, AK. 372 pp.
- Knutzen, J.A., M.S. Brancato and S.C. Jewett. 1990. Fish prey surveys (drop nets). Vol. 7, Chap. 3 in 1986 Endicott Environmental Monitoring Program. Report by EnviroSphere Company to U.S. Army Corps of Engineers, Alaska District, Anchorage, AK 86 pp
- LGL Alaska Research Associates, Inc. Applied Sociocultural Research; and Woodward-Clyde Consultants. 1998. Final Environmental Report, Liberty Development Project. Prepared for BP Exploration (Alaska), Inc.
- Minerals Management Service. 1987a. Beaufort Sea sale 97 final environmental impact statement. MMS OCS EIS/EA 87-0069. U.S. Dept. of Interior, MMS, Alaska Outer Continental Shelf Region, Anchorage, AK.
- Minerals Management Service. 1987b. Chukchi Sea sale 109 final environmental impact statement. MMS OCS EIS/EA 87-0110. U.S. Dept. of Interior, MMS, Alaska Outer Continental Shelf Region, Anchorage, AK.
- Minerals Management Service. 1990. Beaufort Sea planning area oil and gas lease sale 124. Final Environmental Impact Statement. MMS OCS EIS/EA MMS 90-0063. U.S. Dept. of Interior, MMS, Alaska Outer Continental Shelf Region, Anchorage, AK.
- Minerals Management Service. 1996. Beaufort Sea planning area oil and gas lease sale 144. Final Environmental Impact Statement. MMS OCS EIS/EA MMS 96-0012. U.S. Dept. of Interior, MMS, Alaska Outer Continental Shelf Region, Anchorage, AK.
- Minerals Management Service. 1997. Beaufort Sea planning area oil and gas lease sale 170. Draft Environmental Impact Statement. MMS OCS EIS/EA MMS 97-0011. U.S. Dept. of Interior, MMS, Alaska Outer Continental Shelf Region, Anchorage, AK.
- Montgomery Watson. 1997. Liberty Island Route Water/Sediment Sampling. Prepared for BP Exploration (Alaska). April 1997.
- Montgomery Watson. 1998. Liberty Island Route Water/Sediment Sampling Revised and Corrected Final Data Report. Prepared for BP Exploration (Alaska). August 1998.
- Moore, S.E. and R.R. Reeves. 1993. Distribution and movement. pp. 313-386 *In*: J.J. Burns, J.J. Montague and C.J. Cowles (eds.). The bowhead whale. Spec. Publ. 2. Soc. Mar. Mamm., Lawrence, KS. 787 pp.
- Reimnitz, E. and L. Toimil. 1976. Diving notes from three Beaufort Sea sites. *In*: P. Barnes and E. Reimnitz. Geologic Processes and Hazards of the Beaufort Sea Shelf and Coastal

- Regions. Quarterly Report, December 1976. Nat. Oceanic Atmos. Admin., Boulder, CO. Attachment J. 7 pp.
- Schell, D.M. 1982. Primary production and nutrient dynamics in Simpson Lagoon and adjacent waters. Final Report, OCSEAP, Research Unit 467.
- Small, R.J. and D.P. DeMaster. 1995. Alaska marine mammal stock assessments 1995. U.S. Dept. Commerce, NOAA Tech. Memo. NMFS-AFSC-57. 93 pp.
- Toimil, L.J. and K.H. Dunton. 1984. Summer 1983 supplemental study environmental effect of gravel island construction OCS-Y0191 (BF-37) Beechy Point, Block 480 Stefansson Sound, Alaska. Report prepared for Exxon Co., Houston, TX, by Harding Lawson Associates (HLA Job No. 9612,045.09).
- U.S. Army Corps of Engineers. 1987. 1985 Final Report for the Endicott Monitoring Program, Volume 3, Oceanographic Monitoring. Prepared by Envirosphere Company, Anchorage, AK, for the U.S. Army Corps of Engineers, Alaska District.
- U.S. Army Corps of Engineers. 1990. 1986 Final Report for the Endicott Monitoring Program, Volume 2, Oceanography. Prepared by Envirosphere Company, Anchorage, AK, for the U.S. Army Corps of Engineers, Alaska District.
- U.S. Army Corps of Engineers. 1991. 1987 Final Report for the Endicott Monitoring Program, Volume 2, Oceanography. Prepared by Science Applications International Corporation, Anchorage, AK, for the U.S. Army Corps of Engineers, Alaska District.
- U.S. Army Corps of Engineers. 1992. 1988 Final Report for the Endicott Monitoring Program, Volume 2, Oceanography. Prepared by Science Applications International Corporation, Anchorage, AK, for the U.S. Army Corps of Engineers, Alaska District.
- U.S. Army Corps of Engineers. 1993. 1989 Final Report for the Endicott Monitoring Program, Volume 2, Oceanography. Prepared by Science Applications International Corporation, Anchorage, AK, for the U.S. Army Corps of Engineers, Alaska District.
- U.S. Army Corps of Engineers. 1994. 1990 Final Report for the Endicott Monitoring Program, Volume 2, Oceanography. Prepared by Science Applications International Corporation, Anchorage, AK, for the U.S. Army Corps of Engineers, Alaska District.
- U.S. Minerals Management Service, Alaska, OCS Region. 1998. Liberty Development Project, Development and Production Plan. Prepared by BP Exploration (Alaska) Inc., Anchorage, AK.
- EPA Region 10, 1986. Final Ocean Discharge Criteria Evaluation for the Endicott Development Project.
- Woodward-Clyde Consultants. 1981. Environmental Report for Exploration in the Beaufort Sea Federal/State Outer Continental Shelf Lease Sale. Tern Prospect. Prepared for Shell Oil Company. September 24, 1981.
- Woodward-Clyde Consultants. 1996. The 1995 Northstar Unit sampling program. Benthic sampling. Final report prepared for BP Exploration (Alaska) Inc., Anchorage, AK. 35 pp.

Woodward-Clyde. 1998a. Liberty Development Pipeline Right-of-Way Sediment Analysis. Letter Report to BP Exploration (Alaska) Inc. June 16, 1998.

Woodward-Clyde. 1998b. Liberty Development Water Quality Study. Draft report in preparation for BP Exploration (Alaska) Inc. November, 1998.

ATTACHMENT 1

Winter Hydrographic Condition Dilution Computation

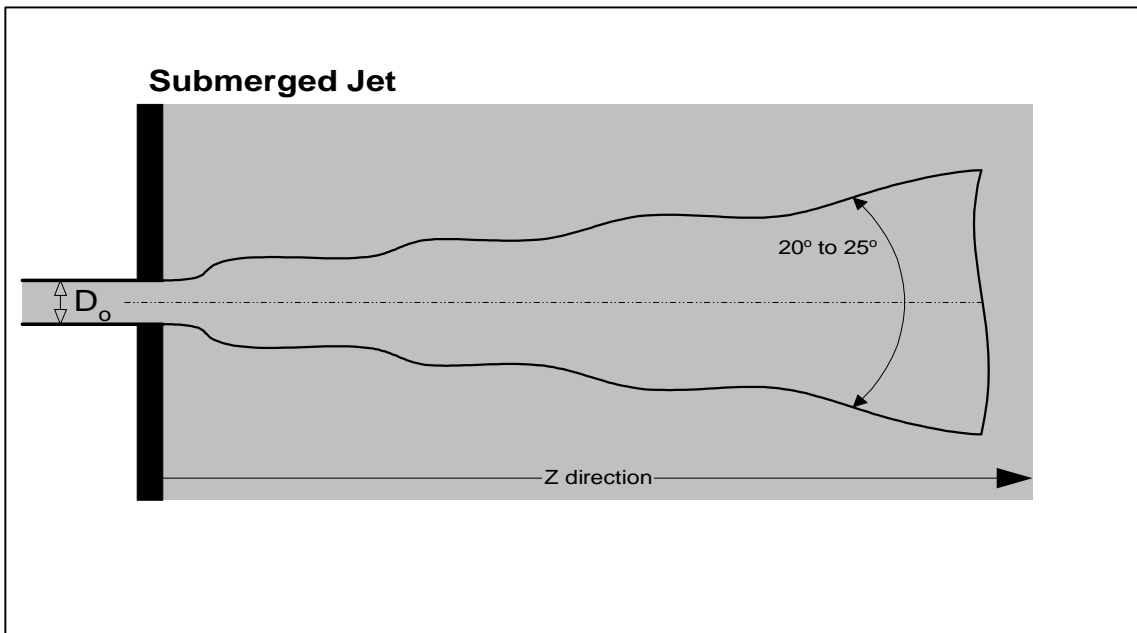

Minimum dilution **S** in jet as function of distance **z**
given by:

$$\mathbf{S} \approx 0.18 \left(\frac{z}{l_Q} \right) \quad \text{where } 10 < \left(\frac{z}{l_Q} \right) < 100$$

Reference: Fischer et al. 1979

$l_Q = \text{length scale for circular jet} = 0.9D_o$

$$\mathbf{Z} = (\mathbf{S}/0.18) 0.9D_o \quad \mathbf{Z} = 5 \mathbf{S} D_o \quad \mathbf{D}_o = 0.05 \text{ m}$$

$$\mathbf{Z} = (5) (5) (0.05 \text{ m}) \quad \text{Dilution of 5:1}$$

$$\mathbf{Z} = 1.25 \text{ m}$$

$$\mathbf{Z} = (5) (10) (0.05 \text{ m}) \quad \text{Dilution of 10:1}$$

$$\mathbf{Z} = 2.5 \text{ m}$$

$$\mathbf{Z} = (5) (50) (0.05 \text{ m}) \quad \text{Dilution of 50:1}$$

$$\mathbf{Z} = 12.5 \text{ m}$$

XX

CORNELL MIXING ZONE EXPERT SYSTEM

_ORMIX1: Submerged Single Port Discharges EPA Version 1.40 (February 1992)

Start of session: 5- 8-1998 16:39:24

_SITE/CASE DESCRIPTION SUMMARY:

Site name	=	summer
Effluent discharger	=	BP
Pollutant	=	TSS
DESIGN CASE	=	summer-wea-east-wind-unstratified
FILE NAME	=	case2

SUMMARY OF AMBIENT CONDITIONS:

The ambient water body is unbounded.

Average water depth	HA	=	7 m
Depth at discharge	HD	=	7 m
Ambient velocity	UA	=	.14 m/s
Manning's n	N	=	.02

The ambient is unstratified.

Ambient density	RHOA	=	1009.8 kg/m^3
-----------------	------	---	---------------

SUMMARY OF DISCHARGE CONDITIONS:

Distance to nearest bank	DISTB	=	7000 m
Nearest bank/shore		=	left
Port height	H0	=	2 m
Vertical angle	THETA	=	0 deg
Horizontal angle	SIGMA	=	90 deg
Port diameter	D0	=	.05 m
Port area	A0	=	0.001963 m^2
Discharge flowrate	Q0	=	.00409 m^3/s
Discharge velocity	U0	=	2.083545 m/s
Discharge density	RHO0	=	1028 kg/m^3
Effluent concentration	C0	=	1281
Concentration units		=	mg-per-l

SUMMARY OF MIXING ZONE PARAMETERS:

The effluent is not toxic as defined by USEPA standards.
An ambient water quality standard applies for this conventional
(non-toxic) pollutant.
CSTD = 30 mg-per-l
No Regulatory Mixing Zone (RMZ) has been specified.
Region Of Interest (ROI) is specified by downstream distance.
XINT = 7000 m from discharge point
Number of intervals for prediction display = 20

Program Element PARAM: Design Case: summer-wea-east-wind-unstrat

Relative density differences between discharge and ambient:
The effluent density (1028 kg/m³) is greater than the surrounding
ambient water density at the discharge level (1009.8 kg/m³).
Therefore, the effluent is negatively buoyant and will tend to sink towards
the bottom.

Flow bulk parameters:
Discharge volume flux Q0 = .00409 m³/s
Discharge momentum flux M0 = 0.008522 m⁴/s².
Discharge buoyancy flux J0 = -0.000723 m⁴/s³.

Flow length scales:
Discharge length scale LQ = 0.044306 m
Jet crossflow length scale Lm = 0.659379 m
Plume to crossflow length scale Lb = 0.263449 m
Jet to plume transition length scale LM = 1.043173 m

Non-dimensional parameters:
Nonsimetric Froude number FRO = 22.163553
Jet/Crossflow Velocity Ratio R = 14.882464

Program Element CLASS: Design Case: summer-wea-east-wind-unstrat

The near field flow configuration will have the following features:

The discharge near-field behavior is dominated by either the negative
buoyancy of the discharge or the downward vertical orientation of the
discharge port leading to bottom interaction.

The following conclusion on the flow configuration applies to a layer
corresponding to the full water depth at the discharge site:

+-----+
Flow class NH1
Applicable layer depth HS = 7 m
+-----+

BEGIN MOD101: DISCHARGE MODULE

PROFILE DEFINITIONS:

B = Gaussian 1/e (37%) half-width, normal to trajectory
C = centerline concentration
S = corresponding centerline dilution

PREDICTION

X	Y	Z	S	C	B
0.00	0.00	2.00	1.0	0.128E+04	0.03

END OF MOD101: DISCHARGE MODULE

BEGIN MOD111: WEAKLY DEFLECTED JET IN CROSSFLOW

CROSSFLOWING DISCHARGE

PROFILE DEFINITIONS:

B = Gaussian 1/e (37%) half-width, normal to trajectory
C = centerline concentration
S = corresponding centerline dilution

PREDICTION

X	Y	Z	S	C	B
0.00	0.00	2.00	1.0	0.128E+04	0.03
0.01	0.08	2.00	1.3	0.970E+03	0.04
0.03	0.16	2.00	1.6	0.780E+03	0.04
0.05	0.24	2.00	2.0	0.653E+03	0.05
0.07	0.32	2.00	2.3	0.561E+03	0.06
0.10	0.39	1.99	2.6	0.492E+03	0.07
0.13	0.47	1.99	2.9	0.438E+03	0.08
0.17	0.55	1.99	3.2	0.395E+03	0.09
0.20	0.63	1.98	3.6	0.359E+03	0.10
0.25	0.71	1.98	3.9	0.330E+03	0.11
0.29	0.79	1.97	4.2	0.304E+03	0.11
0.34	0.87	1.96	4.5	0.283E+03	0.12
0.39	0.95	1.95	4.8	0.264E+03	0.13
0.45	1.03	1.94	5.2	0.248E+03	0.14
0.51	1.11	1.93	5.5	0.233E+03	0.15
0.57	1.18	1.92	5.8	0.220E+03	0.16
0.64	1.26	1.91	6.1	0.209E+03	0.17
0.71	1.34	1.89	6.5	0.198E+03	0.17
0.78	1.42	1.87	6.8	0.189E+03	0.18
0.86	1.50	1.85	7.1	0.181E+03	0.19
0.94	1.58	1.83	7.4	0.173E+03	0.20

END OF MOD111: WEAKLY DEFLECTED JET IN CROSSFLOW

BEGIN MOD122: STRONGLY DEFLECTED PLUME IN CROSSFLOW

NOTE: THE WIDTH PREDICTION B IN THE FIRST ENTRY BELOW MAY EXHIBIT SOME MISMATCH (UP TO A FACTOR OF 1.5) RELATIVE TO THE LAST ENTRY OF THE PREVIOUS MODULE. THIS IS UNAVOIDABLE DUE TO DIFFERENCES IN THE WIDTH DEFINITIONS. THE ACTUAL PHYSICAL TRANSITION WILL BE

SMOOTHED OUT.

PROFILE DEFINITIONS:

B = Gaussian 1/e (37%) half-width, normal to trajectory
C = centerline concentration
S = corresponding centerline dilution

PREDICTION

X	Y	Z	S	C	B
0.94	1.58	1.83	7.4	0.173E+03	0.24
1.19	1.66	1.74	9.3	0.137E+03	0.26
1.45	1.73	1.65	11.3	0.113E+03	0.29
1.70	1.79	1.56	13.4	0.954E+02	0.32
1.95	1.85	1.48	15.6	0.821E+02	0.34
2.21	1.91	1.40	17.9	0.717E+02	0.37
2.46	1.96	1.32	20.2	0.634E+02	0.39
2.72	2.01	1.25	22.6	0.566E+02	0.41
2.97	2.06	1.17	25.1	0.510E+02	0.43
3.23	2.10	1.10	27.6	0.464E+02	0.46
3.48	2.14	1.03	30.2	0.424E+02	0.48
3.73	2.19	0.96	32.9	0.390E+02	0.50
3.99	2.22	0.90	35.6	0.360E+02	0.52
4.24	2.26	0.83	38.4	0.334E+02	0.54
4.50	2.30	0.77	41.2	0.311E+02	0.56

** WATER QUALITY STANDARD OR CCC HAS BEEN FOUND **
THE POLLUTANT CONCENTRATION IN THE PLUME FALLS BELOW THE WATER QUALITY STANDARD
OR CCC VALUE OF 0.30E+02 IN THE CURRENT PREDICTION INTERVAL.
THIS IS THE SPATIAL EXTENT OF CONCENTRATIONS EXCEEDING THE WATER QUALITY
STANDARD OR CCC VALUE.

4.75	2.33	0.70	44.0	0.291E+02	0.58
5.00	2.37	0.64	46.9	0.273E+02	0.59
5.26	2.40	0.58	49.9	0.257E+02	0.61
5.51	2.43	0.52	52.9	0.242E+02	0.63
5.77	2.46	0.46	55.9	0.229E+02	0.65
6.02	2.49	0.40	59.0	0.217E+02	0.67

END OF MOD122: STRONGLY DEFLECTED PLUME IN CROSSFLOW

BEGIN MOD131: LAYER BOUNDARY/TERMINAL LAYER APPROACH

CONTROL VOLUME

PROFILE DEFINITIONS:

BV = top-hat thickness, measured vertically
BH = top-hat half-width, measured horizontally in Y-direction
C = average (bulk) concentration
S = corresponding average (bulk) dilution
ZU = upper plume boundary (Z-coordinate)
ZL = lower plume boundary (Z-coordinate)

PREDICTION

X	Y	Z	S	C	B	BH	ZU	ZL
CONTROL VOLUME INFLOW								
6.02	2.49	0.40	59.0	0.217E+02	0.67			
CONTROL VOLUME OUTFLOW								
7.35	2.49	0.00	100.3	0.128E+02	1.21	1.21	1.21	0.00

END OF MOD131: LAYER BOUNDARY/TERMINAL LAYER APPROACH

END OF HYDRODYNAMIC MIXING ZONE (HMZ) ***

BEGIN MOD141: BUOYANT AMBIENT SPREADING

PROFILE DEFINITIONS:

BV = top-hat thickness, measured vertically
BH = top-hat half-width, measured horizontally in Y-direction
C = average (bulk) concentration
S = corresponding average (bulk) dilution
ZU = upper plume boundary (Z-coordinate)
ZL = lower plume boundary (Z-coordinate)

PREDICTION: STAGE 1: NOT BANK ATTACHED

X	Y	Z	S	C	BV	BH	ZU	ZL
7.35	2.49	0.00	100.3	0.128E+02	1.21	1.21	1.21	0.00
73.99	2.49	0.00	165.7	0.773E+01	0.27	9.00	0.27	0.00
140.62	2.49	0.00	185.2	0.692E+01	0.19	14.05	0.19	0.00
207.26	2.49	0.00	197.8	0.648E+01	0.16	18.30	0.16	0.00
273.90	2.49	0.00	207.4	0.618E+01	0.14	22.11	0.14	0.00
340.53	2.49	0.00	215.2	0.595E+01	0.12	25.61	0.12	0.00
407.17	2.49	0.00	221.7	0.578E+01	0.11	28.89	0.11	0.00
473.80	2.49	0.00	227.5	0.563E+01	0.10	31.99	0.10	0.00
540.44	2.49	0.00	232.5	0.551E+01	0.10	34.94	0.10	0.00
607.07	2.49	0.00	237.1	0.540E+01	0.09	37.78	0.09	0.00
673.71	2.49	0.00	241.3	0.531E+01	0.09	40.51	0.09	0.00
740.35	2.49	0.00	245.2	0.523E+01	0.08	43.16	0.08	0.00
806.98	2.49	0.00	248.7	0.515E+01	0.08	45.72	0.08	0.00
873.62	2.49	0.00	252.0	0.508E+01	0.08	48.22	0.08	0.00
940.25	2.49	0.00	255.2	0.502E+01	0.07	50.65	0.07	0.00
1006.89	2.49	0.00	258.1	0.496E+01	0.07	53.03	0.07	0.00
1073.53	2.49	0.00	260.9	0.491E+01	0.07	55.35	0.07	0.00
1140.16	2.49	0.00	263.5	0.486E+01	0.07	57.62	0.07	0.00
1206.80	2.49	0.00	266.0	0.481E+01	0.06	59.86	0.06	0.00
1273.43	2.49	0.00	268.4	0.477E+01	0.06	62.05	0.06	0.00
1340.07	2.49	0.00	270.7	0.473E+01	0.06	64.20	0.06	0.00

END OF MOD141: BUOYANT AMBIENT SPREADING

BEGIN MOD161: PASSIVE AMBIENT MIXING IN UNIFORM AMBIENT

VERTICAL DIFFUSIVITY OF AMBIENT FLOW: EDIFFV = 0.008878 m**2/s
HORIZONTAL DIFFUSIVITY OF AMBIENT FLOW: EDIFFH = 0.385589 m**2/s

SIMULATION LIMIT BASED ON MAXIMUM SPECIFIED DISTANCE = 7000.00m.
THIS IS THE REGION OF INTEREST LIMITATION.

PROFILE DEFINITIONS:

BV = Gaussian s.d. (46%) thickness, measured vertically
= or equal to layer depth, if fully mixed
BH = Gaussian s.d. (46%) half-width, measured horizontally in Y-direction
C = centerline concentration
S = corresponding centerline dilution
ZU = upper plume boundary (Z-coordinate)
ZL = lower plume boundary (Z-coordinate)

XX

CORNELL MIXING ZONE EXPERT SYSTEM

_ORMIX1: Submerged Single Port Discharges EPA Version 1.40 (February 1992)

Start of session: 5- 8-1998 16:26:30

ITE/CASE DESCRIPTION SUMMARY:

Site name = strong-east-wind
 Effluent discharger = BP
 Pollutant = TSS
 DESIGN CASE = case3
 FILE NAME = case3

SUMMARY OF AMBIENT CONDITIONS:

The ambient water body is unbounded.

Average water depth HA = 7 m
 Depth at discharge HD = 7 m
 Ambient velocity UA = 0.14 m/s
 Manning's n N = .02

The ambient is unstratified.

Ambient density RHOA = 1012 kg/m³

SUMMARY OF DISCHARGE CONDITIONS:

Distance to nearest bank DISTB = 7000 m
 Nearest bank/shore = left
 Port height H0 = 2 m
 Vertical angle THETA = 0 deg
 Horizontal angle SIGMA = 90 deg
 Port diameter D0 = .05 m
 Port area A0 = 0.001963 m²
 Discharge flowrate Q0 = .00409 m³/s
 Discharge velocity U0 = 2.083545 m/s
 Discharge density RHO0 = 1028 kg/m³
 Effluent concentration C0 = 1281
 Concentration units = mg-per-l

SUMMARY OF MIXING ZONE PARAMETERS:

The effluent is not toxic as defined by USEPA standards.
An ambient water quality standard applies for this conventional
(non-toxic) pollutant.
CSTD = 30 mg-per-l
No Regulatory Mixing Zone (RMZ) has been specified.
Region Of Interest (ROI) is specified by downstream distance.
XINT = 7000 m from discharge point
Number of intervals for prediction display = 20

Program Element PARAM: Design Case: case3

Relative density differences between discharge and ambient:
The effluent density (1028 kg/m³) is greater than the surrounding
ambient water density at the discharge level (1012 kg/m³).
Therefore, the effluent is negatively buoyant and will tend to sink towards
the bottom.

Flow bulk parameters:
Discharge volume flux Q0 = .00409 m³/s
Discharge momentum flux M0 = 0.008522 m⁴/s².
Discharge buoyancy flux J0 = -0.000634 m⁴/s³.

Flow length scales:
Discharge length scale LQ = 0.044306 m
Jet crossflow length scale Lm = 0.659379 m
Plume to crossflow length scale Lb = 0.231100 m
Jet to plume transition length scale LM = 1.113793 m

Non-dimensional parameters:
Nonsymmetric Froude number FR0 = 23.663969
Jet/Crossflow Velocity Ratio R = 14.882464

Program Element CLASS: Design Case: case3

The near field flow configuration will have the following features:

The discharge near-field behavior is dominated by either the negative
buoyancy of the discharge or the downward vertical orientation of the
discharge port leading to bottom interaction.

The following conclusion on the flow configuration applies to a layer
corresponding to the full water depth at the discharge site:

+-----+
Flow class NH1
Applicable layer depth HS = 7 m
+-----+

BEGIN MOD101: DISCHARGE MODULE

PROFILE DEFINITIONS:

B = Gaussian 1/e (37%) half-width, normal to trajectory

C = centerline concentration

S = corresponding centerline dilution

PREDICTION

X	Y	Z	S	C	B
0.00	0.00	2.00	1.0	0.128E+04	0.03

END OF MOD101: DISCHARGE MODULE

BEGIN MOD111: WEAKLY DEFLECTED JET IN CROSSFLOW

CROSSFLOWING DISCHARGE

PROFILE DEFINITIONS:

B = Gaussian 1/e (37%) half-width, normal to trajectory

C = centerline concentration

S = corresponding centerline dilution

PREDICTION

X	Y	Z	S	C	B
0.00	0.00	2.00	1.0	0.128E+04	0.03
0.01	0.09	2.00	1.3	0.952E+03	0.04
0.03	0.17	2.00	1.7	0.757E+03	0.05
0.05	0.26	2.00	2.0	0.629E+03	0.06
0.08	0.34	2.00	2.4	0.537E+03	0.06
0.11	0.43	1.99	2.7	0.469E+03	0.07
0.15	0.51	1.99	3.1	0.417E+03	0.08
0.19	0.60	1.99	3.4	0.374E+03	0.09
0.23	0.68	1.98	3.8	0.340E+03	0.10
0.28	0.77	1.98	4.1	0.311E+03	0.11
0.33	0.85	1.97	4.5	0.287E+03	0.12
0.38	0.94	1.96	4.8	0.267E+03	0.13
0.44	1.02	1.95	5.2	0.249E+03	0.14
0.51	1.11	1.94	5.5	0.233E+03	0.15
0.58	1.19	1.93	5.8	0.219E+03	0.16
0.65	1.28	1.91	6.2	0.207E+03	0.17
0.72	1.36	1.90	6.5	0.196E+03	0.18
0.81	1.45	1.88	6.9	0.186E+03	0.19
0.89	1.53	1.86	7.2	0.177E+03	0.20
0.98	1.62	1.84	7.6	0.169E+03	0.21
1.07	1.70	1.82	7.9	0.162E+03	0.21

END OF MOD111: WEAKLY DEFLECTED JET IN CROSSFLOW

BEGIN MOD122: STRONGLY DEFLECTED PLUME IN CROSSFLOW

NOTE: THE WIDTH PREDICTION B IN THE FIRST ENTRY BELOW MAY EXHIBIT SOME MISMATCH (UP TO A FACTOR OF 1.5) RELATIVE TO THE LAST ENTRY OF THE PREVIOUS MODULE. THIS IS UNAVOIDABLE DUE TO DIFFERENCES IN THE WIDTH DEFINITIONS. THE ACTUAL PHYSICAL TRANSITION WILL BE

SMOOTHED OUT.

PROFILE DEFINITIONS:

B = Gaussian 1/e (37%) half-width, normal to trajectory
C = centerline concentration
S = corresponding centerline dilution

PREDICTION

X	Y	Z	S	C	B
1.07	1.70	1.82	7.9	0.162E+03	0.24
1.34	1.78	1.73	9.8	0.130E+03	0.27
1.61	1.85	1.64	11.9	0.108E+03	0.30
1.89	1.92	1.55	14.0	0.915E+02	0.32
2.16	1.98	1.47	16.2	0.790E+02	0.35
2.43	2.03	1.39	18.5	0.693E+02	0.37
2.70	2.08	1.32	20.8	0.615E+02	0.40
2.97	2.13	1.24	23.3	0.551E+02	0.42
3.24	2.18	1.17	25.8	0.497E+02	0.44
3.51	2.23	1.10	28.3	0.453E+02	0.46
3.78	2.27	1.03	30.9	0.414E+02	0.48
4.05	2.31	0.96	33.6	0.381E+02	0.50
4.32	2.35	0.89	36.3	0.353E+02	0.52
4.60	2.39	0.83	39.1	0.328E+02	0.54
4.87	2.42	0.76	41.9	0.306E+02	0.56

** WATER QUALITY STANDARD OR CCC HAS BEEN FOUND **

THE POLLUTANT CONCENTRATION IN THE PLUME FALLS BELOW THE WATER QUALITY STANDARD OR CCC VALUE OF 0.30E+02 IN THE CURRENT PREDICTION INTERVAL.

THIS IS THE SPATIAL EXTENT OF CONCENTRATIONS EXCEEDING THE WATER QUALITY STANDARD OR CCC VALUE.

5.14	2.46	0.70	44.8	0.286E+02	0.58
5.41	2.49	0.64	47.7	0.269E+02	0.60
5.68	2.53	0.58	50.6	0.253E+02	0.62
5.95	2.56	0.52	53.7	0.239E+02	0.63
6.22	2.59	0.46	56.7	0.226E+02	0.65
6.49	2.62	0.40	59.8	0.214E+02	0.67

END OF MOD122: STRONGLY DEFLECTED PLUME IN CROSSFLOW

BEGIN MOD131: LAYER BOUNDARY/TERMINAL LAYER APPROACH

CONTROL VOLUME

PROFILE DEFINITIONS:

BV = top-hat thickness, measured vertically
BH = top-hat half-width, measured horizontally in Y-direction
C = average (bulk) concentration
S = corresponding average (bulk) dilution
ZU = upper plume boundary (Z-coordinate)
ZL = lower plume boundary (Z-coordinate)

PREDICTION

X	Y	Z	S	C	B	BV	BH	ZU	ZL
CONTROL VOLUME INFLOW									
6.49	2.62	0.40	59.8	0.214E+02	0.67				
CONTROL VOLUME OUTFLOW									
7.83	2.62	0.00	101.7	0.126E+02	1.22	1.22	1.22	1.22	0.00

-END OF MOD131: LAYER BOUNDARY/TERMINAL LAYER APPROACH

_** END OF HYDRODYNAMIC MIXING ZONE (HMZ) ***

_BEGIN MOD141: BUOYANT AMBIENT SPREADING

PROFILE DEFINITIONS:

- BV = top-hat thickness, measured vertically
- BH = top-hat half-width, measured horizontally in Y-direction
- C = average (bulk) concentration
- S = corresponding average (bulk) dilution
- ZU = upper plume boundary (Z-coordinate)
- ZL = lower plume boundary (Z-coordinate)

PREDICTION: STAGE 1: NOT BANK ATTACHED

X	Y	Z	S	C	BV	BH	ZU	ZL
7.83	2.62	0.00	101.7	0.126E+02	1.22	1.22	1.22	0.00
66.25	2.62	0.00	162.5	0.788E+01	0.30	7.95	0.30	0.00
124.67	2.62	0.00	181.5	0.706E+01	0.21	12.36	0.21	0.00
183.09	2.62	0.00	193.8	0.661E+01	0.18	16.09	0.18	0.00
241.51	2.62	0.00	203.1	0.631E+01	0.15	19.42	0.15	0.00
299.93	2.62	0.00	210.7	0.608E+01	0.14	22.49	0.14	0.00
358.35	2.62	0.00	217.2	0.590E+01	0.13	25.36	0.13	0.00
416.77	2.62	0.00	222.8	0.575E+01	0.12	28.08	0.12	0.00
475.18	2.62	0.00	227.7	0.563E+01	0.11	30.67	0.11	0.00
533.60	2.62	0.00	232.2	0.552E+01	0.10	33.16	0.10	0.00
592.02	2.62	0.00	236.3	0.542E+01	0.10	35.55	0.10	0.00
650.44	2.62	0.00	240.0	0.534E+01	0.09	37.87	0.09	0.00
708.86	2.62	0.00	243.5	0.526E+01	0.09	40.12	0.09	0.00
767.28	2.62	0.00	246.8	0.519E+01	0.09	42.31	0.09	0.00
825.70	2.62	0.00	249.8	0.513E+01	0.08	44.44	0.08	0.00
884.12	2.62	0.00	252.7	0.507E+01	0.08	46.52	0.08	0.00
942.54	2.62	0.00	255.4	0.501E+01	0.08	48.56	0.08	0.00
1000.95	2.62	0.00	258.0	0.496E+01	0.07	50.55	0.07	0.00
1059.37	2.62	0.00	260.5	0.492E+01	0.07	52.51	0.07	0.00
1117.79	2.62	0.00	262.8	0.487E+01	0.07	54.43	0.07	0.00
1176.21	2.62	0.00	265.1	0.483E+01	0.07	56.32	0.07	0.00

_END OF MOD141: BUOYANT AMBIENT SPREADING

_BEGIN MOD161: PASSIVE AMBIENT MIXING IN UNIFORM AMBIENT

VERTICAL DIFFUSIVITY OF AMBIENT FLOW: EDIFFV = 0.008878 m**2/s
HORIZONTAL DIFFUSIVITY OF AMBIENT FLOW: EDIFFH = 0.323789 m**2/s

SIMULATION LIMIT BASED ON MAXIMUM SPECIFIED DISTANCE = 7000.00m.
THIS IS THE REGION OF INTEREST LIMITATION.

PROFILE DEFINITIONS:

- BV = Gaussian s.d. (46%) thickness, measured vertically
= or equal to layer depth, if fully mixed
- BH = Gaussian s.d. (46%) half-width, measured horizontally in Y-direction
- C = centerline concentration
- S = corresponding centerline dilution
- ZU = upper plume boundary (Z-coordinate)
- ZL = lower plume boundary (Z-coordinate)

XX

CORNELL MIXING ZONE EXPERT SYSTEM

_ORMIX1: Submerged Single Port Discharges EPA Version 1.40 (February 1992)

Original DESIGN CASE: summer weak east wind stratified

ITERATION number: 7

Start of iteration session: 5- 8-1998 14:24:37

ITE/CASE DESCRIPTION SUMMARY:

- Site name = Liberty-Development

Effluent discharger = BP

Pollutant = TSS

New DESIGN CASE = case7

New FILE NAME = case7

SUMMARY OF DISCHARGE CONDITIONS:

Distance to nearest bank	DISTB	=	7000 m
Nearest bank/shore		=	left
Port height	H0	=	2 m
Vertical angle	THETA	=	0 deg
Horizontal angle	SIGMA	=	90 deg
Port diameter	D0	=	.0508 m
Port area	A0	=	0.002027 m ²
Discharge flowrate	Q0	=	.00409 m ³ /s
Discharge velocity	U0	=	2.017760 m/s
Discharge density	RHO0	=	1028 kg/m ³
Effluent concentration	C0	=	1281
Concentration units		=	mg-per-litre

Program Element PARAM: Design Case: case7

Relative density differences between discharge and ambient:

The effluent density (1028 kg/m³) is greater than the surrounding ambient water density at the discharge level (1024 kg/m³).

Therefore, the effluent is negatively buoyant and will tend to sink towards the bottom.

Flow bulk parameters:

Discharge volume flux	Q0 = .00409 m ³ /s
Discharge momentum flux	M0 = 0.008253 m ⁴ /s ² .
Discharge buoyancy flux	J0 = -0.000157 m ⁴ /s ³ .

Flow length scales:

Discharge length scale	LQ = 0.045022 m
Jet crossflow length scale	Lm = 0.648886 m
Plume to crossflow length scale	Lb = 0.057098 m
Jet to plume transition length scale	LM = 2.187469 m

Non-dimensional parameters:

Densimetric Froude number	FR0 = 45.740257
Jet/Crossflow Velocity Ratio	R = 14.412572

Program Element CLASS: Design Case: case7

The near field flow configuration will have the following features:

The discharge near-field behavior is dominated by either the negative buoyancy of the discharge or the downward vertical orientation of the discharge port leading to bottom interaction.

The following conclusion on the flow configuration applies to a layer corresponding to the full water depth at the discharge site:

```

+-----+
      Flow class           NH4
      Applicable layer depth HS = 7 m
+-----+

```

BEGIN MOD101: DISCHARGE MODULE

PROFILE DEFINITIONS:

B = Gaussian 1/e (37%) half-width, normal to trajectory
C = centerline concentration
S = corresponding centerline dilution

PREDICTION

X	Y	Z	S	C	B
0.00	0.00	2.00	1.0	0.128E+04	0.03

END OF MOD101: DISCHARGE MODULE

BEGIN MOD111: WEAKLY DEFLECTED JET IN CROSSFLOW

CROSSFLOWING DISCHARGE

PROFILE DEFINITIONS:

B = Gaussian 1/e (37%) half-width, normal to trajectory
C = centerline concentration
S = corresponding centerline dilution

PREDICTION

X	Y	Z	S	C	B
0.00	0.00	2.00	1.0	0.128E+04	0.03
0.02	0.10	2.00	1.4	0.903E+03	0.04
0.04	0.21	2.00	1.8	0.697E+03	0.05
0.07	0.31	2.00	2.3	0.568E+03	0.06
0.11	0.42	2.00	2.7	0.479E+03	0.07
0.16	0.52	2.00	3.1	0.414E+03	0.09
0.21	0.63	2.00	3.5	0.365E+03	0.10
0.26	0.73	1.99	3.9	0.326E+03	0.11
0.33	0.84	1.99	4.4	0.294E+03	0.12
0.40	0.94	1.99	4.8	0.269E+03	0.13
0.47	1.05	1.99	5.2	0.247E+03	0.14

END OF MOD111: WEAKLY DEFLECTED JET IN CROSSFLOW

BEGIN MOD116: STRONGLY DEFLECTED JET IN CROSSFLOW

NOTE: THE WIDTH PREDICTION B IN THE FIRST ENTRY BELOW MAY EXHIBIT SOME MISMATCH (UP TO A FACTOR OF 1.5) RELATIVE TO THE LAST ENTRY OF THE PREVIOUS MODULE. THIS IS UNAVOIDABLE DUE TO DIFFERENCES IN THE WIDTH DEFINITIONS. THE ACTUAL PHYSICAL TRANSITION WILL BE SMOOTHED OUT.

PROFILE DEFINITIONS:

B = Gaussian 1/e (37%) half-width, normal to trajectory
C = centerline concentration
S = corresponding centerline dilution

PREDICTION

X	Y	Z	S	C	B
0.47	1.05	1.99	5.2	0.247E+03	0.21

3.70 2.15 1.61 35.6 0.360E+02 0.56

* WATER QUALITY STANDARD OR CCC HAS BEEN FOUND **
THE POLLUTANT CONCENTRATION IN THE PLUME FALLS BELOW THE WATER QUALITY STANDARD
OR CCC VALUE OF 0.30E+02 IN THE CURRENT PREDICTION INTERVAL.
THIS IS THE SPATIAL EXTENT OF CONCENTRATIONS EXCEEDING THE WATER QUALITY
STANDARD OR CCC VALUE.

5.87	2.45	1.45	50	27	
6.94	2.60	1.37	57.1	0.224E+02	0.71 ←
10.17	2.92	1.17	76.2	0.168E+02	0.82
13.40	3.17	0.98	94.0	0.136E+02	0.91
16.63	3.38	0.81	111.0	0.115E+02	0.99
19.87	3.57	0.65	127.5	0.101E+02	1.06
23.10	3.74	0.50	143.5	0.893E+01	1.12
26.33	3.90	0.36	159.2	0.805E+01	1.18
29.56	4.04	0.22	174.7	0.733E+01	1.24
32.79	4.17	0.09	190.0	0.674E+01	1.29

END OF MOD116: STRONGLY DEFLECTED JET IN CROSSFLOW

BEGIN MOD122: STRONGLY DEFLECTED PLUME IN CROSSFLOW

THIS FLOW REGION IS INSIGNIFICANT IN SPATIAL EXTENT AND WILL BE BY-PASSED.

END OF MOD122: STRONGLY DEFLECTED PLUME IN CROSSFLOW

BEGIN MOD131: LAYER BOUNDARY/TERMINAL LAYER APPROACH

CONTROL VOLUME

PROFILE DEFINITIONS:

BV = top-hat thickness, measured vertically

BH = top-hat half-width, measured horizontally in Y-direction

C = average (bulk) concentration

S = corresponding average (bulk) dilution

ZU = upper plume boundary (Z-coordinate)

ZL = lower plume boundary (Z-coordinate)

PREDICTION

X	Y	Z	S	C	B			
CONTROL VOLUME INFLOW								
32.79	4.17	0.40	190.0	0.674E+01	1.29			
X	Y	Z	S	C	BV	BH	ZU	ZL
CONTROL VOLUME OUTFLOW								
35.38	4.17	0.00	323.0	0.397E+01	2.17	2.17	2.17	0.00

END OF MOD131: LAYER BOUNDARY/TERMINAL LAYER APPROACH

** END OF HYDRODYNAMIC MIXING ZONE (HMZ) ***

BEGIN MOD141: BUOYANT AMBIENT SPREADING

PROFILE DEFINITIONS:

BV = top-hat thickness, measured vertically

BH = top-hat half-width, measured horizontally in Y-direction

C = average (bulk) concentration

S = corresponding average (bulk) dilution

ZU = upper plume boundary (Z-coordinate)
 ZL = lower plume boundary (Z-coordinate)

PREDICTION: STAGE 1: NOT BANK ATTACHED

X	Y	Z	S	C	BV	BH	ZU	ZL
35.38	4.17	0.00	323.0	0.397E+01	2.17	2.17	2.17	0.00
62.55	4.17	0.00	376.9	0.340E+01	1.37	4.02	1.37	0.00
89.72	4.17	0.00	407.7	0.314E+01	1.08	5.51	1.08	0.00
116.89	4.17	0.00	430.0	0.298E+01	0.92	6.82	0.92	0.00
144.07	4.17	0.00	447.7	0.286E+01	0.82	8.01	0.82	0.00
171.24	4.17	0.00	462.4	0.277E+01	0.74	9.12	0.74	0.00
198.41	4.17	0.00	475.2	0.270E+01	0.68	10.17	0.68	0.00
225.59	4.17	0.00	486.4	0.263E+01	0.64	11.16	0.64	0.00
252.76	4.17	0.00	496.4	0.258E+01	0.60	12.11	0.60	0.00
279.93	4.17	0.00	505.5	0.253E+01	0.57	13.03	0.57	0.00
307.10	4.17	0.00	513.9	0.249E+01	0.54	13.91	0.54	0.00

END OF MOD141: BUOYANT AMBIENT SPREADING

BEGIN MOD161: PASSIVE AMBIENT MIXING IN UNIFORM AMBIENT

VERTICAL DIFFUSIVITY OF AMBIENT FLOW: EDIFFV = 0.008878 m**2/s
 HORIZONTAL DIFFUSIVITY OF AMBIENT FLOW: EDIFFH = 0.050198 m**2/s

SIMULATION LIMIT BASED ON MAXIMUM SPECIFIED DISTANCE = 7000.00m.
 THIS IS THE REGION OF INTEREST LIMITATION.

PROFILE DEFINITIONS:

- BV = Gaussian s.d. (46%) thickness, measured vertically
 = or equal to layer depth, if fully mixed
- BH = Gaussian s.d. (46%) half-width, measured horizontally in Y-direction
- C = centerline concentration
- S = corresponding centerline dilution
- ZU = upper plume boundary (Z-coordinate)
- ZL = lower plume boundary (Z-coordinate)

PREDICTION: STAGE 1: NOT BANK ATTACHED

X	Y	Z	S	C	BV	BH	ZU	ZL
307.10	4.17	0.00	513.9	0.249E+01	0.54	13.91	0.54	0.00

PLUME INTERACTS WITH SURFACE

THE PASSIVE DIFFUSION PLUME BECOMES VERTICALLY FULLY MIXED WITHIN THIS PREDICTION INTERVAL.

976.39	4.17	0.00	23229.2	0.551E-01	7.00	48.47	7.00	0.00
1645.68	4.17	0.00	45472.3	0.282E-01	7.00	94.89	7.00	0.00
2314.97	4.17	0.00	72196.7	0.177E-01	7.00	150.65	7.00	0.00
2984.26	4.17	0.00	*****	0.125E-01	7.00	214.41	7.00	0.00
3653.55	4.17	0.00	*****	0.937E-02	7.00	285.24	7.00	0.00
4322.84	4.17	0.00	*****	0.737E-02	7.00	362.52	7.00	0.00
4992.13	4.17	0.00	*****	0.600E-02	7.00	445.73	7.00	0.00
5661.42	4.17	0.00	*****	0.500E-02	7.00	534.48	7.00	0.00
6330.71	4.17	0.00	*****	0.425E-02	7.00	628.46	7.00	0.00

SIMULATION LIMIT AS SPECIFIED HAS BEEN REACHED; PREDICTION TERMINATES AT THIS STAGE.

7000.00	4.17	0.00	*****	0.368E-02	7.00	727.37	7.00	0.00
---------	------	------	-------	-----------	------	--------	------	------

END OF MOD161: PASSIVE AMBIENT MIXING IN UNIFORM AMBIENT

APPENDIX J

EIS REPORTS PREPARED BY USGS AND FWS

- J-1* Estimating Potential Effect of Hypothetical Oil Spills from the Liberty Oil Production Island on Polar Bears
- J-2* Exposure of Birds to Assumed Oil Spills at the Liberty Project, Final Report

Estimating Potential Effect of Hypothetical Oil Spills from the Liberty Oil Production Island on Polar Bears

This appendix was published as part of the Liberty Development and Production Plan (DPP) Draft Environmental Impact Statement (EIS) and was not revised for the Final EIS. The reader is referred to this appendix in the Draft EIS. This appendix is also available on the CD-ROM (MMS 2002-019 CD) and on the Internet (<http://www.mms.gov/alaska/cproject/liberty>).

**ESTIMATING POTENTIAL EFFECTS OF HYPOTHETICAL OIL
SPILLS FROM THE LIBERTY OIL PRODUCTION ISLAND ON
POLAR BEARS**

Report to the Minerals Management Service for inclusion in the

Environmental Impact Statement

For

The Liberty Oil Production Island

Alaskan Beaufort Sea

Prepared by

Steven C. Amstrup

and

George M. Durner

U. S. Geological Survey, Alaska Science Center

Anchorage, Alaska

and

Trent L. McDonald

WEST, Inc.

Cheyenne, Wyoming

ESTIMATING POTENTIAL EFFECTS OF HYPOTHETICAL OIL SPILLS FROM THE LIBERTY OIL PRODUCTION ISLAND ON POLAR BEARS

ABSTRACT: The polar bear is the apical predator of the arctic, and may be among the most important indicators of general ecosystem health. Polar bears are most common near the continental shelf, an area also rich in extractable hydrocarbons. The goal of this project was to estimate the number of polar bears that might be oiled by a hypothetical spill from the Liberty Oil Production Island and sub-sea-floor pipeline in the central Beaufort Sea. We captured and radio-collared adult female polar bears throughout the Beaufort Sea and surrounding areas, and followed them by satellite telemetry. We used 10,913 re-observations of 289 females to estimate the distribution of polar bears in the Beaufort Sea. . We used, 255 observations of 69 polar bears and 322 observations of 95 polar bears to estimate the distribution of polar bears in the Liberty study area in September and October respectively. We assumed that other members of the population moved similarly to females. With kernel smoothing we estimated the number of bears likely to occur in each 1.00 km² cell of a grid superimposed over the area surrounding Liberty island. We estimated the standard errors of bear numbers per cell with bootstrapping. Oil spill footprints for October and September, the times during which we hypothesized effects of an oil-spill would be worst, were estimated using real wind and current data from 1980-1996. We used ARC/Info software to calculate overlap (numbers of bears oiled) between oil-spill footprints and polar bear grid-cell values. Numbers of bears potentially oiled by a 5912 barrel spill ranged from 0 to 25 polar bears for open water conditions, and from 0 to 61 polar bears in autumn mixed ice. Oil-spill trajectories affected small numbers of bears far more often than they affected larger numbers of bears. Median number of bears oiled by the 5912 barrel spill in September and October were 1 and 3 bears. In October, 75% of trajectories from the largest possible spill oiled 12 or fewer bears while 75% of the trajectories affected 7 or fewer polar bears in September.

INTRODUCTION

The polar bear is the apical predator of the arctic ecosystem and perhaps the universal symbol of the Arctic. Polar bears long have been an important subsistence resource. They also may be among the most important indicators of general health of the arctic ecosystem (Stirling and Derocher 1993). The distribution of polar bears is tied to that of sea ice in the Beaufort Sea region. They are most common in areas near the continental shelf where active ice over the deep water of the polar basin meets the shallow shelf water, and where there are persistent leads and openings suited to hunting seals. The continental shelf also is an important region for oil exploration and development (Stirling 1990). Spilled oil from continental shelf exploration projects could foul some of the most important foraging habitats of polar bears.

Because bears are known to consume foods (and non-food items) fouled with petroleum products, and because they groom intensively when their fur and environment are fouled, we can expect that a spill in the waters and ice of the continental shelf will result in contaminated polar bears. Spilled oil may be concentrated in pools on the ice surface and accumulate in leads and openings-that occur during spring break-up and autumn freeze-up (Neff 1990). Such mechanical concentration of spilled oil would increase the probability that polar bears and their principal prey (ringed seals, Phoca hispida) will be directly oiled. Also, the oiling of their prey suggests bears could be secondarily exposed to oil by consuming fouled prey.

Fortunately, there have been no marine oil spills in the 25+ years of arctic exploration and development. None the less, oil and other chemicals, can be fatal to exposed bears (Oritsland et al. 1981, Amstrup et al. 1989, St. Aubin 1990). Mortality levels that could be caused by oil spills have yet to be projected. Without such projections, preparations for and responses to spills, if they should occur, will be inadequate.

OBJECTIVES

The goal of this project was to estimate the number of polar bears that might be oiled by a hypothetical spill from the Liberty Oil Production Island and offshore pipeline in the central Beaufort Sea. Specific objectives are to:

1. Predict the geographic area that may be exposed to a variety of oil spill scenarios.
2. Develop probabilistic estimates of the numbers of bears that may be oiled by chosen scenarios.

METHODS

General Strategy

Radio-telemetry data showing the monthly distribution of polar bears was converted into estimates of density within the area surrounding Liberty Island. The paths of hypothetical oil spills were provided by the U. S. Minerals Management Service's Oil-Spill-Risk Analysis model (OSRA: Smith et al., 1982). This OSRA has been modified and updated substantially for this and other projects (Walter Johnson, unpublished). The general strategy used in this study was to: 1) calculate the probabilistic distribution of polar bears in our study area, 2) map the "footprints" of a series of oil-spill scenarios centered at Liberty Island, and 3) use GIS layering to overlap the oil-spill footprints with polar bear distributions to estimate the numbers of bears that would be exposed to oil in each scenario.

Spill Size, Timing, and Duration

The MMS evaluated the risks of oil being released from the transportation pipeline as well as from the drilling island itself, and estimated probable sizes of spills derived from those sources (Table 1). Probable leaks, based upon MMS review of oil leaks in similar environments, ranged from 125-5912 barrels (F. King, unpublished). Surprisingly, the largest probable releases of oil from Liberty

resulted from chronic rather than catastrophic events. Even the rupture of the sub-sea pipeline was estimated to result in the loss of only 1580 barrels of crude oil. Small chronic leaks in the pipeline during the ice covered period, however, could result in larger volumes of oil being released without detection. These large volumes, then, could be trapped under the ice until break-up in the spring. Failures in under ice detection could result in loss of as much as 2956 or 5912 barrels of oil depending on the failure scenario. Release of trapped oil during spring thaw would be equivalent to the catastrophic loss of these large volumes of oil. We recognized that spills this large may be less likely during open water time-frames. Because we were interested in evaluating the potentially worst oil-spill scenarios, however, we evaluated only 2956 and 5912 barrel spills, and treated them as if they were instantaneous discharges. We assumed that smaller spills would cover less area, contact fewer polar bears, and be less environmentally damaging.

When the southern Beaufort Sea (SBS) is covered by solid ice, spilled oil would remain trapped in the ice very near the source of release. Solid ice entrapment would guarantee minimal spread, and also maximize opportunities for clean-up and recovery of spilled oil. By way of contrast, maximum oil-spread would be most likely in open water. Polar bears, although less common than when ice is present, still occur near shore at this time. Finally, bear densities near shore are at their highest during the autumn broken ice period, and although hampered somewhat by ice, oil still could travel great distances. We therefore hypothesized the effects of an oil-spill, would be most severe during the open water period of maximum potential spread and during the mixed ice period of maximum polar bear density.

For the purposes of this report, we chose to model oil-spills occurring in two time frames. The first time frame extended from 22 August – 30 September. This coincided with the maximum extent of open water in the Southern Beaufort Sea, and should allow greatest spread of oil released from Liberty Island. The second time frame extended from 1 October – 9 November. This is the re-freezing period and coincides with the highest densities of bears in the near-

shore environment.

MMS provided trajectory data extending for periods of up to 6 months (in the case where oil may become trapped in winter ice). We, however, ran oil-spill trajectories for only 10 days. This time frame was chosen for three main reasons. First and foremost, we concluded that although we could follow oil spill paths indefinitely, the likelihood that our models would mimic real oil behavior seemed to diminish rapidly beyond the first several days post-spill. MMS calculations using the SINTEFF Oil Weathering Model (Reed et al. 2000) suggest that despite a high pour point and low evaporation potential, the nature of the oil product remaining beyond 10 days would be different than newly released oil. Also, the SINTEFF OWM does not incorporate the effects of wave action, currents, beaching, photo-oxidation etc, and has not been verified against field measurements beyond 4-5 days. After 10 days, therefore, we concluded that spreading of spilled oil would follow different rules than fresh crude. Finally, the volume of data we needed to evaluate was directly proportional to the length of time a spill scenario was allowed to run. Spill scenarios running longer than 10 days duration resulted in data sets that defied our analytical capabilities. Because they were less interpretable due to weathering etc., and because they created special analytical difficulties, there seemed little point in evaluating more protracted spill scenarios.

¹Estimates of Where an Offshore Oil Spill May Go

The MMS estimated how and where offshore spills may go with the modified OSRA (Smith et al., 1982). The OSRA model uses information about the physical environment, including files of wind, ice, and current data to predict the likely paths of oil spills. It also incorporates the locations of barrier islands and the coast. Oil spills are represented by numerous particles that are moved across the sea surface by wind, ice, and ocean current conditions. Approximately 500 spills or “trajectories” each composed of 500 hundred

¹ The discussion of oil-spill modeling is based upon documents provided by MMS. Tables 1,2, and Figures 1,2, were provided by MMS. Additional documentation of the MMS oil spill modeling approach can be found elsewhere in this EIS or in the cited MMS sources.

Lagrangian elements or particles (spillets) are simulated to give a statistical representation of possible oil transport. Each spillet moves under the influence of the range of wind, ice, and ocean-current conditions that exist in an area during a particular time-frame. OSRA assumptions include:

1. An oil spill is instantaneous.
2. An oil spill encapsulated in the fast ice does not move until the ice moves or it melts out.
3. Spreading is simulated through the dispersion of 500 spillets, each as a point with no mass or volume in the model.
4. The weathering of oil in spillets is estimated in the stand-alone SINTEF Oil Weathering Model (Reed et al. 2000).
5. The effects of weathering are not automatically incorporated into estimates of spillet behavior, but could be incorporated as descriptions of product remaining at any time-step in a trajectory.
6. Oil spills occur and move without any cleanup. The model does not simulate cleanup scenarios. The effects of any Oil Discharge Prevention and Contingency Plans must be analyzed separately.
7. Spillets stop when they contact the mainland coastline.
8. Oil spills are influenced by offshore barrier islands and currents adjacent to them, but OSRA does not allow spillets to stop upon contact with small barrier islands.

For cases where the ice concentration is below 80%, each trajectory is constructed using vector addition of the ocean current field and 3.5% of the instantaneous wind field—a method based on work done by Huang and Monastero (1982); Smith et al. (1982); and Stolzenbach et al. (1977). For cases where the ice concentration is 80% or greater, the model ice velocity is used to transport the oil. Equations 1 and 2 show the components of motion that are simulated and used to describe the oil transport for each spillet:

$$U_{oil} = U_{current} + 0.035 U_{wind} \quad (1)$$

or

$$U_{oil} = U_{ice} \quad (2)$$

where: U_{oil} = oil drift vector

$U_{current}$ = current vector (when ice concentration is less than 80%)

U_{wind} = wind speed at 10 meters above the sea surface

U_{ice} = ice vector (when ice concentration is greater than or equal to 80%)

The wind drift factor was estimated to be 0.035, with a variable drift angle ranging from 0° to 25° clockwise. The drift angle was computed as a function of wind speed according to the formula in Samuels et al. (1982). (The drift angle is inversely related to wind speed.) For the Beaufort Sea, the $U_{current}$ and U_{ice} are simulated using the two models described above. A random vector component is typically added to represent sub-grid scale uncertainty associated with turbulence or mixing processes that are not resolved by the physical transport processes of the general circulation model. This assures that each spillet moves differently than others despite being released at the same time and place.

Wind input for OSRA is derived from the TIROS Operational Vertical Sounder (TOVS) which has flown on NOAA polar-orbiting satellites since 1978. TOVS data from 1980 through 1996 were available for this modeling exercise. The TOVS Pathfinder (Path-P) dataset provides observations of areas poleward of latitude 60° N at a resolution of approximately 100 x 100 kilometers. The dataset is centered on the North Pole and has been gridded using an equal-area azimuthal projection, a version of the Equal-Area Scalable Earth-Grid (EASE-Grid) (Armstron and Brodzik, 1995).

Depending upon whether the location was within the stable shore-fast or off-shore ice, MMS used two general circulation models to simulate ocean current- and ice- vectors for the Liberty Project. Near-shore was defined as the

area lying approximately inshore of the twenty-meter bathymetric contour. This area is characterized by the most stable ice along this portion of the Beaufort Sea coast. Current vectors in this inshore region were simulated using a 2-dimensional hydrodynamic model developed by the National Oceanic and Atmospheric Administration (NOAA) (Galt, 1980, Galt and Payton, 1981). The 2-dimensional model incorporated the barrier islands in addition to the coastline. This model does not, however, have an ice module associated with it. MMS added an ice mask within the 0-meter and 20-meter water-depth contours to simulate the observed stable shorefast ice zone. The ice mask is assumed to have a 100% ice concentration. During the time the mask is applied, from November 1-June 15; neither ice nor spilled oil will move. When the mask is removed, oil moves as if in open water.

The inshore model is based on the wind forcing and the continuity equation. The model was originally developed to simulate wind-driven shallow water dynamics in lagoons and shallow coastal areas with complex shorelines. A finite element model determines the solutions where the primary balance is between the wind forcing friction, the pressure gradients, coriolis accelerations, and the bottom friction. The time dependencies are considered small, and the solution is determined by iteration of the velocity and sea level equations, until the balanced solution is calculated. The wind is the primary forcing function, and a sea level boundary condition of no anomaly produced by the particular wind stress is applied far offshore, at the northern boundary of the oil-spill-trajectory analysis domain. An example of the currents simulated by this model for a 10-meter/second wind is shown in Figure 1.

MMS compared the results of the model to current meter data from the Endicott Environmental Monitoring Program to determine if the model was simulating the first-order transport and the dominant flow. The model simulation was similar to the current-meter velocities during summer. Example time series from 1985 show the current flow at Endicott Station ED1 for the U (east-west) and V (north-south) components plotted on the same axis with the current derived from the NOAA model for U and V (Der-U and Der-V). The series shows

many events that coincide in time, and that the currents derived from the NOAA model are generally in good correspondence with the measured currents (Fig. 2). Some of the events in the measured currents are not particularly well represented, and that is probably due to forcing of the current by something other than wind, such as low frequency alongshore wave motions. Liberty Island is located within the inshore region. Spill trajectories that travel from inshore to offshore regions transit into an offshore model at the 20m contour.

Offshore the current vector and the oil drift vector are simulated using a 3-dimensional coupled ice-ocean hydrodynamic model (Hedström, Haidvogel, and Signorini, 1995; Hedström, 1994). The model is based on the semispectral primitive equation ocean model of Haidvogel, Wilkin, and Young, (1991) and the ice model of Hibler (1979). This model simulates flow properties and sea ice evolution in the western Arctic during 1983.

The ocean and ice models are forced by the fluxes of momentum and heat, estimated from the daily surface geostrophic winds and monthly thermodynamic fields. The location of each trajectory at each time interval is used to select the appropriate ice concentration. The pack ice is simulated as it grows and melts. The edge of the pack ice is represented on the model grid. Depending on the ice concentration, either the ice or water velocity with wind drift from the stored results of the Haidvogel, Wilkin and Young (1991) coupled ice-ocean model is used. A major assumption used in this analysis is that the ice-motion velocities and the ocean daily flows calculated by the coupled ice-ocean model adequately represent the flow components. Sensitivity tests and comparisons with data illustrate that the model captures the first-order transport and the dominant flow (Hedström, Haidvogel, and Signorini, 1995).

Estimation of Polar Bear Numbers

Field Procedures

We captured adult female polar bears throughout the Beaufort Sea and surrounding areas, for the purpose of deploying VHF and satellite (PTT) radio collars. Captures were accomplished by injecting immobilizing drugs with projectile syringes fired from helicopters (Larsen, 1971; Schweinsburg et al., 1982; Stirling et al., 1989). We did not radio-collar male polar bears because their necks are larger than their heads, and they do not retain radio collars. Capture protocols were approved by independent animal care and welfare committees. We captured and radio-collared polar bears in the Beaufort Sea and adjacent areas during spring and autumn 1981-1998. From 1981 to 1985, we used radio-collars transmitting at very high frequencies (VHF) and relocated collared bears by radio tracking from aircraft. After 1985, most collars we deployed were ultra high frequency (UHF) platform transmitter terminals (PTT's) that were relocated by satellite. Data retrieved from PTT's were processed by the Argos Data Collection and Location System (ADCLS; Fancy et al., 1988). Only data from PTT's were used for this study.

Analyses

We generated a population distribution based on locations of satellite radio-collared polar bears and estimates of polar bear population size for bears in western Canada, the southern Beaufort Sea, and the Chukchi Sea. Location data for polar bears equipped with satellite radio collars (PTTs) in the Beaufort and Chukchi Sea was collected from 1985 to the present date by USGS in Alaska and by the Canadian Wildlife Service in western Canada. We used only high quality satellite radio-locations that were within ≤ 1 km of the true location of the bear. PTTs had duty cycles that varied according to research objectives, ranging between a daily position fix to a weekly position fix. In order to standardize location data among different duty cycles, we selected only one high quality observation per week per satellite collar. Total population size for the study area was calculated as the sum of the best population estimates for the

northern Beaufort Sea (1200 bears), southern Beaufort Sea (1385 bears), eastern Chukchi Sea (1700 bears), and the western Chukchi Sea (1700 bears) (Wiig. et al. 1995)².

We estimated the number of polar bears present in each cell of the grid by smoothing and scaling the raw frequencies (ie. the actual radio-tracking locations) in each cell with a 2-dimensional Gaussian kernel smoother with fixed elliptical bandwidth (Wand and Jones, 1995). To do this, kernel estimates of the mean count in each cell were converted into density or intensity of use values by scaling the mean frequency counts such that they sum to one. The product of the population estimates and the intensity of use values determined from collared female bears provided estimates of the numbers of bears in each cell. Inherent in this procedure is the assumption that movement patterns of radio-collared females are comparable to those of unmarked polar bears.

Kernel smoothing made it possible to use existing data structure for predictive purposes without presuming any particular statistical distribution in the data. The 2-D Gaussian kernel smoother defines cell weights inside an ellipse of influence and then calculates a weighted average estimate of the number of locations in a particular cell. Ellipse orientations were computed by setting them equal to the major axis of influence in 2-dimensional correlograms computed from raw frequency counts. Each correlogram measured the correlation among cell counts as a function of distance between cells in all directions. In this southern Beaufort Sea (SBS) region, the 2-D correlogram showed that counts in cells equal distance offshore and separated by 100 km had an approximate correlation of 0.35. In contrast, cells separated by 25 km on a line perpendicular to shore had correlation of approximately 0.35. Hence, the major (long) axis of the ellipse of influence chosen for the SBS was oriented roughly parallel to the northeastern coast of Alaska. Calculation of kernel estimates using normal mathematical approaches was too computationally rigorous to be feasible with our large grid. To speed computations and increase efficiency of calculation, we employed Fast Fourier Transforms (Cooley and Tukey, 1965; Yfantis and Borgman, 1981).

We converted raw frequencies into density or intensity of use values by scaling the mean frequency counts such that they summed to one. Variation inherent in estimated intensity values was computed using bootstrap methods (Manly, 1997). Individual bears were randomly re-sampled with replacement. Each bear identification number with its associated number of locations was re-sampled by bootstrapping. In this way, once a bear was selected for inclusion into the bootstrap sample, all its observations were included together. This non-standard bootstrap sampling insured that time dependencies (i.e., auto-correlation), if present in the original data, also were present in each bootstrap sample. Because numbers of locations for each bear differed, each bootstrap sample was a different size. Once a bootstrap sample was selected, the entire estimation procedure was performed using the bootstrap data. We computed standard errors for each cell in the grid from the 500 bootstrap calculations of relative intensity of use. We then had point and interval estimates of the number of bears in each cell

We used the ARC/INFO (ver. 7.1.2, ESRI, Redlands, CA) GENERATE command to produce a point coverage of the coordinate file. Attribute data were read into an INFO template with the INFO ADD FROM command. The INFO template was then merged to the point coverage with the ARC/INFO JOINITEM command. The final point coverage of polar bear density included a point attribute table (PAT) of density and SE, a 7000 m distance between points and an area of 3584 X 3584 km.

Liberty island is centered at 70°16'45.3556" N. and 147°33'29.0891" W.. The Liberty Study Area was the area covered by a grid with 1024 by 256 or 262,144 total cells centered over Liberty Island. The Liberty study area then, is a subset of the Beaufort Sea, and represented a small proportion of the total extent of 4 polar bear populations that occur in the Chukchi and Beaufort Seas. In order to estimate the monthly distribution of polar bears in the Liberty Study area, we needed to determine how many of the bears from each of the four populations were present, in the smaller area. We applied a reduced grid where each cell was 1000m on a side or 1 km² to the Liberty area. This grid covered the region

from approximately Lonely to Flaxman Island and north of the Beaufort Sea coast for approximately 125 kilometers (see Figure 3). It extended 64 km south and 192 km north of Liberty. A north/south offset of the study area was imposed because polar bears typically do not occur on land and the focus of this project was oil spill effects on marine systems. An ARC/INFO polygon coverage of the study area boundary was created. Population size within the study area was determined by producing a new point coverage of bear density with the INTERSECT command, where all points that fell within the polygon boundary were included in the new point coverage. We used the STATISTICS command to summarize the density values of the new point coverage. We generated a new data set of polar bear satellite radio-locations (see above description) that fell within the study area. We then calculated a population density based on the estimated number of bears and the distribution of radio-collared bears within the study area by reapplying the Gaussian Kernel smoother to the data on the smaller grid. This produced an ARC/INFO point coverage of bear density in the study area.

ARC/INFO point coverages are computationally rigorous relative to raster-based GIS data. Therefore, we used the POINTGRID command to create raster grid cells with associated polar bear densities and standard errors (see also "Intersection of Oil-Spill Trajectories and Bear Densities"). Oil spill paths were estimated to have a maximum spread diameter of 47 m (Table 2). Therefore, only a small proportion of any 1km polar bear density cell would be intersected by the narrow spill path, and we felt it would be unreasonable to count an entire 1 km² density cell as oiled. To prevent this possible overestimation, the grid was further partitioned in order that the proportion of a cell, rather than the entire cell, might be counted as oiled. We used ARC/INFO GRID module commands to subdivide each cell. We performed 2 subdivisions. We first generated a grid in which each 1km² cell was divided into 400 smaller (50 X 50 m, or 2500 m²) cells. Then we subdivided the 1km² cells into 1600 cells measuring 25X25m.

Intersection of Oil-Spill Trajectories and Bear Densities

The oil-spill trajectories provided were linear paths or arcs showing how wind and current forcing moved each spillet around. Because spilletts represented volumes of oil that have mass, however, the arcs could be converted to polygons by incorporating the expected spreading, over the surface of the water, for that volume of oil. For example, each of the 500 spilletts from a spill of 1500 barrels would represent 3 barrels of oil and would spread to a diameter of ~26m (Table 2). By overlaying the aerial extent of spillet polygons with our grid of bear densities and standard errors, we could determine the number of grid cells and the numbers of bears oil would contact. While this might have been the most intuitive estimate of the number of bears oiled, the overlay of polygons with our grid proved to be too computationally rigorous. With 500 trajectories to run for each scenario, and 500 spilletts for each trajectory, we had to develop a computationally more efficient method. To efficiently mimick the outcome of the overlay procedure, we converted line coverages of oil spill trajectories to individual raster grids with 25 m and 50 m cell sizes. We used GRID commands to create a bear density grid and a SE grid for each trajectory by assigning density and SE values to trajectory grid cells. We assigned values by matching each cell center of the trajectory grid with the closest cell center from the bear density or SE grid (Figure 4). Density and SE values of each trajectory grid were exported as an ASCII text file for analysis.

Each of the 500 spilletts was composed of hourly arc segments. The arc attribute table (AAT) of trajectory coverages included: ID (identifies an hourly arc segment of a spillet by the trajectory number, spillet number, and hourly increment); TRAJ (the trajectory identifier); SPILLET (spillet identifier); YEAR (year of data used to generate the oil spill scenario); JDAY (julian day of data used to generate the oil spill scenario); HOUR (hour of the day, from 1 – 24); and ICE_PCT (percent ice coverage for that particular spillet segment). We used the INFO command REDEFINE to create a new field of hourly increments in the AAT. This new field (labeled INTERVAL), allowed us to select trajectories falling entirely in a targeted timeframe. Individual trajectories were extracted from the

master coverage and saved as individual trajectory line coverages.

Estimation of the number of polar bears potentially effected by an oil spill at Liberty Island required the polar bear density grid, the polar bear standard error grid, and the rasterized “polygon coverage” of spill paths. All polar bear grid cells that were touched or crossed by one or more cell of a rasterized spill path were considered ‘oiled’ by a spill. Each polar bear grid cell could be oiled only “once” per trajectory. The bears estimated to populate each grid cell were considered to be killed-that is there were no partial effects of oiling allowed. One estimate of the number of polar bears impacted by one oil spill resulted from each overlap of a rasterized trajectory with the polar bear density grid. Because each trajectory was simulated under different and independent weather and sea state conditions, the 500 trajectories were regarded as a simple random sample of oil spills from a larger (infinite) population of oil spills that might occur in the future.

Random errors inherent in the oil spill paths composing trajectories were independent and variation across independent trajectories correctly incorporated variation in spill paths. Five hundred records of the overlap of density grids and trajectories revealed the variation (in numbers of polar bears potentially oiled) that resulted from differing wind, current, and ice conditions, among spill occasions (trajectories). These 500 trajectories, however, could not elucidate the variation contributed by the standard errors in estimation of polar bear cell values. We evaluated the contribution of those errors with Monte Carlo simulation as follows: Assuming m_{ij} represents the estimated mean density of polar bears in cell i,j and s_{ij} represents the estimated standard error of m_{ij} , the Monte Carlo simulations estimated the contribution of variation within bear cells using the following scheme:

1. For each cell hit by oil during a single spill, a random deviate from a gamma distribution with mean m_{ij} and standard deviation s_{ij} was generated. Let g_{ij} represent this gamma deviate.
2. The random gamma deviates were summed over all cells hit by oil to

estimate number of impacted bears.

3. For each trajectory, steps 1 and 2 were repeated 10 times providing 10 Monte Carlo realizations of the number of potentially impacted polar bears for each trajectory.

The 5000 Monte Carlo trajectories (10 iterations of 500 trajectories) allowed us to determine the portion of the variance, in estimated number of bears affected by an oil spill, that resulted from differences within and among trajectories.

We assumed the gamma distribution for mean densities because: (1) the gamma distribution does not allow negative density values to be generated, and (2) the gamma distribution is uni-modal resembling a normal distribution when its standard error is small relative to its mean. An alternative choice of distribution for average bear density was the normal distribution, but the normal distribution admits negative densities. To investigate the sensitivity of estimated standard errors to the assumed distribution of average density, we also calculated standard errors assuming the normal distribution. Normal deviates below zero were truncated to zero for this comparison.

Spatial correlation among locations in neighboring grid cells was accounted for and used in the smoothing process that estimated average densities. The smoothing process accounted for spatial correlation in locations by averaging cell values in a local neighborhood of cells to arrive at density estimates. While the density estimates, m_{ij} , were spatially correlated, the error inherent in estimating the m_{ij} was not expected to be correlated with errors in adjacent cells. Spatial dependency of estimation error, and of the g_{ij} , was not incorporated into the Monte Carlo estimate of standard error. Each g_{ij} was generated independently of every other g_{ij} .

To illustrate the computations, consider the hypothetical grid of estimated polar bear densities and standard errors in Table 3. Also consider the indicators of which cells were oiled in Table 4. In this example, cells (1,2), (1,3), (2,1), (2,2), and (3,1) received oil. The estimated number of polar bears impacted in

this example is the sum of polar bear densities from the five cells indicated in Table 2, or 0.065 bears ($=0.015+0.02+0.01+0.005+0.015$). Three iterations of the Monte Carlo variance estimation procedure are contained in Table 5. Each Monte Carlo iteration generated gamma deviates only for those cells that were oiled. The estimated number of impacted bears from the 3 iterations were 0.0634, 0.0604, and 0.0633. The reported standard error for the estimated number of impacted bears was the standard deviation of these three numbers, 0.0017.

Once Monte Carlo simulations were complete, the total variation in number of oiled bears was partitioned into two sources following standard ANOVA methods for random effects models. Total variation in oiled bears was partitioned into a component due to variation across trajectories and a component due to variation within trajectories. Following Neter et al. (1990, equations 26.16a through 26.16d), total sum-of-squares was computed as

$$SSTO = \sum_{i=1}^t \sum_{j=1}^n Y_{ij}^2 - (Y_{..}^2 / tn)$$

where t = number of trajectories, n = number of Monte Carlo iteration per trajectories, Y_{ij} = the estimate of number of bears oiled by the i -th trajectory during the j -th Monte Carlo simulation, and

$$Y_{..} = \sum_{i=1}^t \sum_{j=1}^n Y_{ij} .$$

The sum-of-squares attributable to variation among trajectories was computed as

$$SSA = \sum_{i=1}^t Y_{i.}^2 / n - (Y_{..}^2 / tn)$$

where

$$Y_{i.} = \sum_{j=1}^n Y_{ij} .$$

The proportion of variation due to trajectories (R^2) was computed as $SSA/SSTO$. If SSA was a large proportion of $SSTO$, variation across trajectories was large and variation within trajectories was small.

RESULTS

Estimation of Polar Bear Density

We utilized 10,913 satellite radio-observations of 289 polar bears to establish distributions of polar bears in the Beaufort Sea. Of those, 255 observations of 69 polar bears were used to estimate the distribution of polar bears in the Liberty study area during the open water period of 22 August to 30 September (hereafter called September). Similarly, we used 322 observations of 95 polar bears to generate the 1 October to 9 November (hereafter called October) distribution of polar bears in the Liberty area.

Kernel smoothing of these observations provided probabilistic distributions of polar bears to overlay with the oil-spill trajectories. Final products depicting polar bear distributions in the study area included the estimated number of bears (actually fractions of a bear) and the standard error of those estimated numbers in each cell of our grid. For presentation and interpretation purposes, we developed contour bands showing variation in monthly intensity of polar bear use over the whole study area. The distribution was not uniform during either the open water or October time frames (Figures 5, 6).

During September, polar bears generally were more scattered than they were in October. Pockets of relatively high density, such as near Kaktovik, reflected areas where polar bears frequent the beach in open water times. Also, they occurred in greater numbers farther north, presumably due to higher concentrations of broken ice in northern reaches of the study area (Figure 5). As our empirical observations suggested; October polar bear densities along the coast were very high. Peak October densities occurred just north of Liberty Island (Figure 6), and were nearly an order of magnitude greater at the island

than in September. Overall, near shore densities of polar bears were 2 to 5 times greater in October than in September. Figures 7 and 8 reveal that near-shore densities in February and June were intermediate between those of October and September. Density gradients also were less severe in February and June. These results verified that the times of greatest impact from an oil spill were likely to be summer and fall.

Oil-Spill Trajectories

Footprints of the 2000 oil spill trajectories we modeled were highly variable (Table 6, Figures 5, 6,). Trajectories simulating the 5912 barrel spill in September, swept over as little as 3 km² and as much as 1645 km² during the 10-day time-frame specified for the spill (Figure 9). The mean area affected was 359 km², while the median value was 188 km². In October, minimum and maximum footprints of a 5912 barrel spill were 2.8 km² and 1534 km² (Figure 13). The mean and median were 238 km² and 89 km² respectively. As expected, smaller spills contacted smaller areas. However, it should be noted that reducing the spill volume by half did not reduce the oiled area by half (Figures 9, 11, 13, 15). On average, oil drifted somewhat farther in September than it did in October, possibly reflecting the influence of reforming sea-ice on oil movement in October (Table 6, Figures 9, 11, 13, 15).

Intersection of Oil-Spill Trajectories and Bear Densities

Variable oil-spill footprints translated into varying numbers of polar bears potentially affected by each spill trajectory. The high densities of polar bears projected for the near coastal regions of the SBS in October occasionally corresponded with large numbers potentially being exposed to oil (Table 6). Because the distribution of polar bears in the study area was not uniform, the relationship between spatial coverage and number of bears affected was not perfect. Depending upon which direction and how far a particular trajectory traveled, numbers of bears affected varied greatly (Figures 5, 6). Trajectories simulating the 5912 barrel spill in September, oiled as few as 0.007 bears and as many as 25 bears. The mean number affected was 4, while the median value

was 1 bear. In October, minimum and maximum numbers of bears oiled by the 5912 barrel spill were 0.05 and 60. The mean and median were 9.5 and 2.9 bears respectively (Table 6). Smaller spill volumes affected fewer bears, but As in comparisons of spatial coverages the change in numbers of bears affected was not equivalent to the change in volume (Figures 10, 12, 14, 16).

We used two Monte Carlo simulations to examine the variation in the bear cell values. One was based upon a gamma distribution and the other on a Normal truncated at zero. In all cases, no practical differences were seen between standard errors calculated assuming a gamma distribution and those calculated assuming a normal distribution. These estimates typically differed in their 3rd decimal place only (Table 7). The variation in our estimates of numbers of bears oiled was due almost entirely to variation among trajectories. Variation within trajectories did not contribute except at the 10,000th or 100,000th decimal place (Table 7).

DISCUSSION

The maximum numbers of bears potentially oiled during both the September open water and October broken ice scenarios were large (25 and 60). During both scenarios, however, oil-spill trajectories affected small numbers of bears far more often than they affected larger numbers of bears (Tables 2, Figures 10, 12, 14, 16). For example, in October, the median number of bears killed by a 5912 barrel spill was only 3 (Table 6), the minimum rounded to 0 and the maximum was 60. In October, 404 trajectories simulating a 5912 barrel spill killed 20 or fewer bears. 75% of the trajectories killed 12 or fewer bears. The distribution of oiled bears is highly skewed to the right with median numbers of bears oiled constituting only 1/3rd to 1/4th of the mean.

Our estimates of the numbers of bears that might be oiled at Liberty Island incorporate geographic uncertainty in our estimates of polar bear occurrence. Monte Carlo simulations verified that the uncertainty due to distribution of bears

is inconsequential. Estimates of numbers of bears oiled, however, do not include any measure of the uncertainty in our population estimates. The Liberty study area is entirely within the range of the SBS polar bear population. However, some number of bears from the Northern Beaufort Sea, Eastern Chukchi Sea, and the Western Chukchi Sea populations could be within the bounds of the study area at any time. Amstrup and McDonald (In Prep.), and McDonald and Amstrup (2000) have shown that the population of the SBS (which we estimated at 1385 for this exercise) might be as small as 1000 or as large as 2300. No comparable estimates are available for the other populations. None the less, because the Liberty study area is within the SBS region, it might be fair to conclude that the population in question might be as small as 72% or as large as 170% of the value we used in our computations. Those multipliers could be applied directly to the column values in hour histograms (Figures 10,12,14,16), or to the quantile values shown in table 6. For example, using the upper most point in our interval estimate; we could calculate that the median number of bears that could be affected by a 5912 barrel spill in October would be 4.2 (2.87×1.7). Similar multipliers could be applied across the board to calculate least and most damaging extremes.

Managers, regardless of the scenario entertained, still are faced by the very low probability that a large number of bears might be affected and the high probability that a low number of bears will be affected. In the public's mind, a spill that killed 60 bears would be regarded as a major environmental disaster just as would a spill that killed 100 bears. Similarly, spills that kill 0.063 (1.7×0.0037) bears and spills that kill 0.0037 bears would likely hold the same place in the public eye. Hence, evaluating the best and worst case scenarios may be of mathematical and statistical interest, but it is of little practical consequence.

Depending upon prevailing environmental conditions at the time, the spilling of 2956 or 5912 barrels of crude oil from Liberty Island could pose significant risks to polar bears, or essentially no risk at the population level.

Ultimately, the calculation of risks to polar bears from an oil spill at Liberty Island, or any where else, must incorporate not only the risk to bears once a spill occurs, but the probability of occurrence of a spill. In Alaska, oil production is accompanied by stipulations for clean-up efforts. The strength of those stipulations and the realistic assessment of their effectiveness must also be included in any adequate risk analysis. With the probabilistic assessments of polar bear/oil interactions provided here, industry and agency managers are one step closer to being able to perform that risk assessment.

REFERENCES

- Amstrup, S. C., C. Gardner, K.C. Myers, and F. W. Oehme. 1989. Ethylene glycol (antifreeze) poisoning of a free-ranging polar bear. *Vet. Hum. Toxicol.* 31:317-319.
- Amstrup, S. C., and T. L. McDonald. (In Prep). Polar bears in the Beaufort Sea: A 30 Year Mark-recapture Case History.
- Armstrong, R.L. and M.J. Brodzik, 1995. An Earth-Gridded SSM/I Data Set For Cryospheric Studies And Global Change Monitoring. *Advanced Space Research* 16:155-163.
- Cooley, J. W. and Tukey, J. W., 1965. An algorithm for the machine calculation of complex Fourier Series, *Mathematics of Computation*, vol. 19, pp 297-301, April, 1965.
- Cressie, N. A. C. (1991) *Statistics for spatial data*. New York: John Wiley and Sons.
- Fancy, S. G., Pank, L. F., Douglas, D. C., Curby, C. H., Garner, G. W., Amstrup, S. C., and Regelin, W. L. 1988. Satellite Telemetry: a new tool for wildlife research and management. *Resour. Publ.* 172. USDI, Fish and Wildlife Service, Wash. D. C. 54 pp.
- Galt, J.A. 1980. A Finite-Element Solution Procedure for the Interpolation of Current Data in Complex Regions. *Journal of Physical Oceanography* 10(12): 1984-1997.

- Galt, J.A. and Payton, D.L. 1981. Finite-Element Routines for the Analysis and Simulation of Nearshore Currents. *In* Comptes Rendus du Colloque, Mechanics of Oil Slicks. Paris, September 5-9. International Association for Hydraulic Research. Pp. 121-132
- Haidvogel, D.B., J.L. Wilkin, and R. Young. 1991. A Semi-Spectral Primitive Equation Ocean Circulation Model Using Vertical Sigma and Orthogonal Curvilinear Horizontal Coordinates. *Journal of Computational Physics* 94:151-185.
- Hedstrom, K.S. 1994. Technical Manual for a Coupled Sea-Ice/Ocean Circulation Model (Version 1). Technical Report. OCS Study, MMS 94-0001. Anchorage, AK: USDO, MMS, Alaska OCS Region, 53 pp.
- Hedstrom, K.S., D.B. Haidvogel, and S. Signorini. 1995. Model Simulations of Ocean/Sea-Ice Interaction in the Western Arctic in 1983. OCS Study, MMS 95-0001. Anchorage, AK: USDO, MMS, Alaska OCS Region, Environmental Studies Program.
- Hibler, W.D.I. 1979. A Dynamic Thermodynamic Sea Ice Model. *Journal of Physical Oceanography* 9:815-846.
- Huang, J.C. and F.M. Monastero. 1982. Review of the State-of-the-Art of Oilspill Simulation Models. Washington, DC: American Petroleum Institute.
- Larsen, T. 1971. Capturing, handling and marking polar bears in Svalbard. *J. Wildl. Manage.* 35: 27-36.

- Manly, 1997, "Randomization, Bootstrap and Monte Carlo Methods in Biology", 2nd ed. Chapman and Hall.
- McDonald, T. L., and S. C. Amstrup. 2000. Estimation of population size using open capture-recapture models. *J. Agricultural Biological, and Environmental Statistics*. In Press.
- Neff, J. M.. 1990. Composition and fate of petroleum and spill-treating agents in the marine environment. Pages 1-33. In J. R. Geraci and D. J. St. Aubin. eds. *Sea mammals and oil: confronting the risks*. Academic Press, San Diego, CA.
- Neter, J., W. Wasserman, and M. H. Kutner. 1990. *Applied Linear Statistical Models*. 3rd Edition. Irwin Press, Burr Ridge, Illinois. 1181pp.
- Neter, J., W. Wasserman, and M. H. Kutner. 1990. *Applied Linear Statistical Models*. 3rd Edition. Irwin Press, Burr Ridge, Illinois. 1181pp.
- Oritsland, N. A., F. R. Engelhardt, F. A. Juck, Hurst, R. A., and P. D. Watts. 1981. Effects of crude oil on polar bears. *Environ. Stud. Rep. No. 24*. Northern Affairs Program, Dept. of Indian Affairs and Northern Development, Ottawa, Ontario, Canada.
- Reed, M., N. Ekrol, P. Daling, O. Johansen, M.K. Ditlevsen, and I. Swahn. 2000. *SINTEF Oil Weathering Model User's Manual, Version 1.8*. Trondheim, Norway: SINTEF Applied Chemistry, 38 pp.
- Samuels, W.B., N.E. Huang, and D.E. Amstutz. 1982. An Oilspill Trajectory Analysis Model With a Variable Wind Deflection Angle. *Ocean Engineering* 9(4):347-360.

- Schweinsburg, R. E., Lee, L. J., and Haigh, J. C. 1982. Capturing and handling polar bears in the Canadian Arctic. In Chemical immobilization of North American wildlife. Edited by L. Nielsen, J. C. Haigh, and M. E. Fowler. Wis. Humane Society Inc., Milwaukee. pp. 267-289.
- Smith, R.A., J.R. Slack, T. Wyant, and K.J. Lanfear. 1982. The Oilspill Risk Analysis Model of the U.S. Geological Survey. Geological Survey Professional Paper 1227. Washington, DC: U.S. Government Printing Office, 40 pp.
- St. Aubin, D. J. 1990. Physiologic and toxic effects on polar bears. Pages 235-239. In J. R. Geraci and D. J. St. Aubin. eds. Sea mammals and oil: confronting the risks. Academic Press, San Diego, CA.
- Stirling, I., Spencer, C., and Andriashek, D. 1989. Immobilization of polar bears (Ursus maritimus) with telazol in the Canadian Arctic. J. Wildl. Diseases, 25: 159-168.
- Stirling, I. 1990. Polar bears and oil: ecologic perspectives. Pages 223-234. In J. R. Geraci and D. J. St. Aubin. eds. Sea mammals and oil: confronting the risks. Academic Press, San Diego, CA.
- Stirling, I., and A. E. Derocher. 1993. Possible impacts of climatic warming on polar bears. Arctic. 46: 240-245.
- Stolzenbach, K.D., S. Madsen, E.E. Adams, A.M. Pollack, and C.K. Cooper. 1977. A Review and Evaluation of Basic Techniques for Predicting the

- Behavior of Surface Oil Slicks. Report No. MITSG 77-8. Cambridge, MA:
MIT Sea Grant Program, 322 pp.
- Wand, M. P., and M. C. Jones. Kernel Smoothing. Monographs on Statistics
and applied probability No. 60. 212pp.
- Wiig, O., E. W. Born, and G. W. Garner eds. 1995. Polar Bears. Occas. Pap.
IUCN Species Survival Commission 10:24.
- Yfantis, A. and Borgman, L. E. 1981. Fast Fourier Transforms 2-3-5. Computers
and Geosciences. Vol 7 No. 1. pg 98-108.
- Zar, J. H. 1984. Biostatistical analysis. 2nd edition. Prentice-Hall, Inc.
Englewood Cliffs, N. J. 718 pp.

Table 1: Periods of Interest, Spill Size in barrels of oil, and Average Environmental Conditions assumed for Weathering Simulations.

	<i>Period of Interest</i>	Open Water Spill Sizes	Open Water Average Conditions for Sea Surface Temperature and Wind Speed	Melt Out Spill Sizes	Melt Out Average Conditions for Sea Surface T and Wind Speed
1	1 June – 1 July	102, 125, 925, 1580	1 ⁰ C and 5m/s	125, 715, 925, 1580, 2956, 5,912	0 ⁰ C and 5m/s
2	15 June – 15 July	102, 125, 925, 1580	2 ⁰ C and 6m/s	125, 715, 925, 1580, 2956, 5,912	0 ⁰ C and 5m/s
3	1 July – 1 August	102, 125, 925, 1580	2 ⁰ C and 6m/s	125, 715, 925, 1580, 2956, 5,912	0 ⁰ C and 5m/s
4	1 August – 1 September	102, 125, 925, 1580	2 ⁰ C and 6m/s	125, 715, 925, 1580, 2956, 5,912	0 ⁰ C and 5m/s
5	1 September – 1 October	102, 125, 925, 1580	1 ⁰ C and 6m/s	125, 715, 925, 1580, 2956, 5,912	0 ⁰ C and 5m/s
6	15 September – 15 October	102, 125, 925, 1580	1 ⁰ C and 6m/s	125, 715, 925, 1580, 2956, 5,912	0 ⁰ C and 5m/s
7	15 October – 15 November	102, 125, 925, 1580	-2 ⁰ C and 6m/s	125, 715, 925, 1580, 2956, 5,912	0 ⁰ C and 5m/s

Note: Environmental Data was taken from Brower et al. 1988 and Endicott Environmental Monitoring Program CTD and Meteorological Station Data (1985-1990).

Table 2: Diameters of oil spilletts used for modeling the movement of oil released from Liberty island. Each of approximately 500 spill trajectories was composed of 500 Spilletts that represented equal aliquots of oil from that spill. Hence, each of the 500 spilletts from a 1500 barrel spill would be 3 barrels in size.

Spill Size in Barrels	Spillet Size in Barrels	Calculated Spillet Diameter in Meters	Rounded Spillet Diameter In Meters	Thickness in Meters
125	0.25	9.437208	9	0.000543
715	1.43	19.4299	19	0.000726
925	1.85	21.63061	22	0.000757
1,500	3	26.45743	26	0.000821
1,580	3.16	27.03648	27	0.000828
2,956	5.912	35.09968	35	0.000919
5,912	11.824	46.85245	47	0.001032

Table 3: A hypothetical grid of estimated polar bear densities and standard errors. Standard errors are in parentheses.

Row #	Column #			
	1	2	3	4
1	0.010 (0.001)	0.015 (0.002)	0.020 (0.010)	0.015 (0.005)
2	0.010 (0.009)	0.005 (0.002)	0.010 (0.004)	0.015 (0.008)
3	0.015 (0.005)	0.005 (0.001)	0.010 (0.005)	0.020 (0.014)
4	0.010 (0.008)	0.010 (0.006)	0.015 (0.007)	0.010 (0.006)

Table 4: A hypothetical grid indicating which cells were oiled in an example illustrating computation of number of impacted polar bears. '1' = cell received some amount of oil during the hypothetical oil spill. '0' = cell did not receive oil.

Row #	Column #			
	1	2	3	4
1	0	1	1	0
2	1	1	0	0
3	1	0	0	0
4	0	0	0	0

Table 5: Three example iterations from the Monte Carlo standard error estimation procedure. Values in each iteration generated from a gamma distribution.

Cell	Monte Carlo Iteration		
	1	2	3
1,2	0.0133	0.0146	0.0146
1,3	0.0119	0.0224	0.0149
2,1	0.0161	0.0041	0.0089
2,2	0.0052	0.0048	0.0043
3,1	0.0168	0.0145	0.0207
Total:	0.0634	0.0604	0.0633
Standard deviation of totals: 0.0017			

Table 6. Summary of numbers of bears and areas potentially contacting oil released during simulated spills in the Liberty Island area of the southern Beaufort Sea . We ran 500 trajectories for each scenario or time frame. Each trajectory was comprised of 500 spilletts or Lagrangian elements. Numbers of bears oiled by each trajectory were resampled with Monte Carlo methods 10 times. Note that in all scenarios, the vast majority of trajectories influenced relatively small numbers of bears. Particularly in October, however, a small number of trajectories oiled very large numbers of bears.

Trajectory	Area Oiled by Spills from Liberty Island (Km)									
	Time Period	Mean	Min	Max	S.E.*	5%	10%	25%	Median	75%
October 50m	238	2.84	1534	344	7.9	10.2	27.3	88.9	270	1171
October 25m	198	2.3	1110	280	7.1	9.2	24.6	74.3	232	973
September 50m	359	3.1	1645	374	11.3	13.2	33.8	188.3	606	1002
September 25m	290	2.7	1193	292	10.1	11.8	29.9	165.2	494	827
Numbers of Bears Oiled by Spills from Liberty Island										
October 50m	9.53	0.046	60.46	13.6 (4.6)	0.12	0.17	0.66	2.87	11.77	39
October 25m	7.98	0.037	50.53	11.3(4.2)	0.11	0.16	0.59	2.48	10.2	32.57
September 50m	4.03	0.007	24.93	5.4 (4.7)	0.03	0.04	0.11	1.01	6.74	15.12
September 25m	3.21	0.005	18.95	4.2 (4.2)	0.02	0.03	0.1	0.82	5.56	11.56
NUMBER OF BEARS OILED PER SQUARE KILOMETER OILED										
October 50m	0.04	0.0162	0.0394		0.0152	0.0167	0.0242	0.0323	0.0436	0.0333
October 25m	0.0403	0.0161	0.0455		0.0155	0.0174	0.024	0.0334	0.044	0.0335
September 50m	0.0112	0.0023	0.0152		0.0027	0.003	0.0033	0.0054	0.0111	0.0151
September 25m	0.0111	0.0019	0.0159		0.002	0.0025	0.0033	0.005	0.0113	0.014

*Standard Errors in () are for the subset of trajectories in which 20 or fewer bears were oiled.

Table 7. Contribution to variation in estimated numbers of polar bears affected by different sizes and time frames of oilspills. Mean and standard error of approximately 5000 simulation runs. Note that the variation in cell values for polar bear numbers contributes essentially nothing to the variation among spill trajectories.

Trajectory	No.	Mean Gamma	Mean Normal	S.E. Gamma	S. E. Normal	SS Across Trajectories	SS Within Trajectories	SS Total	% Due to Trajectories
October 50m	4950	9.53	9.53	13.569	13.569	911302	0.22304	911302	99.99998
October 25m	4950	7.98	7.98	11.255	11.255	626922	0.04525	626922	99.999993
September 50m	5000	4.03	4.03	5.398	5.399	145679	0.07306	145679	99.99995
September 25m	5000	3.21	3.22	4.211	4.212	88668	0.01376	88668	99.999984

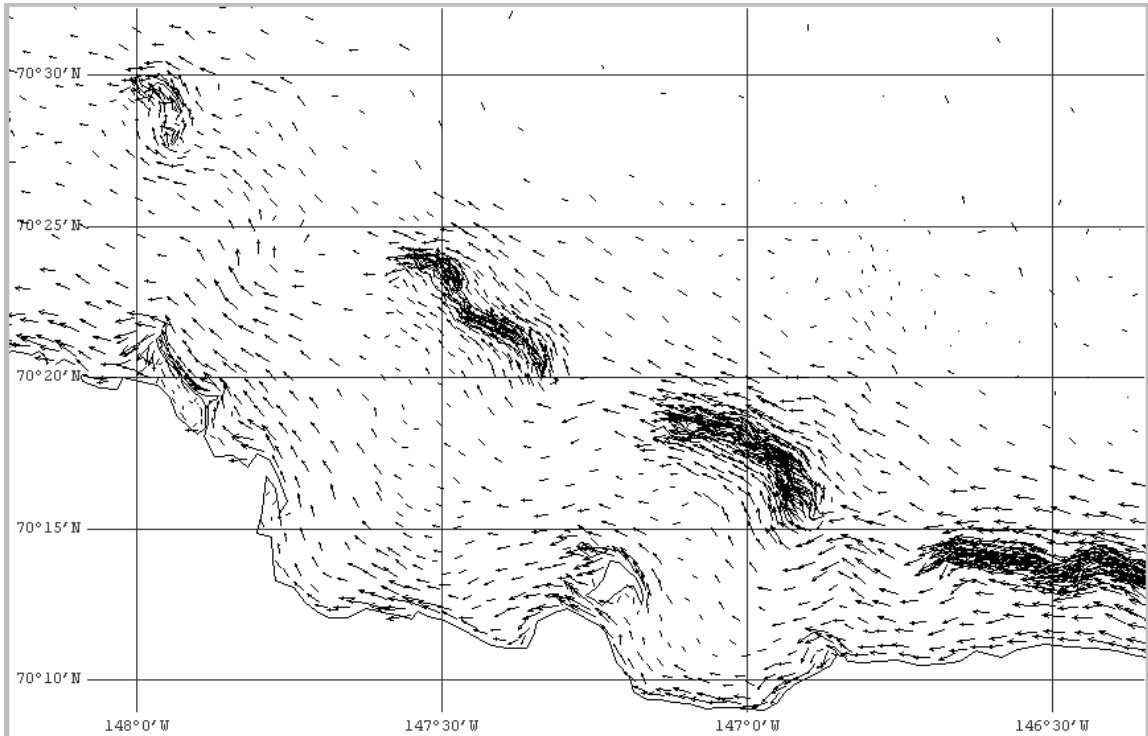

Figure 1 Nearshore surface currents simulated by the NOAA model for a wind from the East at 10meters/second.

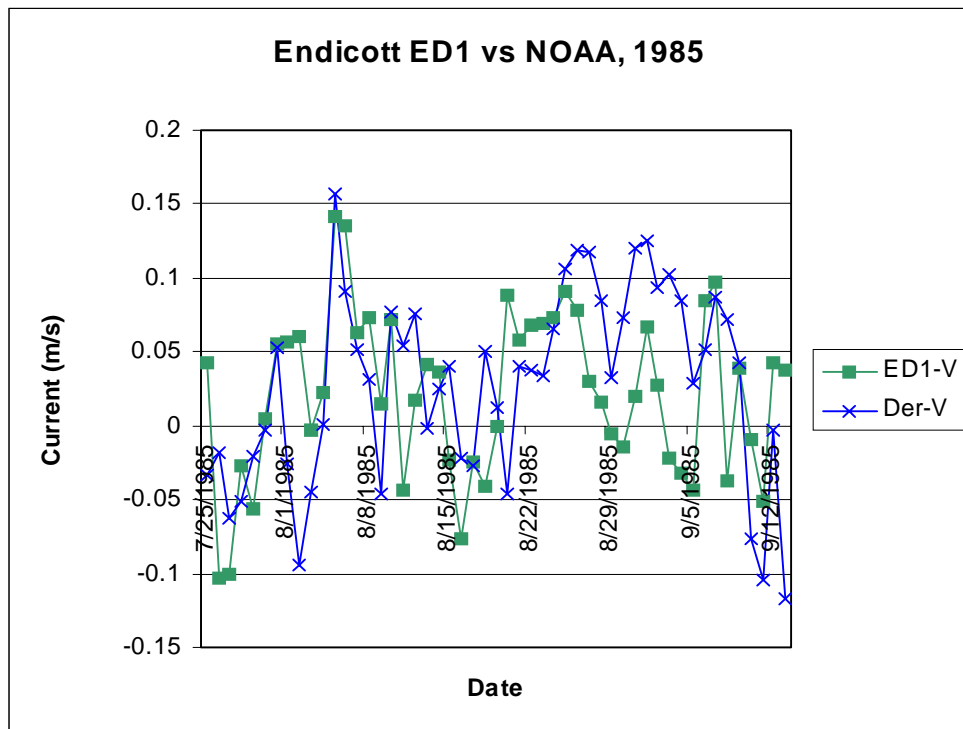
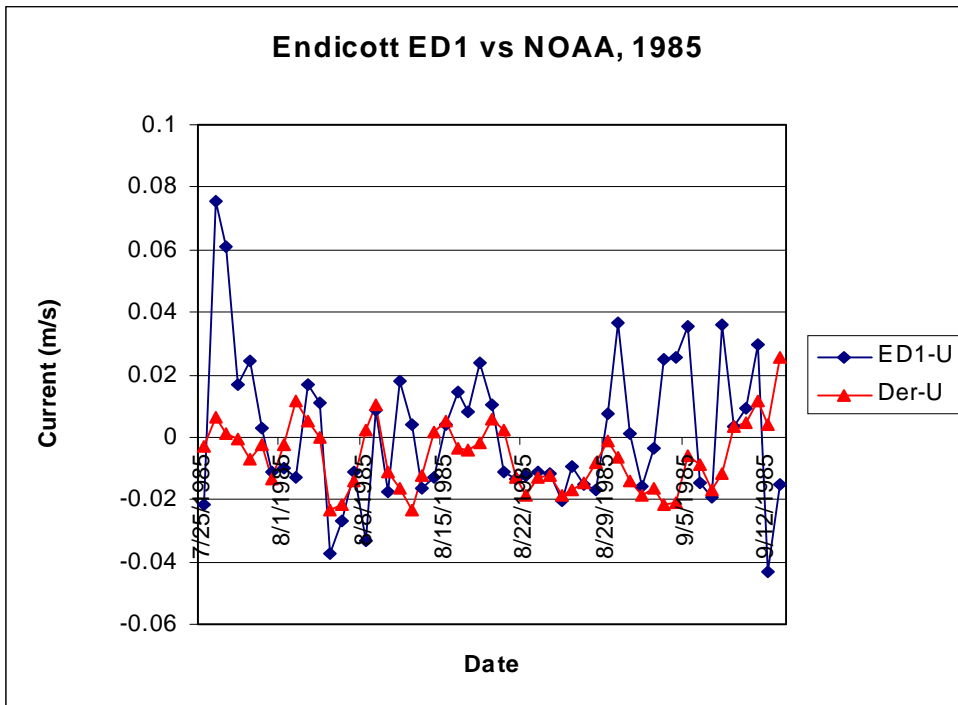
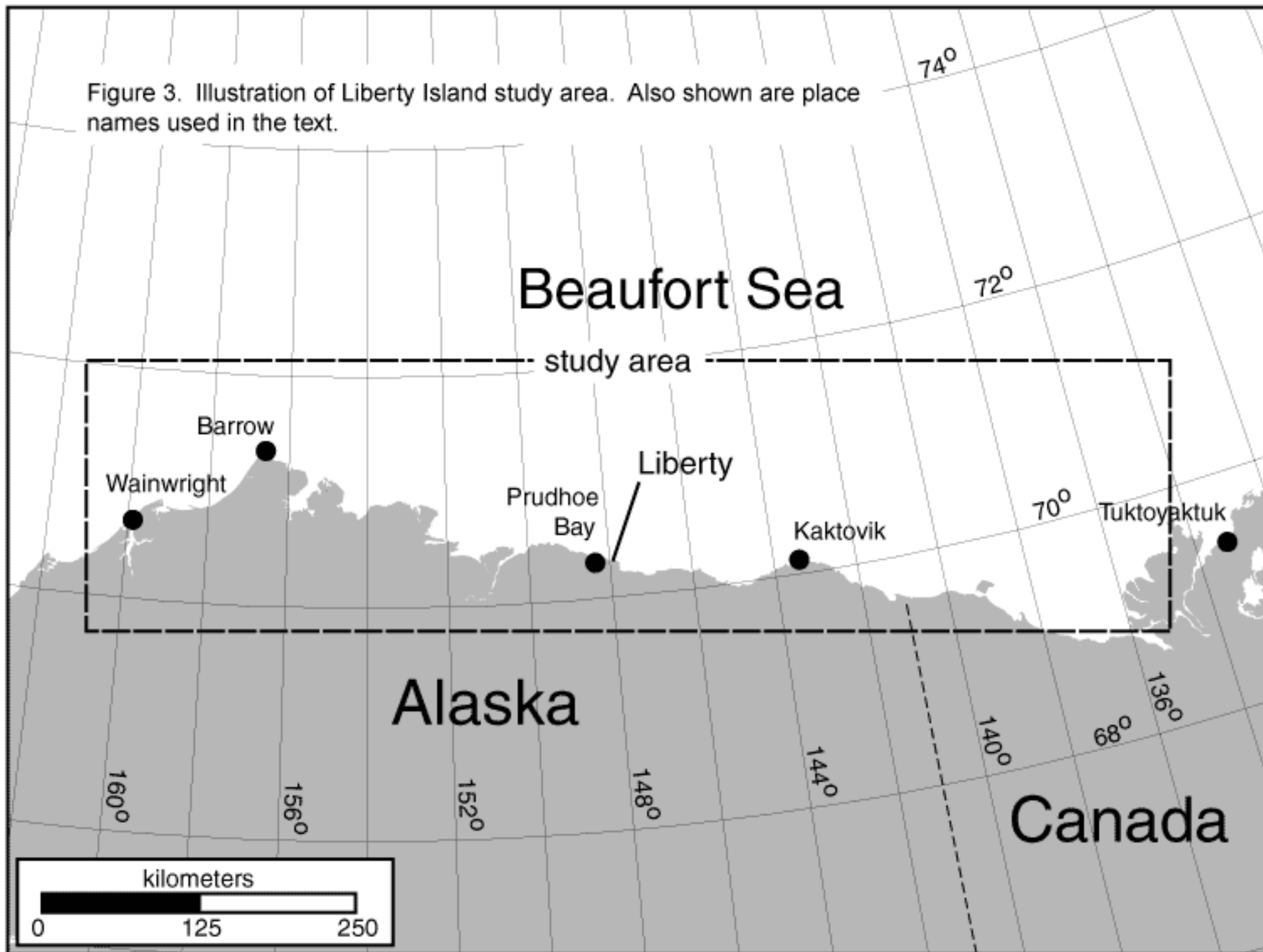

Figure 2. Example time series from 1985 shows the current flow at Endicott Station ED1 from the U (east-west) and V (north-south) components, plotted on the same axis with the current derived from the NOAA model for U and V (Der-U and Der-V)

Figure 3. Illustration of Liberty Island study area. Also shown are place names used in the text.



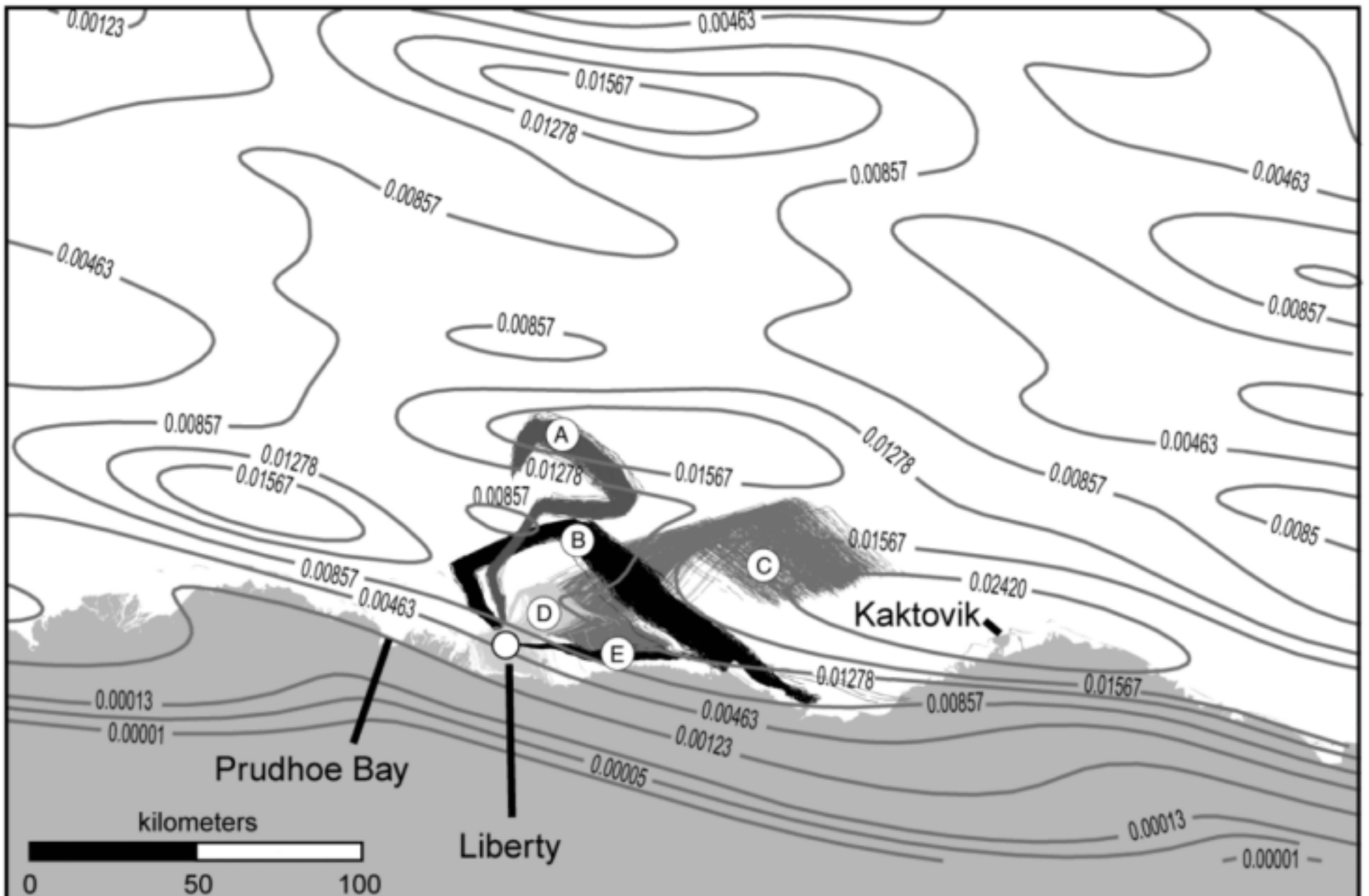

Figure 5. Polar bear density contours (bears/km²) and example, trajectories 22 August - 30 September. Trajectory id number (bears oiled): A. 3675 (7); B. 4451 (11); C. 4447 (24); D. 4161 (3); E. 4277 (1).

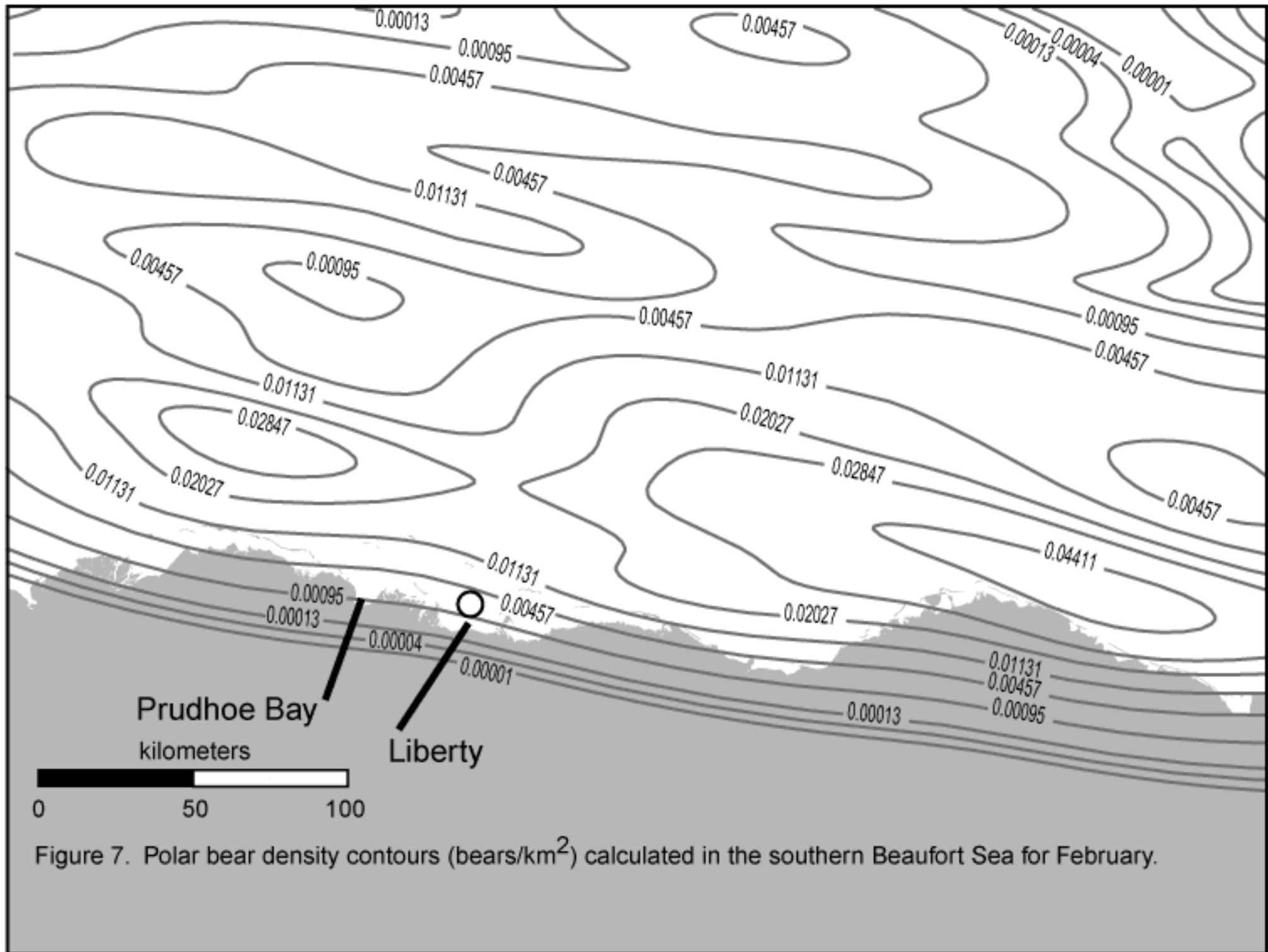

Figure 7. Polar bear density contours (bears/km²) calculated in the southern Beaufort Sea for February.

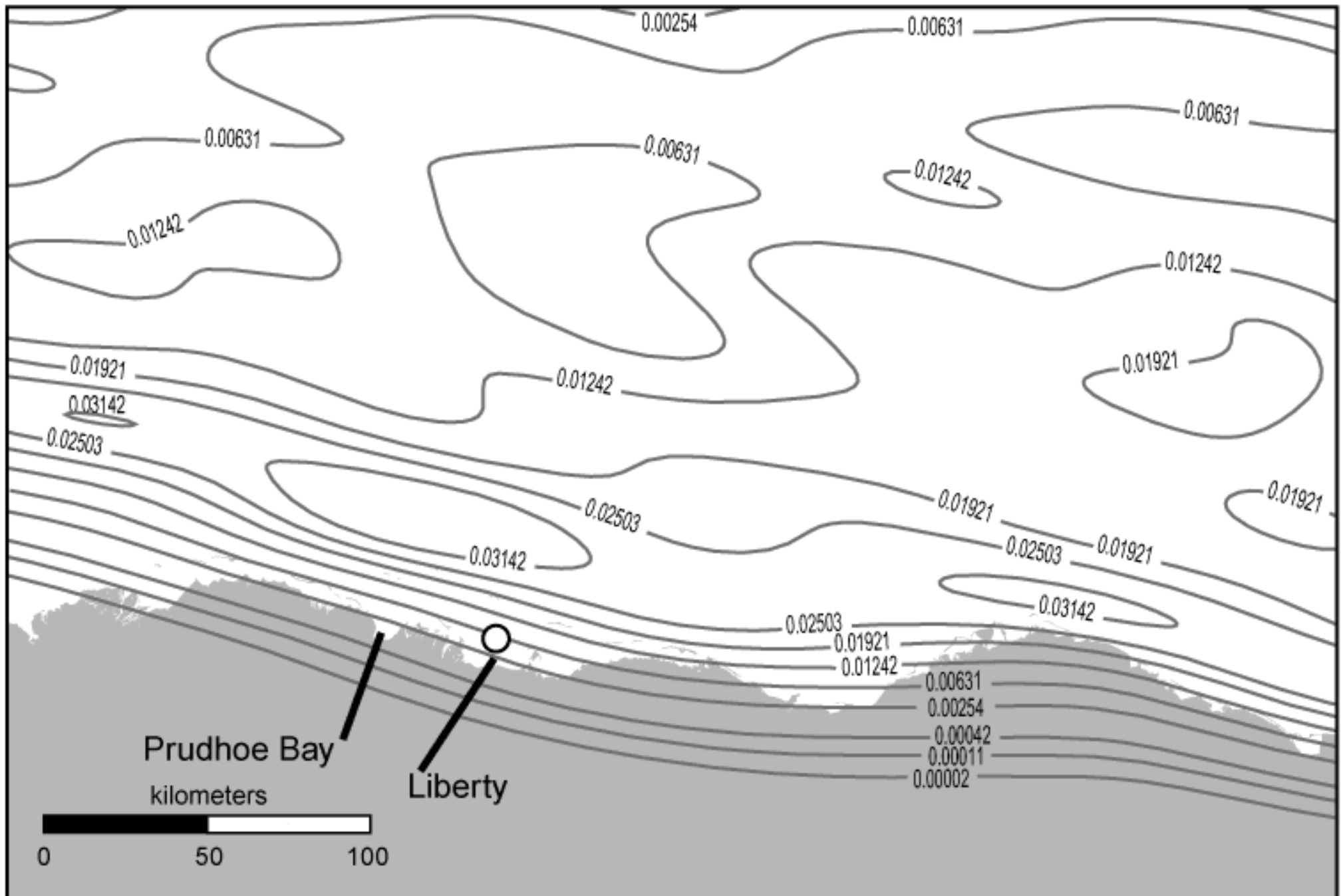

Figure 8. Polar bear density contours (bears/km²) calculated in the southern Beaufort Sea for June

Figure 9. Areas contacted by oil spills during the month of September. Shown here is the frequency histogram resulting from 500 simulated spills (trajectories) of 5912 barrels of crude oil. September conditions were predominated by open water and low coverage of sea ice.

September Oil-spill Trajectories:50m Spillets-Area Oiled (Square KM)

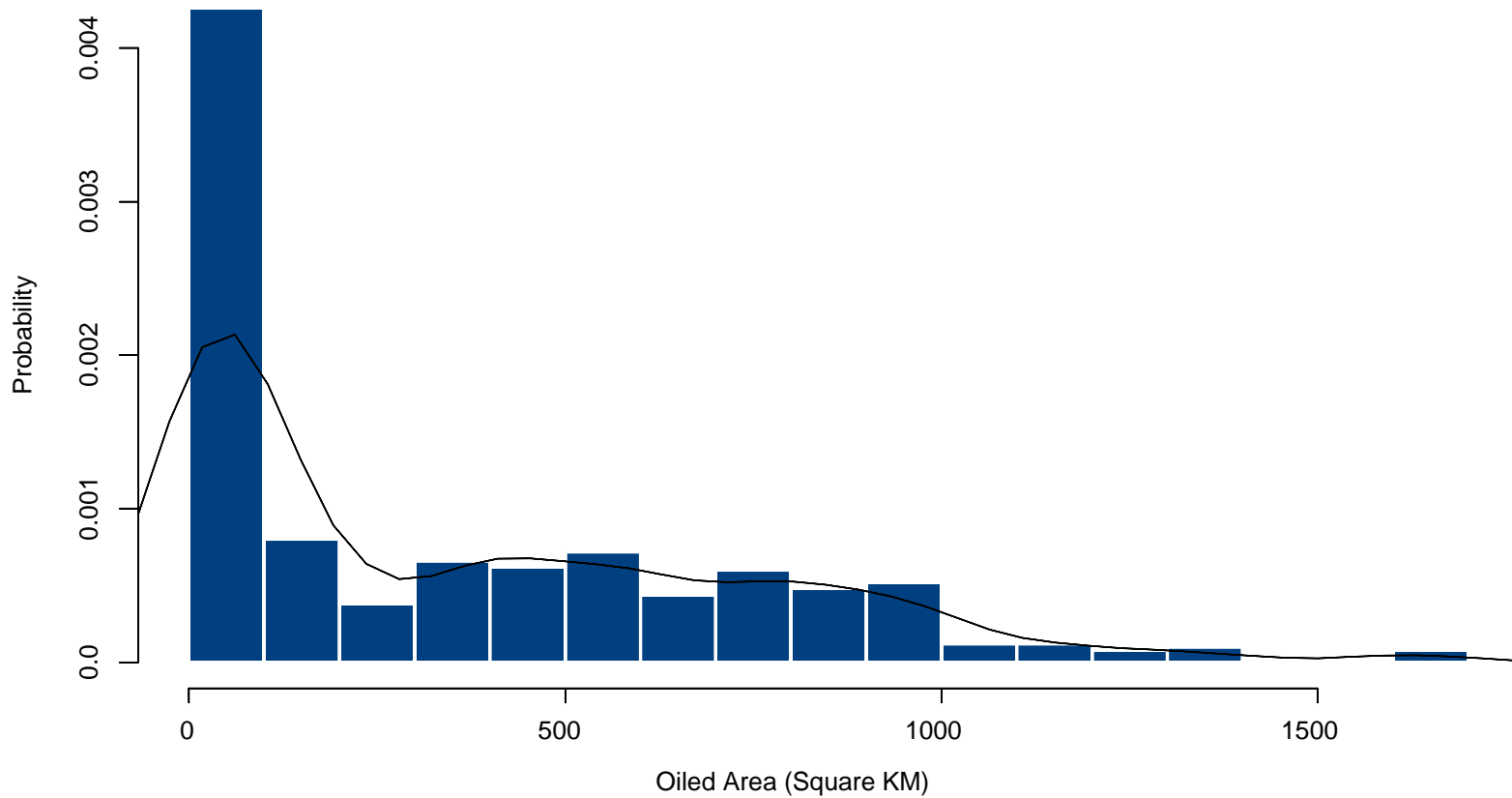

Figure 10. Numbers of bears estimated to be oiled by oil spills during the month of September. Shown here is the frequency histogram resulting from 500 simulated spills (trajectories) of 5912 barrels of crude oil. September conditions were predominated by open water and low coverage of sea ice.

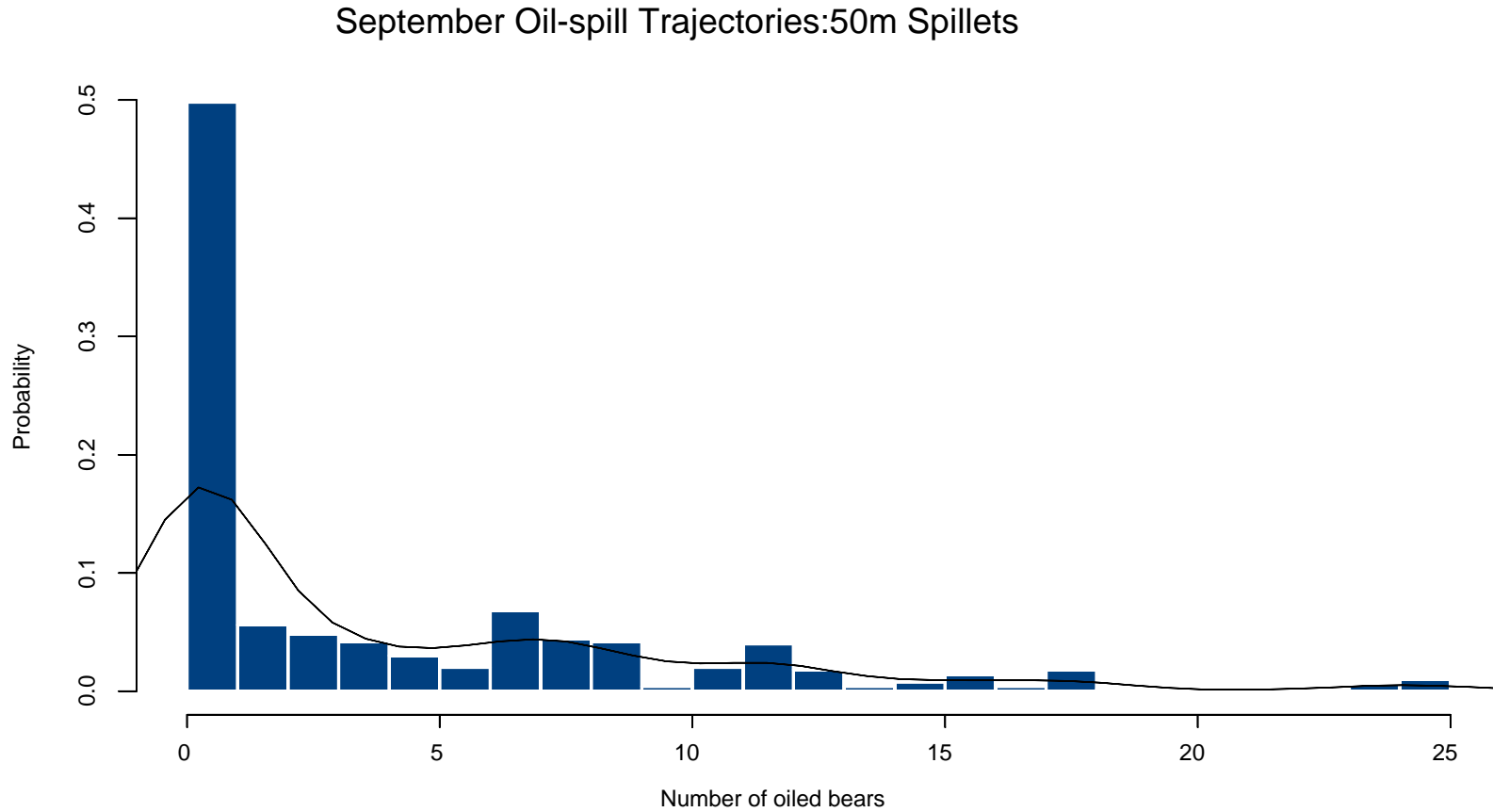

Figure 11. Areas contacted by oil spills during the month of September. Shown here is the frequency histogram resulting from 500 simulated spills (trajectories) of 2956 barrels of crude oil. September conditions were predominated by open water and low coverage of sea ice.

September Oil-spill Trajectories:25m Spilllets-Area Oiled (Square KM)

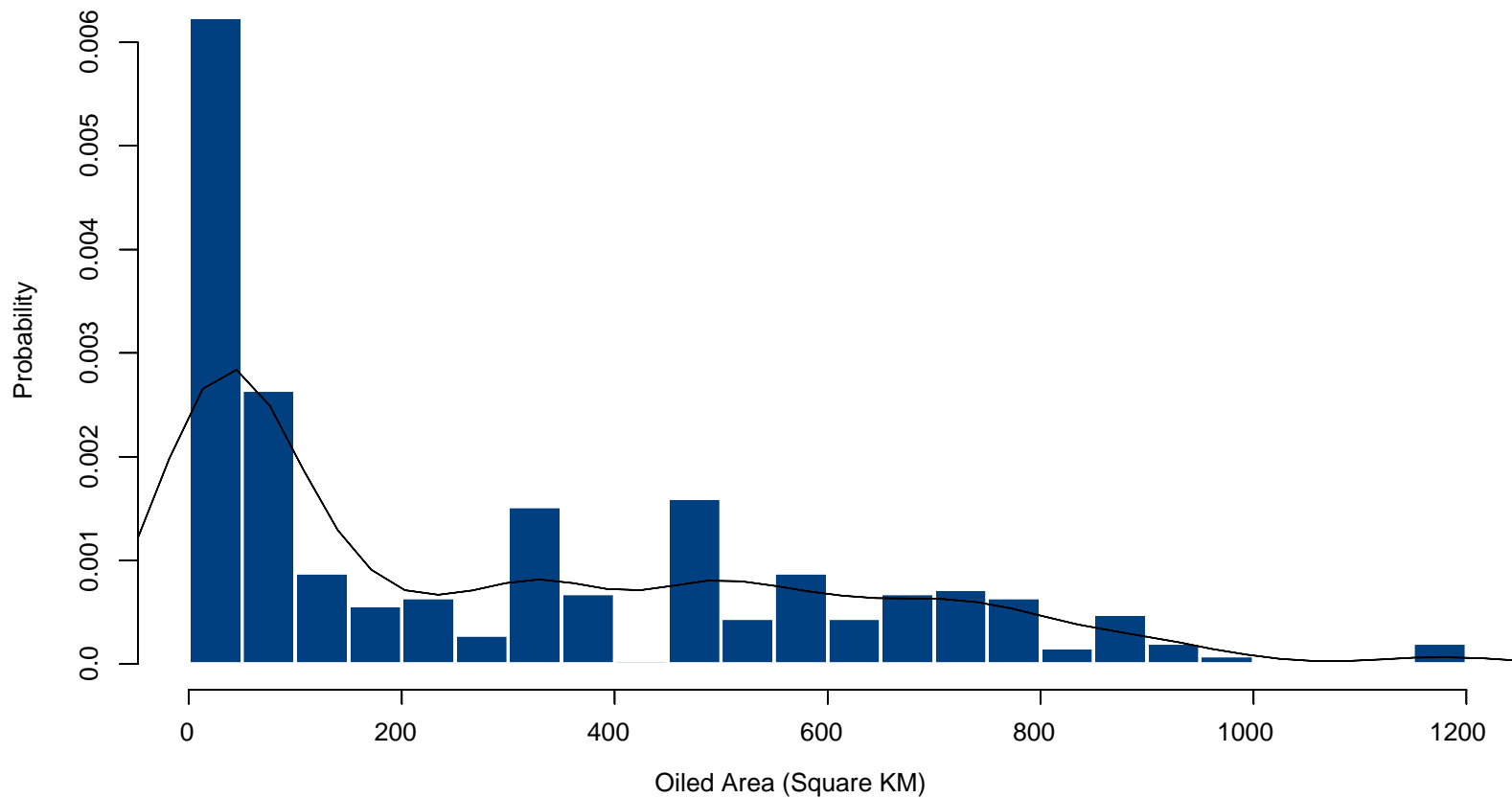

Figure 12. Numbers of bears estimated to be oiled by oil spills during the month of September. Shown here is the frequency histogram resulting from 500 simulated spills (trajectories) of 2956 barrels of crude oil. September conditions were predominated by open water and low coverage of sea ice.

September Oil-spill Trajectories:25m Spillets

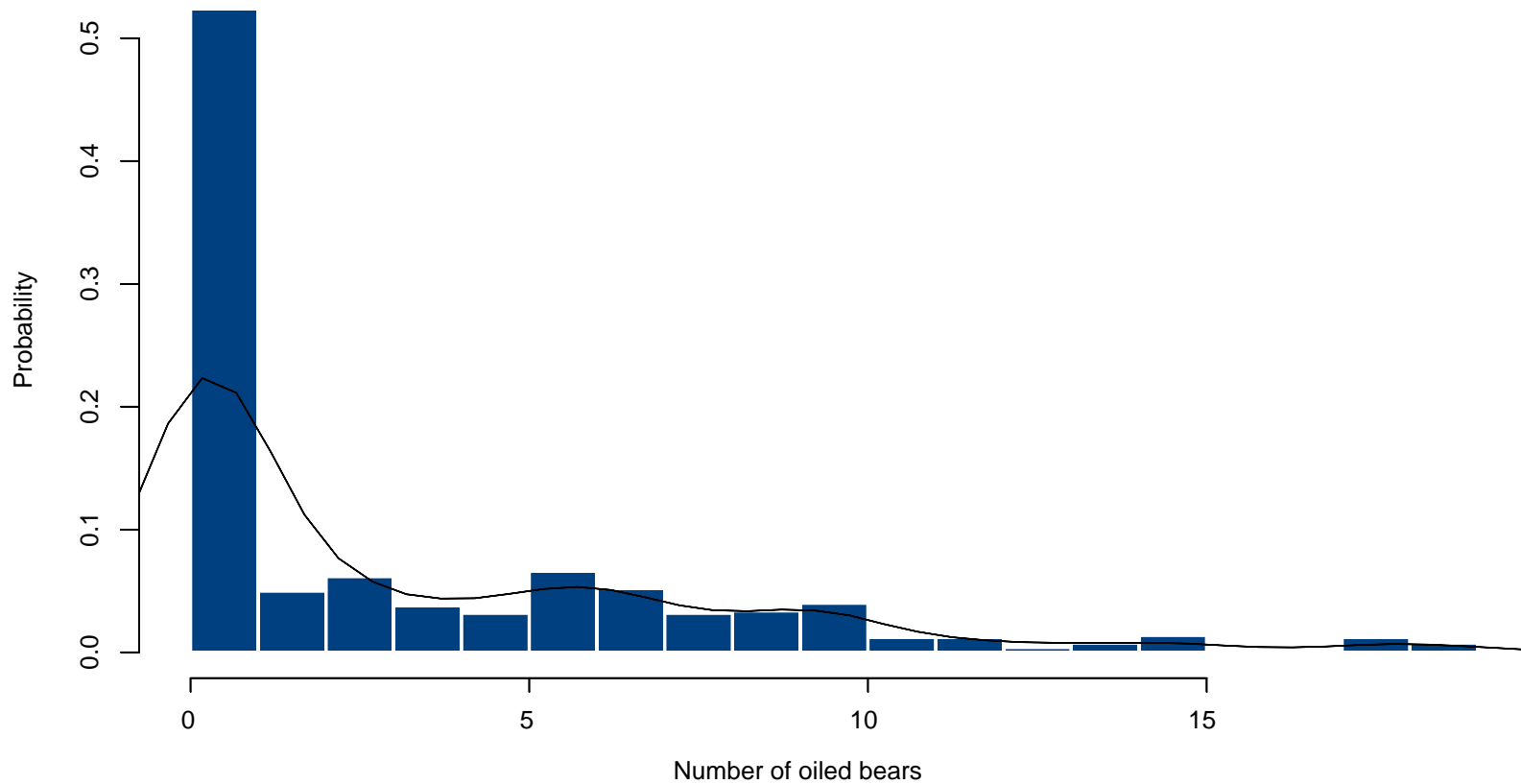

Figure 13. Areas contacted by oil spills during the month of October. Shown here is the frequency histogram resulting from 495 simulated spills (trajectories) of 5912 barrels of crude oil. October conditions were predominated by open and refreezing sea-water and mixed new and older ice.

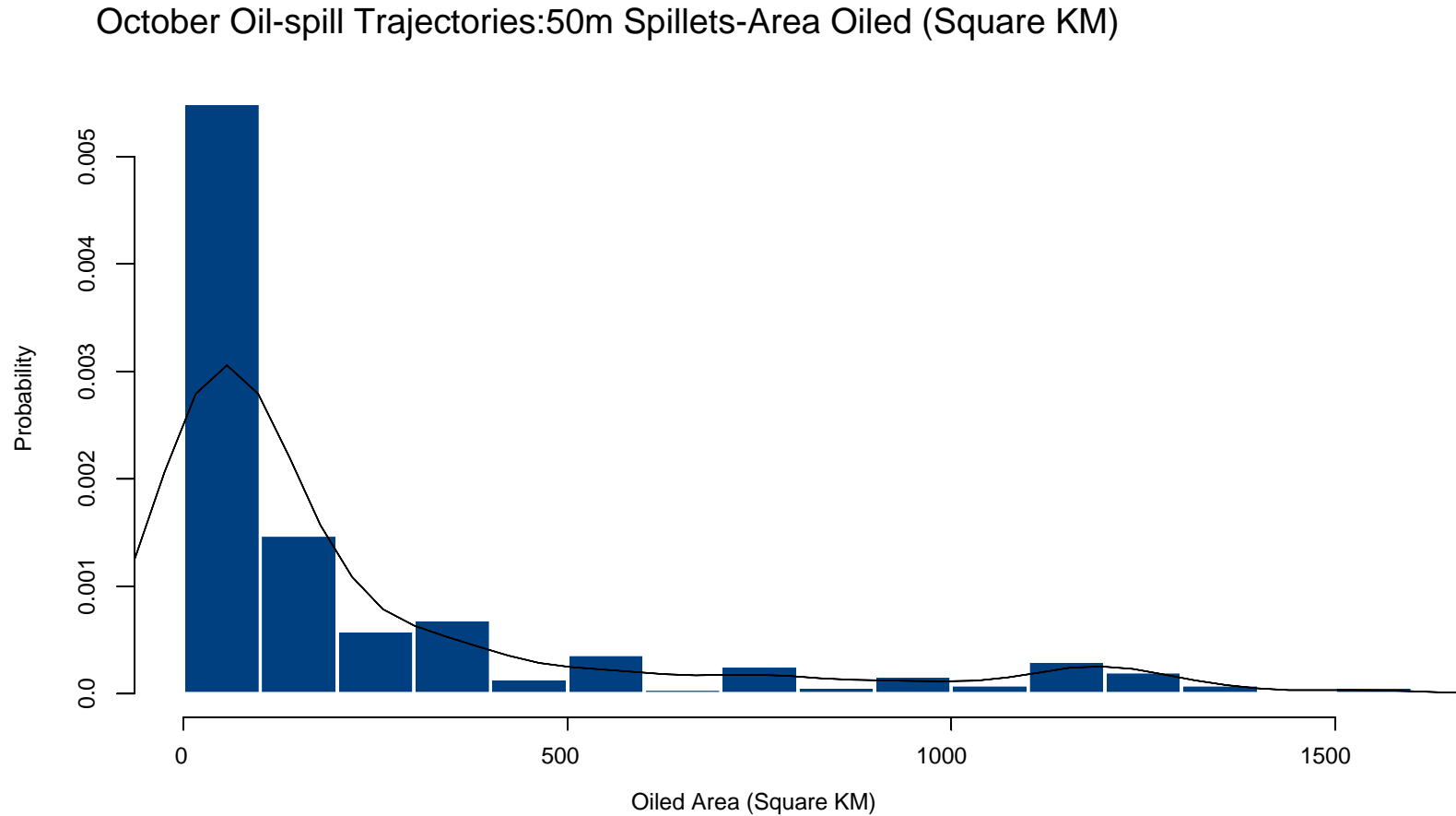

Figure 14. Numbers of bears estimated to be oiled by oil spills during the month of October. Shown here is the frequency histogram resulting from 495 simulated spills (trajectories) of 5912 barrels of crude oil. October conditions were predominated by open and refreezing sea-water and mixed new and older ice.

October Oil-spill Trajectories:50m Spilllets

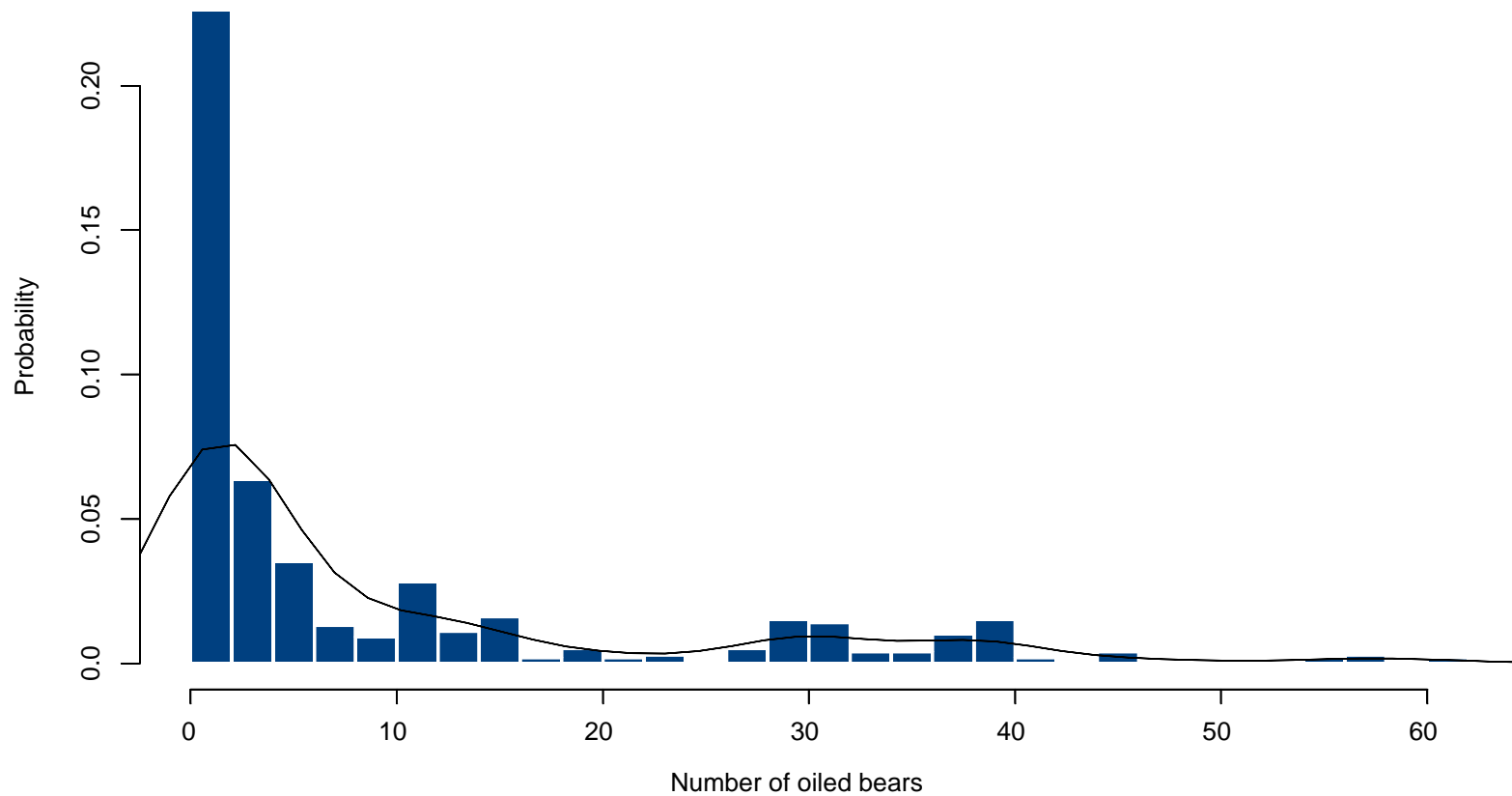

Figure 15. Areas contacted by oil spills during the month of October. Shown here is the frequency histogram resulting from 495 simulated spills (trajectories) of 2956 barrels of crude oil. October conditions were predominated by open and refreezing sea-water and mixed new and older ice.

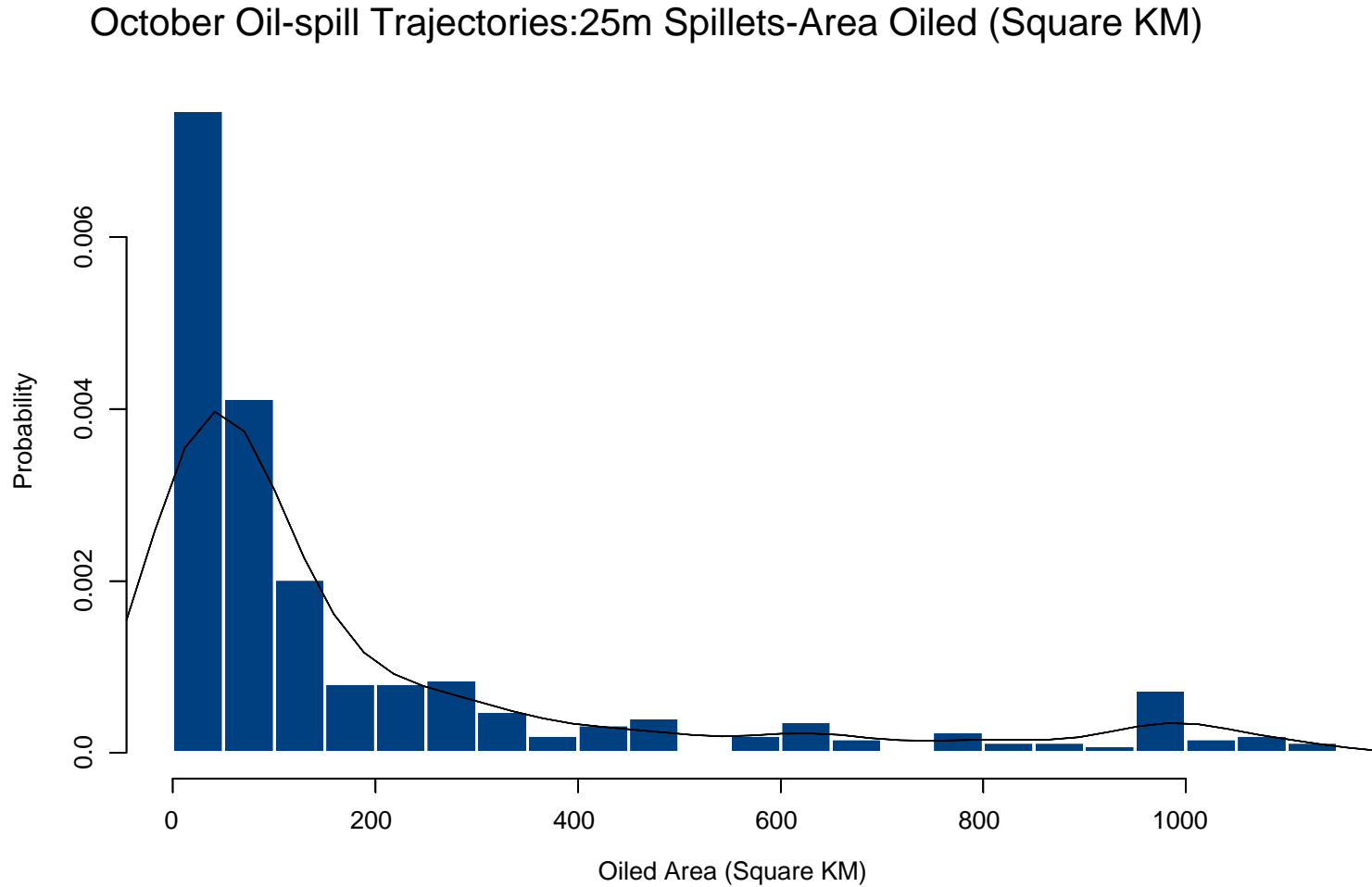
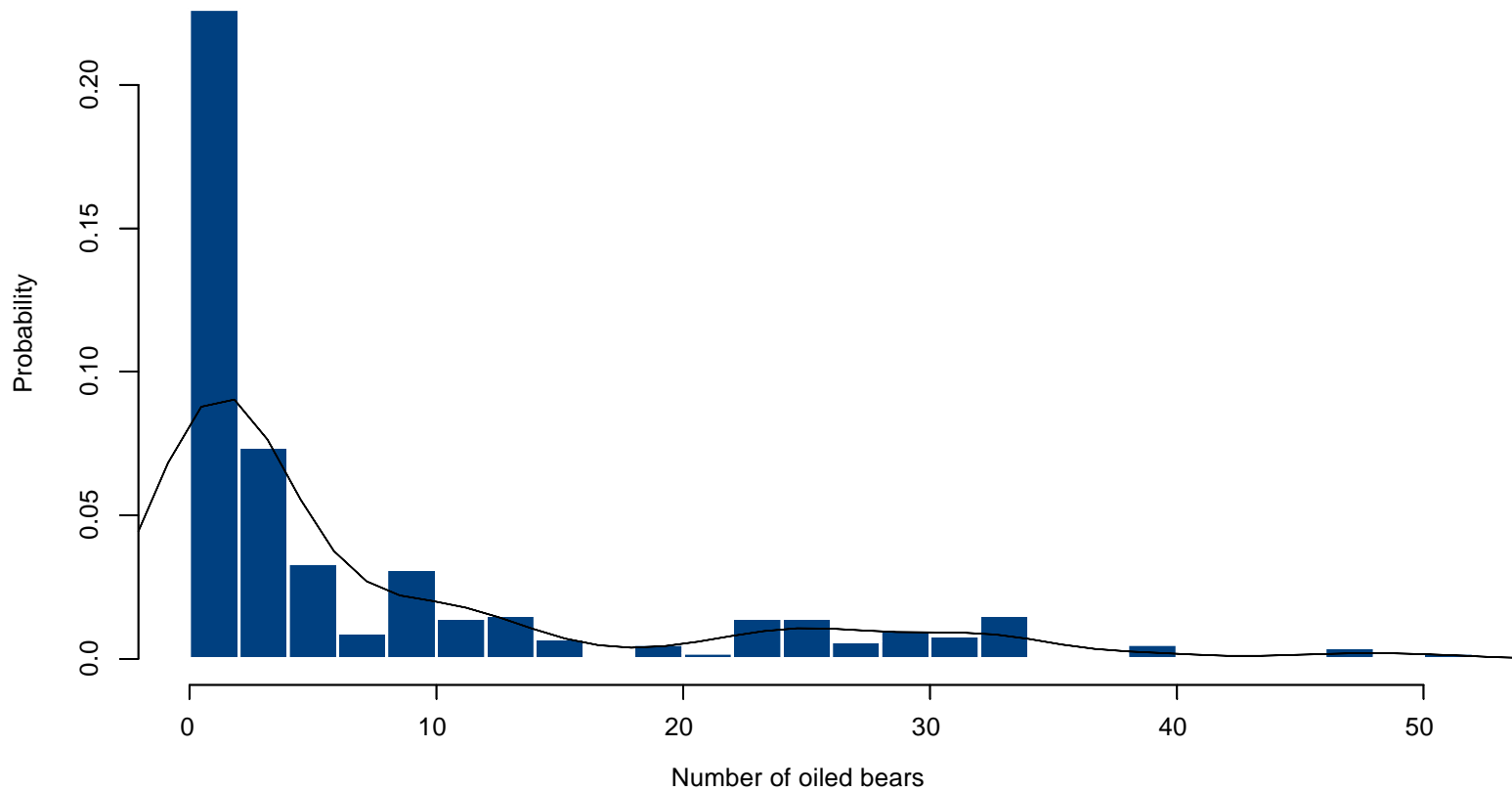

Figure 16. Numbers of bears estimated to be oiled by oil spills during the month of October. Shown here is the frequency histogram resulting from 495 simulated spills (trajectories) of 2956 barrels of crude oil. October conditions were predominated by open and refreezing sea-water and mixed new and older ice.

October Oil-spill Trajectories:25m Spillets



Exposure of Birds to Assumed Oil Spills at the Liberty Project, Final Report

This appendix was published as part of the Liberty Development and Production Plan (DPP) Draft Environmental Impact Statement (EIS) and was not revised for the Final EIS. The reader is referred to this appendix in the Draft EIS. This appendix is also available on the CD-ROM (MMS 2002-019 CD) and on the Internet (<http://www.mms.gov/alaska/cproject/liberty>).

Exposure of birds to assumed oil spills at the Liberty Project

Robert Stehn and Robert Platte,
U.S. Fish & Wildlife Service, Migratory Bird Management, Anchorage

19 September 2000

EXECUTIVE SUMMARY

Environmental impact statements require prediction of possible harm to wildlife populations that may result from a development project. Before this report, predicting the potential impact of an offshore oil spill to migratory birds in the Beaufort Sea was limited by insufficient information on the likely movement patterns of oil, and by the lack of data on the distribution of avian resources. For this report, the Minerals Management Service and the U.S. Fish and Wildlife Service Migratory Bird Management Division cooperated to develop quantitative methods to more accurately estimate potential effects of an assumed offshore oil spill from the proposed Liberty Project in the nearshore Beaufort Sea. The goals of this assessment were to estimate the number of sea ducks, loons, and gulls exposed to oil, the proportion of the total populations affected, the expected variability among spills, and the daily rate of bird exposure.

We determined bird distribution and abundance in a 15,174 km² study area based on observations during 6 systematic aerial surveys flown in late June, July, and August, 1999 and 2000. Simulated oil spill trajectories for July and August were obtained from Minerals Management Service. We used a geographic information system (GIS) to construct a spatial model to overlay the bird density estimates with the predicted trajectories for spill volumes of approximately 5,912 barrels (bbl) and 1,580 bbl. Numbers of birds exposed to oil each day of each spill were determined for long-tailed ducks (*Clangula hyemalis*), glaucous gulls (*Larus hyperboreus*), king eider (*Somateria spectabilis*), common eider (*Somateria mollissima nigra*), spectacled eider (*Somateria fischeri*), Pacific loons (*Gavia pacifica*), red-throated loons (*Gavia stellata*), yellow-billed loons (*Gavia adamsii*) and scoters (*Melanitta* spp.).

Long-tailed ducks (oldsquaw) were the most numerous species averaging 21,000 total birds in July and 37,800 birds in August. King eider averaged 4,600 and 6,700 birds during these months, while scoter species averaged 4,800 and 3,500 birds. Common eider and glaucous gulls were next most abundant. The spectacled eider population estimate averaged 540 birds in July and 30 birds in August.

The July spills differed from August spills in average duration and amount of new area oiled per day. The median July spill lasted 8 days compared to 4 days for the median August spill. August spills moved faster, covered more area, but did not last as long as July spills in part because some oil moved beyond the bird study area.

The average number of birds exposed to oil was greatest for long-tailed ducks with 1,443 and 2,062 birds affected by 5,912 bbl spills modeled for July and August conditions, respectively. Similarly, the average of all 1,580 bbl spills exposed 1,130 long-tailed ducks to oil in July and 1,710 in August. Bird numbers and oil spill trajectories were both highly variable and the combination caused extreme variability in avian exposure estimates. For example, between 4 and 7,744 long-tailed ducks were estimated to have been exposed to oil from a 5,912 bbl spill in July based on the lower and upper 90% confidence limits of bird numbers at the 10th and 90th quantiles among the 500 oil trajectories.

Based on the average of 500 spills of each size during July and August, the average proportions of the total populations exposed to oil were between 3% and 9% for long-tailed ducks, glaucous gulls, and common eider. The upper 10% of the 5,912 bbl spills caused greater than 17%, 18%, and 13% exposure to long-tailed ducks, glaucous gulls, and common eider populations respectively during July, and 19%, 13%, and 38% exposure to these species during August. King eider, spectacled eider, and scoters were least likely to have a high proportion of their populations

exposed to oil because of their widespread distribution or tendency to occur farther from the spill source.

Exposure to oil averaging the 5,912 bbl spill trajectories resulted in 2,234 individuals of nine species exposed to oil during July and 2,300 individuals in August. The average numbers exposed averaging all 1,580 bbl spills were 1,732 and 1,908 birds during July and August, respectively. Therefore, a 73% decrease in oil volume resulted in a decline of 23% or less in the number of birds exposed to oil.

INTRODUCTION

Birds that swim, roost, or feed in water contaminated by oil often die from hypothermia unable to maintain needed insulation and buoyancy normally provided by their water-repellent plumage. The toxicity of oil ingested with their food may kill other birds. Nevertheless, due to positive population growth rates and natural compensatory mechanisms, many populations can recover following a one-time mortality event (e.g., a localized oil spill) if the fraction of the total population killed remains small. As the fraction killed becomes higher, the severity of population impact can increase above that expected by a simple proportional change. Disruption of social behavior, loss of mates, competition with other species, or increased predation, may prevent or extend the time before population recovery. Declining populations or populations with a limited capacity for growth would be at greater risk. Many of the species that could be exposed to oil spilled in the Beaufort Sea are of this type. All loons, eiders, and other seabirds have a relatively low capacity for population growth. Long-tailed ducks, scoters, and all species of eider and loons are declining in at least some portions of their ranges in Alaska or Canada (USFWS 1999, Conant et al. 2000). Some species of birds from North Slope nesting populations and from populations nesting further east in Canada use the coastal waters of the central Beaufort Sea for feeding, resting, and molting.

Aerial surveys monitoring nesting populations on the North Slope of Alaska showed that most waterfowl populations have been relatively stable since 1986 or 1992 when these surveys began (Larned et al. 1999, Mallek and King 2000). However, red-throated loons have declined in the early June survey and long-tailed ducks have declined in the later June survey. The magnitude of these trends differ somewhat between the surveys apparently due to differences in timing, geographic extent, or sampling error. The U.S. Fish and Wildlife Service remains concerned and continues to carefully monitor these populations.

The U.S. Fish and Wildlife Service (FWS), Migratory Bird Management Division collaborated with the Minerals Management Service (MMS) to assess the impact on waterfowl and other birds of a assumed oil spill from the Liberty project in nearshore waters of the central Beaufort Sea. Using Geographic Information System (GIS) analysis programs, FWS integrated avian aerial survey data with oil spill trajectory data (MMS 2000) to estimate potential avian exposure to oil.

METHODS

Oil model

We received the oil spill trajectory data from MMS in Arcview shapefile format. We used simulated spills from July and August because we had sufficient bird data only for those months. Although many birds migrate through the central Beaufort Sea in June and September, no standardized survey data were available for these times. The model data included 500 trajectories for July and 500 for August. Each trajectory was composed of 500 spilletes. We converted the trajectories to ARC/INFO arc coverages with the SHAPEARC command. Because of the extreme degree of overlap of many of the arcs especially near the point of origin, some arcs were lost due to limits of “fuzzy” tolerance even with double precision options. For example, the July-2-ic shapefile of 100 oil spill trajectories had 8,279,463 arc shape records that converted to 8,229,464 arc segments with 49,999 missing, 0.6% of the arcs. These lost arcs had no effect on the outcome of the model as they only

represented redundant exposure to oil. Nevertheless, had we selected a more complex quantitative or probability-based interpretation of the trajectory model in which multiple or continued exposures to oil at the same location could be assessed, the loss of some spillite arcs could be of significant concern. Each coverage was then projected from longitude and latitude decimal degrees to UTM Zone 6. All arcs from each trajectory were reselected to 1000 separate ARC coverages.

We chose to analyze the potential impacts of two different spill volumes. Each arc in a trajectory represented the simulated movement in a 1-hour period of one spillite of oil defined approximately as either a 12 bbl ($1/500^{\text{th}} \times 5,912$ bbl) or 3 bbl ($1/500^{\text{th}} \times 1,580$ bbl) spill. Each spillite arc was influenced by a wind force vector common to the entire spill for that day, by a location-specific current vector, and by a random dispersal force vector each hour to simulate turbulence and spreading of the oil. Seventeen years of daily wind speed and direction data were available. The sequence of wind conditions for each spill trajectory was selected to start on a different day from the 527 possible days (17 years \times 31 days) for each month. The year and Julian day items in the INFO table indicated the conditions selected, however, we did not tabulate the frequency of these data. We interpreted the resulting set of 500 trajectories as a representative sample drawn systematically from all the equally possible sequences of wind that could occur for any given spill. We calculated the number of days since spill initiation based on the last four digits of the arc ID item, hours 1 through 721 (24 hours \times 31 days) since the start of the spill. The combined network of all 500 spillite paths defined the spatial pattern of each modeled trajectory.

The total size and duration of trajectories differed greatly. For example, trajectory 3106 had 3,499 arcs with a maximum duration of 7 hours, while trajectory 3183 had 358,989 arcs lasting all 30 days. The theoretically largest possible spill contained 360,000 arcs from 500 spillites \times 24 hours \times 30 days. Movement ended when a spillite ran into mainland shoreline, but the spillite path did not end upon encountering barrier islands. For our tabulation of number of birds and area exposed to oil, a trajectory was also considered to end when it moved entirely beyond the area for which we had bird density information. Many trajectories moved partially out of the bird survey area.

We chose to convert the oil trajectory data to a raster or grid cell format for more efficient analysis in the GIS spatial overlay model. Each spill trajectory ARC coverage was converted from vector to raster format using the GRID module LINEGRID command (Fig. 1). Thus, a spill previously represented by a set of 500 lines was now represented as a grid of square cells with a surface area that represented the geographic “footprint” of the spill. An alternative would have been to buffer the arcs by a distance equal to the radius of a spillite to produce an oiled polygon, however due to the large number and complexity of arcs, it was not possible. We used a grid cell size of 50x50 meters to represent the larger spill volume of 5,912 bbl and a grid cell size of a 25x25 meters to represent a 1,580-barrel spill. The grid cell size that would most closely match the actual estimated area of oil after conversion to a grid coverage would have been 42.2m ($= (2(2)^{0.5})/\pi$) or 0.9003 times 46.85m) and 24.3m (0.9003 times 27.04m) using calculated radial spill diameters (Table 8, MMS 2000). The 50x50m and 25x25m cell sizes were considered reasonable approximations.

We assigned each grid cell a data value equal to the number of days (1 to 31) after initiation of the trajectory when a spillite first entered that cell. If a cell contained spillites from more than one day, a weight table was used to give priority for the value of that cell to the earliest day. Trajectories (≈ 70 of 500) too complex to be converted by the LINEGRID command were converted to individual day coverages, then to grids for each day, and finally merged into a complete trajectory grid. The trajectories, originally modeled as a connected series of arcs representing movement during 720 hours, were now modeled as oiled grid cells each coded by day on which it was first oiled. All other cells were considered unoiled and coded as “No Data” to be excluded from the analysis. Several trajectories had one or more spillites with data extending to day 31. The day 31 spillites of these trajectories were not included in the analysis.

Aerial surveys for waterbirds

Several different aerial survey data sets have been collected in the central Alaskan Beaufort Sea, however, data were not equally useful for spatial overlay analysis. LGL Limited (Steve Johnson, Lynn Noel) provided avian data from repeated aerial survey transects for 2 areas (termed “industrial” and “control”) located on either side of the Liberty project during 1977-1984, 1989-1991 (Johnson and Gazey 1992), and 1998-1999 (Noel 1999) (Fig. 2). The objective for the LGL survey was to detect change in bird numbers over time between the two areas. The data from these surveys were not readily useable in a GIS. Locational accuracy of observations was at best within 1,260 m because data were recorded by 30-second intervals (30 sec x 42 m/sec average flight speed). Transects were not placed randomly or systematically across gradients of bird density or habitat. Any interpretation of spatial pattern of bird density from these data was almost entirely dependent on assumptions concerning delineation of the area that each transect “sample” represented. This held whether the bird density was interpolated by any of several methods between the sampled transects, or whether the observed transects were taken as a representative sample of the density in some larger delineated area. The LGL survey was not intended as a valid sample of the entire area; it was an indexing procedure. Therefore, we did not use these data for this analysis.

FWS flew six nearshore surveys intended to replicate the LGL design in July and August of 1999 and 2000 (Fig. 3). In 1999, FWS also conducted 3 offshore surveys consisting of 36 north-south transects evenly spaced at 5.4 kilometers and extending from the Kogru River to Mikkelsen Bay (Fig. 4). The objective of these offshore surveys was to verify the presence of spectacled eider near locations received from satellite transmitters implanted in eiders. In 2000, the same 36 transects plus seven additional transects were flown extending coverage east to Brownlow Point. The systematic offshore transects started at the coast and extended north across nearshore, mid-lagoon, and barrier island habitats. Fog conditions determined the northern extent of some of the late June and July survey transects. June and July offshore transects averaged 56 km long (range 14 - 76 km). The August offshore survey transects were less affected by fog conditions and averaged 60 km in length (range 22 - 70 km).

The available aerial survey data included:

1. nearshore index transect data, LGL, 1977-1984, 1989-1991 (Johnson and Gazey 1992),
2. nearshore index transect data, LGL, 1998-1999 (Noel 1999),
3. nearshore index transect data, FWS, 1999-2000,
4. offshore systematic survey transect data, FWS, 1999-2000.

Because the data from systematic designs provided unbiased population estimates and useful bird distribution data for spatial analysis, we used only the data from the June, July, and August 1999 and the June, July, and August 2000 offshore surveys for our analyses. Surveys flown between 24 June and 31 July were assumed to represent average July bird density, and those flown 1 August to 6 September represented August bird density. We estimated variance among the surveys by jackknife or standard methods to provide an appropriate estimate of variation in average bird density.

Details of aerial survey procedures, navigation to transect waypoints, flight speed, altitude, and data recording methods have been reported elsewhere (Butler et al. 1995a, 1995b). Instead of using the method of continuous tape recording and interpolation of positions based on time, observers used custom data-recording and transcription programs (J.I. Hodges, FWS, Juneau) on laptop computers to record observations with locations downloaded directly from the aircraft GPS. Dates and observers for the 6 aerial surveys used in this analysis were: 1) 28, 29, 30 June 1999 by observers TT and DM; 2) 27, 28, 30, 31 July 1999 – TT and RP; 3) 31 August, 2, 3 September 1999 – WL and JS; 4) 24, 25, 26, 27 June 2000 – JF and AB; 5) 25, 26, 28 July 2000 – JF and DM; and 6) 25, 26, 27, 30 August 2000 – JF and DM.

Aerial survey data consisted of the location, avian species, and group size for each observation. The observed sample transect area was a 400 meter-wide strip centered along the aerial

transect flight path flown and recorded by GPS coordinates which were downloaded every 5 seconds to a data file.

Stratification of the survey area

We expanded the bird densities observed along narrow strip transects to the area within each stratum. If no other information were available, or if both the habitat and bird density were relatively homogeneous, various mathematical methods could interpolate a smoothed density surface from a series of sample points. However, the bird densities determined along the curved nearshore survey transects were not random or systematic within the entire area. For example, descriptions and maps available from previous observers characterized high concentrations of molting long-tailed ducks in specific habitats (e.g., along the leeward side of barrier islands). We chose to divide the study area into strata based on a combination of habitat-based features following those defined by Johnson and Gazey (1992). Delineation of stratum boundaries was somewhat arbitrary and not without error; but it was more accurate than simple numerical smoothing methods that would ignore previous biological observations and descriptions. We then calculated bird density using standardized methods assuming that the flightlines were a representative sample within each stratum. Although bird population estimates could be derived from the offshore aerial surveys without stratification, or with fewer strata, a single stratified design was selected to allow comparisons among all surveys when additional data are incorporated into the analysis.

We divided the study area into strata based on the location of the aerial survey nearshore index transects and geographical features such as proximity to the coast, major river deltas, barrier islands, and water depth. The coastline was buffered to create a 400-meter-wide strip from Brownlow Point to the Kogru River. The width of this strip was then expanded where necessary to include the shoreline aerial survey transects which sometimes crossed bays at greater than 200 meters from the coast. The shoreline strip was subdivided into geographic sections from the Kogru River to the west side of the Colville Delta, around the Colville River Delta, from the Colville Delta to near Oliktok Point, from Oliktok Point to the east side of Prudhoe Bay (Sagavanirktok Delta), from Prudhoe Bay to east of Foggy Island Bay, the finally from there to Brownlow Point.

Barrier islands were also buffered to create a 400-meter-wide strip along their inshore (lagoon) sides. We then expanded this strip in some areas to include the locations of the nearshore aerial survey transects designed to sample this habitat. We used actual flight paths flown by FWS during 1999 nearshore surveys to help modify the strata boundaries. The open water gaps between barrier islands defined a "pass" habitat stratum of variable width, depending again on the aerial survey transects locations. We subdivided the barrier islands and the pass habitat into four similarly defined geographic regions: eastern, central, industrial, and western.

We defined the remaining water area between the shoreline strips and the barrier islands or pass habitat as a mid-lagoon stratum. It was subdivided into geographic regions as follows: Brownlow Pt. to Tigvariak Island, Tigvariak I. to the west side of Prudhoe Bay, west of Prudhoe Bay to Oliktok Point, and Oliktok Point to the western edge of the survey area. With only two small areas of barrier islands in the western area, the mid-lagoon, pass, and inshore marine strata were combined in this region and called the western shallow marine stratum.

North of the barrier islands, we used the 8-meter bathymetric contour line to roughly define inshore marine strata that were divided into 3 geographic areas matching the subdivisions for the mid-lagoon strata. The deeper water to the north of the 8-meter bathymetric line to the northern extent of the survey flightlines was partitioned into 3 offshore marine strata: east of the west side of Prudhoe Bay, central from west Prudhoe Bay to about mid-Colville River Delta, and west to the western boundary.

Delineations resulted in 50 polygons classified into 22 strata (Fig. 5) within the 15,174-km² study area. Barrier islands were included either within the 400-meter-wide buffer south of the barrier islands or within the nearshore marine water to the north. Some of the spill trajectories moved to the north or east beyond the stratification area for which we estimated bird density (Fig. 6).

We estimated only the number of birds exposed to oil within the stratified bird density area. Consequently, the number of birds exposed to oil should be considered a minimum value as those spills leaving the surveyed area affect additional birds.

Bird density estimates

The intersection of the survey transects arc coverage with the stratification polygon coverage determined those sections of each transect within each stratum. The proportions of the total distance along each flight line (i.e., where the transect crossed in and out of a stratum polygon) were written to a stratification file. The bird observations and transect sections located between these two proportions of total distance were considered in that stratum. The number of birds of each species summed for all transects within a stratum, divided by the sum of observed area within that stratum, provided a ratio estimate for the mean bird density. For July, we combined four offshore surveys, flown beginning on 28 June 1999, 27 July 1999, 24 June 2000, and 25 July 2000, to estimate the mean bird density for each stratum. The length and number of transects differed among surveys due to fog conditions. The data were combined as weighted by the transect area observed. The variance of the mean was calculated with a jackknife estimate using the four survey means as weighted by area observed within each survey. However, with only two surveys flown in August, beginning 31 August 1999 and 25 August 2000, the variance was calculated simply from the difference between the two surveys. These variance estimates were compared to the ratio estimate variance formula using all the transect sections within each stratum. For each species and each stratum, we converted the estimated density of observed total birds per km² to number of birds in a 50x50 m grid cell by multiplying by 0.0025, and to birds in a 25x25m grid cell by multiplying by 0.000625. For example, spatial distribution of the average number of king eider per 50-meter cell for 22 strata is depicted in Fig. 7.

Confidence intervals were derived using the between survey variance estimates rather than the ratio-estimate variance. We calculated the upper and lower 90% confidence interval values for the bird density as the mean plus or minus 1.6448 times the square root of the variance of mean density. If the lower 90% confidence interval was smaller than the actual number of birds seen, the actual number of birds observed on transects divided by the total stratum area was used as the lower 90% limit.

The nine species analyzed for this report were long-tailed duck (*Clangula hyemalis*), glaucous gull (*Larus hyperboreus*), king eider (*Somateria spectabilis*), common eider (*Somateria mollissima nigra*), spectacled eider (*Somateria fischeri*), Pacific loon (*Gavia pacifica*), red-throated loon (*Gavia stellata*), yellow-billed loon (*Gavia adamsii*), and combined scoter species (*Melanitta* spp.). Other species observed (Table 1) included shorebirds, northern pintail, white-fronted geese, scaup, black brant, jaegers, arctic tern, Canada geese, snow geese, and seals.

Identification of scoters and eiders can be difficult at the far edge of transects, under poor visibility conditions, or with large flocks of mixed species. Combining all surveys, we recorded 1032 surf scoters (80% of those identified), 204 (16%) white-winged scoters, 46 black scoters (4%), and 542 unidentified scoters (Table 1). The total number of scoters exposed to oil was estimated without regard to species, and the result could be split by species using these fractions. Similarly, we recorded 5493 king eider (84% of those identified), 935 common eider (14%), 148 spectacled eider (2%), and 333 unidentified eider. Because of the threatened status of spectacled eider, we analyzed the three eider species separately and any unidentified eiders were not included in the estimated numbers exposed to oil. Therefore, if the assumptions hold that unidentified eider occur in the same proportions and with the same spatial distribution as those identified, the unidentified birds represented 279 king, 47 common, and 7 spectacled eider. The total number exposed to oil should therefore be adjusted up by a factor of 1.051 for each species, e.g. $1.051 = (5493 + 279) / 5493$ for king eider.

GIS overlay of oil spill trajectories with bird density

We converted the average bird densities from the July and August surveys to average bird numbers per grid cell in each of the 22 strata. We joined the mean, lower 90%, and upper 90% confidence interval of number per cell for nine species into an INFO file template. These INFO files were joined by the common item STRATA to the stratification grid attribute table using the ARC relate command. We used this one grid coverage to model the numbers for each bird species for spatial analysis rather than creating individual grids for each species.

To calculate the potential number of birds exposed to oil, we overlaid the bird density grid with each trajectory grid. For each of the 500 spill grids each month, the number of birds per oiled cell for all cells on each day of the spill was summed using the ZONALSUM grid function and rounded to the nearest integer after adding 0.5. This sum represented the number of birds exposed to oil for each day of each trajectory. We then used the COMBINE grid function to tally the frequency of cells with unique occurrences of day number and bird zonalsum number for each trajectory. For each trajectory, the process output an ASCII file with day, number of cells oiled, and sum of birds exposed to oil each day.

We repeated the overlay process for each of the 27 bird numbers per cell (9 species x 3 density levels representing the mean, lower 90% confidence interval and upper 90% confidence interval) for each of 500 oil spill trajectories in July and in August for both the 50 m and 25 m grid cell sizes. We performed 54,000 grid overlays (27 species measures x 500 trajectories x 2 months x 2 spill volumes) with each result written to a separate output file. From these files, the number of cells with oil and the number of birds exposed to oil each day were assembled into 500 trajectory x 31 day arrays for each species, month, and grid size. We copied these arrays into Excel spreadsheets for descriptive and graphical summarization. Output text files from the overlays were used to summarize both the surface area extent and duration of the July and August spills within the 15,174 km² of the bird survey area (Fig. 8).

RESULTS

Oil spills

Many July spills (n = 213, 43% of the total) lasted ≥ 3 days, but another 43% (n = 216) remained at least partially within the bird grid for ≥ 26 days (Fig. 8). The average extent of all 5,912 bbl spill trajectories during July equaled 376.7 km². Most July trajectories remained within the bird grid with only 9% (n = 43) having $\geq 10\%$ of their oiled area outside of the bird survey area. In July 370.4 km² (98%) of the oiled area remained within the bird density grid. A slightly greater number of August trajectories (n = 250, 50%) lasted ≤ 3 days, although only 18 trajectories (4%) remained within the bird grid for 26 or more days. Approximately 25% of the trajectories ended because they moved out beyond the extent of the bird grid. The average extent of all 5,912 bbl spills during August was 558.7 km² with only 265.3 km² (48%) of the total oiled area remaining in the bird grid. In August, 136 (27%) trajectories had $\geq 10\%$ of their oiled area outside of the bird survey area. Consequently, we underestimated the number of birds exposed to oil particularly during August. The degree of bias is not likely proportional to the oiled area beyond the bird-surveyed area because bird density probably differs and the distribution of oil movement north and east of the survey area is unknown.

Bird density

The most abundant species observed during July was long-tailed ducks with a total estimated population of 21,000 birds (Table 2). Highest densities of long-tailed ducks occurred in the shoreline-east, barrier-island-east, and nearshore-marine-east strata that indicated 39% of the average July population in $< 2\%$ of the total area. An additional 44% of the July long-tailed duck population occurred in other barrier-island, mid-lagoon, and shoreline strata. Coefficients of variation (CV) ranged from 0.55 to 1.05 indicating that population estimates for individual strata were imprecise. The CV for the total population estimate equaled 0.283. The coefficient of variation is a relative measure

of the variability of the mean density estimates for individual strata for comparison purposes. It can also be used for comparing densities between different times. During August, the estimated average long-tailed duck population equaled 37,800 with a CV of 0.344 (Table 3). Similar to July, a high proportion (52%) of the population occurred in the shoreline, barrier island and mid-lagoon strata at the east end of the area.

King eider was the second most abundant species (Table 2) averaging 19,800 birds. Most (91%) were seen in the three offshore strata in water >8m deep north of the barrier islands, with the highest average density of 3.6 birds per km² in western offshore-marine strata. By the end of August, king eider had declined to an average of 6,700 birds.

Scoters (species combined) were the third most abundant species with estimated July and August populations of 4,800 and 3,500 individuals, respectively (Tables 2, 3). The shallow-marine-west stratum north of the Colville River Delta and the three similar mid-lagoon strata contained 80% of the scoters in July and 92% in August. Common eider averaged 3,300 and 1,500 total birds, and glaucous gulls averaged 2,700 and 1,700 birds for July and August, respectively (Tables 2, 3). Common eider and glaucous gulls were observed in all habitats and geographic areas. In contrast, spectacled eider were seen only in the western or central offshore marine stratum, the same areas where king eider were abundant. The estimated population size for spectacled eider in the study area was 540 in July and 30 in August (Tables 2, 3).

Pacific loons were the most abundant of the three loon species totaling 764 birds in July. The red-throated loon population was estimated at 164 birds and yellow-billed loons at only 95 birds (Table 2). The three loon species were observed predominantly in mid-lagoon, shallow marine west, and nearshore marine habitats. We obtained very similar results in August with 666, 169, and 17 loons of these species (Table 3).

Variance in bird population numbers based on between survey differences was somewhat higher than variance calculated as a ratio estimate among all transects flown within each stratum. The ratio estimate measured the geographic variability within each stratum assuming all survey transects were independent random samples. The average CV across all nine species for July was 0.346 among surveys (Table 3) compared to 0.285 from ratio estimates among transects. For August, the average CV across all nine species was 0.533 among surveys (Table 3) compared to 0.488 from ratio estimates among transects. The approximate agreement of the two variance estimates adds some degree of reliability to the among survey variance estimates that were based on only 2 - 4 replicates. We used the larger among survey variance to calculate confidence intervals of bird density.

Birds Exposed to Oil

The estimated numbers of birds for each of nine species exposed to oil in July are presented in Figs. 9 - 17 based on an assumed 5,912 bbl spills and in Figs. 18 - 26 for 1,580 bbl spills. Avian exposure estimates during August are presented for 5,912 bbl spills in Figs. 27 - 35 and for a 1,580 bbl spills in Figs. 36 - 44. The top graph on each page indicates the number (frequency) of trajectories relative to the total number of birds exposed to oil summed for the entire 30-day period. All distributions were skewed to the left indicating many spills exposed relatively few birds while a few spills exposed many birds to oil. The center graph shows the mean number of birds exposed to oil each day averaged over all 500 spills. The bottom graph depicts the daily mean number of birds exposed to oil with the average calculated only for the subset of spills that remained active each day. We considered oil spillites moving southward onto the mainland coast, or trajectories moving north or east beyond the bird survey area, no longer active because they did not continue to expose more birds (in the area with density data) to oil. For example, 250 of the 500 July spills remained active on day 8, therefore we summed all birds exposed to oil on day 8 and divided by 250, rather than 500, to calculate the average. The bottom graphs also showed the mean number of birds exposed to oil per day calculated for the lower and upper 90% confidence intervals of bird density.

Birds were exposed to oil relatively early within the 30-day spill due to generally higher densities of birds closer to the spill origin at the Liberty project. The average exposure rate of birds

per day declined from day 2 to day 10 or 11 for all species except king and spectacled eider. There was a slight increase in exposure per day from days 12 to 19 and a small tertiary peak from days 22 to 25. The reasons for the secondary peaks in number of birds exposed per day are unknown. King eider and spectacled eider, occurring at greatest density in the northwestern part of the surveyed area farthest from the Liberty site, showed a different pattern in July. Increasing numbers of birds were exposed to oil up to day 14 for king eider (Figs. 11, 20) and to day 21 for spectacled eider (Figs. 13, 22).

For each species, month, and spill size, the number of birds exposed to oil was estimated at the upper 90% confidence limit, mean, and lower 90% confidence limit of bird density (Table 4). We also tabulated the results by five levels of bird-exposure severity across trajectories; the highest (maximum exposure) trajectory, the 90th percentile, the average across all trajectories, the 10th percentile, and the lowest trajectory (Table 4). Variation was due to differences among the oil trajectories and imprecision in avian population estimates. For example, the average trajectory for a 5,912 bbl oil spill during July resulted in 2,968, 1,443, and 86 long-tailed ducks being oiled based on the upper 90%, mean, and lower 90% estimates of bird density. Similarly, the average long-tailed duck density showed 3,667, 1,443, and 84 birds being exposed to oil at the 90th percentile, average, and 10th percentile among oil trajectories (Table 4). For nearly all species, months, and spill sizes, the range of variation at 90th and 10th percentile levels among spill trajectories exceeded the magnitude of variation at 90% and 10% confidence limits due to imprecision in estimated bird density (Table 4).

In July, when the amount of oil spilled per trajectory was reduced by 73% from 5,912 bbl down to 1,580 bbl, the number of long-tailed ducks exposed to oil was reduced only by 22% to an average of 1,130 birds down from 1,443 (Table 4). Similarly, with a 73% reduction in oil spilled, the number of birds exposed to oil in the other species declined only by 22-26%. In August, with 73% reduction in volume of oil spilled, the number of long-tailed ducks exposed to oil declined by 17%. Similarly, for other species in August, the number exposed to oil declined between 26% and 15%. The smaller amount of oil per spillete did not result in a proportional decrease in the number of birds exposed to oil. This non-linear response was likely due to high degree of spatial overlap among spilletes for both spill sizes and because redundant exposure of grid cells to oil did not increase the number of birds exposed to oil.

To assess potential impacts to local populations of each species, we tabulated the mean number of birds exposed to oil as a fraction of the estimated total population size in the entire surveyed area. Based on the average of all 5,912 bbl spills during July, the proportion of the total population exposed to oil was highest for glaucous gulls (7.9%) followed by long-tailed ducks (6.9%), red-throated loons (5.0%), and common eider (4.8%) (Table 5). For each of these species, the most severe trajectory, measured by oil exposure to the greatest number of birds, affected 34%, 31%, 20%, and 19% of these populations, respectively (Table 5). Spectacled eider and king eider populations were least impacted (Table 5) because of their widespread or further offshore distributions. For the other 7 species, at least 10% of the modeled trajectories (90th percentile) caused between 7% and 18% of the estimated total population of the following species to be oiled: glaucous gulls (18%), long-tailed ducks (18%), red-throated loons (13%), common eider (13%), yellow-billed loons (9%), Pacific loons (8%), and scoter species (7%) (Table 5). At the 90th percentile, a 1,580-bbl spill exposed between 6% and 13% of these species to oil.

DISCUSSION

Assessment of oil spill impacts to migratory birds is based on a combination of risk factors such as probability of a spill, spill size, spill duration, weather conditions, and effectiveness of oil spill response. While this analysis assumed that a spill of a specific size had occurred, spatial variation in spill trajectories, combined with spatial and temporal variability in bird numbers, still resulted in a wide range of possible numbers of birds exposed to oil. A single average or median estimate of the number of birds oiled does not indicate this range, nor does it facilitate assessment of risk. We

tabulated the number of birds exposed to oil for each species based on time and size of spill across 11 levels of trajectory severity (0.01, 0.1, 0.2, 0.3, 0.4, 0.5, 0.6, 0.7, 0.80, 0.9, 0.99 quantiles) for the lower 90%, mean, and upper 90% confidence levels of avian population sizes within the study area (Tables 6 - 9). This should help convey the chance that a certain number of birds might be exposed to oil. Given oil exposure, then yet another assessment would be needed to determine what number of birds would actually be killed from the exposure, and whether that number would cause a serious reduction in the population for a period of years.

The estimated numbers of birds exposed to oil by simulated oil spill trajectories, apply to a framework defined and constrained by the simulation model. Numerous assumptions and simplifications separate the model from the real world. Nevertheless, even with possible inaccuracy in the predicted numbers of birds exposed to oil, the relative magnitudes and patterns of exposure of birds to oil may have some application for management and protection of migratory bird resources. One general pattern indicated by the model results was that, on average, most spills exposed relatively few birds to oil, and relatively few spills exposed a large number of birds. Because of prevailing wind direction, many spills moved towards and stopped at the mainland coast within a short time. Half the spills in both July and August covered less than 150 km². Most exposure occurred soon after a spill due in part to the location of the Liberty project in a lagoon-nearshore-barrier island system where most migratory birds occurred in higher densities. Longer duration spills spread oil farther offshore, an area of relatively lower bird densities for all species except for king and spectacled eiders.

Less variable estimates of average density may be obtained with more replicates of aerial surveys, more rigorous delineation of stratum boundaries, or improved methods to summarize spatial pattern. The variation we observed in six offshore aerial surveys was due to the combination of differences in bird numbers among months, years, habitats, observers, survey conditions, weather conditions, and sampling error. However, even without more accurate aerial survey data, differences among spill trajectories will continue to dominate the variability in number of birds exposed to oil. Management and regulatory agencies must refine the impact assessment questions to be answered before extensive developments or modifications of aerial survey methods or analyses are worthwhile. For example, dividing the various wind direction conditions associated with spill trajectories would allow greater precision in estimating average number of birds exposed to oil.

Factors affecting numbers of birds

Definition of stratum boundaries was somewhat subjective. We tried to be conservative by tightly delineating stratum boundaries around where the nearshore and barrier island flightlines were flown and where the suspected concentrations of long-tailed ducks occurred. This likely prevented overestimation of population size caused by inadvertent expansion of a local concentration of birds into a larger area than would be appropriate. Because we only used the systematic offshore survey data, the magnitude of this potential source of bias was not a problem, although we probably increased sampling error due to the short distance of transects sections that crossed these small strata. Changing the number, size, and location of the strata would result in different estimates of bird density that would in turn affect the number of birds exposed to oil. We did not test the relative sensitivity of model output to different stratifications.

The use of the aircraft Global Positioning System connected to a laptop computer allowed relatively accurate locations (± 200 m) for all observations. However, because some of the strata are small (lagoon-side of the barrier islands), any error in locations may cause observations to fall into an adjacent stratum during the overlay process. This would result in some error in estimating the bird density for a particular stratum but, with a counteracting error in the adjacent stratum, it would cause only a small change in the overall population estimate. Bird density estimates in some strata are based on only a small number of transects crossing the stratum, making estimates of the mean and variance imprecise.

The Beaufort Sea coastline boundary used by MMS to define the southern extent of spillite movements was different from the coastline boundary that we used to fly the surveys and analyze the

data. In some sections along the coast, the oil spill paths incorrectly stopped prior to reaching or crossing the nearshore stratum (Fig 1). Consequently, birds in these locations were unable to be exposed to oil likely underestimating avian exposure in this stratum. The potential magnitude of this effect was not determined

Some oil spill trajectories moved beyond the area surveyed for birds. Trajectories extending north beyond the bird survey area would likely impact king eider however, because this species occurred in relatively low densities, any added exposure would expectedly be small. In contrast, historic bird surveys of nearshore and lagoon habitats east of Brownlow Point and into Arctic National Wildlife Refuge found significant numbers of long-tailed ducks, glaucous gulls, and common eider (Garner and Reynolds 1986). Because this area was not assessed by the 1999 and 2000 offshore waterbird surveys, impacts of oil were not determined. Thus, this report underestimated the potential impact to migratory birds. This coastal area further east should be included in future aerial surveys and analyses.

Detection rate of birds on water, especially where they occur in large flocks, is usually high. However, poor visibility due to fog, glare, or rough water can lower the detection rate, therefore surveys were not flown under very poor conditions. Certainly, birds were present but not observed, some moved beyond the strip width before they were noticed, and some birds were missed if they dove underwater before identification. Consistently overestimating the size of large flocks, double counting the same birds by both observers, or including birds observed beyond the 400-meter-wide strip width, were possible errors that could have overestimated bird numbers, but these problems were probably infrequent in comparison to underestimation errors. We did not include any adjustment for visibility bias because none has been determined. Therefore, the bird numbers reported likely represent minimum estimates of the true population sizes.

We estimated bird density averaging only 2 - 4 aerial surveys. The number of birds observed on any one aerial survey was variable due to many factors that affected visibility of birds as well as the response of birds to the survey aircraft. The actual number of birds exposed to oil would be highly variable as well. The variance among surveys was calculated for July and for August but this was based on only four or two replicates. Consistent, unbiased, systematic surveys flown for several more years to document bird distribution and abundance for the entire area potentially exposed to oil would increase our confidence in the reported range and average numbers of birds exposed to oil from analysis of the trajectory models.

Limitations of the bird - oil trajectory overlay analysis

- 1) We did not include any effects of onshore oil. Oil reaching the mainland shore stopped moving and therefore was no longer a threat to offshore birds. Once reaching the shoreline, the trajectory model did not allow oil to re-enter the water.
- 2) Barrier island shoreline-specific effects were not estimated. Oil spill paths were apparently modeled without a complete physical boundary imposed by barrier islands, although the water current force vectors did change around the barrier islands. Direct interception, accumulation, or deflection of oil by islands did not appear to occur. Particularly for molting long-tailed ducks that repeatedly used these barrier islands for roosting and protection from wind, any concentration or pooling of oil on the lee side of the barrier islands could greatly increase the number of long-tailed ducks exposed to oil.
- 3) The influence of ice on the oil trajectories was not included in the model for July and August. Particularly early in July, ice may still concentrate both the birds and oil.
- 4) Long-term, secondary, or indirect effects were not estimated. For example, changes in food distribution or availability, disturbance associated with oil spill response, or sub-lethal effects on survival and productivity were not included. We measured exposure to oil as an all-or-none response. Oil exposure was considered equivalent to an immediate lethal effect.
- 5) We estimated and expressed the number of birds exposed to oil considering the spatial and temporal pattern imposed by the spill simulation model, however we considered that the effect

of oil exposure on birds was constant. The model did not include any quantitative change due to declining toxicity over time or changing properties of the oil under different time, temperature, or wind conditions.

- 6) We assumed no residual effect of oil once it passed a location. The path the oil followed did not remain harmful to birds for any period longer than when the first spillete of oil was present at that location.
- 7) The model did not account for any movement by birds. Because long-tailed ducks are molting and flightless from early-July to mid-September, there probably was little long-range movement by these birds. However, molting birds disperse to feeding locations away from the barrier islands during the morning and return to roosting/preening locations near the barrier islands in the evening. Other species may actively fly and swim considerable distances during a day. Molt migrating, failed-nesting, or post-breeding birds may pass through or stage for brief periods within the study area. However, the effects of immigration and emigration relative to potential avian injury and exposure from an oil spill were not assessed. The population was interpreted as a uniform series of stationary points at 50m or 25m spacing with a numeric value equivalent to the average fractional density indicated by the aerial survey data within each stratum. As oil spilletes moved along their stair-stepped grid cell routes, they accumulated all fractional birds from each oiled cell. We did not account for any bird movement, either within the hour time step of the oil model or during the time it takes oil to move between grid cells.
- 8) Birds are in reality integer-sized units, and for many species, occur in larger flocks or in spatially correlated clumps. The conversion of whole birds into fractional birds per grid cell assumed a uniformly distributed population across all grid cells in each stratum. The clumped pattern of birds and flocks was ignored. The mean number of birds exposed to oil after accumulation by a large number of spillete paths probably was not biased because of fractional bird densities, although the variance of the number of birds exposed was likely underestimated.
- 9) The model did not include any interaction component between birds and oil, i.e., the bird and oil distributions were assumed completely independent. Certain climatic conditions could cause similar (or opposite) patterns in the distribution or movements of both birds and oil. Similarly, the model did not include potential detection and avoidance of oil by birds.

Recommendations for further work

- 1) Incorporate additional aerial survey data sets into the estimates of bird density and compare results between survey types/years.
- 2) Modify the existing aerial survey design to ensure systematic and unbiased estimates for both bird distribution and abundance. Improve sampling intensity by flying systematic lines at closer spacing in specific strata (e.g., within 10 km of the coast) as opposed to sampling further offshore where bird density is lower and contributes less variance.
- 3) Examine alternative stratifications or smoothing techniques for bird density and compare any effects on model output.
- 4) Explore other overlay model structures with additional variables, interaction terms, or refinements. A stochastic model could be constructed to include distribution, abundance, flock size, and movement patterns of birds as well as oil spill locations.
- 5) Examine other ways of expressing the large variation among trajectories in the number of birds exposed to oil.
- 6) Define the actual management uses for models to better construct a model to answer specific management questions. For example, a model that predicted the number of birds exposed to oil given the direction and speed of the wind on the day the spill occurred might be useful for management decisions regarding the allocation of resources or the timing of clean-up efforts.

- 7) Design or improve data collection methods to document indirect and long-term effects of oil spills and associated disturbance on waterfowl and their habitats in the Beaufort Sea.
- 8) Conduct aerial surveys or devise alternate methods for data collection that would document the spatial and temporal use of Beaufort Sea nearshore and offshore habitats by eider, long-tailed ducks, and gulls during migration in June and September as well as July and August.
- 9) Conduct aerial surveys or devise alternate methods for data collection that would document the spatial and temporal use of Beaufort Sea nearshore and shoreline habitats by shorebirds and phalaropes.

Literature and reports cited

- Butler, W.I., Jr., R.A. Stehn, and G.R. Balogh. 1995. GIS for mapping waterfowl density and distribution from aerial surveys. *Wildl. Soc. Bull.* 23:140-147.
- Butler, W.I., Jr., J.I. Hodges, and R.A. Stehn. 1995. Locating waterfowl observations on aerial surveys. *Wildl. Soc. Bull.* 23:148-154.
- Conant, B., J.I. Hodges, and D.J. Groves. 2000. Alaska-Yukon waterfowl breeding population survey. Unpubl. USFWS report, July 2000, Juneau. 31pp.
- Garner, G.W. and P.R. Reynolds. 1986. Final Report Baseline Study of the Fish, Wildlife, and their Habitats, Section 1002C. USFWS report, Anchorage, 392pp.
- Johnson, S.R. and W.J. Gazey. 1992. Design and testing of a monitoring program for Beaufort Sea waterfowl and marine birds. Unpubl. report for Minerals Management Service prepared by LGL Limited, Sidney B.C. 114pp.
- Larned, W.W., T. Tiplady, R. Platte, and R. Stehn. 1999. Eider breeding population survey arctic coastal plain, Alaska, 1997-98. Unpubl. USFWS report, Jan 1999, Anchorage. 22pp.
- Mallek, E.J. and R.J. King. 2000. Aerial breeding pair surveys of the arctic coastal plain of Alaska. Unpubl. USFWS report, May 2000, Fairbanks. 17pp.
- MMS. 2000. Liberty oil spill trajectory model runs for the Fish and Wildlife Service and the USGS, Biological Research Division. Unpubl. MMS report, June 2000. 26pp.
- Noel, L.E. 1999. Aerial surveys of molting waterfowl in the barrier island-lagoon systems between Spy Island and Brownlow Point, Alaska, 1999. Final Report for BP Exploration (Alaska) Inc. prepared by LGL Alaska Research Associates, Inc., Anchorage, and LGL Limited, Sidney BC, May 1999. 108pp.
- USFWS. 1999. Population status and trends of seaducks in Alaska. Unpubl. USFWS report, April 1999, Anchorage. 137pp.

Table 2. Population estimates of total birds observed based on central Beaufort Sea offshore aerial surveys flown beginning on 28 June 1999, 27 July 1999, 24 June 2000, and 25 July 2000. Each 3-4 day survey included systematic north-south transects crossing 50 polygons categorized into 22 strata based on habitat and geographic location. Jack-knifed variance estimates were calculated among surveys with weights proportional to the transect area observed in each replicate.

stratum name	stratum	area sqkm	Number transects	Transect sampled area sqkm	Long-tailed Duck					Glaucous Gull									
					N obs	Density	Pop.Index	SE pop	CV	N obs	Density	Pop.Index	SE pop	CV					
Shoreline - East	1	76.9	37	9.2	653	73.75	5669	4195	0.740	24	2.53	194	81	0.415					
Shoreline - Center	7	42.4	15	8.8	0	0.00	0	0	0.000	136	15.29	648	328	0.506					
Shoreline - Industrial	12	47.2	41	7.7	71	9.07	428	320	0.748	2	0.26	12	7	0.593					
Shoreline - Colville	19	23.7	26	5.9	1	0.17	4	4	1.021	7	1.20	28	29	1.023					
Shoreline - West	18	32.3	25	6.6	16	2.44	79	75	0.949	9	1.36	44	10	0.235					
Barrier Island protected - East	3	30.5	12	3.4	112	32.30	984	1028	1.045	21	6.09	185	137	0.741					
Barrier Island protected - Center	10	17.9	7	2.6	17	6.55	118	118	1.008	11	4.26	76	47	0.621					
Barrier Island protected - Industrial	15	25.9	23	6.1	41	6.84	177	118	0.665	26	4.31	112	112	1.005					
Barrier Island protected - West	21	4.4	3	0.5	0	0.00	0	0	0.000	1	2.03	9	9	1.009					
Barrier Island pass - East	4	19.1	8	3.2	0	0.00	0	0	0.000	0	0.00	0	0	0.000					
Barrier Island pass - Center	9	53.1	34	14.4	56	3.86	205	205	1.003	2	0.14	7	4	0.550					
Barrier Island pass - Industrial	14	24.1	21	8.5	5	0.61	15	15	1.006	44	5.15	124	65	0.523					
Mid-lagoon - Center	8	750.2	39	189.6	1292	6.79	5092	2949	0.579	119	0.63	475	183	0.385					
Mid-lagoon - East	2	300.9	24	67.0	495	7.36	2216	1215	0.548	9	0.13	40	26	0.670					
Mid-lagoon - Industrial	13	223.8	44	61.3	286	4.65	1040	665	0.639	11	0.18	40	12	0.289					
Nearshore marine - East	5	130.6	22	25.5	314	12.15	1586	1448	0.913	1	0.04	5	5	1.063					
Nearshore marine - Center	11	126.3	35	39.2	71	1.82	230	141	0.612	0	0.00	0	0	0.000					
Nearshore marine - Industrial	16	192.3	45	59.4	68	1.14	220	149	0.678	11	0.18	36	19	0.540					
Nearshore marine - West	20	1483.9	58	427.0	700	1.64	2436	1907	0.783	134	0.31	466	119	0.255					
Offshore marine - East	6	4914.2	57	783.8	48	0.06	286	214	0.749	11	0.01	71	43	0.607					
Offshore marine - Center	17	4312.7	62	1121.8	41	0.04	157	104	0.660	27	0.02	104	48	0.465					
Offshore marine - West	22	2341.6	42	628.1	14	0.02	52	52	1.000	19	0.03	70	56	0.791					
Total =		15174.0	680	3479.7	4301	1.38	20994	5940	0.283	625	0.18	2748	457	0.166					
					King Eider					Common Eider					Spectacled Eider				
					N obs	Density	Pop.Index	SE pop	CV	N obs	Density	Pop.Index	SE pop	CV	N obs	Density	Pop.Index	SE pop	CV
Shoreline - East					4	0.41	31	32	1.028	4	0.42	32	21	0.656	0	0.00	0	0	0.000
Shoreline - Center					2	0.23	10	10	1.006	10	1.14	48	38	0.787	0	0.00	0	0	0.000
Shoreline - Industrial					0	0.00	0	0	0.000	0	0.00	0	0	0.000	0	0.00	0	0	0.000
Shoreline - Colville					0	0.00	0	0	0.000	0	0.00	0	0	0.000	0	0.00	0	0	0.000
Shoreline - West					1	0.15	5	5	1.034	0	0.00	0	0	0.000	0	0.00	0	0	0.000
Barrier Island protected - East					0	0.00	0	0	0.000	8	2.29	70	75	1.072	0	0.00	0	0	0.000
Barrier Island protected - Center					0	0.00	0	0	0.000	1	0.39	7	7	1.009	0	0.00	0	0	0.000
Barrier Island protected - Industrial					1	0.17	4	4	1.004	8	1.29	33	33	1.000	0	0.00	0	0	0.000
Barrier Island protected - West					0	0.00	0	0	0.000	0	0.00	0	0	0.000	0	0.00	0	0	0.000
Barrier Island pass - East					0	0.00	0	0	0.000	0	0.00	0	0	0.000	0	0.00	0	0	0.000
Barrier Island pass - Center					0	0.00	0	0	0.000	1	0.07	4	4	1.003	0	0.00	0	0	0.000
Barrier Island pass - Industrial					0	0.00	0	0	0.000	40	4.60	111	112	1.011	0	0.00	0	0	0.000
Mid-lagoon - Center					9	0.05	36	31	0.874	88	0.47	349	75	0.216	0	0.00	0	0	0.000
Mid-lagoon - East					7	0.11	33	34	1.023	59	0.91	272	146	0.535	0	0.00	0	0	0.000
Mid-lagoon - Industrial					0	0.00	0	0	0.000	9	0.15	33	33	1.006	0	0.00	0	0	0.000
Nearshore marine - East					21	0.80	105	111	1.064	32	1.23	161	45	0.282	0	0.00	0	0	0.000
Nearshore marine - Center					113	2.88	363	311	0.855	15	0.39	49	49	1.000	0	0.00	0	0	0.000
Nearshore marine - Industrial					4	0.07	13	13	1.000	102	1.72	330	133	0.402	0	0.00	0	0	0.000
Nearshore marine - West					338	0.79	1176	766	0.651	279	0.65	968	818	0.845	1	0.00	3	3	1.000
Offshore marine - East					952	1.26	6201	6385	1.030	92	0.11	560	276	0.493	0	0.00	0	0	0.000
Offshore marine - Center					878	0.79	3411	2208	0.647	64	0.06	247	194	0.785	43	0.04	166	166	1.003
Offshore marine - West					2253	3.61	8454	5104	0.604	7	0.01	26	26	1.000	100	0.16	371	371	1.001
Total =					4583	1.31	19842	8508	0.429	819	0.22	3300	924	0.280	144	0.04	540	407	0.753

Table 2 (continued). Population estimates of total birds observed based on central Beaufort Sea offshore aerial surveys flown beginning on 28 June 1999, 27 July 1999, 24 June 2000, and 25 July 2000. Each 3-4 day survey included systematic north-south transects crossing 50 polygons categorized into 22 strata based on habitat and geographic location. Jack-knifed variance estimates were calculated among surveys with weights proportional to the transect area observed in each replicate.

stratum name	Stratum stratum area sqkm	Number transects	Transect sampled area sqkm	Pacific Loon					Red-throated Loon					
				N obs	Density	Pop.Index	SE pop	CV	N obs	Density	Pop.Index	SE pop	CV	
Shoreline - East	1	76.9	37	9.2	0	0.00	0	0	0.000	0	0.00	0	0	0.000
Shoreline – Center	7	42.4	15	8.8	0	0.00	0	0	0.000	2	0.22	9	9	1.002
Shoreline – Industrial	12	47.2	41	7.7	0	0.00	0	0	0.000	0	0.00	0	0	0.000
Shoreline – Colville	19	23.7	26	5.9	0	0.00	0	0	0.000	0	0.00	0	0	0.000
Shoreline – West	18	32.3	25	6.6	1	0.15	5	5	1.027	0	0.00	0	0	0.000
Barrier Island protected - East	3	30.5	12	3.4	0	0.00	0	0	0.000	0	0.00	0	0	0.000
Barrier Island protected - Center	10	17.9	7	2.6	0	0.00	0	0	0.000	0	0.00	0	0	0.000
Barrier Island protected - Industrial	15	25.9	23	6.1	2	0.33	9	5	0.620	0	0.00	0	0	0.000
Barrier Island protected - West	21	4.4	3	0.5	0	0.00	0	0	0.000	0	0.00	0	0	0.000
Barrier Island pass - East	4	19.1	8	3.2	0	0.00	0	0	0.000	0	0.00	0	0	0.000
Barrier Island pass – Center	9	53.1	34	14.4	0	0.00	0	0	0.000	0	0.00	0	0	0.000
Barrier Island pass - Industrial	14	24.1	21	8.5	2	0.23	6	6	1.010	0	0.00	0	0	0.000
Mid-lagoon – Center	8	750.2	39	189.6	16	0.08	63	16	0.254	7	0.04	27	12	0.432
Mid-lagoon – East	2	300.9	24	67.0	9	0.13	40	26	0.636	1	0.01	4	4	1.021
Mid-lagoon – Industrial	13	223.8	44	61.3	10	0.16	37	17	0.473	4	0.06	14	10	0.675
Nearshore marine - East	5	130.6	22	25.5	0	0.00	0	0	0.000	0	0.00	0	0	0.000
Nearshore marine – Center	11	126.3	35	39.2	1	0.03	3	3	1.000	2	0.05	6	6	1.000
Nearshore marine - Industrial	16	192.3	45	59.4	7	0.12	23	13	0.593	2	0.03	6	6	1.000
Nearshore marine – West	20	1483.9	58	427.0	56	0.13	195	62	0.319	11	0.03	38	17	0.450
Offshore marine - East	6	4914.2	57	783.8	31	0.04	191	81	0.423	6	0.01	35	35	1.014
Offshore marine – Center	17	4312.7	62	1121.8	33	0.03	127	82	0.650	2	0.00	8	4	0.556
Offshore marine – West	22	2341.6	42	628.1	18	0.03	67	52	0.780	4	0.01	15	15	1.000
Total =	15174.0	680	3479.7		186	0.05	764	146	0.191	41	0.01	164	47	0.286
	Yellow-billed Loon					Scoter species								
	N obs	Density	Pop.Index	SE pop	CV	N obs	Density	Pop.Index	SE pop	CV				
Shoreline - East	1	0.10	8	8	1.028	4	0.42	32	18	0.563				
Shoreline – Center	0	0.00	0	0	0.000	0	0.00	0	0	0.000				
Shoreline – Industrial	0	0.00	0	0	0.000	0	0.00	0	0	0.000				
Shoreline – Colville	0	0.00	0	0	0.000	0	0.00	0	0	0.000				
Shoreline – West	1	0.15	5	5	1.036	1	0.15	5	5	1.034				
Barrier Island protected - East	0	0.00	0	0	0.000	0	0.00	0	0	0.000				
Barrier Island protected - Center	0	0.00	0	0	0.000	3	1.16	21	21	1.009				
Barrier Island protected - Industrial	0	0.00	0	0	0.000	0	0.00	0	0	0.000				
Barrier Island protected - West	0	0.00	0	0	0.000	0	0.00	0	0	0.000				
Barrier Island pass - East	0	0.00	0	0	0.000	0	0.00	0	0	0.000				
Barrier Island pass – Center	0	0.00	0	0	0.000	0	0.00	0	0	0.000				
Barrier Island pass - Industrial	0	0.00	0	0	0.000	7	0.81	19	9	0.478				
Mid-lagoon – Center	4	0.02	16	11	0.690	131	0.69	519	262	0.504				
Mid-lagoon – East	0	0.00	0	0	0.000	71	1.03	310	199	0.645				
Mid-lagoon – Industrial	0	0.00	0	0	0.000	119	1.92	429	275	0.641				
Nearshore marine - East	0	0.00	0	0	0.000	0	0.00	0	0	0.000				
Nearshore marine – Center	1	0.03	3	3	1.000	0	0.00	0	0	0.000				
Nearshore marine - Industrial	1	0.02	3	3	1.000	3	0.05	10	10	1.000				
Nearshore marine – West	13	0.03	45	23	0.508	754	1.76	2616	1910	0.730				
Offshore marine - East	0	0.00	0	0	0.000	25	0.03	150	91	0.608				
Offshore marine - Center	1	0.00	4	4	1.000	119	0.11	458	459	1.002				
Offshore marine - West	3	0.00	11	7	0.667	66	0.10	245	245	1.001				
Total =	25	0.01	95	29	0.302	1303	0.32	4814	2028	0.421				

able 3. Population estimates of total birds observed based on central Beaufort Sea offshore aerial surveys flown beginning on 31 August 1999 and 5 August 2000. Each 3-4 day survey included systematic north-south transects crossing 50 polygons categorized into 22 strata based on habitat and eographic location. Variance estimates were calculated among surveys with weights proportional to the transect area observed in each replicate.

stratum name	stratum	Stratum area sqkm	Number transects	Transect sampled area sqkm	Long-tailed Duck					Glaucous Gull					
					N obs	Density	Pop.Index	SE pop	CV	N obs	Density	Pop.Index	SE pop	CV	
Shoreline - East	1	76.9	21	3.2	70	18.66	1434	575	0.401	7	2.89	222	122	0.548	
Shoreline - Center	7	42.4	5	1.4	0	0.00	0	0	0.000	2	1.60	68	25	0.368	
Shoreline - Industrial	12	47.2	25	3.3	0	0.00	0	0	0.000	2	0.48	23	23	1.000	
Shoreline - Colville	19	23.7	17	2.2	0	0.00	0	0	0.000	2	0.85	20	20	1.000	
Shoreline - West	18	32.3	22	5.0	0	0.00	0	0	0.000	11	2.56	83	42	0.510	
Barrier Island protected - East	3	30.5	7	1.7	32	16.71	509	104	0.204	2	0.75	23	23	1.000	
Barrier Island protected - Center	10	17.9	4	1.1	17	18.91	339	339	1.000	2	2.23	40	40	1.000	
Barrier Island protected - Industrial	15	25.9	17	2.8	53	18.58	482	298	0.618	9	3.16	82	27	0.327	
Barrier Island protected - West	21	4.4	2	0.3	0	0.00	0	0	0.000	1	2.01	9	9	1.000	
Barrier Island pass - East	4	19.1	5	1.7	6	8.26	157	157	1.000	0	0.00	0	0	0.000	
Barrier Island pass - Center	9	53.1	23	7.7	150	19.85	1053	1053	1.000	4	0.53	28	28	1.000	
Barrier Island pass - Industrial	14	24.1	14	5.0	64	12.65	305	48	0.157	15	2.99	72	0	0.003	
Mid-lagoon - Center	8	750.2	25	79.5	94	1.17	877	147	0.168	22	0.29	218	147	0.676	
Mid-lagoon - East	2	300.9	15	31.1	1722	58.14	17497	12648	0.723	3	0.10	31	31	1.000	
Mid-lagoon - Industrial	13	223.8	31	33.5	153	4.62	1033	901	0.872	31	0.92	205	151	0.736	
Nearshore marine - East	5	130.6	14	13.2	12	0.60	78	78	1.000	1	0.16	21	21	1.000	
Nearshore marine - Center	11	126.3	27	19.6	132	6.66	841	553	0.657	1	0.05	6	6	1.000	
Nearshore marine - Industrial	16	192.3	34	29.1	30	1.04	201	136	0.677	29	0.98	189	162	0.857	
Nearshore marine - West	20	1483.9	45	217.8	1117	5.13	7616	1801	0.236	35	0.16	239	35	0.146	
Offshore marine - East	6	4914.2	64	490.8	227	0.41	1997	1003	0.502	1	0.00	14	14	1.000	
Offshore marine - Center	17	4312.7	57	562.3	165	0.29	1270	272	0.214	9	0.02	69	9	0.125	
Offshore marine - West	22	2341.6	29	318.1	279	0.90	2101	1347	0.641	9	0.03	69	69	1.000	
Total =	23	15174.0	503	1830.4	4323	2.49	37792	12999	0.344	198	0.11	1730	316	0.183	
	King Eider					Common Eider					Spectacled Eider				
	N obs	Density	Pop.Index	SE pop	CV	N obs	Density	Pop.Index	SE pop	CV	N obs	Density	Pop.Index	SE pop	CV
Shoreline - East	0	0.00	0	0	0.000	0	0.00	0	0	0.000	0	0.00	0	0	0.000
Shoreline - Center	0	0.00	0	0	0.000	0	0.00	0	0	0.000	0	0.00	0	0	0.000
Shoreline - Industrial	0	0.00	0	0	0.000	0	0.00	0	0	0.000	0	0.00	0	0	0.000
Shoreline - Colville	0	0.00	0	0	0.000	0	0.00	0	0	0.000	0	0.00	0	0	0.000
Shoreline - West	64	10.04	324	324	1.000	0	0.00	0	0	0.000	0	0.00	0	0	0.000
Barrier Island protected - East	0	0.00	0	0	0.000	4	4.36	133	110	0.829	0	0.00	0	0	0.000
Barrier Island protected - Center	0	0.00	0	0	0.000	0	0.00	0	0	0.000	0	0.00	0	0	0.000
Barrier Island protected - Industrial	0	0.00	0	0	0.000	1	0.35	9	9	1.000	0	0.00	0	0	0.000
Barrier Island protected - West	0	0.00	0	0	0.000	0	0.00	0	0	0.000	0	0.00	0	0	0.000
Barrier Island pass - East	0	0.00	0	0	0.000	41	56.41	1075	1075	1.000	0	0.00	0	0	0.000
Barrier Island pass - Center	0	0.00	0	0	0.000	0	0.00	0	0	0.000	0	0.00	0	0	0.000
Barrier Island pass - Industrial	0	0.00	0	0	0.000	3	0.56	14	14	1.000	0	0.00	0	0	0.000
Mid-lagoon - Center	0	0.00	0	0	0.000	4	0.05	35	35	1.000	0	0.00	0	0	0.000
Mid-lagoon - East	0	0.00	0	0	0.000	14	0.48	145	145	1.000	0	0.00	0	0	0.000
Mid-lagoon - Industrial	0	0.00	0	0	0.000	0	0.00	0	0	0.000	0	0.00	0	0	0.000
Nearshore marine - East	0	0.00	0	0	0.000	0	0.00	0	0	0.000	0	0.00	0	0	0.000
Nearshore marine - Center	0	0.00	0	0	0.000	0	0.00	0	0	0.000	0	0.00	0	0	0.000
Nearshore marine - Industrial	0	0.00	0	0	0.000	0	0.00	0	0	0.000	0	0.00	0	0	0.000
Nearshore marine - West	124	0.57	845	147	0.174	3	0.01	20	7	0.333	0	0.00	0	0	0.000
Offshore marine - East	25	0.07	321	258	0.804	1	0.00	8	8	1.000	0	0.00	0	0	0.000
Offshore marine - Center	28	0.05	213	104	0.490	5	0.01	38	38	1.000	0	0.00	0	0	0.000
Offshore marine - West	656	2.13	4994	4710	0.943	0	0.00	0	0	0.000	4	0.01	30	30	1.000
Total =	897	0.44	6698	4732	0.706	76	0.10	1477	1092	0.739	4	0.00	30	30	1.000

Table 3 (continued). Population estimates of total birds observed based on central Beaufort Sea offshore aerial surveys flown beginning on 31 August 1999 and 25 August 2000. Each 3-4 day survey included systematic north-south transects crossing 50 polygons categorized into 22 strata based on habitat and geographic location. Variance estimates were calculated among surveys with weights proportional to the transect area observed in each replicate.

stratum name	Stratum				Pacific Loon					Red-throated Loon					
	stratum	area sqkm	Number transects	Transect sampled area sqkm	N obs	Density	Pop.Index	SE pop	CV	N obs	Density	Pop.Index	SE pop	CV	
Shoreline - East	1	76.9	21	3.2	0	0.00	0	0	0.000	0	0.00	0	0	0.000	
Shoreline – Center	7	42.4	5	1.4	0	0.00	0	0	0.000	0	0.00	0	0	0.000	
Shoreline – Industrial	12	47.2	25	3.3	0	0.00	0	0	0.000	0	0.00	0	0	0.000	
Shoreline – Colville	19	23.7	17	2.2	0	0.00	0	0	0.000	2	0.85	20	20	1.000	
Shoreline – West	18	32.3	22	5.0	0	0.00	0	0	0.000	2	0.31	10	10	1.000	
Barrier Island protected - East	3	30.5	7	1.7	0	0.00	0	0	0.000	0	0.00	0	0	0.000	
Barrier Island protected - Center	10	17.9	4	1.1	0	0.00	0	0	0.000	0	0.00	0	0	0.000	
Barrier Island protected - Industrial	15	25.9	17	2.8	0	0.00	0	0	0.000	0	0.00	0	0	0.000	
Barrier Island protected - West	21	4.4	2	0.3	0	0.00	0	0	0.000	0	0.00	0	0	0.000	
Barrier Island pass - East	4	19.1	5	1.7	0	0.00	0	0	0.000	0	0.00	0	0	0.000	
Barrier Island pass – Center	9	53.1	23	7.7	0	0.00	0	0	0.000	0	0.00	0	0	0.000	
Barrier Island pass - Industrial	14	24.1	14	5.0	1	0.19	5	5	1.000	0	0.00	0	0	0.000	
Mid-lagoon – Center	8	750.2	25	79.5	2	0.02	18	18	1.000	1	0.01	9	9	1.000	
Mid-lagoon – East	2	300.9	15	31.1	3	0.10	31	31	1.000	1	0.03	10	10	1.000	
Mid-lagoon – Industrial	13	223.8	31	33.5	9	0.27	60	6	0.099	0	0.00	0	0	0.000	
Nearshore marine - East	5	130.6	14	13.2	0	0.00	0	0	0.000	0	0.00	0	0	0.000	
Nearshore marine – Center	11	126.3	27	19.6	0	0.00	0	0	0.000	0	0.00	0	0	0.000	
Nearshore marine - Industrial	16	192.3	34	29.1	0	0.00	0	0	0.000	0	0.00	0	0	0.000	
Nearshore marine – West	20	1483.9	45	217.8	31	0.14	211	76	0.357	7	0.03	48	20	0.427	
Offshore marine - East	6	4914.2	64	490.8	8	0.02	105	89	0.850	3	0.01	41	41	1.000	
Offshore marine – Center	17	4312.7	57	562.3	12	0.02	91	60	0.659	2	0.00	15	15	1.000	
Offshore marine – West	22	2341.6	29	318.1	20	0.06	145	54	0.370	2	0.01	15	15	1.000	
Total =	23	15174.0	503	1830.4	86	0.04	666	146	0.220	20	0.01	169	57	0.339	
	Yellow-billed Loon					Scoter species									
	N obs	Density	Pop.Index	SE pop	CV	N obs	Density	Pop.Index	SE pop	CV					
Shoreline - East	0	0.00	0	0	0.000	0	0.00	0	0	0.000					
Shoreline – Center	0	0.00	0	0	0.000	0	0.00	0	0	0.000					
Shoreline – Industrial	0	0.00	0	0	0.000	0	0.00	0	0	0.000					
Shoreline – Colville	1	0.42	10	10	1.000	0	0.00	0	0	0.000					
Shoreline – West	0	0.00	0	0	0.000	1	0.16	5	5	1.000					
Barrier Island protected - East	0	0.00	0	0	0.000	0	0.00	0	0	0.000					
Barrier Island protected - Center	0	0.00	0	0	0.000	0	0.00	0	0	0.000					
Barrier Island protected - Industrial	0	0.00	0	0	0.000	0	0.00	0	0	0.000					
Barrier Island protected - West	0	0.00	0	0	0.000	0	0.00	0	0	0.000					
Barrier Island pass - East	0	0.00	0	0	0.000	0	0.00	0	0	0.000					
Barrier Island pass – Center	0	0.00	0	0	0.000	0	0.00	0	0	0.000					
Barrier Island pass - Industrial	0	0.00	0	0	0.000	2	0.38	9	9	1.000					
Mid-lagoon – Center	0	0.00	0	0	0.000	0	0.00	0	0	0.000					
Mid-lagoon – East	0	0.00	0	0	0.000	0	0.00	0	0	0.000					
Mid-lagoon – Industrial	0	0.00	0	0	0.000	51	1.51	339	176	0.521					
Nearshore marine - East	0	0.00	0	0	0.000	0	0.00	0	0	0.000					
Nearshore marine – Center	0	0.00	0	0	0.000	1	0.05	7	7	1.000					
Nearshore marine - Industrial	0	0.00	0	0	0.000	8	0.27	52	52	1.000					
Nearshore marine – West	1	0.00	7	7	1.000	421	1.93	2863	1906	0.666					
Offshore marine - East	0	0.00	0	0	0.000	27	0.04	212	212	1.000					
Offshore marine – Center	0	0.00	0	0	0.000	1	0.00	8	8	1.000					
Offshore marine – West	0	0.00	0	0	0.000	0	0.00	0	0	0.000					
Total =	2	0.00	17	12	0.720	512	0.23	3494	1927	0.551					

Table 4. Total birds exposed to oil summed over 30 days for July and August oil spill trajectory models. The range of model results are shown by the interaction of variation in both bird density (upper 90% confidence interval, **mean**, and lower 90% C.I.) and spill trajectory severity (maximum, 90% quantile, **average**, 10% quantile, and minimum exposure).

Bird Density:	Upper 90% C.I. bird density					Mean bird density					Lower 90% C.I. bird density					ratio of 25m : 50m
Oil spill trajectory:	most	90%high	average	10%low	least	most	90%high	average	10%low	least	most	90%high	average	10%low	least	
July trajectories - 50 m grid cells																
Long-tailed Duck	13795	7744	2968	168	50	6498	3667	1443	84	25	382	209	86	4	1	
Glaucous Gull	1671	870	389	16	3	939	487	217	10	2	219	119	51	3	1	
King Eider	7549	1746	581	2	0	3102	679	232	1	0	157	34	11	0	0	
Common Eider	1172	765	281	7	2	618	425	159	5	1	243	154	58	2	1	
Spectacled Eider	139	10	5	0	0	52	2	2	0	0	1	0	0	0	0	
Pacific Loon	260	105	40	1	0	147	62	23	1	0	40	19	8	0	0	
Red-throated Loon	72	48	19	1	0	33	21	8	0	0	7	3	1	0	0	
Yellow-billed Loon	33	20	8	0	0	15	8	3	0	0	0	0	0	0	0	
Scoter species	1450	657	289	10	3	668	342	147	5	2	70	48	18	1	0	
July trajectories - 25 m grid cells																
Long-tailed Duck	9756	5827	2319	152	41	4653	2810	1130	77	20	287	163	67	4	1	0.783
Glaucous Gull	1282	646	305	14	3	724	363	170	9	2	173	94	40	3	1	0.784
King Eider	5688	1358	430	2	0	2338	523	172	1	0	120	24	8	0	0	0.738
Common Eider	848	571	213	7	1	491	322	121	5	1	198	114	45	2	1	0.761
Spectacled Eider	106	6	3	0	0	40	0	1	0	0	0	0	0	0	0	0.654
Pacific Loon	184	77	30	1	0	105	45	18	1	0	25	15	6	0	0	0.756
Red-throated Loon	56	36	14	1	0	27	16	6	0	0	5	2	1	0	0	0.759
Yellow-billed Loon	29	16	6	0	0	11	6	2	0	0	0	0	0	0	0	0.748
Scoter species	979	503	219	9	3	444	264	112	5	2	58	35	14	1	0	0.764
August trajectories - 50 m grid cells																
Long-tailed Duck	28640	15825	4380	28	5	13281	7365	2062	22	4	1083	411	185	13	3	
Glaucous Gull	1042	452	150	12	2	498	229	72	6	1	94	40	10	0	0	
King Eider	307	58	19	0	0	152	25	8	0	0	22	1	1	0	0	
Common Eider	3324	1452	330	1	0	1272	555	125	0	0	13	6	1	0	0	
Spectacled Eider	1	0	0	0	0	0	0	0	0	0	0	0	0	0	0	
Pacific Loon	176	50	21	1	0	82	26	9	0	0	27	9	2	0	0	
Red-throated Loon	53	15	7	0	0	16	6	2	0	0	0	0	0	0	0	
Yellow-billed Loon	0	0	0	0	0	0	0	0	0	0	0	0	0	0	0	
Scoter species	609	198	47	0	0	270	97	22	0	0	28	10	2	0	0	
August trajectories - 25 m grid cells																
Long-tailed Duck	20367	13919	3633	25	4	9447	6442	1710	20	3	823	342	153	11	2	0.830
Glaucous Gull	804	368	124	10	2	382	180	59	5	1	72	28	8	0	0	0.821
King Eider	215	45	14	0	0	106	21	6	0	0	12	1	0	0	0	0.741
Common Eider	2995	1154	279	1	0	1144	439	106	0	0	12	5	1	0	0	0.846
Spectacled Eider	1	0	0	0	0	0	0	0	0	0	0	0	0	0	0	
Pacific Loon	121	42	17	1	0	57	20	8	0	0	21	6	1	0	0	0.808
Red-throated Loon	36	12	6	0	0	13	4	2	0	0	0	0	0	0	0	0.789
Yellow-billed Loon	0	0	0	0	0	0	0	0	0	0	0	0	0	0	0	
Scoter species	437	146	36	0	0	194	69	17	0	0	21	6	1	0	0	0.759

Table 5. Total number of birds of 9 species estimated by aerial surveys, the number of birds exposed to oil, and the proportion of the total bird population exposed to 500 modeled trajectories of a 5,912 barrel spill (50m grid cells) and a 1,580 barrel spill (25m grid cells) from the Liberty Project site. The impact of oil is shown for a range of severity in spill trajectories that included the maximum, 90% quantile, average, 10% quantile, and minimum exposure to oil.

Species	Total bird population		Number of birds exposed to oil					Proportion of total population exposed to oil				
	SE	pop	maximum	90%high	average	10%low	least	maximum	90%high	average	10%low	least
July trajectories – 50 m grid cells												
Long-tailed Duck	20994	5940	6498	3667	1443	84	25	0.310	0.175	0.069	0.004	0.001
Glaucous Gull	2748	457	939	487	217	10	2	0.342	0.177	0.079	0.004	0.001
King Eider	19842	8508	3102	679	232	1	0	0.156	0.034	0.012	0.000	0.000
Common Eider	3300	924	618	425	159	5	1	0.187	0.129	0.048	0.002	0.000
Spectacled Eider	540	407	52	2	2	0	0	0.096	0.004	0.003	0.000	0.000
Pacific Loon	764	146	147	62	23	1	0	0.192	0.081	0.030	0.001	0.000
Red-throated Loon	164	47	33	21	8	0	0	0.201	0.128	0.050	0.000	0.000
Yellow-billed Loon	95	29	15	8	3	0	0	0.157	0.085	0.032	0.000	0.000
Scoter species	4814	2028	668	342	147	5	2	0.139	0.071	0.031	0.001	0.000
July trajectories - 25 m grid cells												
Long-tailed Duck	20994	5940	4653	2810	1130	77	20	0.222	0.134	0.054	0.004	0.001
Glaucous Gull	2748	457	724	363	170	9	2	0.264	0.132	0.062	0.003	0.001
King Eider	19842	8508	2338	523	172	1	0	0.118	0.026	0.009	0.000	0.000
Common Eider	3300	924	491	322	121	5	1	0.149	0.098	0.037	0.002	0.000
Spectacled Eider	540	407	40	0	1	0	0	0.074	0.000	0.002	0.000	0.000
Pacific Loon	764	146	105	45	18	1	0	0.137	0.059	0.023	0.001	0.000
Red-throated Loon	164	47	27	16	6	0	0	0.164	0.098	0.038	0.000	0.000
Yellow-billed Loon	95	29	11	6	2	0	0	0.115	0.063	0.024	0.000	0.000
Scoter species	4814	2028	444	264	112	5	2	0.092	0.055	0.023	0.001	0.000
August trajectories - 50 m grid cells												
Long-tailed Duck	37792	12999	13281	7365	2062	22	4	0.351	0.195	0.055	0.001	0.000
Glaucous Gull	1730	316	498	229	72	6	1	0.288	0.132	0.042	0.003	0.001
King Eider	6698	4732	152	25	8	0	0	0.023	0.004	0.001	0.000	0.000
Common Eider	1477	1092	1272	555	125	0	0	0.861	0.376	0.085	0.000	0.000
Spectacled Eider	30	30	0	0	0	0	0	0.000	0.000	0.000	0.000	0.000
Pacific Loon	666	146	82	26	9	0	0	0.123	0.039	0.014	0.000	0.000
Red-throated Loon	169	57	16	6	2	0	0	0.095	0.036	0.014	0.000	0.000
Yellow-billed Loon	17	12	0	0	0	0	0	0.000	0.000	0.000	0.000	0.000
Scoter species	3494	1927	270	97	22	0	0	0.077	0.028	0.006	0.000	0.000
August trajectories - 25 m grid cells												
Long-tailed Duck	37792	12999	9447	6442	1710	20	3	0.250	0.170	0.045	0.001	0.000
Glaucous Gull	1730	316	382	180	59	5	1	0.221	0.104	0.034	0.003	0.001
King Eider	6698	4732	106	21	6	0	0	0.016	0.003	0.001	0.000	0.000
Common Eider	1477	1092	1144	439	106	0	0	0.774	0.297	0.072	0.000	0.000
Spectacled Eider	30	30	0	0	0	0	0	0.000	0.000	0.000	0.000	0.000
Pacific Loon	666	146	57	20	8	0	0	0.086	0.030	0.011	0.000	0.000
Red-throated Loon	169	57	13	4	2	0	0	0.077	0.024	0.011	0.000	0.000
Yellow-billed Loon	17	12	0	0	0	0	0	0.000	0.000	0.000	0.000	0.000
Scoter species	3494	1927	194	69	17	0	0	0.056	0.020	0.005	0.000	0.000

Table 6. Number of birds estimated at 90% low, mean, and 90% high confidence intervals that were exposed to oil as for various quantiles of the 500 modeled trajectories of a 5,912-barrel oil spill in July at the Liberty project site.

Quantile	species	lo90%ci	mean	hi90%ci		lo90%ci	mean	hi90%ci		lo90%ci	mean	hi90%ci
0.01	Long-tailed Duck	2	30	59	Common Eider	1	2	3	Red-throated Loon	0	0	0
0.1		4	84	168		2	5	7		0	0	1
0.2		7	138	282		4	10	18		0	1	2
0.3		12	182	356		8	21	32		0	2	4
0.4		29	467	938		13	35	64		0	3	7
median 0.5		61	1072	2135		26	74	117		0	5	13
0.6		93	1562	3126		64	146	272		1	9	19
0.7		125	2093	4270		91	241	415		1	11	26
0.8		162	2519	5121		122	357	629		2	14	34
0.9		209	3667	7744		154	425	765		3	21	48
0.99	354	6123	12807	189	601	1075	4	31	69			
0.01	Glaucous Gull	2	5	8	Spectacled Eider	0	0	0	Yellow-billed Loon	0	0	0
0.1		3	10	16		0	0	0		0	0	0
0.2		8	27	45		0	0	0		0	0	1
0.3		15	64	113		0	0	0		0	0	1
0.4		26	143	257		0	0	0		0	1	2
median 0.5		43	193	342		0	0	0		0	2	4
0.6		53	230	413		0	0	0		0	3	8
0.7		71	287	505		0	0	0		0	4	12
0.8		87	367	669		0	0	0		0	6	15
0.9		119	487	870		0	2	10		0	8	20
0.99	173	726	1282	0	35	94	0	13	31			
0.01	King Eider	0	0	1	Pacific Loon	0	0	0	Scoter species	0	3	5
0.1		0	1	2		0	1	1		1	5	10
0.2		0	1	3		1	1	2		2	10	19
0.3		0	3	7		1	2	3		3	19	34
0.4		0	6	15		2	4	6		5	39	73
median 0.5		0	14	35		4	8	13		10	66	124
0.6		1	37	91		8	23	40		21	175	342
0.7		10	213	505		11	32	58		27	230	453
0.8		19	367	926		15	45	77		35	275	523
0.9		34	679	1746		19	62	105		48	342	657
0.99	112	2062	4977	29	110	193	63	616	1351			

Table 7. Number of birds estimated at 90% low, mean, and 90% high confidence intervals that were exposed to oil as for various quantiles of the 500 modeled trajectories of a 1,580-barrel oil spill in July at the Liberty project site.

Quantile	species	lo90%ci	mean	hi90%ci		lo90%ci	mean	hi90%ci		lo90%ci	mean	hi90%ci
0.01	Long-tailed Duck	2	28	54	Common Eider	1	2	3	Red-throated Loon	0	0	0
0.1		4	77	152		2	5	7		0	0	1
0.2		6	122	245		4	9	16		0	1	2
0.3		10	162	317		7	18	28		0	2	3
0.4		25	416	827		11	29	56		0	3	6
median 0.5		54	897	1789		23	61	94		0	4	11
0.6		74	1282	2542		49	114	209		0	7	15
0.7		99	1550	3217		69	186	322		1	9	19
0.8		124	1995	3996		93	268	462		1	11	25
0.9		163	2810	5827		114	322	571		2	16	36
0.99	272	4548	9515	140	428	807	3	21	51			
0.01	Glaucous Gull	1	4	7	Spectacled Eider	0	0	0	Yellow-billed Loon	0	0	0
0.1		3	9	14		0	0	0		0	0	0
0.2		6	23	39		0	0	0		0	0	1
0.3		13	50	96		0	0	0		0	0	1
0.4		22	120	217		0	0	0		0	1	2
median 0.5		35	156	280		0	0	0		0	1	3
0.6		44	188	337		0	0	0		0	2	5
0.7		55	229	403		0	0	0		0	3	8
0.8		65	278	513		0	0	0		0	5	12
0.9		94	363	646		0	0	6		0	6	16
0.99	120	544	982	0	22	62	0	10	24			
0.01	King Eider	0	0	1	Pacific Loon	0	0	0	Scoter species	0	2	4
0.1		0	1	2		0	1	1		1	5	9
0.2		0	1	3		1	1	1		1	9	17
0.3		0	2	6		1	2	3		3	16	30
0.4		0	5	13		2	4	5		4	32	60
median 0.5		0	11	29		3	7	12		8	56	104
0.6		0	24	64		6	18	30		15	132	263
0.7		5	145	350		8	25	44		21	178	355
0.8		12	245	610		12	35	59		29	215	415
0.9		24	523	1358		15	45	77		35	264	503
0.99	85	1528	3711	23	73	136	44	405	854			

Table 8. Number of birds estimated at 90% low, mean, and 90% high confidence intervals that were exposed to oil as for various quantiles of the 500 modeled trajectories of a 5,912-barrel oil spill in August at the Liberty project site.

Quantile	species	lo90%ci	mean	hi90%ci		lo90%ci	mean	hi90%ci		lo90%ci	mean	hi90%ci
0.01	Long-tailed Duck	3	4	6	Common Eider	0	0	0	Red-throated Loon	0	0	0
0.1		13	22	28		0	0	1		0	0	0
0.2		26	39	52		0	1	3		0	0	1
0.3		50	103	151		0	2	4		0	0	2
0.4		79	287	559		0	4	10		0	1	3
median 0.5		123	703	1421		0	8	24		0	2	5
0.6		155	1069	2163		0	16	41		0	2	6
0.7		215	2093	4327		0	23	62		0	3	8
0.8		312	3833	8308		1	56	145		0	4	10
0.9		411	7365	15825		6	555	1452		0	6	15
0.99	958	11310	24384	12	1210	3176	0	15	46			
0.01	Glaucous Gull	0	1	2	Spectacled Eider	0	0	0	Yellow-billed Loon	0	0	0
0.1		0	6	12		0	0	0		0	0	0
0.2		0	9	19		0	0	0		0	0	0
0.3		1	17	36		0	0	0		0	0	0
0.4		1	25	54		0	0	0		0	0	0
median 0.5		2	34	72		0	0	0		0	0	0
0.6		4	45	98		0	0	0		0	0	0
0.7		6	58	129		0	0	0		0	0	0
0.8		9	107	221		0	0	0		0	0	0
0.9		40	229	452		0	0	0		0	0	0
0.99	83	471	981	0	0	0	0	0	0			
0.01	King Eider	0	0	0	Pacific Loon	0	0	0	Scoter species	0	0	0
0.1		0	0	0		0	0	1		0	0	0
0.2		0	0	0		0	0	1		0	0	0
0.3		0	0	0		0	1	3		0	0	0
0.4		0	0	0		0	4	9		0	0	0
median 0.5		0	0	0		0	6	15		0	0	0
0.6		0	0	0		0	7	19		0	1	4
0.7		0	6	12		0	9	24		0	7	18
0.8		0	14	30		0	15	35		0	15	40
0.9		1	25	58		9	26	50		10	97	198
0.99	17	91	210	24	53	114	24	236	464			

Table 9. Number of birds estimated at 90% low, mean, and 90% high confidence intervals that were exposed to oil as for various quantiles of the 500 modeled trajectories of a 1,580-barrel oil spill in August at the Liberty project site.

Quantile	species	lo90%ci	mean	hi90%ci		lo90%ci	mean	hi90%ci		lo90%ci	mean	hi90%ci
0.01	Long-tailed Duck	3	4	5	Common Eider	0	0	0	Red-throated Loon	0	0	0
0.1		11	20	25		0	0	1		0	0	0
0.2		22	34	45		0	1	2		0	0	1
0.3		45	94	134		0	1	4		0	0	1
0.4		70	249	493		0	3	9		0	1	3
median 0.5		107	621	1202		0	7	17		0	1	4
0.6		128	866	1689		0	13	34		0	2	6
0.7		187	1734	3570		0	20	51		0	2	6
0.8		261	3313	7175		1	39	102		0	3	8
0.9		342	6442	13919		5	439	1154		0	4	12
0.99	768	8856	19062	10	1098	2876	0	10	35			
0.01	Glaucous Gull	0	1	2	Spectacled Eider	0	0	0	Yellow-billed Loon	0	0	0
0.1		0	5	10		0	0	0		0	0	0
0.2		0	8	17		0	0	0		0	0	0
0.3		0	15	32		0	0	0		0	0	0
0.4		1	22	47		0	0	0		0	0	0
median 0.5		2	30	63		0	0	0		0	0	0
0.6		3	37	84		0	0	0		0	0	0
0.7		5	49	107		0	0	0		0	0	0
0.8		7	89	181		0	0	0		0	0	0
0.9		28	180	368		0	0	0		0	0	0
0.99	65	360	753	0	0	0	0	0	0			
0.01	King Eider	0	0	0	Pacific Loon	0	0	0	Scoter species	0	0	0
0.1		0	0	0		0	0	1		0	0	0
0.2		0	0	0		0	0	1		0	0	0
0.3		0	0	0		0	1	2		0	0	0
0.4		0	0	0		0	3	8		0	0	0
median 0.5		0	0	0		0	5	12		0	0	0
0.6		0	0	0		0	6	16		0	1	3
0.7		0	5	10		0	8	21		0	6	15
0.8		0	10	22		0	13	29		0	12	32
0.9		1	21	45		6	20	42		6	69	146
0.99	9	65	151	19	41	83	19	171	335			

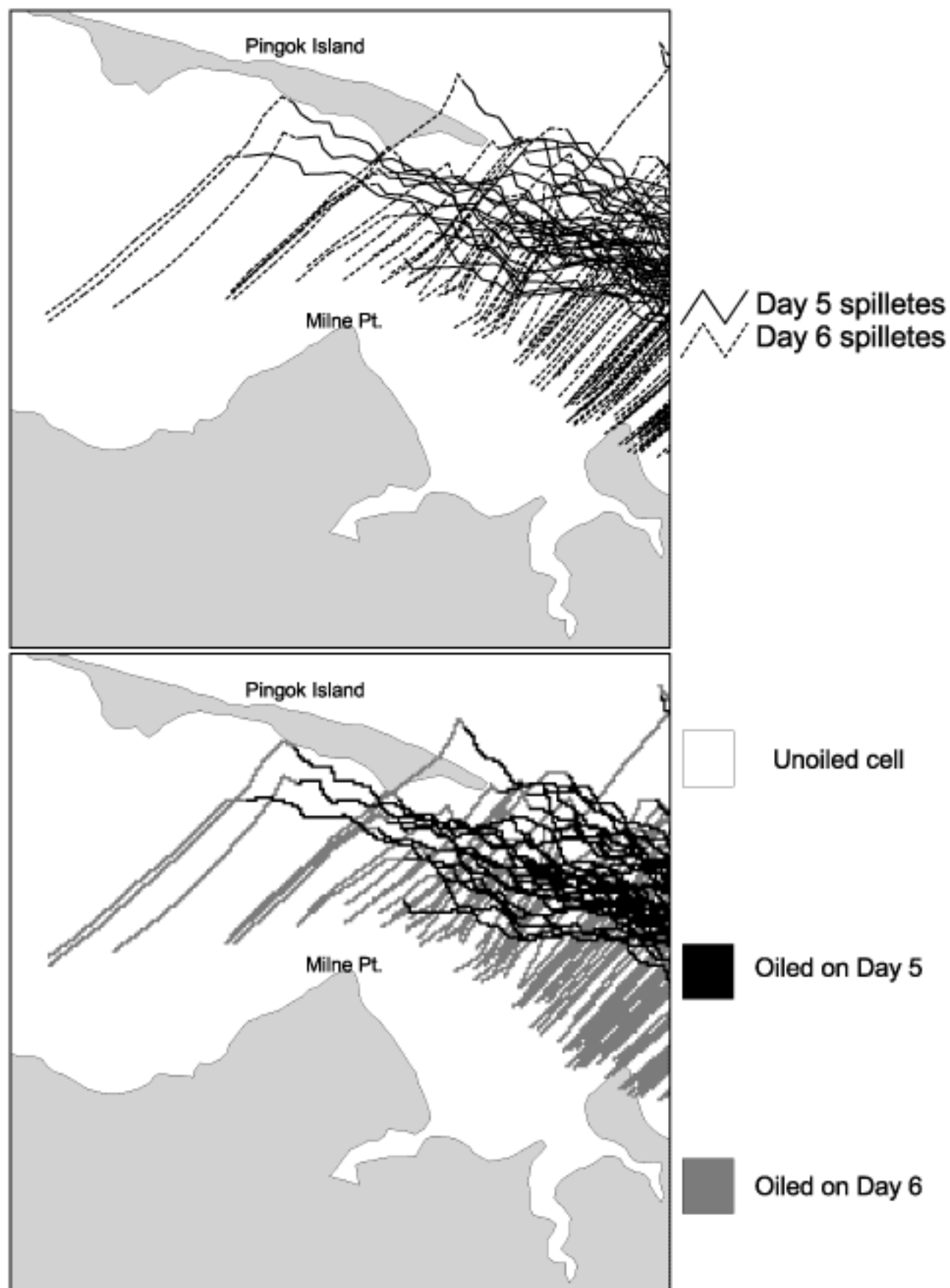

Fig. 1. Example of vector to raster conversion of a portion of spilletes from days 5 and 6 of 1 spill using a 50 meter cell size. If a cell contained spilletes from more than 1 day, the lowest day value was assigned to the cell.

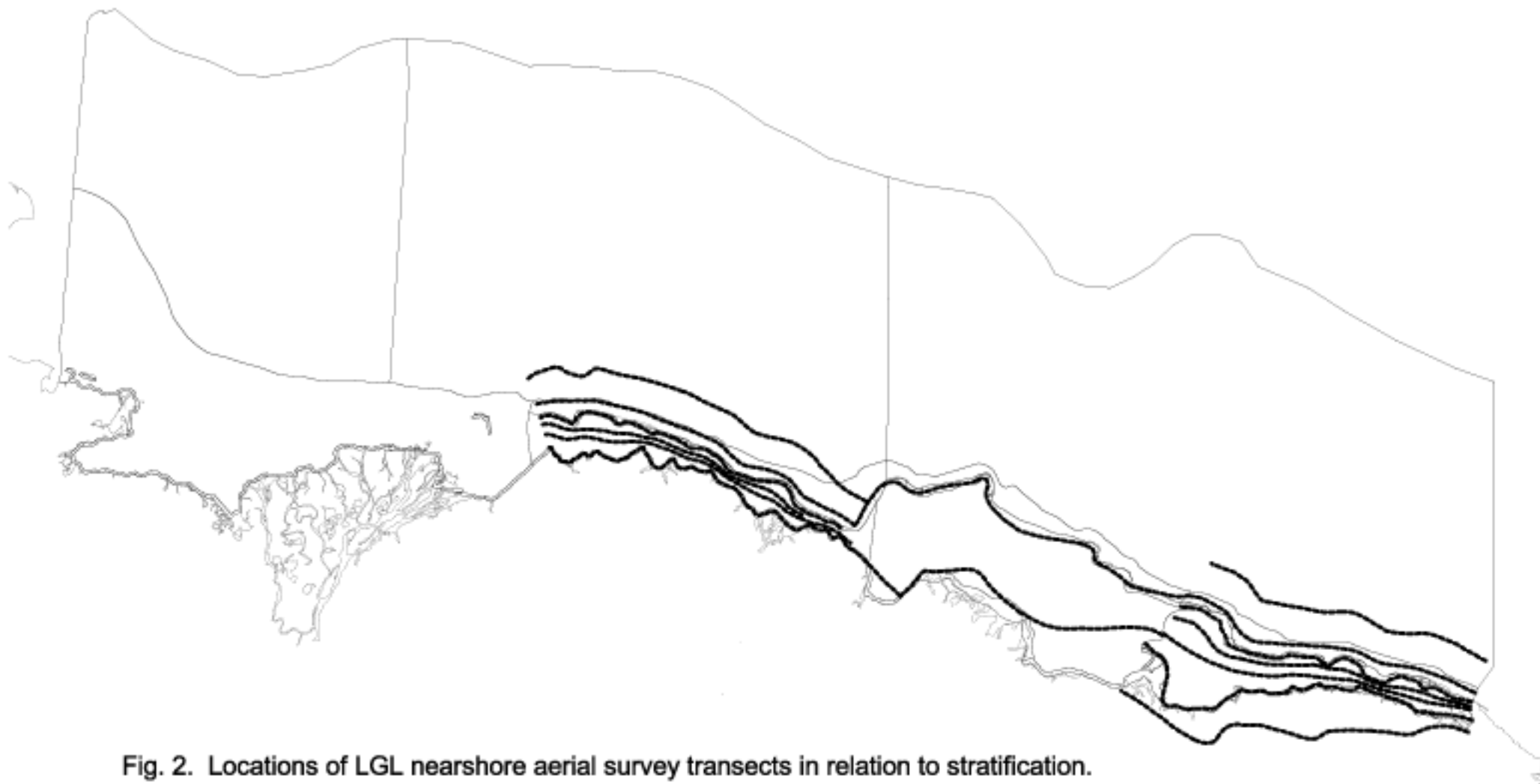

Fig. 2. Locations of LGL nearshore aerial survey transects in relation to stratification.

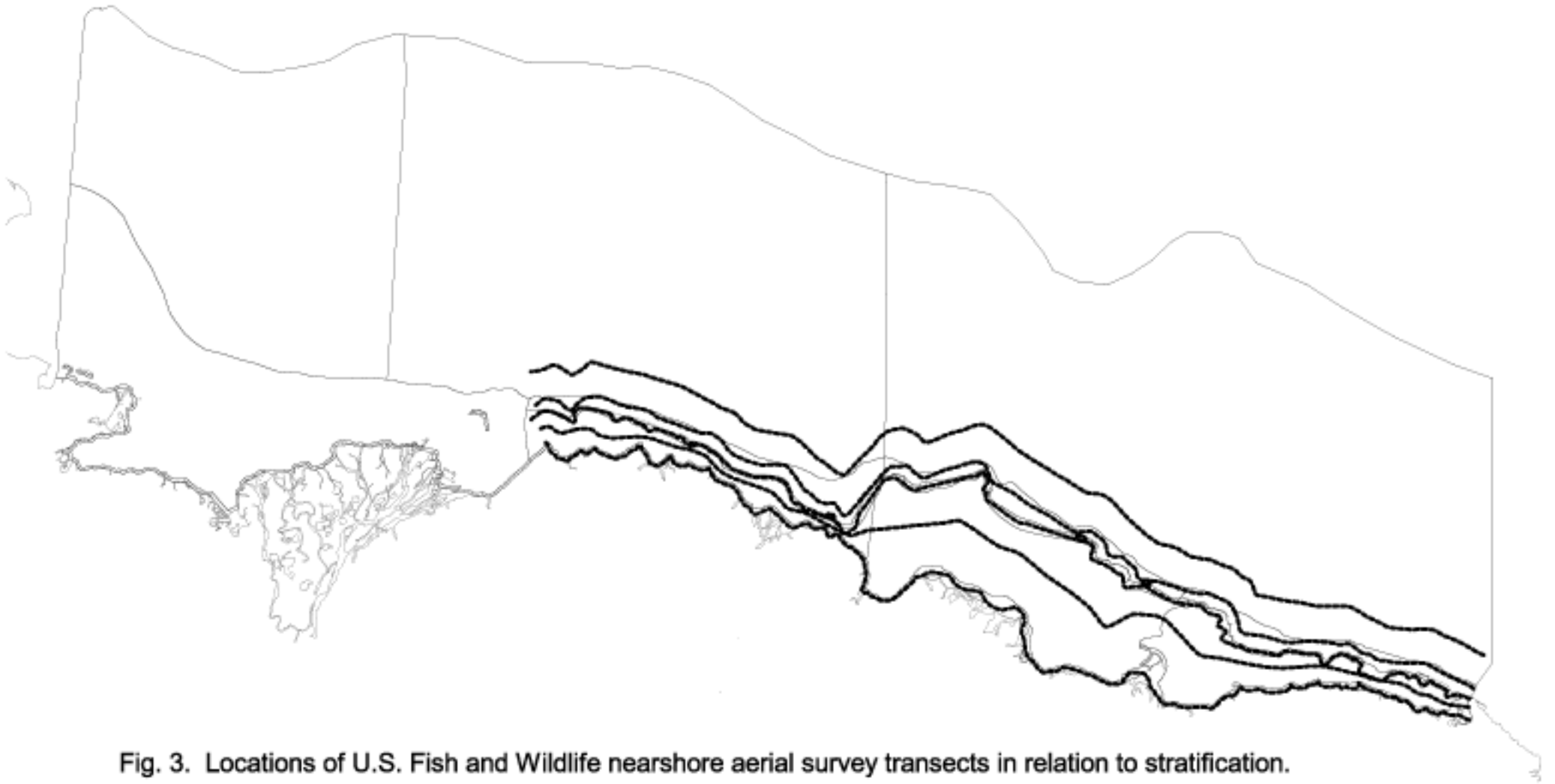

Fig. 3. Locations of U.S. Fish and Wildlife nearshore aerial survey transects in relation to stratification.

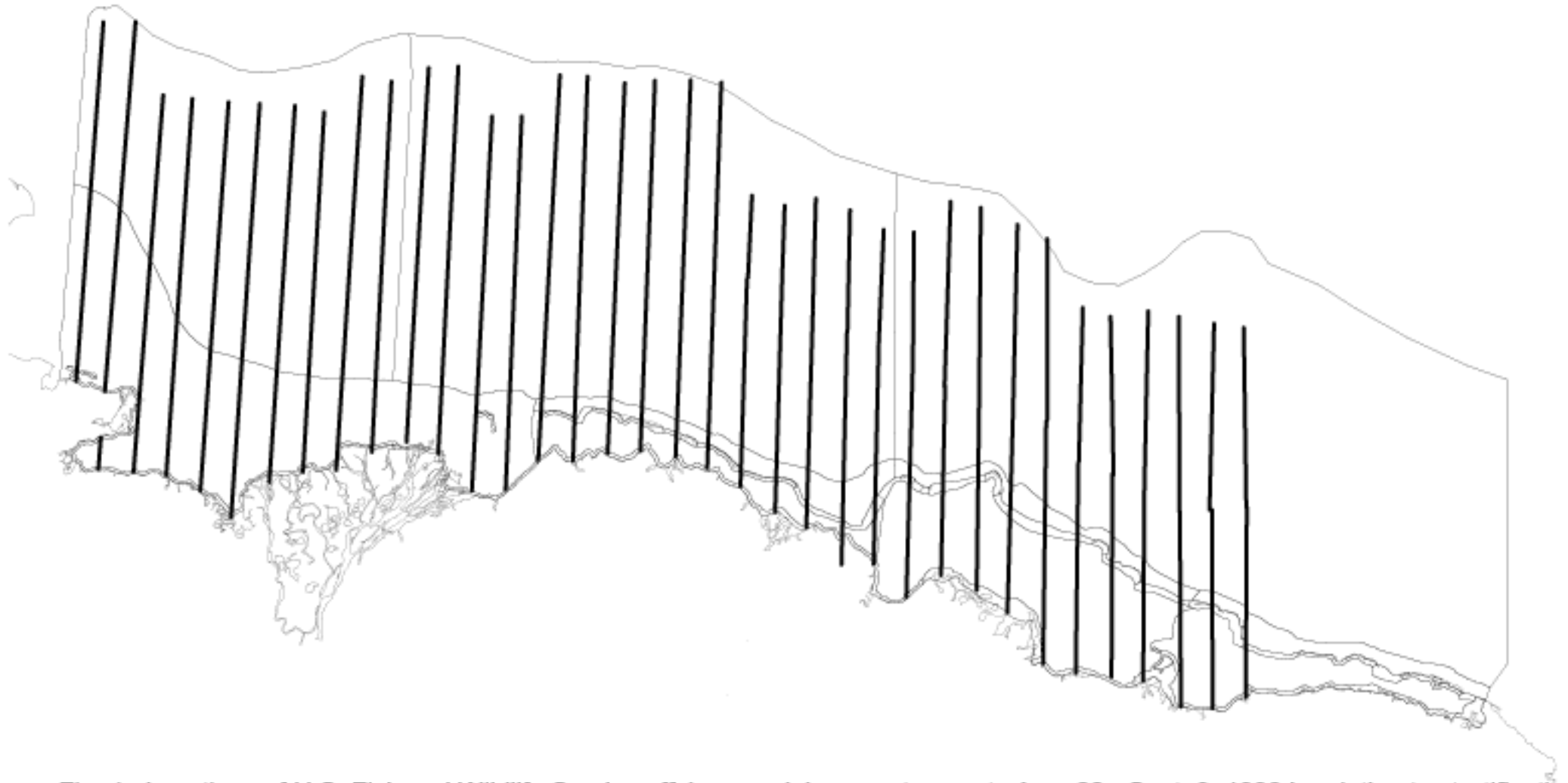

Fig. 4. Locations of U.S. Fish and Wildlife Service offshore aerial survey transects Aug. 28 - Sept. 3, 1999 in relation to stratification.



Projection : UTM Zone 6, NAD 27

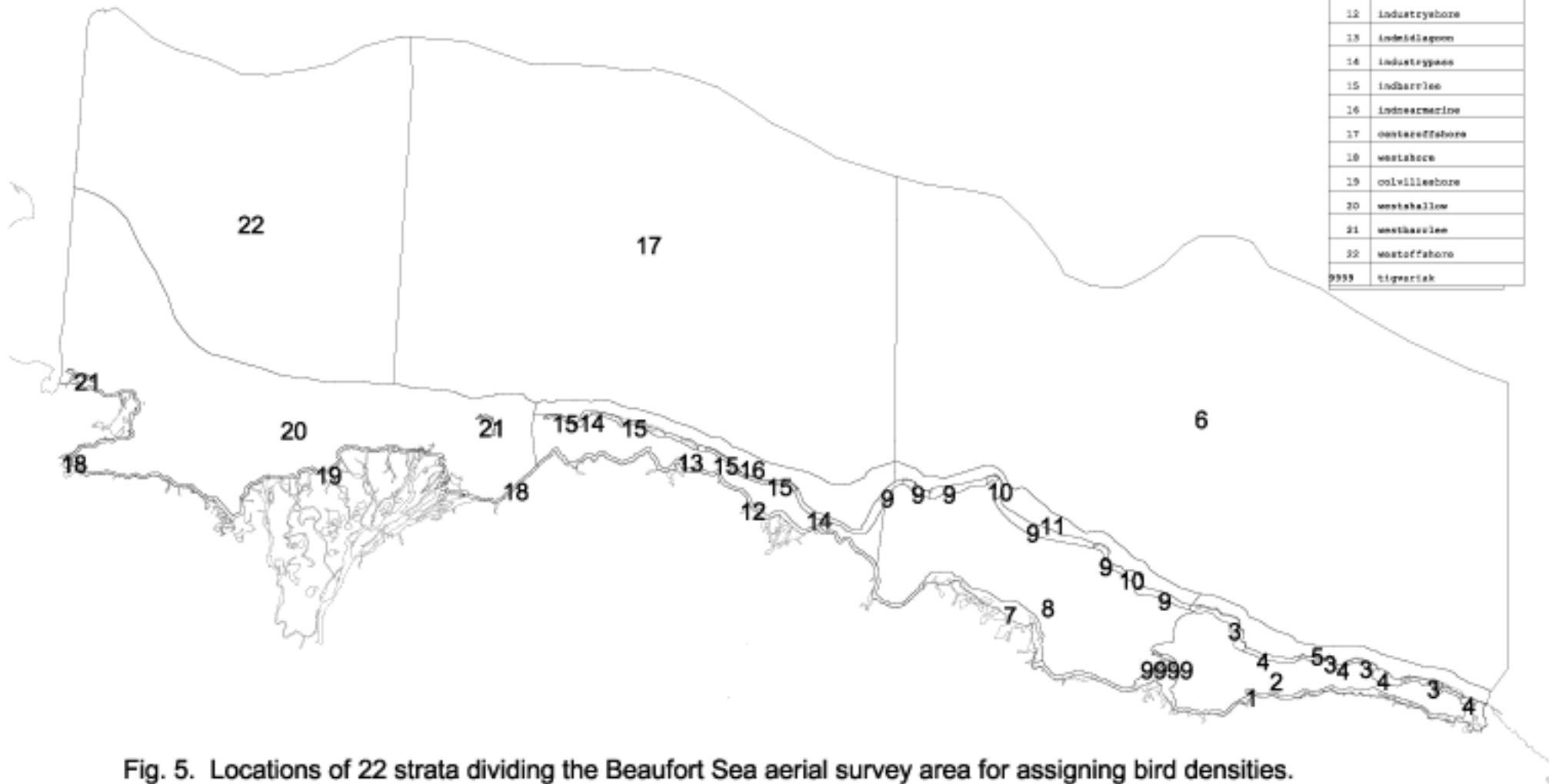

Fig. 5. Locations of 22 strata dividing the Beaufort Sea aerial survey area for assigning bird densities.

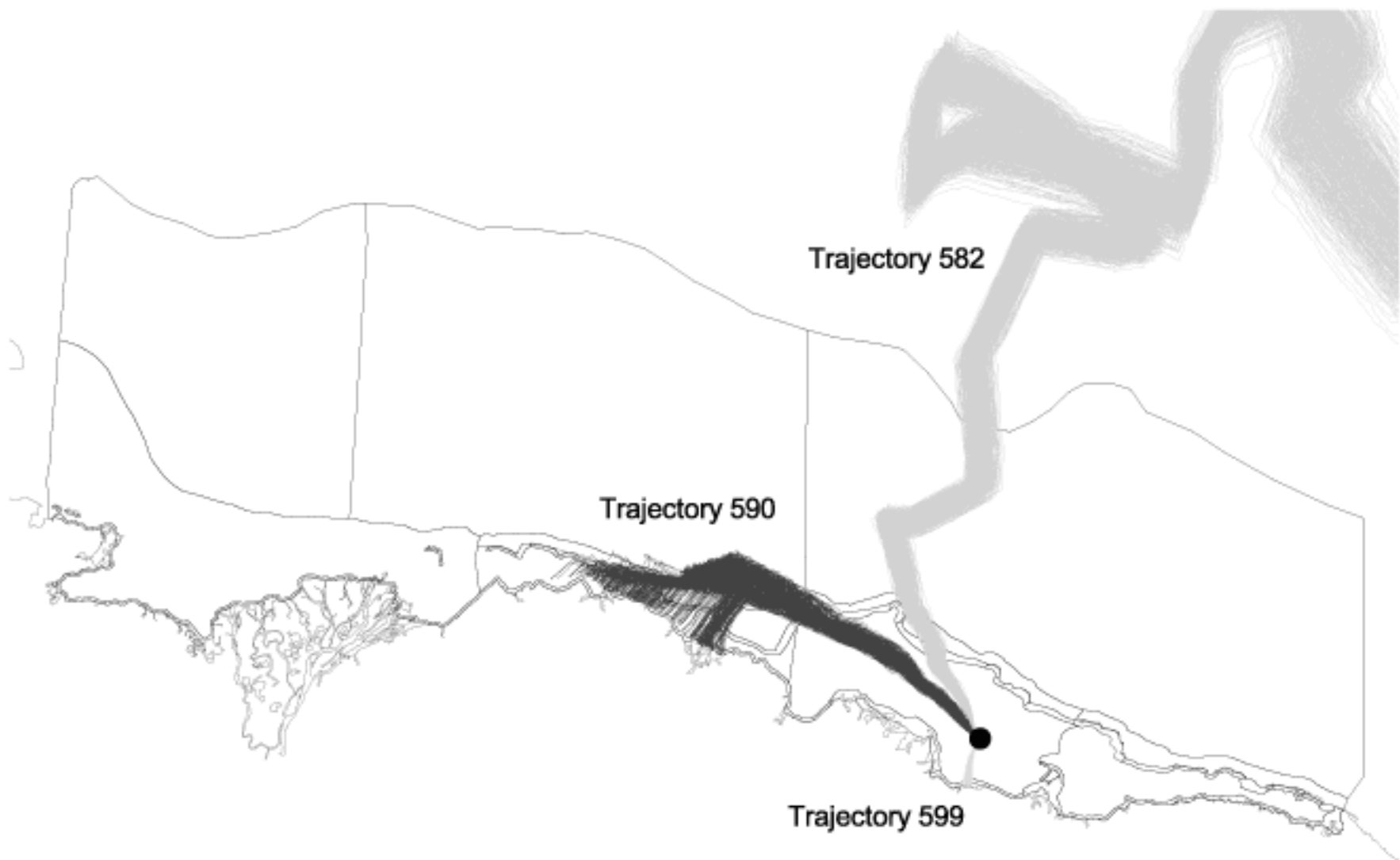

Fig. 6 Three simulated August oil spill trajectories overlaying the bird density stratification.

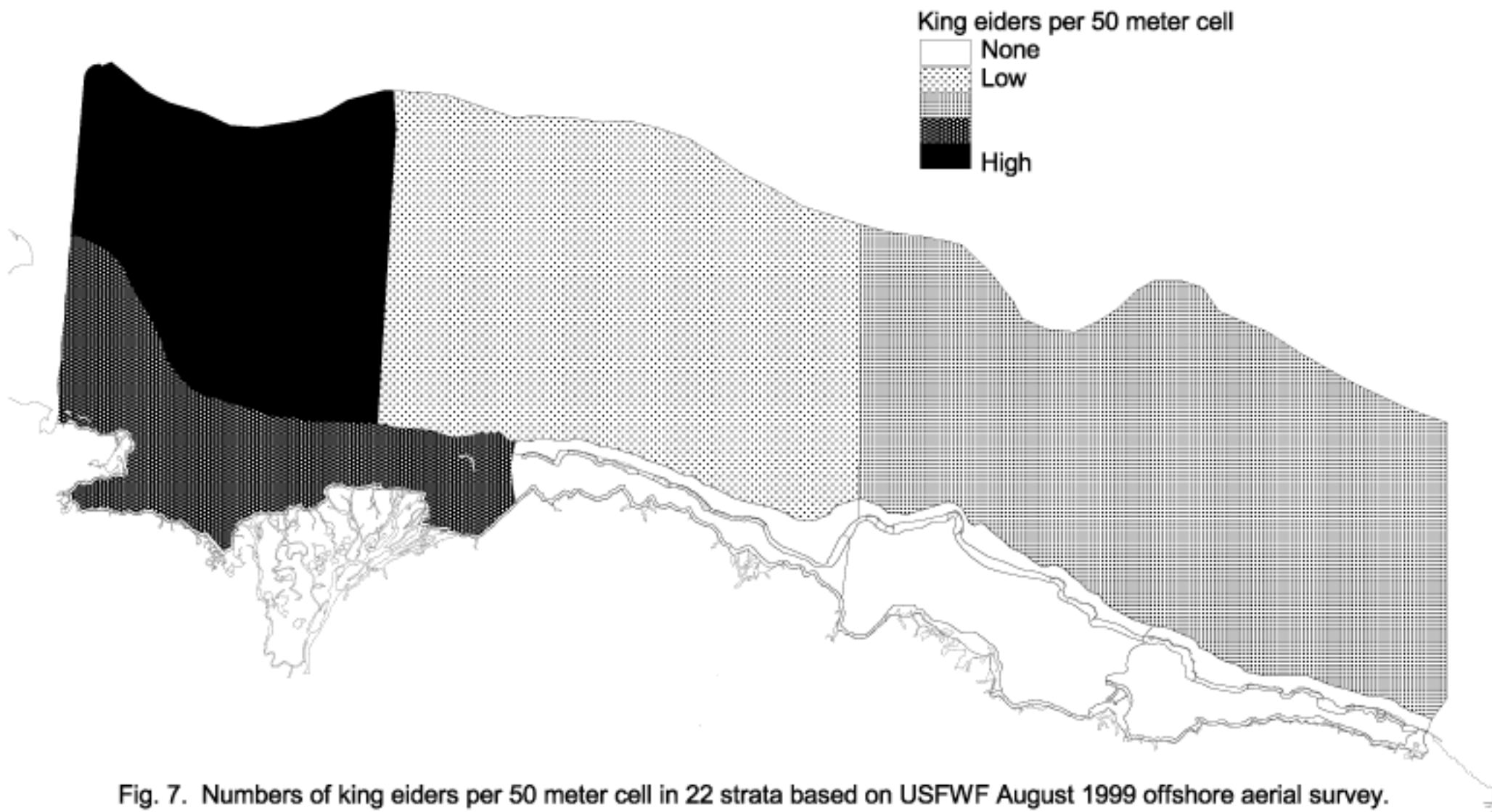

Fig. 7. Numbers of king eiders per 50 meter cell in 22 strata based on USFWS August 1999 offshore aerial survey.

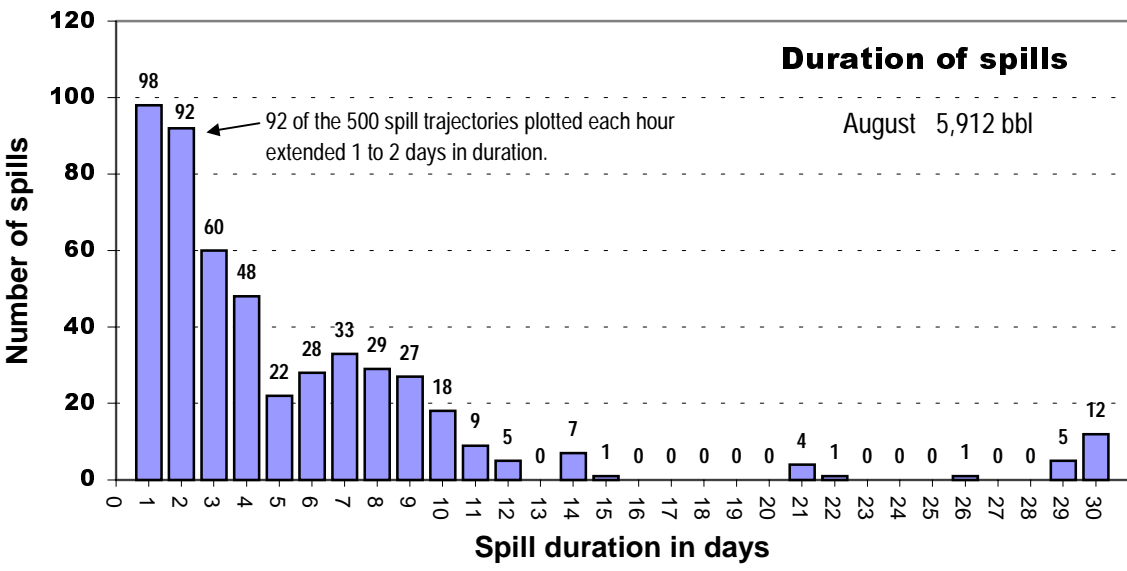
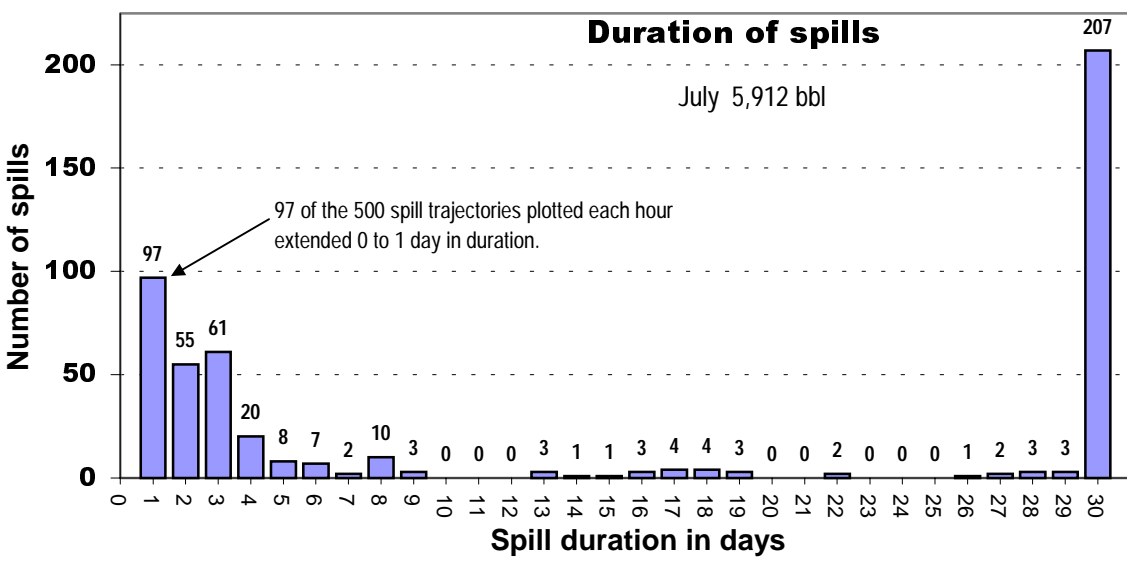

Figure 8. Frequency distribution of the duration in days of 500 July or 500 August oil spill trajectories within the aerial surveyed bird density area.

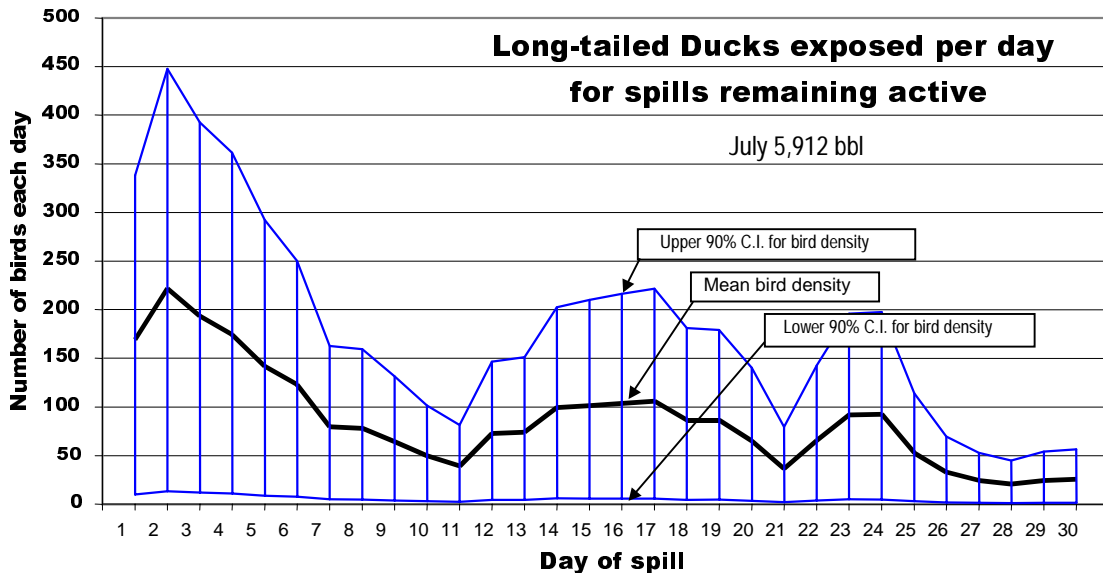
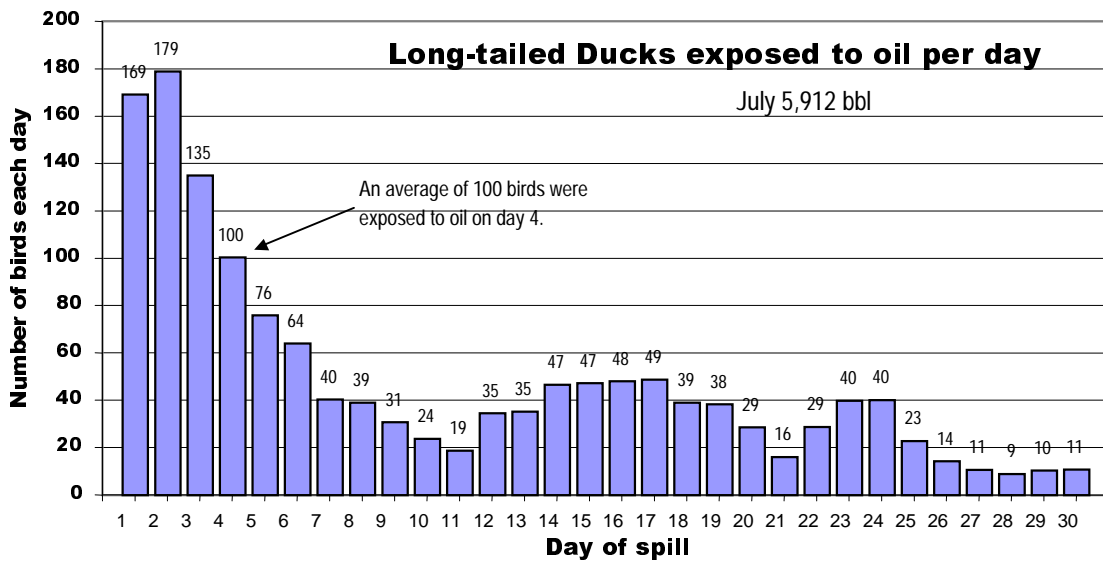
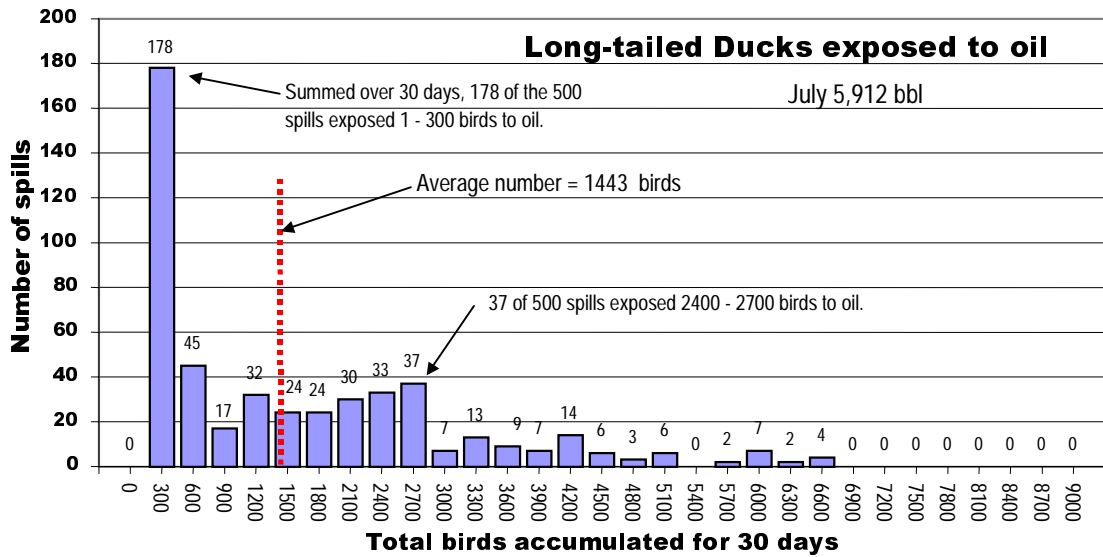

Figure 9. Number of long-tailed ducks exposed in 500 trajectories of 5912-barrel spills in July.

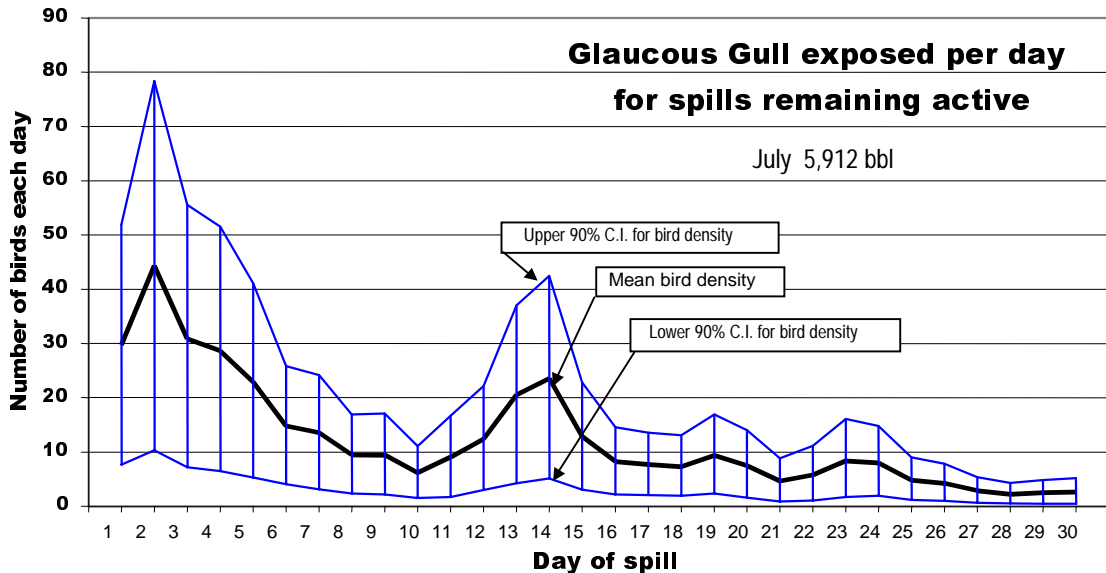
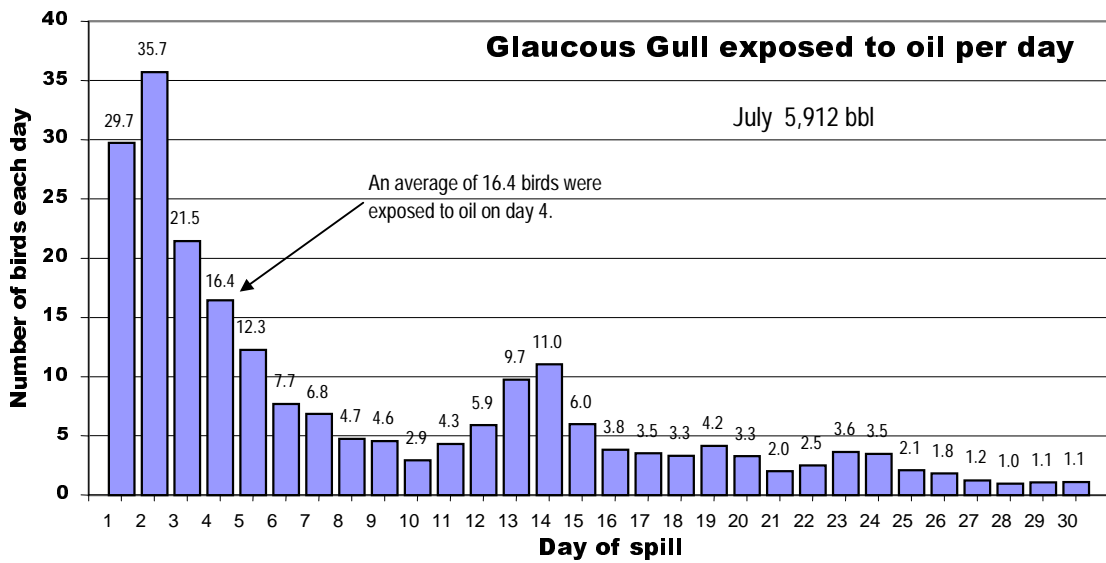
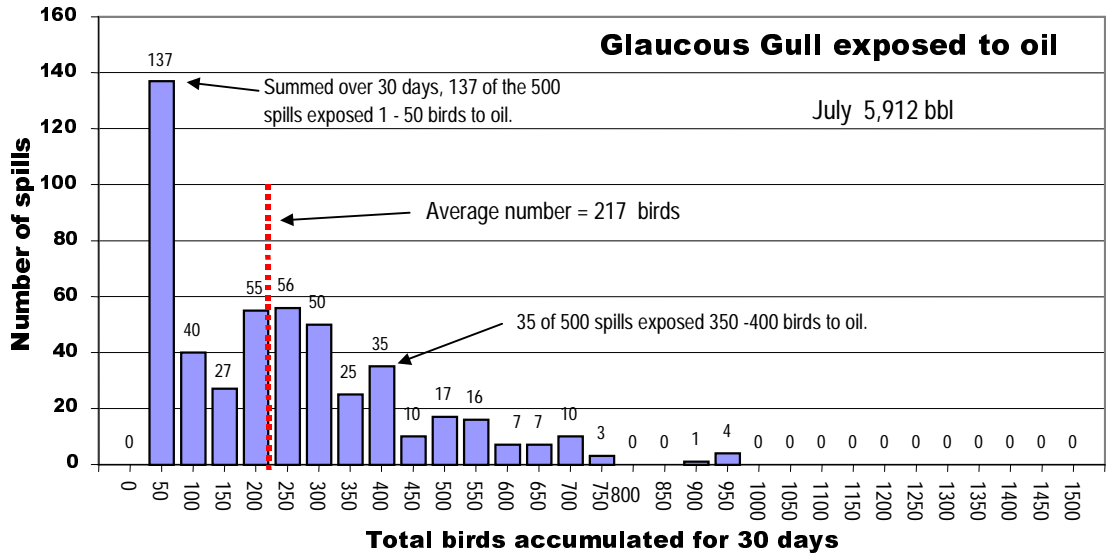

Figure 10. Number of glaucous gull exposed in 500 trajectories of 5912-barrel spills in July.

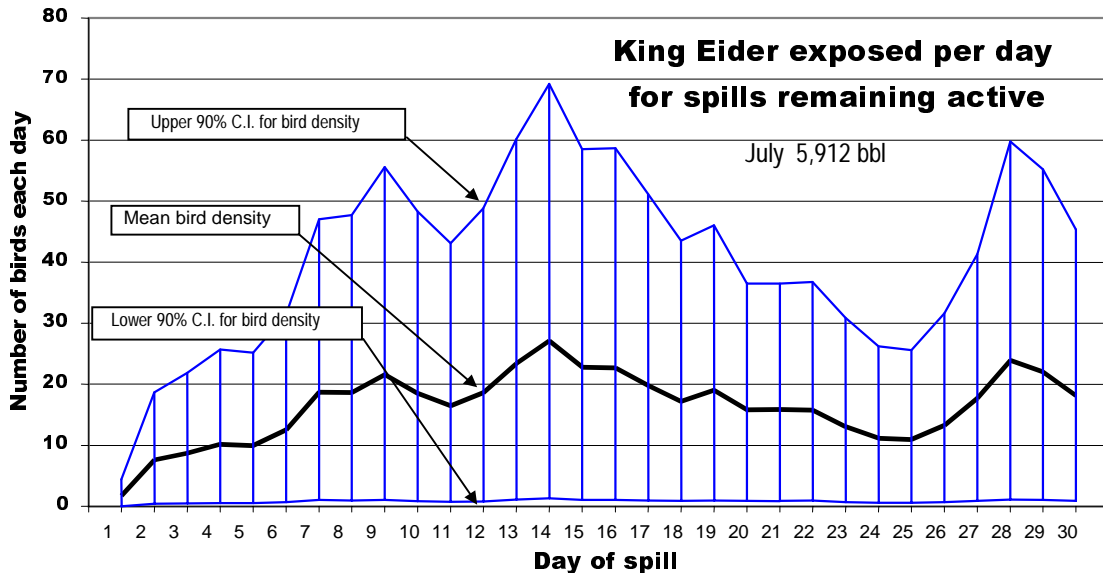
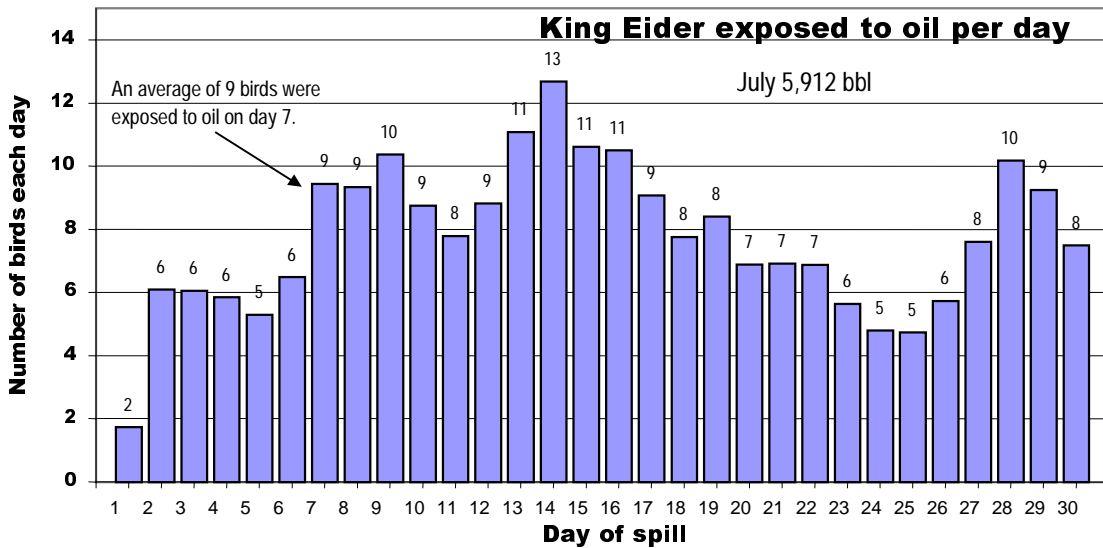
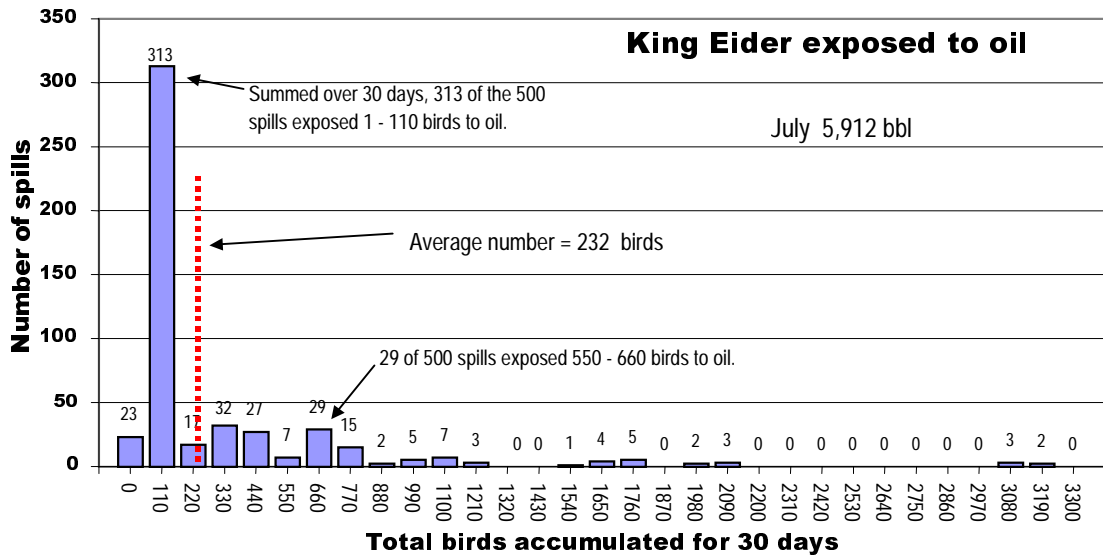

Figure 11. Number of king eider exposed in 500 trajectories of 5912-barrel spills in July.

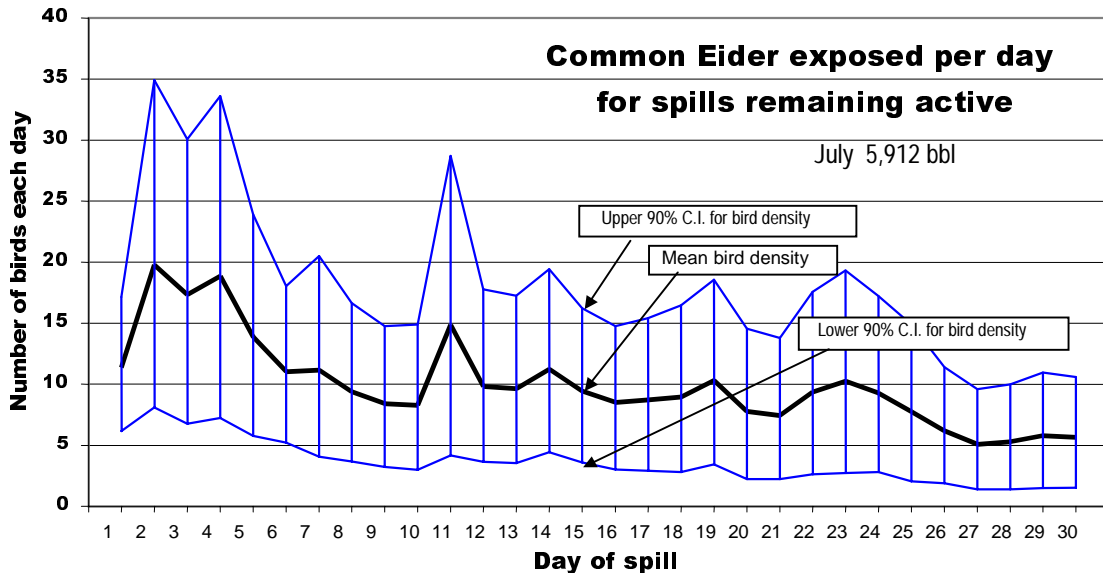
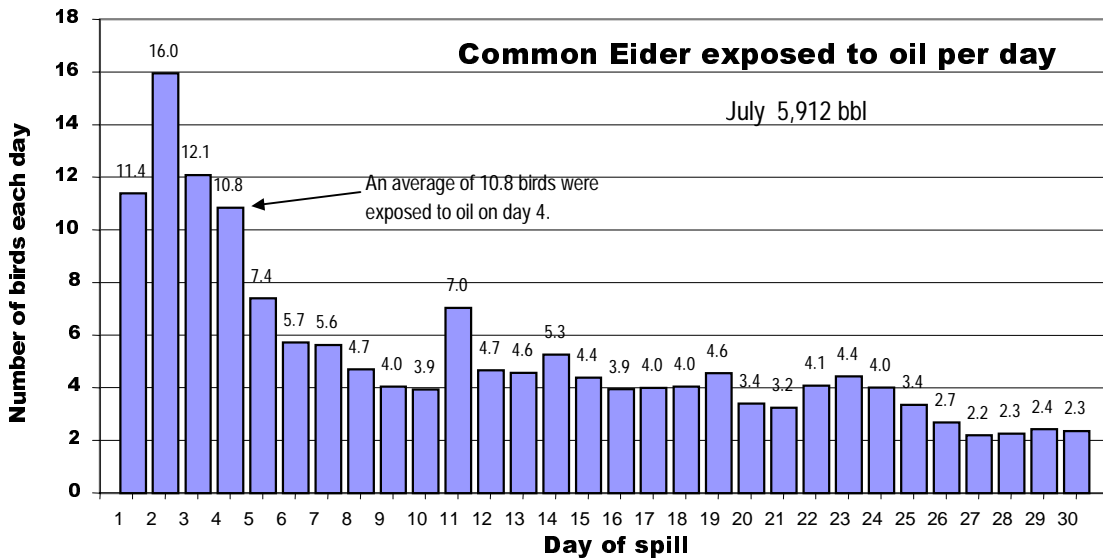
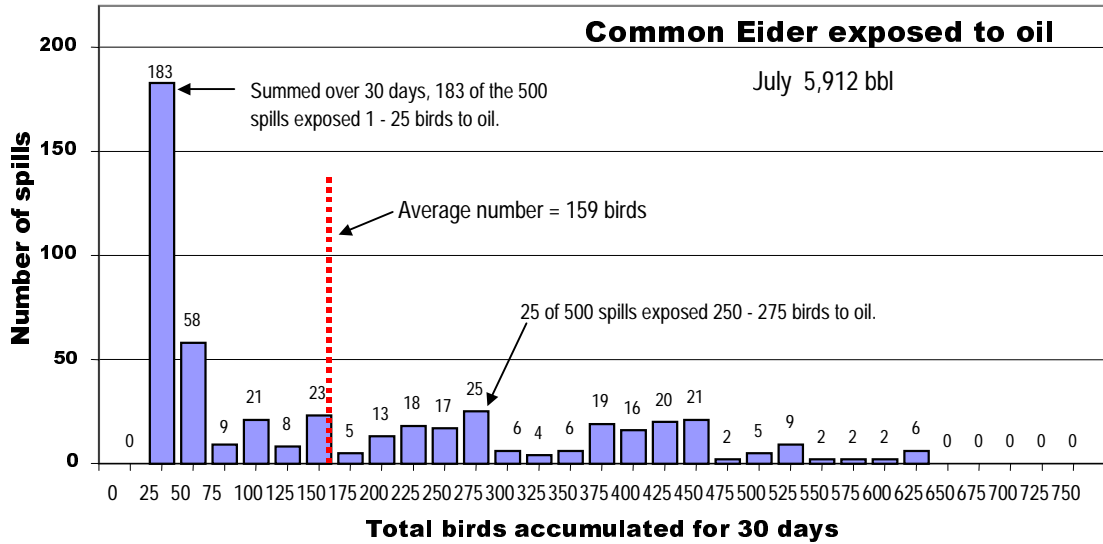

Figure 12. Number of common eider exposed in 500 trajectories of 5912-barrel spills in July.

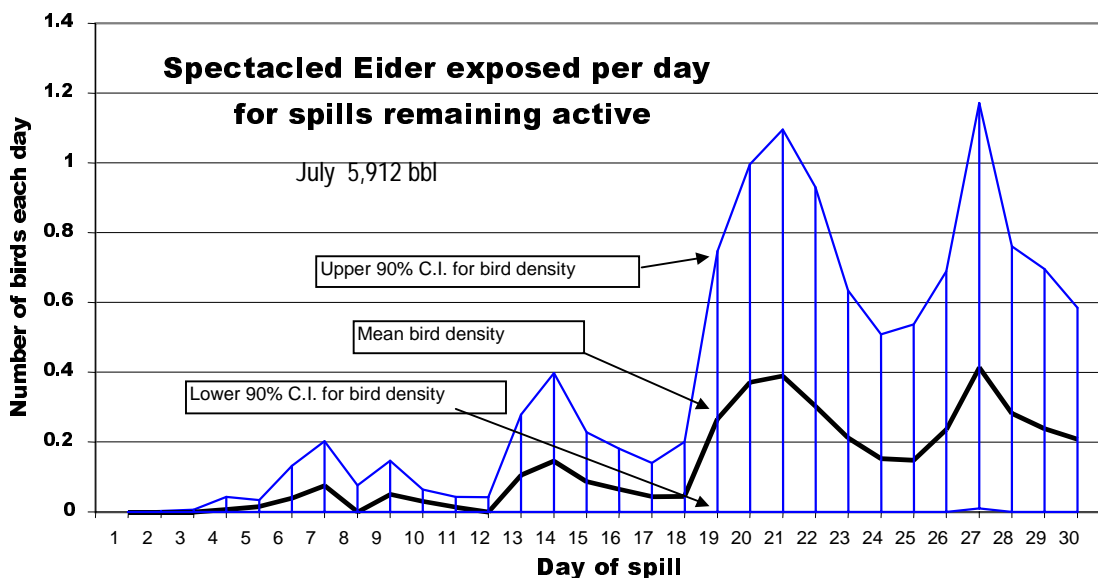
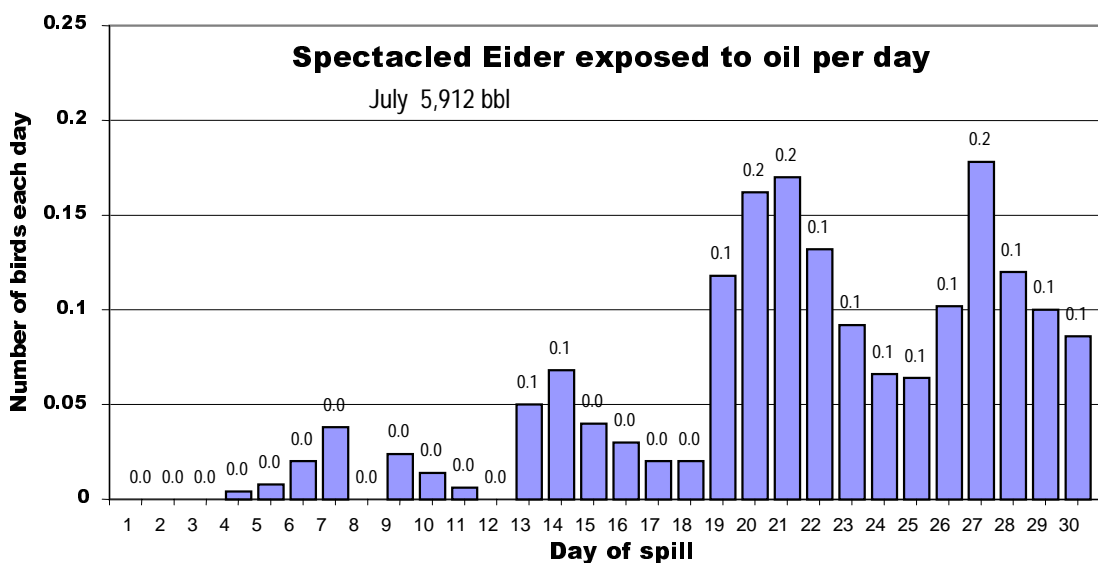
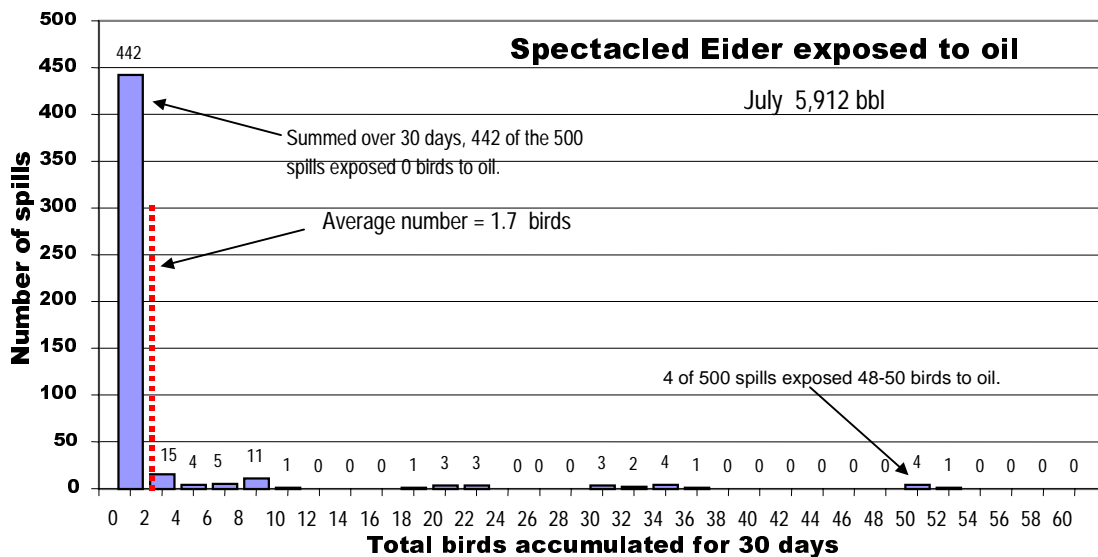

Figure 13. Number of spectacled eider exposed in 500 trajectories of 5912-barrel spills in July.

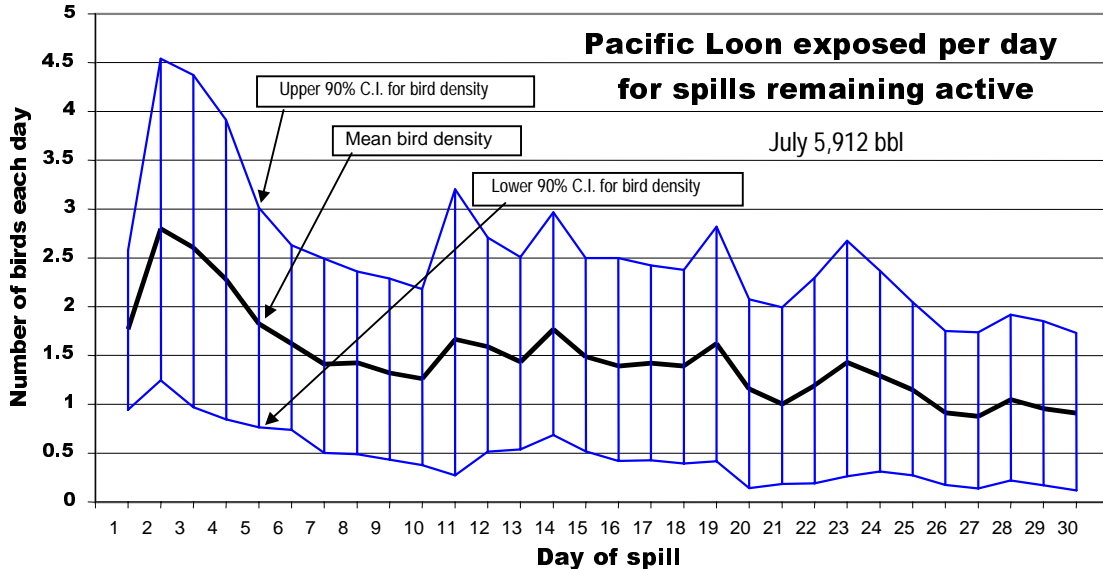
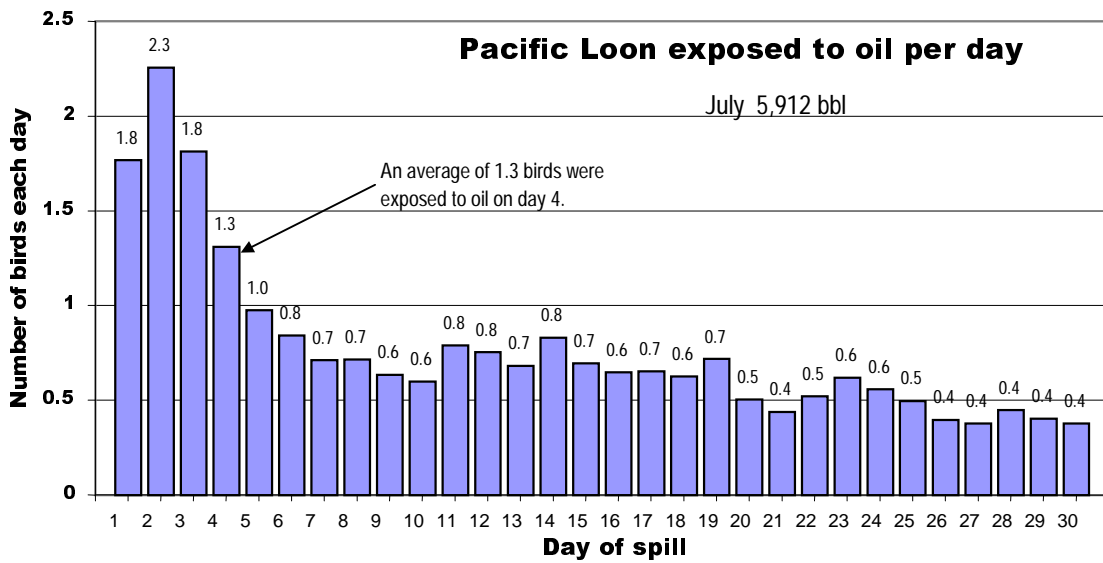
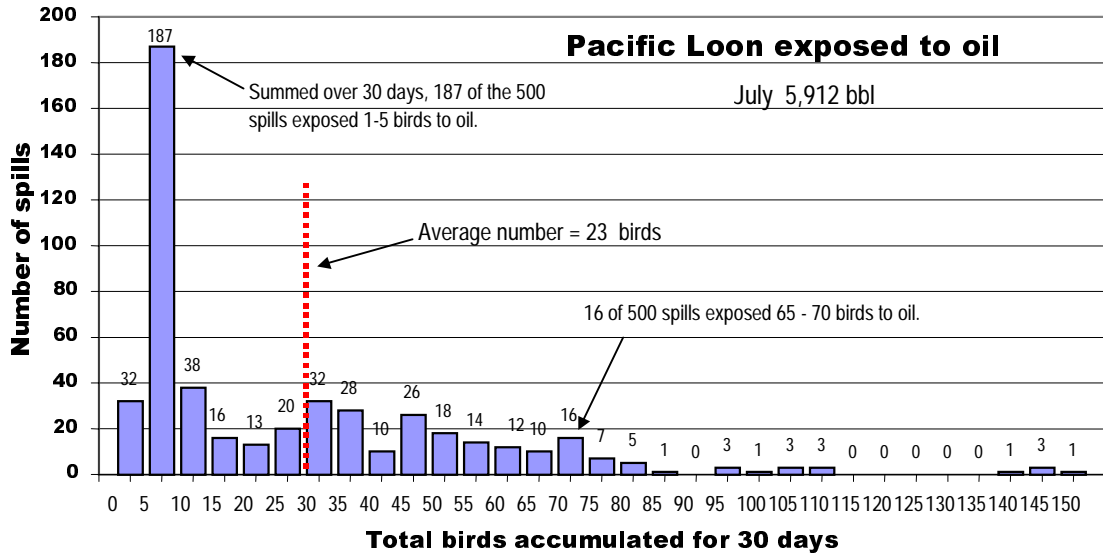

Figure 14. Number of Pacific loons exposed in 500 trajectories of 5912-barrel spills in July.

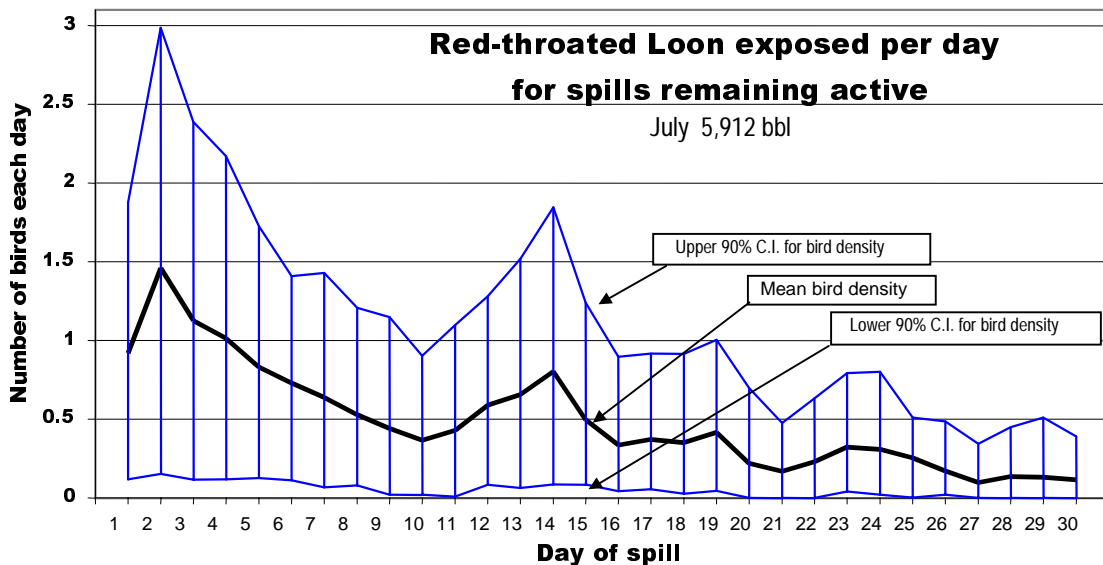
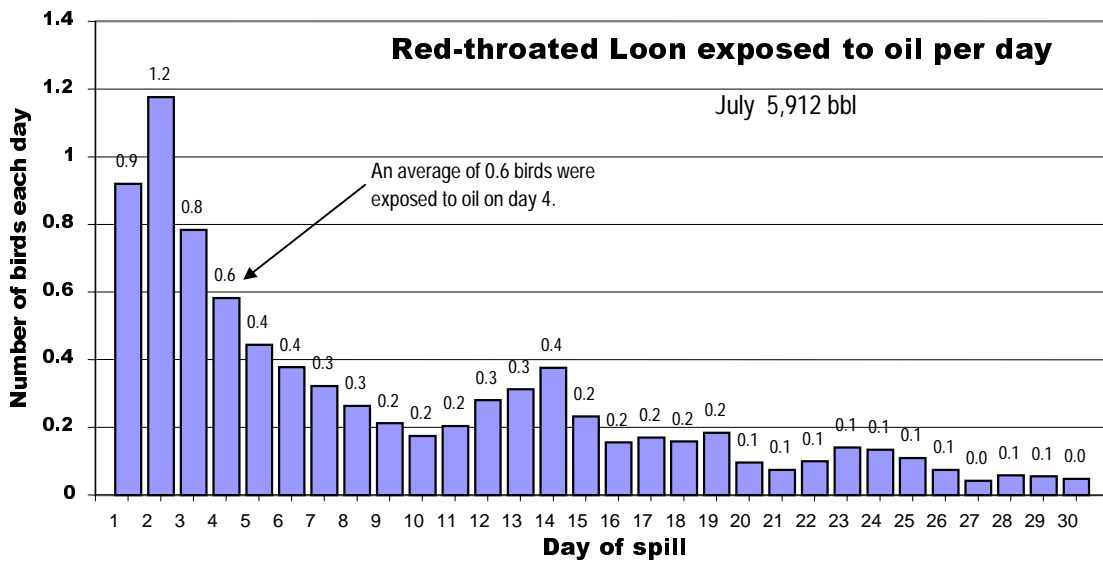
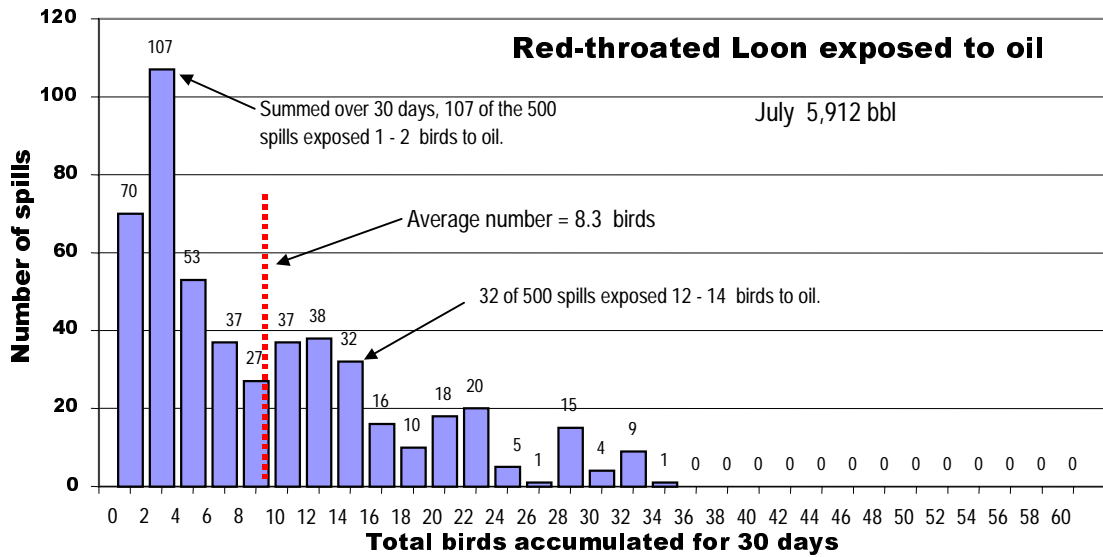

Figure 15. Number of red-throated loons exposed in 500 trajectories of 5912-barrel spills in July.

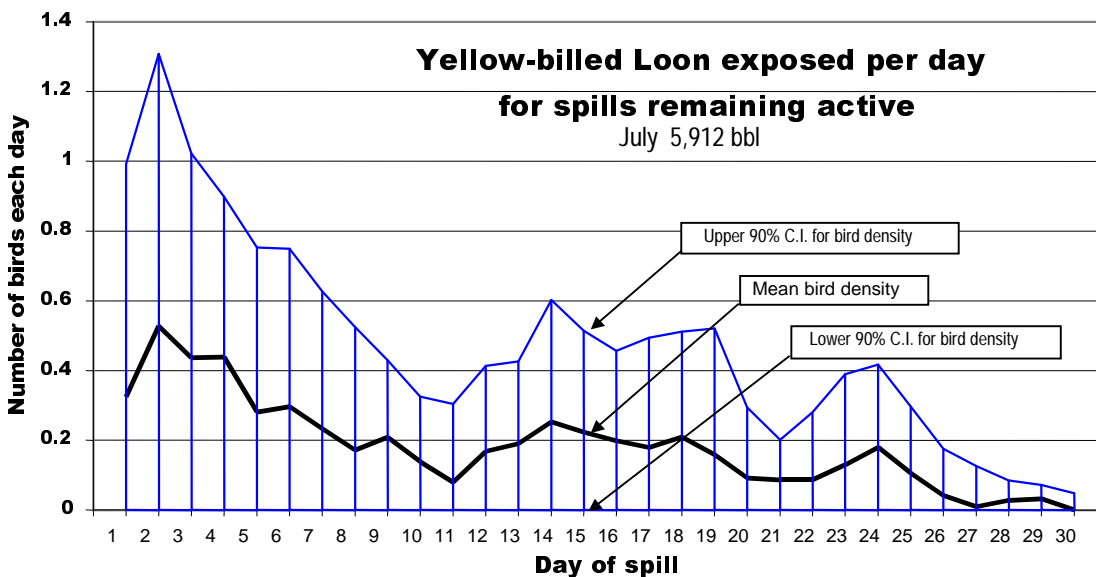
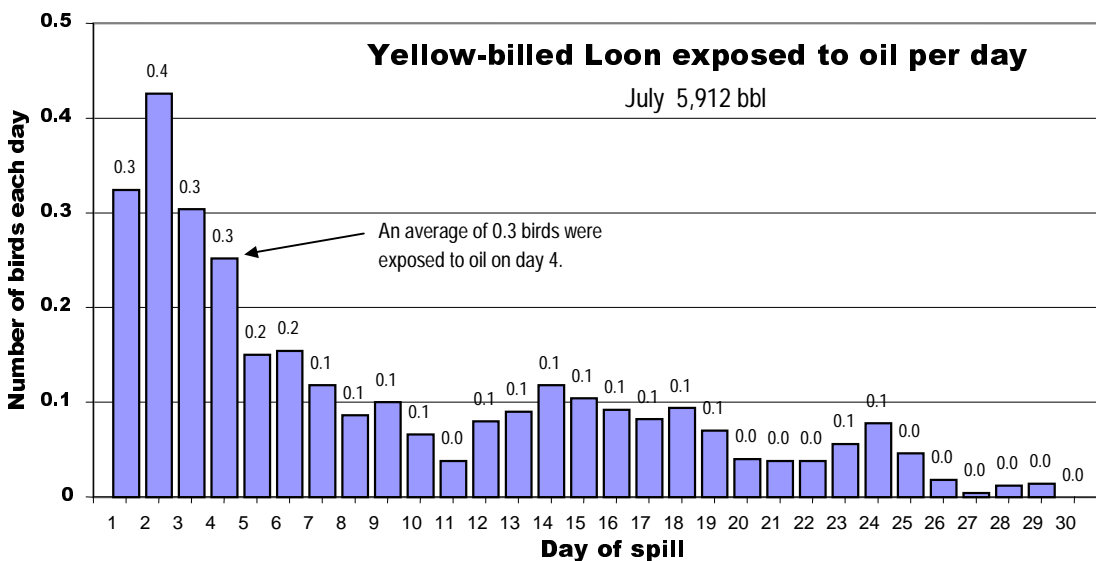
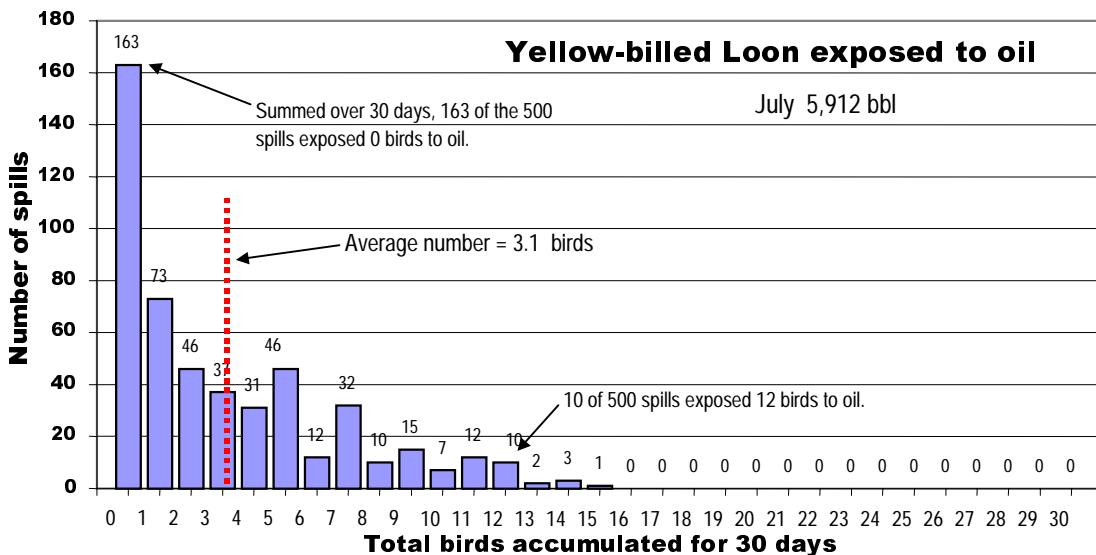

Figure 16. Number of yellow-billed loons exposed in 500 trajectories of 5912-barrel spills in July.

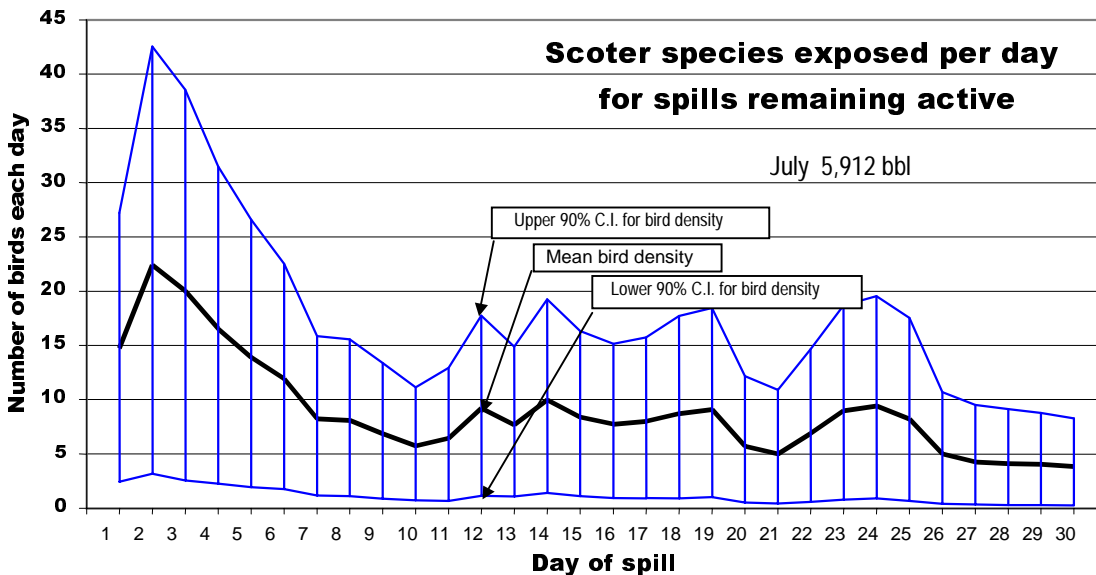
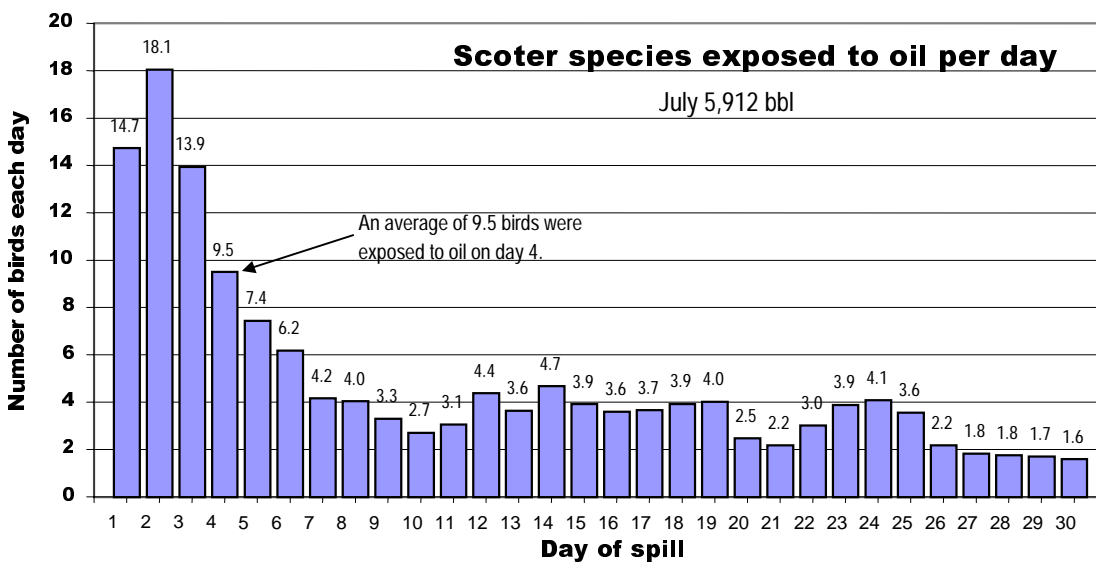
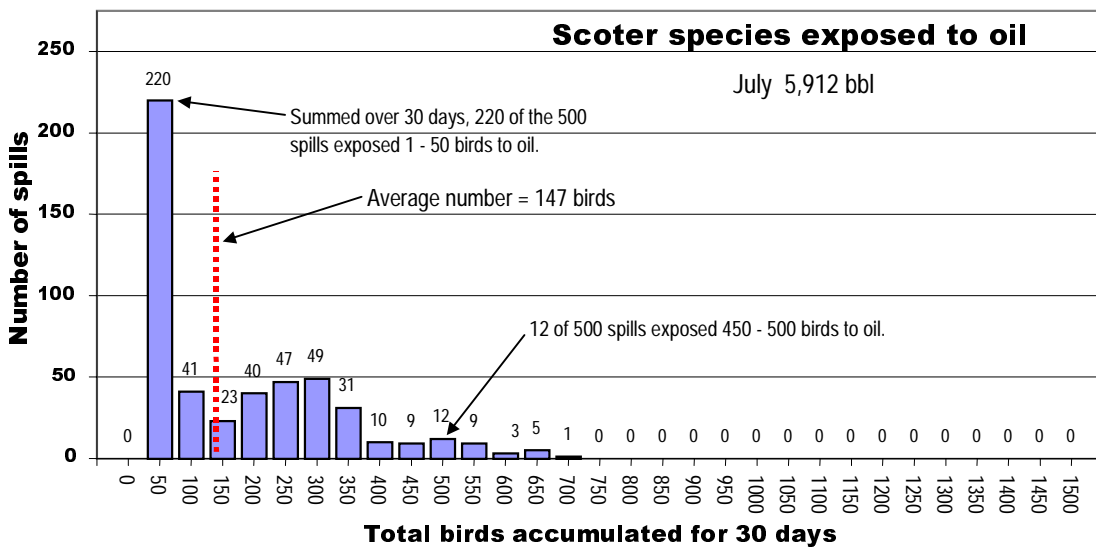

Figure 17. Number of scoters exposed in 500 trajectories of 5912-barrel spills in July.

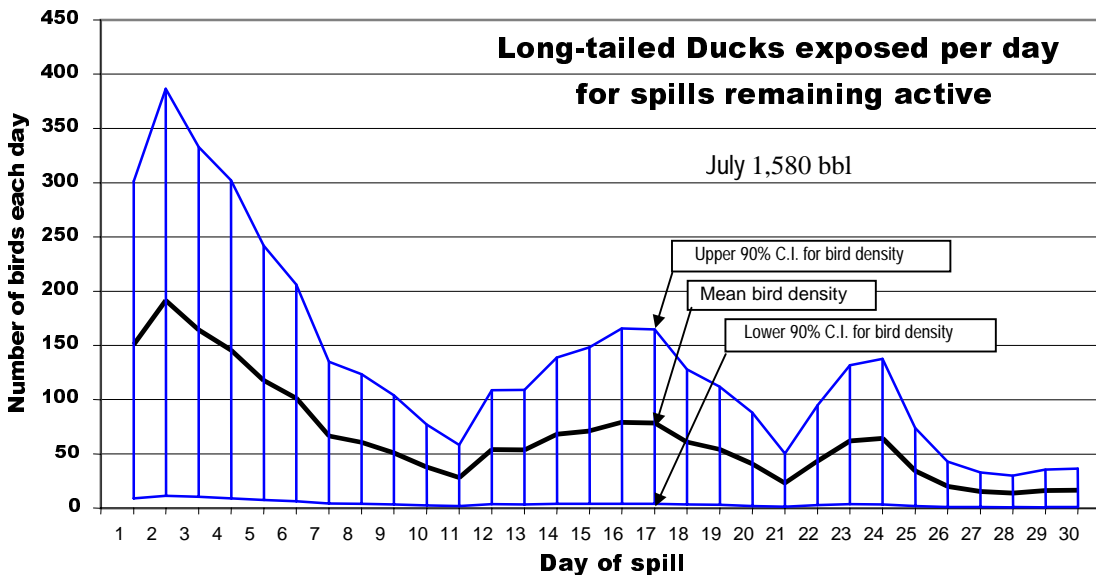
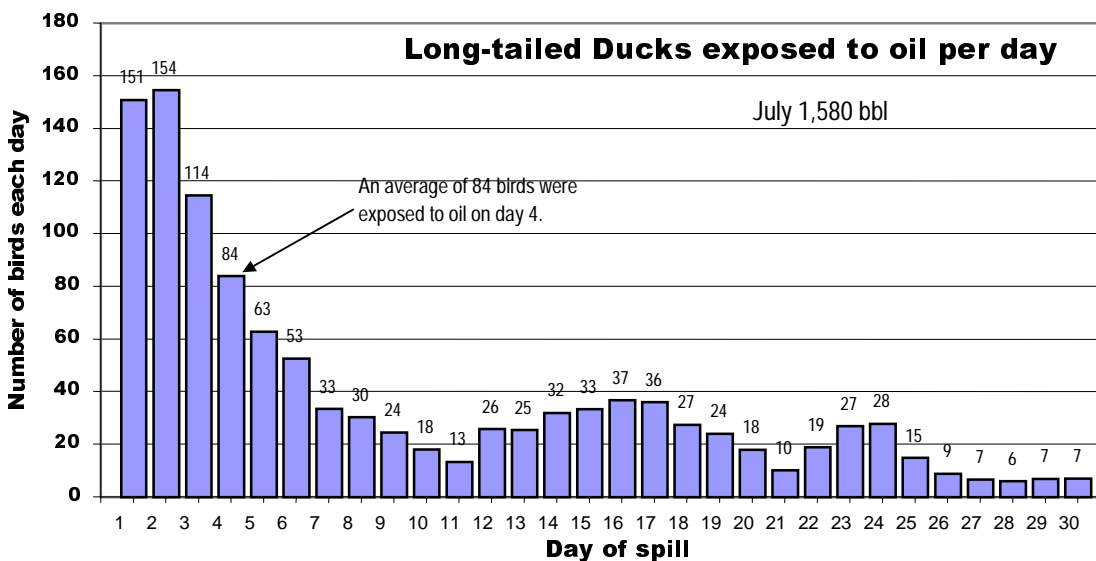
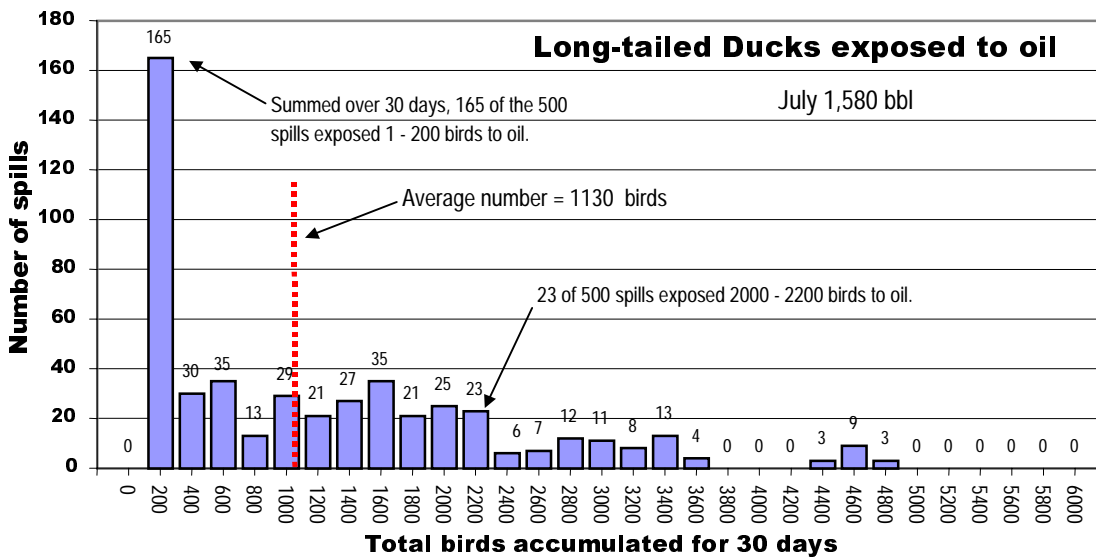

Figure 18. Number of long-tailed ducks exposed in 500 trajectories of 1580-barrel spills in July.

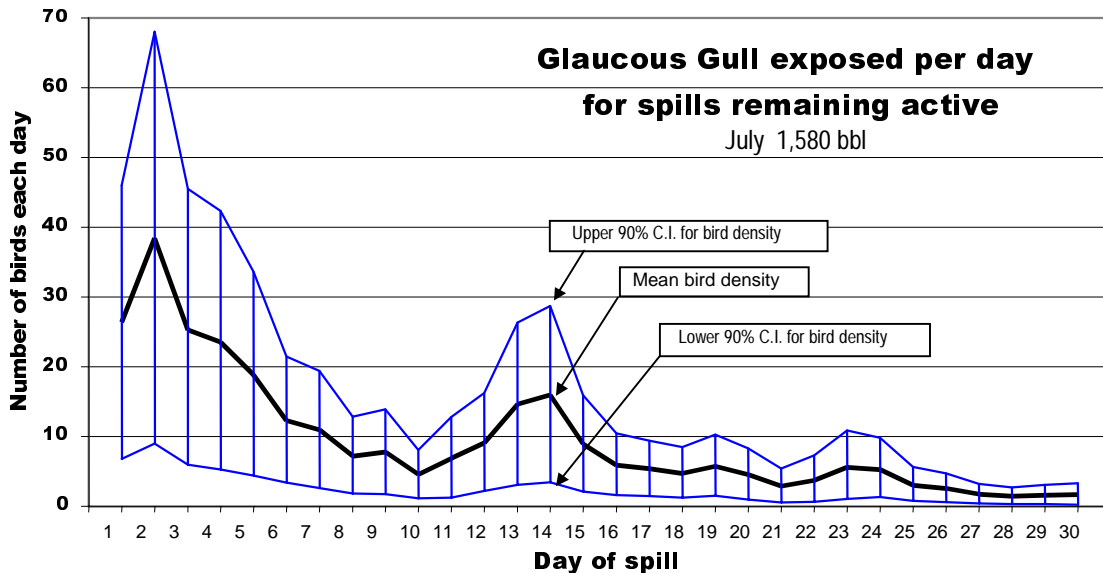
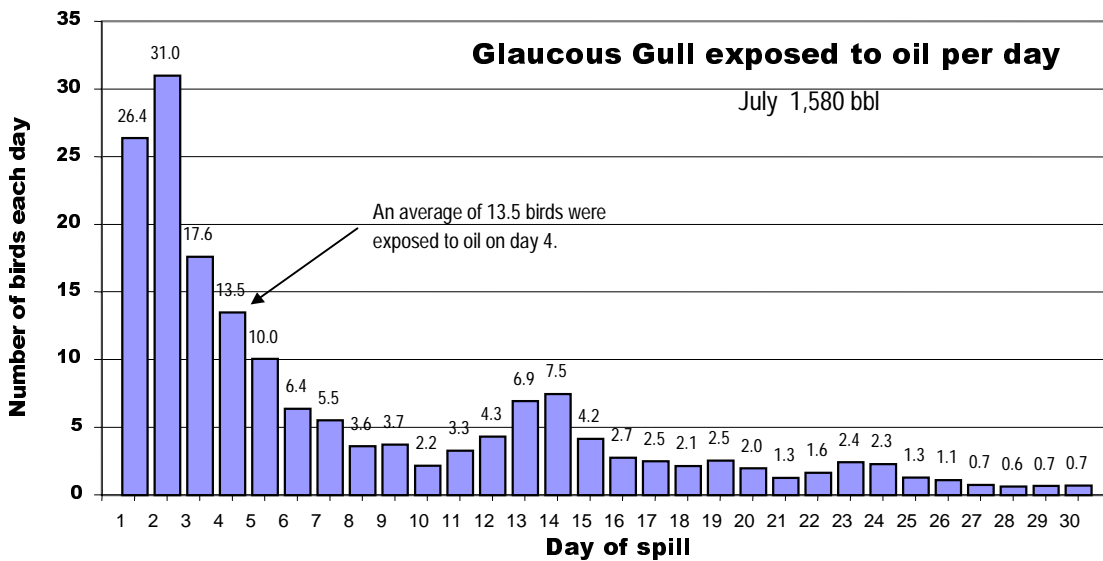
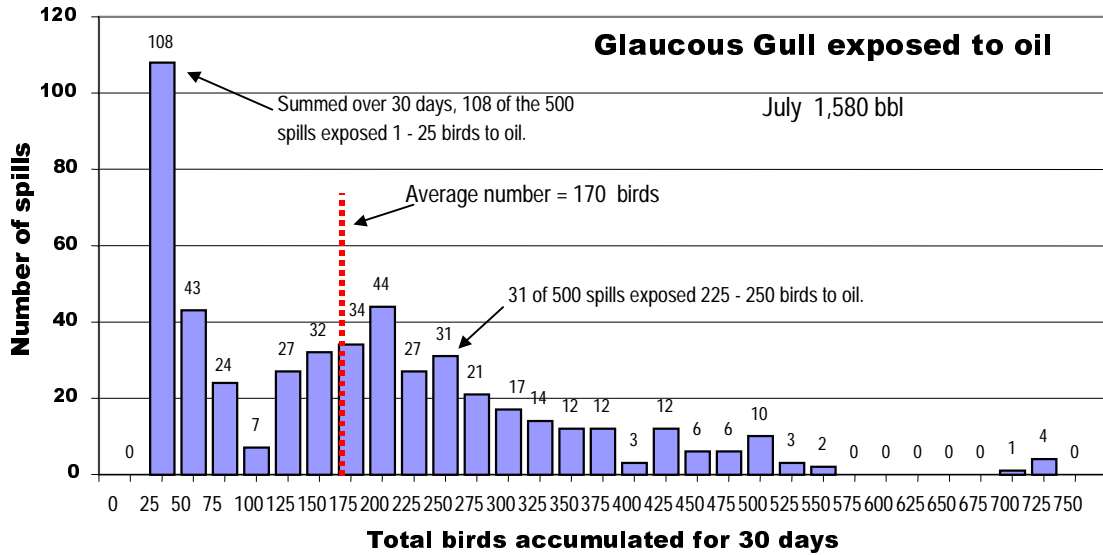

Figure 19. Number of glaucous gulls exposed in 500 trajectories of 1580-barrel spills in July.

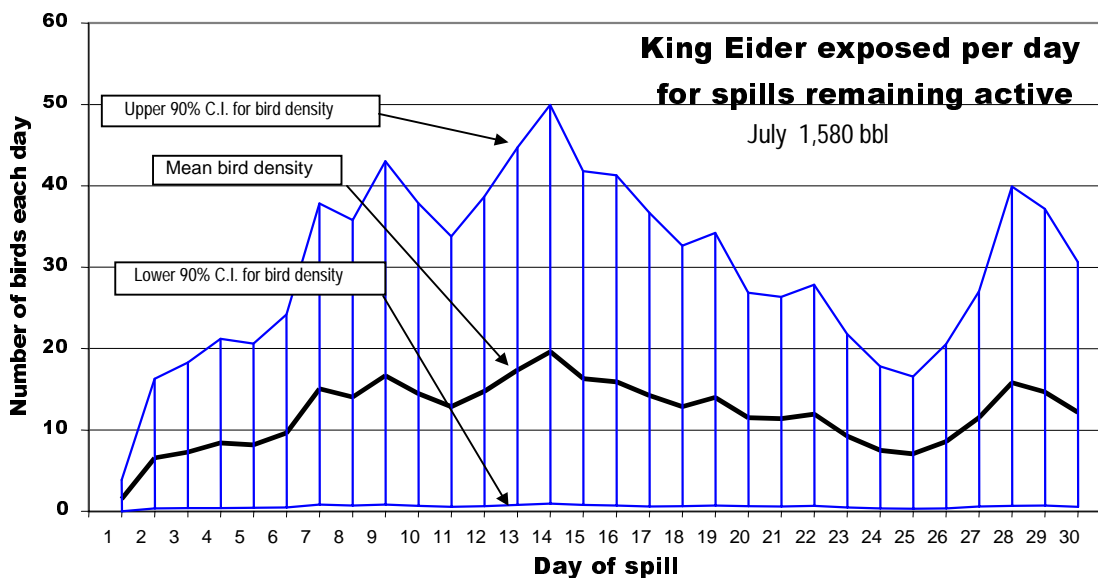
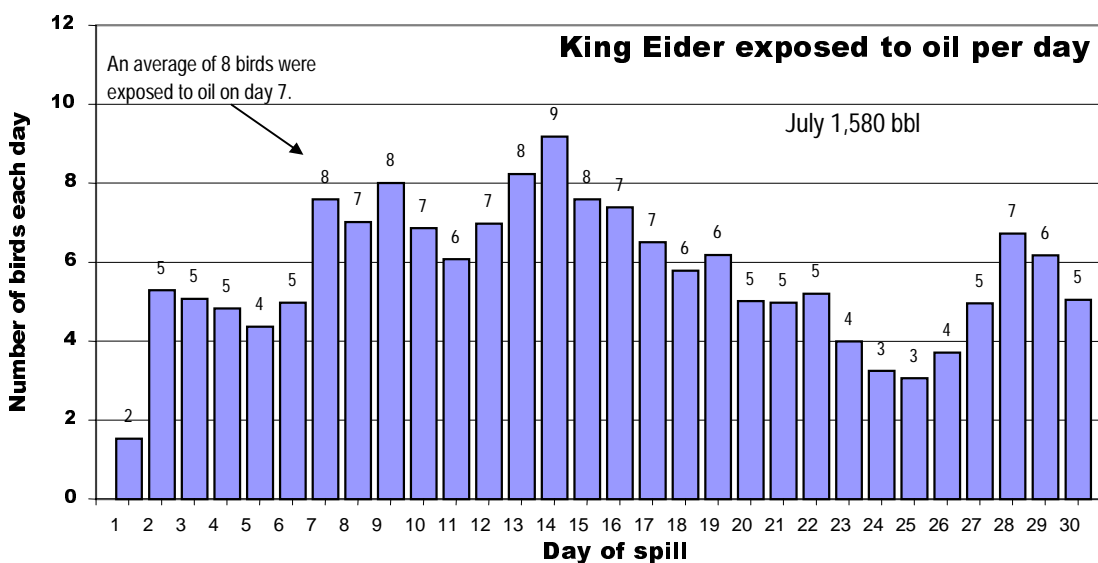
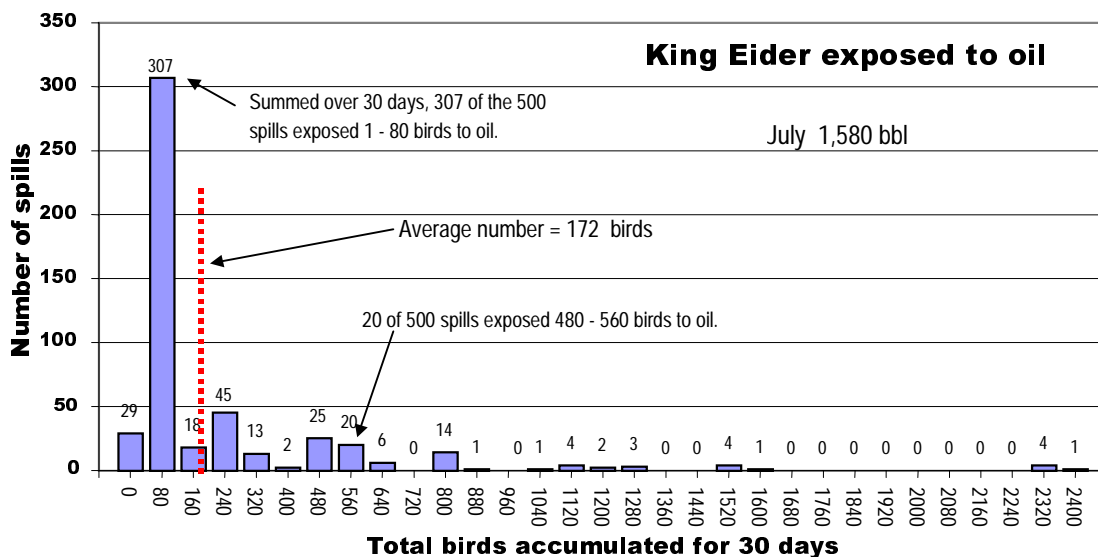

Figure 20. Number of king eider exposed in 500 trajectories of 1580-barrel spills in July.

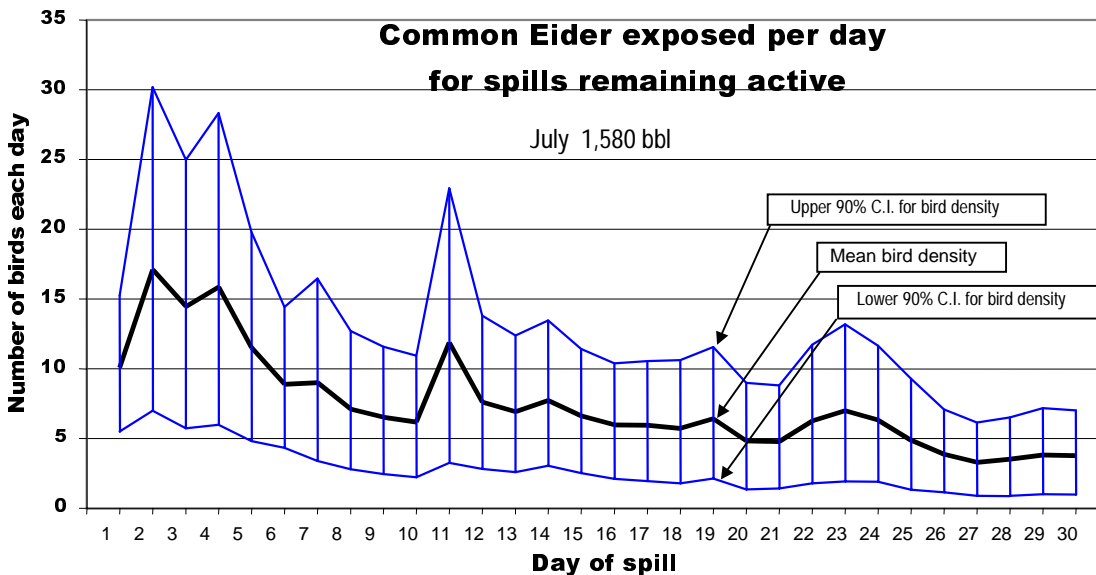
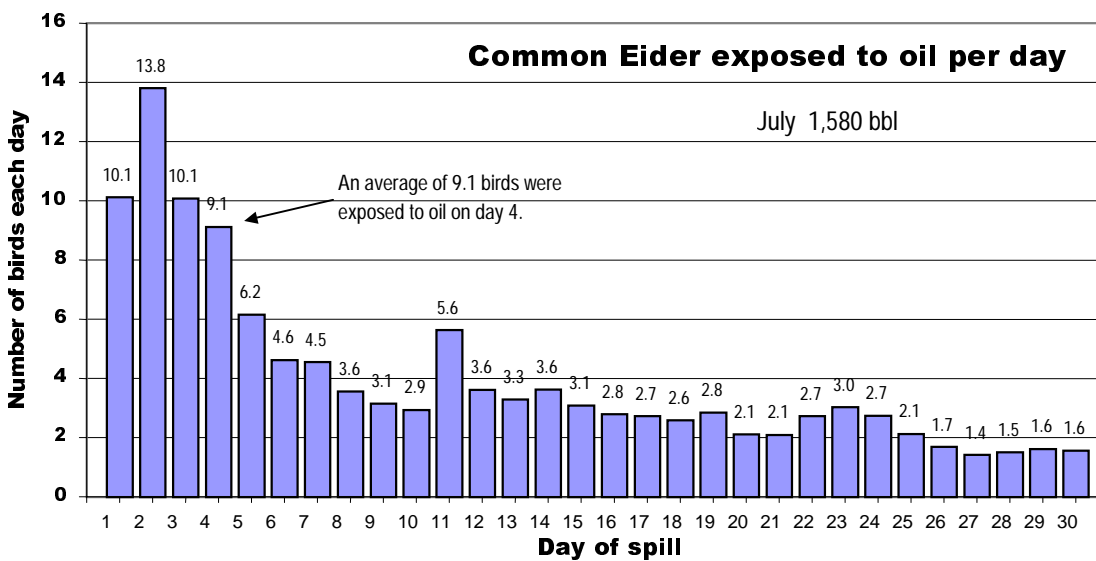
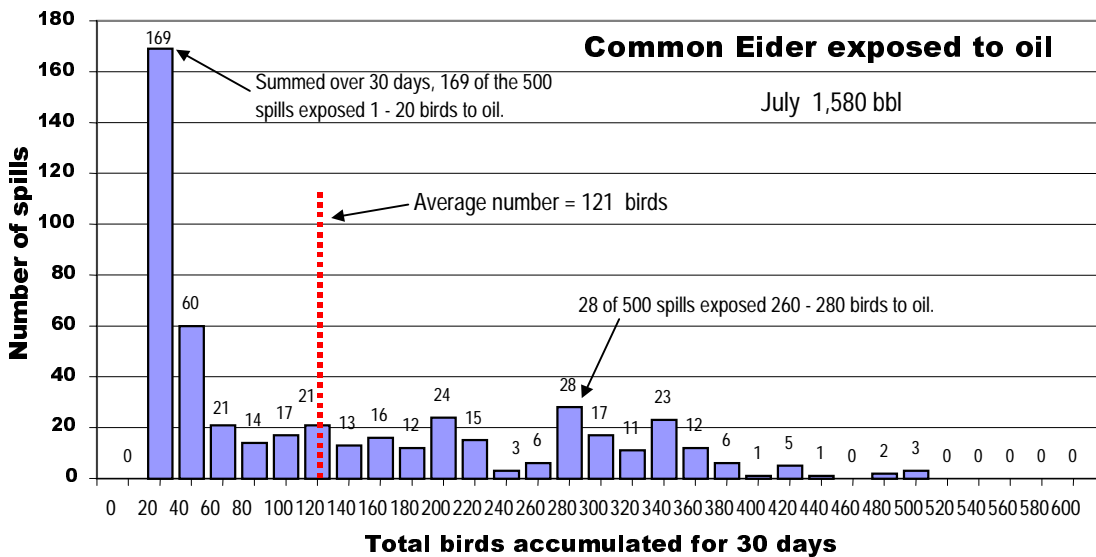

Figure 21. Number of common eider exposed in 500 trajectories of 1580-barrel spills in July.

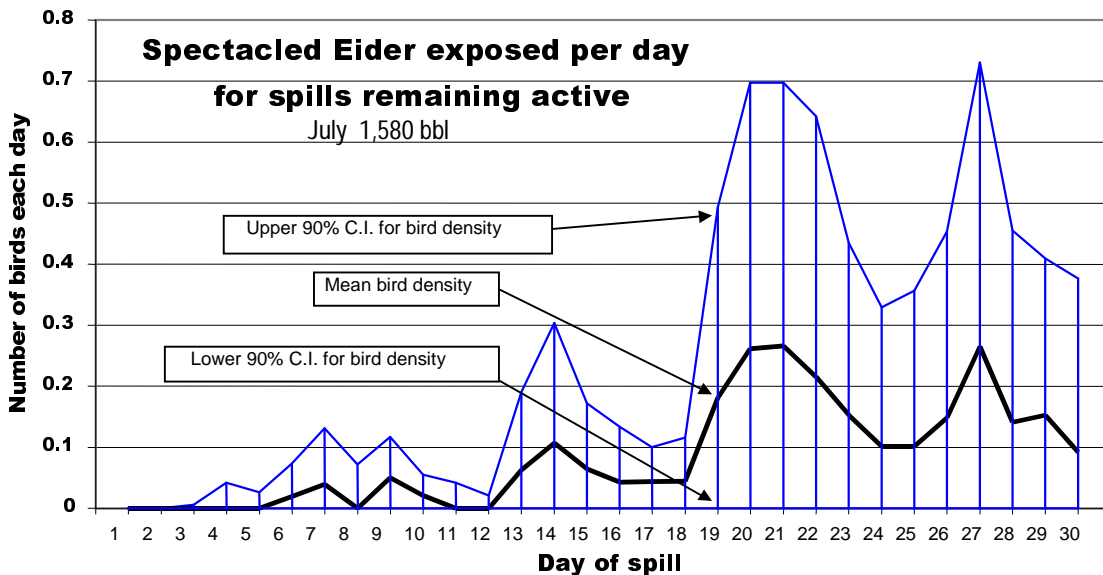
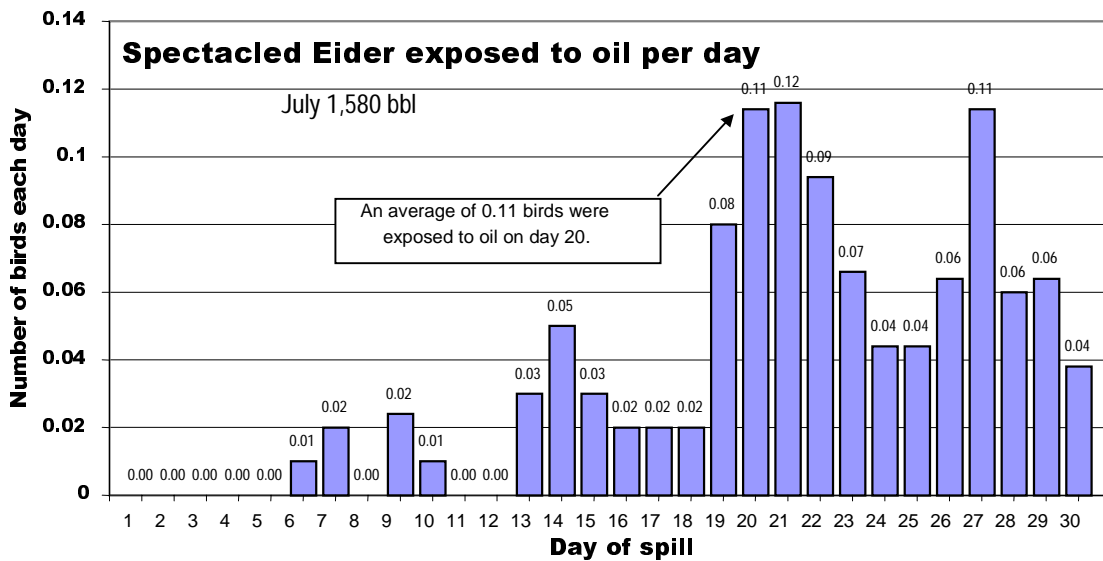
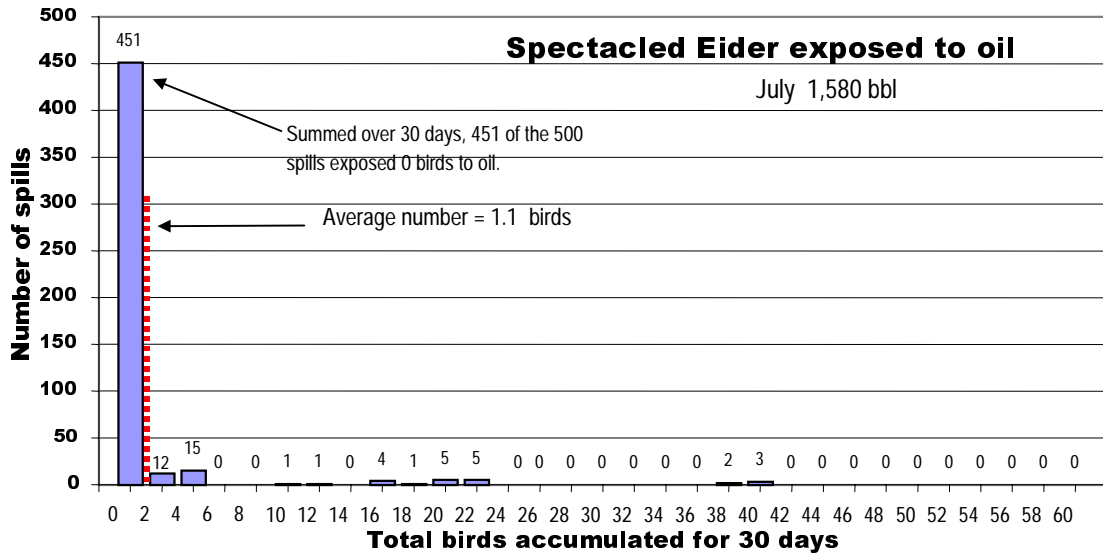

Figure 22. Number of spectacled eider exposed in 500 trajectories of 1580-barrel spills in July.

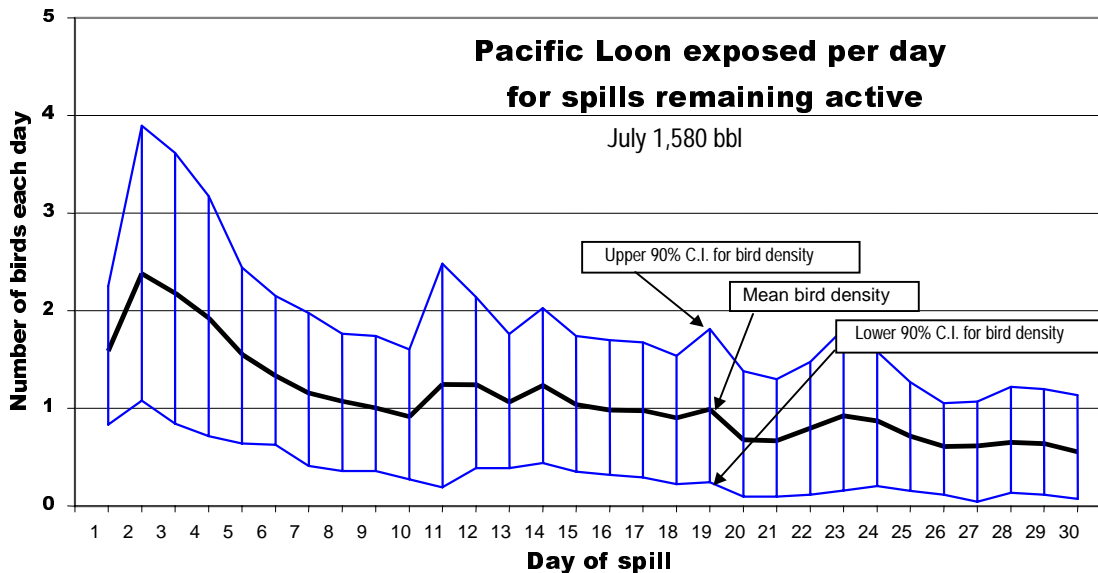
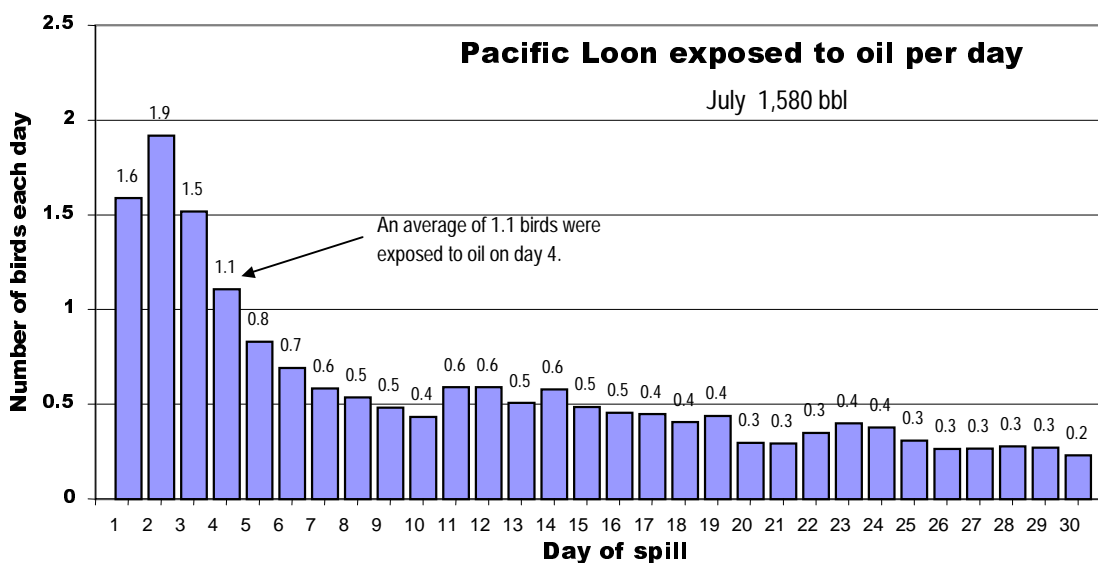
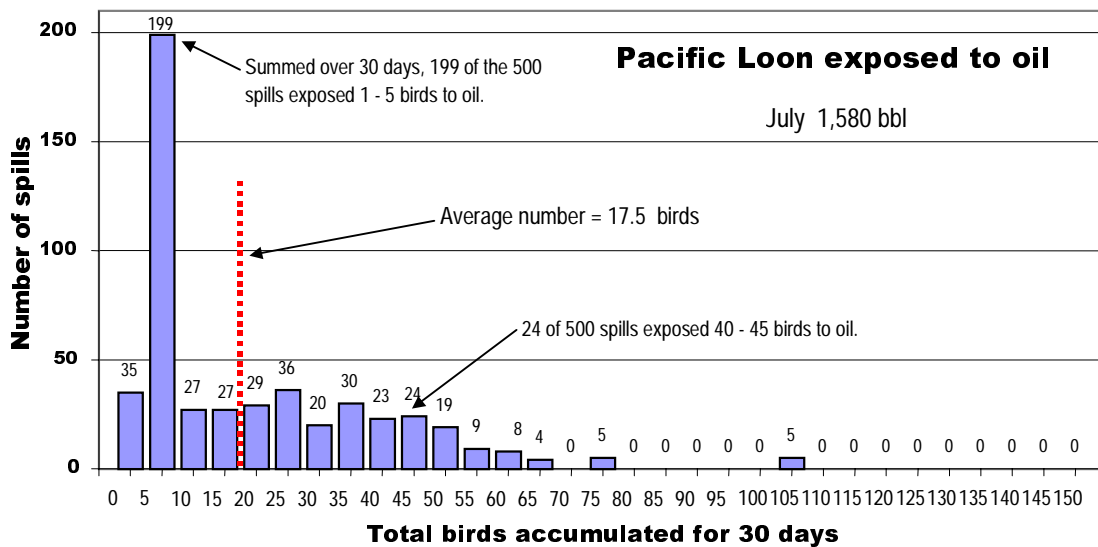

Figure 23. Number of Pacific loons exposed in 500 trajectories of 1580-barrel spills in July.

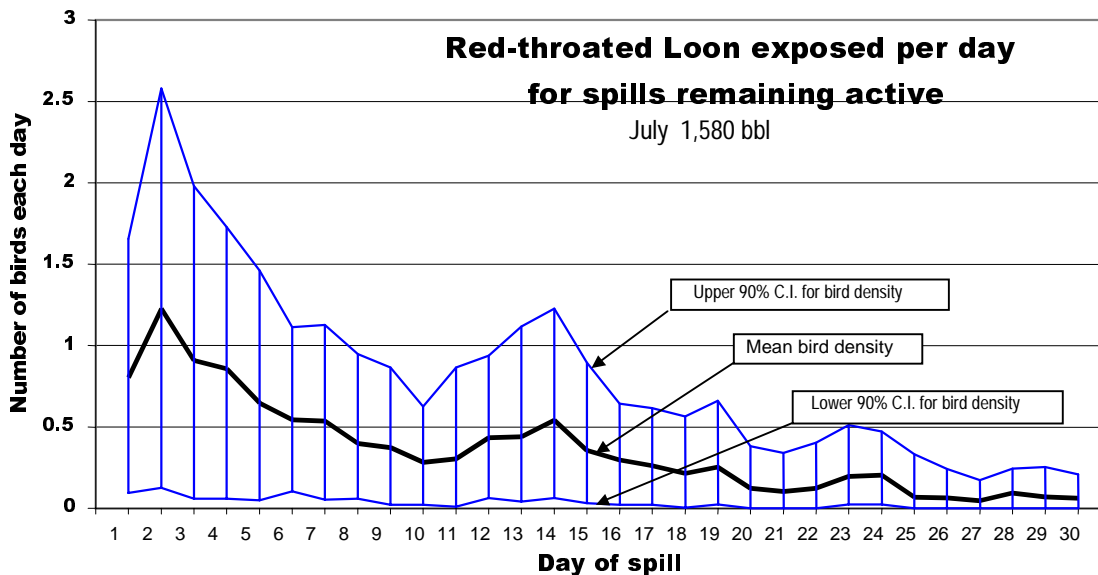
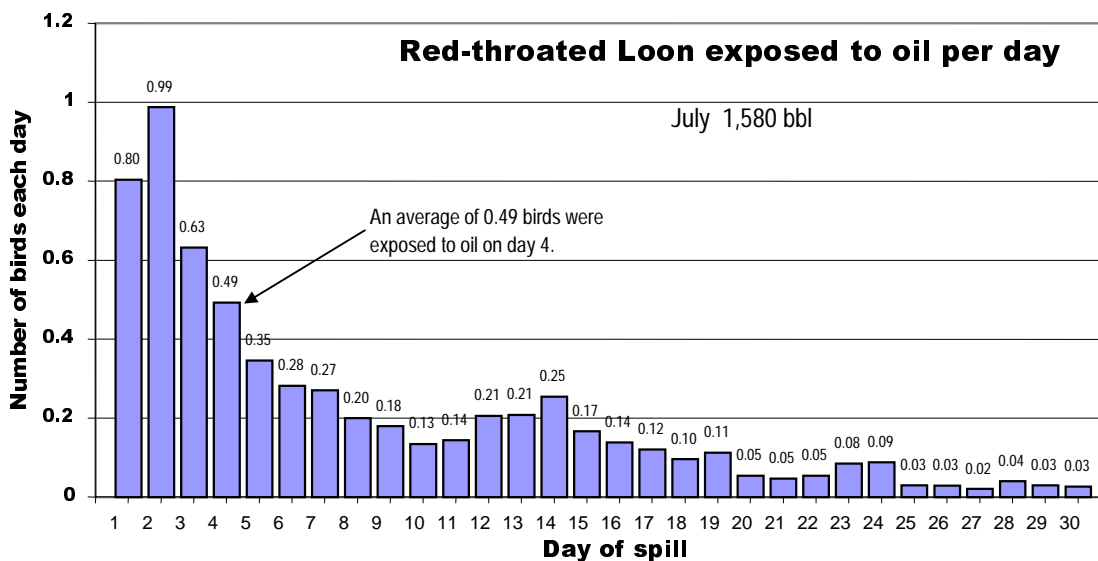
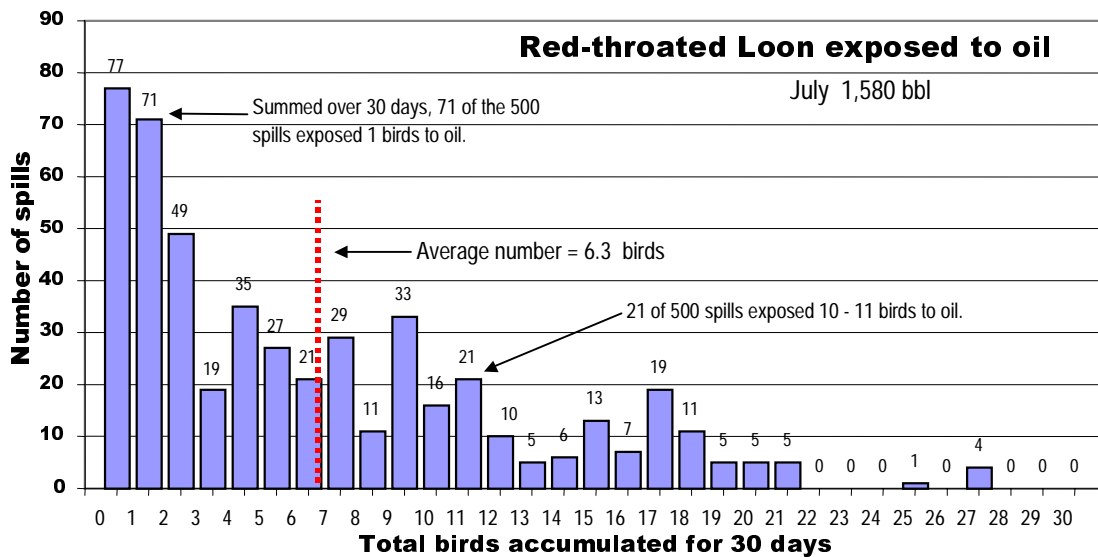

Figure 24. Number of red-throated loons exposed in 500 trajectories of 1500-barrel spills in July.

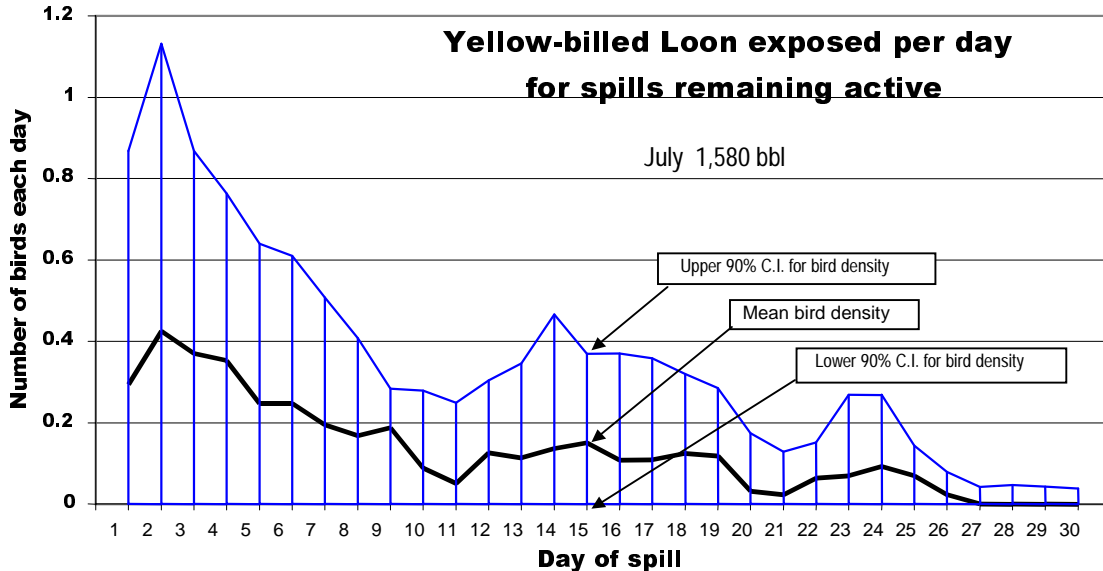
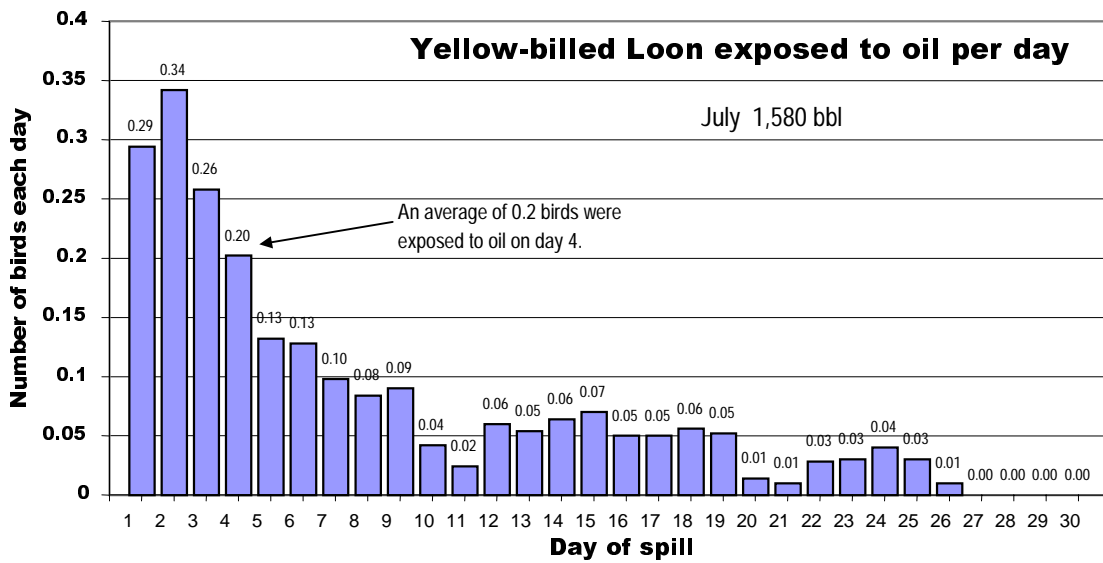
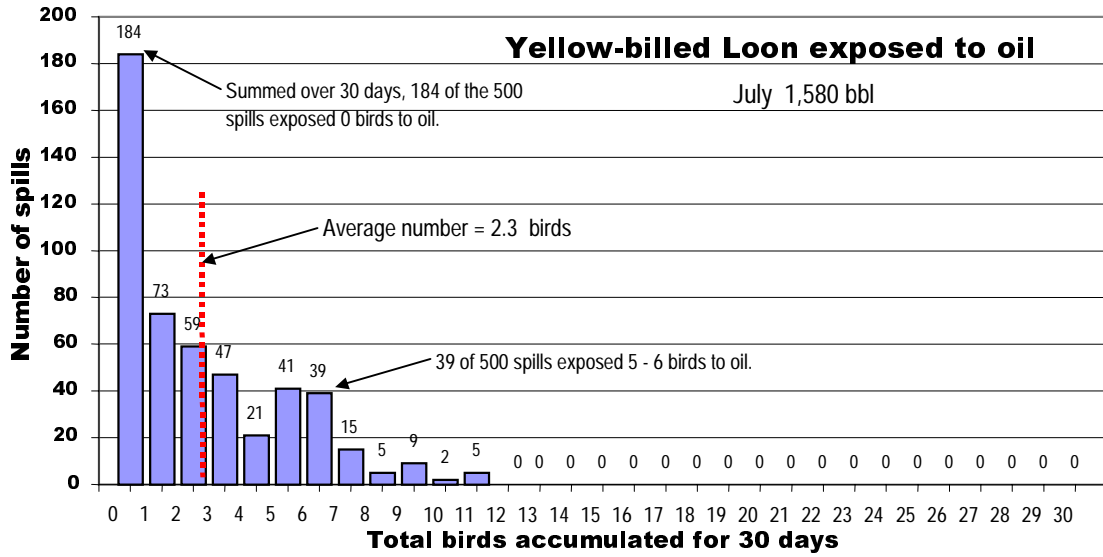

Figure 25. Number of yellow-billed loons exposed in 500 trajectories of 1580-barrel spills in July.

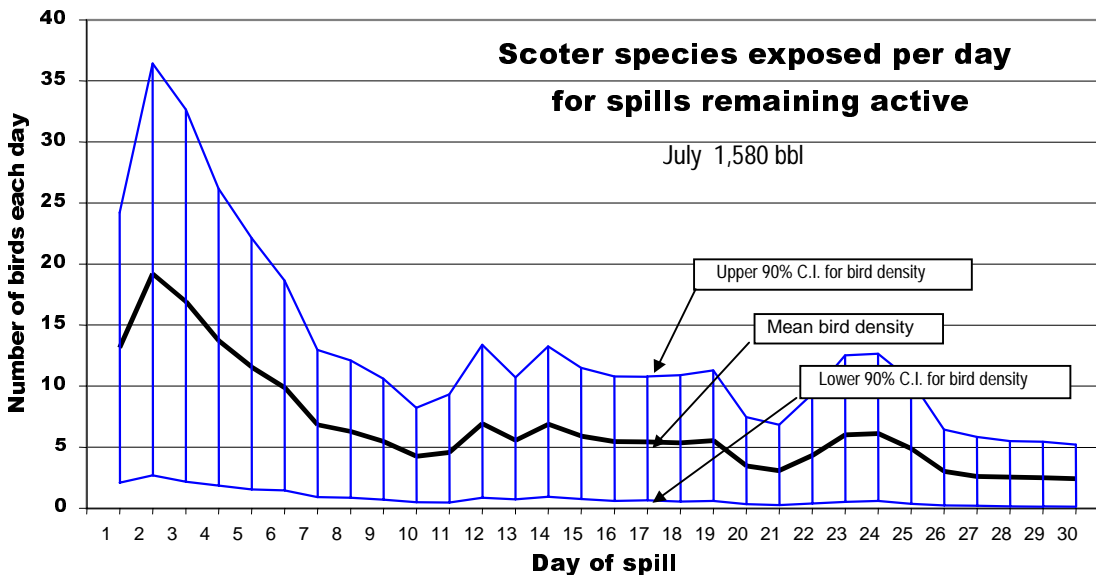
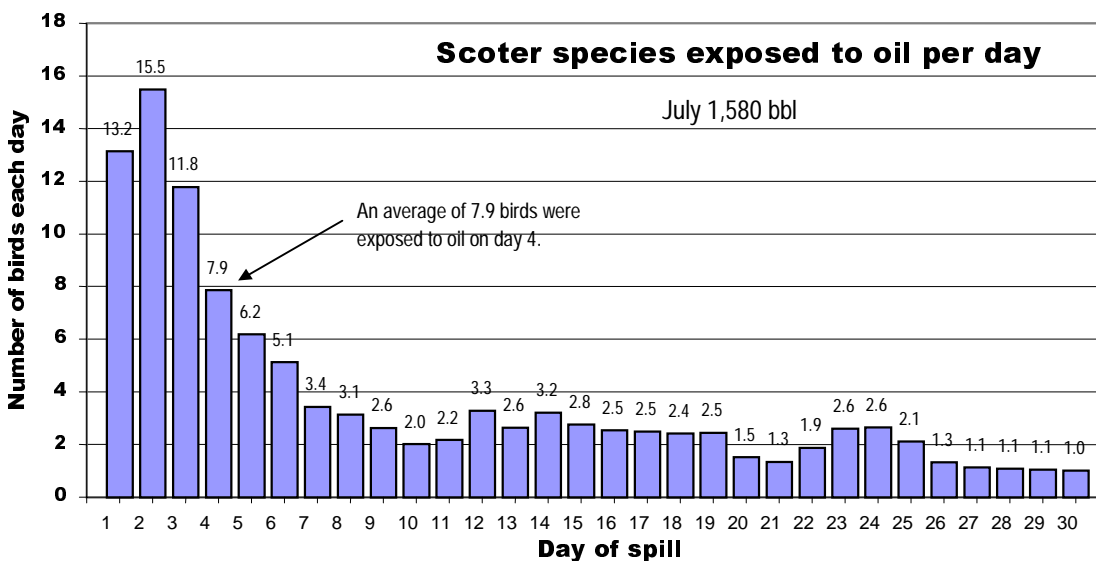
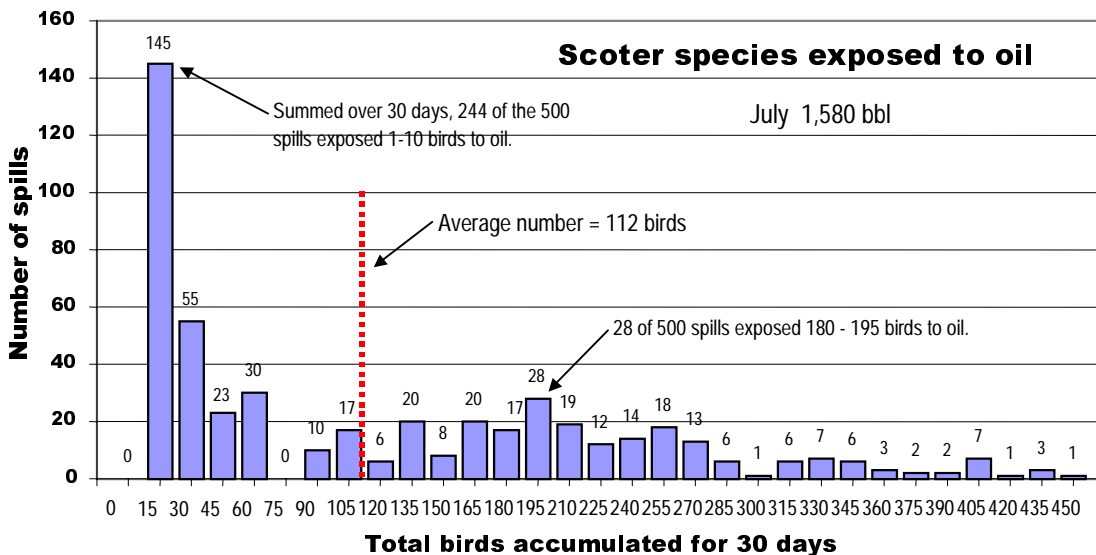

Figure 26. Number of scoters exposed in 500 trajectories of 1580-barrel spills in July.

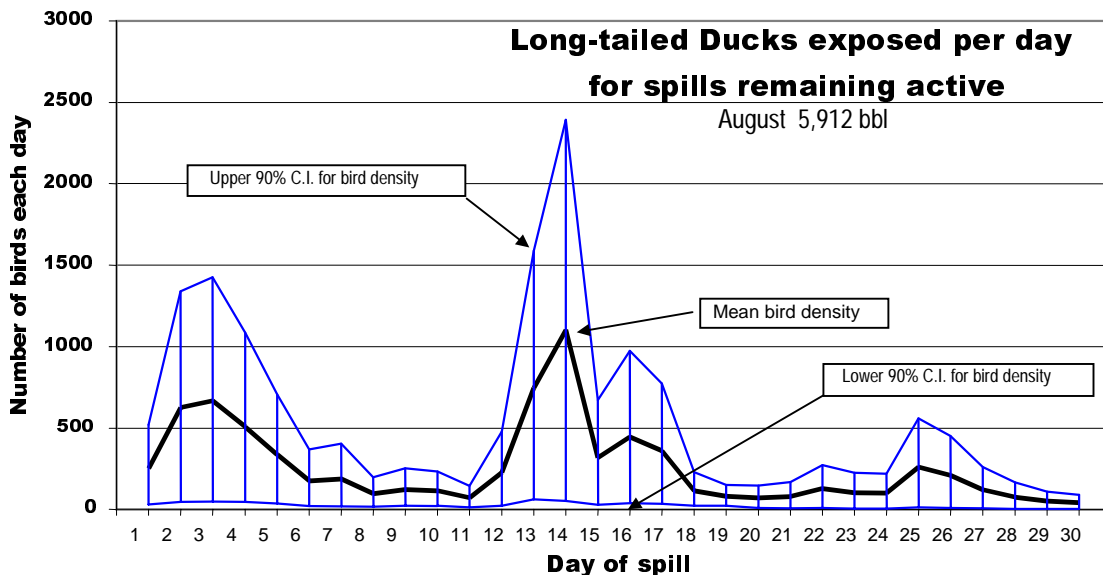
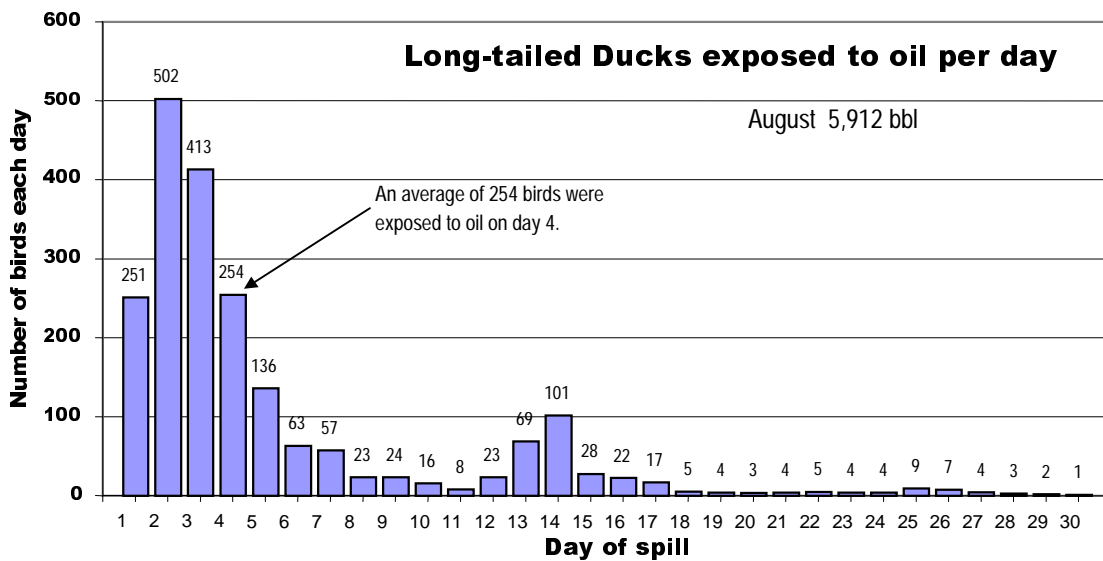
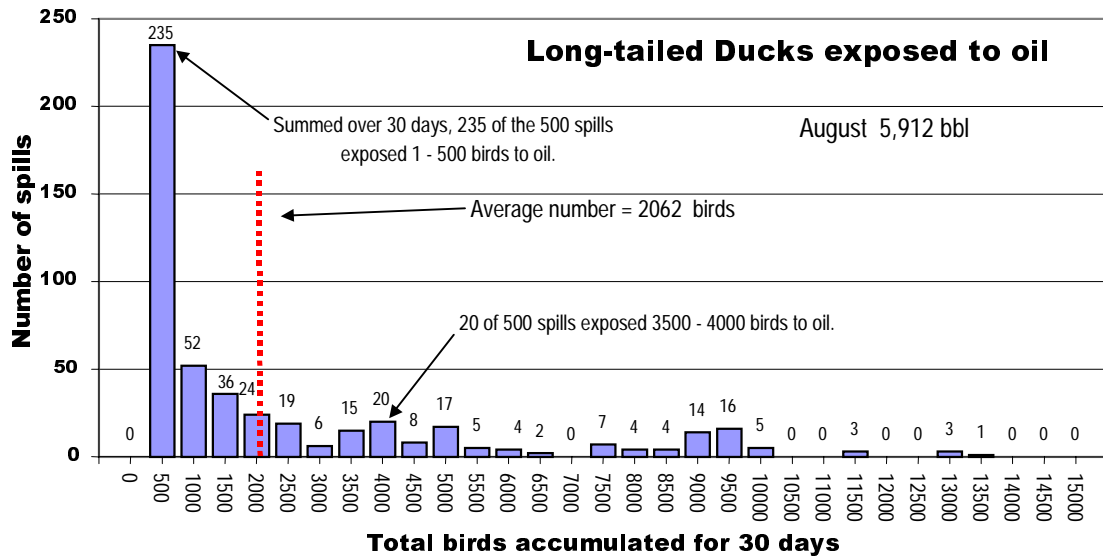

Figure 27. Number of long-tailed ducks exposed in 500 trajectories of 5912-barrel spills in August.

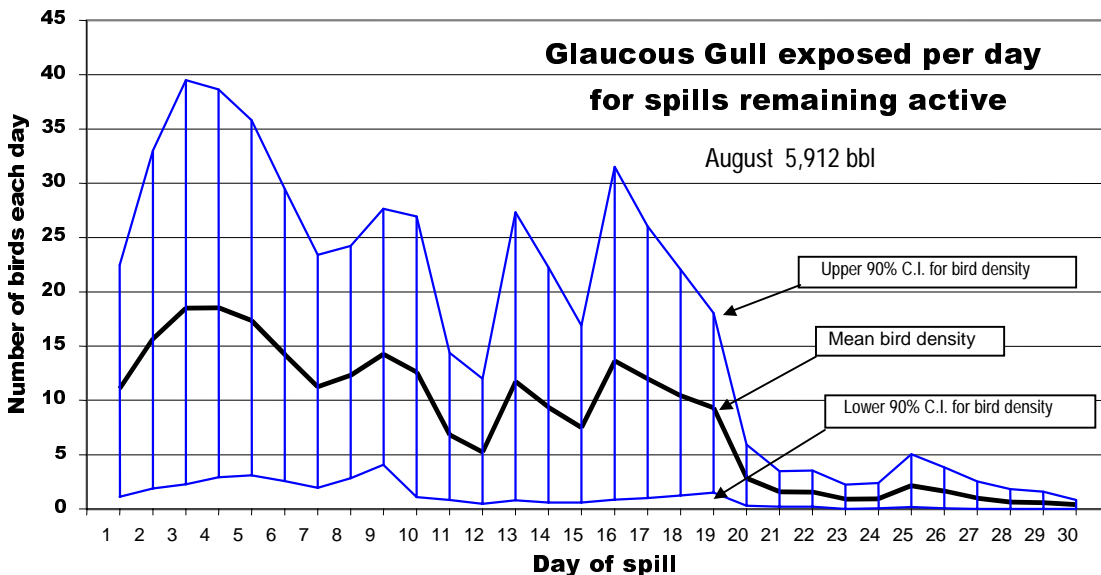
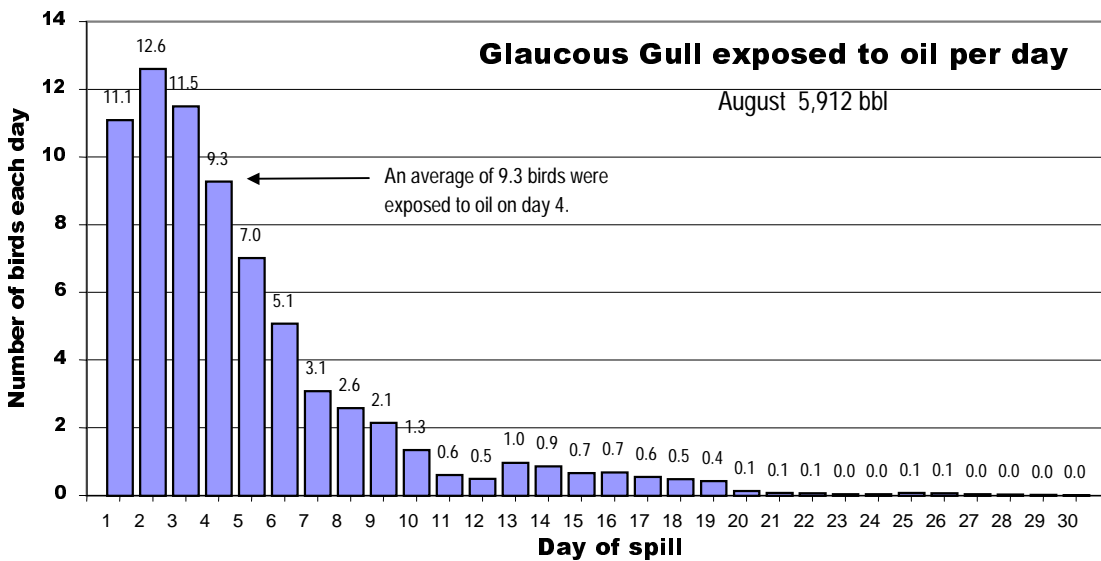
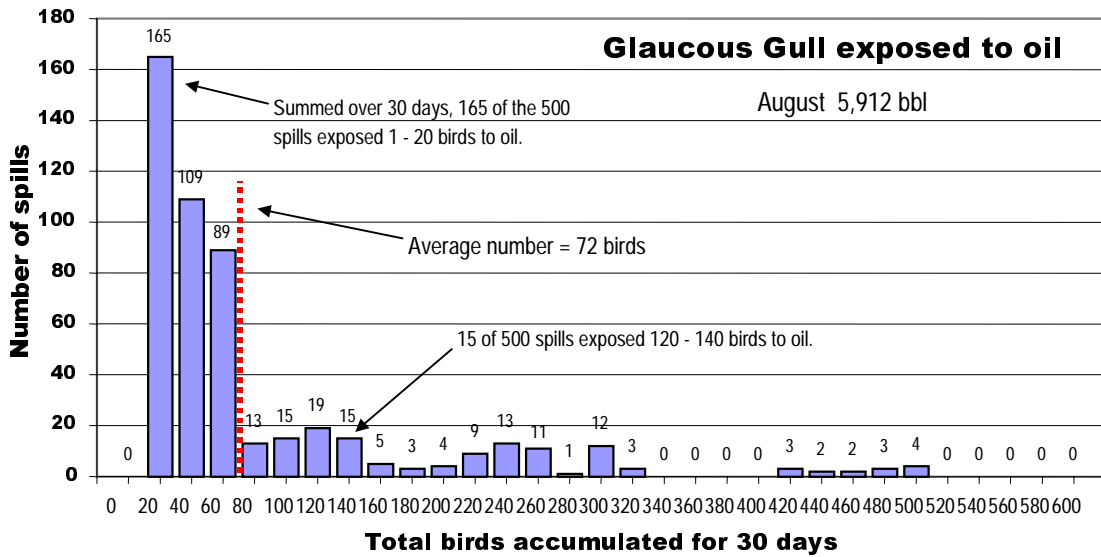

Figure 28. Number of glaucous gulls exposed in 500 trajectories of 5912-barrel spills in August.

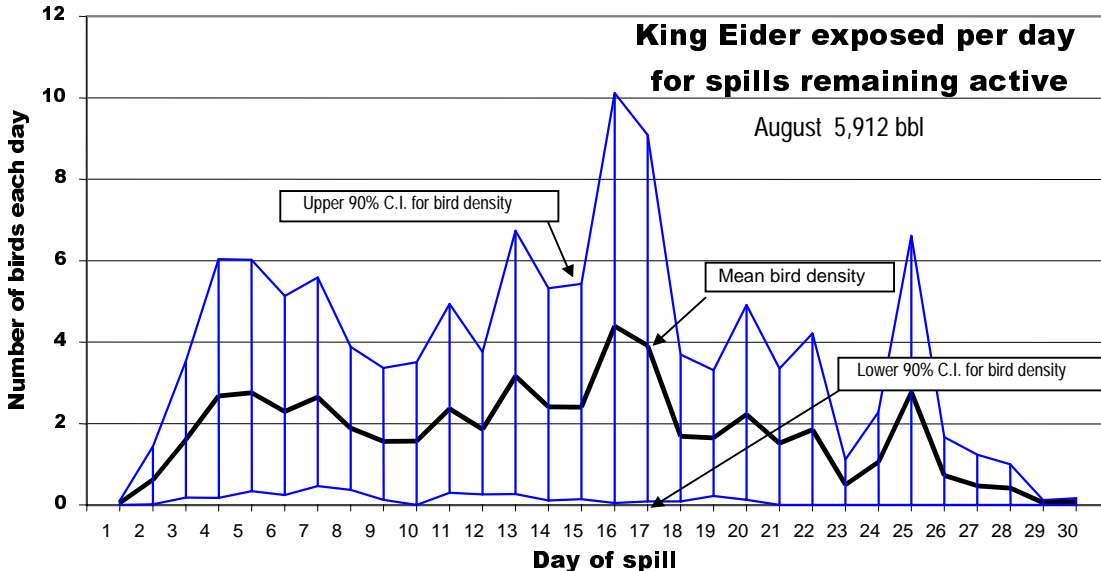
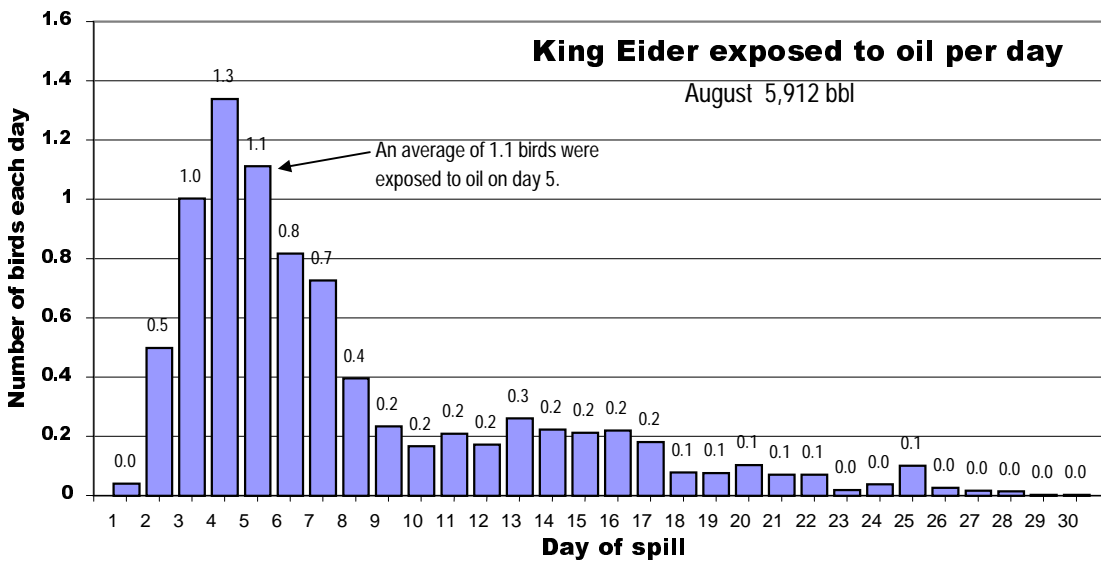
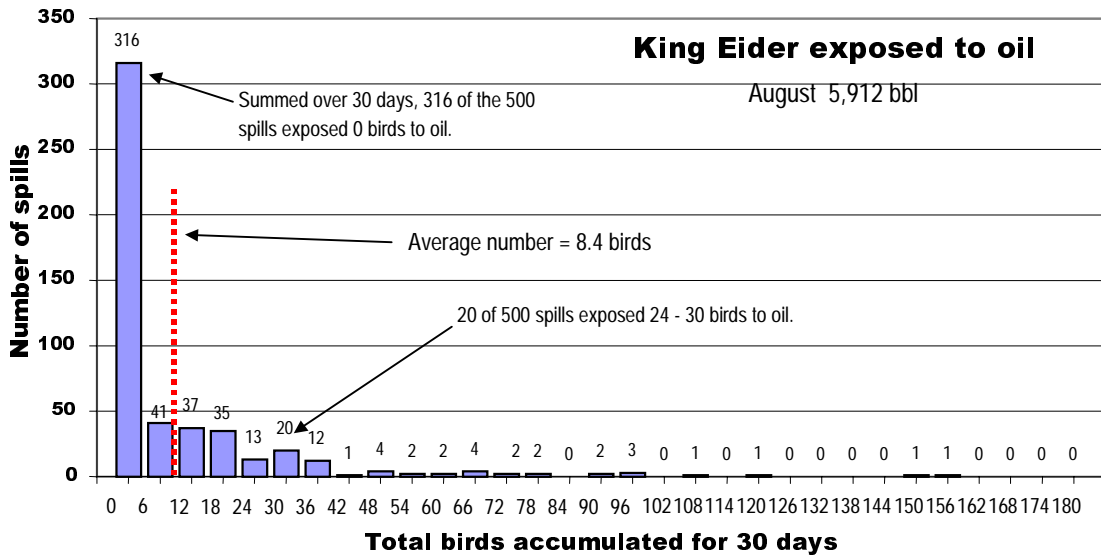

Figure 29. Number of king eider exposed in 500 trajectories of 5912-barrel spills in August.

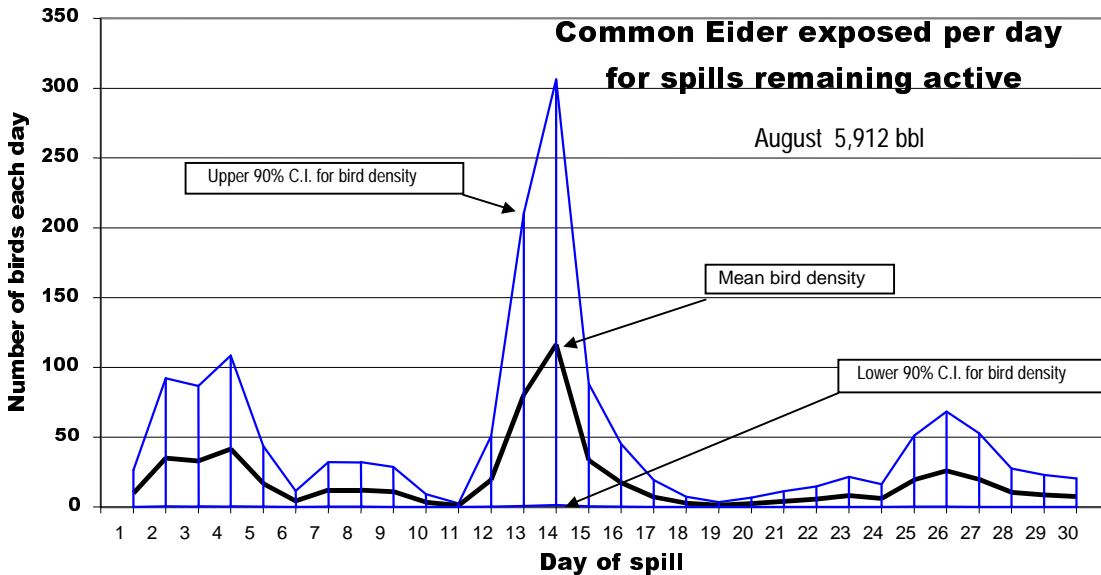
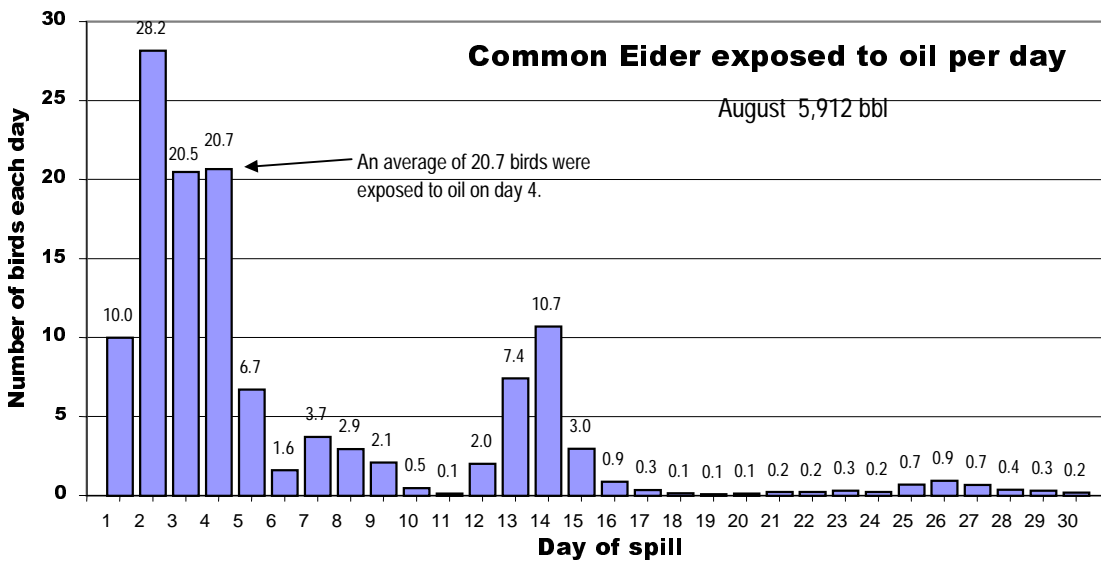
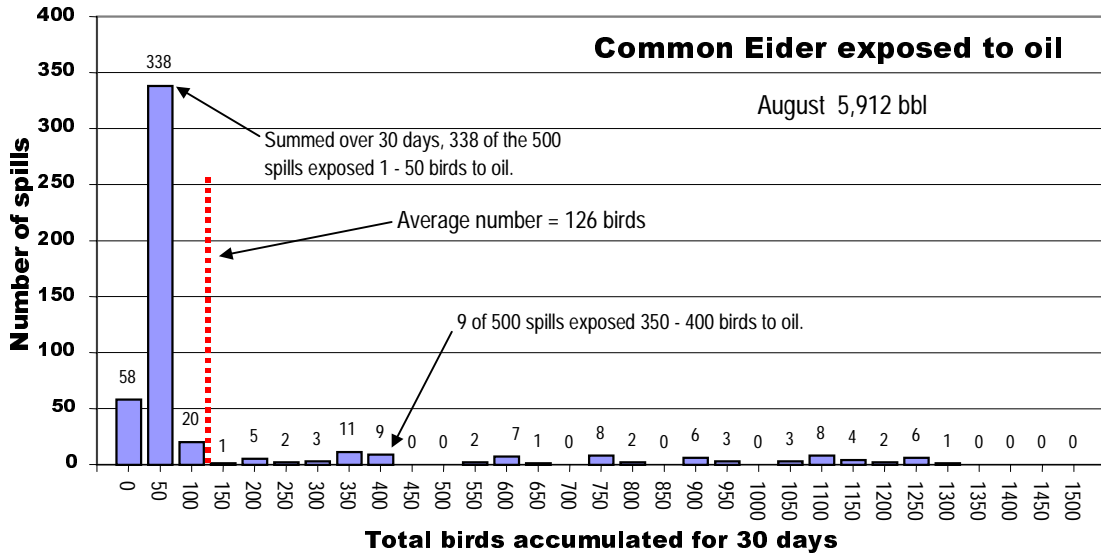

Figure 30. Number of common eider exposed in 500 trajectories of 5912-barrel spills in August.

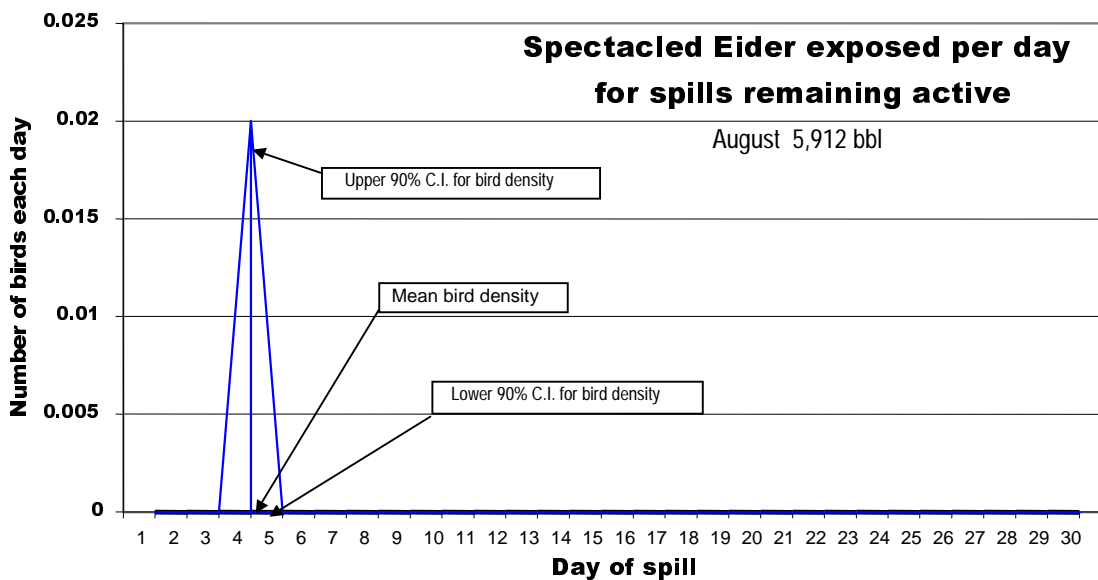
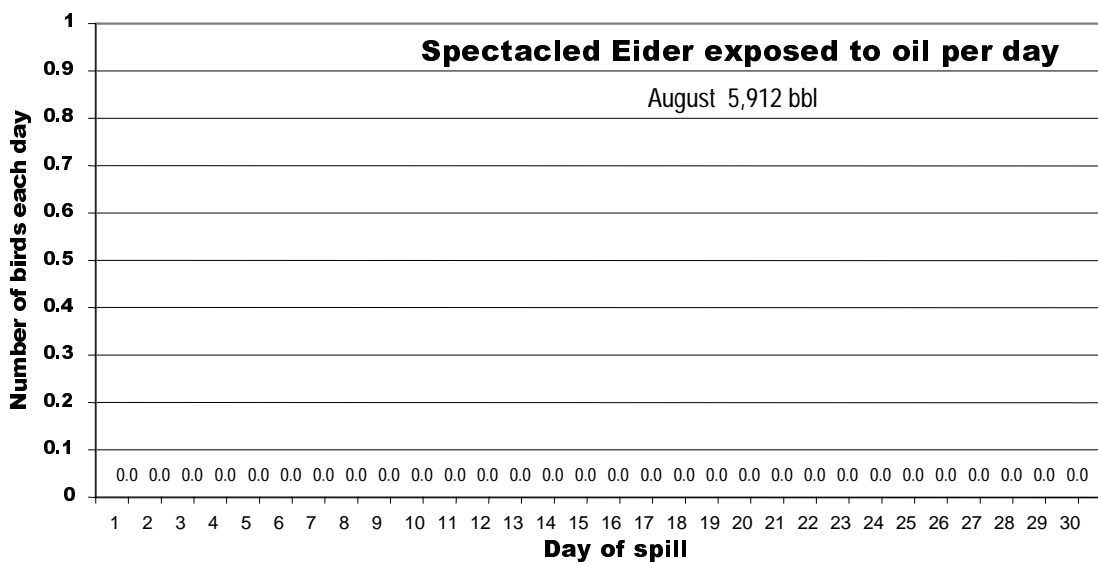
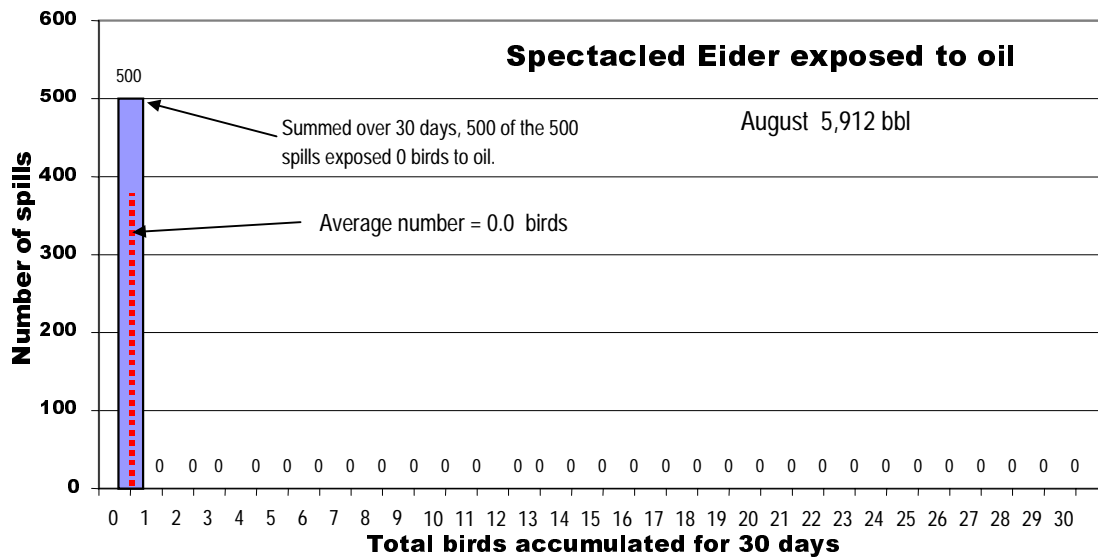

Figure 31. Number of spectacled eider exposed in 500 trajectories of 5912-barrel spills in August.

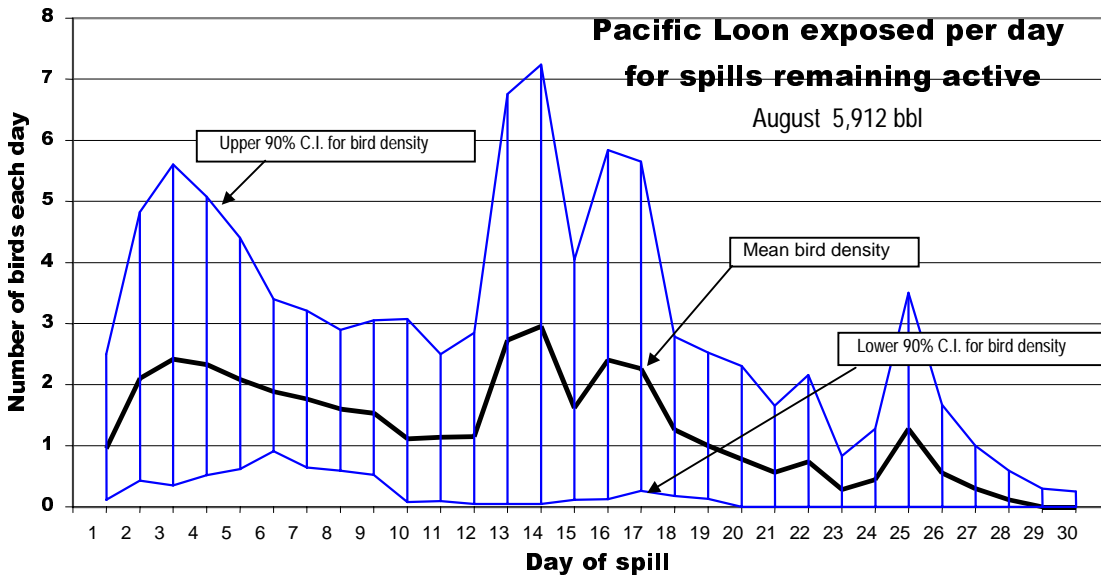
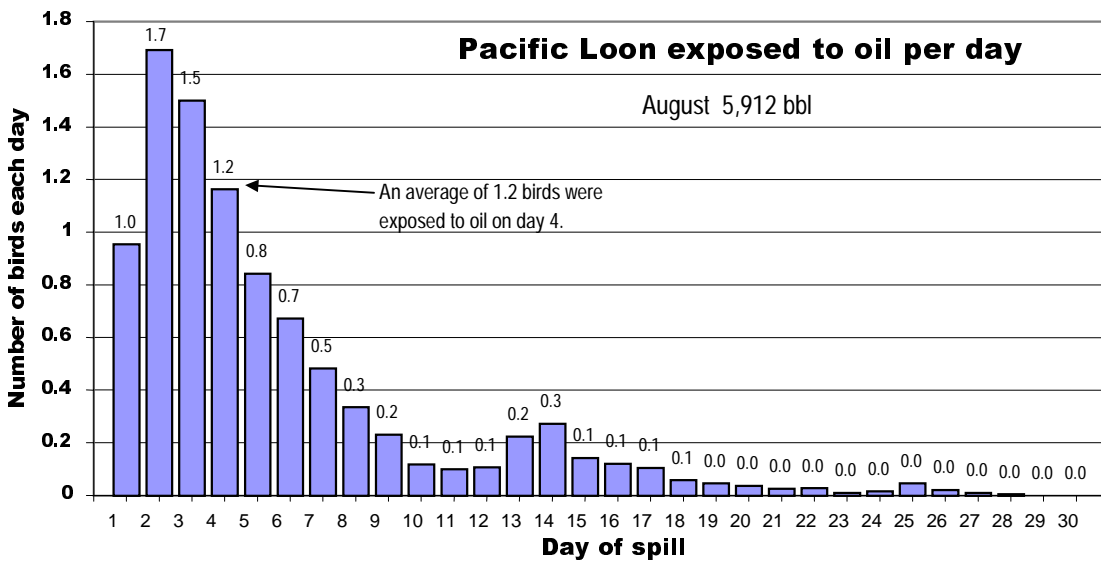
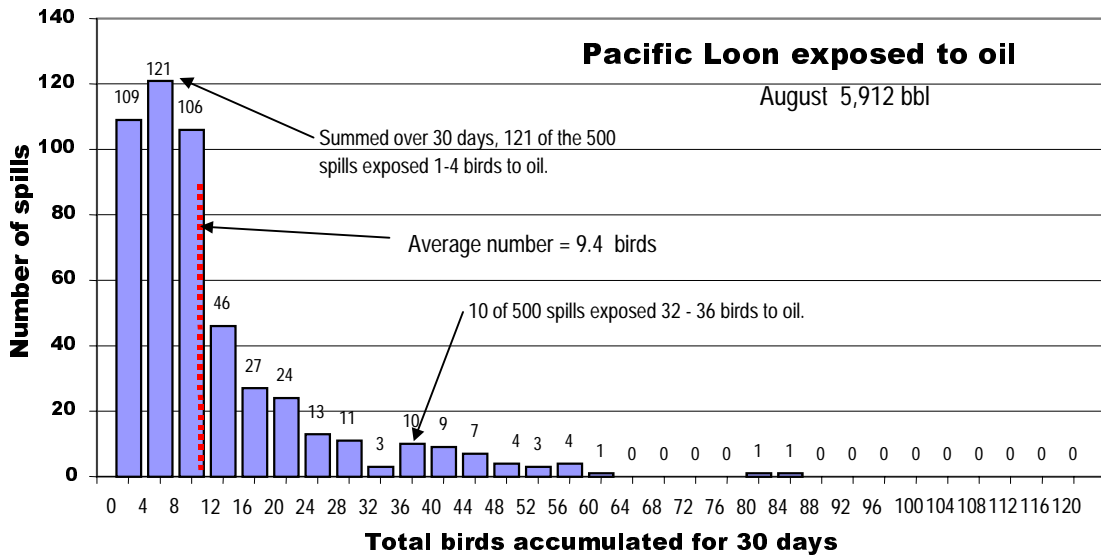

Figure 32. Number of Pacific loons exposed in 500 trajectories of 5912-barrel spills in August.

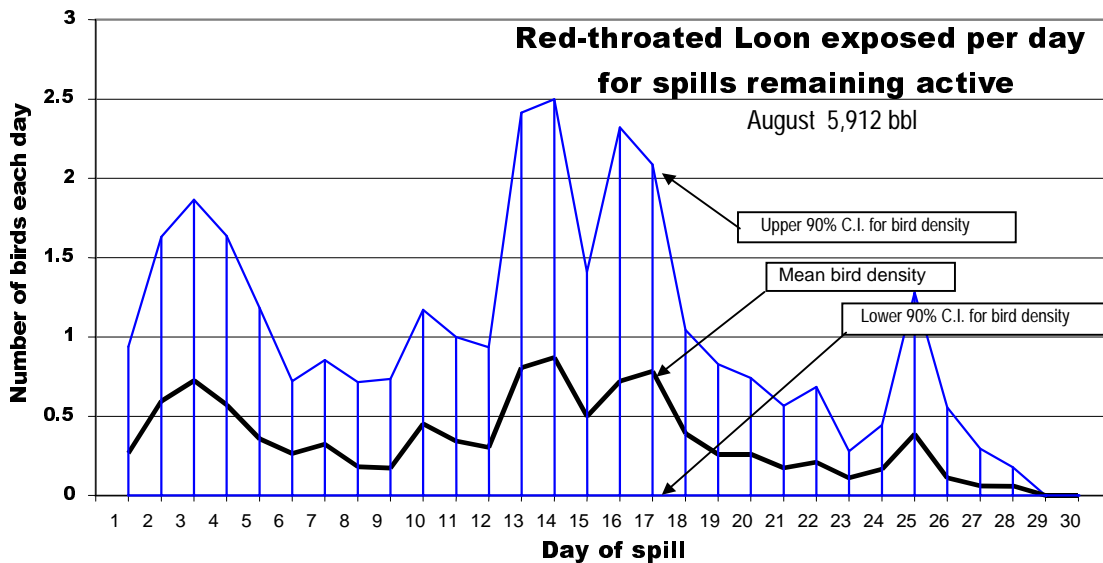
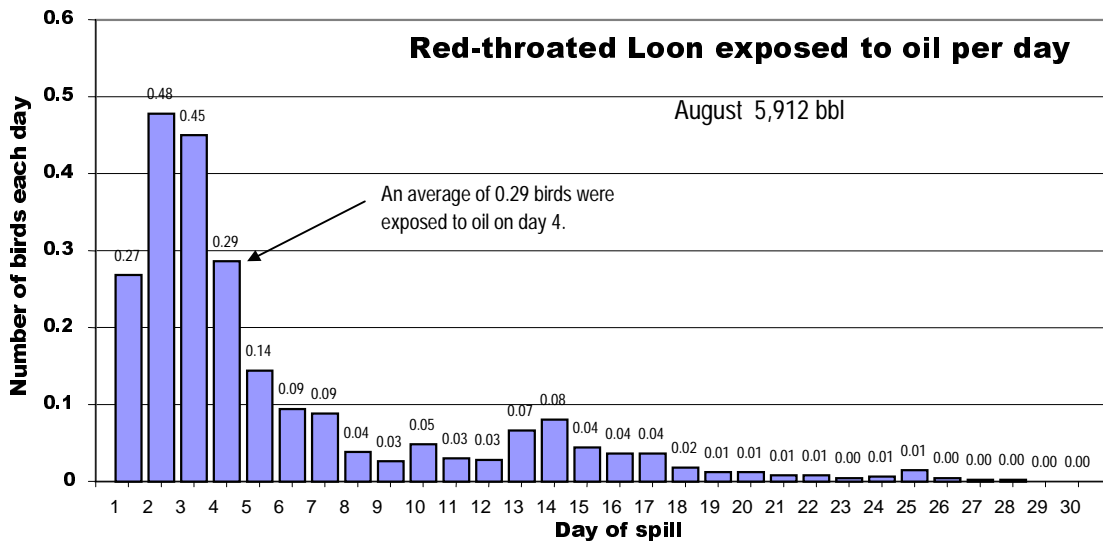
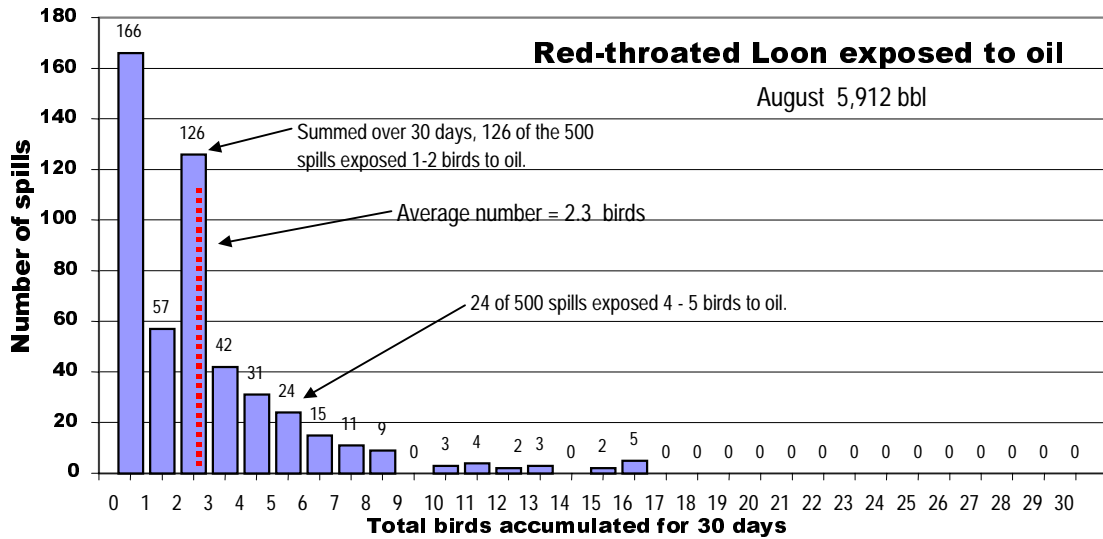

Figure 33. Number of red-throated loons exposed in 500 trajectories of 5912-barrel spills in August.

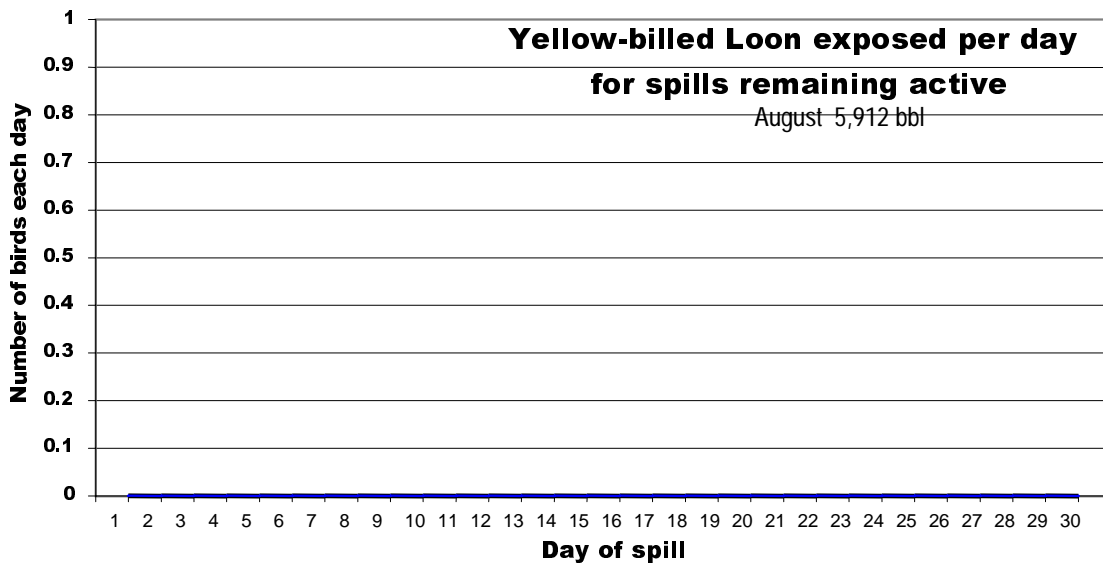
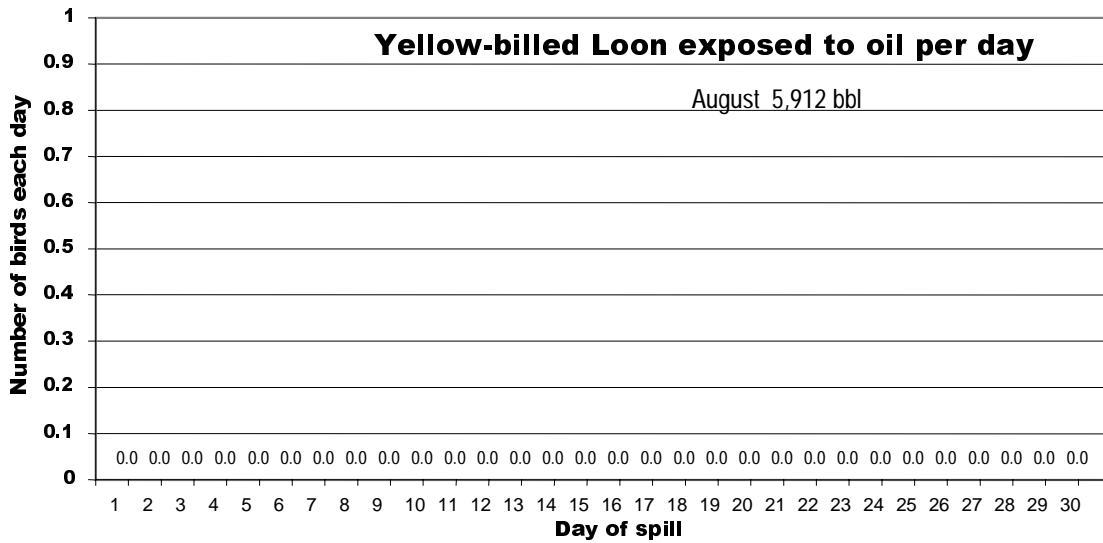
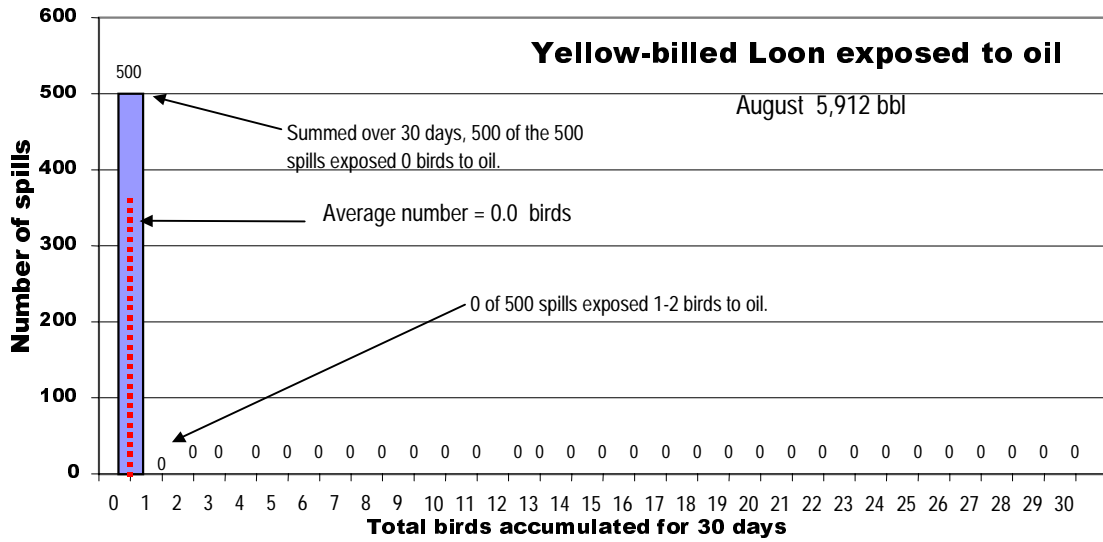

Figure 34. Number of yellow-billed loons exposed in 500 trajectories of 5912-barrel spills in August.

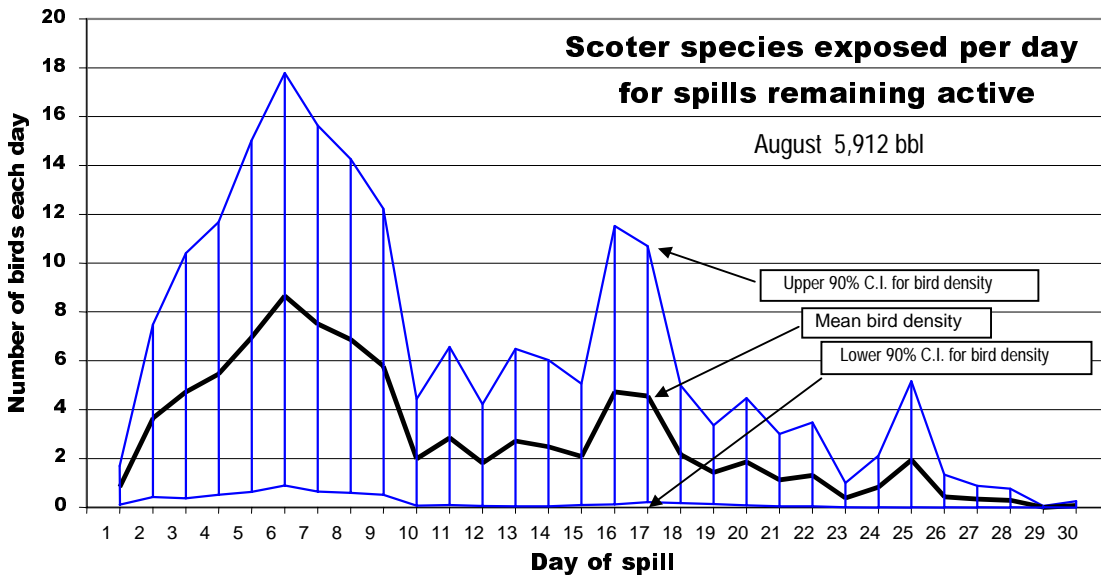
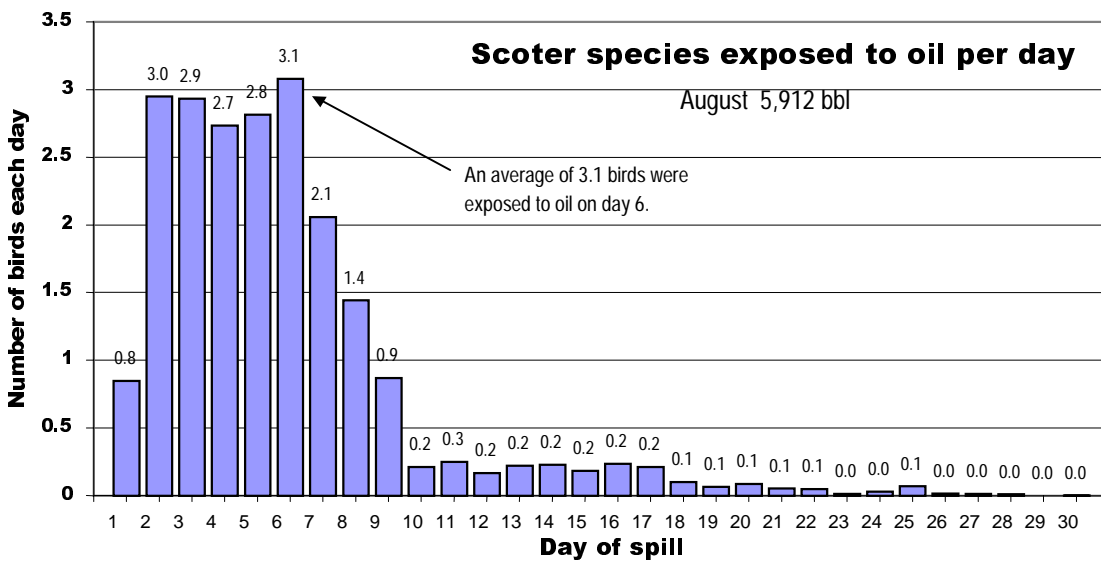
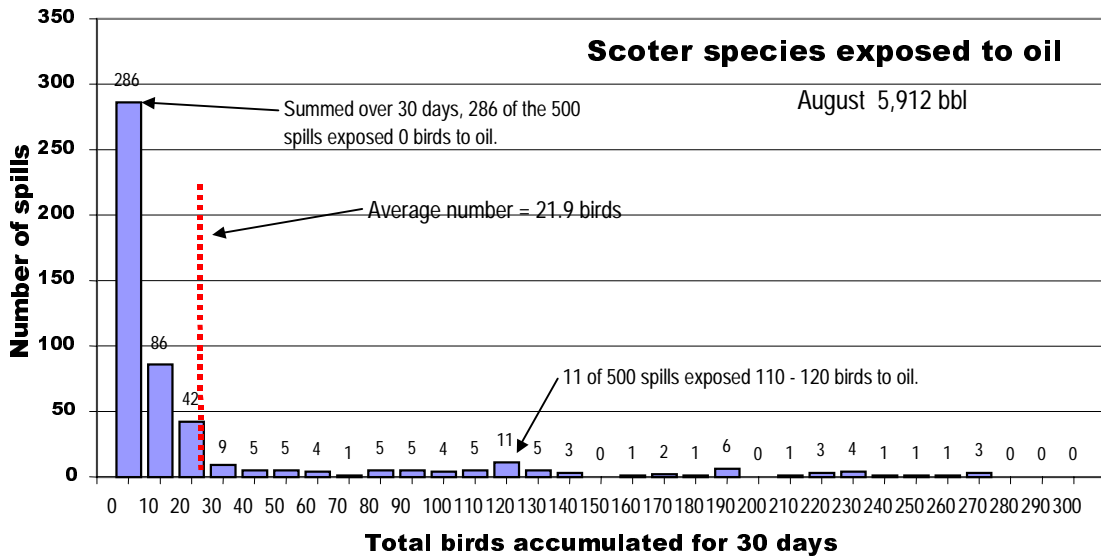

Figure 35. Number of scoters exposed in 500 trajectories of 5912-barrel spills in August.

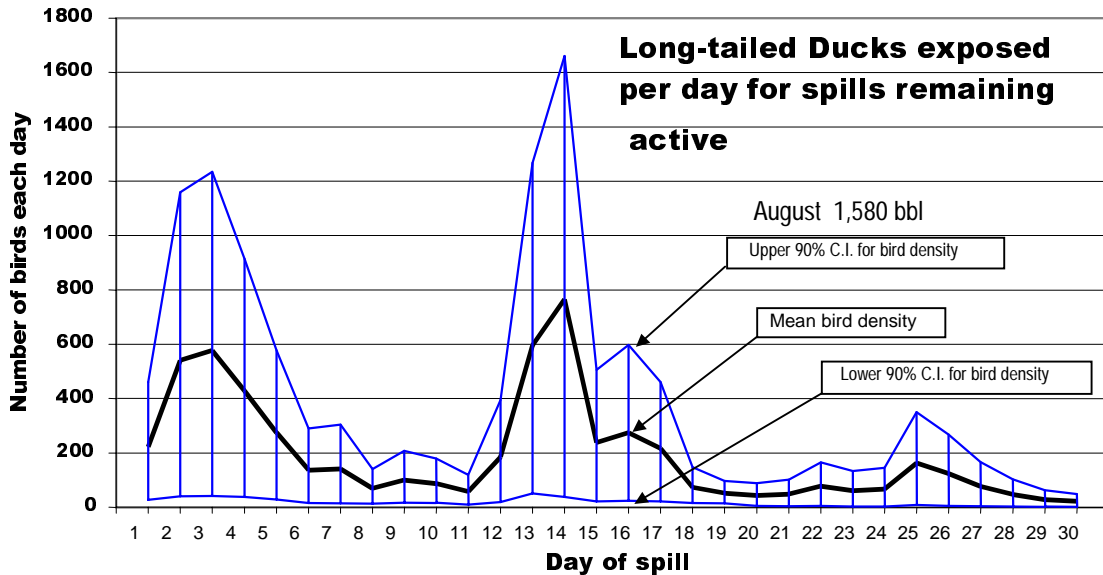
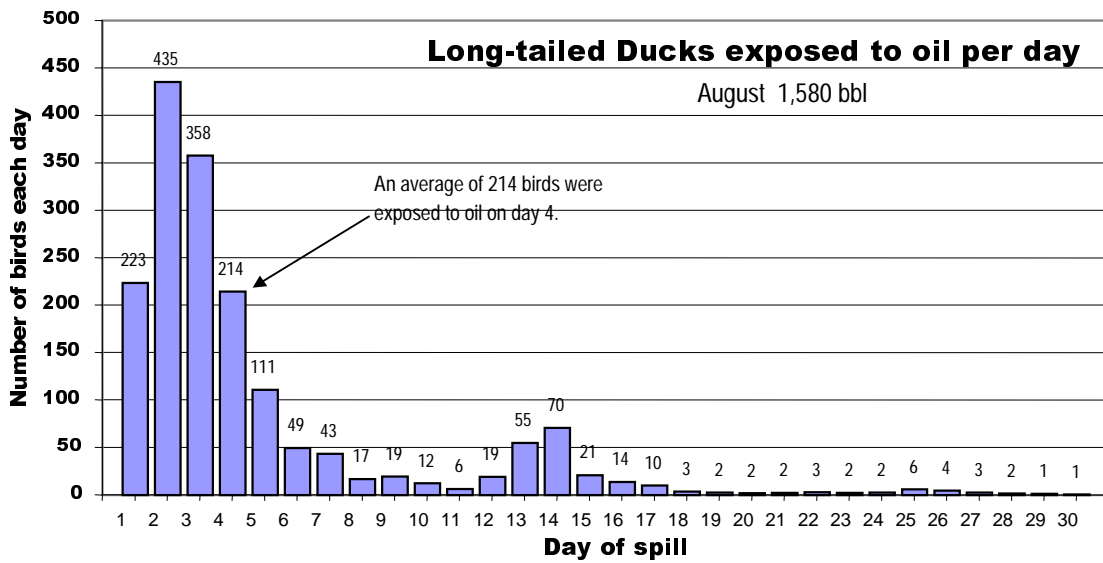
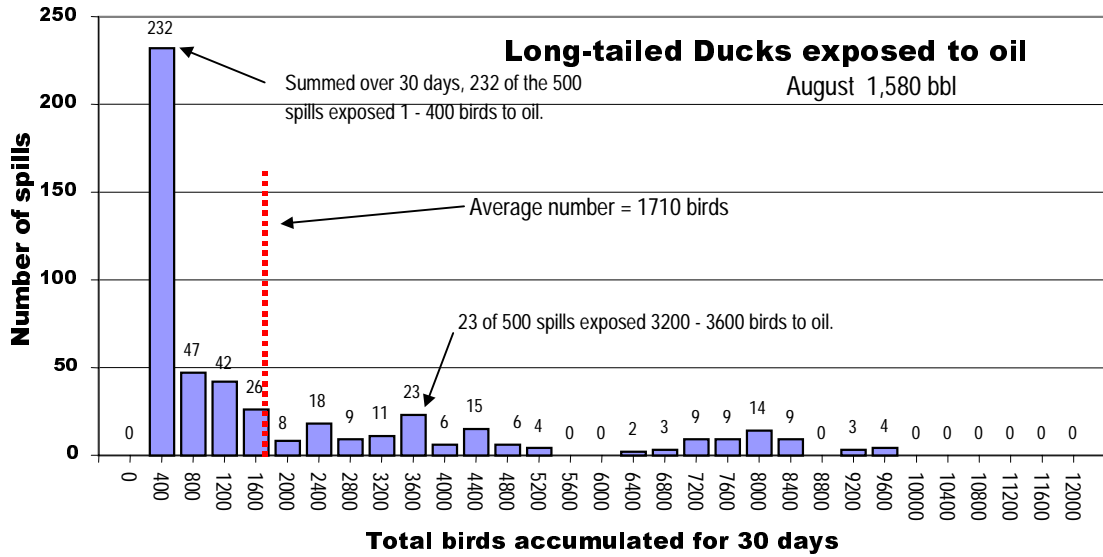

Figure 36. Number of long-tailed ducks exposed in 500 trajectories of 1580-barrel spills in August.

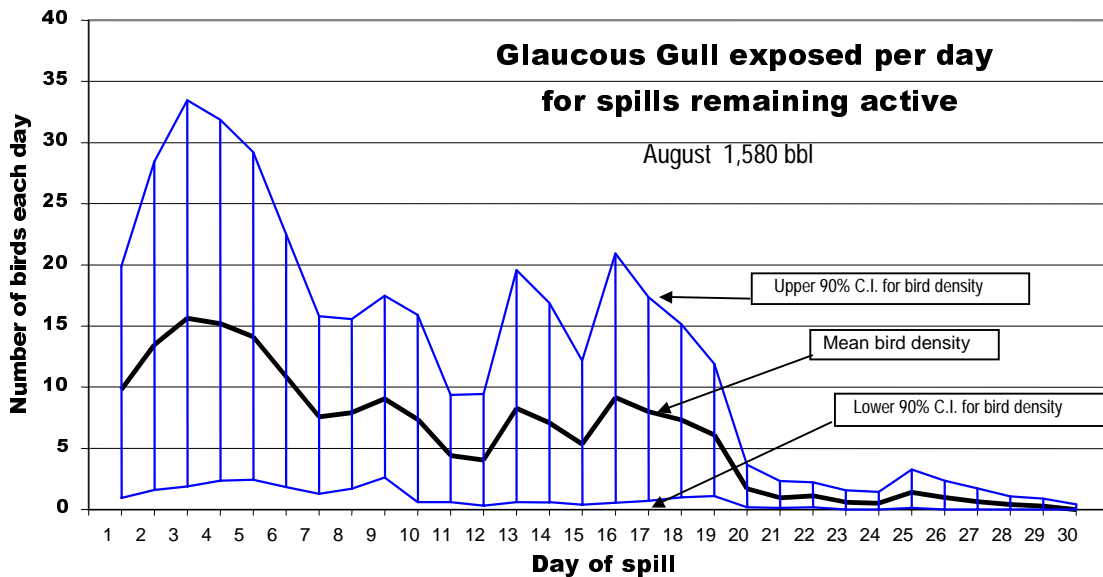
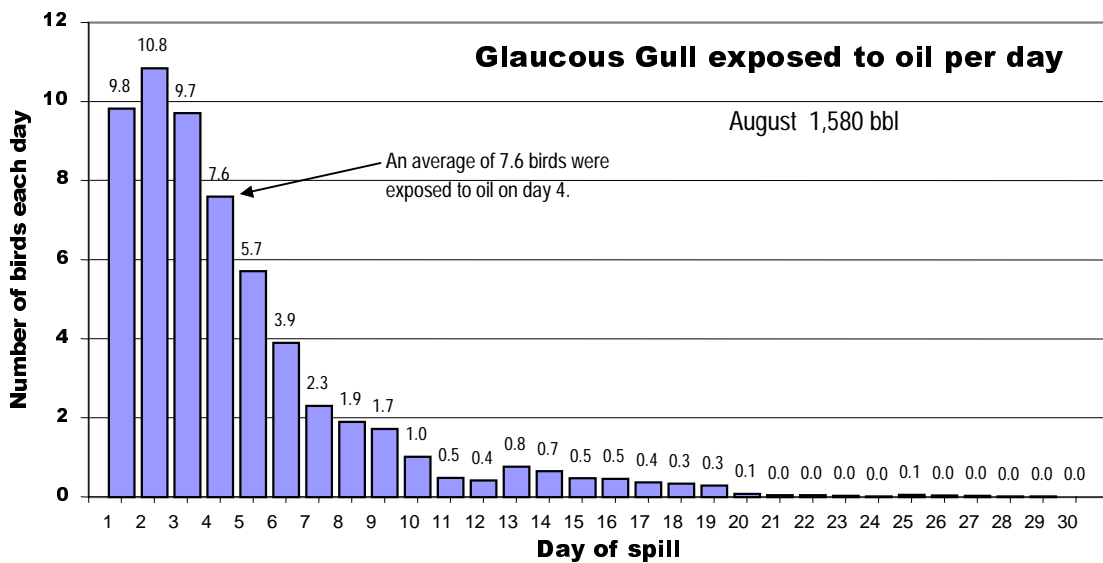
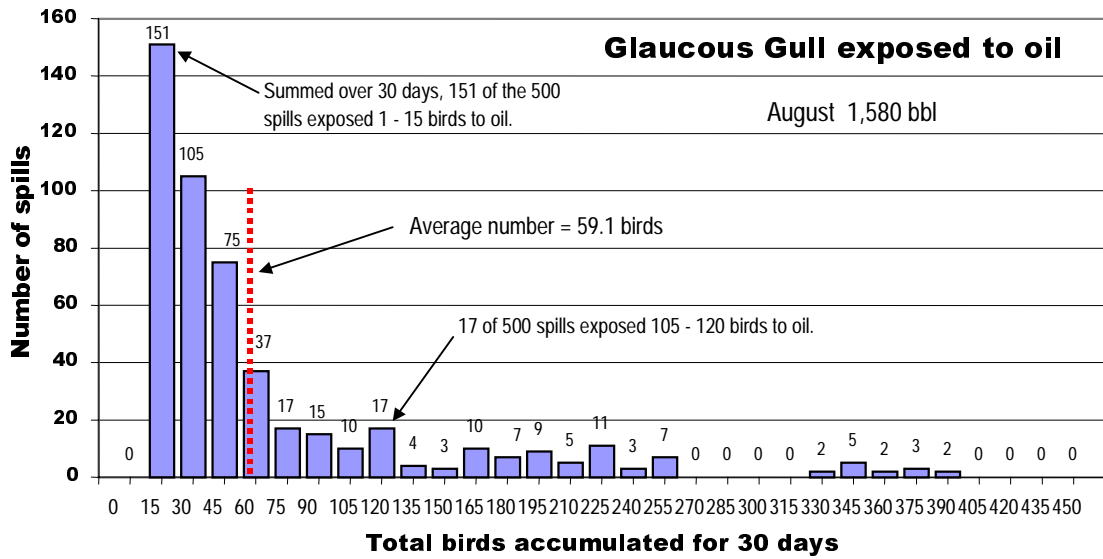

Figure 37. Number of glaucous gulls exposed in 500 trajectories of 1580-barrel spills in August.

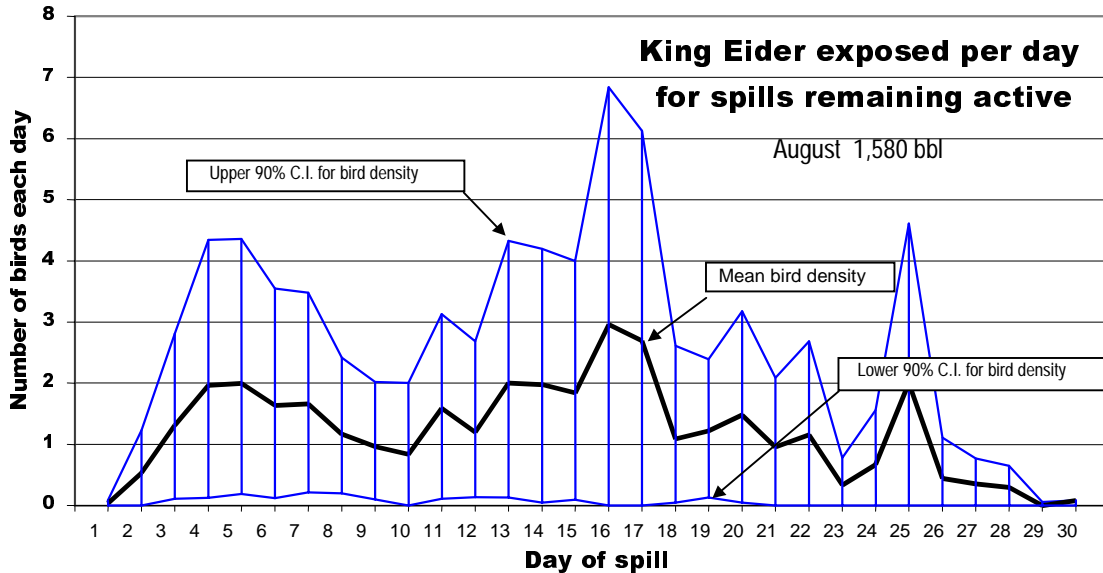
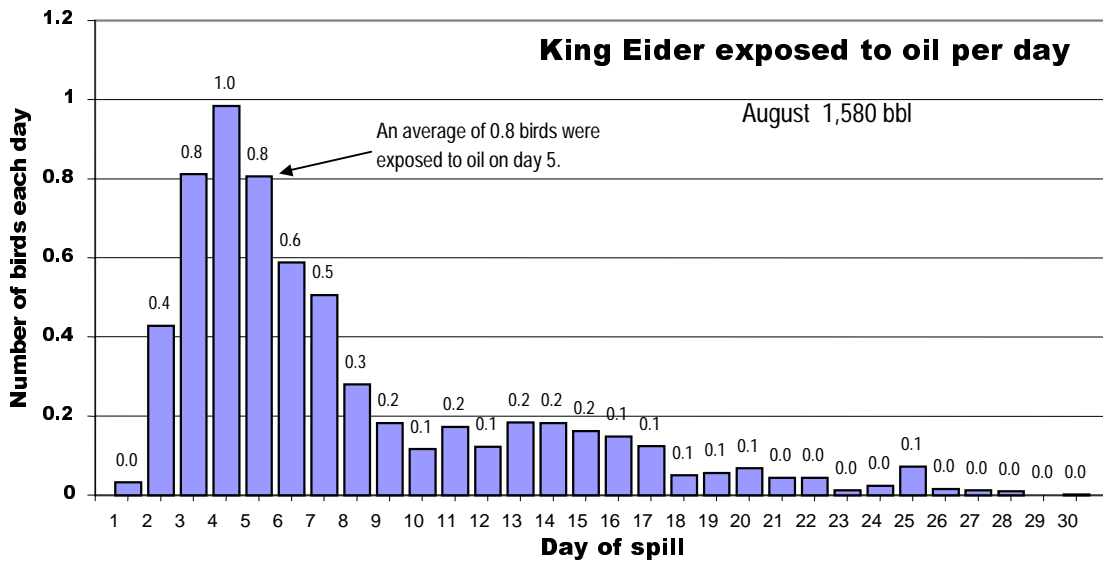
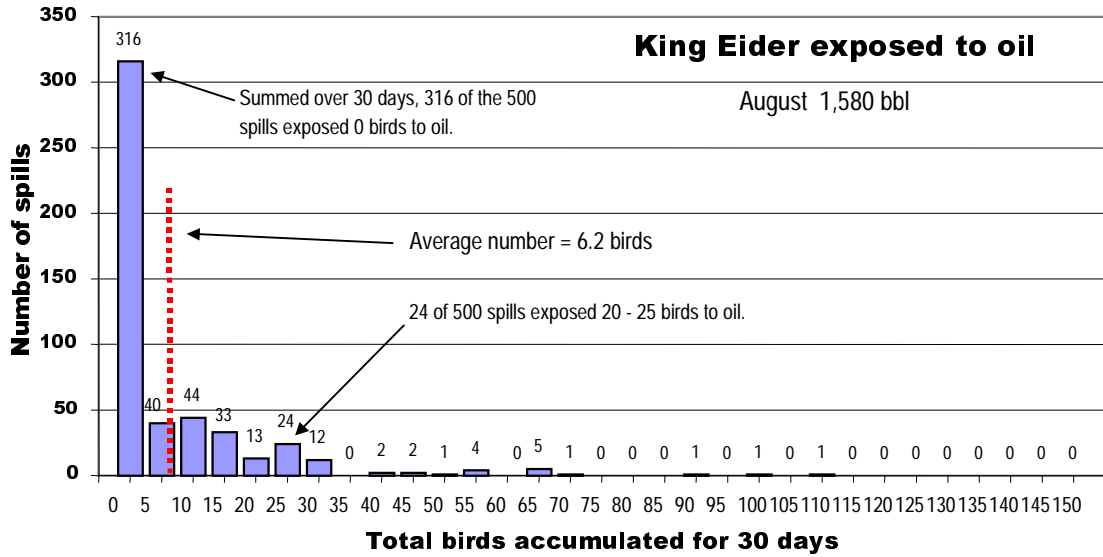

Figure 38. Number of king eider exposed in 500 trajectories of 1580-barrel spills in August.

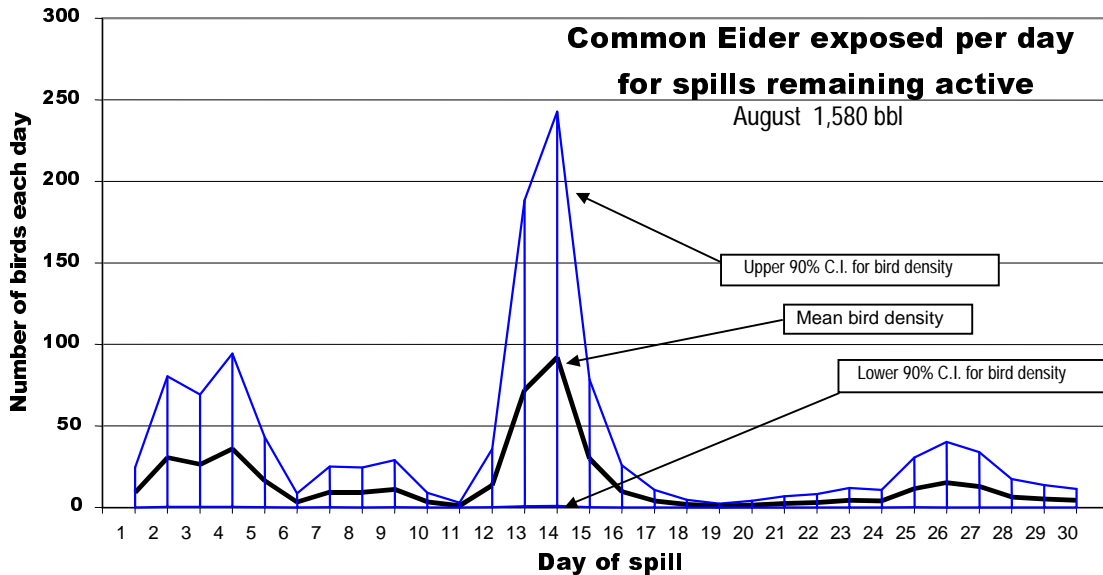
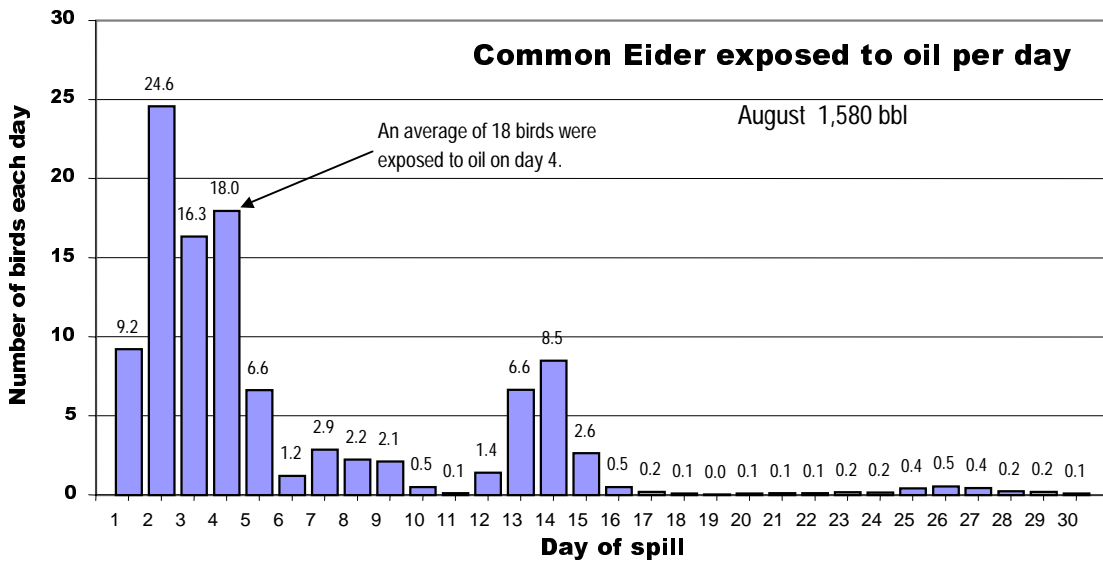
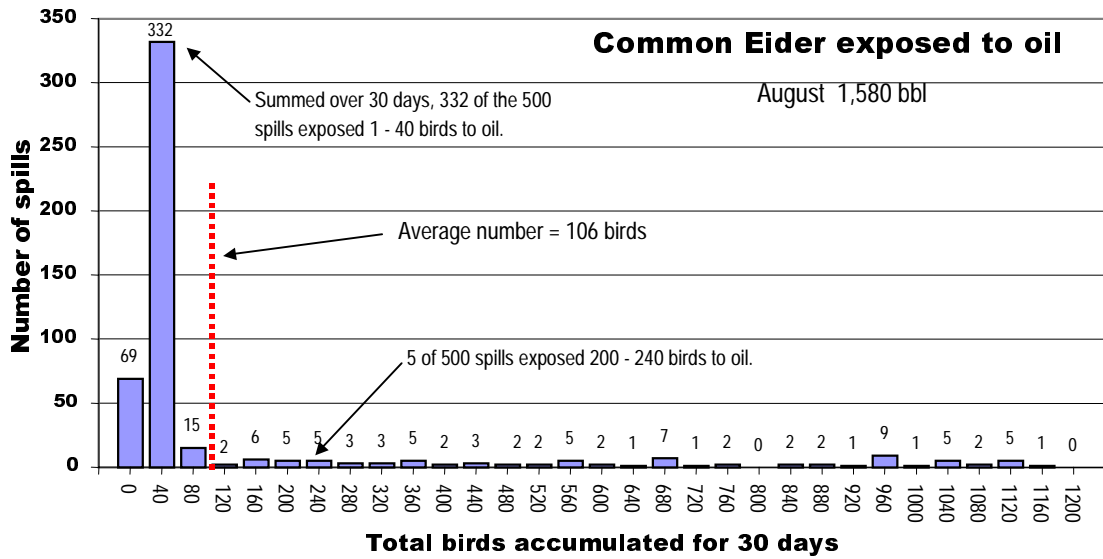

Figure 39. Number of common eider exposed in 500 trajectories of 1580-barrel spills in August.

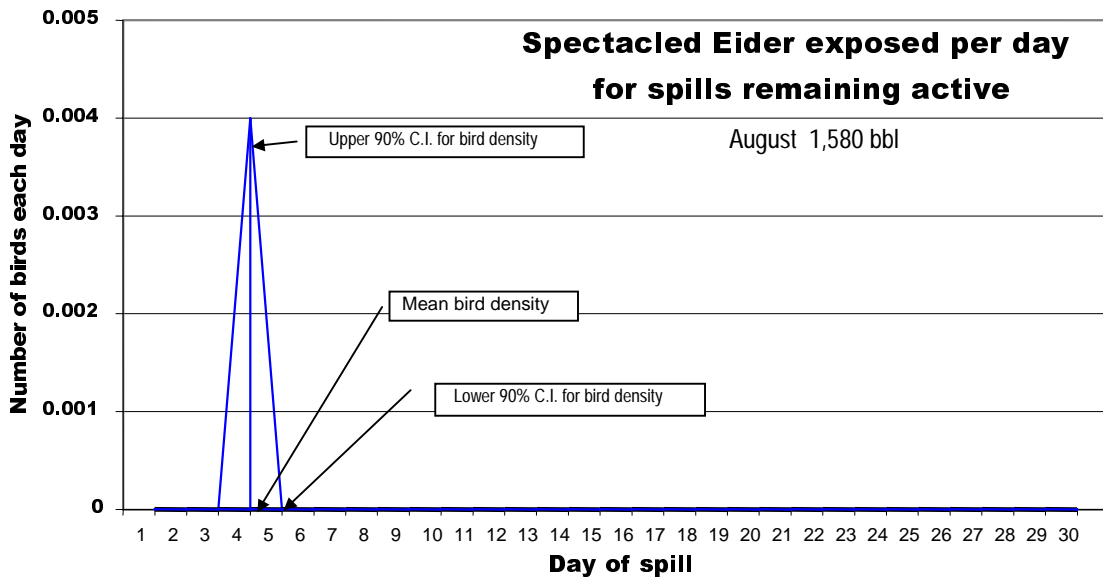
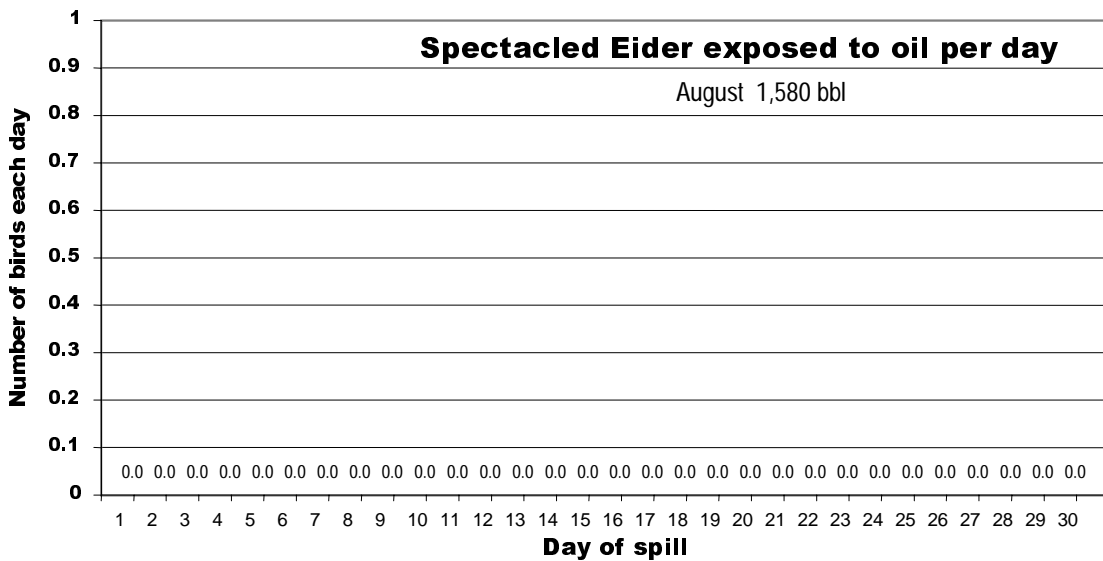
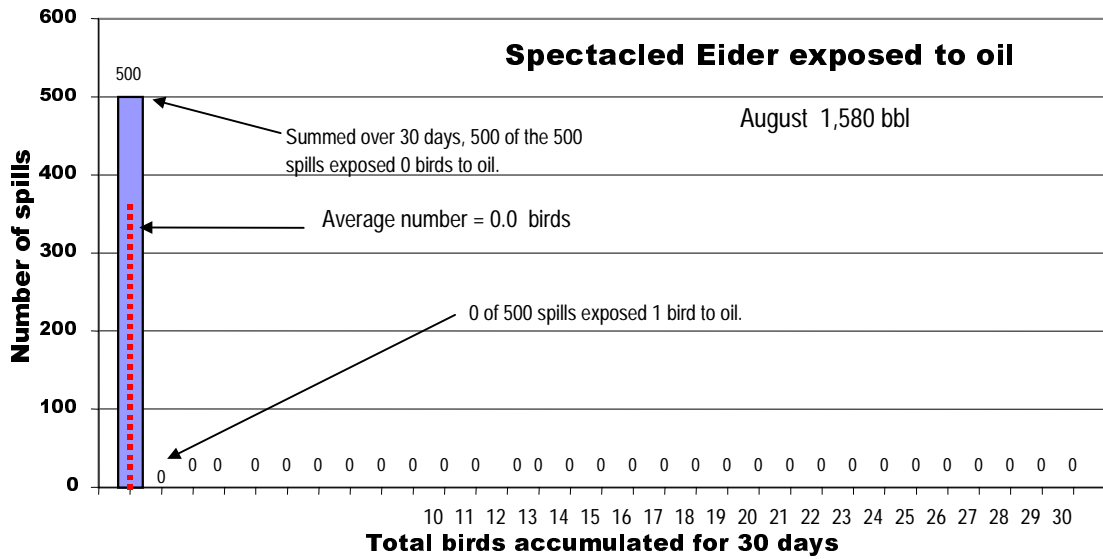

Figure 40. Number of spectacled eider exposed in 500 trajectories of 1580-barrel spills in August.

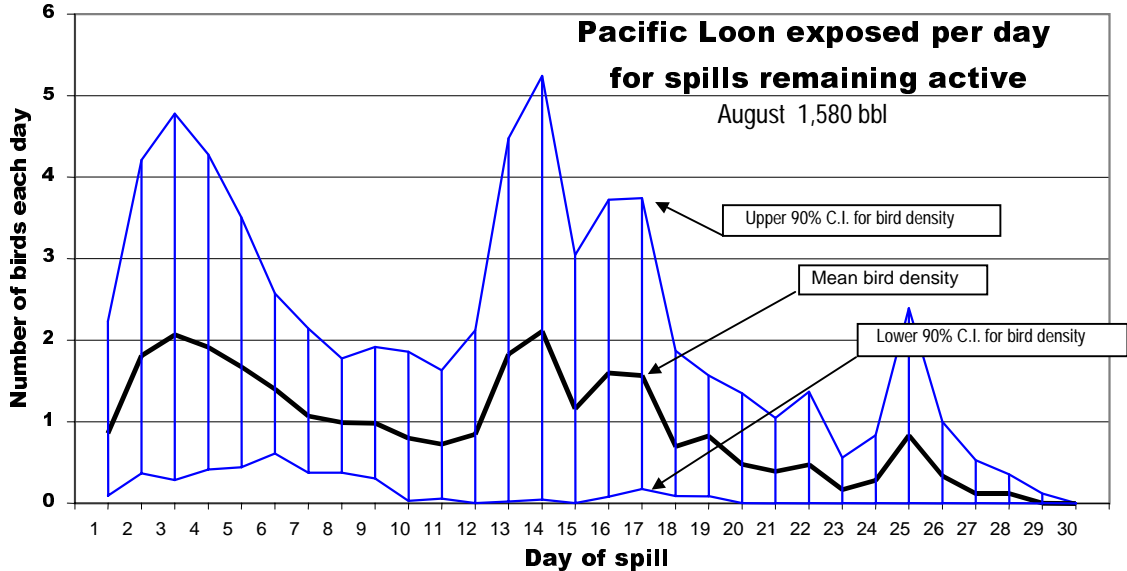
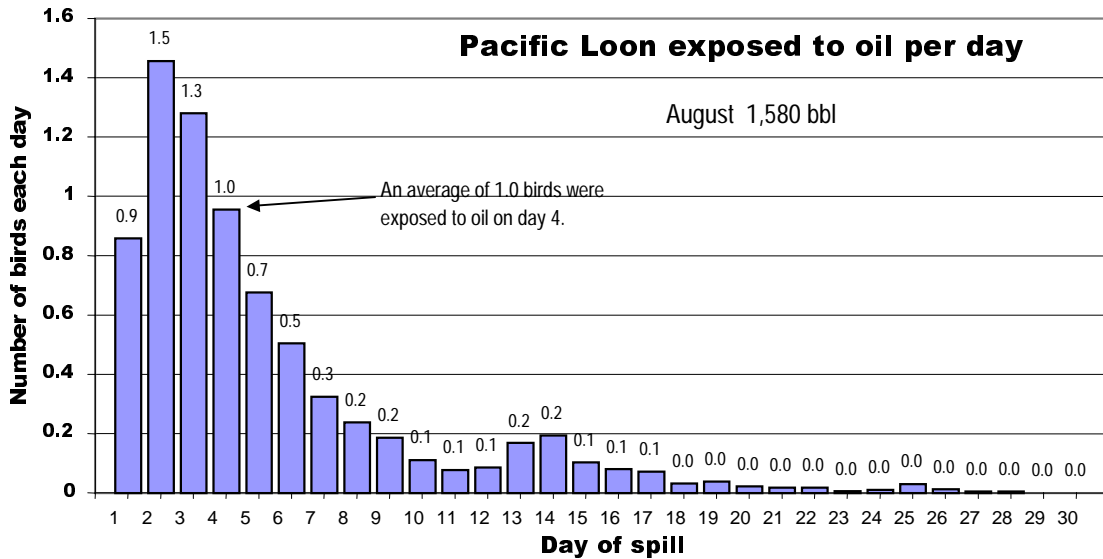
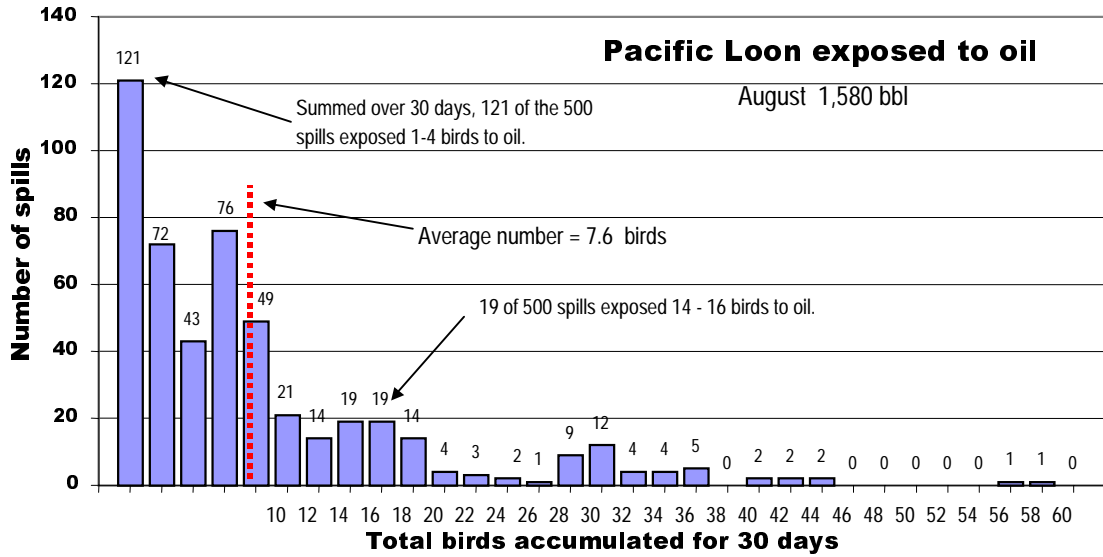

Figure 41. Number of Pacific loons exposed in 500 trajectories of 1580-barrel spills in August.

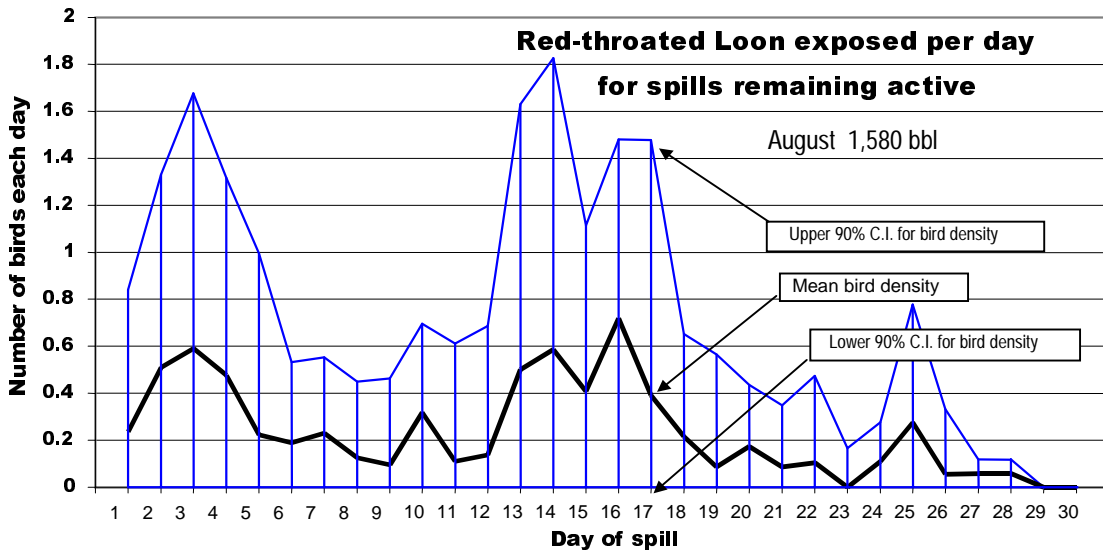
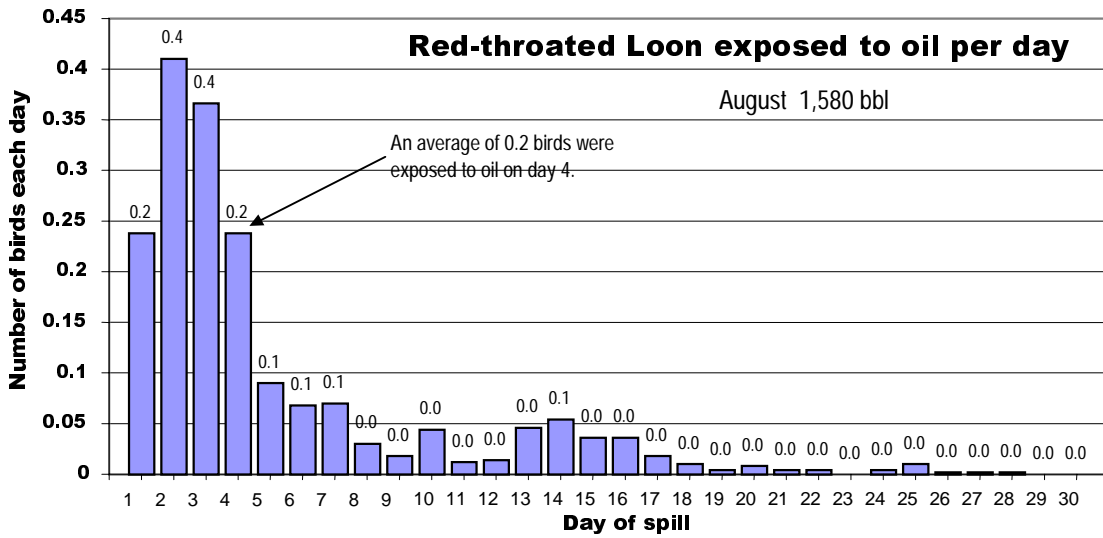
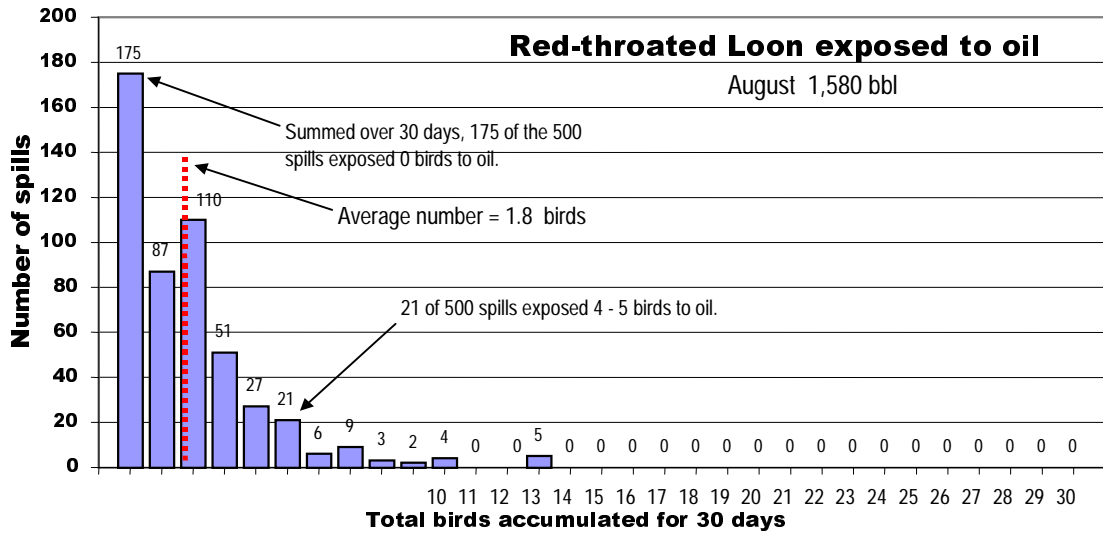

Figure 42. Number of red-throated loons exposed in 500 trajectories of 1580-barrel spills in August.

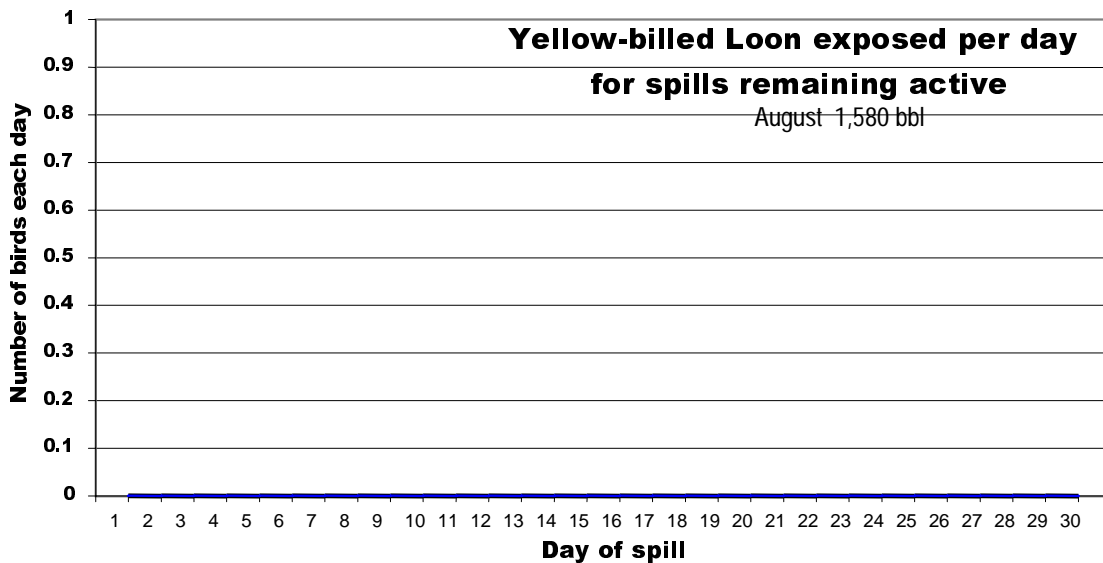
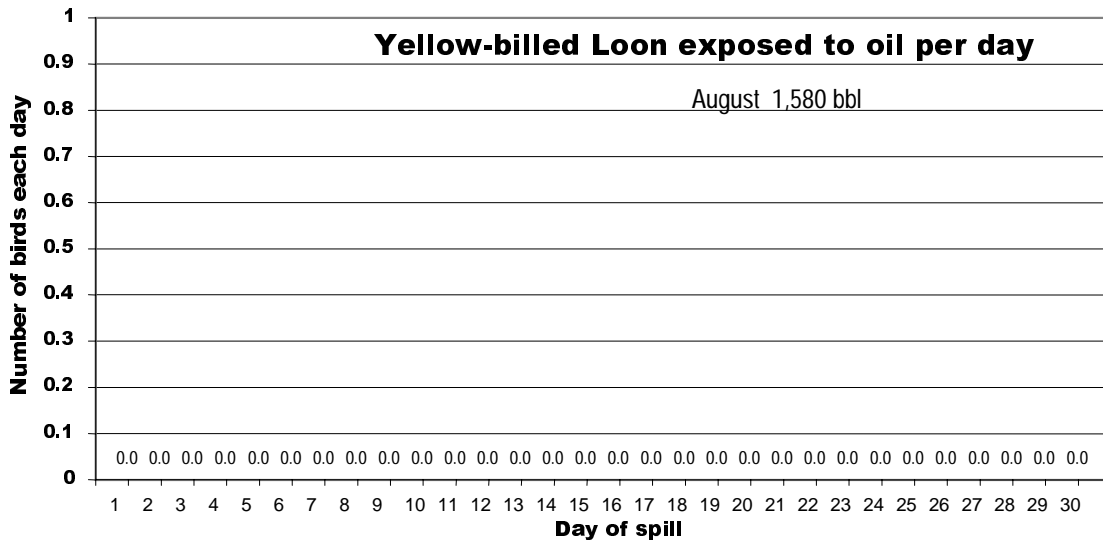
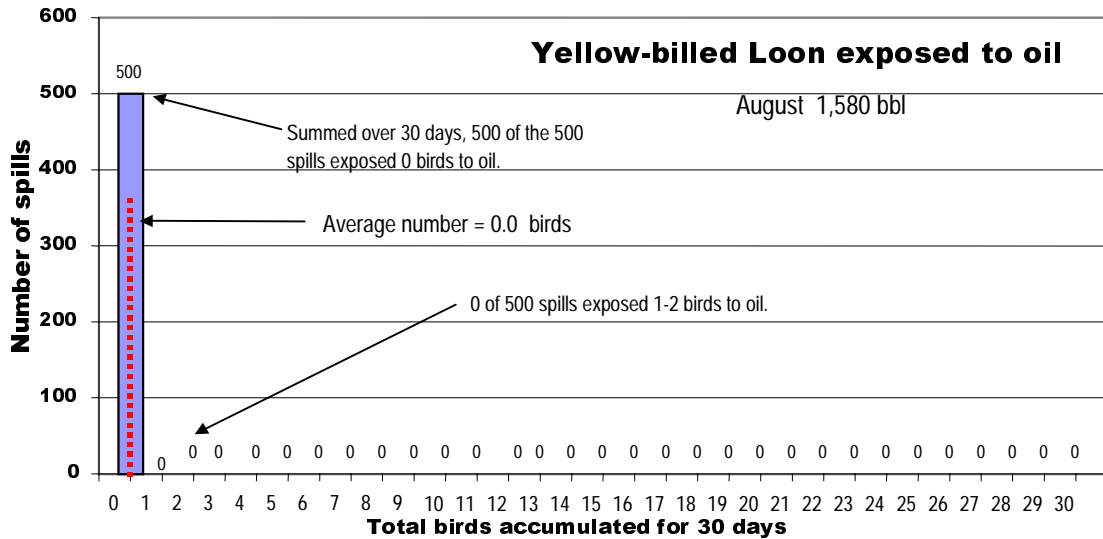

Figure 43. Number of yellow-billed loons exposed in 500 trajectories of 1580-barrel spills in August.

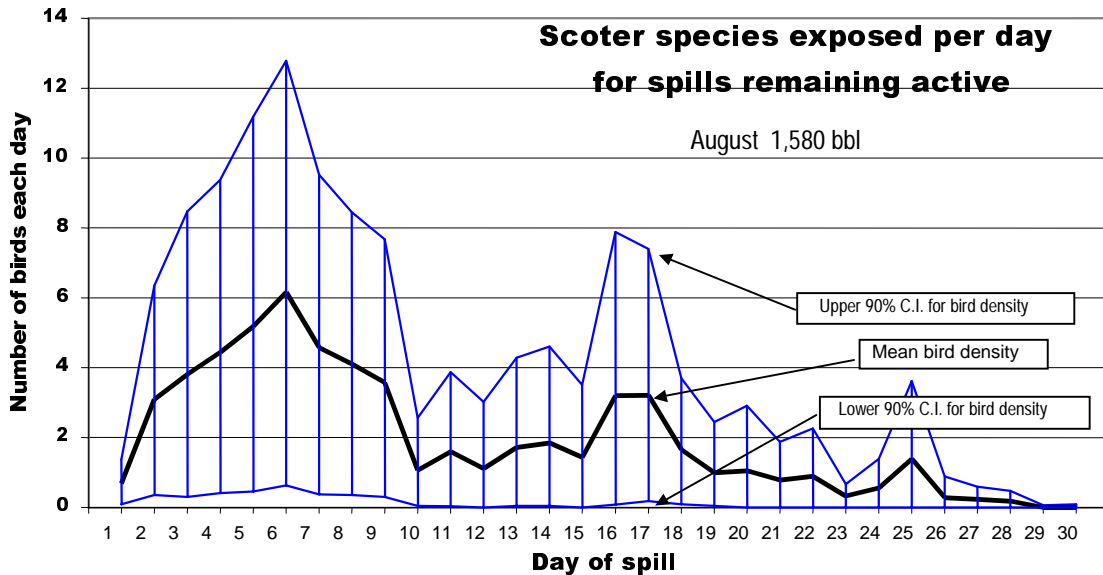
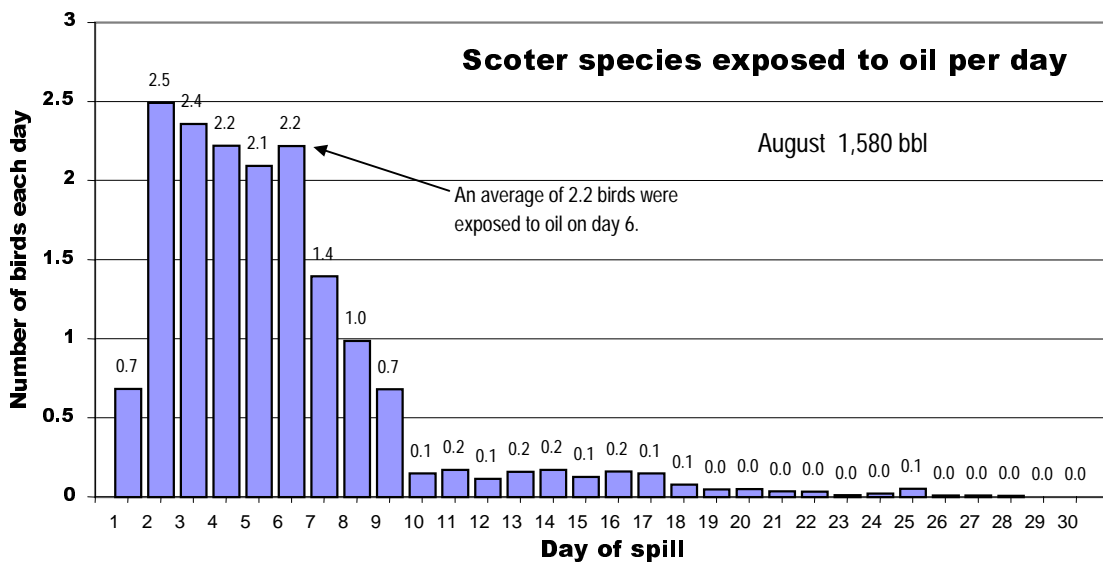
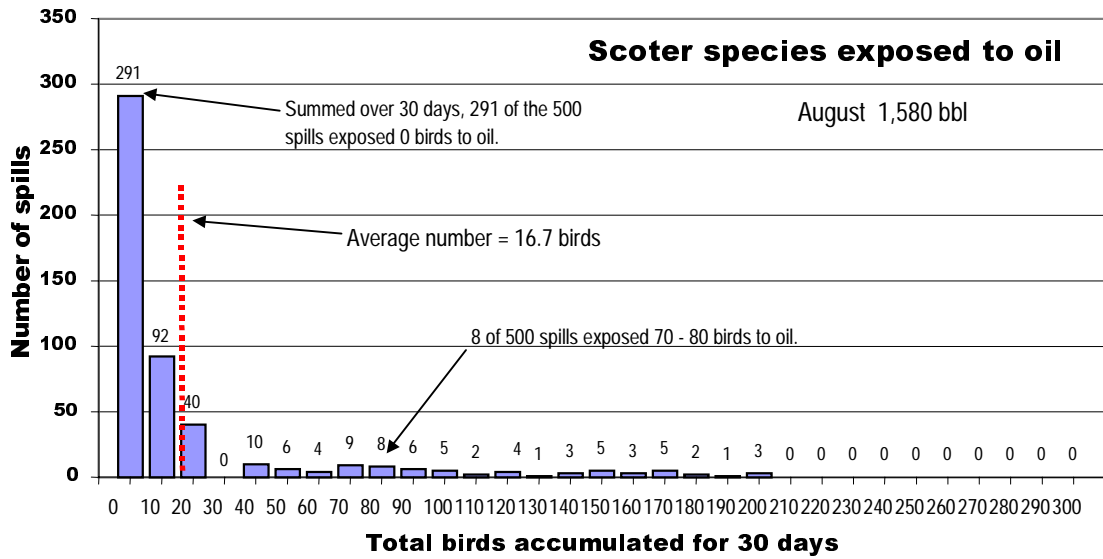

Figure 44. Number of scoters exposed in 500 trajectories of 1580-barrel spills in August.

APPENDIX K

SUMMARY OF EFFECTS OF BPXA'S OIL DISCHARGE PREVENTION AND CONTINGENCY PLAN

Appendix K

Summary of Effects of BPXA's Oil Discharge Prevention and Contingency Plan

by Minerals Management Service, May 18, 2000

Section II.A.4 describes BPXA's Oil Discharge Prevention and Contingency Plan (BPXA, 1999). A revised Oil Discharge Prevention and Contingency Plan was submitted in November 2001 (BPXA, 2001). The plan provides information about the emergency-action checklist, reporting and notification, safety, communications, deployment strategies, response strategies, nonmechanical response options, and prevention plans.

The revised Oil Discharge Prevention and Contingency Plan prohibits the drilling of new wells or sidetracks from existing wells into major liquid-hydrocarbon zones at its drill sites during the defined period of broken ice and open water (BPXA, 2001:Section 2.1.7). This period begins on June 13 of each year and ends with the presence of 18 inches of continuous ice cover for one-half mile in all directions from the Liberty island. This drilling moratorium eliminates the environmental effects associated with a well blowout during drilling operations in the Beaufort Sea during broken-ice or open-water conditions.

The MMS has identified the following sources of potential oil spills greater than or equal to 500 barrels that could effect the marine environment (Table III.C-4):

- blowouts from downhole operations, including drilling development wells from Liberty Island;
- offshore and onshore pipeline leaks and ruptures; and
- diesel oil spills from storage tanks on Liberty Island.

The discharge prevention and contingency plan includes four scenarios that outline the equipment, response tactics, and logistics necessary to clean up these volumes of oil under different environmental conditions—open water, solid ice, and broken ice.

1. Blowout during open-water conditions (180,000 barrels)
2. Blowout during freezeup broken-ice conditions (180,000 barrels)

3. Chronic pipeline leak under solid ice (2,956 barrels)
4. Pipeline leak during broken ice (1,580 barrels)

We evaluate scenarios 1 and 2 in Section IX and scenarios 3 and 4 in Section III.C.2. The scenarios describe a set of specific response tactics (a description of how oil would be contained and recovered) that would be used. Each scenario identifies probable tactics based on a specific type and number of systems that include containment boom(s), oil skimmers, and vessels needed to contain and recover a specific volume of oil. More than 100 specific tactics are detailed in Volume 1 of the Alaska Clean Seas Technical Manual. These tactics include open water, solid ice (both over and under), broken ice (freezeup and breakup), the shoreline, and onshore cleanup and recovery. The tactics also address the storage, tracking and surveillance, in situ burning of oil, shoreline cleanup, wildlife and sensitive area response, disposal, and logistics.

The following information is presented as a summary document of detailed analyses provided in Sections III.C.2 and IX.A. The reader is encouraged to go to those sections for additional analyses and references.

We acknowledge that arctic conditions, particularly in broken ice, are challenging, and that the effectiveness of cleanup capability would depend on actual conditions at the time of the spills. The S.L. Ross study, *Evaluation of Cleanup Capabilities for Large Blowout Spills in the Alaskan Beaufort Sea During Periods of Broken Ice* (S.L. Ross Environmental Research Ltd., D.F. Dickens and Associates, Ltd., and Vaudrey and Associates Ltd., 1998) concluded that cleanup of an oil spill from a blowout ranged from about 10% to more than 45%, depending on ice conditions. Historically, the amount of oil removed from the environment ranges between 5% and 15%. Under ideal conditions, cleanup could achieve a reduction in the spill volume of from 74-99%. (S.L. Ross Environmental

Research Ltd., D.F. Dickens and Associates, Ltd., and Vaudrey and Associates Ltd., 1998).

The oil-spill-contingency plan includes Regional Contingency Field Maps which indicate locations of sensitive resources. This information will assist the Federal On-Scene Coordinator in prioritizing actions and deploying the response team and equipment. The use of this information can help mitigate effects of an oil spill to all of the resources that use or inhabit sensitive areas.

BPXA has revised their oil-spill-contingency plan to more accurately reflect recovery efficiencies in breakup and freezeup ice conditions borne out in the spring and fall 2000 broken-ice barge trials. The analysis presented in this section is based on recovery rates presented in the revised spill contingency plan.

The following sections summarize the environmental effects associated with removing spilled oil from the environment using the combined response strategies identified in the scenario above. A summary of the potential mitigation provided by each spill also is provided.

a. Threatened and Endangered Species

(1) Bowhead Whales

If cleanup activities associated with a very large blowout spill occurred in the fall during the bowhead whale migration, some bowheads would be temporarily displaced from the area by the large number of people and equipment working in the area and from the noise they would generate. For a large blowout spill, cleanup could occur for multiple seasons. If a spill of 2,956-barrels or less occurred during freezeup or solid-ice conditions, some of the oil could be gathered up or removed. It also is likely that cleanup activities in open water would be completed before the bowhead whale migration in the fall. Response efforts during open water or broken ice are directed at keeping oil from getting through the barrier islands to the area where the bowheads migrate. If these tactics are successful, little or no oil would contact the bowhead whales. However, the actual effectiveness of the cleanup effort would be constrained by the weather, wind, wave, and ice conditions (environmental conditions) and by equipment failure or human error. If the cleanup efforts are only partially successful, which is the most likely scenario, the amount of the oil in the water would be reduced, and that would be beneficial to bowheads. If the cleanup activities occurred near coastal areas or onshore, the displacement effect to bowheads (noise and disturbances) would be less. If cleanup activities occurred near the barrier islands or near the whale migration route, the displacement effect to the bowheads would be greater.

The cleanup and removal of oil from the environment would mitigate or lessen the effects of an oil spill to bowhead

whales, but environmental conditions during cleanup may limit the effectiveness of the cleanup.

(2) Eiders

If an oil spill occurred during open water, the most effective response tactic for eiders would be hazing. If a blowout spill occurred, recovery and containment effects would involve hundreds of workers and numerous vessels and aircraft. Their presence would act as a general hazing factor, displacing any eiders in the immediate area, perhaps even a few kilometers. If a reliable system of locating birds in specific areas can be devised, eiders or groups of birds in danger of oil contact could be targeted with specific hazing tactics. Spectacled eiders apparently spend little time in nearshore coastal habitats. However, displacement of females with broods from coastal habitats by cleanup activities or hazing would have a negative effect, if the activities prematurely force the eiders into the offshore marine environment. Otherwise, any effects of coastal cleanup are expected to be minimal.

Cleanup activities during broken ice may be less effective in removing the oil than cleanup in open water, although the possible area covered by a spill may be smaller. Spectacled eiders are not expected to occupy areas of broken ice, because most arriving spring migrants occupy overflow areas near river mouths. Cleanup activities that prevent oil from entering those areas would be most beneficial to the eiders. When the eiders return to the marine environment following breeding, the oil would have weathered, and the oil mousse becomes a minor hazard.

b. Seals and Polar Bears

Cleanup would displace some seals and polar bears from oiled areas and could temporarily stress others. The effects could occur for 1 or 2 years; however, we do not expect the cleanup to affect seal and polar bear behavior and movement beyond the area oiled by the spill or after cleanup. Removing of oiled animal carcasses and hazing of wildlife away from the oil spill could reduce the effects on polar bears. Such hazing may have to be repeated, and poor weather conditions could prevent or limit the effectiveness of this tactic.

The oil cleanup would reduce the level of effects to seals and polar bears, but poor weather and remote conditions may limit the effectiveness of cleanup.

c. Marine and Coastal Birds

Hazing birds to keep them away from an oil spill is an important tactic, regardless of the size of the spill. Containment, recovery, and cleanup activities for a large spill are expected to involve hundreds of workers and numerous boats, aircraft, and onshore vehicles operating

over an extensive area for more than 1 year. The presence of such a workforce is likely to act as a general hazing factor. Cleanup of a smaller spill would require fewer workers for a shorter period and typically disturb fewer birds.

Species occurring in the Liberty area vary considerably in their use of marine habitats, resulting in varying vulnerability to cleanup activities. Molting birds may be adversely affected if they cannot molt on a normal schedule or if they were displaced to inferior habitats. Displacement of female waterfowl with broods from coastal habitats by cleanup activity may have a negative effect if it prematurely forces them into the offshore marine environment, where foraging may be more difficult for the ducklings and other stresses may increase. Disturbance of nesting sea ducks by onshore cleanup activities is not expected to significantly affect their productivity. Helicopter support traffic and human presence probably would be the most disturbing factors associated with oil-spill-cleanup activity. During the nesting season, early June to early September, an effort should be made to route air traffic over areas where there is a low probability of waterfowl nesting, and spill-cleanup personnel should not enter inland areas except on established roads. Lesser snow geese nesting on Howe Island, and brant nesting in colonies along the coast, and both species broodrearing in coastal habitats, are likely to be disturbed by summer cleanup activity in nearby areas.

Prompt containment and removal of oil from offshore areas, accompanied by hazing tactics targeting high-use areas, is likely to result in a substantial reduction of sea duck and shorebird mortality from a large blowout oil spill. Cleanup also would decrease the amount of oil available for uptake by bottom-dwelling organisms that are the principal food of sea ducks and shorebirds. This could reduce the potential for oil uptake by these species, and associated adverse physiological side effects, although the benefit of this indirect effect on their populations is likely to be minor. Removal of oiled bird carcasses from beaches would eliminate a source of oiling for scavengers such as glaucous gulls and common ravens.

If a spill occurred in broken ice, the area covered would be smaller than in open water, and cleanup and containment are likely to be less effective. Most bird species are not expected to occupy areas of broken ice, unless substantial open water areas are available. Most arriving spring migrants likely would occupy overflow areas off river mouths, because those are available earlier and are near nesting areas. Cleanup and containment tactics that focus on preventing oil from entering the overflow areas would be beneficial. By the time birds begin re-entering the marine environment after breeding, the oil would have weathered and the threat of oiling is reduced. Few waterfowl and shorebirds are likely to be present beyond late September, and oil present in broken ice at this time is not expected to represent a hazard; cleanup activity at this time is not expected to disturb significant numbers of individuals.

d. Terrestrial Mammals

Some of the oil from a blowout spill is likely to oil the coastal habitats occupied by herds of caribou and muskoxen. Cleanup operations would displace some caribou, muskoxen, grizzly bears, and foxes. These activities are not expected to affect the behavior and overall movements of these populations. In situ burning could help reduce risks of oil contacting the coastal habitats. Cleanup operations could contribute to the oil damage to shorelines and intertidal areas. The formation of ice during freezeup and solid-ice conditions may reduce the amount of oil that would reach coastal habitats.

The removal of oil from the environment would reduce the level of effects to terrestrial mammals, but poor weather and remote conditions may limit the effectiveness of cleanup.

e. Lower Trophic-Level Organisms

The Alaska Clean Seas technical manual identifies sensitive sections of the Beaufort Sea, including the most sensitive types of shoreline, such as river deltas and sheltered lagoons. These areas are listed as “areas of major concern.” Exclusion booms would be used along the shoreline in marshes and inlets. Deflection booms would be used to divert oil to sections of the coastline that are less sensitive; the oil would be collected by booms and pumped by skimmers to local storage tanks. The shorelines that might be contaminated, as a result of diversionary booming, would be flushed to remove oil from the shore zone.

Spill-response tactics that would use mechanical tilling for aeration and remediation of shoreline sediments might affect the biota. Spill responses that use chemicals on oiled shorelines would affect biota. Spill responses that involve in situ burning would affect shoreline biota, especially on relatively dry shorelines. The tactics for chemical treatments include warnings to avoid chemical use on cobble shorelines where there could be deep penetration, which would help to mitigate impacts. However, all of the shoreline tactics noted above would need the approval of the unified command group for the response. Use of dispersants on a spill near the Boulder Patch could mix the oil further down into the water column and could affect the kelp community. However, the use of dispersants is not essential to the discharge prevention and contingency plan (BPXA, 1999) for Liberty, and their use would require further approval by the Coast Guard.

f. Fishes and Essential Fish Habitat

(1) Fishes

Oil-spill-cleanup activities, whether on ice or for oil entrained in the ice, are not expected to adversely affect fish populations.

Reducing the amount of oil in the marine environment is expected to help mitigate the effects of an oil spill to fish, but the effectiveness of cleanup may be limited by the weather conditions.

(2) Essential Fish Habitat

Salmon are not expected to be measurably affected by oil-spill-cleanup activities. Salmon essential fish habitat in the Liberty area could be adversely affected by cleanup activities. Essential fish habitat adjacent to oiled beaches could be degraded if mechanical tilling of beaches, for aeration and remediation, or high-pressure hot-water washing of beaches lead to loss, and/or potentially delayed recovery, of associated plants. Water quality adjacent to oiled beaches could be degraded, if applications to beaches of chemical cleaners such as COREXIT 9580, fertilizer/surfactant cleaners such as Inipol, or dispersants such as COREXIT 7664 result in dispersion of dissolved hydrocarbons or chemicals into the water column. Various fish species that serve as potential prey for salmon could be displaced from important habitat due to behavioral avoidance of disturbed areas associated with barriers, cleanup equipment, cleanup vessels, or personnel. Use of dispersants in open water near the Boulder Patch could cause hydrocarbons to disperse throughout the water column and lead to negative effects on the associated kelp community and dependent fish.

g. Vegetation-Wetland Habitats

Some of the oil from a large blowout spill could oil wetland saltmarshes along the coast of Foggy Island Bay during the open-water season. Cleanup operations could remove some the oil from the gravel shoreline. However, cleanup of oiled saltmarsh areas would be difficult. Some mechanical and chemical tactics, if employed, could lead to erosion or adversely impact the biota. The effectiveness of the oil-spill cleanup would be determined by the ability of the cleanup efforts to prevent the oil from reaching the coastal areas. Some tactics, such as booming areas and in situ burning, would be more effective, but they may be limited by poor weather and remote conditions. For a large blowout spill, oil contamination of saltmarshes is likely to persist for years. The formation of ice during freezeup and solid-ice conditions is expected to reduce the amount of oil that could reach the coastal wetlands.

The removal of oil from the environment would reduce the level of effects to vegetation-wetland habitats, but poor

weather and remote conditions may limit the effectiveness of cleanup.

h. Subsistence-Harvest Patterns

Disturbance to bowhead whales, seals, polar bears, caribou, fish, and birds potentially could increase from oil-spill-cleanup activities. Offshore, skimmers, workboats, barges, aircraft overflights, and in situ burning during cleanup temporarily could displace offshore resources. Such displacement could cause some animals, including seals in ice-covered or broken-ice conditions, to avoid areas where they normally are harvested or to become more wary and difficult to harvest. Nearshore, people and boats; and onshore, people, support vehicles, heavy equipment, as well as the intentional hazing and capture of animals could disturb coastal resource habitat, displace subsistence species, alter or reduce subsistence hunter access to these species, and alter or extend the normal subsistence hunt. Spill cleanup would reduce the amount of spilled oil in the environment and tend to mitigate spill effects. Potential effects to subsistence resources from cleanup activities would be greater during open-water and broken-ice conditions than during freezeup and solid-ice conditions. Far from providing mitigation, oil-spill-cleanup activities more likely should be viewed as an additional impact, potentially causing displacement of subsistence resources and hunters (see Impacts Assessment, Inc., 1998).

i. Sociocultural Systems

Oil-spill employment associated with response and cleanup could disrupt subsistence-harvest activities for at least an entire season and disrupt some institutions and sociocultural systems. Most likely, it would not displace institutions. If a large blowout spill contacted and extensively oiled coastal habitats, the presence of hundreds of humans, boats, and aircraft would displace subsistence species and alter or reduce access to these species by subsistence hunters. Employment generated to cleanup a spill of 125-2, 956 barrels could be 30-125 cleanup workers (see Economy, Section III.C.2.k). The sudden employment increase could have sudden and significant effects, including inflation and displacement of Native residents from their normal subsistence-harvest activities by employing them as spill workers. Cleanup is unlikely to add population to the communities, because administrators and workers would live in separate enclaves; however, cleanup employment of local Inupiat could alter normal subsistence practices and put stresses on local village infrastructures by drawing local workers away from village service jobs. A decline in the certainty about the safety of subsistence foods, potential displacement of subsistence resources and hunters, and changes in sharing and visiting could lead to a loss of community solidarity. Far from providing mitigation, oil-

spill-cleanup activities more likely should be viewed as an additional impact, causing displacement and employment disruptions (see Impact Assessment, Inc., 1998).

j. Archaeological Resources

The greatest effects to onshore archaeological sites would be from cleanup activities resulting from accidental oil spills. The most important understanding from past cleanups of large oil spills is that the spilled oil usually did not directly affect archaeological resources (Bittner, 1993). The State University of New York at Binghamton evaluated the extent of petrochemical contamination of archaeological sites as a result of the *Exxon Valdez* oil spill (Dekin, 1993). Researchers concluded that the three main types of damage to archaeological deposits were oiling, vandalism, and erosion, but fewer than 3% of the resources would suffer significant effects.

k. Economy

In the event of a very large oil spill (180,000-barrels), the subsequent cleanup would generate approximately 3,000 jobs for 1-2 years, declining to zero by the third year following the spill. Employment generated to clean up a possible 125-2,956-barrel oil spill is estimated to be 30-125 cleanup workers for 6 months in the first year, declining to zero by the third year following the spill. Long-term economic effects would be minimal.

l. Water Quality

Oil-spill-cleanup activities are not expected to affect water quality by adding any new or additional substances to the water. Removing oil from the environment would help reduce the amount of oil that gets dispersed into the water. However, the amount of oil removed depends on environmental conditions during cleanup operations. As the oil is removed, the amount contributing oil to dispersion decreases and, as the oil is dispersed, the concentration decreases. The effect of removing oil would be to reduce the concentration in the water relative to the amounts estimated in the above analysis for a given time interval or given area.

m. Air Quality

Cleanup of a very large oil spill would require the operation of some equipment, such as boats and vehicles. Emissions from their operation would include nitrogen oxides, carbon monoxide, and sulphur dioxide. Also, if some of the spilled oil should be burned, the burning would release pollutants. Soot is the major contributor to pollution from a fire or in

situ burning. This soot, which would cling to plants near the fire, would tend to slump and wash off vegetation in subsequent rains, limiting any health effects. We expect accidental emissions to have little effect on onshore air quality.

n. Environmental Justice

Alaska Inupiat Natives, a recognized minority, are the predominant residents of the North Slope Borough, the area potentially most affected by Liberty development. Effects on Inupiat Natives could occur because of their reliance on subsistence foods, and Liberty development may affect subsistence resources and harvest practices. Potential effects would be experienced by the Inupiat community of Nuiqsut, and possibly Kaktovik, within the North Slope Borough. In the unlikely event that a large oil spill occurred and contaminated essential whaling areas, major effects could occur when impacts from contamination of the shoreline, tainting concerns, cleanup disturbance, and disruption of subsistence practices are factored together. However, effects are not expected from routine activities and operations. When we consider the little effect from routine activities and the low likelihood of a large spill event (the chance of one or more large spills [greater than or equal to 500 barrels] occurring and entering offshore waters is low, on the order of 1% over the life of the field), disproportionately high adverse effects would not be expected on Alaskan Natives from Liberty development under the Proposal. Any potential effects on subsistence resources and subsistence harvests are expected to be mitigated substantially, though not eliminated.

APPENDIX L

DRAFT EIS COMMENTERS

Table L-1 Providers of Written Comments on the Liberty DEIS

Comment Number	Comment Method	Comment Name	Comment Number	Comment Method	Comment Name
0001	E-mail	Joe Ray Skrha	0053	E-mail	Joe Mickey
0002	E-mail	David M. Rose	0054	E-mail	Myron Hudson
0003	E-mail	Bruce Hiscock	0055	E-mail	Andrew Lao
0004	E-mail	Carole R. Keene	0056	E-mail	David and Diane Sonnevile
0005	E-mail	Mr. & Mrs, J. L. Denison	0057	E-mail	J.D. Nethery
0006	E-mail	Bruce Connery	0058	Letter	Lori Roy
0007	E-mail	Sergio Monteiro	0059	E-mail	Elaine Galariada
0008	E-mail	Alice (Ajax) Eastman	0060	E-mail	Helen Venada
0009	E-mail	Pamela Woolum	0061	E-mail	Amanda Morten
0010	Letter	Theresa N. Obermeyer	0062	E-mail	William L. Risser
0011	Letter	Russell Heath	0063	E-mail	Melissa Cruz
0012	E-mail	Alicia LaFuente	0064	E-mail	Soren Gormley
0013	Letter	Jenny Pursell	0065	E-mail	Betsy Bowen
0014	Letter	P. Adler	0066	E-mail	Sherry Lizardo
0015	Letter	Tony Verzone	0067	E-mail	Melinda Hall
0016	E-mail	Anne Dougherty	0068	E-mail	Emily Schuster
0017	E-mail	Tom Dussek	0069	E-mail	Tony Munster
0018	E-mail	Jim Nethery	0070	E-mail	Jeff Braden
0019	E-mail	Patricia E. Riley	0071	E-mail	Carol Grosser
0020	E-mail	Corinne Smith	0072	E-mail	?
0021	E-mail	Sampo Tukianinen	0073	E-mail	Janet Payne
0022	E-mail	Kristin Marsh	0074	E-mail	Kara Gelinis
0023	E-mail	Clair Mortimer	0075	E-mail	Debra Sincere
0024	E-mail	Michael Buhr	0076	E-mail	Walter Lee
0025	E-mail	Helen Ross	0077	Letter	Sarah Jensen
0026	E-mail	Patrick Boyne	0078	Letter	Carla M. Blackford
0027	E-mail	Chris Peers	0079	E-mail	Dustyn Cornell
0028	E-mail	Kara Gelinis	0080	E-mail	Melissa Osband
0029	E-mail	Michael Jay	0081	E-mail	Jerome Etzler
0030	E-mail	Thomas Trocone	0082	E-mail	Cheshire Frager
0031	E-mail	Daniel Clark	0083	E-mail	Julie Sylvestre
0032	E-mail	Kimberly Couch	0084	E-mail	Jennifer Manning
0033	E-mail	Pilar Ozbakan	0085	E-mail	Barry Krayser
0034	E-mail	Kristen Bartlett	0086	E-mail	Jennifer Kosminskas
0035	E-mail	Arlen Comfort	0087	E-mail	Howard Holt
0036	E-mail	Desiree Iturbide	0088	E-mail	Jessica Ollis
0037	E-mail	Ben Phalan	0089	E-mail	Linda Ciulla
0038	E-mail	Deborah Hill	0090	E-mail	Joan Summers
0039	E-mail	Sandy Smith	0091	E-mail	Colleen Guy
0040	E-mail	Jesse Trotter	0092	E-mail	Pablo Sahad
0041	E-mail	Shawn Shaw	0093	E-mail	Terry Bunch
0042	E-mail	Andrew Lao	0094	E-mail	Athena Hoven
0043	E-mail	Guy Germain	0095	E-mail	Kristen Bartlett
0044	E-mail	Chris Plante	0096	E-mail	Joyce Dean
0045	E-mail	Mina Hinson	0097	E-mail	Norman Holy
0046	E-mail	Karen Birkner	0098	E-mail	Beth Porterfield
0047	E-mail	Riley	0099	E-mail	Mary Laura Calhoun
0048	E-mail	Debra Sincere	0100	E-mail	Mary Graves
0049	E-mail	Walter Lee	0101	E-mail	Judy Reed
0050	E-mail	Janet Chafe	0102	E-mail	Jan Smith
0051	E-mail	Jan Smith	0103	E-mail	Lorrie Crawford
0052	E-mail	Sara Leibovich	0104	E-mail	Lisa Widawsky

Table L-1 Providers of Written Comments on the Liberty DEIS (continued)

Comment Number	Comment Method	Comment Name
0105	E-mail	James Khedari
0106	E-mail	Frances Perlman
0107	E-mail	Frances Cone
0108	E-mail	Pilar Ozbakan
0109	E-mail	Tetty Gorfine
0110	E-mail	Don Gauthier
0111	E-mail	Gary Herring
0112	E-mail	CJ Moran
0113	E-mail	John Quinn
0114	E-mail	Arlen Comfort
0115	E-mail	Debra Hughson
0116	E-mail	Peter Gan
0117	E-mail	Lucille Ann York
0118	E-mail	Rosemarie Stremmlau
0119	E-mail	Kathy Baxter
0120	E-mail	Charles Sack
0121	E-mail	Barbara LeBrossie
0122	E-mail	Janet Chafe
0123	E-mail	Maija Dravnieks
0124	E-mail	Tye Eyden
0125	E-mail	Dave Hood
0126	E-mail	Margaret Fennell
0127	E-mail	Sara Markwith
0128	E-mail	Ken Dawdy
0129	E-mail	Michael Wald
0130	Letter	Alaska Eskimo Whaling Commission
0131	Letter	North Star Terminal & Stevedore Co.
0132	Letter	North Slope Borough
0133	Letter	Department of the Army, U.S. Army Engineer District, Alaska
0134	Letter	U.S. Department of Commerce, National Oceanic and Atmospheric Administration, National Marine Fisheries Service
0135	Letter	*Trustees for Alaska
0136	Letter	BP Exploration (Alaska) Inc.
0137	Letter	State of Alaska
0138	Letter	Deidre Zoll
0139	Letter	U.S. Fish and Wildlife Service
0140	Letter	Michael Mayo
0141	Letter	Environmental Protection Agency
0142	E-mail	Jen Crowley
0143	E-mail	Joanna Burton
0144	Letter	U.S. Department of Transportation, Research and Special Programs Administration Office of Pipeline Safety, Western Region
0145	Letter	Barrow Whaling Captains Association
0146	Letter	Inupiat Community of the Arctic Slope
0147	Letter	City of Barrow
0148	Letter	U.S. Department of Transportation, U.S. Coast Guard, Waterways Management Directorate

* Alaska Center for the Environment, Alaska Community Action on Toxics, Alaska Conservation alliance, Alaska wilderness League, Center for Biological Diversity, Defenders of Wildlife, Greenpeace, National Wildlife Federation, Natural Resources Defense council, Northern Alaska Environmental Center, Sierra Club, The Wilderness Society

Table L-2 Providers of Oral Testimony on the Liberty DEIS

Barrow Public Hearing

Mr. Eugene Brower
Mr. Edward Itta
Ms. Maggie Ahmaogak
Mayor Jim Vorderstrasse
Mr. Charles Hopson
Mr. Arnold Brower, Jr.
Mr. Fred S. Kanayurak
Mr. Ronald Brower, Sr.
Mr. Forrest D. Olemann
Mr. Bill Tegoseak
Mr. Gordon Brower
Ms. Vera Williams
Mr. Frederick Tukle, Sr.
Mr. Archie Ahkiviana (Excerpt as Read by Ms. Maggie Ahmaogak)
Mr. Arnold Brower, Sr.
Mr. Cash Fay

Kaktovik Public Hearing

Mayor Lon Sonsalla
Mr. Cash Fay
Mr. Loren Ahlers
Mr. Issac Akootchook
Ms. Merylin Traynor

Nuiqsut Public Hearing

Mr. Noah Itta
Mr. Johnny Ahtuanaruk
Mr. Archie Ahkiviana
Mayor Eli Nukapigak
Mr. Cash Fay
Mr. Leonard Lampe
Mr. James Taalak
Ms. Rosemary Ahtuanaruk
Mr. Mark Helmericks

Anchorage Public Hearing

Ms. Theresa Obermeyer
Ms. Jenna App

Fairbanks Public Hearing

Ms. Deb Moore
Mr. Michael Wald
Mr. Phil Wildfang
Ms. Mary Shields
Ms. Judy Kreith

APPENDIX M

**FEDERAL,
STATE,
AND
LOCAL
PERMITS
AND
AUTHORIZATIONS**

Table M.1 - Federal, State, and Local Permits and/or Approvals for Development and Production of the Liberty Project

Regulatory Agency	Permit/Approval Requirements
Minerals Management Service	<ul style="list-style-type: none"> • Reviews and approves a Development and Production Plan of operations under Section 11& 25 of the OSCLA • Reviews and approves Pipeline Right-of -Way on Federal OCS • Reviews and approves Platform Verification and Pipeline Verification • Reviews and approves the Oil Discharge Prevention and Contingency Plan and Certificate of Financial Responsibility
U.S. Army Corps of Engineers	<ul style="list-style-type: none"> • Issues a Section 404 permit under the Clean Water Act of 1997, as amended for discharge of dredged an fill material into U.S. waters, including wetlands • Issues a Section 10 permit under the Rivers and Harbors Act of 1899 for structures or work in, or affecting, navigable waters of the US. • Issues a Section 103 Ocean Dumping permit under Section 103 of the Marine Protection, Research, and Sanctuaries Act of 1972 (MPRSA) for the transport of dredged material for ocean disposal
U.S. Environmental Protection Agency	<ul style="list-style-type: none"> • Issues a National Pollutant Discharge and Elimination System (NPDES), fact sheet, and Ocean Discharge Criteria Evaluation under Section 402, Federal Water Pollution Control Act of 1972, as amended, for discharges in the marine environment • Issues an Air Quality Permit under Section 309 of the Clean Air Act • Requires a Spill Prevention, Containment, and Countermeasure Plan to be developed by the owner and operator • Reviews and must concur with COE MPRSA finds and decision or makes an independent permit decision.
U.S. Fish and Wildlife Service	<ul style="list-style-type: none"> • Endangered Species Act Consultation under Section 7(a)(2) of the Endangered Species Act of 1973, for effects to threatened or endangered species • Issues a Letter of Authorization under the Marine Mammal Protection Act for incidental takes of marine mammals under USFWS jurisdiction • Issues incidental Harassment Authorization under the MMPA for incidental takes of marine mammals under USFWS jurisdiction
National Marine Fisheries Service	<ul style="list-style-type: none"> • Endangered Species Act Consultation under Section 7(a)(2) of the Endangered Species Act of 1973, for effects to threatened or endangered species • Issues a Letter of Authorization under the Marine Mammal Protection Act for incidental takes of marine mammals under NMFS jurisdiction • Issues incidental Harassment Authorization under the MMPA for incidental takes of marine mammals under NMFS jurisdiction • Essential Fish Habitat consultation
North Slope Borough	<ul style="list-style-type: none"> • Rezoning and Master Plan Revision/Statement of Conformance for project development and construction activities related to onshore pipeline, valve pads, and mine site • Coastal Zone Consistency Determination under the Coastal Zone Management Act of 1972, as amended, A.S. 46.40 Alaska Coastal Management Program, 1977; Borough Ordinance 90-39, to address project planing of development within the coastal zone.
State of Alaska - Division of Governmental Coordination	<ul style="list-style-type: none"> • Conducts a Coastal Zone Consistency review under the Coastal Zone Management Act of 1972, as amended, A.S. 46.40 Alaska Coastal Management Program, 1977; 6 AAC 50 and concurs or doesn't concur with BPXA Consistency Analysis and Certification.

Regulatory Agency	Permit/Approval Requirements
State of Alaska - State Pipeline Coordinator's Office	<ul style="list-style-type: none"> Issues pipeline right-of-way leases for pipeline construction and operation across State lands under AS 38.35.020
State of Alaska - Department of Natural Resources, Division of Mining, Land, and Waters	<ul style="list-style-type: none"> Issues a material Sales Contract under AS 38.05.850; for mining and purchase of gravel from state lands Issues land use permits under AS 38.05.850 for use of state land, ice road construction on state land, and state freshwater bodies Issues a Temporary Water Use Permit or Water Rights authorization under AS 46.15 for water necessary for construction and operation
State of Alaska - Department of Fish and Game	<ul style="list-style-type: none"> Issues a Fish Habitat Permit for Kadleroshilik River (and any river crossing) under AS 16.05.840 (Fishway Act) and AS 16.05.870 (Anadromous Fish Act).
State of Alaska - Division Environmental Conservation	<ul style="list-style-type: none"> Reviews and approves Oil Discharge Prevention and Response Contingency Plan (directly applicable to portions of the pipeline in State waters and on land; applicable through the Coastal Zone Consistency process for facilities in Federal waters). Issues Clean Water Act Section 401 certifications for wastewater discharge and fill activities in State waters or in wetlands. Reviews and approves, through the Coastal Zone Consistency process, wastewater discharges, air emissions, and other actions in Federal waters that may affect Alaska's air, land, and water. Issues short-term variance to water quality standards in State waters. Issues or certifies a permit to allow deposit of substances on the bottom of State marine waters. Issues approval for water quality mixing zones in State waters. Reviews and approves plans for the treatment of wastewater in Alaska. Issues permits for the discharge of wastewater in State waters or on land.
State of Alaska - Department of Natural Resources, State Historic Preservation Office	<ul style="list-style-type: none"> Issues a Cultural Resources Concurrence under the National Historic Preservation Act of 1966, as amended, AS 41.35.010 to .240, Alaska Historic Preservation Act, for developments that may affect historic or archaeological sites.

Table M.2 - Liberty Approval Matrix

Approval Needed for	Primary Agencies Involved	Permits /Authorization	Other Agency Involvement	Timing/Comments
Island Location and Design	1. MMS	1. Reviews and Approves DPP - Platform Verification and determination of conservation of resources		1. MMS reviews and approves the DPP under Sections 11 and 25 of the OCSLA. Requires NEPA Review, independent engineering review, and geologic evaluation.
	2. COE	2. COE Section 10 Work and Structure in Navigable Waters		2. Requires NEPA Review. Permit issued subsequent to FEIS issuance.
Pipeline Route and Design	1. MMS	1. Approval of OCS ROW		1. Requires NEPA and Independent Engineering Review (Joint effort with JPO)
	2. State JPO/DNR	2. Approval of State ROW		2. Requires Engineering Review (Joint Effort with MMS)
	3. COE	3. COE Section 404 Backfill, Section 10 Work in Navigable Waters, and Section 103 Dredging / Ocean Dumping Permit (MPRSA)	3. COE Decision can be elevated by EPA and FWS	3. Requires NEPA Review
	4. EPA	4. EPA must concur with COE MPRSA or make independent decision		4. Requires NEPA and Subsequent Agency Review
	5. DOT	5. US DOT Reviews Design, issues and enforces regulations (49CFR 195)		5. Requires NEPA Review and Subsequent Agency Review
Gravel Source	1. COE	1. COE 404 Backfill		1. Requires NEPA Review. Permit issued subsequent to FEIS issuance.
	2. State DNR	2. Gravel Material Sale		2. Required Public Notice and Issuance of Material Sale Contract
Air Quality	EPA	Air Quality Permit		Needs NEPA Review and Air Emission Modeling. Air modeling work has been completed. Permit can be issued subsequent to FEIS filing with EPA.
NPDES	EPA	NPDES Waste Water and Storm Water Permit		Needs NEPA Review and modeling. Modeling work has been completed. Permits can be issued subsequent to FEIS issuance.

Table M.2 - Liberty Approval Matrix (continued)

Approval Needed for	Primary Agencies Involved	Permits /Authorization	Other Agency Involvement	Timing/Comments
Incidental Take of Whales & Seals	NMFS	LOA		Needs NEPA Review / NMFS is not a cooperating agency and may do a separate environmental analysis. <ul style="list-style-type: none"> • BPXA will apply for LOA • MMS does not need LOA to approve project
Incidental Take of Polar Bears & Walrus	FWS	IHA		Needs NEPA Review / FWS is not a cooperating agency and may do a separate environmental analysis. <ul style="list-style-type: none"> • BPXA will apply for IHA • MMS does not need IHA to approve project
Biological Opinion (BO)	1. FWS (Eiders)	1. Biological Opinion	1. MMS and BPXA can participate in review of draft BO	MMS cannot issue a decision without BO's. BA's were issued in late February. BO should be available by preliminary FEIS.
	2. NMFS (Bowheads) with participation of NSB	2. Biological Opinion	2. MMS and BPXA can participate in review of draft BO	
Consistency Certification	State DGC, with participation of other agencies and the North Slope Borough	State must concur with consistency certification before MMS decision and before State Permits can be issued		BPXA prepares Consistency Analysis and Certification. It appears State wants preliminary FEIS, with agency preferred alternatives, before starting the Consistency process, which can take 180 days. State concurs or doesn't concur. Non-concurrence can be appealed to DOC by BPXA.
BPXA's Oil Spill Contingency Plan	1. MMS	1. MMS Approval	1. MMS reviews and approves plan	1. Needs NEPA Review and is part of the current EIS.
	2. State DGC/DEC	2. State Approval	2. State Approval of Plan needed as part of State's Consistency Findings and for permitting of pipeline on State Land or in State Waters	

Table M.2 - Liberty Approval Matrix (continued)

Approval Needed for	Primary Agencies Involved	Permits /Authorization	Other Agency Involvement	Timing/Comments
State Water Certification	DNR	Permits needed to construct ice roads and onshore activities		MMS does not need permit to approve DPP. Permit needed prior to construction.
State 401 Certificate of Compliance of Water Quality Regs.	DEC	401 Certificate for pipeline on State Land or in State Waters		EPA needs certification before issuing NPDES permit. Permit needed prior to construction
State Land Use Permit	DNR	Permits needed to construct ice roads and onshore activities		MMS does not need permit to approve DPP. Permit needed prior to construction.
NSB Rezoning	NSB Planning Commission and Borough Assembly	Rezoning needed for pipeline construction		Rezoning not needed by MMS to approve project. Rezoning needed by BPXA prior to start of construction.
Response Plans for Pipelines	1. MMS	1. MMS Responsible for all Offshore Pipelines		
	2. DOT	2. DOT is Responsible for all Onshore Pipelines		
Short-term non-point discharges to State waters that do not meet water quality standards	DEC	Short-term variance approval	Coastal zone consistency determination.	
Deposit of substances on the bottom of State marine waters	DEC	1. Issue a zone of deposit permit or 2. Certify COE permit.	COE permit. Coastal zone consistency determination.	
Discharge of wastewater in State waters or on land	DEC	State wastewater discharge permit	EPA, if NPDES permit issued instead. Coastal zone consistency determination.	Depending on the discharge, a general permit may be used or a specific permit may be issued.

Table M.2 - Liberty Approval Matrix (continued)

Approval Needed for	Primary Agencies Involved	Permits /Authorization	Other Agency Involvement	Timing/Comments
<i>Use of a mixing zone to meet Alaska Water Quality Standards</i>	DEC	Mixing zone approval	Coastal zone consistency determination.	Typically incorporated into the discharge permit or the coastal zone consistency determination
<i>Oil Discharge Prevention and Response Plan</i>	1. MMS	1. MMS plan approval	1. MMS reviews and approves plan.	
	2. DEC	2. DEC plan approval	2. DEC reviews and approves plan for portions of the pipeline in State waters and on land.	
	3. DGC/DEC	3. State plan approval	3. State approves plan through coastal zone consistency process for portions of the project in Federal waters that could affect State resources.	



The Department of the Interior Mission

As the Nation's principal conservation agency, the Department of the Interior has responsibility for most of our nationally owned public lands and natural resources. This includes fostering sound use of our land and water resources; protecting our fish, wildlife, and biological diversity; preserving the environmental and cultural values of our national parks and historical places; and providing for the enjoyment of life through outdoor recreation. The Department assesses our energy and mineral resources and works to ensure that their development is in the best interests of all our people by encouraging stewardship and citizen participation in their care. The Department also has a major responsibility for American Indian reservation communities and for people who live in island territories under U.S. administration.



The Minerals Management Service Mission

As a bureau of the Department of the Interior, the Minerals Management Service's (MMS) primary responsibilities are to manage the mineral resources located on the Nation's Outer Continental Shelf (OCS), collect revenue from the Federal OCS and onshore Federal and Indian lands, and distribute those revenues.

Moreover, in working to meet its responsibilities, the **Offshore Minerals Management Program** administers the OCS competitive leasing program and oversees the safe and environmentally sound exploration and production of our Nation's offshore natural gas, oil and other mineral resources. The **MMS Royalty Management Program** meets its responsibilities by ensuring the efficient, timely and accurate collection and disbursement of revenue from mineral leasing and production due to Indian tribes and allottees, States and the U.S. Treasury.

The MMS strives to fulfill its responsibilities through the general guiding principles of: (1) being responsive to the public's concerns and interests by maintaining a dialogue with all potentially affected parties and (2) carrying out its programs with an emphasis on working to enhance the quality of life for all Americans by lending MMS assistance and expertise to economic development and environmental protection.



20 Years of Service to America

MMS

Minerals Management Service

1982-2002