

Seafloor Disturbance and Recovery Monitoring at the Block Island Wind Farm, Rhode Island – Summary Report



Seafloor Disturbance and Recovery Monitoring at the Block Island Wind Farm, Rhode Island – Summary Report

March 2020

Authors (in alphabetical order):
Anwar A. Khan and Kevin Smith

Prepared under BOEM Award
Contract No. M15PC00002
Task Order No. M17PD00015
By
HDR
9781 S Meridian Boulevard, Suite 400
Englewood, CO 80112

**US Department of the Interior
Bureau of Ocean Energy Management
Office of Renewable Energy Programs**

DISCLAIMER

Study concept, oversight, and funding were provided by the U.S. Department of the Interior, Bureau of Ocean Energy Management (BOEM), Environmental Studies Program, Washington, DC, under Contract Number M15PC00002, Task Order Nos. M15PD00031, M16PD00025, and M17PD00015. This report has been reviewed by BOEM and it has been approved for publication. The views and conclusions contained in this document are those of the authors and should not be interpreted as representing the opinions or policies of the U.S. Government, nor does mention of trade names or commercial products constitute endorsement or recommendation for use.

REPORT AVAILABILITY

To download a PDF file of this report, go to the U.S. Department of the Interior, Bureau of Ocean Energy Management [Data and Information Systems webpage](http://www.boem.gov/Environmental-Studies-EnvData/) (<http://www.boem.gov/Environmental-Studies-EnvData/>), click on the link for the Environmental Studies Program Information System (ESPIS), and search on 2020-019. The report is also available at the National Technical Reports Library at <https://ntrl.ntis.gov/NTRL/>.

CITATION

HDR. 2020. Seafloor Disturbance and Recovery Monitoring at the Block Island Wind Farm, Rhode Island – Summary Report. Final Report to the U.S. Department of the Interior, Bureau of Ocean Energy Management, Office of Renewable Energy Programs. OCS Study BOEM 2020-019. 317 pp.

ABOUT THE COVER

Cover photo: Block Island Wind Farm Facility, Turbine 5 foundation installation. Courtesy of HDR RODEO Team. Used with permission. All rights reserved.

ACKNOWLEDGMENTS

The HDR RODEO Team includes the following subcontractors (in alphabetical order):

- Arthur Popper, Ph.D.
- Clark Group, LLC
- EA Engineering Science & Technology, Inc.
- Fugro USA Marine, Inc.
- Fugro GB Marine Ltd.
- H.T. Harvey & Associates
- Loughine Limited
- Subacoustech Environmental

Significant additional technical support for the monitoring effort was provided by the following institutions:

- Marine Acoustics, Inc.
- University of Rhode Island
- Woods Hole Oceanographic Institution
- Blue Land Media

Vessel services for visual monitoring were provided by Hula Charters.

Assistance and support from all team members are greatly appreciated.

Contents

List of Figures (all shown in Appendix B).....	iii
List of Tables.....	iii
List of Abbreviations and Acronyms.....	iv
Editorial Notes.....	iv
Executive Summary	1
1 Introduction	5
1.1 RODEO Program.....	5
1.2 Block Island Wind Farm.....	5
1.3 Report Organization.....	8
2 Seafloor Disturbance and Recovery Assessment	9
2.1 Survey Objectives.....	9
2.2 Survey Area	9
2.3 Survey Frequency.....	9
2.4 Survey Methods.....	11
2.4.1 Surveying	11
2.4.2 Data Processing.....	11
2.4.3 Data Interpretation.....	12
2.4.4 Data Variability and Repeatability	12
2.4.5 Data Quality.....	13
2.5 Survey Results and Discussion	13
2.5.1 Survey 1	13
2.5.2 Survey 2	13
2.5.3 Survey 3	13
2.5.4 Survey 4	17
2.5.5 Survey 5	18
2.6 Characterization of Seafloor Disturbances and Recovery around Individual Turbines	18
2.6.1 Turbine 1	19
2.6.2 Turbine 2	21
2.6.3 Turbine 3	22
2.6.4 Turbine 4	23
2.6.5 Turbine 5	24
2.7 Characterization of Seafloor Disturbances Elsewhere in the Survey Area	24
2.7.1 Seafloor between the Turbines	24

2.7.2	Seafloor along the Cable Trench Routes	25
2.8	Seafloor Recovery Rates	26
2.9	Overview of Spatial Extent of Seafloor Disturbances in the Wind Farm Survey Area	28
3	Scour Assessment	29
3.1	Turbine Foundation Scour Assessment	29
3.1.1	Approach and Methods	29
3.1.2	Results	30
3.1.3	Short-term Trends	30
3.1.4	Long-term Trends.....	30
3.2	Concrete Mat Scour Assessment	31
3.2.1	Approach and Methods	31
3.2.2	Results	31
3.3	Conclusions and Lessons Learned.....	31
4	Seafloor Disturbance and Recovery Monitoring Conclusions	33
5	References.....	35
	Appendix A: Field Plan.....	36
	Appendix B: Figures.....	37
	Appendix C: May 2016 (Survey 1) Bathymetry Survey Technical Report	49
	Appendix D: October 2016 (Survey 2) Bathymetry Survey Technical Report.....	50
	Appendix E: May 2017 (Survey 3) Bathymetry Survey Technical Report	51
	Appendix F: October 2017 (Survey 4) Bathymetry Survey Technical Report	52
	Appendix G: September 2018 (Survey 5) Bathymetry Survey Technical Report.....	53
	Appendix H: Turbine Foundation Scour Assessment Technical Report.....	54

List of Figures (all shown in Appendix B)

Figure 1. Location of BIWF Turbines.	37
Figure 2. BIWF Survey Area.	38
Figure 3. Examples of seafloor disturbance features.	39
Figure 4. Time series from Survey 1 (May 2016) to Survey 5 (September 2018) for each Turbine, depicting seafloor disturbance and recovery.	40
Figure 5. Inter-array cable trench seafloor recovery patterns.....	41
Figure 6. Export and transmission cable trench seafloor recovery patterns.....	42
Figure 7. Interpreted seafloor recovery rates over the five surveys.....	43
Figure 8. Scour monitor in bracketing (top); seafloor frame and AWAC (bottom).	44
Figure 9. Location of deployed equipment.	45
Figure 10. Positioning of the scour monitors on the turbine foundation.	46
Figure 11. Mean scour depth of each beam per month.....	47
Figure 12. Summary mean scour profile.....	48

List of Tables

Table 1. RODEO Program monitoring conducted at the BIWF.	6
Table 2. Seafloor disturbance and recovery monitoring bathymetry survey summary.....	10
Table 3. Comparison of Survey 1 and Survey 2 Results	14
Table 4. Recovery Tracking of Construction Phase 1 Seafloor Disturbance Features	15
Table 5. Recovery Tracking of Construction Phase 2 Seafloor Disturbance Features	16
Table 6. Seafloor Disturbances within 175 m (574 ft) Work Zone of Each Turbine.....	20
Table 7. Summary of Cable Trench area seafloor recovery	26
Table 8. Seafloor recovery per zone.....	28
Table 9. Locations of turbine scour monitoring equipment.	29

List of Abbreviations and Acronyms

ac	acre(s)
ASCII	American Standard Code for Information Interchange
AWAC	acoustic wave and current profiler
BIWF	Block Island Wind Farm
BOEM	Bureau of Ocean Energy Management
cm	centimeter(s)
DTM	digital terrain model
ft	feet
in	inches
km	kilometer(s)
m	meter(s)
m ²	square meter(s)
mi	mile(s)
mm	millimeter(s)
POS MV	Position and Orientation System for Marine Vessels
RODEO	Real-Time Opportunity for Development Environmental Observations
UTM	Universal Transverse Mercator
WGS84	World Geodetic System, 1984
WTG	wind turbine generator

Editorial Notes

- All coordinates used in this report are referenced to World Geodetic System, 1984 (WGS84), unless stated otherwise.
- Current direction is the direction toward which the current is flowing.

Executive Summary

Seafloor disturbance and recovery monitoring were conducted in and around the Block Island Wind Farm (BIWF) to assess the impact of wind farm construction activities on the seafloor. Previous studies from Europe have shown that introduction of solid structures onto the seafloor, such as the four-legged BIWF turbine jacket foundations, can modify near-bottom current flow processes and induce scour. This in turn may temporarily or permanently alter seafloor characteristics. Changes in seafloor characteristics may result in loss of native benthic habitat directly impacting benthic community abundance and diversity. It may possibly also compromise functionality and physical integrity of the structures themselves.

The seafloor can also be affected by several different construction-related activities such as vessel anchoring, life boat legs anchoring, and trenching for laying of submarine power transmission cables. Accordingly, the primary objectives of the seafloor disturbance and recovery monitoring surveys were to identify and characterize seafloor disturbances associated with wind farm construction activities and to monitor recovery times for the different types of disturbance features over time.

This study included developing and field testing a methodology for monitoring seafloor scour around the turbine foundations in real time using innovative scour monitors. Concrete mats were placed on the unburied cable sections for protection. Scour associated with the concrete mats was also evaluated during this monitoring effort.

Data from the seafloor disturbance and recovery monitoring surveys were intended to provide information necessary for the U.S. Department of the Interior Bureau of Ocean Energy Management's (BOEM's) evaluation of environmental effects of future facilities, and to improve the accuracy of models and analysis criteria employed to establish monitoring controls and mitigations. Monitoring and testing were conducted under BOEM's Real-Time Opportunity for Development Environmental Observations (RODEO) Program.

The five-turbine, 30-megawatt BIWF is the nation's first offshore wind facility, and is located 4.5 kilometers (2.8 miles) from Block Island, Rhode Island, in the Atlantic Ocean. Water column depth in the wind farm area is approximately 30 meters (m) (98.4 feet [ft]). BIWF construction was completed in two phases. During Phase 1, five steel jacket foundations were installed on the seafloor. Phase 2 involved installation of the turbines on the foundations and laying of the submarine power transmission cables. Phase 1 construction occurred between 26 July and 26 October 2015, and Phase 2 construction occurred between 13 May and 18 August 2016.

Five rounds of seafloor bathymetry surveys were conducted within a defined construction Work Area from a small research vessel using a Reson SeaBat 7125 ultra-high-resolution multibeam echosounder. The first survey was conducted in May 2016, approximately 7 months after completion of the Phase 1 construction. The second survey was conducted in October 2016, approximately 10 months after completion of Phase 1 construction activities and 2 months after completion of Phase 2 construction activities. The remaining three surveys were conducted approximately 7, 12, and 24 months after completion of Phase 2 construction. Seafloor bathymetry data from the first and second surveys were primarily used to characterize the different types of seafloor disturbance features that resulted from Phase 1 and 2 construction activities. Data from the three rounds of post-construction surveys (Surveys 3, 4, and 5) were used to evaluate the rate of seafloor recovery.

A pair of innovative scour monitors were also field tested during the study. These were installed on the Turbine 3 foundation, and they recorded in real time changes in seafloor elevations up to a distance of

10 m (32.8 ft) from the foundation. A near-continuous seafloor elevation dataset was collected over the course of 14 months and 19 days. A seafloor-mounted acoustic wave and current profiler was installed nearby to provide data on oceanographic conditions (e.g., water levels, currents, and waves). Site-specific oceanographic data supported analyses and interpretation of data obtained from scour monitors.

The overall conclusion from monitoring surveys was that 1) a relatively small area of the seafloor off Block Island was disturbed by wind farm construction activities, and 2) much of the disturbed area fully recovered within a relatively short time. The criteria for designating sea bed as “fully recovered” was a condition in which no clear sign of any disturbance was evident as indicated by interpretation of the survey data. A “partially recovered” designation was assigned if only a section of a disturbance feature showed signs of recovery as indicated by interpretation of the survey data.

Key results and major conclusions from the monitoring surveys are summarized below:

- Wind farm construction activity was confined to a relatively small section of the seafloor off Block Island, which was designated as the Work Area. This area measured approximately 7,277,390 square meters (m^2) (1,798.3 acres [ac]). Within the Work Area,
 - Phase 1 construction activities directly affected approximately 11,570 m^2 (2.9 ac) of seafloor, which is less than 0.2 percent of the total Work Area. *The seafloor impact was therefore roughly equal to the area occupied by two football fields.* It is important to note that the 11,570 m^2 (2.9 ac) of affected area was distributed between 160 discrete and geographically scattered features—26 spud marks (1,102 m^2 [0.27 ac]), 69 circular depressions (2,803 m^2 [0.69 ac]), 44 drag marks (6,414 m^2 [1.58 ac]), and 21 scour features (1,251 m^2 [0.31 ac]).
 - The impact of Phase 2 construction on the seafloor was even less, affecting approximately 6,876 m^2 (1.7 ac) and consisting of 101 features—37 spud marks (4,152 m^2 [1.03 ac]), 51 circular depressions (1,595 m^2 [0.39 ac]), and 13 drag marks (1,129 m^2 [0.28 ac]). In other words, the seafloor area affected by Phase 2 construction activities was only slightly larger than one football field. Note that in addition to the 101 features, two new small scour features were recorded during Survey 2.
- Outside of the construction Work Area, seafloor impacts associated with the laying of the submarine transmission cable were also limited strictly to the cable route, which, compared to the larger seafloor off Block Island, covered a small area of the seafloor.
- ***Most of the seafloor disturbances directly associated with wind farm construction activities were temporary. Much of the damaged area was observed to completely recover over time as a result of sediment mobility, which results from bottom currents.*** These currents transport sediments that infill disturbance features and/or create, shift, or migrate bedforms such as ripples and dunes, and also contribute towards recovery of the disturbance features.
- Of the 160 disturbance features (covering 11,570 m^2 [2.9 ac] of seafloor) recorded during the first survey in May 2016, approximately 44.3 percent of the disturbed area (90 features covering approximately 5,122 m^2 [1.3 ac]) had completely recovered within 36 months (Survey 5 in September 2018), and the remaining 70 features showed partial recovery.
- Of the 101 additional disturbance features (covering an area of approximately 6,928 m^2 [1.7 ac]) documented during the second survey in October 2016, 70 percent of the disturbed area (86 features covering approximately 4,805 m^2 [1.2 ac]) had completely recovered within approximately 25 months, and the remaining 17 features covering approximately 2,023 m^2 (0.5 ac) showed partial recovery.
- Within approximately 4 months of being laid down in June 2016, almost 62 percent of the export cable scar had recovered and the remainder was partially recovered. Approximately 41 percent of the inter-array cable trench scar appeared to have completely recovered by September 2018

(Survey 5), and much of the rest was partially recovered. Twelve percent of the transmission cable scar had recovered within 4 months (Survey 2 in October 2016); the remainder was partially recovered.

- The rate of seafloor recovery was primarily dictated by water depth, existing sediment type, and prevailing current speeds, flow direction, and duration, which influenced sediment transport and bedform creation, shifting, and migration. Minor seasonal impacts on seafloor recovery rates were also documented.
- Since seafloor recovery attributable to sediment infilling is dictated by a complex interaction between factors such as water depth, sediment type, and prevailing current speeds, flow direction, and duration, it was anticipated that the seafloor disturbances around the five turbines would recover at different rates. The monitoring data analyses results confirmed this assumption. Note that the 5 turbines extend only across 2 miles, but even within this relatively small distance there is a difference in the type of seabed and currents.
- Based on bedform morphology, the seafloor within the Work Area was broadly divisible into a high recovery rate zone, a moderate recovery rate zone, and a low recovery rate zone. The rate of recovery in the high zone was almost 2.5 times higher than the rate of recovery in the moderate zone. No turbines or cables were installed in the low recovery rate zone.
- Scour associated with the concrete mats placed on the seafloor to protect the unburied section of the power transmission cables at the turbine entry points was observed only near Turbines 1 and 2. The scour features were approximately 5 to 25 centimeters (cm) (1.97 to 9.84 inches [in]) deep, and extended approximately 1 to 3 m (3.28 to 9.84 ft) from the mats. The scour marks were notably larger on the northwestern side of concrete mats, which potentially indicated the strong influence of a dominant bottom current flow direction.
- Over time, three of the four types of disturbance features documented—namely, spud marks, circular depressions, and drag marks—are expected to fully recover. Some extent of the scour features, on the other hand, are likely to remain as long as the hard structure (turbine foundations and concrete mats) remains in place.
- ***In general, most of the seafloor disturbances associated with construction activities occurred within an approximately 200 m (656.2 ft) area around each turbine. This observation may be used to guide delineation of construction-related direct impact areas for future wind farm facilities in the U.S. Seafloor disturbances associated with construction activities may be permitted only within the defined area.***
- Short-term trends from the real-time scour monitoring showed the seafloor level responding to changing oceanographic conditions. Seafloor levels were observed to fluctuate by up to 0.2 m (0.7 ft) with tidal conditions. Data also indicated that the seafloor scour level is generally deepest closest to the hard structure and gets shallower progressively with distance from the foundation. During periods of increased wave activity, the seafloor level showed reduced variation. Some correlation between the greatest levels of scour and the highest significant wave heights was also evident.
- Long-term trends from the real-time scour monitoring indicated a range of up to 0.6 m (2 ft) between the monthly maximum and minimum elevations.
- Scour associated with the turbine foundation legs also was evaluated using the multibeam survey data collected during the bathymetry surveys. This evaluation indicated scour depths of 10 to 25 cm (3.94 to 9.84 in) at the turbine legs, with the deepest scours observed at Turbines 1 and 2. It is important to note that bathymetry survey data only provide an instantaneous snapshot of scour conditions at a given location at a given point of time, whereas the scour monitors provide continuous data on monthly and seasonal scour development, infill processes, and seafloor

elevation changes during storm events—information that cannot be gleaned from conducting multibeam surveys at scattered intervals. Both methods are recommended to be used in parallel to better understand scour associated with the offshore turbine foundations.

- The results of the real-time scour monitoring may be used to guide design of field studies for monitoring scour conditions at future offshore wind farm facilities.

The data, findings, and recommendations presented in this report were generated for BOEM by the HDR RODEO Team under IDIQ Contract M15PC00002, Task Order M15PD00031.

1 Introduction

This report summarizes methods, data, observations, results, and major conclusions from seafloor disturbance and recovery monitoring conducted in and around the Block Island Wind Farm (BIWF). It also discusses methods and key observations from in-situ testing conducted at the wind farm with scour monitors that continuously recorded in real-time changes in seafloor elevations at a distance of up to 10 meters (m) (32.8 feet [ft]) from one selected turbine foundation. During the construction, sections of the power transmission cables were left unburied to allow them to be easily pulled into the turbines. Concrete mats were placed on the unburied cable sections for protection. Scour associated with the concrete mats was also evaluated during this monitoring.

Data from the bathymetry surveys were intended to provide information necessary for the U.S. Department of the Interior Bureau of Ocean Energy Management's (BOEM's) evaluation of environmental effects of future facilities, and to improve the accuracy of models and analysis criteria employed to establish monitoring controls and mitigations. The monitoring and testing were conducted under the BOEM's Real-Time Opportunity for Development Environmental Observations (RODEO) Program.

1.1 RODEO Program

The RODEO Program aims to make direct, real-time measurements of the nature, intensity, and duration of potential stressors during the construction and initial operations of selected proposed offshore wind facilities. This effort includes recording direct observations during the testing of different types of equipment that may be used during future offshore development to measure or monitor activities and their impact -producing factors.

Data collected under the RODEO Program may be used as input to analyses or models that are used to evaluate effects or impacts from future offshore activities. This Program is not intended to duplicate or substitute for any monitoring that may otherwise be required by developers of the proposed projects. Also, RODEO Program monitoring is coordinated with the industry and is not intended to interfere with, or result in, delay of industry activities.

The BIWF is the first facility to be monitored under the RODEO Program. All monitoring surveys were implemented in accordance with a preapproved field sampling plan, which included a project-specific safety, health, and environmental plan (**Appendix A**). **Table 1** identifies the types of field data collected under the RODEO Program during construction and/or initial operations of this facility.

1.2 Block Island Wind Farm

The BIWF is the nation's first offshore wind farm, and is located 4.5 kilometers (km) (2.8 miles [mi]) from Block Island, Rhode Island, in the Atlantic Ocean (**Figure 1**). Water column depth in the wind farm area is approximately 30 m (98.4 ft). The five-turbine, 30-megawatt facility is owned and operated by Deepwater Wind Block Island, LLC. Power from the turbines is transmitted to Block Island. A 32 km (19.9 mi) transmission submarine power cable transfers excess power from Block Island to the mainland. This cable is buried under the ocean floor and makes landfall on the mainland, north of Scarborough Beach at Narragansett, Rhode Island.

Table 1. RODEO Program monitoring conducted at the BIWF.

Phase	Key Activities	Dates	Monitoring Surveys	Comment
Construction Phase 1	<ul style="list-style-type: none"> Steel jacket foundations were installed on the seafloor using two different types of hammers. Both derrick barges and a lift boat were used as construction platforms. Piles were installed with a 13.27° rake from the vertical. 	26 July 2015–26 October 2015.	<ul style="list-style-type: none"> Visual observations and documentation of the construction activities. Airborne noise monitoring associated with the pile driving. Underwater sound monitoring associated with the pile driving. Seafloor sediment disturbance and recovery monitoring through bathymetry surveys conducted immediately after construction was completed and in approximately 3-month intervals for 1 year. Turbine platform scour monitoring through installation of two scour monitoring devices on selected turbine foundations. An Acoustic Wave and Current Profiler was also deployed within the Survey Area. 	Results, findings, and recommendations from Construction Phase 1 monitoring are presented in a report entitled “ <i>Field Observations during Wind Turbine Foundation Installation at the Block Island Wind Farm, Rhode Island</i> ” (HDR 2018).
Construction Phase 2	<ul style="list-style-type: none"> Turbines were installed on the steel foundations. 	13 May 2016–18 August 2016.	<ul style="list-style-type: none"> Airborne noise monitoring. Visual observations and documentation of activities. 	Results, findings, and recommendations from Construction Phase 2 monitoring are also presented in the report entitled “ <i>Field Observations during Wind Turbine Foundation Installation at the Block Island Wind Farm, Rhode Island</i> ” (HDR 2018).

Phase	Key Activities	Dates	Monitoring Surveys	Comment
	<ul style="list-style-type: none"> Submarine transmission power cables connecting Block Island and the mainland were laid using a jet plowing in the offshore portions and horizontal directional drilling in the near shore area. 	3 June 2016–26 June 2016.	<ul style="list-style-type: none"> Visual observations and documentation of the cable laying activities and of turbine installation from both onshore and offshore locations. Still photography and filming of portions of trenching operations for cable laying. Seafloor sediment disturbance monitoring. Post-construction seafloor recovery through bathymetry surveys. 	Results, findings, and recommendations from submarine transmission cable lay down monitoring were presented in a report entitled “ <i>Observing Cable Laying and Particle Settlement during the Construction of the Block Island Wind Farm</i> ” (Elliott et al. 2017).
Operational Phase	<ul style="list-style-type: none"> Testing of the newly installed turbines. Testing of the submarine transmission power cables. 	Operational testing conducted from 29 August 2016–30 November 2016.	<ul style="list-style-type: none"> Visual observations of the operational wind farm from varied distances at onshore and offshore locations. 	Results, findings, and recommendations from monitoring conducted during operational testing and initial operations are presented in a report entitled “ <i>Field Observations during Wind Turbine Operations at the Block Island Wind Farm, Rhode Island</i> ” (HDR 2019).
	<ul style="list-style-type: none"> Facility operations. 	Wind farm operation began 2 December 2016.	<ul style="list-style-type: none"> Airborne noise monitoring. Underwater sound monitoring. Seafloor sediment disturbance and recovery monitoring. Benthic monitoring. 	

BIWF construction began in July 2015, and was completed in a phased manner by the end of November 2016. During Phase 1, which lasted from 26 July to 26 October 2015, five turbine foundations were installed on the seafloor. These turbines were designated as wind turbine generator (WTG) 1 to WTG 5. Phase 2 construction was initiated in January 2016 and included laying of the submarine power transmission cables, and installation of the turbine towers, blades, and nacelles on the foundations. The facility started operations in December 2016. Detailed descriptions of the Phase 1 and 2 construction activities are presented in accompanying reports (Elliott et al. 2017; HDR 2018).

1.3 Report Organization

Bathymetry survey methods, data, observations, results, and major conclusions are summarized in individual sections of this report. Raw data and detailed discussions from each individual survey are presented in separate technical reports (Fugro 2016, 2017a, 2017b, 2017c, 2018, 2019), which are provided as digital appendices to this summary report:

- **Section 1** presents an overview of the BIWF Facility and the RODEO Program and includes a summary description of the activities conducted during the two construction phases.
- Seafloor disturbance and recovery assessment objectives, methods, and results are presented in **Section 2**.
- **Section 3** discusses the turbine scour assessment objectives, methods, and results.
- Major conclusions from the monitoring are listed and discussed in **Section 4**.
- References cited in the report are listed in **Section 5**.

2 Seafloor Disturbance and Recovery Assessment

Changes in seafloor topography over time as a result of wind farm construction activities were characterized by conducting high-resolution bathymetry surveys.

2.1 Survey Objectives

Previous studies from Europe have shown that introduction of solid structures onto the seafloor, such as the four-legged BIWF turbine jacket foundations, can modify near-bottom current flow processes and induce scour (Wilson 2007). This in turn may temporarily or permanently alter seafloor characteristics. Changes in seafloor characteristics may result in loss of native benthic habitat directly impacting benthic community abundance and diversity. It may possibly also compromise functionality and physical integrity of the structures themselves.

The seafloor can also be affected by several different construction-related activities such as vessel anchoring, life boat legs anchoring, and trenching for laying of submarine power transmission cables. Accordingly, the primary objectives of the seafloor disturbance and recovery monitoring surveys were to identify and characterize seafloor disturbances associated with wind farm construction activities and to monitor recovery times for the different types of disturbance features over time.

The study also included developing and field testing a methodology for monitoring seafloor scour around the turbine foundations in real time using innovative scour monitors. During wind farm construction, sections of the power transmission cables were left unburied to allow them to be easily pulled into the turbines. Concrete mats were placed on the unburied cable sections for protection. Scour associated with the concrete mats was also evaluated during this monitoring.

2.2 Survey Area

The survey area (**Figure 2**) consisted of approximately 7,277,390-square-meter (m^2) (1,798.3-acre [ac]) and it encompassed the extent of the seafloor designated by the project owners as the “Work Area.” During wind farm construction, vessels were primarily positioned within this area.

2.3 Survey Frequency

Five rounds of high-resolution bathymetry surveys were conducted, and during each round the entire seafloor within the delineated Work Area was surveyed (**Table 2**). The first survey was conducted in May 2016, approximately 7 months after completion of the Phase 1 construction. The second survey was conducted in October 2016, approximately 10 months after completion of Phase 1 construction activities and 2 months after completion of Phase 2 construction activities. The remaining three surveys were conducted approximately 7, 12, and 24 months after the completion of Phase 2 construction.

Seafloor bathymetry data from the first and second surveys were primarily used to characterize the different types of seafloor disturbance features that resulted from Phase 1 and 2 construction activities. Data from the three rounds of post-construction surveys (Surveys 3, 4, and 5) were used to evaluate the rate of seafloor recovery.

Technical details from the first three of the 5 surveys were collectively reported previously in a separate publication entitled “*Field Observations during Wind Turbine Foundation Installation at the Block Island Wind Farm, Rhode Island,*” OCS Study BOEM 2018-029. 175 pp. (HDR 2018).

Table 2. Seafloor disturbance and recovery monitoring bathymetry survey summary.

Survey No.	Construction Phase	Construction Activity Period	Major Activities Undertaken	Disturbance and Recovery Monitoring Survey Dates	Number of months after completion of Phase 1 construction activities	Number of months after completion of Phase 2 construction activities
1	Phase 1	26 July–26 October 2015	<ul style="list-style-type: none"> • Installation of steel jacket foundations on the seafloor 	11 and 12 May 2016	7	--
2	Phase 2	13 May–18 August 2016	<ul style="list-style-type: none"> • Wind turbine generators were installed on the foundations 	2 to 5 October 2016	10	2
		3 June–26 June 2016.	<ul style="list-style-type: none"> • Submarine transmission power cables connecting Block Island and mainland were laid using a jet plowing in the offshore portions and horizontal directional drilling in the near shore area 			
3	Post-Construction	--	--	18 and 19 May 2017	19	9
4	Post-Construction	--	--	2 and 3 October 2017	24	14
5	Post-Construction	--	--	29 and 30 September 2018	36	25

In addition to Work Area, the seafloor along the three submarine power transmission cable routes was surveyed as follows:

- Inter-array cable route: All segments were surveyed during each of the five surveys.
- Export cable route (which extends from the wind farm to Block Island):
 - Pre-lay survey (May 2016) covered approximately 87 percent of the route.
 - Post-lay survey (October 2016) covered approximately 95 percent of route.
- Transmission cable route (from Block Island to Rhode Island mainland):
 - Pre-lay survey (May 2016) covered 61 percent of the route.
 - Post-lay survey (July 2016) covered approximately 50 percent of route (mid-way point between Block Island and mainland).
 - Post-lay survey (October 2016) covered approximately 90 percent of the route.

2.4 Survey Methods

2.4.1 Surveying

The surveys were conducted from a small research vessel using a Reson SeaBat 7125 ultra-high-resolution multibeam echosounder. Patch tests and calibration checks were performed at the beginning of each survey. Sound velocity profiles were used to correct the bathymetric data for sound refraction or ray bending.

2.4.2 Data Processing

Bathymetric data were edited using CARIS software. After each survey line was examined and cleaned in CARIS' Swath Editor, the tide corrections were loaded and the lines were merged. The merged dataset was then examined to identify tidal discrepancies, sound velocity errors, motion errors, and data gaps.

All real-time positioning data were converted to World Geodetic System, 1984 (WGS84) (g1150) using an Applanix Position and Orientation System for Marine Vessels (POS MV). This real-time positioning was used to process the multibeam survey lines. Horizontal positioning error at the vessel's common reference point is estimated to be less than 1 m (3.3 ft) (during optimal conditions).

All data from the surveys were projected in metric measurement (m) with the Universal Transverse Mercator (UTM) Zone 19 North coordinate system, using WGS84 geodetic datum. The real-time navigation and position data were used as the geodetic control, receiving differential global navigation satellite system corrections via a G2 subscription to Fugro's OmniStar service. All real-time positioning data were converted to WGS84 (g1150) using an Applanix POS MV positioning system.

The data were reduced to mean lower low water based on the National Oceanic and Atmospheric Administration VDatum model.¹ This model provides separation values from the global navigation satellite system ellipsoid down to the chart datum of mean lower low water for the survey area. These values were then applied to the bathymetry using the CARIS HIPS Compute GPS Tide routine.

¹ <http://vdatum.noaa.gov>

Once all processing was completed, a digital terrain model (DTM) was generated with CARIS at a 0.5 m (1.6 ft) bin size. The American Standard Code for Information Interchange (ASCII) XYZ grid file of easting, northing, and depth values in meters was then output from CARIS for interpretation.

2.4.3 Data Interpretation

Processed bathymetric data were loaded into a workstation and interpreted using Environmental Systems Research Institute's ArcGIS version 10.4.1 software program. In addition to the DTM, ArcGIS was used to create bathymetric contours and sun-illuminated, hill shaded-relief renderings of the seafloor DTM to enhance seafloor features and aid in visually identifying seafloor disturbances. Initially, a sink analysis was performed on each survey dataset using ArcGIS. The sink analysis identifies all closed depressions (e.g., spud depression).

After the automated screening step was completed, a user reviewed the features and accepted or rejected the feature as being related to construction activities. Also during the review of each feature, the user refined the digitized extent of the feature and calculated the size of each feature (e.g., area, perimeter, and depth). Each digitized feature was associated with the respective construction phase and stored in a geographic information system database file.

Interpreted seafloor disturbance features (**Figure 3**) were classified based on the following:

- **Spud:** Circular or rectangular depressions arranged in a pattern that match one of the lift boats and are generally located near a turbine. Likely created when a lift boat was on position during installation of the foundation.
- **Circular Depression:** Circular depression not associated with a geometric pattern that would have been created when a lift boat was on position and had all three or four legs deployed. Circular depression was generally located away from the turbine foundations and may be related to a spud depression or anchor drop.
- **Drag Mark:** Elongated or linear disturbance feature likely created from the dragging of a spud leg or anchor.
- **Scour:** Scour feature that formed around the leg of the jacket foundation or around the concrete mat cable protection.

Survey data were evaluated to determine location and extent (size) of the various types of seafloor disturbances and rate of recovery of each disturbance type. The extent of the seafloor disturbance features interpreted from each round of surveys were compared with the extent of the same features in the previous survey to track recovery, which was characterized as either completely recovered, partially recovered, or showed no change. A “*completely or fully recovered*” characterization was assigned if the feature was no longer discernable in the survey data output. A “*partially recovered*” designation was assigned if only a section of a disturbance feature showed signs of recovery as indicated by interpretation of the survey data. Impact of seafloor mobility on the recovery rates was determined for the disturbed areas.

2.4.4 Data Variability and Repeatability

Water depths from an area outside the likely construction impact zone (reference site) were used to establish a baseline degree of variability between the three surveys. Elevation differences between the surveys were obtained by extracting data within the likely impact zone and then subtracting values on a bin node-by-node basis. An average systematic bias of -0.04 m (-0.1 ft) and 0.02 m (0.07 ft) was observed in the sample set that can likely be attributed to tidal error, subtle boat draft discrepancies, and normal limitations associated with multibeam head calibration.

2.4.5 Data Quality

Sea states during the May 2016 survey were calm, resulting in good-quality raw data. Minimal data processing was required to generate bathymetric deliverables that were free of motion artifacts and other surface noise. Sea states during the October 2016 were fair to marginal. Quality of the raw data collected during the October 2016 survey was reported to be affected by the marginal sea states, and motion artifacts were noted on the outer portions of the bathymetric swath.

Post-acquisition data processing resulted in final deliverables of good quality; however, some motion-related artifacts are still observable in the final DTM, but the data are deemed adequate for meeting the study's objectives. Data quality for the raw data collected for the May 2017 survey was affected by some motion in the moonpool at the time of the survey; however, the overall data quality was good and post-acquisition data processing resulted in final deliverables of good quality.

2.5 Survey Results and Discussion

Key data, results, and conclusions from the five bathymetry surveys are summarized below. Detailed technical reports from each survey are contained in **Appendices C to G**.

2.5.1 Survey 1

Survey 1 was conducted on 11 and 12 May 2016, approximately 7 months after the completion of Phase 1 seafloor-affecting construction activities (**Table 2**). During this survey, 160 seafloor disturbance features were interpreted. These 160 features collectively covered approximately 11,570 m² (2.86 ac) and included 26 spud marks, 69 circular depressions, 44 drag marks, and 21 scour features (**Table 3**). Circular depressions made up the largest number of features; drag marks made up the largest total area of impact (6,414 m² [1.58 ac]). Additional data, observations, and results from Survey 1 are contained in the technical report presented in **Appendix C**.

2.5.2 Survey 2

Survey 2 was conducted from 2 to 5 October 2016, approximately 10 months after completion of Phase 1 construction activities and 2 months after completion of Phase 2 construction activities (**Table 2**). During this survey, 103 new seafloor disturbance features were documented. These features collectively encompassed an area of approximately 6,876 m² (1.7 ac) and included 37 spud marks, 51 circular depressions, 13 drag marks, and two scour features (**Table 3**). Circular depressions made up the largest number of features; spud impressions made up the largest total area (4,152 m² [1.03 ac]). New seafloor disturbance features that appeared to be associated with the construction Phase 2 were concentrated around each of the five turbine locations and along the inter-array cable route.

Survey 2 data were also used to compare the area affected by laying of export cable (wind farm to Block Island) and the Block Island transmission cable (Block Island to mainland) before and after the cable laying was completed. The data indicated that approximately 12 percent of the transmission cable trench scar had completely recovered, and that 62 percent of the export cable trench scar had completely recovered within 4 months of lay down. Additional data, observations, and results from Survey 2 are contained in the technical report presented in **Appendix D**.

2.5.3 Survey 3

Survey 3 was conducted on 18 and 19 May 2017, approximately 19 months after completion of Phase 1 construction activities and 9 months after completion of Phase 2 construction activities (**Table 2**).

Table 3. Comparison of Survey 1 and Survey 2 Results

Feature Type	Survey 1 (May 2016) (6 months after completion of Phase 1 construction activities in October 2015)		Survey 2 (October 2016) (2 months after completion of Phase 2 construction activities)		Total seafloor disturbance after completion of Phase 1 and 2 construction activities	
	Number of features associated with Phase 1 construction	Total area of features (m ²)	Number of new features associated with Phase 2 construction	Total area of features (m ²)	Total number of features	Total area of features (m ²)
Spuds	26	1,102	37	4,152	63	5,254
Circular Depressions	69	2,803	51	1,595	120	4,398
Drag Marks	44	6,414	13	1,129	57	7,543
Total	139	10,319	101^b	6,876	240	17,195

Notes:

- Features were classified as partially recovered if the disturbance feature had lessened in size or depth but still remained discernible. A feature was classified as completely recovered if the feature was no longer discernible in the bathymetric data.
- Twenty-one scour features were identified from the Construction Phase 1 disturbances, which results in a total of 160 disturbance features from Season 1. Two new scour features were identified from Construction Phase 2 disturbances, which results in a total of 103 disturbance features from Season 2. Scour features formed as a result of installing wind turbine foundations or concrete mats. The scour features are not included in the recovery statistics since they are likely to be present as long as the structures (e.g., foundations and concrete mats) are present.
- Inter-array and export cable trench scars and recovery are not included in this table.

Table 4. Recovery Tracking of Construction Phase 1 Seafloor Disturbance Features

Feature Type	Number of features observed during Survey 1 (May 2016)	Survey 2 (October 2016) observations			Survey 3 (May 2017) observations			Survey 4 (October 2017) observations			Survey 5 (September 2018) observations		
		Number of partially recovered features	Number of completely recovered features	Recovered area (m ²)	Number of partially recovered features	Number of completely recovered features	Recovered area (m ²)	Number of partially recovered features	Number of completely recovered features	Recovered area (m ²)	Number of partially recovered features	Number of completely recovered features	Recovered area (m ²)
Spuds	26	19	0	0 (0%)	8	18	663 (60%)	3	20	710 (64%)	4	20	710 (64%)
Circular Depressions	69	0	3	58 (2%)	31	38	1,454 (52%)	12	44	1,634 (58%)	21	48	1,752 (63%)
Drag Marks	44	1	12	1,300 (20%)	25	19	2,077 (32%)	10	20	2,540 (40%)	22	22	2,660 (41%)
Total	139	20	15	1,358 (13%)	64	75	4,194 (41%)	25	84	4,884 (47%)	47	90	5,122 (50%)

Notes:

- Features were classified as partially recovered if the disturbance feature had lessened in size or depth but still remained discernible. A feature was classified as completely recovered if the feature was no longer discernible in the bathymetric data.
- Twenty-one scour features were identified from the Construction Phase 1 disturbances, which results in a total of 160 disturbance features from Season 1. Two new scour features were identified from Construction Phase 2 disturbances, which results in a total of 103 disturbance features from Season 2. Scour features formed as a result of installing wind turbine foundations or concrete mats. The scour features are not included in the recovery statistics since they are likely to be present as long as the structures (e.g., foundations and concrete mats) are present.
- Inter-array and export cable trench scars and recovery are not included in this table.

Table 5. Recovery Tracking of Construction Phase 2 Seafloor Disturbance Features

Feature Type	Number of features observed in October 2016 ^a	Survey 3 (May 2017) observations			Survey 4 (October 2017) observations			Survey 5 (September 2018) observations		
		Number of partially recovered features	Number of completely recovered features	Recovered area (m ²)	Number of partially recovered features	Number of completely recovered features	Recovered area (m ²)	Number of partially recovered features	Number of completely recovered features	Recovered area (m ²)
Spuds	37	25	12	830 (20%)	12	17	1,790 (43%)	11	26	2,269 (55%)
Circular Depressions	51	8	43	1,298 (81%)	7	46	1,388 (87%)	5	47	1,407 (88%)
Drag Marks	13	1	12	1,061 (94%)	0	13	1,129 (100%)	0	13	1,129 (100%)
Total	101	34	67	3,189 (46%)	19	76	4,307 (63%)	16	86	4,805 (70%)

Notes:

- Features were classified as partially recovered if the disturbance feature had lessened in size or depth but still remained discernible. A feature was classified as completely recovered if the feature was no longer discernible in the bathymetric data.
- Twenty-one scour features were identified from the Construction Phase 1 disturbances, which results in a total of 160 disturbance features from Season 1. Two new scour features were identified from Construction Phase 2 disturbances, which results in a total of 103 disturbance features from Season 2. Scour features formed as a result of installing wind turbine foundations or concrete mats. The scour features are not included in the recovery statistics since they are likely to be present as long as the structures (e.g., foundations and concrete mats) are present.
- Inter-array and export cable trench scars and recovery are not included in this table.

Data from this survey indicated that of the 160 disturbance features noted during Survey 1, 75 were completely recovered and 64 had partially recovered (**Tables 4 and 5**). The completely recovered features covered approximately 4,194 m² (1.04 ac), which indicated that approximately 36 percent of the disturbed area was completely recovered. Sixty of the 75 features that were completely recovered were located in or adjacent to areas with predominantly fine-grained sand. The other 15 features were in areas with predominantly medium- to coarse-grained sand. This observation indicated that disturbance features in areas with predominantly fine-grained sand recovered faster than areas that were predominantly characterized by medium- to coarse-grained sand.

Of the 103 disturbance features documented in Survey 2, Survey 3 data indicated that 68 features had completely recovered, 34 were partially recovered, and one showed some signs of recovery. The completely recovered features encompassed an area of 3,189 m² (0.79 ac), which indicated that approximately 46 percent of the disturbed area has completely recovered. Fifty-six of the 68 features that have completely recovered were in or adjacent to areas with predominantly fine-grained sand. The other 12 features were in areas with predominantly medium- to coarse-grained sand. This observation confirmed that disturbance features in areas of predominantly fine-grained sand were recovering faster than those in areas with predominantly medium- to coarse-grained sand.

Survey 3 data also showed the presence of 12 new scour features covering approximately 844 m² (0.21 ac) that had developed around the concrete mats placed on the seafloor to protect the cable at the turbine entry points. These scour features were associated with the concrete mats placed around TURBINE 1 and 2 only, and they appeared to be notably deeper and wider on the northwestern side of the mats, which potentially indicated the strong influence of a dominant bottom current flow direction.

Comparison of data from the first three surveys also showed changes in seafloor bedforms, which indicated that the seafloor was active during the time between the surveys. Orientations of ripples in a large ripple field located between Turbines 3 and 5 was observed to change between Surveys 1 and 2. During Survey 1, the ripple crestlines were primarily oriented east-west but during Survey 2 the orientation had changed to northeast-southwest. Size of the ripples also declined from approximately 10 cm (3.94 in) in Survey 1 to 5 cm (1.8 in) in Survey 2. From Survey 2 to Survey 3, the orientation of the ripple fields had shifted back to their original east-west orientation and the ripples also increased in height back to almost approximate 10 cm (3.94 in). The change in orientation and height of the ripple field may reflect seasonal differences. Both Survey 1 and 3 were conducted at the end of winter and Survey 2 was completed at the end of summer. Seasonal changes may have facilitated a more rapid recovery of the disturbance features in this area.

Additional data, observations, and results from Survey 3 are contained in the technical report presented in **Appendix E**.

2.5.4 Survey 4

Survey 4 was conducted on 2 and 3 October 2017, approximately 24 months after completion of Phase 1 construction activities and 14 months after completion of Phase 2 construction activities (**Table 2**). Of the 160 disturbance features documented during Survey 1, Survey 4 results indicated that approximately 42 percent of the disturbed area (84 features covering approximately 4,884 m² [1.21 ac]) had completely recovered and 55 features (6,686 m² [1.65 ac]) showed partial recovery. Seventy of the 84 completely recovered features were located in or adjacent to areas with predominantly fine-grained sand (**Tables 4 and 5**). The other 14 features were located in or adjacent to areas characterized predominantly by medium- to coarse-grained sand.

Of the 103 disturbance features resulting from Phase 2 construction activities in 2016 (covering an area of approximately 6,928 m² [1.71 ac]), Survey 4 revealed that 62 percent of the disturbed area (76 features covering approximately 4,307 m² [1.08 ac]) had completely recovered, 25 showed partial recovery, and two showed no change. Sixty-seven of the 76 completely recovered features were located in or adjacent to areas characterized predominantly by fine-grained sands. The other 13 features were located in or adjacent to areas with predominantly medium- to coarse-grained sands.

Survey 4 data also indicated the following:

- The 12 scour features observed around Turbines 1 and 2 concrete mats during Survey 3 remained mostly unchanged. Three of the scour features adjacent to TURBINE 1 did appear to undergo some infilling, and one (located on the northwestern side of the mat) also showed slight deepening.
- Thirty-nine percent of the inter-array cable trench scar appeared to be completely recovered. The variance in recovery rates of the different cable trench scars is likely attributable to a combination of factors such as water depth, grain size, and bottom current speeds.

As previously noted under Survey 3, the seafloor in the Work Area continued to show signs of being very active. Between Surveys 1, 2, 3, and 4, ripple fields were observed to grow in spatial extent and size. Thirty-four percent of the Work Area was characterized by ripple fields during Survey 4, and the fields were approximately two times taller than observed during the previous surveys. Additional data, observations, and results from Survey 1 are contained in the technical report presented in **Appendix F**.

2.5.5 Survey 5

Survey 5 was conducted on 20 and 30 September 2018, approximately 36 months after completion of Phase 1 construction activities and 25 months after completion of Phase 2 construction activities (**Table 2**). Of the 160 disturbance features encompassing approximately 11,570 m² (2.86 ac) recorded during Survey 1, Survey 5 results indicated that approximately 44.3 percent of the disturbed area (90 features covering approximately 5,122 m² [1.27 ac]) had completely recovered, and the remaining 70 features showed partial recovery (**Tables 4 and 5**).

Of the 103 disturbance features documented during Survey 2 (covering an area of approximately 6,928 m² [1.71 ac]), Survey 5 revealed that 70 percent of the disturbed area (86 features covering approximately 4,805 m² [1.19 ac]) had completely recovered, and 17 features showed partial recovery. Additional data, observations, and results from Survey 5 are contained in the technical report presented in **Appendix G**.

2.6 Characterization of Seafloor Disturbances and Recovery around Individual Turbines

Seafloor disturbances resulting from Phase 1 and 2 construction activities within an approximately 175 m (574.2 ft) active work zone around each turbine foundation were characterized and evaluated. The 175 m (574.2 ft) work zone around each turbine encompassed the seafloor where the construction vessels were positioned (anchored) during construction, and it included the seafloor under the foundation. Disturbance features observed within this active work zone were characterized as follows:

- **Temporary features:** disturbance caused by construction equipment activities that temporarily occurred on site (e.g., jacking-up of a vessel that left the site after a few hours or days).
- **Long-term features:** disturbance (scour) related to a structure being installed at the site until the project is decommissioned. Scour features related to turbine foundations or concrete mats are examples of long-term features anticipated to be present until the structure is removed.

- **Cable trench features:** Inter-array cable trench scar and concrete mats created during Construction Phase 2.

Table 6 presents a list of disturbance features catalogued within the 175 m (574.2 ft) work zone round each of the five turbines. A side-by-side comparison of the disturbance features and recovery patterns within the 175-m (574.2-ft) work zone is shown in **Figure 4**.

2.6.1 Turbine 1

Turbine 1 is located in the northeastern section of the survey area. The surficial sediments around this turbine are characterized by coarse- to medium-grained sand with fine gravel, and include patches of rippled sand and gravel. Major observations from evaluation of survey data around this turbine are presented below; additional details are contained in the technical report shown in **Appendix C**.

Survey 1: Twenty-one well-defined seafloor disturbances were documented around Turbine 1 as a result of Phase 1 construction activities. Over a 12-month period (i.e., through May 2017), 12 of the 21 disturbances appeared to have completely recovered and were not discernable, 5 appeared diminished in depth most likely because of sediment infilling of up to 8 cm (3.2 in), and the remaining four disturbances did not show any significant change.

Survey 2: A total of 48 well-defined disturbance features were documented around Turbine 1 as a result of Phase 2 construction activities. Over a 7-month period (through May 2017), 33 of the 48 were completely recovered and the remaining 15 showed varying levels of recovery because of sediment infilling.

Survey 3: Several new scour features appeared to have formed on the seafloor around this turbine since the completion of the Phase 2 construction activities. These features include disturbances on either side of the concrete mats that were placed on top of the inter-array cable to provide protection to the section of cable that was intentionally not buried. The depth of scour for these features ranges from 5 to 20 cm (2 to 7.9 in) and extends up to approximately 3 m (9.8 ft) from the concrete mats. Scour development appears to be more extensive in both depth and size on the northwest side of the cable, possibly indicating a dominant flow direction of bottom currents.

Survey 4: Twelve of the 21 seafloor disturbance features documented during Survey 1 appear to have completely recovered and were no longer discernable. Seven of 21 appeared to have diminished in depth associated with sediment infilling (up to 4 cm [1.57 in]). The remaining two of 21 displayed no significant change.

Thirty-six of the 48 seafloor disturbance features documented during Survey 2 appear to have completely recovered and were no longer discernable. Nine of the 48 features experienced some change associated with sediment infilling. The most prominent of these features that remained visible in Survey 4 were four spud depressions associated with the L/B Brave Tern. Although the area covered by these nine features (approximately 150 m² [0.04 ac]) remains almost unchanged, they all appear to have undergone some level of infilling ranging from 0.1 to 0.2 m (0.33 to 0.66 ft). Five of the nine features appear to have experienced very small amounts of sediment infilling ranging from approximately 1 to 3 cm (0.39 to 1.18 in). No significant change was observed during Survey 4 in the remaining three of 48 features that were originally cataloged during Survey 2.

Two of the six scour features documented during Survey 3 associated with the concrete mats appear to have undergone some level of sediment infilling. No significant change was observed in the remaining four concrete mat scour features.

Table 6. Seafloor Disturbances within 175 m (574 ft) Work Zone of Each Turbine

Turbine ID	Construction Phase 1 Temporary Features ^a	Construction Phase 2 Temporary Features ^a	Construction Phase 1 and Construction Phase 2 Temporary Features ^a	Long-term Features (Foundations) ^a	Long-term Features (Concrete Mats on Cables) ^a	Cable Trench Features ^a	All Features Combined Phase 1 and 2 ^a
WTG 1	838 m ² 0.9%	2,261 m ² 2.4%	3,099 m ² 3.2%	308 m ² 0.3%	1,074 m ² 1.1%	1,266 m ² 1.3%	5,747 m ² 6.0%
WTG 2	180 m ² 0.2%	1,001 m ² 1.0%	1,181 m ² 1.2%	268 m ² 0.3%	840 m ² 0.9%	1,566 m ² 1.6%	3,855 m ² 4.0%
WTG 3	100 m ² 0.1%	1,003 m ² 1.0%	1,103 m ² 1.1%	264 m ² 0.3%	840 m ² 0.9%	1,692 m ² 1.8%	3,899 m ² 4.1%
WTG 4	1,100 m ² 1.1%	1,201 m ² 1.2%	2,301 m ² 2.4%	290 m ² 0.3%	636 m ² 0.7%	1,716 m ² 1.8%	4,943 m ² 5.1%
WTG 5	508 m ² 0.5% ^b	508 m ² 0.5%	1,016 m ² 1.1% ^b	109 m ² 0.1%	426 m ² 0.4%	1,038 m ² 1.1% ^c	2,589 m ² 2.7% ^b

Notes:

^a Disturbance is presented in area and percentage of area within 175 m (574.2 ft) of the wind turbine. This is assumed to be the area where installation vessels would be positioned during construction of a wind turbine.

Season 1 seafloor disturbance features were not discernable for Turbine 5. Seafloor disturbance (e.g., leg penetration) likely was limited because of dense sandy sediments at that location and reworking of sediments likely recovered seafloor scars by the time the survey was conducted. We have assumed the seafloor disturbance during Season 1 to be equal to Season 2 for estimating purposes. This likely is a conservative assumption.

Turbine 5 has only one cable connection whereas the other turbine locations have two.

Footprint of foundation piles are included in disturbance area.

Survey 5: Thirteen of the 21 features reported after Survey 1 appear to have completely recovered and were not discernable. Seven of the 21 features seem to have diminished in depth associated with sediment infilling of up to 4 cm (1.57 in). The remaining feature showed no significant change.

Forty of the 48 features reported in Survey 2 appear to have completely recovered and were no longer discernable. Five of the 48 features, which includes the four L/B Brave Tern spud depressions covering approximately 150 m² (0.04 ac), appear to have experienced some level of sediment infilling (0.1 to 0.2 m [0.33 to 0.66 ft]), but are still discernable. The remaining three of 48 features do not appear to have undergone any significant change.

The extent of scour around the concrete mats placed on the inter-array cable reported in Survey 3 remained unchanged. These scour features extended approximately 1 to 3 m (3.28 to 9.84 ft) from the mats and are approximately 10 to 25 cm (3.94 to 9.84 in) deep. Scour is most prevalent on the northern side of the cable/concrete mats, which indicates the dominant tidal current flow at this location is likely to the north-northwest (flood tidal current direction).

Scour around the turbine legs appeared to be small to negligible based on the multibeam data. Small depressions up to approximately 5 to 20 cm (1.97 to 7.87 in) deep were interpreted in previous monitoring surveys. In Survey 5, this scour appeared to be less than approximately 10 cm (3.94 in) at the legs.

2.6.2 Turbine 2

Turbine 2 is also located in the northeastern-most section of the study area, and surficial sediments in this area are similar to those observed around Turbine 1. Major observations from evaluation of survey data around this turbine are presented below; additional details are contained in the technical report shown in **Appendix D**.

Survey 1: The May 2016 bathymetry surveys showed 10 well-defined seafloor disturbances around Turbine 2 as a result of the Phase 1 construction activities. Over a 12-month period (through May 2017), four of the 10 features appeared to have completely recovered and were no longer discernable, two were reduced in depth because of sediment infilling of up to 3 cm (1.2 in), one appeared to have widened in extent to the northwest by approximately 1.5 m (4.9 ft), and the remaining three did not show any change.

Survey 2: The October 2016 bathymetry survey indicated 16 well-defined disturbance features around Turbine 2 as a result of the Phase 2 construction activities. Over a 7-month period (through May 2017), seven of the 16 features were completely recovered and are no longer discernable, and the remaining nine experienced some degree of change associated with sediment infilling.

Survey 3: The May 2017 survey showed several new scour features that were formed since the completion of the Phase 2 construction activities. These scour features were observed on either side of the concrete mats that were placed on top of the inter-array cable to provide protection of the section of cable that was intentionally not buried. The depth of scour marks ranged from 5 to 20 cm (2 to 7.9 in) and extended up to approximately 3 m (9.8 ft) from the concrete mats. Scour development appeared to be more extensive in both depth and size on the northwest side of cable, possibly indicating a dominant flow direction of bottom currents.

Survey 4: Five of the 10 seafloor disturbances adjacent to Turbine 2 that were originally identified in Survey 1 appeared to have completely recovered and were no longer discernable. One disturbance feature seems to have undergone a small amount of sediment infilling (about 5 cm [1.97 in]). No significant change was observed in the remaining four of 10 features.

Eight of the 16 seafloor disturbance features documented during Survey 2 appeared to have completely recovered because they were no longer discernable. Four of the 16 features seemed to have experienced some degree of sediment infilling (ranging from 0.05 to 0.10 m [0.16 to 0.33 ft]); the most notable of these were the spud depressions associated with the L/B Brave Tern. Of the four spud depressions, the two to the southeast infilled by up to 50 percent more than the two located on the northwestern side of the turbine. No significant change was observed in the remaining four of 16 disturbance features. Also, no significant change was observed in the five scour features that were documented during Survey 3 along the concrete mats.

Survey 5: Five of the 10 features reported in Survey 1 appeared to have completely recovered and were no longer discernable. The remaining five features showed little to no change. Twelve of the 16 features reported in Survey 2 appeared to have completely recovered and were no longer discernable. The remaining four (L/B Brave Tern spud depressions) seem to have experienced some additional sediment infilling, approximately 5 to 10 cm (1.97 to 3.94 in) since Survey 4. Overall, when the spud depression were first reported after Survey 2, their depth ranged from 40 to 80 cm (15.75 to 31.5 in). In Survey 5, approximately 50 to 80 percent of these features appeared to have been infilled with sediments.

The scour features reported in Survey 3 adjacent to the concrete mats placed on the inter-array cable near Turbine 2 appeared largely unchanged between Surveys 4 and 5. These features extended approximately 1 to 2 m (3.28 to 6.56 ft) from the mats and were approximately 5 to 20 cm (1.97 to 7.87 in) deep. Scour was more prominent on the northern side of the concrete mats, which is oriented perpendicular to the principle tidal current flow direction. Scour was most prevalent on the northern side of the cable/concrete mats, which indicated that the dominant tidal current flow at this location was likely to the north-northwest (flood tidal current direction).

Based on the multibeam data, scour around the turbine legs appeared to be very small. Small depressions up to approximately 5 to 20 cm (1.97 to 7.87 in) deep were interpreted in previous surveys. In Survey 5, scour appeared to be less than approximately 10 to 15 cm (3.94 to 5.91 in) at the legs.

2.6.3 Turbine 3

Turbine 3 is located in the central section of the study area, in a slightly deeper channelized area of the seafloor where wave ripples were more dominant. The surficial sediment surrounding this turbine is predominantly medium-grained sand with a minor component of fine gravel. Major observations from the evaluation of survey data around this turbine are presented below; additional details are contained in the technical report shown in **Appendix E**.

Survey 1: Eight well-defined seafloor disturbances were shown around this turbine. Over a 12-month period (through May 2017), four of these eight features remained unchanged.

Survey 2: Four spud depressions were revealed around Turbine 3 as a result of the Phase 2 construction activities. Over a 7-month period (through May 2017), one of four spud depression had completely recovered and the remaining three showed a decrease in depth attributable to an average sediment infilling of approximately 1 m (3.3 ft).

Survey 3: No new seafloor disturbance features were observed on the seafloor around Turbine 3 in May 2017.

Survey 4: Four of the eight seafloor disturbance features originally cataloged during Survey 1 were not discernable, while the other four remained visible with no significant change. The four L/B Brave Tern spud depressions recorded during Survey 2 appeared to have completely recovered.

Survey 5: Four of the eight features reported under Survey 1 had completely recovered and were not discernable. The remaining three of the eight features displayed no significant change and were still visible. The four L/B Brave Tern spud depressions identified in Survey 2 appeared to be completely recovered and were not discernable. Overall, when they were first reported in Survey 2, the four spud depression ranged in depth from 70 and 110 cm (27.56 to 43.31 in) and they had undergone significant infilling (80 to 85 percent) between Surveys 2 and 3, and were no longer discernable by Survey 5.

No significant erosional features were previously reported adjacent to the concrete mats placed on the inter-array cable near this turbine. Scour around the turbine legs appeared to be very small based on the multibeam data. Small depressions up to approximately 5 to 25 cm (1.97 to 7.87 in) deep were interpreted in previous surveys. In Survey 5, these scour marks appeared to be less than approximately 10 to 15 cm (3.94 to 5.91 in) at the legs.

The real-time scour monitors, which were installed on the northeast and southeast corner legs of this turbine, continuously recorded seafloor elevation changes over a 14-month period. These data showed seafloor level changes of up to approximately 0.2 m (0.66 ft) over tidal cycles and 0.6 m (1.97 ft) over 1-month periods. See Section 3 for additional discussion of the scour monitoring results.

2.6.4 Turbine 4

Turbine 4 is located in the southwestern section of the study area, and the surficial sediments surrounding this turbine are made up of coarse sand and contain alternating patches (ridges/furrows) of sand and gravel. Wave ripples up to 10 cm (3.9 in) were also observed on the seafloor. Major observations from evaluation of survey data around this turbine are presented below; additional details are contained in the technical report shown in **Appendix F**.

Survey 1: Showed nine well-defined seafloor disturbances around this turbine as a result of the Phase 1 construction activities. Over a 12-month period (through May 2017), four of the nine features were completely recovered and the remaining five showed no measurable change.

Survey 2: Revealed 10 disturbance features around Turbine 4 as a result of the Phase 2 construction activities. Over a 7-month period (through May 2017), 6 of the 10 were completely recovered, and the remaining four, which were spud depressions, underwent varying levels of sediment infilling. Of the four spud depressions that were still discernable during Survey 2, the two located toward the southwest seemed to have filled in with twice as much sediment as compared to the two located to the northwest. This differential infilling rate is probably attributable to the southwesterly depressions being located in an actively migrating sand ripple field.

Survey 3: No new seafloor disturbance features were observed on the seafloor around Turbine 4.

Survey 4: Four of the original nine disturbance features documented during Survey 1 appear to have completely recovered and were not discernable. The remaining five of nine experienced little to no change. Also, six of the 10 disturbance features identified during Survey 2 appeared to have completely recovered and were not discernable. The remaining four of 10 features were L/B Brave Tern spud depressions. Two of the four spud depressions located toward the southwest experienced a small amount of sediment infilling (approximately 8 cm [3.15 in]), while the two spud depressions located to the northeast did not show any significant recovery. This difference in sediment infilling could be because the spud depressions to the southwest are located in an actively migrating sand ripple field, and this migration of bedforms and sediments produced a more rapid infill rate.

Survey 5: Five of the nine features reported in Survey 1 appeared to have completely recovered and were not discernable. Two of the nine showed some level of sediment infilling, whereas the other two showed

no change at all. Eight of the 10 features reported during Survey 2 appeared to have completely recovered and were not discernable. The remaining two of eight features are the two L/B Brave Tern northeastern spud depressions and they appear to have experienced very little infilling since Survey 4. The differing infill rates between the northeastern and southwestern L/B Brave Tern leg spud depressions was remarkable. The two southwestern leg depressions that had completely recovered by Survey 5 were located in a ripple field that had actively changed between surveys. The ripples changed in orientation and extent, indicating higher rates of sediment reworking than where the two northeastern depressions are located. Survey 5 data showed that the two northeastern spud depressions, which measured up to approximately 60 cm (23.62 in) deep during Survey 2, were about 40 to 50 percent infilled at the time of Survey 5.

No apparent erosional features were observed around the concrete mats. Scour at the legs around this turbine was notably less than at Turbines 1 and 2. Scour interpreted from the monitoring surveys were observed to be up to approximately 4 to 10 cm (1.57 to 3.94 in) around the legs of this turbine.

2.6.5 Turbine 5

Turbine 5 is also located in the southwestern section of the study area, and the surficial sediment surrounding this turbine is predominantly medium sand. Major observations from evaluation of survey data around this turbine are presented below; additional details are contained in the technical report shown in **Appendix G**.

Survey 1: Showed four well-defined seafloor disturbances around Turbine 5 as a result of the Phase 1 construction activities. Over a 12-month period (through May 2017), none of these features showed significant change.

Survey 2: Showed four additional disturbance features around Turbine 5 as a result of the Phase 2 construction activities. Over a 7-month period (through May 2017), all four of these features had completely recovered.

Survey 3: No new seafloor disturbance features were observed.

Survey 4: None of the four disturbances features reported from Survey 1 displayed any significant change. All four features reported from Survey 2 had completely recovered and were not discernable.

Survey 5: All disturbances features reported in Survey 1 showed some slight change related to sediment infilling. All four features identified in Survey 2 appear to have completely recovered and were not discernable. No erosional features were observed around the concrete mats. Scour at the legs of this turbine is notably less than at Turbines 1 and 2. Scour interpreted from the monitoring surveys was observed to be up to approximately 4 to 9 cm (1.57 to 3.54 in) around the turbine legs.

2.7 Characterization of Seafloor Disturbances Elsewhere in the Survey Area

2.7.1 Seafloor between the Turbines

The five turbines are approximately 0.8 km (0.5 mi) apart from each other. Bathymetry survey data of the seafloor between the turbines were interpreted to estimate and track recovery of seafloor disturbances that resulted from wind farm construction activities in these areas. Survey 1 was conducted after completion of Phase 1 construction activities, and the most notable disturbance features noted during Survey 1 were linear drag marks ranging from approximately 150 to 200 m (492.1 to 656.2 ft) that were observed

between Turbine 1 and 2, southeast of Turbine 2, and around Turbine 4. These 10 to 20 cm (3.94 to 7.87 in) deep drag marks were oriented northeast to southwest and were generally aligned with the proposed inter array cable route. These drag marks were most likely caused by Phase 1 construction vessel activity.

A few other disturbance features were also noted in this area. However, none of these features matched the three-leg triangle pattern from the three lift boats working in the area, and none of the depressions were wide enough to match the mud-mat diameter of the lift boats. Therefore, these marks could be positively attributed to any of the lift boats that were active in the area during Phase 1 construction.

Survey 2, which was conducted after completion of Phase 2 construction activities, showed presence of more than 100 additional anthropogenic seafloor disturbance features, such as circular depressions and drag scars, in the areas between the five turbines. The depressions ranged in diameter from approximately 3 to 14 m (9.84 to 45.93 ft) and were approximately 9 cm (3.54 in) deep. The drag marks scars were approximately 11 to 88 m (36.09 to 262.47 ft) in length.

Survey 2 data also showed a discernable long trench scar that was closely aligned with the inter-array cable that was installed during Phase 2. This trench mark is approximately 3 m (9.84 ft) wide, and varies between 5 and 20 cm (1.97 and 7.87 in) in depth. No new additional disturbance features beyond those reported after Surveys 1 and 2 were identified during Survey 3.

Survey 4 data indicated that approximately 70 percent of the disturbances associated with Phase 1 construction activities were either almost completely (≥ 75 percent filled in), or partially recovered through sediment infilling. The other 30 percent of the features did not appear to have undergone any significant change from observations made during Survey 3. Similarly, approximately 91 percent of the disturbances associated Phase 2 construction activities appeared to be close to completely recovered (≥ 95 percent filled in) or have showed some level of sediment infilling. The remaining 9 percent of the Phase 2 construction activity disturbances did not appear to have undergone any significant change from observations made during Survey 4.

Survey 5 data indicated that approximately 44 percent of the Phase 1 construction activity disturbance features were completely recovered. Approximately 38 percent of the features showed some recovery and the remaining 18 percent showed no significant recovery since Survey 4. Similarly, approximately 69 percent of the disturbances associated with Phase 2 construction activities were completely recovered, 27 percent of the features showed some recovery, and 4 percent showed no significant change from observations made during Survey 4.

2.7.2 Seafloor along the Cable Trench Routes

Cable trench area survey lengths and seafloor recovery percentages are summarized in **Table 7**. Seafloor recovery patterns associated with the inter-array cable and export and transmission cable are shown in **Figures 5** and **6**.

Table 7. Summary of Cable Trench area seafloor recovery

	Survey Date	Post-lay Survey Length (km)	Trench Length Recovered (Percentage)
Inter-array Cable	Survey 1 (May 2016)	Pre-lay (no cable installed)	–
	Survey 2 (October 2016)	4.6	0.8 (17%)
	Survey 3 (May 2017)	4.6	1.6 (35%)
	Survey 4 (October 2017)	4.6	1.8 (39%)
	Survey 5 (September 2018)	4.6	1.9 (41%)
Export Cable (Wind farm to Block Island)	Survey 1 (May 2016)	Pre-lay (no cable installed)	–
	Survey 2 (October 2016)	9.1	5.6 (62%)
Transmission Cable (Block Island to mainland)	Survey 1 (May 2016)	Pre-lay (no cable installed)	–
	July 2016 Survey	19.4	0.5 (3%)
	Survey 2 (October 2016)	31.2	3.7 (12%)
Total		44.9	11.2 (25%)

2.8 Seafloor Recovery Rates

Seafloor recovery primarily occurs because of sediment mobility, which results from bottom currents that 1) transport sediments that infill disturbance features and/or 2) creation, shifting, or migration of bedforms such as ripples and dunes. Current speeds, flow direction, and duration influence sediment transport and bedform creation, shifting, and migration, as previously reported by Allen (1982), Van Rijn (1993), Stow et al. (2009), and Ashley (1990). Seafloor recovery rates also vary with the seafloor sediment type, which influences sediment mobility. Therefore, seafloor recovery characteristics in different regions within the BIWF survey area were expected to be different.

Data from the five surveys were compared to identify regions within the survey area where bedform changes were observed over time. Changes in bedform characteristics such as type, size, and orientation were tracked over time to better understand sediment mobility and seafloor recovery rates. In general, areas where the bedform changes were most notable appeared to have recovered more quickly.

Data interpretation indicated that on the seafloor around Turbine 2, and in the stretch between Turbine 3 and 4, dune-scale bedforms (0.5 to 1.5 m [1.64 to 4.92 ft] tall) shifted to the northwest by the following magnitudes:

- 2.5 to 6 m (8.2 to 19.69 ft) between Surveys 1 (May 2016) and 3 (May 2017),
- Approximately 3 m (9.84 ft) between Surveys 3 (May 2017) and 4 (October 2017),
- Approximately 2 m (6.56 ft) between Surveys 4 (October 2017) and 5 (September 2018), and
- A total of approximately 11 m (36.09 ft) between Surveys 1 and 5.

There was a change in size and/or orientation of several large ripple fields between the surveys. Ripple crestlines observed in Surveys 1, 3, and 4 were primarily oriented east-west, whereas in Survey 2, they were observed to be generally oriented northeast-southwest. Ripple size also changed over time from approximately 10 cm (3.94 in) tall in Surveys 1 and 3, 5 cm (1.97 in) tall in Survey 2, and up to 20 cm (7.87 in) tall in Survey 4. The increase in spatial extent and size of ripples observed in Survey 4 and the east-west reorientation could be attributable to the passage of Hurricane José through the survey area at the end of September 2017.

Ripple crestlines generally retained an east-west orientation except for the area around Turbine 1, where the orientation was northeast-southwest, and the area around Turbine 4, where a combination of the two orientations was observed. In addition, ripple height in Survey 5 was reduced to approximately 10 cm (3.94 in) tall, as compared to the 20 cm (7.87 in) recorded during Survey 4.

Sediment type (e.g., grain size) information for various sections of the survey area was inferred based on data provided by Deep Water, MBES backscatter data collected during Survey 5, and benthic sampling data conducted under the RODEO Program. Correlation between the backscatter data with previously acquired side scan sonar data and grain size data allowed interpretive boundaries to be established. Areas that displayed a high intensity on the backscatter indicate a harder return, which was suggestive of coarse material. Conversely, areas that experienced a lower intensity (soft return) suggested finer-grained material such as fine sands.

Data interpretation indicated that seafloor recovery rates are variable across the survey area, and appear to be primarily related to seafloor sediment type and morphology. The contrast between recovery rates can be abrupt over short distances, as observed near Turbine 4 where two of the L/B Brave Tern spud depressions have completely recovered and two are still discernable. The horizontal distance between the completely and partially recovered spud depressions is only approximately 150 m (492.13 ft), which suggests that sediment type is a primary factor influencing sediment reworking and seafloor recovery.

Some seasonal influence on seafloor recovery rates was also evident because the bedforms were shown to vary both in size (dune and ripple scale) and orientation. From May 2016 to May 2017, orientation and location of individual bedforms appeared to have changed. Ripple fields changed in spatial extent, and ripples also changed in orientation and size between Surveys 1 and 2 and then again between Surveys 2 and 3. Ripples were two times taller in Surveys 1 and 3 (conducted at the end of winter) than observed in Survey 2 (conducted at the end of summer).

These bedform changes were primarily responsible for the varying levels of observed disturbance feature sediment infilling. Changing seasons also seemed to have influenced the sediment mobility, which, in turn, influenced rate of seafloor recovery.

Based on bedform morphology and its changes over time, the survey area was divided into three zones; each zone was characterized by a different seafloor recovery rate (high, moderate, and low rates):

- **Zone 1 – High Seafloor Recovery Rate.** This zone is characterized by abundant ripples that appeared to change in size, extent, and orientation between the surveys. Seafloor sediment type is predominantly medium- to coarse-grained sands with low fine-grained sediments (particle size less than 0.075 millimeter [mm] [0.04 in]). Side scan sonar reflectivity is high, and MBES backscatter intensity values are typically between -20 and -25 decibels. Seafloor disturbance recovery rates were approximately 2.5 times higher than in Zone 2.
- **Zone 2 – Moderate Seafloor Recovery Rate.** This zone is characterized by sand accumulation areas that appeared to be migrating over coarser sediments. The side scan sonar reflectivity is generally low, and MBES backscatter intensity values are typically between -27 and -30 decibels. Sediment type is inferred to be predominantly fine- to medium-grained sand with a low amount of fine-grained sediment (particle size less than 0.075 mm [0.04 in]). The sand accumulation bodies are approximately 0.5 to 1 m (1.64 to 3.28 ft) tall, and fall within a dune scale size.
- **Zone 3 – Low Seafloor Recovery Rate.** This zone contained the coarsest seafloor sediment and slowest recovery. Seafloor sediment predominantly consists of sand, gravel, and cobbles. This zone is confined to the southwest portion of the survey area and no turbines or cables were installed in this zone.

Seafloor recovery estimates per zone is summarized in **Table 8** and **Figure 7**.

Table 8. Seafloor recovery per zone

Recovery Zone	Percentage of Disturbed Area Completely Recovered at Time of Survey 5	Comment
Zone 1 – High Seafloor Recovery Rate	82%	Area of dynamic ripples and predominantly medium- to coarse-grained sand
Zone 2 – Moderate Seafloor Recovery Rate	32%	Area of ripple to dune scale bedforms and predominantly fine-grained sand
Zone 3 – Low Seafloor Recovery Rate	0%	Coarse sand, gravel, and cobbles

2.9 Overview of Spatial Extent of Seafloor Disturbances in the Wind Farm Survey Area

The spatial extent of seafloor disturbance surrounding the turbines was evaluated. Results indicated that, in general, most of the seafloor disturbance occurred within an approximately 300 to 600 m (984.3 to 1,968.5 ft) wide corridor. This finding may be used to guide defining the size of construction corridors where construction equipment is permitted to disturb the seafloor.

Currently in the U.S., marine archaeological resource assessment surveys of all areas potentially affected by construction are required prior to conducting activities (e.g., construction, geotechnical exploration) that will disturb the seafloor. If the surveys and subsequent construction activities could be constrained to corridors in the wind farm, then this could result in a reduction of the amount of area surveyed, and ultimately, in the time and costs associated with the surveys.

The BIWF construction activities were not confined to a defined corridor, but were restricted to an area referred to as the Work Area, which was surveyed under this monitoring program. Therefore, seafloor disturbances identified outside the corridors discussed herein do not necessarily indicate that a corridor approach is not feasible. However, developers would need to carefully consider the corridor width required for their equipment.

3 Scour Assessment

Scour, which is a type of erosion, is generally defined as the removal of granular bed material in the vicinity of hard coastal structures by hydrodynamic forces such as waves, currents, and tides. When any hard structure, such as a wind turbine steel foundation, is placed on the seafloor it influences near-bottom current flows, which may lead to scouring of the seafloor in the vicinity of the structure. The scouring action may adversely affect naturally occurring benthic habitat; it may also compromise the integrity and/or functionality of the hard structure.

An innovative approach using real-time scour monitors was field tested at the BIWF to characterize scour resulting from placement of turbine foundations on the seafloor. Scour associated with the concrete mats, which were placed on the seafloor for protection of unburied sections of the submarine power transmission cables,² was assessed using the high-resolution bathymetry survey data. Results and conclusions from the scour assessment may be used to guide design of field studies for monitoring scour conditions at future offshore wind farm facilities.

3.1 Turbine Foundation Scour Assessment

3.1.1 Approach and Methods

Two innovative scour monitors (**Figure 8**) were installed on the foundation of Turbine 3, and changes in seafloor levels (scouring patterns) near this foundation were tracked in real time over an approximately 14-month period.³ The units were serviced every 3 months. A frame-mounted acoustic wave and current profiler (AWAC) also was simultaneously deployed on the seafloor approximately 500 m (1,640.4 ft) southeast of Turbine 3 (**Figure 8**). Site-specific oceanographic data collected by the AWAC supported analyses and interpretation of data obtained from scour monitors.

Table 9 and **Figure 9** show the instrument deployment locations and dates. Following the deployment in June 2016, the monitors were serviced in November 2016, March 2017, and October 2017. **Figure 10** is a schematic illustrating the position of the scour monitors on the turbine foundation.

Table 9. Locations of turbine scour monitoring equipment.

Location Name	Latitude (WGS84)	Longitude (WGS84)	UTM Coordinates (NAD83 Zone 19 N)	Deployment Date
AWAC	41° 06' 34.5" N	071° 31' 00.5" W	288674.5 m E, 4553973.8 m N	15 June 2016
Anchor Weight	41° 06' 36.2" N	071° 31' 01.1" W	288662.0 m E, 4554026.6 m N	15 June 2016
Scour Monitors (Turbine 3)	41° 06' 54.0" N	071° 31' 15.6" W	288339.6 m E, 4554585.4 m N	28 July 2016

The following types of data were collected using the scour monitors:

- Continuous acoustic return data along four beams per instrument.
- Seafloor elevations at distances up to 10 m (32.8 ft) from the foundation.

² Sections of the power transmission cable were intentionally left unburied near the steel foundations to allow the cable to be pulled into the turbine structure.

³ Scour monitor data were collected for 14 months and 19 days; AWAC data were collected for 16 months and 3 days.

- Changes in the seafloor elevations over a variety of periodicities:
 - Less than 1 day, consistent with the periodicity of the local tidal forcing.
 - Over the course of a week to a month, appearing to coincide with perturbations to the tidal current flow resulting from increased wave energy.
 - A seasonal signal consistent with increased wave activity in the winter months, and calmer conditions in the summer months.
- The orientation of the acoustic beams also allowed observation of the variation in seafloor level with distance from the foundation, and response of the seafloor to physical oceanographic forcing.

3.1.2 Results

A comprehensive dataset of seafloor elevations adjacent to the turbine foundation and associated oceanographic data (e.g., water levels, currents, and waves) was generated by the study. These data were analyzed to improve understanding of factors that influence scouring rates and patterns. Long- and short-term trends in seafloor elevations determined through the analyses of data collected by the scour monitors and the AWAC data are presented below; additional details are contained in the technical report shown in **Appendix H**.

3.1.3 Short-term Trends

Short-term trends showed the seafloor level responding to changing oceanographic conditions. Bed levels appeared to fluctuate by up to 0.2 m (0.7 ft) with tidal conditions. The current flow in the BIWF development responds to increased wave action, which significantly alters the flow pattern around the structure, leading to a change in the seafloor topography at or close to the structure.

Data indicated that the seafloor scour level generally is deepest closest to the structure and gets shallower progressively with distance from the foundation. Variability of approximately 0.2 m (72.2 ft) over 12 to 24 hours is seen in August data and tends to occur in line with the tidal forcing, being most obvious during the period when the net current flow is from the northeast toward the southwest. The presence of an area of sand ripples that are migrating into the area around the foundation during the summer months has been observed in bathymetric surveys (Survey 3) conducted within the Survey Area. Ripples that are approximately 0.1 to 0.2 m (0.4 to 0.7 ft) tall (peak to trough) were inferred to be dynamic in the area surrounding the monitoring site.

During periods of increased wave activity, the seafloor level showed reduced variation. Further work is needed to understand the mechanism for this phenomenon; however, it is possible that the local seafloor morphology changes and the sand ripples that migrate across the site during calm conditions are leveled by the increased seafloor disturbance.

3.1.4 Long-term Trends

Mean scour depth of each beam per month is shown in **Figure 11**, and a summary mean scour profile is presented in **Figure 12**. Beam 1 was orientated at an angle of 5° and, therefore, represents measurements taken closest to the turbine. In contrast, beam 4 was orientated at an angle of 20°, and it represented measurements taken farthest from the turbine.

The range of seafloor levels (monthly maximum and minimum) exhibited a variation of up to 0.6 m (2 ft) over the month. Some correlation between the greatest levels of scour and the highest significant wave heights, as measured by the AWAC, was evident. It is possible that increased wave action during the winter and early spring led to reductions in seafloor level. Some recovery of the seafloor level was seen,

particularly on the southeast leg. This may be attributable to increased deposition of sediments following winter conditions close to the foundation. The northeast unit showed a small recovery of the mean seafloor level (<0.1 m [0.3 ft]) during the summer months, July to September, but it did not recover to the levels observed at the start of monitoring surveys.

3.2 Concrete Mat Scour Assessment

3.2.1 Approach and Methods

Scour associated with the turbine legs was also evaluated using the multibeam survey data collected during the bathymetry surveys. This evaluation indicated scour depths of 10 to 25 cm at the turbine legs, with the deepest scours observed at the Turbine 1 and 2.

Note that bathymetry survey data provide only an instantaneous snapshot of scour conditions at a given location at a given point in time. The scour monitors on the other locations provided continuous data on monthly and seasonal scour development, infill processes, and seafloor elevation changes during storm events—information that cannot be gleaned from conducting multibeam surveys at scattered intervals.

3.2.2 Results

Bathymetry survey data indicated that small erosional features had developed adjacent to east-west oriented mats at Turbines 1 and 2. The scour features were up to approximately 5 to 25 cm (1.87 to 9.84 in) deep, and extended approximately 1 to 3 m (3.28 to 9.84 ft) from the mats. The scour features were notably larger on the northwest side of concrete mats. The east-west oriented concrete mats were nearly perpendicular to the principle tidal axis, which was inferred to be north-northwest–south-southwest direction. The bias of scour development to the north-northwest suggest the flood tidal currents are dominant in the area of Turbines 1 and 2.

Sections of cable and mats oriented north-south did not appear to exhibit scour. The extent and depth of scour did not appear to change significantly between Surveys 3, 4, and 5. Scour was not observed adjacent to concrete mats at the other three turbines (Turbines 3, 4, and 5).

3.3 Conclusions and Lessons Learned

Key inferences from the scour assessment are listed below:

- The two scour monitors functioned as planned. A near-continuous seafloor elevation dataset was collected over the 14 months and 19 days.
- The seafloor-mounted AWAC also functioned as planned. A near-continuous oceanographic condition (e.g., water levels, currents, and waves) dataset was collected over the 16-month and 3-day deployment period.
- The following issues were encountered with the scour data:
 - Orientation of the scour monitor on the southeast leg meant the data were collected closer to the foundation than planned.
 - Corruption of one scour monitor beam on the southeast leg occurred during the final 3 months, probably because of interference from the structure.
- Lessons learned:
 - Early interaction with the construction team was vital to allow bracketing to be mounted and orientated correctly.

- At sites with a strong seasonal thermocline, it is essential for long-term variation in the seafloor levels to be calculated using a speed of sound derived from a model of (or average of) the conditions between the scour monitor and the seafloor. In this case, the presence of a strong summer thermocline caused errors in the initial range calculations. Vertical conductivity, temperature, and depth profiles taken in the summer months showed that the thermocline depth was approximately midway between the scour monitor and the seafloor. Thus, the average speed of sound between the scour monitor and the seafloor AWAC was calculated and used to correct the acoustic ranges.
- Future opportunities:
 - The scour monitors provide a long-term time series of seafloor elevations at specific points close to the foundation (in this case, up to 10 m [32.8 ft]) that can be used to enhance the understanding of the variation in seafloor levels.
 - The scour monitors allow measurement of the seafloor response in conditions where bathymetric surveys are not feasible.
 - For future sites, the scour monitors could be used at a limited selection of foundations to support the assumptions about seafloor mobility made during design, or if scour occurs under specific circumstances, appropriate preventive intervention can be designed and actioned to maximize the life of the structures.

4 Seafloor Disturbance and Recovery Monitoring Conclusions

The overall conclusion from monitoring surveys was that 1) a relatively small area of the seafloor off Block Island was disturbed by wind farm construction activities, and 2) much of the disturbed area fully recovered within a relatively short time.

Key results and major conclusions from the monitoring surveys are summarized below:

- Wind farm construction activity was confined to a relatively small section of the seafloor off Block Island, which was designated as the Work Area. This area measured approximately 7,277,390 m²; 1,798.3 ac). Within the Work Area,
 - Phase 1 construction activities directly affected approximately 11,570 m² (2.9 ac) of seafloor, which is less than 0.2 percent of the total Work Area. *The seafloor impact was therefore roughly equal to the area occupied by two football fields.* It is important to note that the 11,570 m² (2.9 ac) of affected area was distributed between 160 discrete and geographically scattered features—26 spud marks (1,102 m² [0.27 ac]), 69 circular depressions (2,803 m² [0.69 ac]), 44 drag marks (6,414 m² [1.58 ac]), and 21 scour features (1,251 m² [0.31 ac]).
 - The impact of Phase 2 construction on the seafloor was even less, affecting approximately 6,876 m² (1.7 ac) and consisting of 101 features—37 spud marks (4,152 m² [1.03 ac]), 51 circular depressions (1,595 m² [0.39 ac]), and 13 drag marks (1,129 m² [0.28 ac]). In other words, the seafloor area affected by Phase 2 construction activities was only slightly larger than one football field. Note that in addition to the 101 features, two new small scour features also were recorded during Survey 2.
- Outside of the construction Work Area, seafloor impacts associated with the laying of the submarine transmission cable were also limited strictly to the cable route, which, compared to the larger seafloor off Block Island, covered a small area of the seafloor.
- ***Most of the seafloor disturbances directly associated with wind farm construction activities were temporary. Much of the damaged area was observed to completely recover over time through sediment mobility, which results from bottom currents.*** These currents transport sediments that infill disturbance features and/or create, shift, or migrate bedforms such as ripples and dunes, which also contributes towards recovery of the disturbance features.
- Of the 160 disturbance features (covering 11,570 m² [2.9 ac] of seafloor) recorded during the first survey in May 2016, approximately 44.3 percent of the disturbed area (90 features covering approximately 5,122 m² [1.3 ac]) had completely recovered within 36 months (Survey 5 in September 2018), and the remaining 70 features showed partial recovery.
- Of the 101 additional disturbance features (covering an area of approximately 6,928 m² [1.7 ac]) documented during the second survey in October 2016, 70 percent of the disturbed area (86 features covering approximately 4,805 m² [1.2 ac]) had completely recovered within approximately 25 months, and the remaining 17 features covering approximately 2,023 m² (0.5 ac) showed partial recovering.
- Within approximately 4 months of being laid down in June 2016, almost 62 percent of the export cable scar had recovered and the remainder was partially recovered. Approximately 41 percent of the inter-array cable trench scar appeared to have completely recovered by September 2018 (Survey 5), and much of the rest was partially recovered. Twelve percent of the transmission cable scar had recovered within 4 months (Survey 2 in October 2016); the remainder was partially recovered.
- The rate of seafloor recovery was primarily dictated by water depth, existing sediment type, and prevailing current speeds, flow direction, and duration, which influenced both sediment transport

and bedform creation, shifting, and migration. Minor seasonal impacts on seafloor recovery rates were also documented.

- Since seafloor recovery resulting from sediment infilling is dictated by a complex interaction between factors such as water depth, sediment type, and prevailing current speeds, flow direction, and duration, it was anticipated that the seafloor disturbances around the five turbines would recover at different rates. The monitoring data analyses results confirmed this. The monitoring data analyses results confirmed this assumption. Note that the 5 turbines extend only across 2 miles, but even within this relatively small distance there is a difference in the type of seabed and currents.
- Based on bedform morphology, the seafloor within the Work Area was broadly divisible into a high recovery rate zone, a moderate recovery rate zone, and a low recovery rate zone. The rate of recovery in the high zone was almost 2.5 times higher than the rate of recovery in the moderate zone. No turbines or cables were installed in the low recovery rate zone.
- Scour associated with the concrete mats placed on the seafloor to protect the unburied section of the power transmission cables at the turbine entry points was observed only near Turbines 1 and 2. The scour features were approximately 5 to 25 cm (1.97 to 9.84 in) deep, and extended approximately 1 to 3 m (3.28 to 9.84 ft) from the mats. The scour marks were notably larger on the northwest side of concrete mats, which potentially indicated strong influence of a dominant bottom current flow direction.
- Over time, three of the four types of disturbance features documented—namely, spud marks, circular depressions, and drag marks—are expected to fully recover. Some extent of the scour features, on the other hand, is likely to remain as long as the hard structure (turbine foundations and concrete mats) remains in place.
- ***In general, most of the seafloor disturbances associated with construction activities occurred within an approximately 200 m (656.2 ft) area around each turbine. This observation may be used to guide delineation of construction-related direct impact areas for future wind farm facilities in the U.S. Seafloor disturbances associated with construction activities may be permitted only within the defined area.***
- Short-term trends from the real-time scour monitoring showed the seafloor level responding to changing oceanographic conditions. Seafloor levels were observed to fluctuate by up to 0.2 m (0.7 ft) with tidal conditions. Data also indicated that the seafloor scour level is generally deepest closest to the hard structure and gets shallower progressively with distance from the foundation. During periods of increased wave activity, the seafloor level showed reduced variation. Some correlation between the greatest levels of scour and the highest significant wave heights was also evident.
- Long-term trends from the real time scour monitoring indicated a range of up to 0.6 m (2 ft) between the monthly maximum and minimum elevations.
- Scour associated with the turbine foundation legs also was evaluated using the multibeam survey data collected during the bathymetry surveys. This evaluation indicated scour depths of 10 to 25 cm (3.94 to 9.84 in) at the turbine legs, with the deepest scours observed at Turbines 1 and 2. It is important to note that bathymetry survey data provide only an instantaneous snapshot of scour conditions at a given location at a given point in time, whereas the scour monitors provide continuous data on monthly and seasonal scour development, infill processes, and seafloor elevation changes during storm events—information that cannot be gleaned from conducting multibeam surveys at scattered intervals. Both methods are recommended to be used in parallel to better understand scour associated with the offshore turbine foundations.
- The results of the real-time scour monitoring may be used to guide design of field studies for monitoring scour conditions at future offshore wind farm facilities.

5 References

- Allen, J.R. 1982. *Sedimentary Structures: Their Character and Physical Basis*. Elsevier, New York, NY.
- Ashley, G.M. 1990. Classification of Large-Scale Subaqueous Bedforms: A New Look at an Old Problem. *Journal of Sedimentary Petrology*, Vol. 60, pp. 363–396.
- Elliott J., K. Smith, D.R. Gallien, and A. Khan. 2017. Observing Cable Laying and Particle Settlement during the Construction of the Block Island Wind Farm. Final Report to the U.S. Department of the Interior, Bureau of Ocean Energy Management, Office of Renewable Energy Programs. OCS Study BOEM 2017-027. 225 pp.
- Fugro. 2016. Seafloor Disturbance and Recovery Monitoring Program, Survey 1 May 2016. Fugro Project No.04.81150001, prepared for HDR. Issued on September 7, 2016.
- Fugro. 2017a. Seafloor Disturbance and Recovery Monitoring Program, Survey 2 October 2016. Fugro Project No. 04.81150001, prepared for HDR. Issued on June 8, 2017.
- Fugro. 2017b. Seafloor Disturbance and Recovery Monitoring Program, Survey 3 May 2017. Fugro Project No. 04.81150001, prepared for HDR. Issued on June 1, 2017.
- Fugro. 2017c. Seafloor Disturbance and Recovery Monitoring Program, Survey 4 October 2017. Fugro Project No. 04.81150001, prepared for HDR. Issued on November 13, 2017.
- Fugro. 2018. Block Island Wind Farm, Scour Monitor and AWAC Recovery Operation Report, Block Island Wind Farm, USA. Fugro Report No. 160215-5, prepared for HDR. Issued on January 29, 2018.
- Fugro. 2019. Seafloor Disturbance and Recovery Monitoring Program, Survey 5 September 2018, USA. Fugro Report No. 02.81150001-5, prepared for HDR. Issued on August 23, 2019.
- HDR. 2018. Field Observations during Wind Turbine Foundation Installation at the Block Island Wind Farm, Rhode Island. Final Report to the U.S. Department of the Interior, Bureau of Ocean Energy Management, Office of Renewable Energy Programs. OCS Study BOEM 2018-029. 175 pp.
- HDR. 2019. Field Observations during Wind Turbine Operations at the Block Island Wind Farm, Rhode Island. Final Report to the U.S. Department of the Interior, Bureau of Ocean Energy Management, Office of Renewable Energy Programs. OCS Study BOEM 2019-028. 281 pp.
- Stow, D.A.V., Hernández-Molina, J., Llave, E., Sayago-Gil, M., Díaz del Río, V., and Branson, A. 2009. Bedform-velocity matrix: The estimation of bottom current velocity from bedform observations. *Geology*, 37:4, pp. 327–330.
- Van Rijn, L.C. 1993. *Principle of Fluid Flow and Surface Waves in Rivers, Estuaries, Seas, and Ocean*. Aqua. Amsterdam, The Netherlands.
- Wilson, J.C. 2007. Offshore wind farms: their impacts, and potential habitat gains as artificial reefs, in particular for fish. *Estuarine and Coastal Science and Management*, UK.

Appendix A: Field Plan

The field plan was provided as Appendix A in the report entitled “*Field Observations during Wind Turbine Foundation Installation at the Block Island Wind Farm, Rhode Island*” (HDR 2018).

Appendix B: Figures



Figure 1. Location of BIWF Turbines.

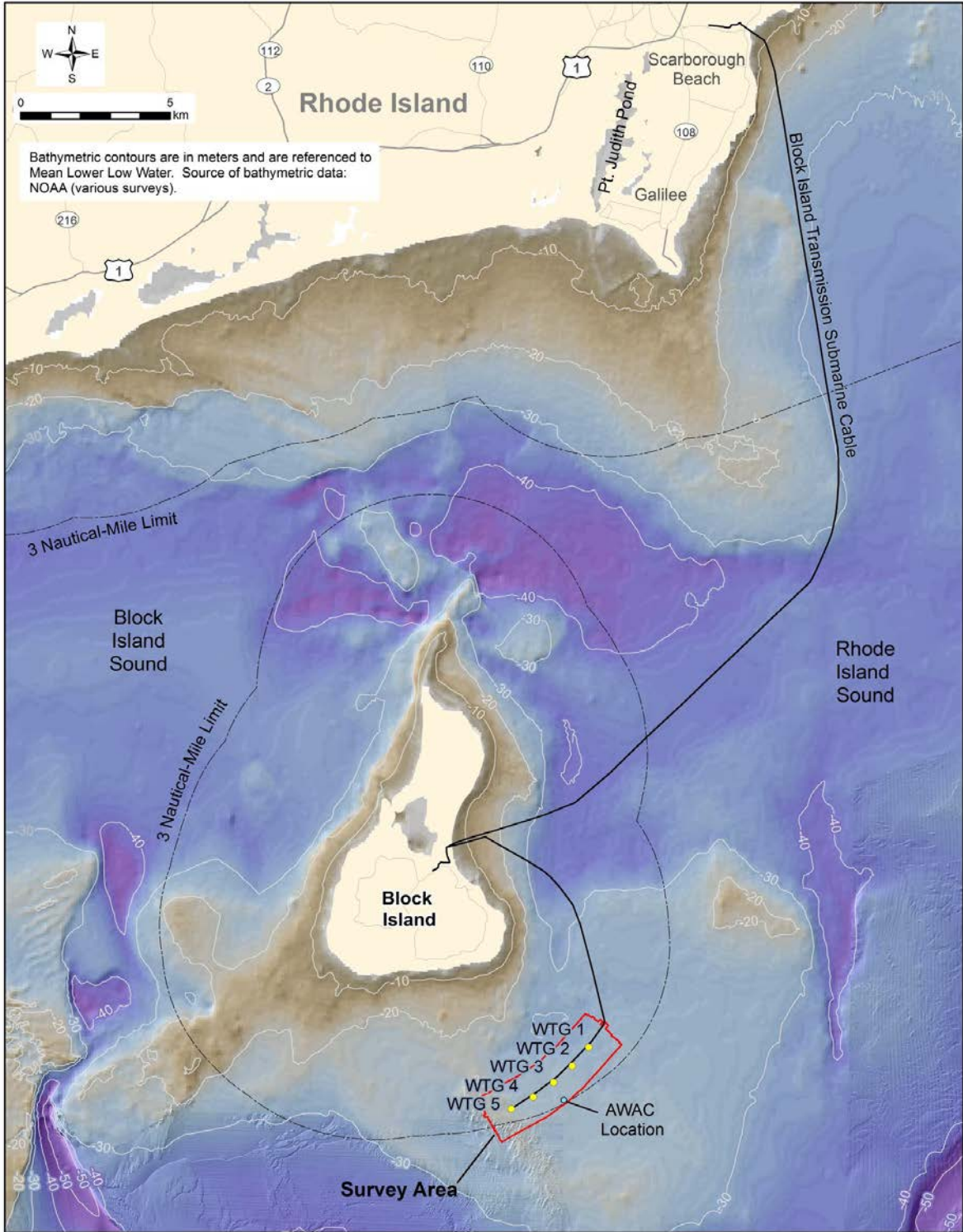

Figure 2. BIWF Survey Area.
 Note: The red box denotes the “Work Area” that was surveyed.

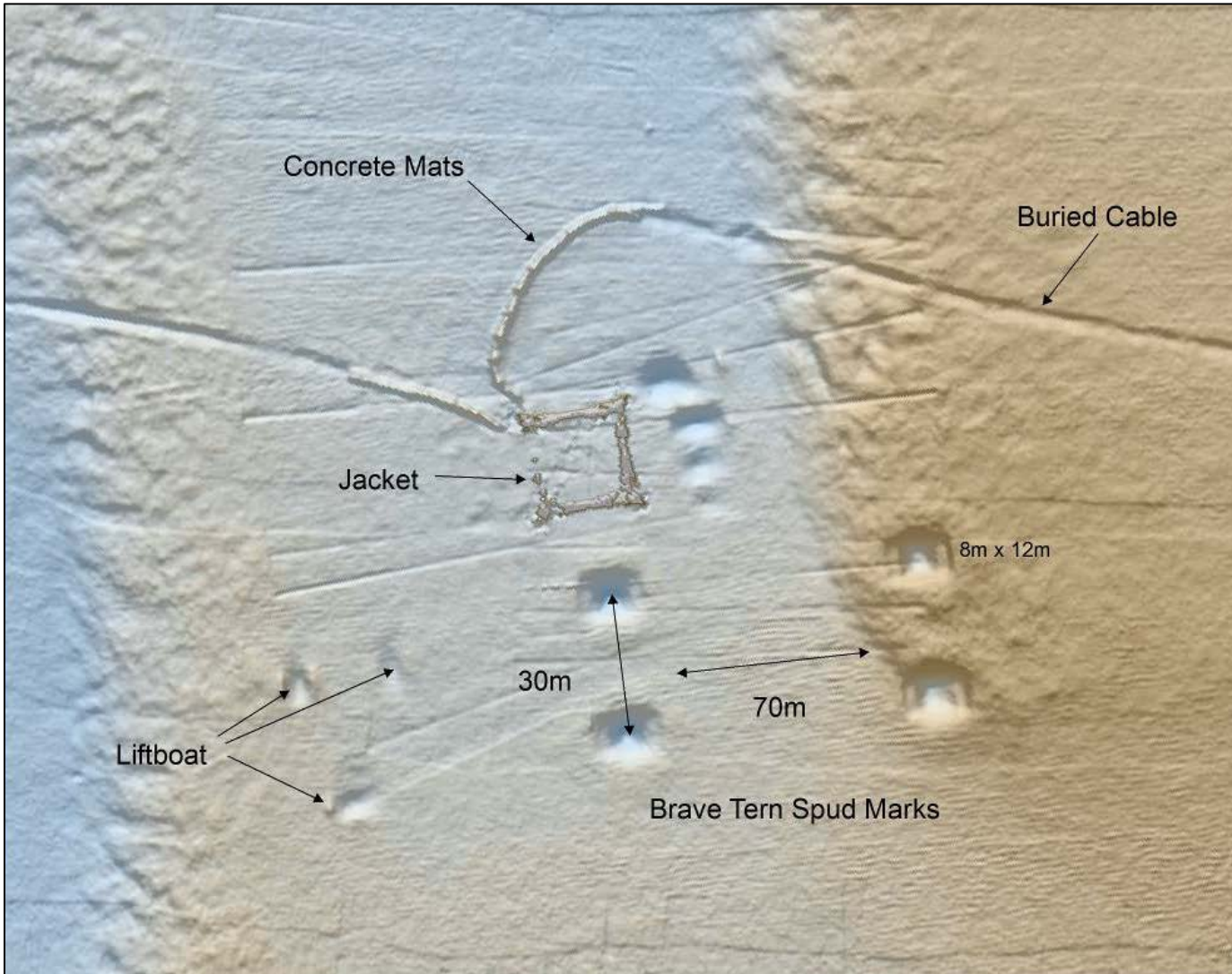

Figure 3. Examples of seabed disturbance features.

Note: Features shown in Figure 3 were observed near Turbine 4 during Survey 2.

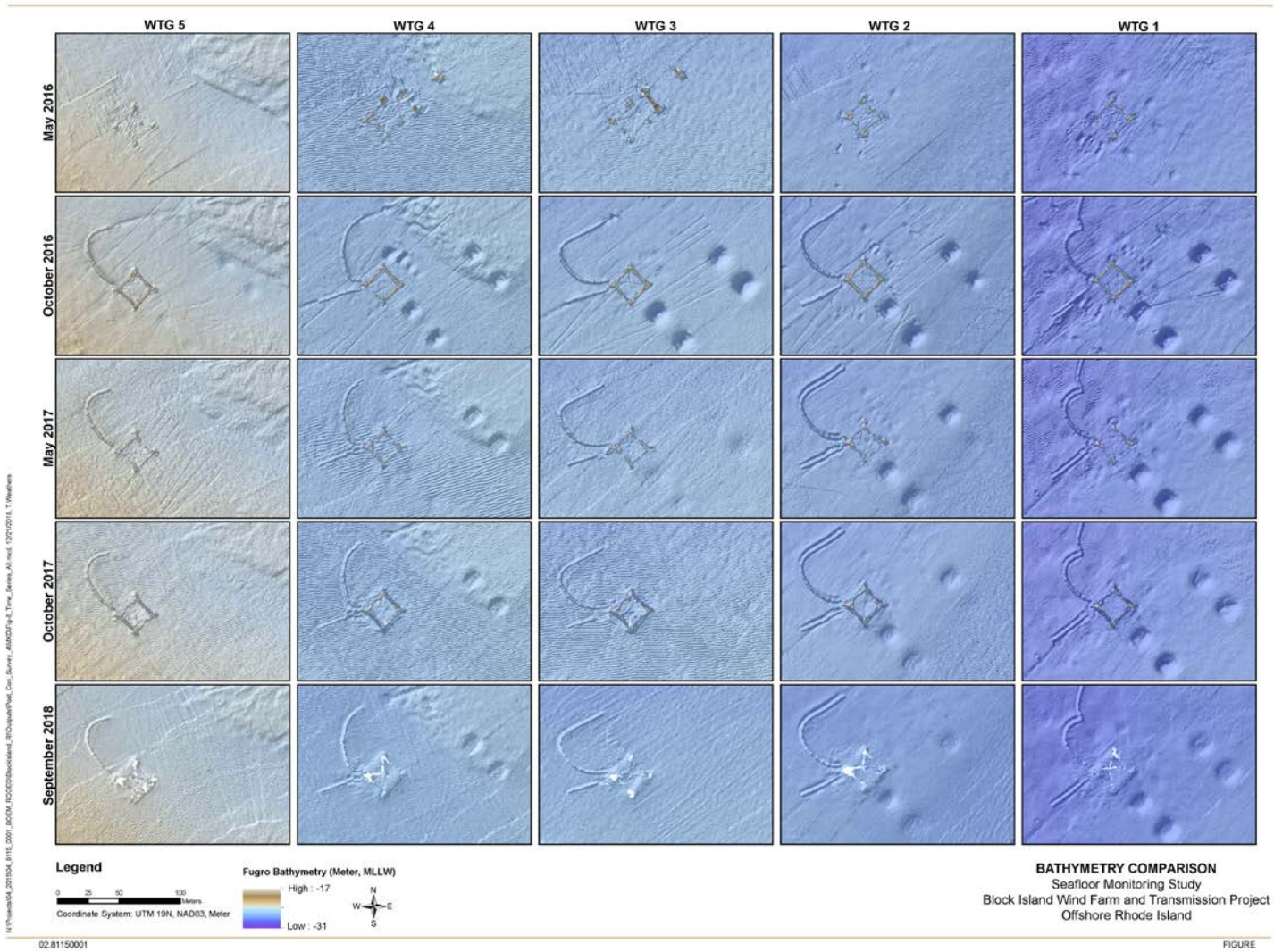
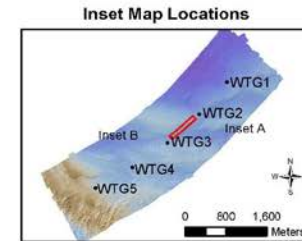
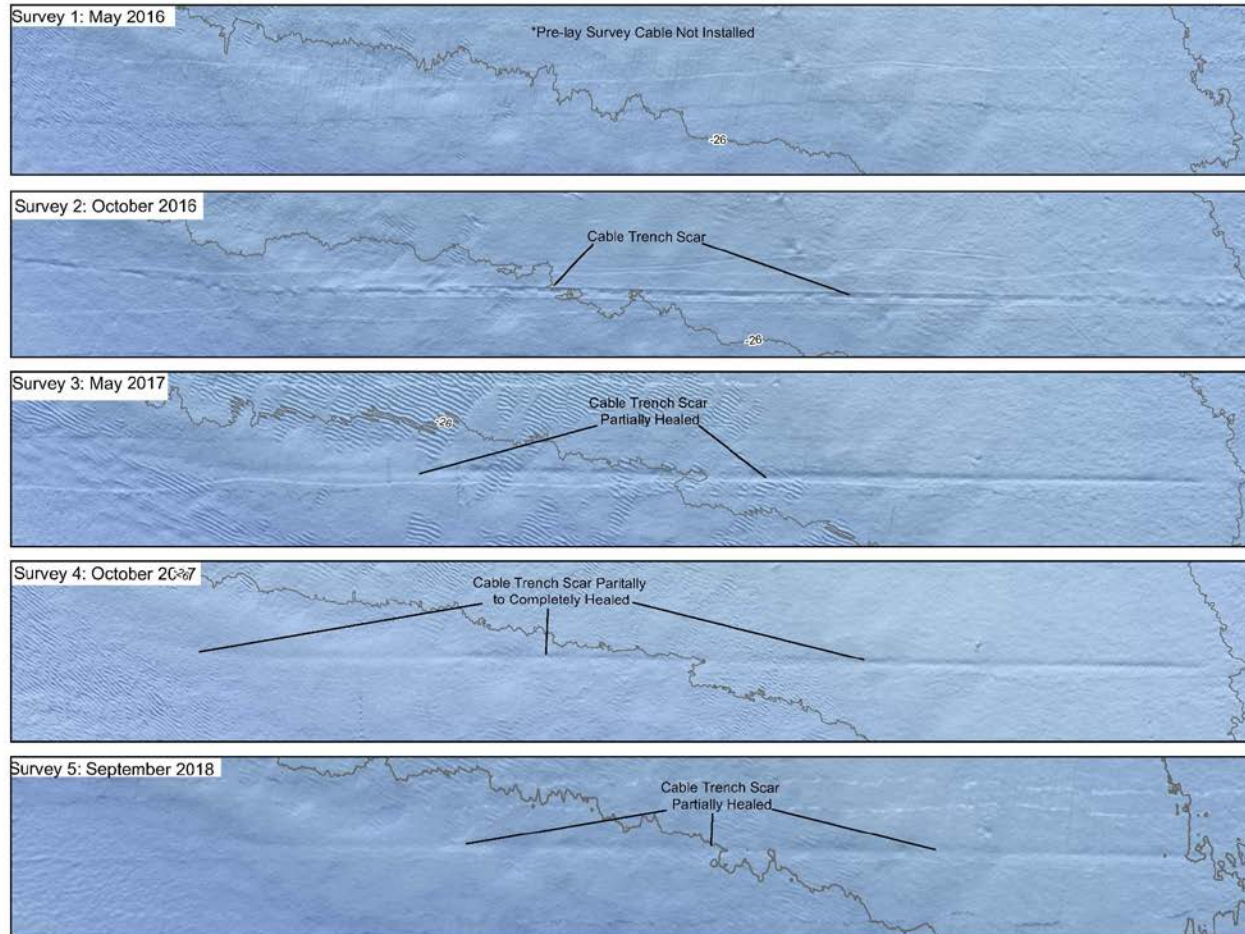
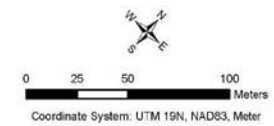

Figure 4. Time series from Survey 1 (May 2016) to Survey 5 (September 2018) for each Turbine, depicting seafloor disturbance and recovery.



Notes:

The comparison of the inter-array cable from the four surveys (May 2016 through October 2017), indicate that cable trench scar has partially healed. The inter-array cable was installed between June and July 2016, and Survey 2 (Oct. 2016) showed that the trench scar was up to approximately 10 cm in depth in this area. Survey 3 (May 2017) showed in this same area that portions of the cable trench had completely healed while other areas were up to 7 cm deep. Survey 4 (Oct. 2017) showed that most of the cable trench in this extent had healed, with a few areas up to approximately 5 cm in depth.



**INTER-ARRAY CABLE TRENCH
MAY 2016 THROUGH SEPTEMBER 2018 SURVEYS**
Seafloor Monitoring Study
Block Island Wind Farm and Transmission Project
Offshore Rhode Island

Figure 5. Inter-array cable trench seafloor recovery patterns.

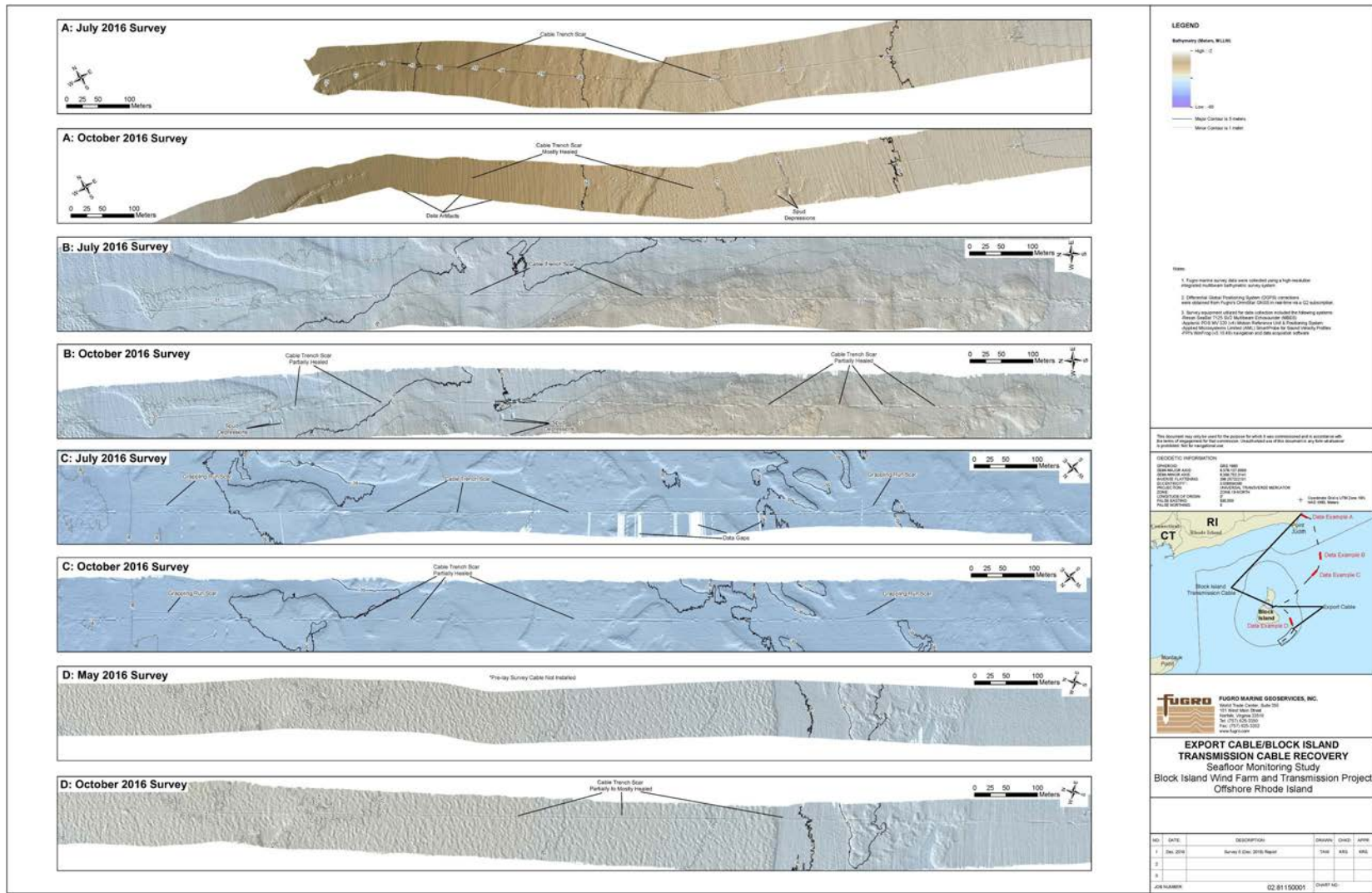

Figure 6. Export and transmission cable trench seafloor recovery patterns.

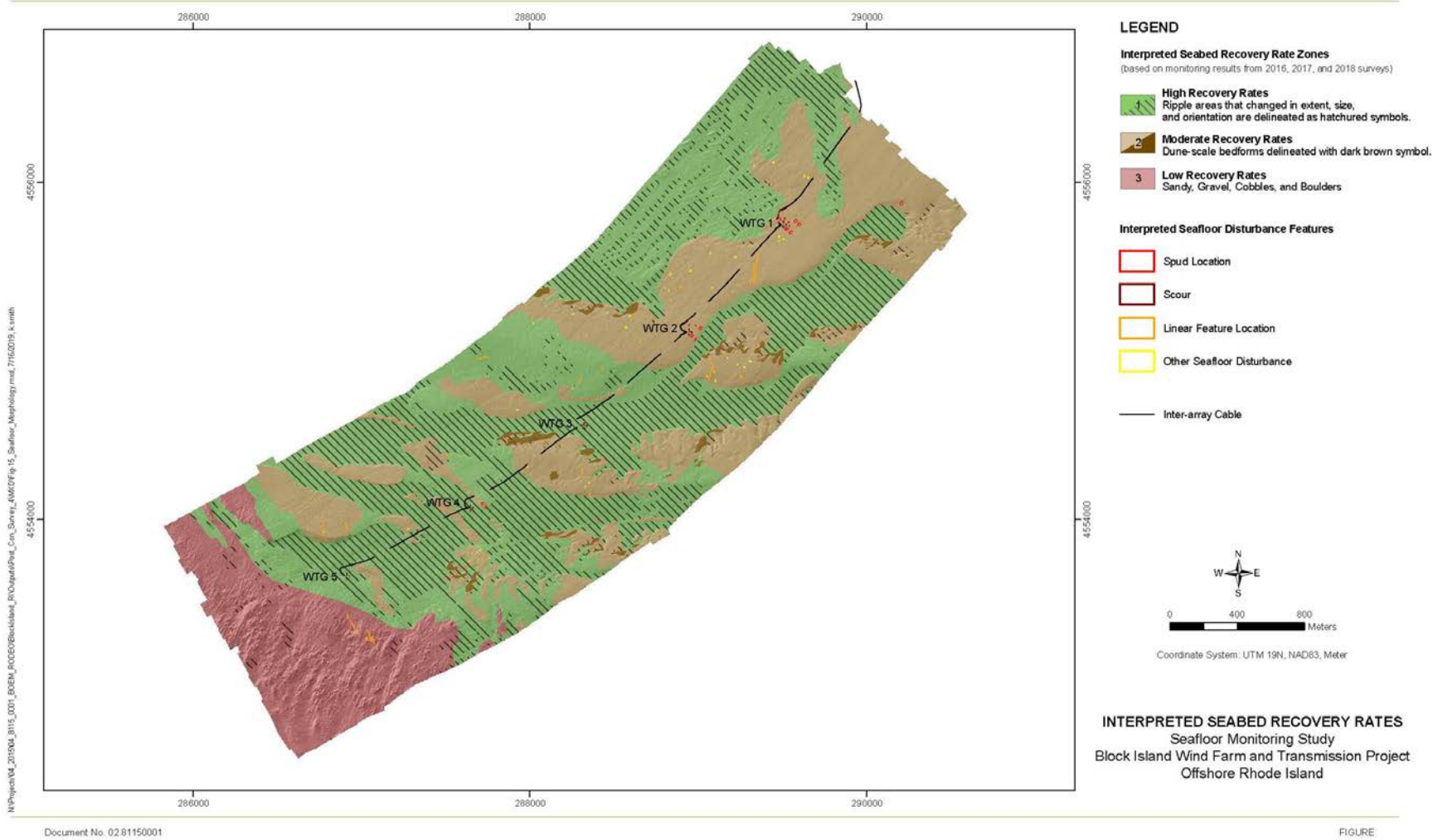

Figure 7. Interpreted sea floor recovery rates over the five surveys.



Figure 8. Scour monitor in bracketing (top); seafloor frame and AWAC (bottom).

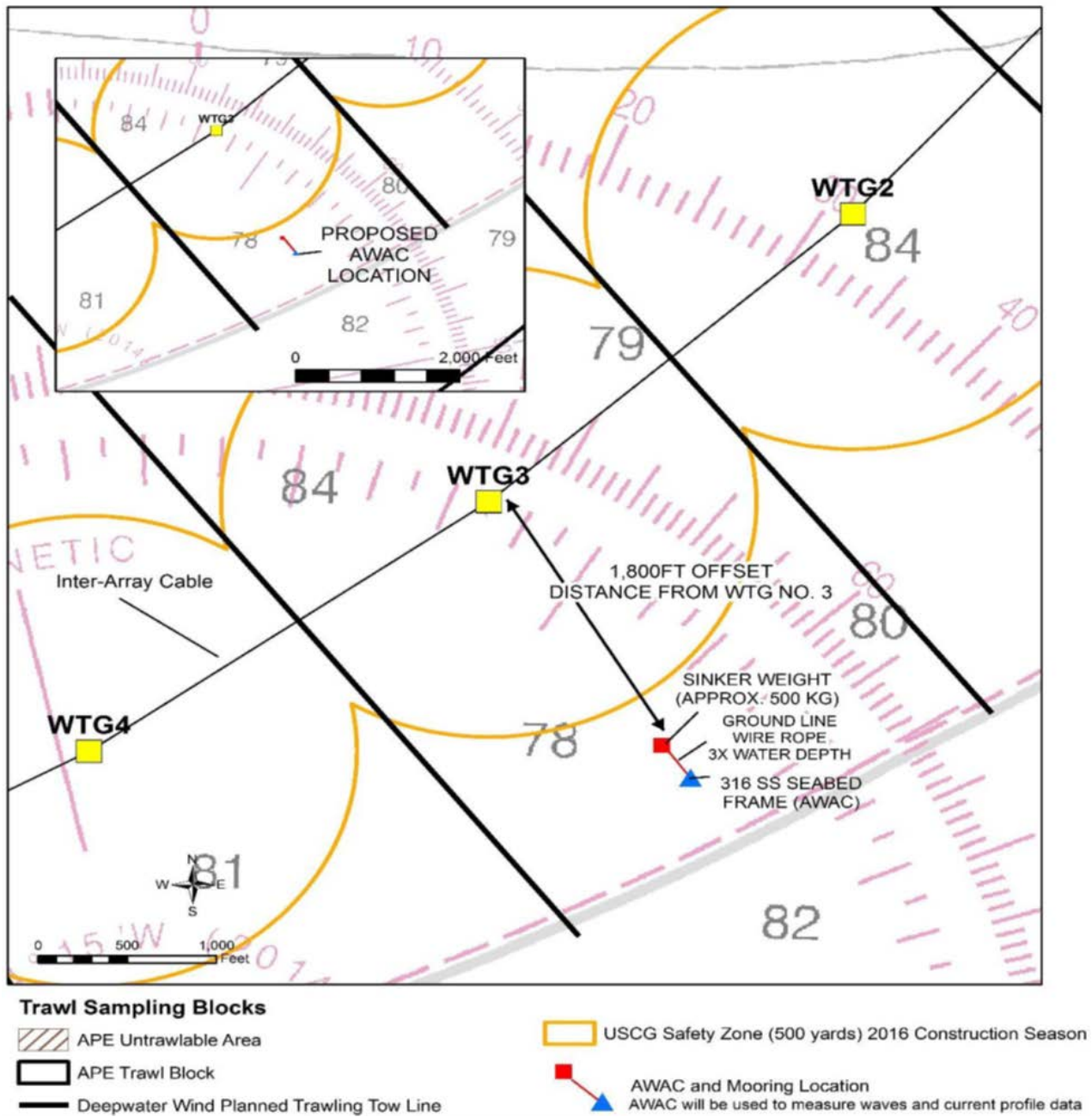

Figure 9. Location of deployed equipment.

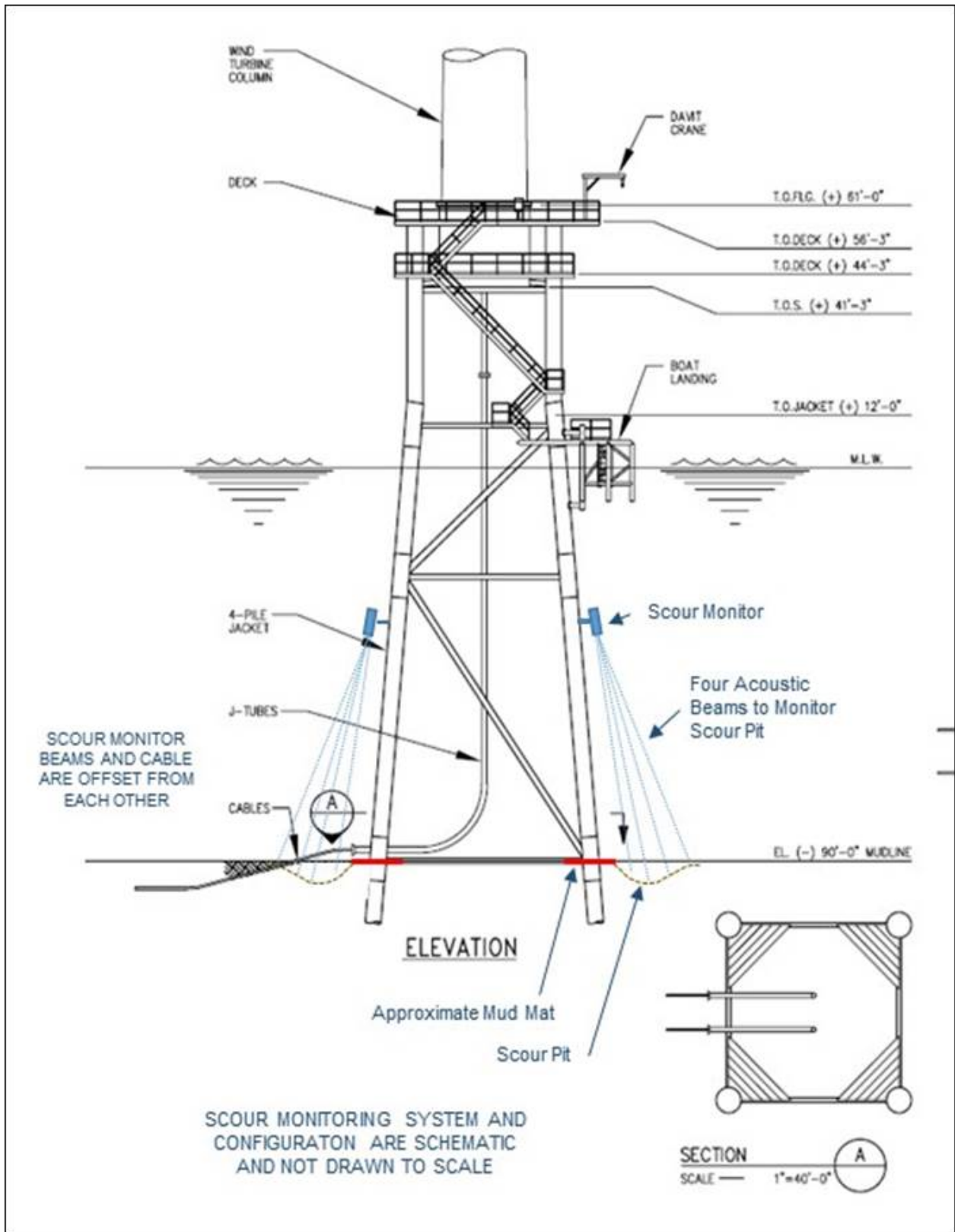

Figure 10. Positioning of the scour monitors on the turbine foundation.

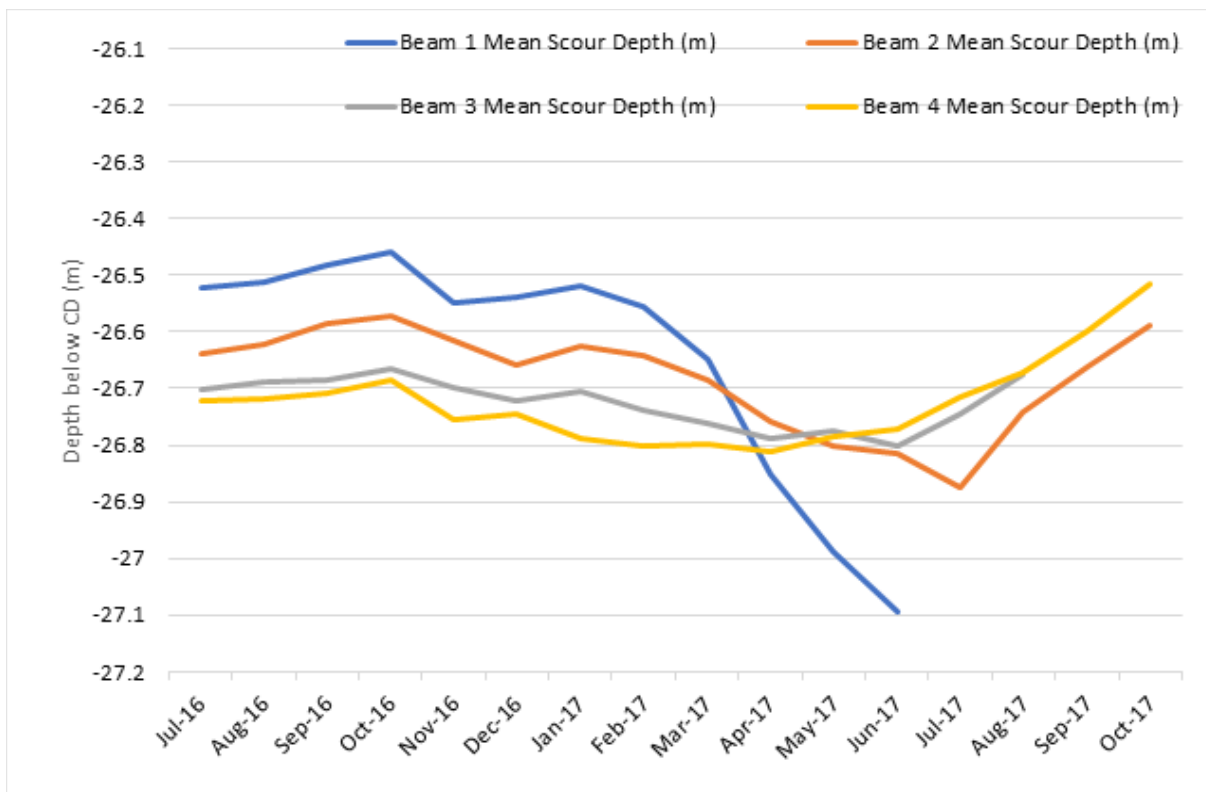
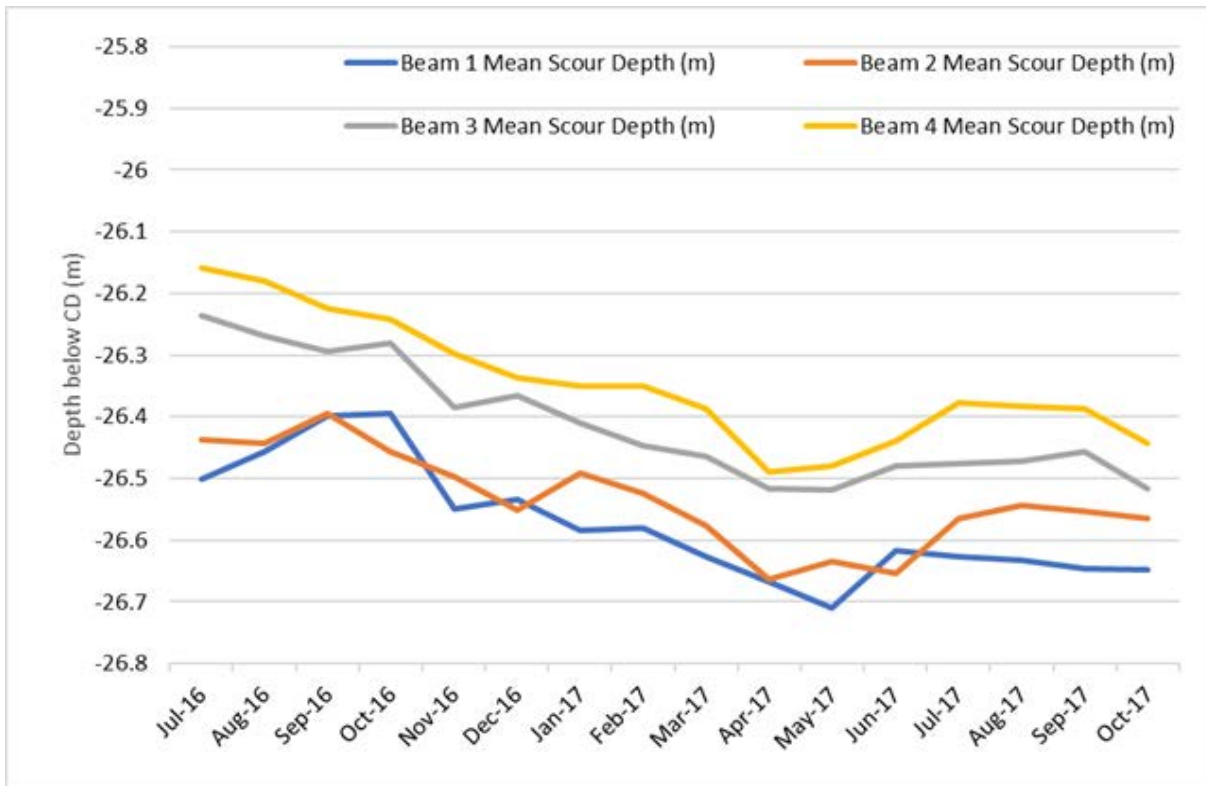

Figure 11. Mean scour depth of each beam per month.

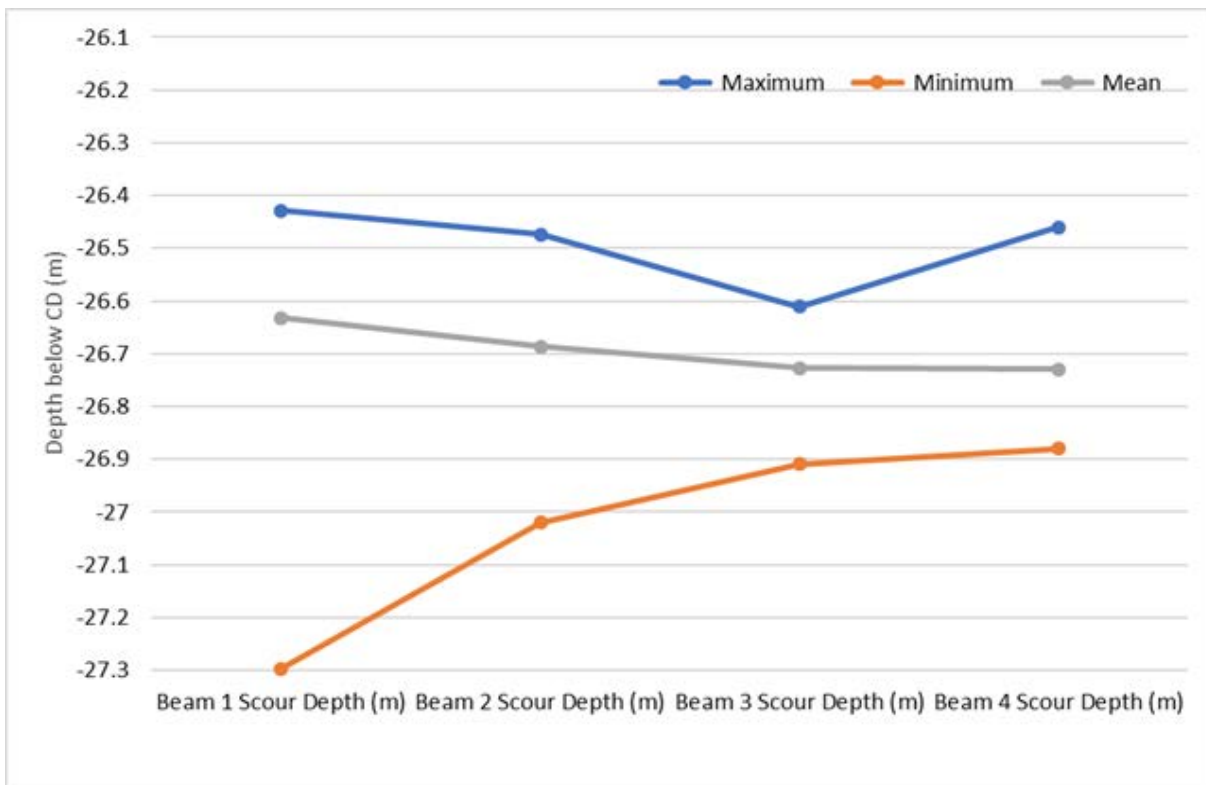
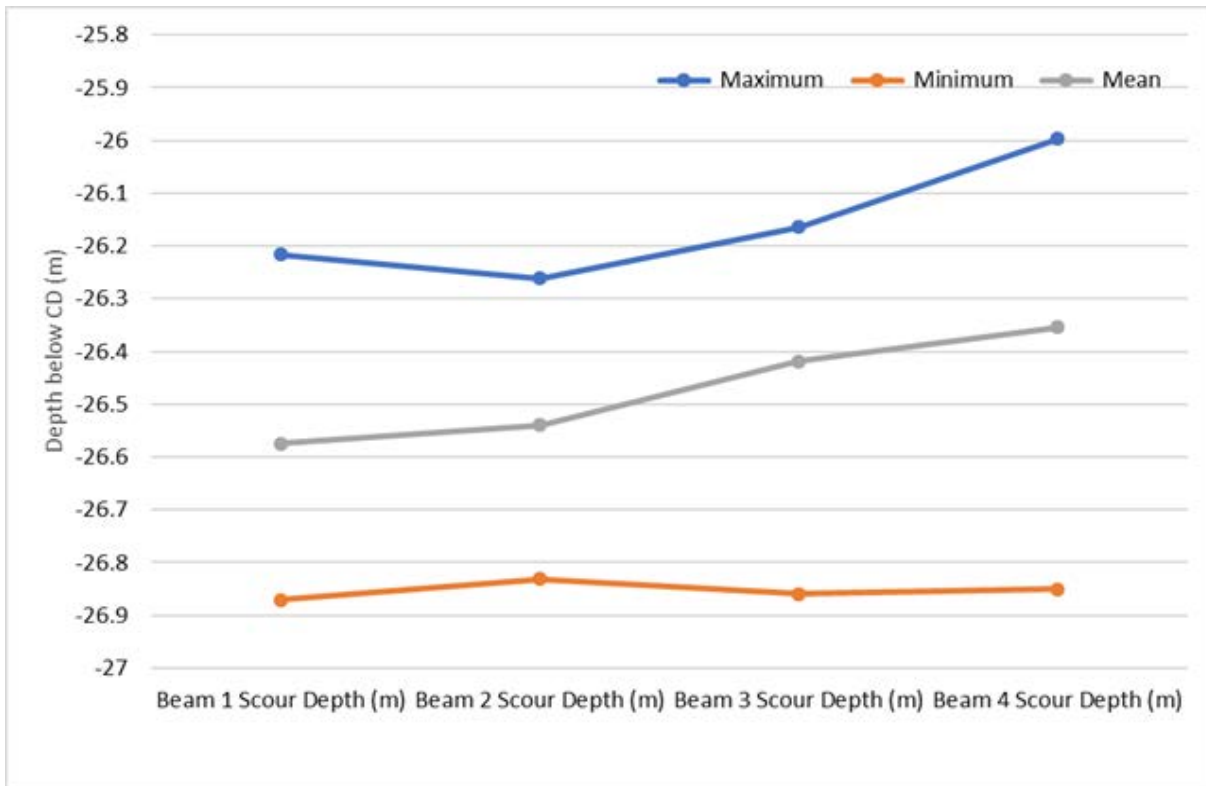

Figure 12. Summary mean scour profile.

Appendix C: May 2016 (Survey 1) Bathymetry Survey Technical Report

The May 2016 (Survey 1) Bathymetry Survey Technical Report was provided as Appendix E in the report entitled “*Field Observations during Wind Turbine Foundation Installation at the Block Island Wind Farm, Rhode Island*” (HDR 2018).

Appendix D: October 2016 (Survey 2) Bathymetry Survey Technical Report

The October 2016 (Survey 2) Bathymetry Survey Technical Report was provided as Appendix E in the report entitled “*Field Observations during Wind Turbine Foundation Installation at the Block Island Wind Farm, Rhode Island*” (HDR 2018).

Appendix E: May 2017 (Survey 3) Bathymetry Survey Technical Report

The May 2017 (Survey 3) Bathymetry Survey Technical Report was provided as Appendix E in the report entitled “*Field Observations during Wind Turbine Foundation Installation at the Block Island Wind Farm, Rhode Island*” (HDR 2018).

Appendix F: October 2017 (Survey 4) Bathymetry Survey Technical Report

FUGRO

**Seafloor Disturbance and Recovery Monitoring Program
Survey 5 September 2018
Block Island Wind Farm, USA**

Fugro Job No.: 02.81150001

Task Order No. 03, 0000023102

August 23, 2019

HDR Environmental, Operations and Construction, Inc.

The logo for HDR, consisting of the letters "HDR" in a large, bold, dark grey sans-serif font.

Document Number: 02.81150001-5

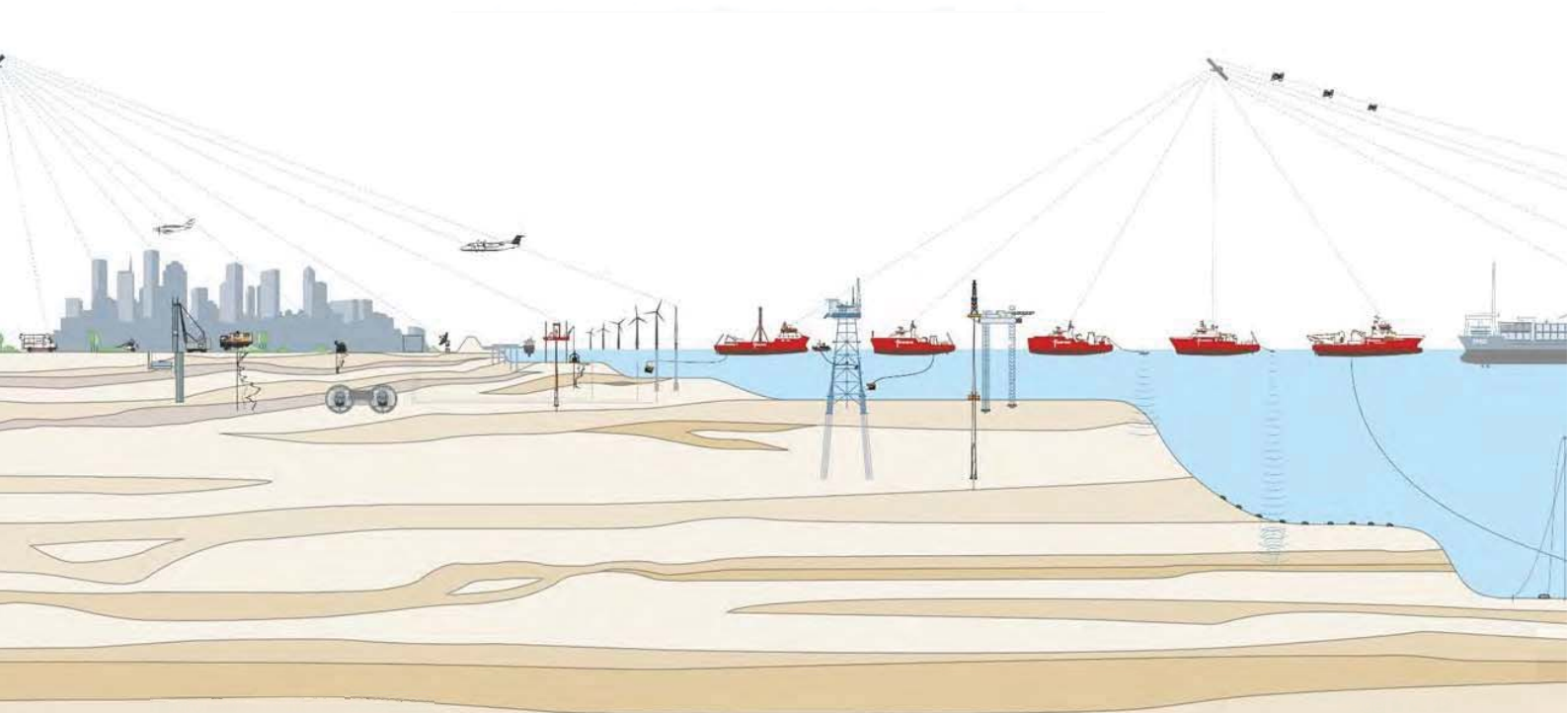



**Seafloor Disturbance and Recovery
Monitoring Program Survey 5
September 2018**
Block Island Wind Farm, USA

August 23, 2019

Fugro Job No.: 02.81150001
Task Order No.: 10, 0000023102

Prepared for: HDR
300 North Madison Street
Athens, Alabama 35611
USA



02	Revised Complete	WBC	KRS	KRS	August 23, 2019
01	Complete	TRW	WBC	KRS	January 15, 2019
Issue	Report Status	Prepared	Checked	Approved	Date

CONTENTS

1.	INTRODUCTION	1
1.1	Real-Time Opportunity for Development Environmental Observations (RODEO) Program	1
1.2	Seafloor Disturbance and Recovery Monitoring	1
1.3	Block Island Wind Farm	1
1.3.1	2015 Construction Season	2
1.3.2	2016 Construction Season	2
1.4	Purpose and Scope	2
1.4.1	Cable Trench Recovery Monitoring	3
1.5	Authorization	3
2.	DATA COLLECTION, PROCESSING, AND INTERPRETATION METHODS	4
2.1	Survey Overviews	4
2.2	Hydrographic Surveys	4
2.2.1	Data Variability and Repeatability	5
2.3	Data Quality	5
2.4	Multibeam Backscatter Data	6
3.	MULTI-TEMPORAL ANALYSIS OF SEAFLOOR CHANGE	7
3.1	Seafloor Disturbance Features	7
3.1.1	Wind Turbine Generator 1	8
3.1.2	Wind Turbine Generator 2	8
3.1.3	Wind Turbine Generator 3	8
3.1.4	Wind Turbine Generator 4	9
3.1.5	Wind Turbine Generator 5	9
3.2	Seafloor Disturbance Recovery	9
3.2.1	Wind Turbine Generator 1	11
3.2.2	Wind Turbine Generator 2	12
3.2.3	Wind Turbine Generator 3	13
3.2.4	Wind Turbine Generator 4	14
3.2.5	Wind Turbine Generator 5	14
3.2.6	Recovery from Seafloor Disturbance Elsewhere in the Work Area	14
3.2.7	Cable Trench Monitoring	15
3.2.8	Seafloor Recovery Rates	16
4.	SUMMARY	19
5.	REFERENCES	22

LIST OF TABLES

Table 1.1: Summary of Construction Activities and Surveys	2
Table 2.1: Comparison of Elevation Measurements	5
Table 3.1: Summary of Seafloor Recovery	10
Table 3.2: Area of Disturbance within 175 meters of Each Turbine	11
Table 3.3: Summary of Cable Trench Recovery	16
Table 3.4: Seafloor Recovery per Zone	18

LIST OF FIGURES

Study Area	1
Fugro September 2018 Bathymetry	2a
Interpreted Seafloor Disturbance Features	2b
Wind Turbine No. 1 Bathymetry & Seafloor Disturbances	3a, 3b, 3c, 3d
Wind Turbine No. 2 Bathymetry & Seafloor Disturbances	4a, 4b, 4c, 4d
Wind Turbine No. 3 Bathymetry & Seafloor Disturbances	5a, 5b, 5c, 5d
Wind Turbine No. 4 Bathymetry & Seafloor Disturbances	6a, 6b, 6c, 6d
Wind Turbine No. 5 Bathymetry & Seafloor Disturbances	7a, 7b, 7c, 7d
Wind Turbine Generators Bathymetry Comparison	8
Wind Turbine No. 1 Recovery Profile	9a
Wind Turbine No. 1 Recovery Profile (Concrete Mattresses)	9b
Wind Turbine No. 2 Recovery Profile	10a
Wind Turbine No. 2 Recovery Profile (Concrete Mattresses)	10b
Wind Turbine No. 3 Recovery Profile	11
Wind Turbine No. 4 Recovery Profile	12
Inter-Array Cable Comparison	13
Surficial Sediment Mobility Comparison	14
Interpreted Seabed Recovery Rates	15
Fugro MBES Backscatter	16

LIST OF CHARTS

Fugro Bathymetric Survey (September 2018)	1
Fugro Bathymetric Survey Interpreted Features (September 2018)	2
Seafloor Disturbance Feature Catalogue (Survey 4-October 2017)	3
Seafloor Disturbance Feature Catalogue (Survey 3-May 2017)	4
Seafloor Disturbance Feature Catalogue (Survey 2-October 2016)	5
Seafloor Disturbance Feature Catalogue (Survey 1-May 2016)	6
Export Cable/Block Island Transmission Cable Recovery	7
Fugro Bathymetric Survey Interpreted Features Per Survey	8
Fugro MBES Backscatter	9



APPENDICES

APPENDIX A: BATHYMETRIC SURVEY DATA ACQUISITION AND PROCESSING

Caris Swath Editor A-1
Caris Swath Subset Editor..... A-2
Vessel Offset Diagram for the R/V *Westerly* A-3

APPENDIX B: INSTALLATION VESSEL SPECIFICATIONS

L/B *Michael Eymard* Specifications B-1
L/B *Brave Tern* Specifications B-2

APPENDIX C: CATALOG OF SEAFLOOR DISTURBANCE FEATURES

Seafloor Disturbance Features (Construction Season 1 and 2)C-1

APPENDIX D: TYPICAL TURBINE AND PLATFROM CONSTRUCTION DRAWINGS



1. INTRODUCTION

1.1 Real-Time Opportunity for Development Environmental Observations (RODEO) Program

The United States (U.S.) Department of Interior's Bureau of Ocean Energy Management (BOEM) is responsible for managing the exploration and development of the nation's offshore energy resources. The BOEM conducts environmental reviews, including National Environmental Policy Act (NEPA) analyses, for each major stage (leasing, site assessment, construction, operations, and decommissioning) of proposed offshore energy development projects. Through these reviews and analyses, the BOEM evaluates potential environmental impacts from the proposed offshore activities on the human, coastal, and marine environments. The NEPA analysis is used to inform the decision-making process for whether and/or how to proceed with the approval of the offshore energy development.

To conduct the required analyses and effectively analyze the potential environmental impacts under NEPA, the BOEM requires data on impact-producing factors (stressors) and their effects on ecosystems and individual receptors. Development of offshore wind energy is new to the U.S.; therefore, data necessary for assessment of environmental impacts are not readily available. Thus, the BOEM has initiated the Real-Time Opportunity for Development Environmental Observations (RODEO) Program. The purpose of this program is to make direct, real-time measurements of the nature, intensity, and duration of potential stressors during the construction and/or initial operations of selected offshore wind facilities.

Data collected under the RODEO Program may be used as input to analyses or models that are employed to evaluate effects or impacts from future offshore activities. The first facility to be part of the RODEO Program monitoring is the Block Island Wind Farm (BIWF) Project, which is located off the coast of Rhode Island.

1.2 Seafloor Disturbance and Recovery Monitoring

The seafloor can be disturbed by various activities during the construction and operational phases of a wind farm development. During construction and/or maintenance, vessel anchoring activities and spud can penetrations may result in depressions in the seafloor. In addition, while a lift boat is positioned on site, scour can develop around the legs that penetrate the seafloor. Evidence of those impacts on the environment can disappear as sediment is reworked and transported due to natural processes after construction equipment is removed from the seafloor. The recovery rate from a seafloor disturbance primarily depends on sediment type, bottom current flow conditions (e.g. speed, duration, direction, etc.), and size of the disturbance feature.

This study utilizes repeated bathymetric surveys for use as a multi-temporal analysis tool to monitor for disturbance and recovery of the seafloor.

1.3 Block Island Wind Farm

Deepwater Wind (DW) recently constructed the BIWF, which is located approximately five kilometers (km) southeast of Block Island, Rhode Island. The BIWF is comprised of five wind turbine generators with a name-plate capacity of 30 megawatts (MW). Figure 1 presents the location of the BIWF and survey area. The BIWF was constructed during two construction seasons as described in the following sections.



1.3.1 2015 Construction Season

During 2015, DW installed foundations for the five wind turbine generators (WTGs). The lift boats used to install the WTG foundations were the L/B *Robert*, L/B *Lacie Eymard*, and the L/B *Michael Eymard*. The foundations installed are four-legged jackets that used 1524-millimeter (60-inch) diameter piles. Appendix D provides typical construction drawings of the foundations. Construction activities occurred from late spring 2015 through December 2015.

1.3.2 2016 Construction Season

Construction activities during the 2016 season included installing the towers, nacelles, blades, inter-array cable, export cable, and finishing works on the foundations. Towers, nacelles, and blades were installed using Fred Oslen’s L/B *Brave Tern*. Foundation works were performed during May and June 2016. Cabling was installed during June and July using a jet trenching technique. The L/B *Brave Tern* installed the towers, blades and nacelles during July and August. Final cable pulls into the turbines, concrete mats and ancillary works were performed in September. Concrete mattresses were placed where the cable installation did not reach the desired burial depths. In areas near the WTGs, the cable was intentionally left unburied until the final cable pull into the turbine was performed. After the pull, concrete mats were placed on the short section of exposed cable on the seafloor near each turbine. Appendix D provides typical construction drawings that depict the various cable and turbine installation details and methods.

1.4 Purpose and Scope

The Seafloor Disturbance and Recovery Monitoring Study utilized periodic bathymetric surveys to identify seafloor disturbance features and monitor seafloor recovery from the disturbances. The survey extent encompassed the area denoted by DW as the “Work Area.” The Work Area was the primary area where construction vessels were positioned during construction. Table 1.1 provides a summary of the various construction activities and bathymetric surveys conducted as part of the monitoring program.

Table 1.1: Summary of Construction Activities and Surveys

Time	Activity
Construction Season 1 Late Spring through December 2015	Installation of Jacket Foundations
May 11 and 12, 2016	Survey 1 (Construction Season 1 Baseline Survey)
Construction Season 2 May through September 2016	<ul style="list-style-type: none"> ▪ Installation of tower, nacelles, and blades ▪ Installation of inter-array and export cables <ul style="list-style-type: none"> ▪ Ancillary foundation works
October 2 to 5, 2016	Survey 2 (Construction Season 2 Baseline Survey)
May 18 and 19, 2017	Survey 3
October 2 and 3, 2017	Survey 4
September 29 and 30, 2018	Survey 5 (Current Report)

Fugro (2016, 2017a, 2017b, and 2017c)

This report presents the findings of the fifth bathymetric survey conducted by Fugro at the BIWF during September 29 and 30, 2018. The multibeam data from previous bathymetry surveys of the area (conducted by Fugro on May 11 and 12, 2016, October 2 to 5, 2016, May 18 and 19, 2017, and October

2 and 3, 2017) were compared to the September 2018 data to evaluate seafloor recovery from disturbances created during the 2015 and 2016 Construction Seasons.

1.4.1 Cable Trench Recovery Monitoring

Installation of cables (June-July 2016) using jet-trenching techniques utilize high-pressure water discharged from the jet-trencher to fluidize the sediments, thus excavating a trench that the cable falls into and is subsequently buried by the fluidized sediments suspended momentarily in the water column. After laying the cable, a trench scar (slight topographic depression created since not all of the fluidized sediments deposit back in the trench footprint) is usually visible for some time after installation. In most cases, reworking of the seafloor sediments buries the trench and the trench is no longer visible. The length of time it takes for this seafloor recovery to occur depends largely upon seafloor sediment type and bottom current characteristics (e.g. speed, duration, and direction).

Jet-trenching also causes the fluidized sediments that redeposit in the trench to generally be in a looser state than the undisturbed neighboring sediments. The looser, back-filled sediments may be more easily transported by bottom-currents and result in erosion of the trench backfill materials (Fugro, 2012).

The primary objective of the seafloor disturbance monitoring program is to monitor in the wind turbine construction area (the Work Area). However, during some of the surveys we took advantage of opportunities to collect data along the cable route to support assessments of cable trench recovery when time allowed. This report presents results from those partial cable route surveys.

1.5 Authorization

Authorization for this work was provided by HDR Master Service Agreement No. MSA2015-1165, under task order TO 007, 1000300000862 and Modification No.1, between HDR and Fugro, dated August 2, 2017 and January 29, 2018, respectively.



2. DATA COLLECTION, PROCESSING, AND INTERPRETATION METHODS

2.1 Survey Overviews

During September 29 and 30, 2018, Fugro conducted the fifth hydrographic survey (Survey 5) of the Work Area surrounding the five Block Island wind turbines. Figures 1 and 2a and Chart 1 show the extent of the hydrographic survey. Survey 5 encompassed the same area that was surveyed during Survey 1 on May 11 and 12, 2016, Survey 2 on October 2 to 5, 2016, Survey 3 on May 18 and 19, 2017, and Survey 4 on October 2 and 3, 2018. All hydrographic surveys were conducted using a pole-mounted multibeam echosounder aboard a small research vessel. A detailed description of the survey vessel, instrument offsets, calibration tests, data acquisition and processing methods are provided in Appendix A of this report. Table 1.1 provides a summary of the surveys and phases of construction.

2.2 Hydrographic Surveys

The Construction Season 1 (2015) baseline survey was conducted in May 2016 and the results from that survey were provided in the Survey 1 report. Survey 1 was conducted using the chartered vessel R/V *Jamie Hanna*. The R/V *Jamie Hanna* is a 55-foot long purpose-built survey vessel. Surveys 2 through 5 were conducted using the chartered vessel R/V *Westerly*. The R/V *Westerly* is a 50-foot long purpose-built, catamaran style survey vessel (Appendix A, Figure A-3). Surveys 2 through 5 were conducted in October 2016, May 2017, October 2017, and September 2018 respectively. Survey 2 represents the Construction Season 2 baseline survey. This report describes the data acquisition, processing and evaluation of the data from Survey 5.

The survey vessels were equipped with a pole-mount for the echosounder transducers. All the hydrographic surveys were conducted at speeds ranging from four to seven knots. Survey 5 was conducted using a R2Sonic Sonic 2024 high-resolution multibeam echosounder (designed to operate in water depths ranging from 0.5 meters to 200 meters). The nominal vertical resolution of post-processed data is likely approximately 10 centimeters (depending on sea state, tidal error, seafloor gradient, sounding position along track, and other factors).

Multibeam data from the surveys were collected in WinFrog software and were visually monitored during the survey for quality assurance. The WinFrog *.s7k files were then brought into CARIS for bathymetric processing. Subsequently, corrections for vessel offsets, patch test calibration, and static draft measurements were input into the software. Sound Velocity Profiles (SVPs) were then used to correct the bathymetric data for sound refraction or ray bending.

After each line was examined and cleaned in CARIS' Swath Editor, the tide corrections were loaded and the lines were merged. The merged dataset was then examined to identify tidal discrepancies, sound velocity errors, motion errors, and data gaps. Once all processing was completed, a digital terrain model (DTM) was generated with CARIS at a 0.5 meter bin size. The ASCII XYZ grid file of easting, northing, and depth values in meters was then output from CARIS for interpretation.

All data from all the surveys were projected in metric measurement (meters) with the Universal Transverse Mercator (UTM) Zone 19 North coordinate system, using the World Geographic System of 1984 (WGS84) geodetic datum. The real-time navigation and position data were used as the geodetic control, receiving differential global navigation satellite system (GNSS) corrections via a G2 subscription to Fugro's OmniStar service. All real-time positioning data were converted to WGS84 (g1150) using an



Applanix POS MV positioning system. This real-time positioning was used to process the multibeam survey lines. Horizontal positioning error at the vessel's common reference point (CRP) is estimated to be less than one meter (during optimal conditions).

Bathymetric data from all the surveys were reduced to mean lower low water (MLLW) based on the National Oceanic and Atmospheric Administration (NOAA) VDatum model (<http://vdatum.noaa.gov>). This model provides separation values from the GNSS ellipsoid down to the chart datum of MLLW for the survey area. These values were then applied to the bathymetry using the CARIS HIPS Compute GPS Tide routine.

2.2.1 Data Variability and Repeatability

Samples of water depth values from a selected area within the BIWF that was interpreted to undergo no significant seafloor change between the four surveys were used to establish a baseline degree of variability between the four surveys. The elevation difference between the surveys was obtained by extracting data within the analysis area and then subtracting values on a bin node-by-node basis. The results are summarized in Table 2.1.

Table 2.1: Comparison of Elevation Measurements

Statistic	May 2016 / Sep. 2018 Comparison	Oct. 2016 / Sep. 2018 Comparison	May 2016 / Sep. 2018 Comparison	Oct. 2017 / Sep. 2018 Comparison
Analysis area size (square meters)	120,610	120,610	120,610	120,610
Minimum Difference (meters)	-0.24	-0.16	-0.22	-0.18
Maximum Difference (meters)	0.23	0.21	0.22	0.20
Mean Difference (meters)	0.03	0.03	0	0.03
Standard Deviation (meters)	±0.05	±0.05	±0.05	±0.05

An average systematic bias of 0.05 meters was observed in the sample set that can likely be attributed to tidal error, subtle boat draft discrepancies, and normal limitations associated with multibeam head calibration. Significant systematic bias can also be attributed to survey line direction. In addition, some components of random variability are evident in the sample set and are likely due to sea state, horizontal positioning uncertainty, and other factors. If the assumption of no bathymetric change for the benchmark area is valid, the standard deviation (±0.05 meters) reflects the uncertainty of vertical difference calculated for the five surveys and can be used to help identify areas likely to be of significant seafloor change across the BIWF study area. Seafloor difference values greater than two standard deviations (±0.1 meters) are interpreted to represent bathymetric change that is likely (at the 95 percent confidence interval) to be significant with respect to the data limitations of the surveys.

2.3 Data Quality

Sea states during the May 2016 survey were relatively calm, resulting in fair raw data quality. Minimal data processing was required to generate bathymetric deliverables that were relatively free of motion artifacts and other surface noise. Sea states during the October 2016 were fair to marginal. Quality of the raw data collected during the October 2016 survey was reported to be affected by the marginal sea states and motion artifacts were noted on the outer portions of the bathymetric swath. Post-acquisition data processing resulted in final deliverables of good quality; however, some motion related artifacts are still observable in the final DTM but the data are deemed adequate for meeting the study's objectives. Data quality for the raw data collected for the May 2017 survey was reported to be affected by some motion in the moonpool at the time of the survey; however, the overall data quality was good and post-

acquisition data processing resulted in final deliverables of good quality. Similarly, the data quality collected for the October 2017 survey was degraded slightly by vessel motion at the time of the survey, but the overall data quality was good. Sea states during the September 2018 survey were fair to marginal. Some subtle linear motion artifacts are present in the DTM and tidal offsets of approximately 5 to 10 cm between swaths are present, but the data were deemed as adequate for meeting the study's objectives.

2.4 Multibeam Backscatter Data

Multibeam backscatter data are used to evaluate seafloor conditions and habitat type. Backscatter data are related to sediment grain size and seafloor roughness and provide qualitative and quantitative information on the composition of the seafloor.

Multibeam backscatter data were collected using the R2Sonic 2024 Multibeam Echosounder. Multibeam backscatter data have been processed from Surveys 3, 4, and 5 and have been used to support the interpretation of sediment types, bedforms, and changes in the seafloor conditions. Limited grain size data (e.g. grab samples collected during RODEO's Benthic Monitoring Program near WTGs 1, 3, and 5) and limited seafloor sediment type information from Deepwater Wind reports were available and incorporated in the evaluation of the backscatter data. Figure 16 and Chart 9 present backscatter data collected during Survey 5.



3. MULTI-TEMPORAL ANALYSIS OF SEAFLOOR CHANGE

This study is performing a multi-temporal analysis to identify seafloor disturbances related to wind farm construction activities and monitor the recovery from those seafloor disturbances. High-resolution bathymetric data acquired during periodic surveys are being analyzed to evaluate the seafloor changes.

The BIWF was constructed during two separate construction seasons (Construction Season 1 in 2015 and Construction Season 2 in 2016, respectively). The “Work Area,” as designated by DW, was the primary area where construction vessels were positioned during construction. The bathymetric surveys encompass the Work Area delineated as the Survey Area displayed in Figure 1. This report describes the results from the fifth survey which evaluates the recovery from disturbances created during Construction Season 1 (2015) and Construction Season 2 (2016).

3.1 Seafloor Disturbance Features

Multibeam bathymetry data acquired during the survey were processed, rendered and evaluated to identify seafloor disturbance features inferred to be related to construction activities. Processed multibeam data were interpolated to create a DTM with a 0.5-meter bin size as described in Section 2.2. Sun-illuminated, hillshaded-relief renderings of the seafloor DTM were also created to enhance seafloor features and aid in visually identifying seafloor disturbances. Interpreted seafloor disturbance features are classified based on the following:

- Spud: Circular or rectangular depressions arranged in a pattern that match one of the lift boats and are generally located near a WTG. Likely created when a lift boat was on position during installation of the turbine.
- Circular Depression: Circular depression not associated with a geometric pattern that would have been created when a lift boat was on position and had all 3 or 4 legs deployed. Circular depression was generally located away from WTG position and may be related to a spud depression or anchor drop.
- Drag Mark: Elongated or linear disturbance feature likely created from the dragging of a spud leg or anchor.
- Scour: Scour feature that formed around the leg of the jacket foundation or around the concrete mat cable protection.

Figure 2b and Chart 2 presents the locations and classifications of the seafloor disturbance features from Construction Season 1 (2015) and Construction Season 2 (2016) that were still visible in Survey 5 (September 2018). Figures 3 through 7 present a series of maps focused on each turbine area. The information presented on each respective series includes:

- “a” series (Figures 3a, 4a, ...) - Bathymetric contours,
- “b” series (Figures 3b, 4b, ...) - Interpreted disturbance features symbolized based on type of feature, and
- “c” series (Figures 3c, 4c, ...) - Interpreted disturbance features symbolized based on the associated Construction Season. Figures also include the baseline footprint of each feature.
- “d” series (Figures 4d, 5d, ...) – Bathymetric difference between Surveys 2 and 4 to illustrate magnitude of seafloor elevation changes.



This report presents the results from the fifth survey. Surveys 1 and 2 represent the baseline surveys for Construction Seasons 1 and 2, respectively. Table 3.1 provides a summary of the seafloor disturbances that were interpreted from the respective baseline surveys.

Table 3.2 provides a summary of the seafloor disturbance associated with installation of each turbine. Seafloor disturbance related to installation of the wind turbine components (e.g. foundations, nacelles, blades, etc.) appears to be confined to the area within 175 meters of each turbine. Table 3.2 categorizes features into:

- Temporary Disturbance Feature: Disturbance caused by construction equipment activities that temporarily occurred on site (e.g. jacking-up of a vessel that left the site after a few hours or days)
- Long-term Disturbance Feature: Disturbance (scour) related to a structure being installed at the site until the project is decommissioned. Scour features related to turbine foundations or concrete mattresses are examples of long-term features anticipated to be present until the structure is removed.
- Cable Trench Feature: Inter-array cable trench scar and concrete mattresses created during Construction Season 2.

3.1.1 Wind Turbine Generator 1

Wind Turbine Generator 1 (WTG 1) is located in the northeastern-most section of the study area and is associated with several well-resolved seafloor disturbances. The surficial sediment around WTG 1 is coarse- to medium-grained sand with fine gravel and contains patches of rippled sand and gravel. Figures 3a, 3b, 3c, and Chart 2 present the local bathymetry and interpreted seafloor disturbances that have occurred around WTG 1. Seafloor disturbances that were created during Construction Season 1 and those that were created during Construction Season 2 are differentiated in Figure 3c. All disturbance features extents are outlined from Surveys 1 to 5 (if possible) to aid in discerning if changes in their size or position has occurred (Figure 3c).

3.1.2 Wind Turbine Generator 2

Wind Turbine Generator 2 (WTG 2) is located in the northeastern section of the study area and is associated with several seafloor disturbances. The surficial sediment surrounding WTG 2 is similar to WTG 1 and is composed of mixed coarse- to medium-grained sand with fine gravel and contains alternating patches of rippled sand and gravel in the vicinity. Figures 4a, 4b, 4c, and Chart 2 present the local bathymetry and interpreted seafloor disturbances that have occurred around WTG 2. Seafloor disturbances that were created during Construction Season 1 and those that were created during Construction Season 2 are differentiated in Figure 4c. All disturbance features extents are outlined from Surveys 1 to 5 (if possible) to aid in discerning if changes in their size or position has occurred (Figure 4c).

3.1.3 Wind Turbine Generator 3

Wind Turbine Generator 3 (WTG 3) is located in the central section of the study area, in a slightly deeper channelized area of the seafloor with wave ripples becoming more dominant. The surficial sediment surrounding WTG 3 is predominantly medium-grained sand with a minor component of fine gravel. Figures 5a, 5b, 5c, and Chart 2 display the local bathymetry and the interpreted seafloor disturbances that have occurred around WTG 3. Seafloor disturbances that were created during Construction Season 1 and those that were created during Construction Season 2 are differentiated in Figure 5c. All

disturbance features extents are outlined from Surveys 1 to 5 (if possible) to aid in discerning if changes in their size or position has occurred (Figure 5c).

3.1.4 Wind Turbine Generator 4

Wind Turbine Generator 4 (WTG 4) is located in the southwestern section of the study area. The surficial sediment surround WTG 4 is a coarse sand and contains alternating patches (ridges/furrows) of sand and gravel, with wave ripples of up to 20 centimeters being apparent. Figures 6a, 6b, 6c, and Chart 2 display the local bathymetry and the interpreted seafloor disturbances that have occurred around WTG 4. Seafloor disturbances that were created during Construction Season 1 and those that were created during Construction Season 2 are differentiated in Figure 6c. All disturbance features extents are outlined from Surveys 1 to 5 (if possible) to aid in discerning if changes in their size or position has occurred (Figure 6c).

3.1.5 Wind Turbine Generator 5

Wind Turbine Generator 5 (WTG 5) is located in the southwestern-most section of the study area. The surficial sediment surrounding WTG 5 is predominantly medium to coarse sand. Figures 7a, 7b, 7c, and Chart 2 display the local bathymetry and the interpreted seafloor disturbances that have occurred around WTG 5. Seafloor disturbances that were created during Construction Season 1 and those that were created during Construction Season 2 are differentiated in Figure 7c. All disturbance features extents are outlined from Surveys 1 to 5 (if possible) to aid in discerning if changes in their size or position has occurred (Figure 7c).

3.2 Seafloor Disturbance Recovery

The rate of recovery from the initial disturbance back to a natural seafloor is dependent on a variety of factors. Some of the main influences on seafloor recovery are bottom current speeds, surficial sediment type, and the influence of large storm events (which can drastically alter the normal flow conditions at a site). Seafloor features identified in the May 11 and 12, 2016 bathymetric survey, in the October 2 through 5, 2016 survey represent baseline conditions from Construction Season 1 (2015) and Construction Season 2 (2016), respectively.

The fifth survey data were compared to the first, second, third, and fourth survey data to evaluate what changes (e.g. recovery), if any, had occurred to seafloor disturbance features created during the two construction seasons. Figures 3c, 4c, 5c, 6c, and 7c symbolize the features based on the construction season they were created. Also, the baseline footprints are shown as light gray (Construction Season 1) and dark gray (Construction Season 2) outlines on the Survey 5 renderings in Figures 3c, 4c, 5c, 6c, and 7c to compare how those features changed between surveys. Figure 8 displays a time series from Survey 1 (May 2016) to Survey 5 (September 2018) for each WTG location to depict seafloor changes observed during the surveys. Each WTG location is discussed in further detail below in Section 3.2 of this report.

Construction Season 1 and 2 baseline surveys identified 139 and 101 disturbance features (160 and 103 if scour features are included), respectively (Charts 5 and 6). Scour features created by the installed structures are not included because they are likely to remain present as long as the structure is present. Survey 5 data indicate that 90 and 87 of Construction Seasons 1 and 2 features, respectively have completely healed. Observations of Survey 5 data suggest all construction disturbance features appear



Table 3.1: Summary of Seafloor Recovery

Interpreted Features	Construction Season Baseline Disturbance						Construction Season 1 (2015) Disturbances												Construction Season 2 (2016) Disturbances									2015 and 2016 Disturbances Recovery	
	Construction Season 1 (2015) Features		Construction Season 2 (2016) Features		Construction Seasons 1 and 2 Total		Recovery Since Baseline at Time of Survey 2 (Oct. 2016)			Recovery Since Baseline at Time of Survey 3 (May 2017)			Recovery Since Baseline at Time of Survey 4 (Oct. 2017)			Recovery Since Baseline at Time of Survey 5 (Sep. 2018)			Recovery Since Baseline at Time of Survey 3 (May 2017)			Recovery Since Baseline at Time of Survey 4 (Oct. 2017)			Recovery Since Baseline at Time of Survey 5 (Sep. 2018)				
	Number of Features	Area (m ²)	Number of Features	Area (m ²)	Number of Features	Area (m ²)	Partially Healed Features	Healed Features	Healed Area (m ²)	Partially Healed Features	Healed Features	Healed Area (m ²)	Partially Healed Features	Healed Features	Healed Area (m ²)	Partially Healed Features	Healed Features	Healed Area (m ²)	Partially Healed Features	Healed Features	Healed Area (m ²)	Partially Healed Features	Healed Features	Healed Area (m ²)	Partially Healed Features	Healed Features	Healed Area (m ²)		
Spud	26	1,102	37	4,152	63	5,254	19	0	0 (0%)	8	18	663 (60%)	3	20	710 (64%)	4	20	710 (64%)	25	12	830 (20%)	12	17	1,790 (43%)	11	26	2,269 (55%)	2,979	57%
Circular Depressions	69	2,803	51	1,595	120	4,398	0	3	58 (2%)	31	38	1,454 (52%)	12	44	1,634 (58%)	21	48	1,752 (63%)	8	43	1,298 (81%)	7	46	1,388 (87%)	5	47	1,407 (88%)	3,159	72%
Drag Marks	44	6,414	13	1,129	57	7,543	1	12	1,300 (20%)	25	19	2,077 (32%)	10	20	2,540 (40%)	22	22	2,660 (41%)	1	12	1,061 (94%)	0	13	1,129 (100%)	0	13	1,129 (100%)	3,789	50%
Total*	139 ^b	10,319	101 ^b	6,876	240	17,195	20	15	1,358 (13%)	64	75	4,194 (41%)	25	84	4,884 (47%)	47	90	5,122 (50%)	34	67	3,189 (46%)	19	76	4,307 (63%)	16	86	4,805 (70%)	9,927	58%

Notes:

^a Features were classified as partially healed if the disturbance feature had lessened in size or depth but still remained discernible. A feature was classified as completely healed if the feature was no longer discernible in the bathymetric data.

^b Twenty-one scour features were identified from the Construction Season 1 disturbances which results in a total of 160 disturbance features from Season 1. Two new scour features were identified from Construction Season 2 disturbances which results in a total of 103 disturbance features from Season 2. Scour features formed as a result of installing wind turbine foundations or concrete mattresses. The scour features are not included in the recovery statistics since they are likely to be present as long as the structures (e.g. foundations and concrete mattresses) are present.

^c Inter-array and export cable trench scars and recovery are not included in this table. Refer to Section 3.2.7 and Table 3.3 for assessment of cable trenching disturbance and recovery.

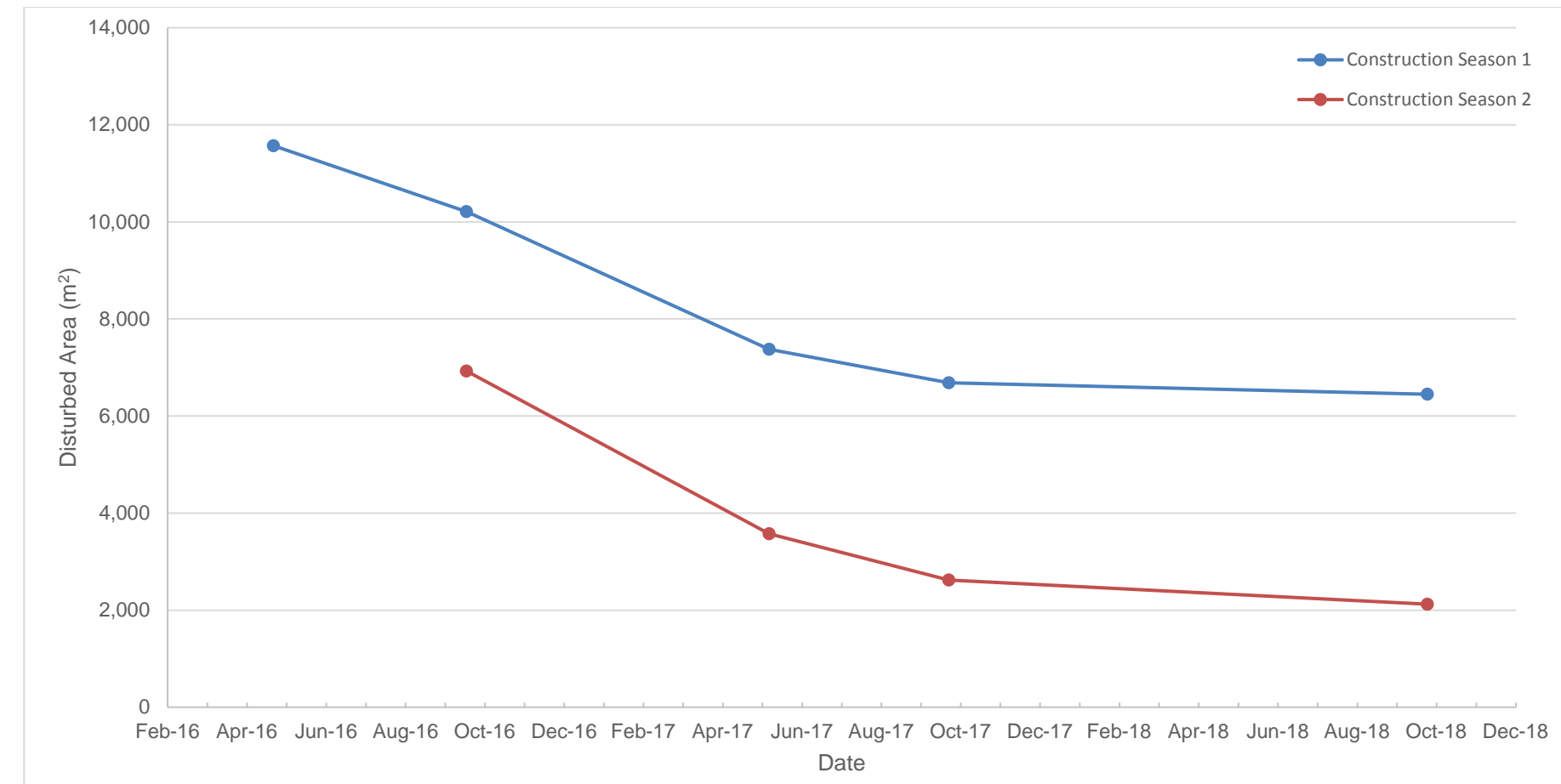

Inset graph (left) presents a summary of the disturbed seafloor area interpreted from each survey.



Table 3.2: Area of Disturbance within 175 meters of Each Turbine

Turbine	CS1 Temporary Features ^a	CS2 Temporary Features ^a	CS1 and CS2 Temporary Features ^a	Long-Term Features (Foundations) ^a	Long-Term Features (Concrete Mats on Cables) ^a	Cable Trench Features ^a	All Features Combined Season 1 and 2 ^a
WTG 1	838 m ² 0.9%	2,261 m ² 2.4%	3,099 m ² 3.2%	308 m ² 0.3%	1,074 m ² 1.1%	1,266 m ² 1.3%	5,747 m ² 6.0%
WTG 2	180 m ² 0.2%	1,001 m ² 1.0%	1,181 m ² 1.2%	268 m ² 0.3%	840 m ² 0.9%	1,566 m ² 1.6%	3,855 m ² 4.0%
WTG 3	100 m ² 0.1%	1,003 m ² 1.0%	1,103 m ² 1.1%	264 m ² 0.3%	840 m ² 0.9%	1,692 m ² 1.8%	3,899 m ² 4.1%
WTG 4	1,100 m ² 1.1%	1,201 m ² 1.2%	2,301 m ² 2.4%	290 m ² 0.3%	636 m ² 0.7%	1,716 m ² 1.8%	4,943 m ² 5.1%
WTG 5	508 m ² 0.5% ^b	508 m ² 0.5%	1,016 m ² 1.1% ^b	109 m ² 0.1%	426 m ² 0.4%	1,038 m ² 1.1% ^c	2,589 m ² 2.7% ^b

Notes;

^a Disturbance is presented in area and percentage of area within 175m of the wind turbine. This is assumed to be the area where installation vessels would be positioned during construction of a wind turbine.

^b Season 1 seafloor disturbance features were not discernable for WTG 5. Seafloor disturbance (e.g. leg penetration) was likely limited due to dense sandy sediments at that location and reworking of sediments likely healed seabed scars by the time the survey was conducted. We have assumed the seafloor disturbance during Season 1 to be equal to Season 2 for estimating purposes. This is likely a conservative assumption.

^c WTG 5 has only one cable connection whereas the other turbine locations have two.

^d Footprint of foundation piles are included in disturbance area

to be undergoing either infilling and/or decrease in size albeit at varying rates. Figures 3c, 4c, 5c, 6c, and 7c and Chart 8 present the baseline footprints of the disturbance features (Construction Season 1 outlined in light gray and Construction Season 2 outlined in dark gray) and their extents as observed in Survey 3 (outlined in black), Survey 4 (outlined in red), and Survey 5 (outlined in orange).

Table C-1 (Appendix C) lists the features that were originally catalogued from Survey 1 and 2 and the observed relative changes (e.g. some change, mostly healed, etc.) that were interpreted to have occurred between May 2017 and September 2018. Table 3.1 presents a summary of the observed recovery from Construction Season 1 and 2 disturbances

3.2.1 Wind Turbine Generator 1

Construction Season 1 Features: Thirteen of the 21 Construction Season 1 features (F77, F95, F98-101, and F103-109) appear to have completely healed and are not discernable in the September 2018 (Survey 5) survey data (Figure 3c and Table C-1). Seven seafloor disturbance features (F82, F92, F96, and F122-125) seem to have diminished in depth associated with sediment infilling (up to 4 centimeters) though F96 appears to be conjoining F160 from Season 2 or F160 may appear larger than previously defined. The remaining feature, F97, of the 21 seafloor disturbances features created during Construction Season 1 displayed no significant change except for areal coverage in the Survey 5 (September 2018) bathymetric data.



Construction Season 2 Features: Forty of the 48 Construction Season 2 features (F198-200, F202-208, F218-220, F222-235, F238-243, F254-256, and F260-261) appear to have completely healed and are no longer discernable in the September 2018 (Survey 5) survey data (Figure 3c and Table C-1). Five seafloor disturbance features (F160-163 and F221) appear to have experienced sediment infilling. The most prominent of these features which remain visible, are the four spud depressions associated with the L/B *Brave Tern* (F160-163). Although the area of these features has approximately remained the same (approximately 150 square meters), they have all undergone infilling ranging from 0.1 to 0.2 meters (Figures 3b and 3c, Figure 9a, and Table C-1). Figure 9a presents profiles through the large spud depressions and the monitoring surveys reveal that they have been progressively infilling at rates of approximately 3 to 10cm per year. Three (F201, F217, and F236) of the 48 seafloor disturbance features created during Construction Season 2 do not appear to have undergone any significant change in the Survey 5 (September 2018) bathymetric data.

Post-Construction Features: Small erosional (scour) features (F263 through F268) have formed adjacent to the concrete mattresses placed on the inter-array cable near the turbines (Figure 3c). The extent of scour remains unchanged between Surveys 4 and 5.

Figure 9b presents profiles across various segments of the mattresses. The scour features extend approximately 1 to 3 meters from the mattresses and are approximately 10 to 25 cm deep. The scour is more prominent on the northern side of the concrete mattresses oriented perpendicular to the principle tidal current flow direction. The principle tidal flow axis is aligned in the NNW-SSE direction. Cable segment in Profile B is nearly aligned with the principle tidal axis and shows the least amount of scour. Cable segments shown in Profiles A, C, and D are oriented perpendicular to the principle tidal axis. Scour is most prevalent on the northern side of the cable/concrete mattresses which indicates the dominant tidal current flow at this location is likely to the NNW (flood tidal current direction).

Scour around the turbine legs appears to be very small to negligible based on the multibeam data. Small depressions up to approximately 5 to 20cm deep have been interpreted in previous monitoring surveys. In Survey 5, scour appears to be less than approximately 10cm at the legs.

3.2.2 Wind Turbine Generator 2

Construction Season 1 Features: Five of the 10 Construction Season 1 features (F102, F112 and F114-F116) appear to have completely healed and are no longer discernable in the September 2018 (Survey 5) survey data (Figure 4c and Table C-1). The remaining five features (F110-F111, F113, and F126-F127) associated with Construction Season 1 experienced little to no change.

Construction Season 2 Features: Twelve of the 16 Construction Season 2 features (F165, F185-190, F209-212, and F214) appear to have completely healed and are no longer discernable in the September 2018 (Survey 5) survey data (Figure 4c and Table C-1). Four seafloor disturbance features (F164, F166-167 and F213) seem to have experienced some degree of change associated with sediment infilling. The most notable of these features which underwent change between Surveys 4 and 5 are the spud depressions associated with the L/B *Brave Tern* (F164, F166-167). Figure 10a presents seafloor elevation profiles through the L/B *Brave Tern* spud depressions. The spud depressions appear to have infilled by 5 to 10cm since Survey 4. When they spud depression were first surveyed (Survey 2) they

were between 40cm and 80cm deep and at the time of Survey 5 they had infilled between approximately 50 to 80 percent complete.

Post-Construction Features: Small erosional (scour) features (F261 through F274) have formed adjacent to the concrete mattresses placed on the inter-array cable near the turbine (Figure 4c). The extent of scour remains largely unchanged between Surveys 4 and 5.

Figure 10b presents profiles across various segments of the mattresses. The scour features extend approximately 1 to 2 meters from the mattresses and are approximately 5 to 20 cm deep. Scour is more prominent on the northern side of the concrete mattresses oriented perpendicular to the principle tidal current flow direction. The principle tidal flow axis is aligned in the NNW-SSE direction. Cable segment in Profile B is nearly aligned with the principle tidal axis and shows the least amount of scour. Cable segments shown in Profiles A and C are oriented perpendicular to the principle tidal axis. Scour is most prevalent on the northern side of the cable/concrete mattresses which indicates the dominant tidal current flow at this location is likely to the NNW (flood tidal current direction).

Scour around the turbine legs appears to be very small based on the multibeam data. Small depressions up to approximately 5 to 20cm deep have been interpreted in previous monitoring surveys. In Survey 5, scour appears to be less than approximately 10 to 15cm at the legs.

3.2.3 Wind Turbine Generator 3

Construction Season 1 Features: Four of the 8 Construction Season 1 features (F80, F93, and F141-142) are completely healed and are not discernable in the September 2018 (Survey 5) survey data (Figure 5c and Table C-1). F128 appears to have undergone some change related to infilling in Survey 5. The remaining three disturbance features (F89, F94, and F129) which remained visible in the September 2018 survey data (Survey 5) displayed no significant change.

Construction Season 2 Features: The four spud depressions (Features F168-171) that were identified from the Construction Season 2 baseline survey (Survey 2—Oct. 2016) and associated with the L/B *Brave Tern* all appear to be completely healed in the September 2018 (Survey 5) survey data (Figures 5b, 5c, Figure 11, and Table C-1). Survey 2, the first survey that recorded the depressions, indicated they were between 70 and 110cm deep at one point. They infilled significantly (80 to 85%) between Surveys 2 and 3 (Figures 8 and 11).

Post-Construction Features: Little to no erosional (scour) features have formed adjacent to the concrete mattresses placed on the inter-array cable near the turbine. Scour around the turbine legs appears to be very small based on the multibeam data. Small depressions up to approximately 5 to 25cm deep have been interpreted in previous monitoring surveys. In Survey 5, scour appears to be less than approximately 10 to 15cm at the legs. As part of the RODEO program, scour monitors were installed on the northeast and southeast corner legs (Fugro, 2018). The scour monitors continuously recorded seabed elevation changes for a period of 14 months during 2016 and 2017 (Fugro, 2018). The scour monitors recorded seabed level changes of up to approximately:

- 0.2m over tidal cycles and
- 0.6m over one month periods.



3.2.4 Wind Turbine Generator 4

Construction Season 1 Features: Five of the nine Construction Season 1 features (F78, F117-119, and F121) appear to have completely healed and are not discernable in the September 2018 (Survey 5) survey data (Figures 6b, 6c and Table C-1). Seafloor disturbance features F130-F131 associated with Construction Season 1 experienced some change related to sediment infilling and seafloor disturbance features F81 and F120 experienced little to no change.

Construction Season 2 Features: Eight of the 10 Construction Season 2 features (F174-175 and F246-251) appear to have completely healed and are not discernable in the September 2018 (Survey 5) survey data (Figure 6c and Table C-1). The remaining two features (F172-173) are two of the four spud depressions attributed to the L/B *Brave Tern* (F172-175) (Figures 6b and 12). Two of these spud depressions (F174 and 175) have completely healed, while the two northeastern spud depressions (F172-173) appear to have experienced very little infilling since Survey 4 (Figure 6b and Figure 12). The differing infill rates of the L/B *Brave Tern* leg depressions is remarkable. The two southwestern leg depressions that have completely healed are located in a ripple field that is actively changed between surveys. The ripples changed in orientation and extent and indicates higher rates of sediment reworking than where the two northeastern depressions are located. The spud can depressions were observed to be up approximately 60cm deep during Survey 2. The northeastern spud depressions are approximately 40 to 50 percent infilled at the time of Survey 5 (Figure 12).

Post-Construction Features: No apparent erosion features were observed around the concrete mattresses.

Scour at the legs is notably less than at WTG-1 and WTG-2. Scour interpreted from the monitoring surveys were observed to be up to approximately 4 to 10cm around the legs.

3.2.5 Wind Turbine Generator 5

Construction Season 1 Features: All of the disturbances (F132–135) that existed in this area prior to the May 2016 survey displayed some slight change related to sediment infilling in the September 2018 bathymetry data (Table C-1).

Construction Season 2 Features: All four of the seafloor disturbance features (F176-F179) that were identified in the Construction Season 2 baseline survey (Survey 2—Oct. 2016) appear to have completely healed and are not discernable in the September 2018 (Survey 5) survey data (Figures 7b, 7c, and Table C-1).

Post-Construction Features: No apparent erosion features were observed around the concrete mattresses.

Scour at the legs is notably less than at WTG-1 and WTG-2. Scour interpreted from the monitoring surveys were observed to be up to approximately 4 to 9cm around the legs.

3.2.6 Recovery from Seafloor Disturbance Elsewhere in the Work Area

Construction Season 1 Features: Based on our review of the Survey 5 data, approximately 44 percent of the Construction Season 1 disturbances appear to be completely healed (Table 3-1). Approximately

18 percent of the seafloor disturbances located outside the immediate vicinity of the WTG's did not appear to have undergone significant change since Survey 4 (October 2017); all other features have completely healed or appear to have undergone some recovery since Survey 4.

Construction Season 2 Features: Based on our review of the Survey 5 data, approximately 69 percent of the Construction Season 2 disturbances appear to be completely healed (Table 3-1). Approximately 4 percent of the seafloor disturbances located outside the immediate vicinity of the WTG's did not appear to have undergone significant change from the Survey 4 (October 2017); all other features have completely healed or appear to have undergone some recovery since Survey 4.

3.2.7 Cable Trench Monitoring

Inter-array cables are located within the designated survey area and were surveyed during each monitoring survey. However, the export cable and transmission cable between Block Island and the mainland were outside the designated monitoring survey area but portions were surveyed as time allowed as described in Section 1.4.1. This section describes the surveys and our observations of the recovery rates of the cable trenches. To assess the recovery of the cable trench after installation, sections of the cable trench scar were measured and designated as recovered or still present. The trench scar was considered to be recovered if trench features were not discernable in the bathymetric data and the seafloor appeared to be restored to its natural topography. The following information and data renderings were created to aid the interpretation:

- Sun-illuminated hill-shaded relief to create a 3D-like rendering of the seafloor and enhance the trench scar features and overspill levees,
- Bathymetric contours at 0.1m intervals, and
- Cross sections at various locations across the trench along the routes.

Chart 7 and Figure 13 present comparisons of pre-lay and post-lay surveys. The following surveys were used to evaluate trench recovery rates. Table 3.3 provides a summary of recovery monitoring assessment.

- Inter-array Cable Routes: All segments were surveyed as part of the Surveys, 1, 2, 3, 4, and 5.
- Export Cable Route from Wind Farm to Block Island:
 - Pre-lay Survey during May 2016 covered approximately 87 percent of route
 - Post-lay Survey during October 2016 covered approximately 95 percent of route
- Block Island Transmission Cable from Block Island to Rhode Island Mainland:
 - Pre-lay covered 61 percent of the route
 - Post-lay during cable installation in July 2016 surveyed approximately 50 percent of route (mainland to mid-way point between Block Island and mainland)
 - Post-lay Survey during October 2016 surveyed approximately 90 percent of the route.



Table 3.3: Summary of Cable Trench Recovery

	Survey Date	Post-lay Survey Length (km)	Trench Length Recovered (Percentage)
Inter-array Cable	Survey 1 (May 2016)	Pre-lay (no cable installed)	
	Survey 2 (Oct 2016)	4.6	0.8 (17%)
	Survey 3 (May 2017)	4.6	1.6 (35%)
	Survey 4 (Oct 2017)	4.6	1.8 (39%)
	Survey 5 (Sep 2018)	4.6	1.9 (41%)
Export Cable (Wind Farm to Block Island)	Survey 1 (May 2016)	Pre-lay (no cable installed)	
	Survey 2 (Oct 2016)	9.1	5.6 (62%)
Block Island Transmission Cable to Mainland	Survey 1 (May 2016)	Pre-lay (no cable installed)	
	July 2016 Survey	19.4	0.5 (3%)
	Survey 2 (Oct 2016)	31.2	3.7 (12%)
Total		44.9	11.2 (25%)

3.2.8 Seafloor Recovery Rates

Seafloor recovery rates are anticipated to vary across the scale of a wind farm. Recovery primarily occurs as bottom currents (1) transport sediments that infill the disturbance features or (2) cause bedforms to organize and shift or migrate. Sediment transport of sediments by bottom currents or shifting/migration of bedforms is dependent upon bottom current speeds, flow direction and duration, and seafloor sediment type. Variation in those parameters will cause sediment mobility, and ultimately the seafloor recovery rates to vary.

The bathymetric data reveal bedforms of varying type, size, and orientation. Bedform type (e.g. ripple or dune) and size are dependent on the bottom current speed, flow direction(s), and sediment type. Stow et al. (2009) and Ashley (1990) have developed interrelationships between sediment type, current speeds, and bedforms. Furthermore, Van Rijn (1993) and Allen (1982) present relationships between bedforms, mobility, and sedimentary environments.

Through comparison of the surveys, we identify areas where bedforms have changed. By delineating areas with common bedforms and monitoring the changes in bedforms using the surveys, we will develop an understanding of how sediment mobility and the seafloor recovery will vary across this site. The periodic bathymetric surveys are being used to refine this understanding and final report will be prepared that summarizes our assessment of seafloor recovery rates at this site. The following section describes our interim evaluation of sediment mobility in the study area.

3.2.8.1 Observed Changes in Bedforms

The survey data reveal bedforms of varying size (both dune and ripple scale) and orientation. Observations from Surveys 1 through 5 indicate that the orientations and locations of individual bedforms and the extents of ripple and dune fields have changed between surveys. Areas where the



bedforms appear to have changed more notably have been associated with areas where seafloor disturbances have undergone a higher sediment infill rate and thus appear to be healing more quickly.

In the region around WTG 2 and between WTG 3 and 4 (Figure 14), dune-scale bedforms (0.5 to 1.5m tall) shifted to the northwest by the following magnitudes:

- 2.5 to 6 meters between Surveys 1 (May 2016) and 3 (May 2017).
- Approximately 3 meters between Survey 3 (May 2017) and Survey 4 (October 2017).
- Approximately 2 meters between Survey 4 (October 2017) and Survey 5 (September 2018).
- Approximately 11 meters in total between Survey 1 and 5 (Figure 14).

Several large ripple fields were observed to either change in spatial extent or size and in orientation between some surveys (Figure 15). Orientation of ripple crestlines in Surveys 1 and 3 were primarily east-west oriented, while in Survey 2 they were primarily northeast-southwest oriented. Observations of ripple crestlines in Survey 4 revealed that their orientation had approximately remained the same (east-west). It was also noted that the ripples in Survey 4 had grown in spatial extent and in height as compared to previous surveys. Ripples observed in Survey 4 were up to 20 cm tall, compared to approximately 10 cm tall in Surveys 1 and 3 and only about 5 cm tall in Survey 2. Although a seasonal change could still be at work, which was postulated in Survey Report 3, the lack of change in orientation and growth of spatial extent and size of the ripples observed in Survey 4 could be due to the occurrence of large storm events that were present in the area shortly before the Survey 4 data was acquired (e.g. Hurricane Jose at the end of September 2017). Ripple crestlines retain an east-west orientation in Survey 5 except for in the area around WTG 1 where the orientation is northeast-southwest and the area around WTG 4 where there appears to be a combination of the two orientations present. Ripples in Survey 5 had reduced in height to approximately 10 cm tall since Survey 4 where they were observed to be up to 20cm tall.

3.2.8.2 Seafloor Recovery Rate Zones

We categorize the survey area into zones based on bedform morphology and changes inferred from data collected during Surveys 1 through 5. Our observations of the survey data indicate that bedforms shift at the site at varying rates and extents of bedform zones (e.g. ripple fields) appear to change over time. We have also inferred the sediment type (e.g. grain size) based on information provided in DW project reports, Fugro's MBES backscatter data collected during Survey 5 (Figure 16), and benthic study grab sampling conducted at WTG 1, WTG 3, and WTG 5 by University of Rhode Island and Fugro during the RODEO program. Correlation between the backscatter data with previously acquired Side Scan Sonar data and grain size data from others, allowed interpretive boundaries to be established and updated for this report (based on the September 2018 survey data). Areas which displayed a high intensity on the backscatter indicate a harder return and suggested coarse material. Conversely, areas which experienced a lower intensity, suggested a finer grained material (e.g. fine sand).

We have evaluated recovery rates for the for various zones using the MBES data and interpretation from the Surveys 1 through 5. Recovery rates are variable across the site and related to seabed sediment type and morphology. The contrast between recovery rates can be abrupt over short distances as observed at WTG 4 in Figures 6b and 6c. In Figure 6b, two of the L.B Brave Tern spud depression are completed recovered and two are still present. The horizontal distance between the



spud depressions that completely recovered and the two still present is only approximately 150 meters which suggests the sediment type is a primary factor in sediment reworking and seafloor recovery. The seafloor recovery zones shown in Figure 15 are described in the following section and summarized in Table 3.4.

Table 3.4: Seafloor Recovery per Zone

	Percent of Disturbed Area Completely Healed at Time of Survey 5	Comment
Zone 1 – High Seafloor Recovery Rate	82%	Area of dynamic ripples and predominantly medium- to coarse-grained sand
Zone 2 – Moderate Seafloor Recovery Rate	32%	Area of ripple to dune scale bedforms and predominantly fine-grained sand
Zone 3 – Low Seafloor Recovery Rate	0%	Coarse sand, gravel, and cobbles

Zone 1 – High Seafloor Recovery Rate. This zone is characterized by abundant ripples that appeared to change in size, extent, and orientation between the surveys. Seafloor sediment type is predominantly medium- to coarse-grained sand with low fine-grained sediment (particle size less than 0.075mm) content. Side scan sonar reflectivity is high and MBES backscatter intensity values are typically between -20 and -25 db. Seafloor disturbance recovery rates were approximately 2.5 times higher than in Zone 2 (Table 3.4).

Zone 2 – Moderate Seafloor Recovery Rate. This zone is characterized by sand accumulation areas that appear to be migrating over coarser sediments. The side scan sonar reflectivity is generally low and MBES backscatter intensity values are typically between -27 and -30 db. Sediment type is inferred to be predominantly fine to medium-grained sand with low amount of fine-grained sediment (particle size less than 0.075mm). The sand accumulation bodies are approximately 0.5 to 1m tall and fall within a dune scale size. Figure 14 presents examples of these sand accumulation features and interpreted to be moving at rates of approximately 1 to 3m per year in a northwesterly direction.

Zone 3 – Low Seafloor Recovery Rate. This zone contained the coarsest seafloor sediment and slowest recovery. Seafloor sediment is predominantly sand, gravel, and cobbles. This zone is confined to the southwest portion of the survey area and no turbines or cables were installed in this zone.

4. SUMMARY

The Seafloor Disturbance and Recovery Monitoring Program is using periodic multibeam bathymetric surveys to identify disturbances of the seafloor that resulted from wind farm construction activities. The periodic surveys are also being used to monitor recovery from those disturbances. The monitoring surveys are encompassing the area denoted by DW as the “Work Area.” The Work Area is the region where construction vessels were authorized to anchor or set spuds during construction.

The Block Island Wind Farm was constructed during two construction seasons. The jacket foundations were installed during Construction Season 1 which occurred in 2015 and ended in mid-December. Survey 1 was conducted in May 2016 and represents the baseline survey for Construction Season 1 disturbance monitoring. The survey activities and results from that survey were provided in our Survey 1 Report.

During Construction Season 2, which occurred in 2016, towers, nacelles, blades, inter-array cables, and export cables were installed. Also, during 2016, concrete mats were placed on cable sections that were intentionally left unburied near the turbines to allow the cables to be pulled into the turbine. Survey 2 was conducted at the end of Construction Season 2 in October 2016 and represents the baseline survey for Construction Season 2 disturbance monitoring. The survey activities and results from that survey were provided in our Survey 2 Report.

After completion of all construction activities, the following monitoring surveys were conducted. A report was issued after each survey and summarized the seafloor recovery progress. Those surveys included:

- Survey 3 (May of 2017)
- Survey 4 (October 2017)
- Survey 5 (September 2018)

Construction Season 1 (2015) created 139 disturbance features that comprise an area of approximately 10,319 m². Survey 5 (September 2018) revealed that 70 of those features had partially healed and 90 had completely healed. The completely healed features comprise an area of 5,122 m² which indicates approximately 50 percent of the disturbed area has completely healed (Table 3.1).

Construction Season 2 (2016) created 101 disturbance features that comprise an area of approximately 6,876 m². Survey 5 (September 2018) revealed that 17 of those 101 disturbance features had partially healed and 86 had completely healed. The completely healed features comprise an area of 4,805 m² which indicates that approximately 70 percent of the disturbed area has completely healed (Table 3.1).

Seafloor disturbance related to the installation of a wind turbine was assessed for each turbine location. Based on the spatial extent of disturbances, we assumed that installation activity disturbance was confined to within approximately 175 meters of each turbine. Seafloor disturbance and percentage of disturbed area within 175 meters of the turbine were evaluated.

- Temporary features from construction activities (e.g. jacking-up of a vessel) were estimated to disturb between approximately 1,100 m² to 3,100 m² of seafloor area or approximately 1.1 to 3.2 percent of the area within 175 meters of the turbines.

- Cable trench scars were estimated to disturb between approximately 1,040 m² and 1,700 m² or approximately 1.1 to 1.8 percent of the area at each turbine.
- Long-term features related to foundation piles and scour is estimated to impact approximately 110m² to 310m² or approximately 0.1 to 0.3 percent of the area at each turbine.
- Long-term features related to concrete mattresses placed on the cables at the turbine area is estimated to impact approximately 425 m² to 1,075 m² or 0.4 to 1.1 percent of the area at each turbine.
- The total disturbance related to temporary and long-term features, cable trench scars is estimated to be approximately 2,600 m² to 5,700 m² or approximately 2.7 to 6.0 percent of the area around each turbine.

We interpreted seafloor recovery rate zones based on seafloor characteristics and morphology inferred from the MBES, side scan sonar, and sediment grain size data (Figure 15).

- Zone 1 – High Recovery Rate: 82 percent of the seafloor disturbance had completely healed by Survey 5
- Zone 2 – Moderate Recovery Rate: 32 percent of the seafloor disturbance had completely healed by Survey 5
- Zone 3 – Low Recovery Rate: None of the disturbance features had completely healed by Survey 5

Recovery of cable trench scars was also evaluated. The inter-array cable was surveyed during each monitoring survey. Approximately 41 percent of the inter-array cable trench scar appears to have completely healed by September 2018 (Survey 5). The export cable and Block Island transmission cable were surveyed when time allowed. Comparison between pre-lay and post-lay cable surveys revealed that approximately 12 percent of the Block Island transmission cable trench scar had completely healed, and that 62 percent of the export cable trench scar had completely healed by October 2016 (Survey 2). The variance in recovery rates is likely due to a combination of factors, including water depth, grain size, and bottom current speeds.

Introduction of structures can modify near-bottom current flow processes and induce scour. The Block Island Wind Farm installed four-legged jacket foundations and placed concrete mattresses on sections of cable near the turbines that were intentionally left unburied. Sections of the cable near the turbines were left unburied to allow them to be pulled into the turbine. Concrete mattresses were placed on the unburied sections to provide protection to the cables. The monitoring surveys revealed that small erosional features had developed adjacent to east-west oriented mattresses at WTG 1 and WTG 2 (Figures 9b and 10b). The east-west oriented concrete mattresses are nearly perpendicular to the principle tidal axis which is inferred to be NNW-SSW direction. The scour features were notably larger on the northwest side of concrete mattresses. The scour features were up about 5 to 25 cm deep and extended approximately 1 to 3 meters from the mattresses. Sections of cable and mattresses oriented north-south did not appear to exhibit scour. The bias of scour development to the north-northwest suggest the flood tidal current is dominant in the area of WTG 1 and WTG 2. The extent and depth of scour did not appear to change significantly between Surveys 3, 4, and 5. Scour was not observed adjacent to concrete mattresses at WTG 3, WTG 4, and WTG 5.

Scour at the turbine legs was interpreted to be fairly small based on the multibeam surveys. Scour depths of 10 to 25 cm were interpreted at the legs. WTG 1 and WTG 2 exhibited the deepest scour. Multibeam surveys provide an instantaneous snapshot of scour conditions at a location. Scour is a dynamic process that can develop and infill during tidal cycles, discrete storm events, seasonal variations or other types of variations in oceanographic processes. A recently developed scour monitoring system was used to continuously monitor scour and infill variations that were not observed in multibeam surveys. WTG 3 had scour monitors installed for a period of 14 months that were used to continuously monitor seabed elevations. The scour monitors recorded seabed level changes of up to approximately:

- 0.2m over tidal cycles and
- 0.6m over one-month periods (included storm events).

The scour monitors captured storm events, monthly, and seasonal scour development, infill processes and seafloor elevation variations that were not captured by the periodic multibeam surveys. Details of the scour monitoring system evaluation are provided the Scour Monitor and AWAC Recovery Operation Report (Fugro, 2018) The two monitoring programs provide a comparison of methods that can be used to monitor scour and seafloor changes at wind farms.

5. REFERENCES

Allen, J.R. (1982) *Sedimentary Structures: Their Character and Physical Basis*. Elsevier, New York, NY.

Ashley, G.M. (1990), "Classification of Large-Scale Subaqueous Bedforms: A New Look at an Old Problem," *Journal of Sedimentary Petrology*, Vol. 60, pp. 363-396.

Fugro (2016) *Seafloor Disturbance and Recovery Monitoring Program, Survey 1 May 2016*. Fugro Project No. 04.81150001, prepared for HDR. Issued on September 7, 2016.

Fugro (2017a) *Seafloor Disturbance and Recovery Monitoring Program, Survey 2 October 2016*. Fugro Project No. 04.81150001, prepared for HDR. Issued on June 8, 2017.

Fugro (2017b) *Seafloor Disturbance and Recovery Monitoring Program, Survey 3 May 2017*. Fugro Project No. 04.81150001, prepared for HDR. Issued on June 1, 2017.

Fugro (2017c) *Seafloor Disturbance and Recovery Monitoring Program, Survey 4 October 2017*. Fugro Project No. 04.81150001, prepared for HDR. Issued on November 13, 2017.

Fugro (2018) *Block Island Wind Farm, Scour Monitor and AWAC Recovery Operation Report, Block Island Wind Farm, USA*. Fugro Report No. 160215-5, prepared for HDR. Issued on January 29, 2018.

Stow, Dorrik A.V., Hernández-Molina, Javier, Llave, Estefania, Sayago-Gil, Miriam, del Río, Victor Díaz, and Branson, Adam (2009), "Bedform-velocity matrix: The estimation of bottom current velocity from bedform observations," *Geology*, v.37, no. 4, p.327-330.

Van Rijn, L.C. (1993) *Principle of Fluid Flow and Surface Waves in Rivers, Estuaries, Seas, and Ocean*. Aqua, Amsterdam, The Netherlands.

FIGURES

N:\Projects\04_2015\04_8115_0001_BOEM_RODEO\BlockIsland_R10\Outputs\Post_Con_Survey_5\IMXD\Fig-1_Study_Area.mxd, 1/11/2019, T.Weathers

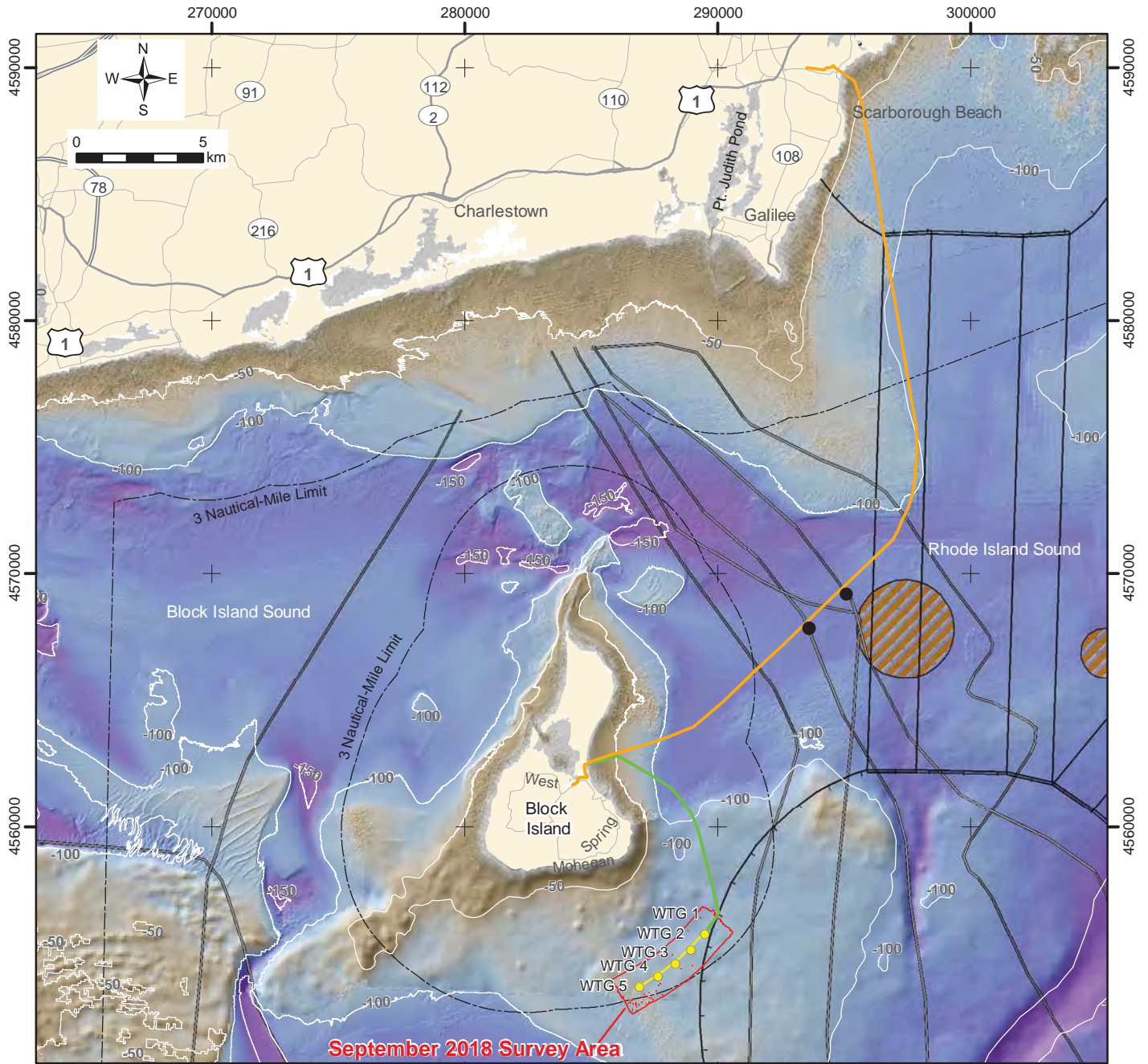

Legend

Block Island Wind Farm

- Turbine
- Active Cable Crossing
- BITS Alternative 1
- Export Cable
- Inter Array Cable

Bathymetry (MLLW, ft)

- Source: compiled NOAA survey data
- Contour interval is 50 ft.
 - High : 0
 - Low : -220

Base Map

- Submarine Cable
 - 3 Nautical Mile State Limit
 - Precautionary Area
 - Traffic Separation Scheme Lane
 - Dumping Ground Area
 - +
- Coordinate Grid: UTM Zone 19N, NAD83, Meters

STUDY AREA
Seafloor Monitoring Study
Block Island Wind Farm and Transmission Project
Offshore Rhode Island

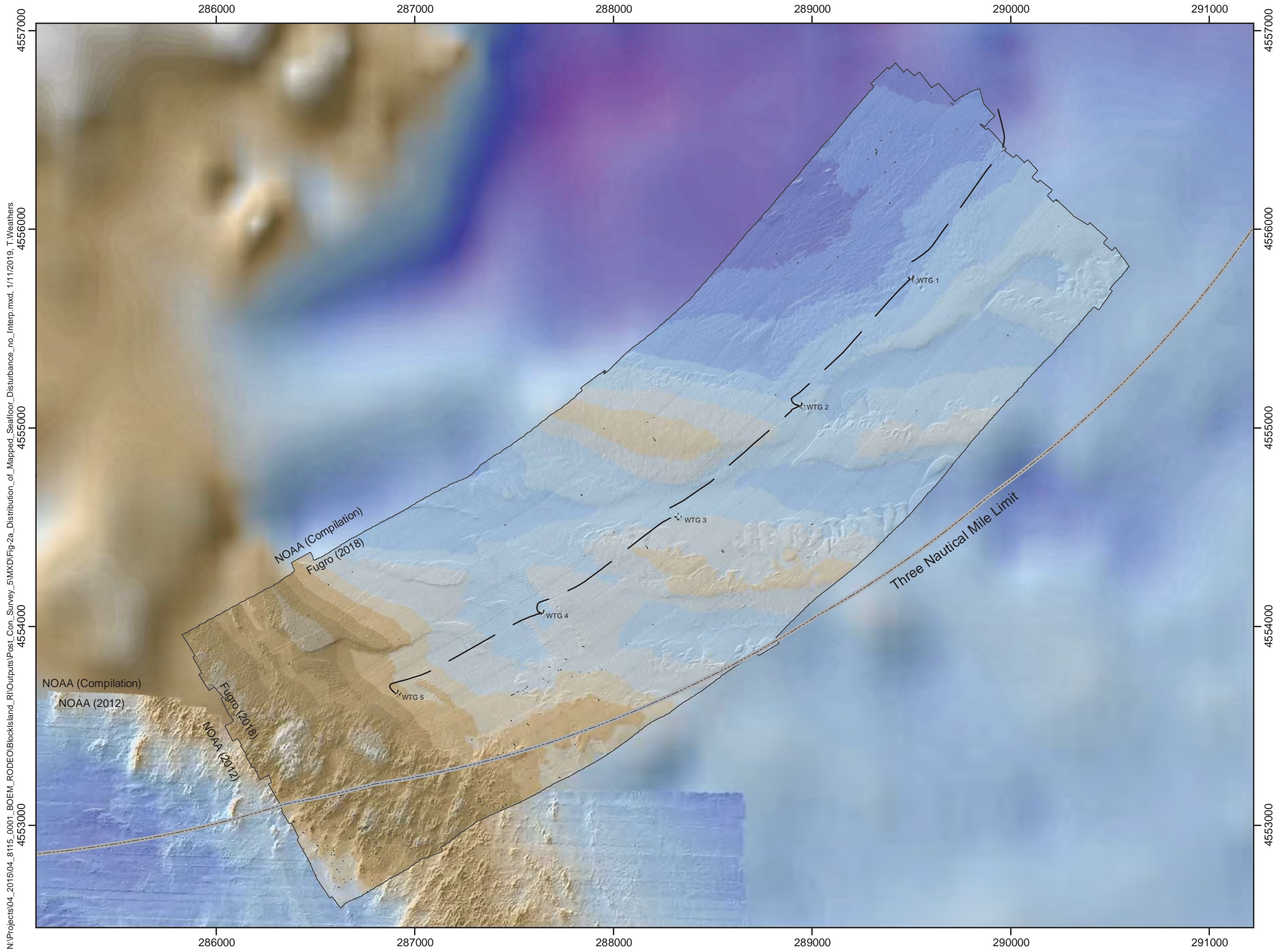

Legend

- Export Cable/Inter Array Cable
- Three Nautical Mile State Limit

Bathymetry (Meter, MLLW)

Lower than -33	-26 to -25
-33 to -32	-25 to -24
-32 to -31	-24 to -23
-31 to -30	-23 to -22
-30 to -29	-22 to -21
-29 to -28	-21 to -20
-28 to -27	-20 to -19
-27 to -26	-19 to -18

Notes:

1. Fugro 2018 multibeam bathymetry was collected on September 29 and 30, 2018.
2. NOAA (2012) multibeam bathymetric data is from the National Oceanic and Atmospheric Administration's (NOAA) hydrographic survey of Block Island Sound, New York. This survey was conducted August 25 through August 29, 2012.
3. Bathymetric data is a compilation of NOAA sounding files in the area that were collected between 1938 to 1979.



Coordinate System: UTM 19N, NAD83, Meter

FUGRO September 2018 BATHYMETRY
Seafloor Monitoring Study
Block Island Wind Farm and Transmission Project
Offshore Rhode Island

N:\Projects\04_2015\04_8115_0001_BOEM_RODEO\BlockIsland_RI\Outputs\Post_Con_Survey_5\IMXD\Fig-2a_Distribution_of_Mapped_Seafloor_Disturbance_no_Interp.mxd, 1/11/2019, T.Weathers

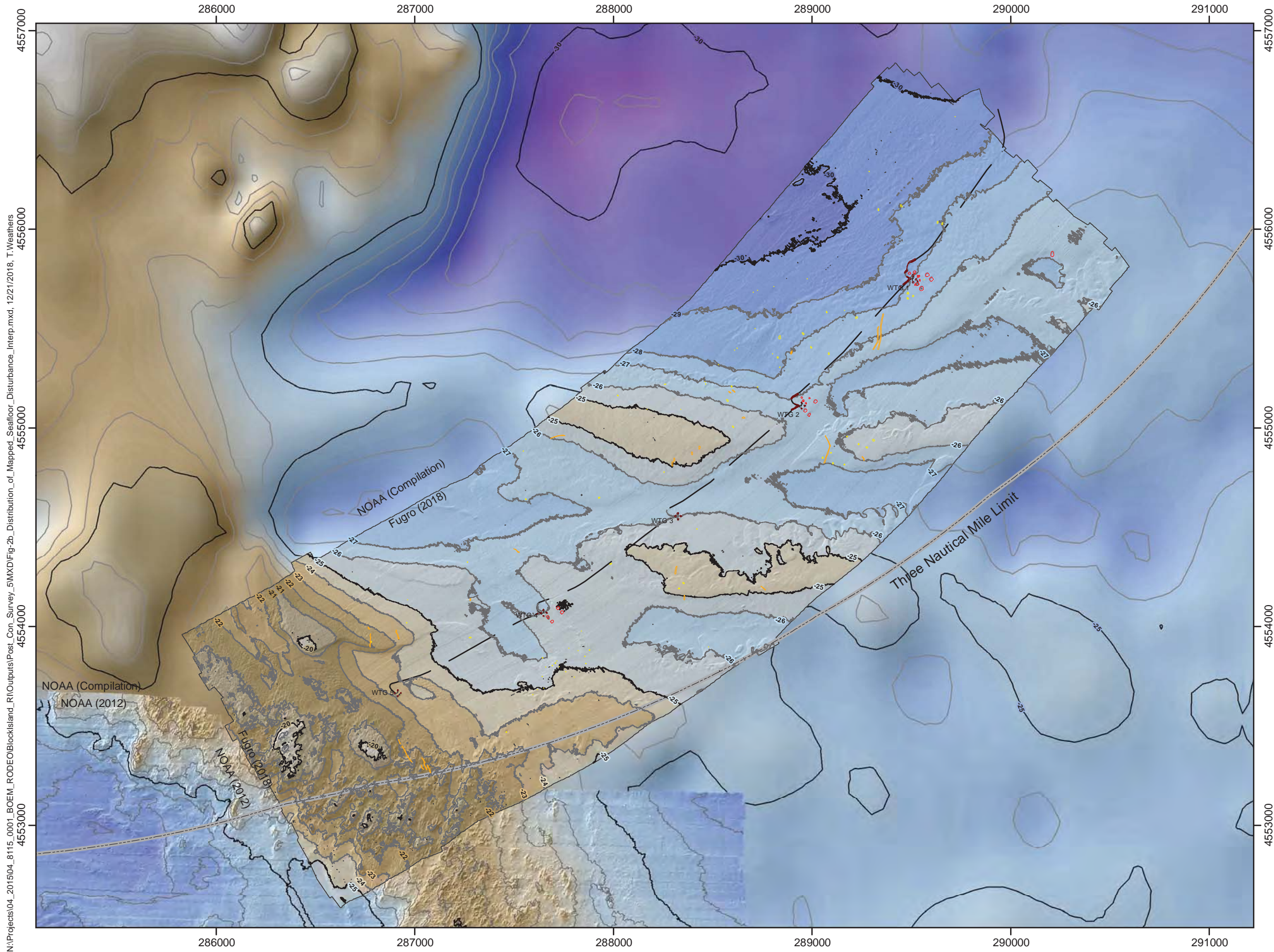

Legend

- Export Cable/Inter Array Cable
- Three Nautical Mile State Limit

Bathymetry (Meter, MLLW)

	Lower than -33		-26 to -25
	-33 to -32		-25 to -24
	-32 to -31		-24 to -23
	-31 to -30		-23 to -22
	-30 to -29		-22 to -21
	-29 to -28		-21 to -20
	-28 to -27		-20 to -19
	-27 to -26		-19 to -18

- Contour interval is 5 meters.
- Contour interval is 1 meter.

Interpreted Seafloor Disturbance Features

- Spud Location
- Scour
- Linear Feature (Possible Drag Mark)
- Circular Depression

Notes:

1. Fugro 2018 multibeam bathymetry was collected on September 29 and 30, 2018.
2. NOAA (2012) multibeam bathymetric data is from the National Oceanic and Atmospheric Administration's (NOAA) hydrographic survey of Block Island Sound, New York. This survey was conducted August 25 through August 29, 2012.
3. Bathymetric data is a compilation of NOAA sounding files in the area that were collected between 1938 to 1979.



Coordinate System: UTM 19N, NAD83, Meter

**INTERPRETED SEAFLOOR
DISTURBANCE FEATURES**
Seafloor Monitoring Study
Block Island Wind Farm and Transmission Project
Offshore Rhode Island

N:\Projects\04_2015\04_8115_0001_BOEM_RODEOBlockIsland_R1\Outputs\Fig-2b_Distribution_of_Mapped_Seafloor_Disturbance_Interp.mxd, 12/21/2018, T:\Weathers

N:\Projects\04_2015\04_8115_0001_BOEM_RODEO\BlockIsland_RI\Outputs\Post_Con_Survey_5\IMXD\Fig-3a_WTG1_Bathymetry_with_Contours.mxd, 1/1/2019, T.Weathers

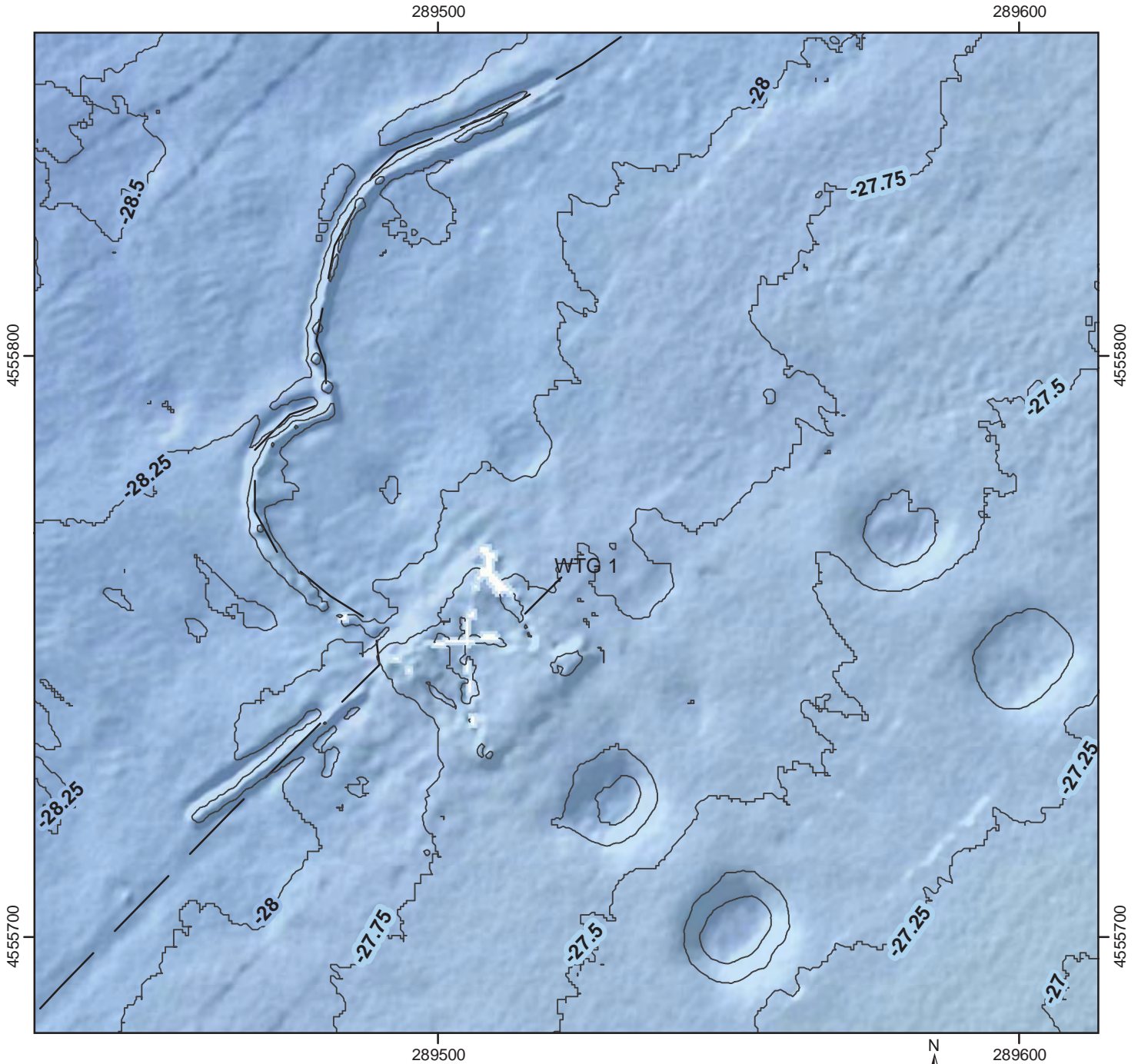

Legend

— Export Cable/Inter Array Cable

**September 2018 Fugro Bathymetry
(Meter, MLLW)**

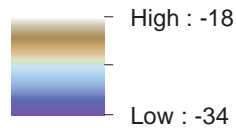

— Contour interval is 0.25 meters



Coordinate System: UTM 19N, NAD83, Meter

**BATHYMETRY
WIND TURBINE GENERATOR NO. 1**
Seafloor Monitoring Study
Block Island Wind Farm and Transmission Project
Offshore Rhode Island

N:\Projects\04_2015\04_8115_0001_BOEM_RODEO\BlockIsland_RI\Outputs\Post_Con_Survey_5\MXD\Fig-3b_WTG1_Bathymetry_with_Interp.mxd, 1/11/2019, T.Weathers

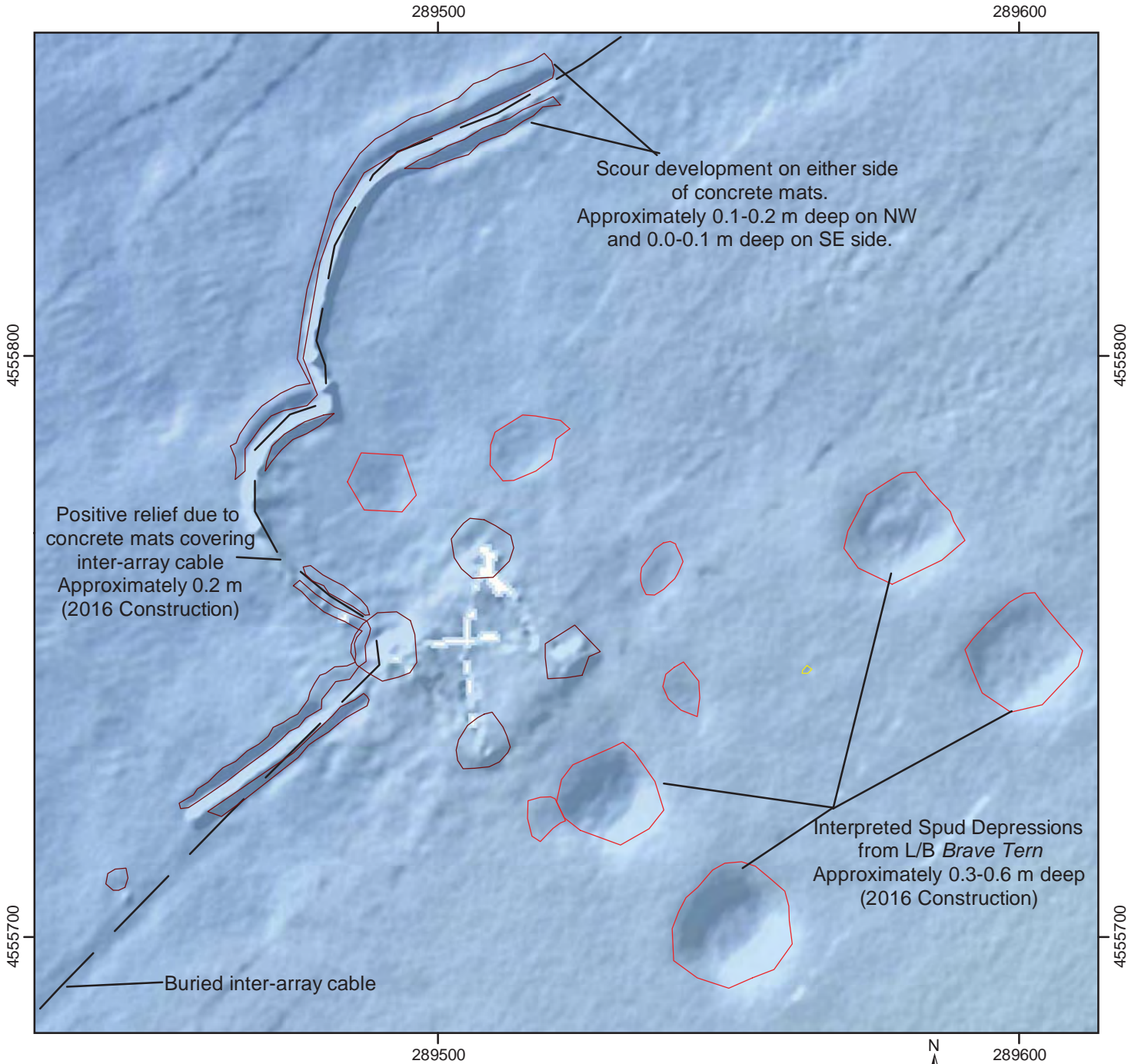

Legend

— Export Cable/Inter Array Cable

Interpreted Seafloor Disturbance Features

- Spud
- Circular Depression
- Scour

September 2018 Fugro Bathymetry (Meter, MLLW)

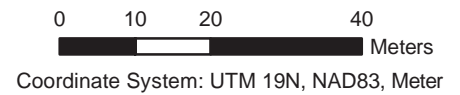
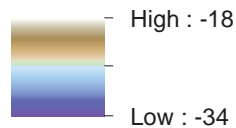

INTERPRETED SEAFLOOR DISTURBANCE TYPES
WIND TURBINE GENERATOR NO. 1
Seafloor Monitoring Study
Block Island Wind Farm and Transmission Project
Offshore Rhode Island

N:\Projects\04_2015\04_8115_0001_BOEM_RODEO\BlockIsland_RIV\Outputs\Post_Con_Survey_5M\XD\Fig-3c_WTG1_Bathymetry_with_Interp.mxd, 7/15/2019, k.smith

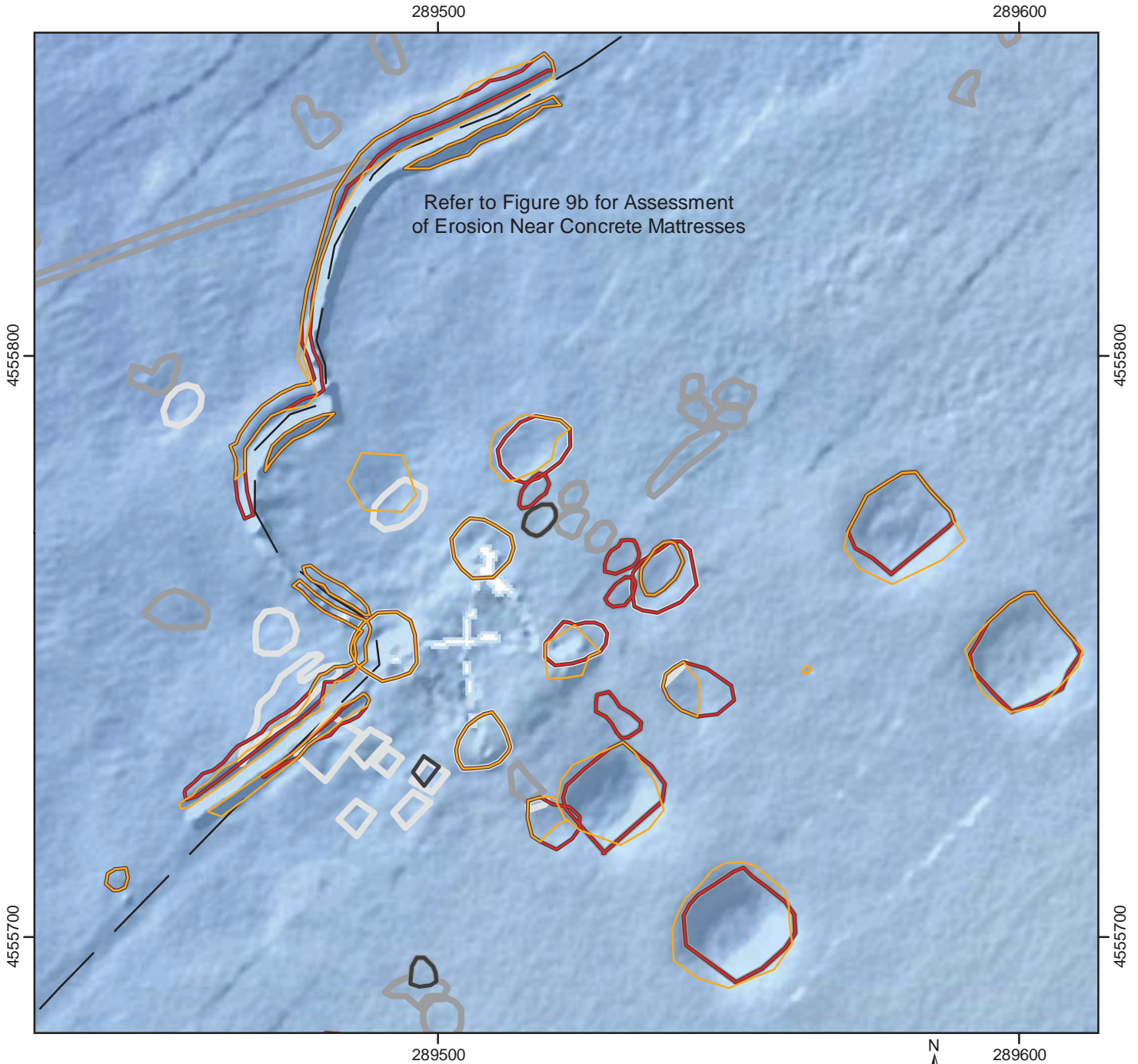

Legend

- Export Cable/Inter Array Cable
- Interpreted Seafloor Disturbance Features**
- Construction Season 1 (May 2016 Data)
- Construction Season 2 (Oct. 2016 Data)
- May 2017 Data □ Sep. 2018 Data
- Oct. 2017 Data

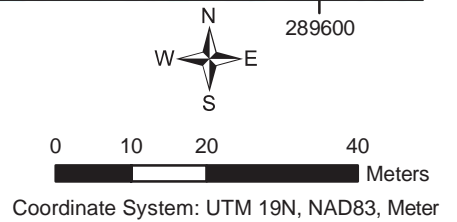

**SEAFLOOR DISTURBANCE PER SURVEY
WIND TURBINE GENERATOR NO. 1**
Seafloor Monitoring Study
Block Island Wind Farm and Transmission Project
Offshore Rhode Island

N:\Projects\04_201504_8115_0001_BOEM_RODEO\BlockIsland_RI\Outputs\Post_Con_Survey_5\MXD\Fig-3d_WTG1_Bathy_Differences.mxd, 8/23/2019, k.smith

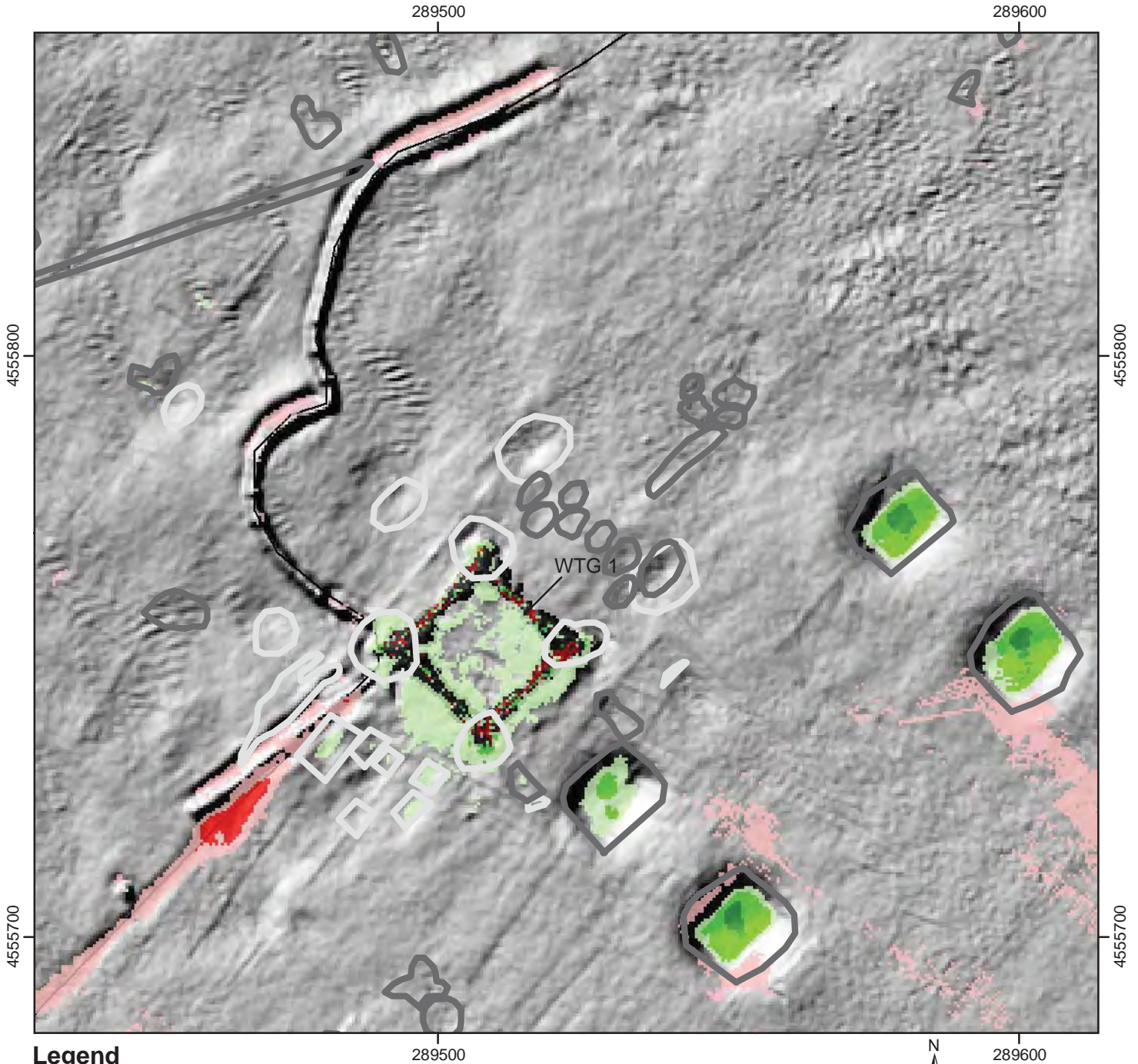

Legend

- Difference between Survey 2 and 4 (meters)**
- More than 0.75
 - 0.75 to 0.5
 - 0.5 to 0.25
 - 0.25 to 0.1
 - 0.1 to 0.1 (No notable change in elevation)
 - 0.1 to -0.25
 - 0.25 to -0.5
 - 0.5 to -0.75
 - More tha -0.75
- Export Cable/Inter Array Cable

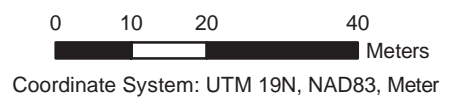

**DIFFERENCE BETWEEN SURVEY 2 AND 4 BATHYMETRY
WIND TURBINE GENERATOR NO. 1**
Seafloor Monitoring Study
Block Island Wind Farm and Transmission Project
Offshore Rhode Island

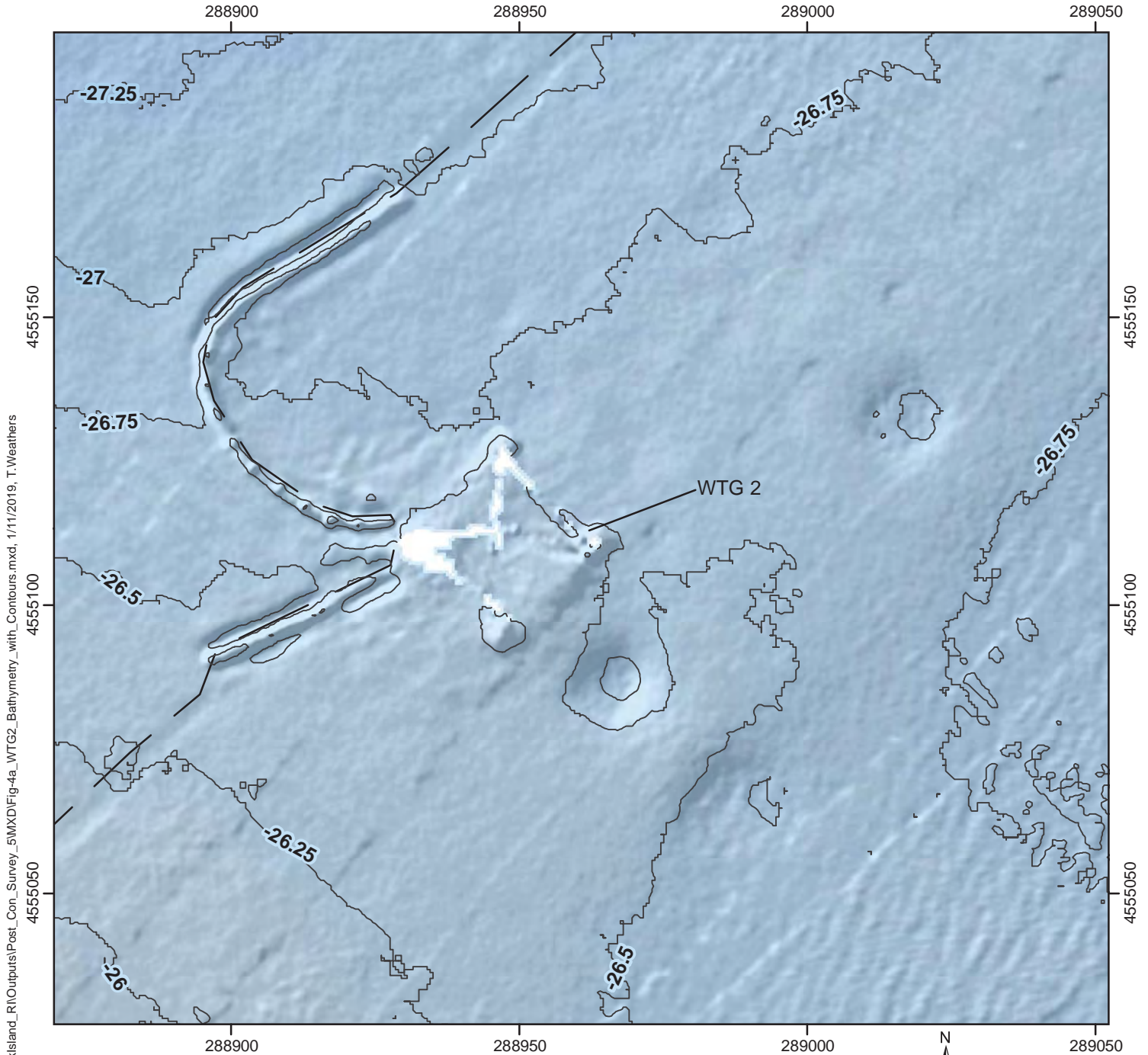

Legend

— Export Cable/Inter Array Cable

**September 2018 Fugro Bathymetry
(Meter, MLLW)**

High : -18



Low : -34

— Contour interval is 0.25 meters



Coordinate System: UTM 19N, NAD83, Meter

**BATHYMETRY
WIND TURBINE GENERATOR NO. 2**
Seafloor Monitoring Study
Block Island Wind Farm and Transmission Project
Offshore Rhode Island

N:\Projects\04_2015\04_8115_0001_BOEM_RODEO\BlockIsland_RIVOutputs\Post_Con_Survey_51MXD\Fig-4a_WTG2_Bathymetry_with_Contours.mxd, 1/11/2019, T.Weathers

N:\Projects\04_2015\04_8115_0001_BOEM_RODEO\BlockIsland_RIVOutputs\Post_Con_Survey_5M\XD\Fig-4b_WT02_Bathymetry_with_Interp.mxd, 1/11/2019, T.Weathers

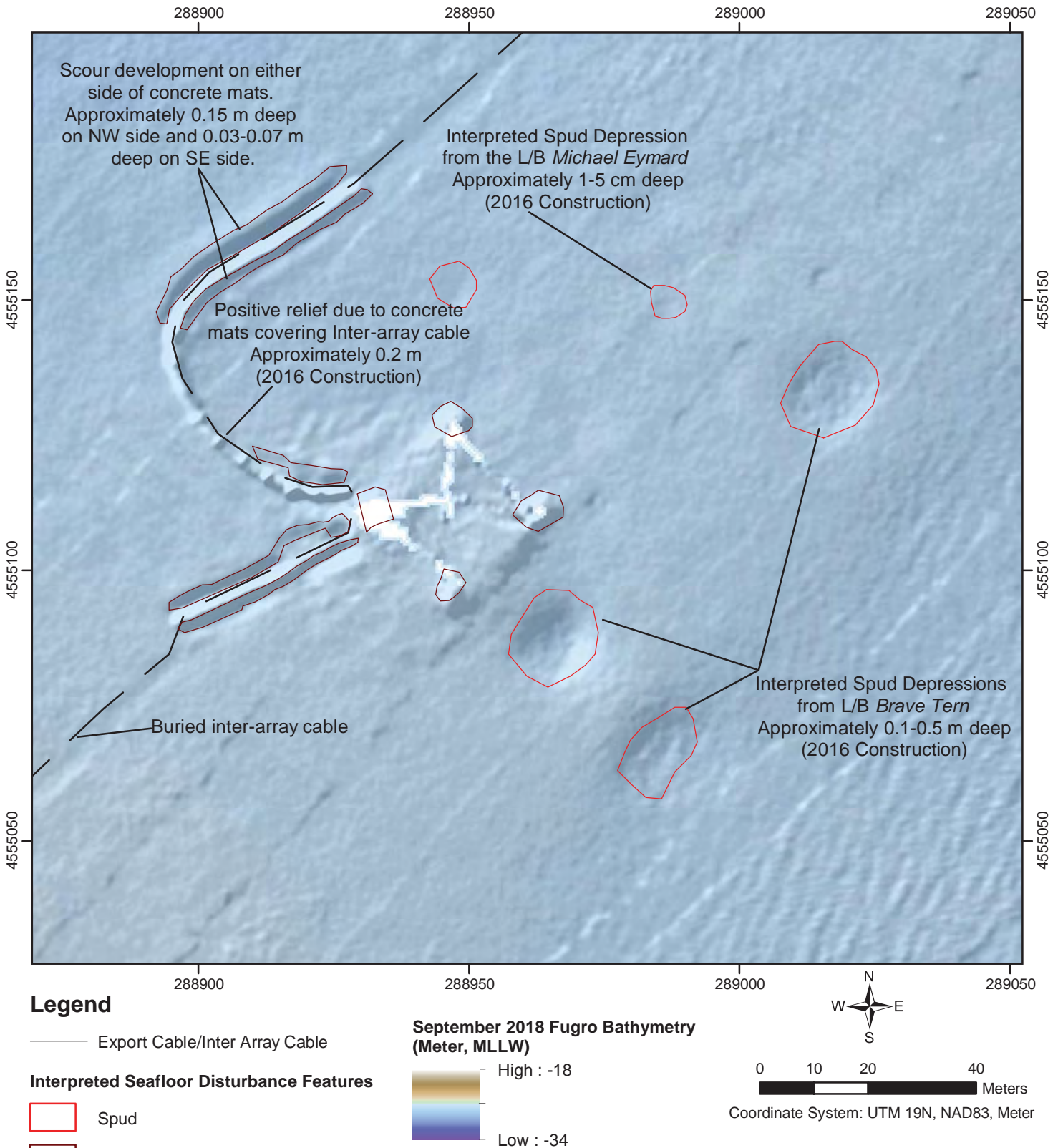

INTERPRETED SEAFLOOR DISTURBANCE TYPES
WIND TURBINE GENERATOR NO. 2
Seafloor Monitoring Study
Block Island Wind Farm and Transmission Project
Offshore Rhode Island

N:\Projects\04_2015\04_8115_0001_BOEM_RODEO\BlockIsland_RIVOutputs\Post_Con_Survey_5M\XD\Fig-4c_WT62_Bathymetry_with_Interp.mxd, 1/11/2019, T.Weathers

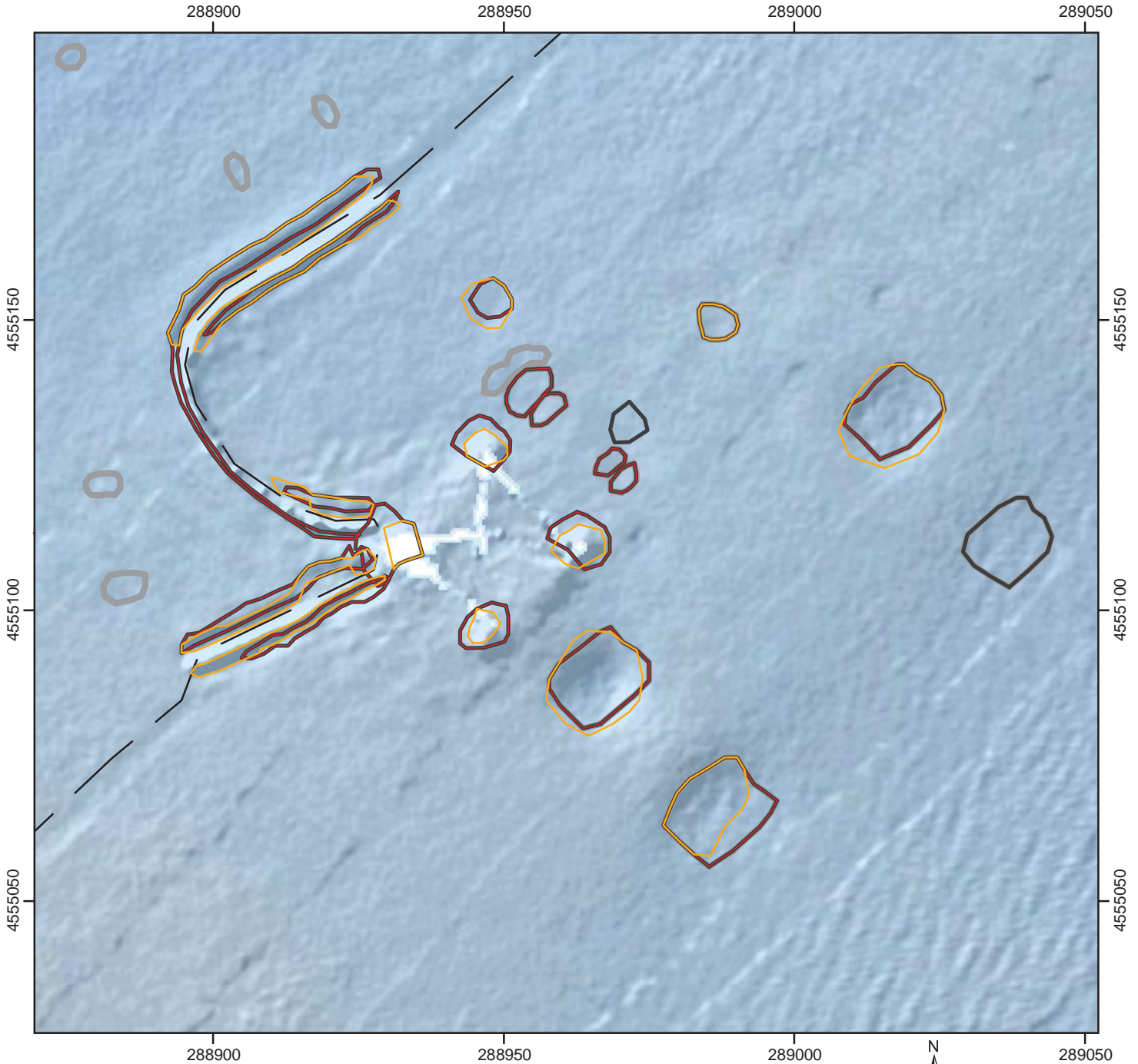

Legend

- Export Cable/Inter Array Cable
- Interpreted Seafloor Disturbance Features**
- Construction Season 1 (May 2016 Data)
- Construction Season 2 (Oct. 2016 Data)
- May 2017 Data □ Sep. 2018 Data
- Oct. 2017 Data

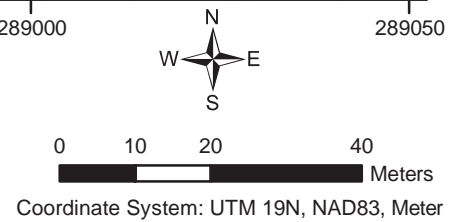

**SEAFLOOR DISTURBANCE PER SURVEY
WIND TURBINE GENERATOR NO. 2**
Seafloor Monitoring Study
Block Island Wind Farm and Transmission Project
Offshore Rhode Island

N:\Projects\04_2015\04_8115_0001_BOEM_RODEO\BlockIsland_RI\Outputs\Post_Con_Survey_5\MXD\Fig-4d_WTG2_Bathy_Differences.mxd, 8/23/2019, k.smith

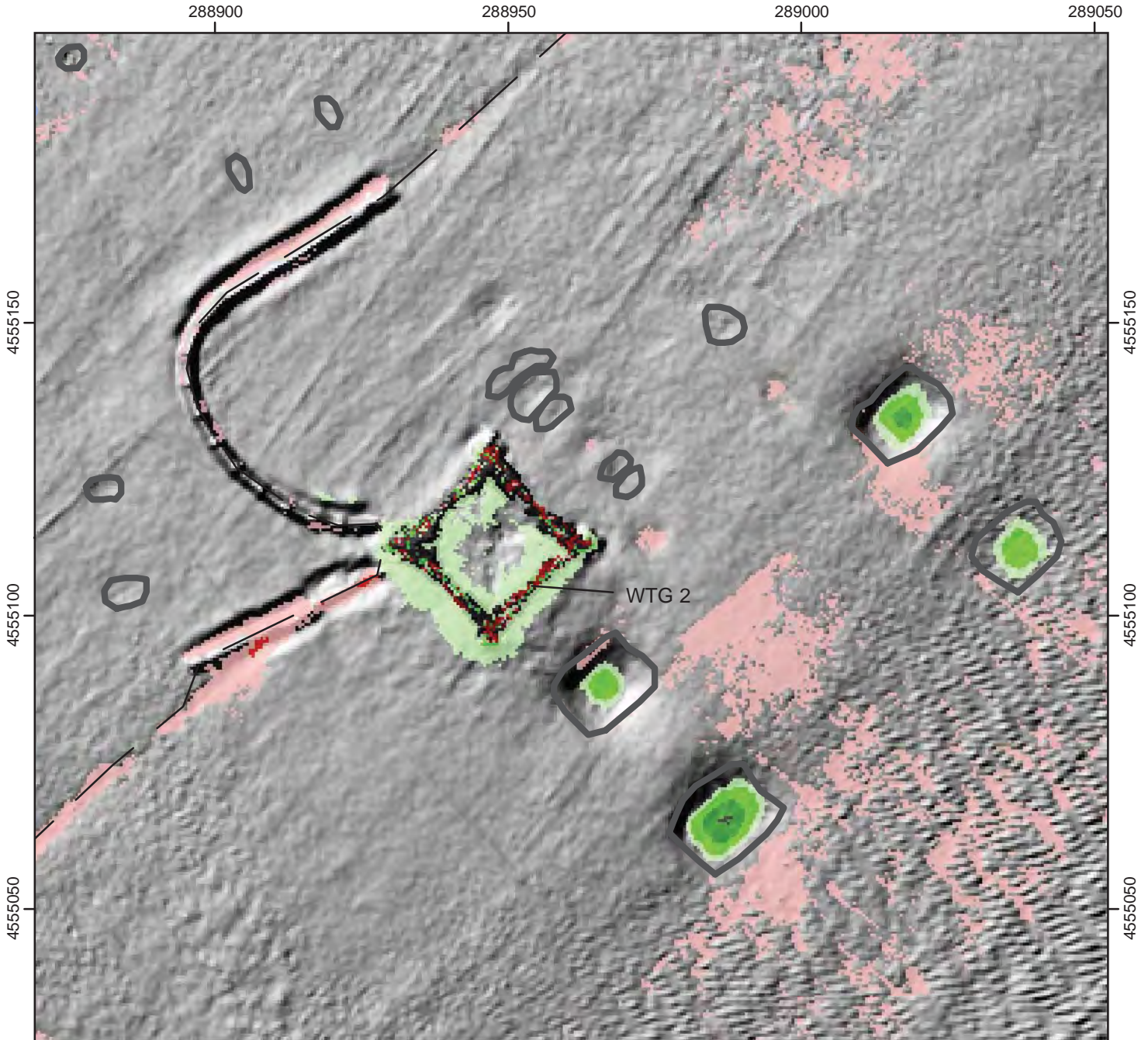

Legend

Difference between Survey 2 and 4 (meters)

- | | | |
|----------------------|--|--|
| Accretion | | More than 0.75 |
| | | 0.75 to 0.5 |
| | | 0.5 to 0.25 |
| | | 0.25 to 0.1 |
| Lowering/
Erosion | | -0.1 to 0.1 (No notable change in elevation) |
| | | -0.1 to -0.25 |
| | | -0.25 to -0.5 |
| | | -0.5 to -0.75 |
| | | More than -0.75 |

Export Cable/Inter Array Cable



Coordinate System: UTM 19N, NAD83, Meter

BATHYMETRY DIFFERENCES
WIND TURBINE GENERATOR NO. 2
 Seafloor Monitoring Study
 Block Island Wind Farm and Transmission Project
 Offshore Rhode Island



N:\Projects\04_2015\04_8115_0001_BOEM_RODEO\BlockIsland_RIVOutputs\Post_Con_Survey_5M\XD\Fig-5a_WTG3_Bathymetry_with_Contours.mxd, 1/11/2019, T.Weathers

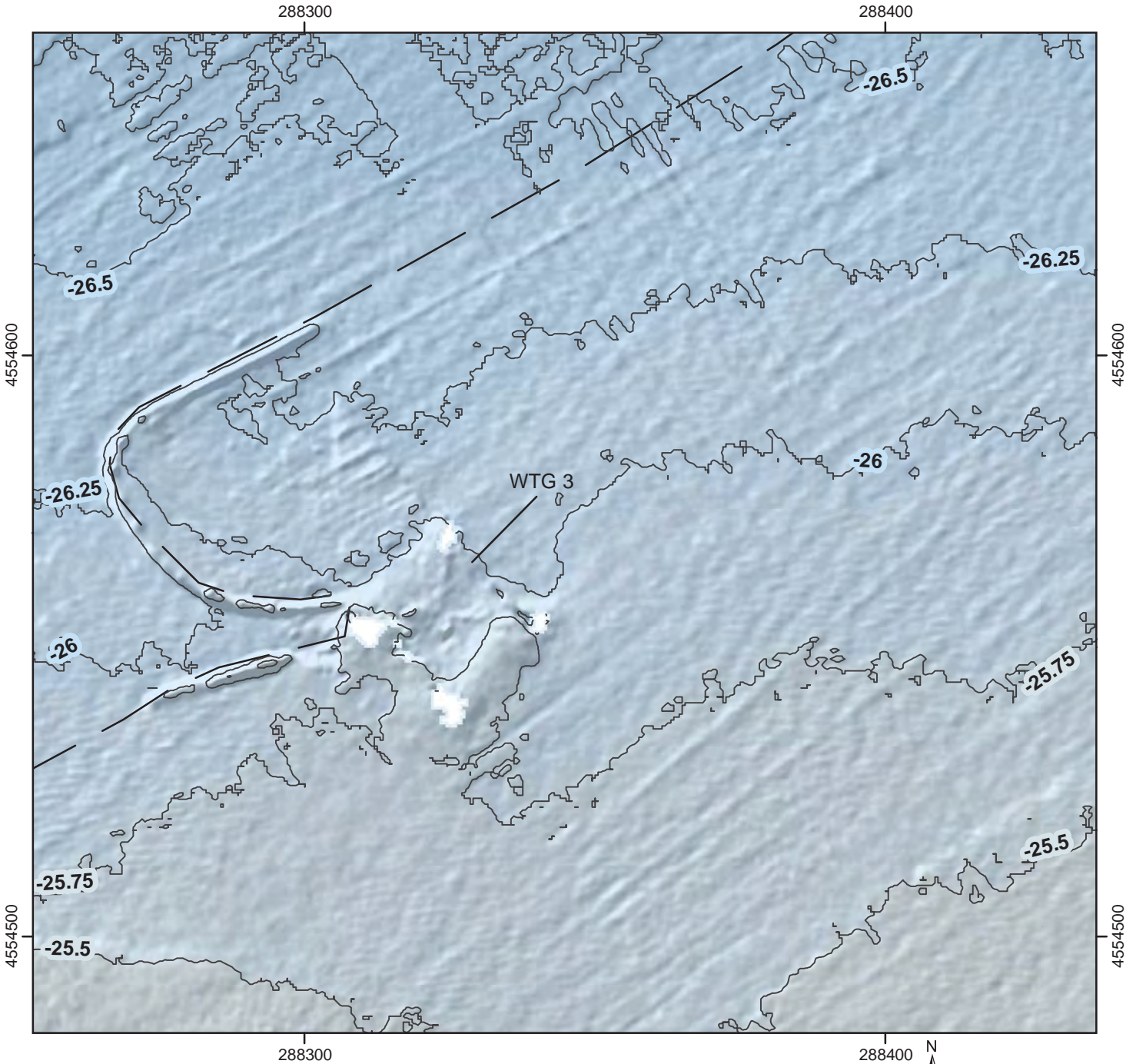

Legend

— Export Cable/Inter Array Cable

**September 2018 Fugro Bathymetry
(Meter, MLLW)**

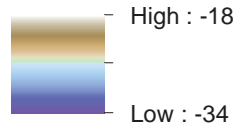

— Contour interval is 0.25 meters

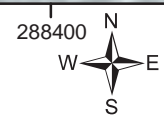

Coordinate System: UTM 19N, NAD83, Meter

**BATHYMETRY
WIND TURBINE GENERATOR NO. 3
Seafloor Monitoring Study
Block Island Wind Farm and Transmission Project
Offshore Rhode Island**

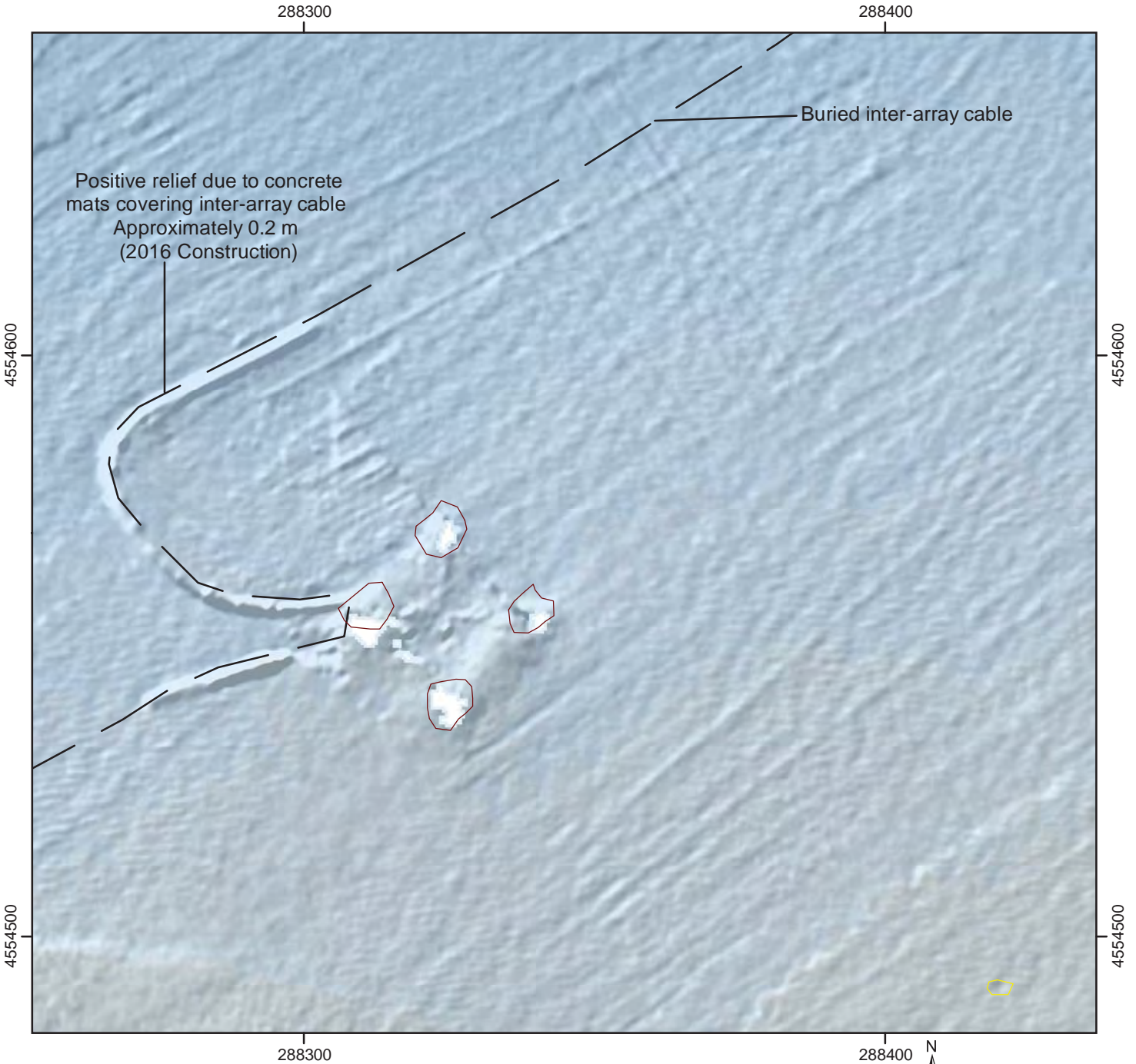

Legend

— Export Cable/Inter Array Cable

Interpreted Seafloor Disturbance Features

- Circular Depression
- Scour

**September 2018 Fugro Bathymetry
(Meter, MLLW)**

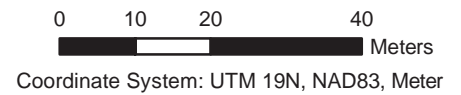
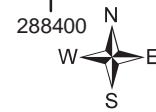
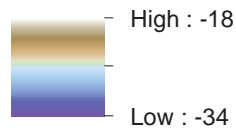

**INTERPRETED SEAFLOOR DISTURBANCE TYPES
WIND TURBINE GENERATOR NO. 3**
Seafloor Monitoring Study
Block Island Wind Farm and Transmission Project
Offshore Rhode Island

N:\Projects\04_2015\04_8115_0001_BOEM_RODEO\BlockIsland_RIVOutputs\Post_Con_Survey_51MXD\Fig-5b_WTGS_Bathymetry_with_Interp.mxd, 1/11/2019, T.Weathers

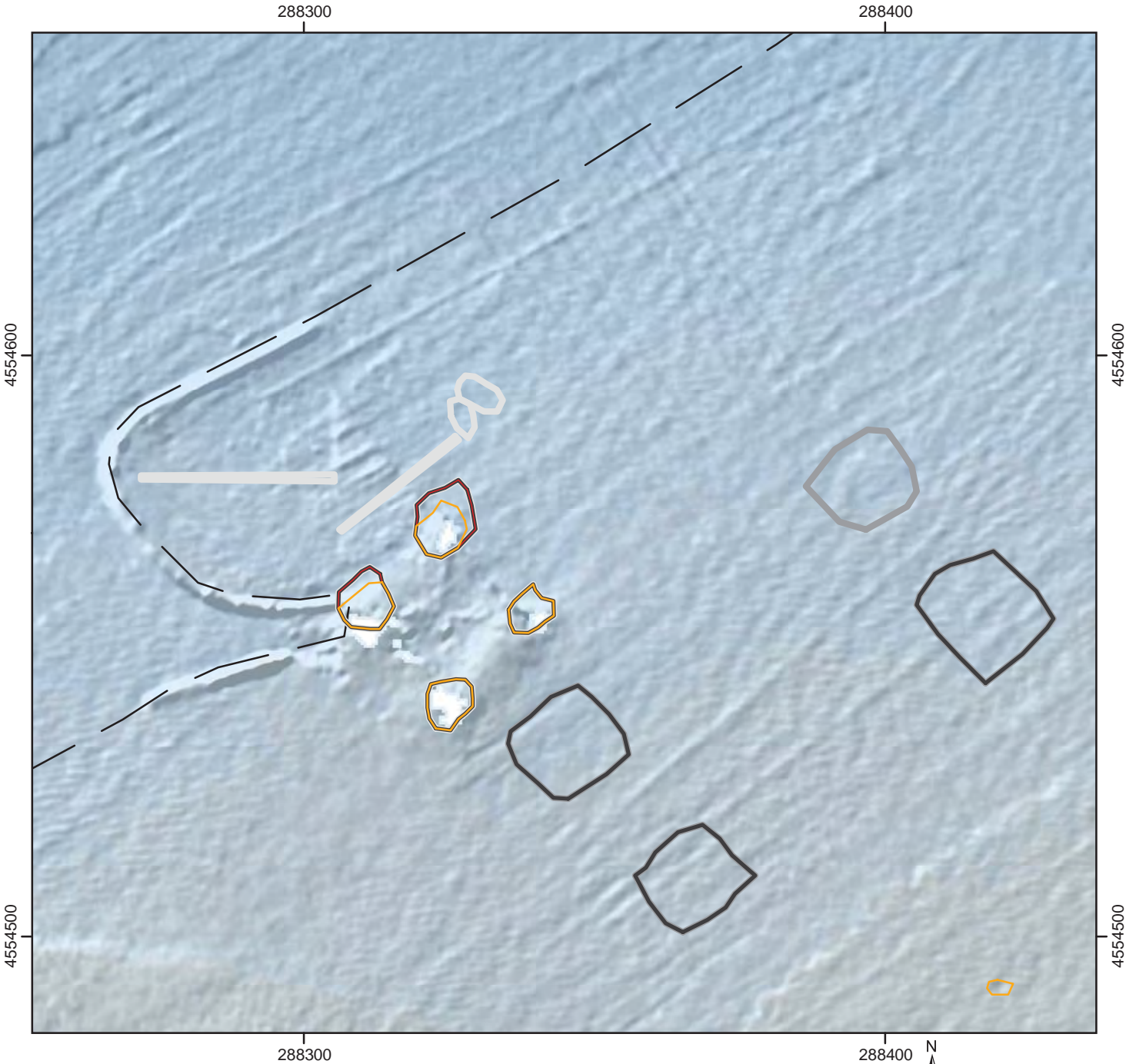

Legend

— Export Cable/Inter Array Cable

Interpreted Seafloor Disturbance Features

- Construction Season 1 (May 2016 Data)
- Construction Season 2 (Oct. 2016 Data)
- May 2017 Data
- Sep. 2018 Data
- Oct. 2017 Data

September 2018 Fugro Bathymetry (Meter, MLLW)

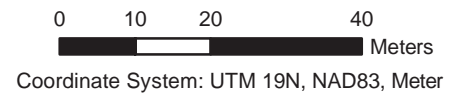
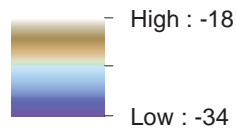

**SEAFLOOR DISTURBANCE PER SURVEY
WIND TURBINE GENERATOR NO. 3**
Seafloor Monitoring Study
Block Island Wind Farm and Transmission Project
Offshore Rhode Island

N:\Projects\04_2015\04_8115_0001_BOEM_RODEO\BlockIsland_RIO\outputs\Post_Con_Survey_5\MXD\Fig-5c_WTGS3_Bathymetry_with_Interp.mxd, 1/11/2019, T.Weathers

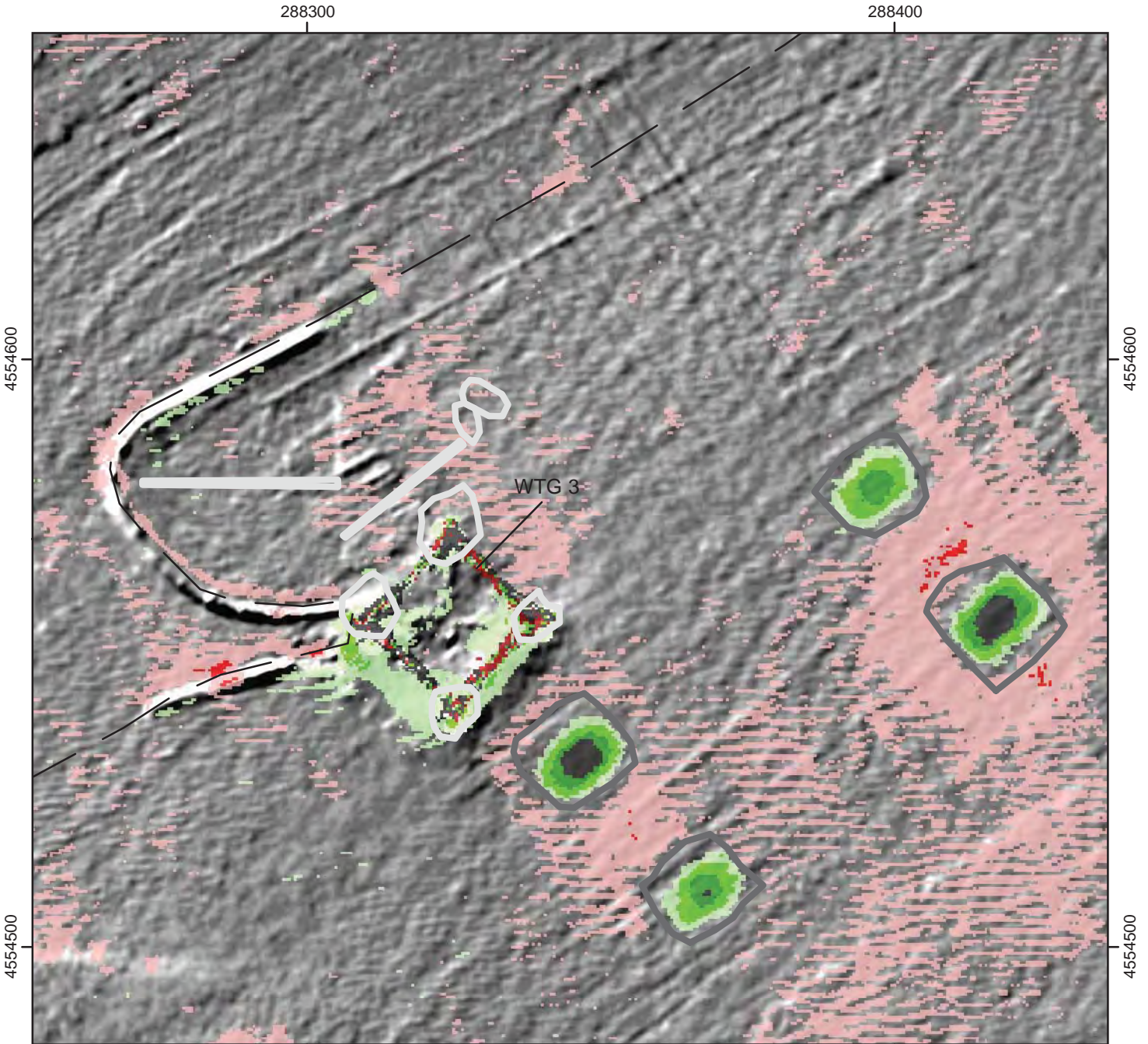

Legend

Difference between Survey 2 and 4 (meters)

- | | | |
|----------------------|--|--|
| Accretion | | More than 0.75 |
| | | 0.75 to 0.5 |
| | | 0.5 to 0.25 |
| | | 0.25 to 0.1 |
| | | -0.1 to 0.1 (No notable change in elevation) |
| Lowering/
Erosion | | -0.1 to -0.25 |
| | | -0.25 to -0.5 |
| | | -0.5 to -0.75 |
| | | More than -0.75 |

Export Cable/Inter Array Cable

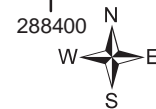

0 10 20 40
Meters

Coordinate System: UTM 19N, NAD83, Meter

**BATHYMETRY DIFFERENCES
WIND TURBINE GENERATOR NO. 3**
Seafloor Monitoring Study
Block Island Wind Farm and Transmission Project
Offshore Rhode Island

N:\Projects\04_2015\04_8115_0001_BOEM_RODEO\BlockIsland_RI\Outputs\Post_Con_Survey_5\MXD\Fig-5d_WTG3_Bathy_Differences.mxd, 8/23/2019, k.smith



N:\Projects\04_2015\04_8115_0001_BOEM_RODEO\BlockIsland_R1\Outputs\Post_Con_Survey_5\IMXD\Fig-6a_WTG4_Bathymetry_with_Contours.mxd, 1/1/2019, T.Weathers

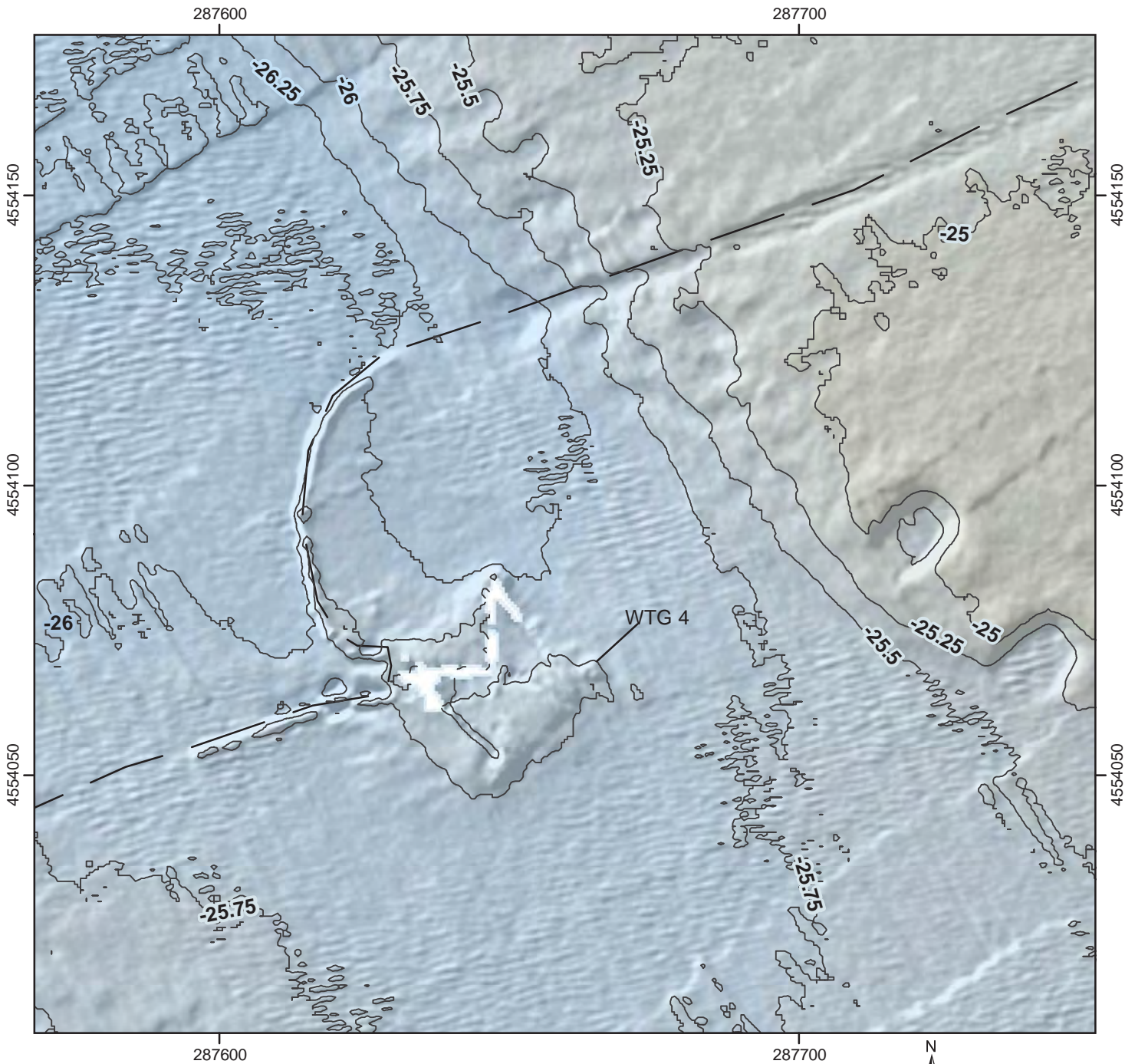

Legend

— Export Cable/Inter Array Cable

**September 2018 Fugro Bathymetry
(Meter, MLLW)**

High : -18



Low : -34

— Contour interval is 0.25 meters



0 10 20 40
Meters

Coordinate System: UTM 19N, NAD83, Meter

BATHYMETRY
WIND TURBINE GENERATOR NO. 4
Seafloor Monitoring Study
Block Island Wind Farm and Transmission Project
Offshore Rhode Island

N:\Projects\04_2015\04_8115_0001_BOEM_RODEO\BlockIsland_R\Outputs\Post_Con_Survey_5\IMXD\Fig-6b_WTG4_Bathymetry_with_Interp.mxd, 1/11/2019, T. Weathers

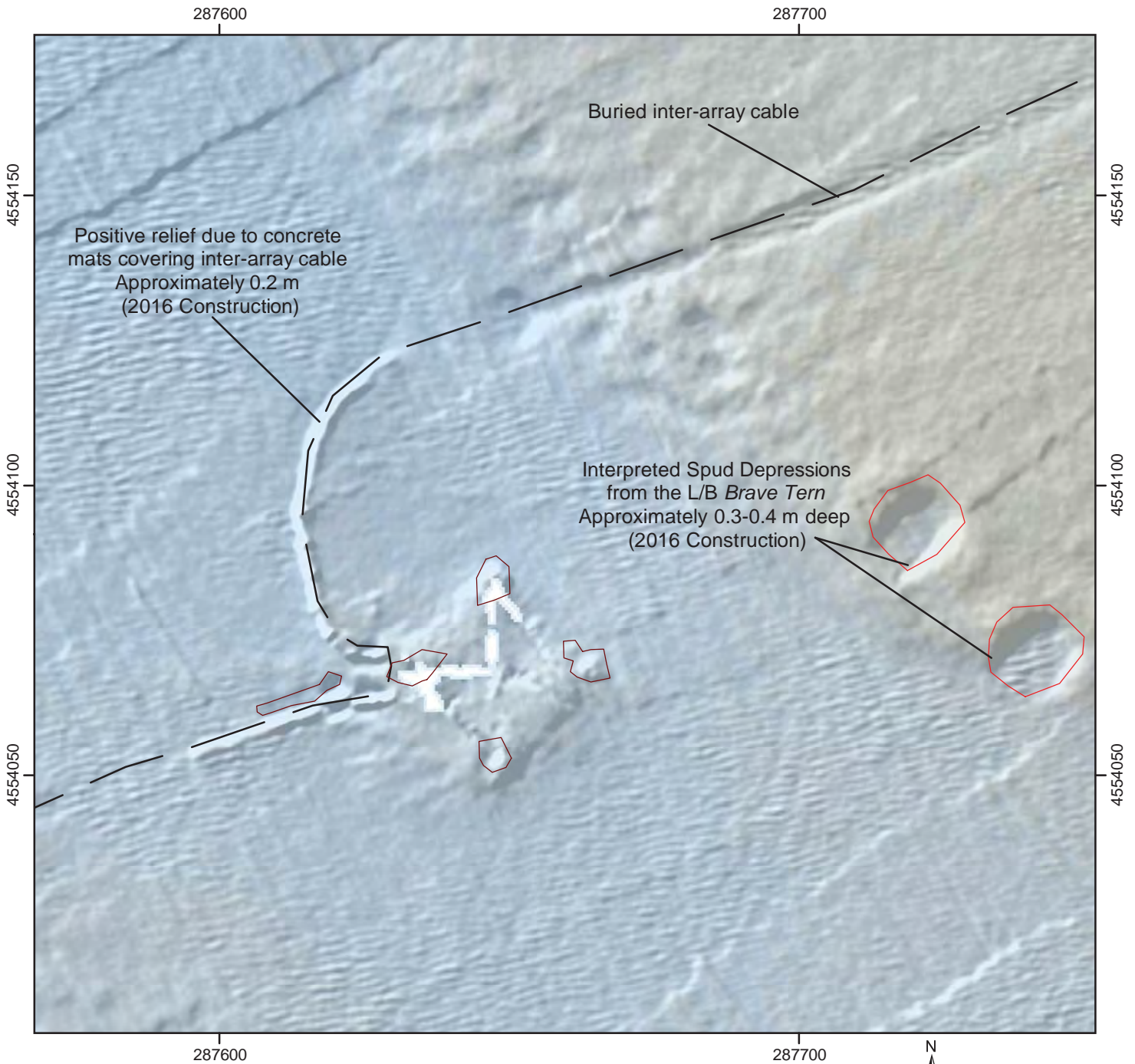

Legend

— Export Cable/Inter Array Cable

Interpreted Seafloor Disturbance Features

- Spud
- Scour

September 2018 Fugro Bathymetry (Meter, MLLW)

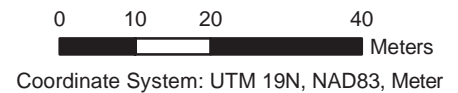
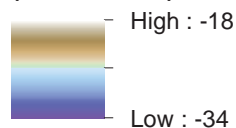

INTERPRETED SEAFLOOR DISTURBANCE TYPES
WIND TURBINE GENERATOR NO. 4
 Seafloor Monitoring Study
 Block Island Wind Farm and Transmission Project
 Offshore Rhode Island

N:\Projects\04_2015\04_8115_0001_BOEM_RODEO\BlockIsland_RIVOutputs\Post_Con_Survey_5MXXD\Fig-6c_WTC4_Bathymetry_with_Interp.mxd, 1/11/2019, T.Weathers

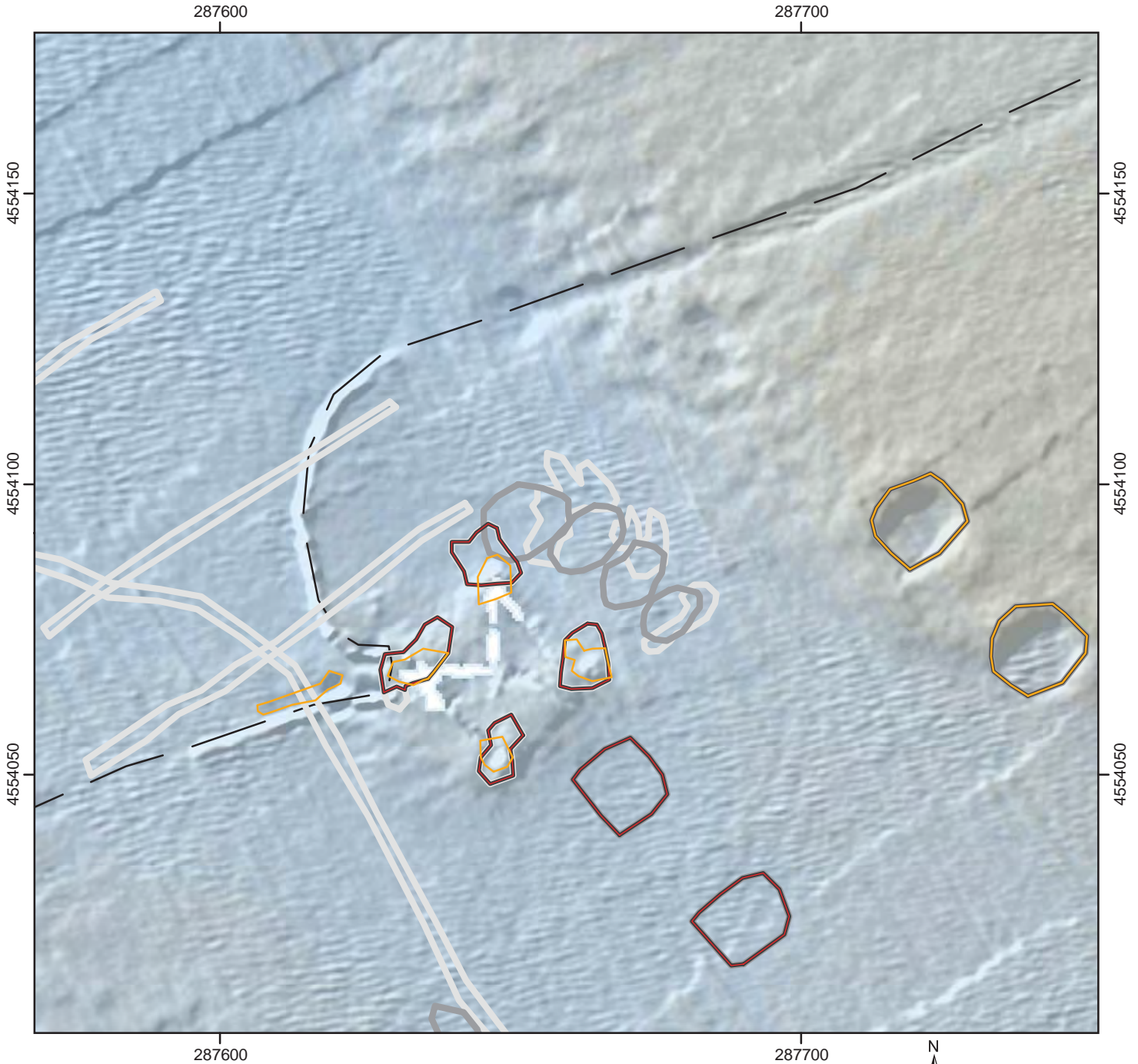

Legend

— Export Cable/Inter Array Cable

Interpreted Seafloor Disturbance Features

- Construction Season 1 (May 2016 Data)
- Construction Season 2 (Oct. 2016 Data)
- May 2017 Data
- Oct. 2017 Data
- Sep. 2018 Data

September 2018 Fugro Bathymetry (Meter, MLLW)

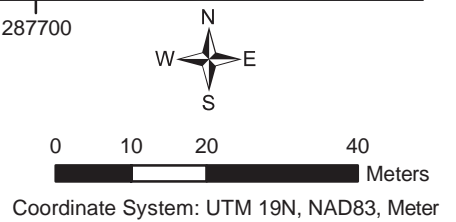
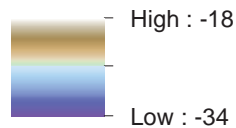

SEAFLOOR DISTURBANCE PER SURVEY
WIND TURBINE GENERATOR NO. 4
 Seafloor Monitoring Study
 Block Island Wind Farm and Transmission Project
 Offshore Rhode Island

N:\Projects\04_2015\04_8115_0001_BOEM_RODEO\BlockIsland_RI\Outputs\Post_Con_Survey_5\MXD\Fig-6d_WTG4_Bathy_Differences.mxd, 8/23/2019, k.smith

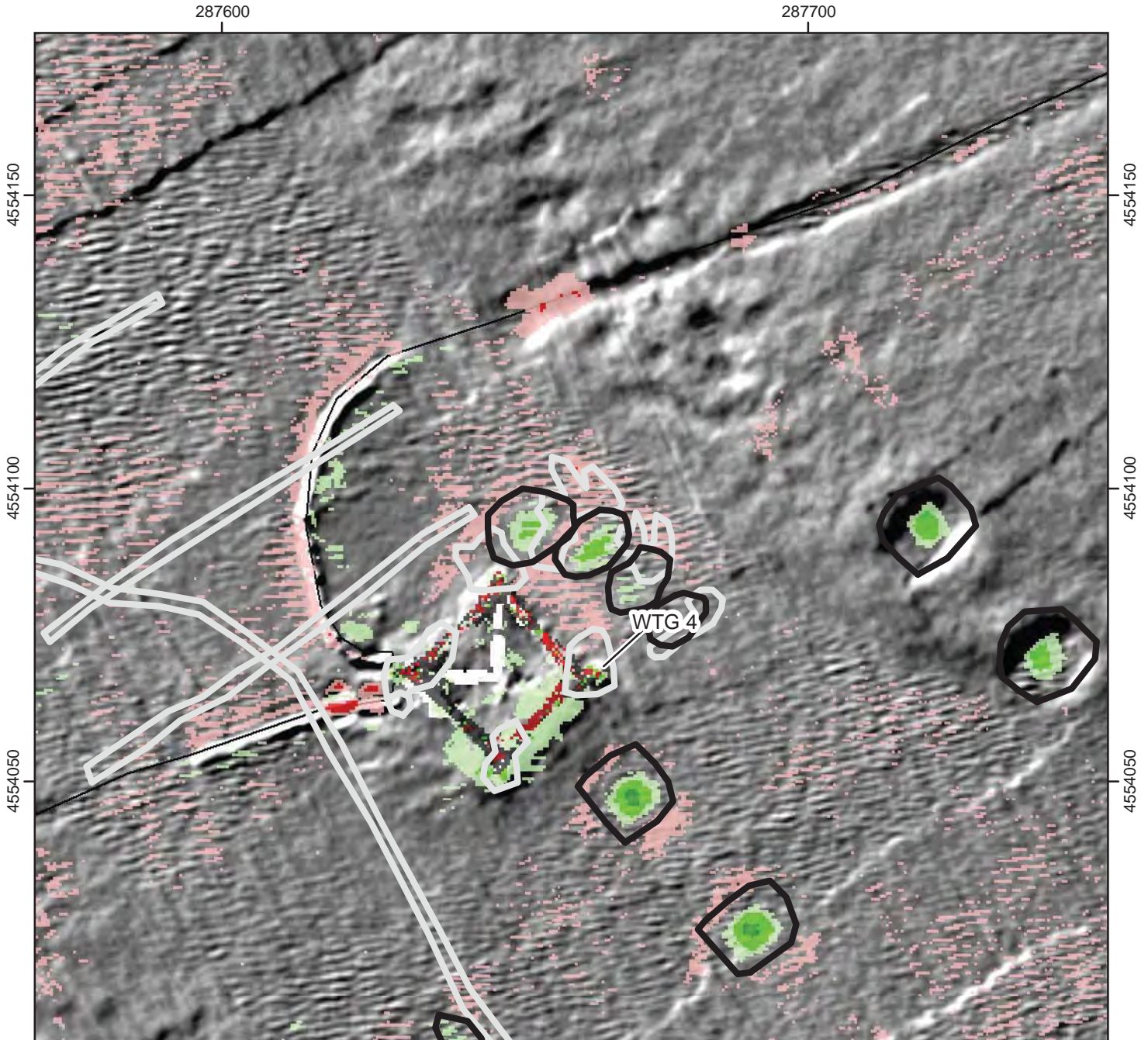

Legend

Difference between Survey 2 and 4 (meters)

- | | |
|---|---|
| <p>Accretion</p> <ul style="list-style-type: none"> More than 0.75 0.75 to 0.5 0.5 to 0.25 0.25 to 0.1 -0.1 to 0.1 (No notable change in elevation) <p>Lowering/
Erosion</p> <ul style="list-style-type: none"> -0.1 to -0.25 -0.25 to -0.5 -0.5 to -0.75 More tha -0.75 | <p>— Export Cable/Inter Array Cable</p> |
|---|---|



Coordinate System: UTM 19N, NAD83, Meter

BATHYMETRY DIFFERENCES
WIND TURBINE GENERATOR NO. 4
 Seafloor Monitoring Study
 Block Island Wind Farm and Transmission Project
 Offshore Rhode Island

N:\Projects\04_2015\04_8115_0001_BOEM_RODEO\BlockIsland_RIO\Outputs\Post_Con_Survey_5\IMXD\Fig-7a_WTG5_Bathymetry_with_Contours.mxd, 1/1/2019, T.Weathers

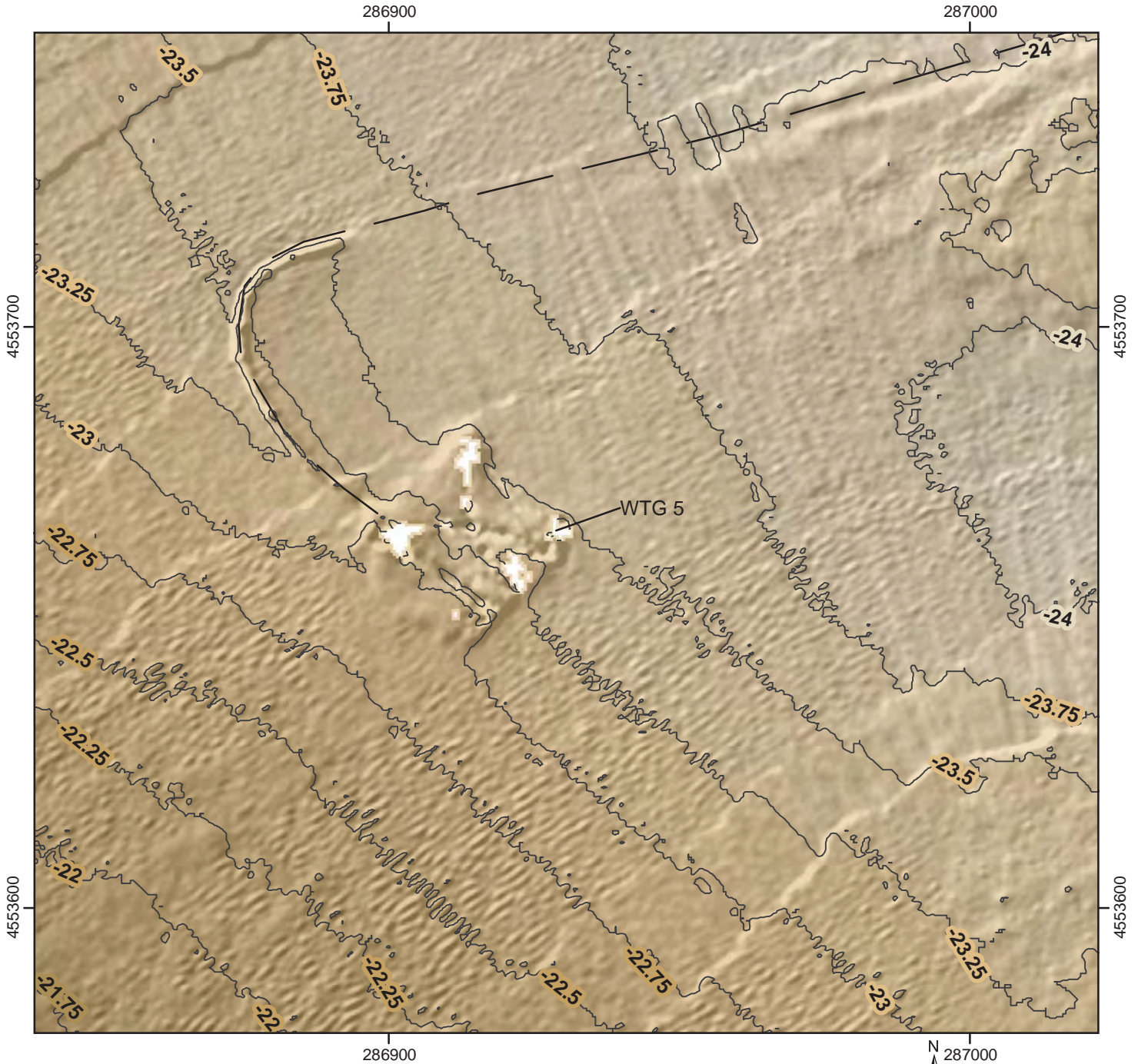

Legend

— Export Cable/Inter Array Cable

September 2018 Fugro Bathymetry (Meter, MLLW)

High : -18



Low : -34

— Contour interval is 0.25 meters



Coordinate System: UTM 19N, NAD83, Meter

BATHYMETRY
WIND TURBINE GENERATOR NO. 5
Seafloor Monitoring Study
Block Island Wind Farm and Transmission Project
Offshore Rhode Island

N:\Projects\04_2015\04_8115_0001_BOEM_RODEO\BlockIsland_RIVOutputs\Post_Con_Survey_51MXD\Fig-7b_WTGS_Bathymetry_with_Interp.mxd, 1/11/2019, T.Weathers



Legend

— Export Cable/Inter Array Cable

Interpreted Seafloor Disturbance Features

□ Scour

**September 2018 Fugro Bathymetry
(Meter, MLLW)**

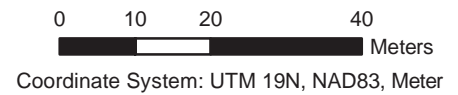
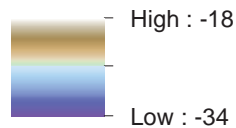

**INTERPRETED SEAFLOOR DISTURBANCE TYPES
WIND TURBINE GENERATOR NO. 5**
Seafloor Monitoring Study
Block Island Wind Farm and Transmission Project
Offshore Rhode Island

N:\Projects\04_2015\04_8115_0001_BOEM_RODEO\BlockIsland_RIVOutputs\Post_Con_Survey_5M\XD\Fig-7c_WT65_Bathymetry_with_Interp.mxd, 1/11/2019, T.Weathers



Legend

— Export Cable/Inter Array Cable

Interpreted Seafloor Disturbance Features

- Construction Season 1 (May 2016 Data)
- Construction Season 2 (Oct. 2016 Data)
- May 2017 Data Sep. 2018 Data
- Oct. 2017 Data

September 2018 Fugro Bathymetry (Meter, MLLW)

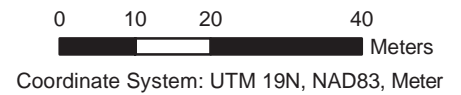
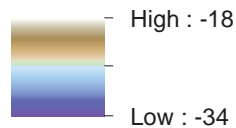

SEAFLOOR DISTURBANCE PER SURVEY
WIND TURBINE GENERATOR NO. 5
 Seafloor Monitoring Study
 Block Island Wind Farm and Transmission Project
 Offshore Rhode Island

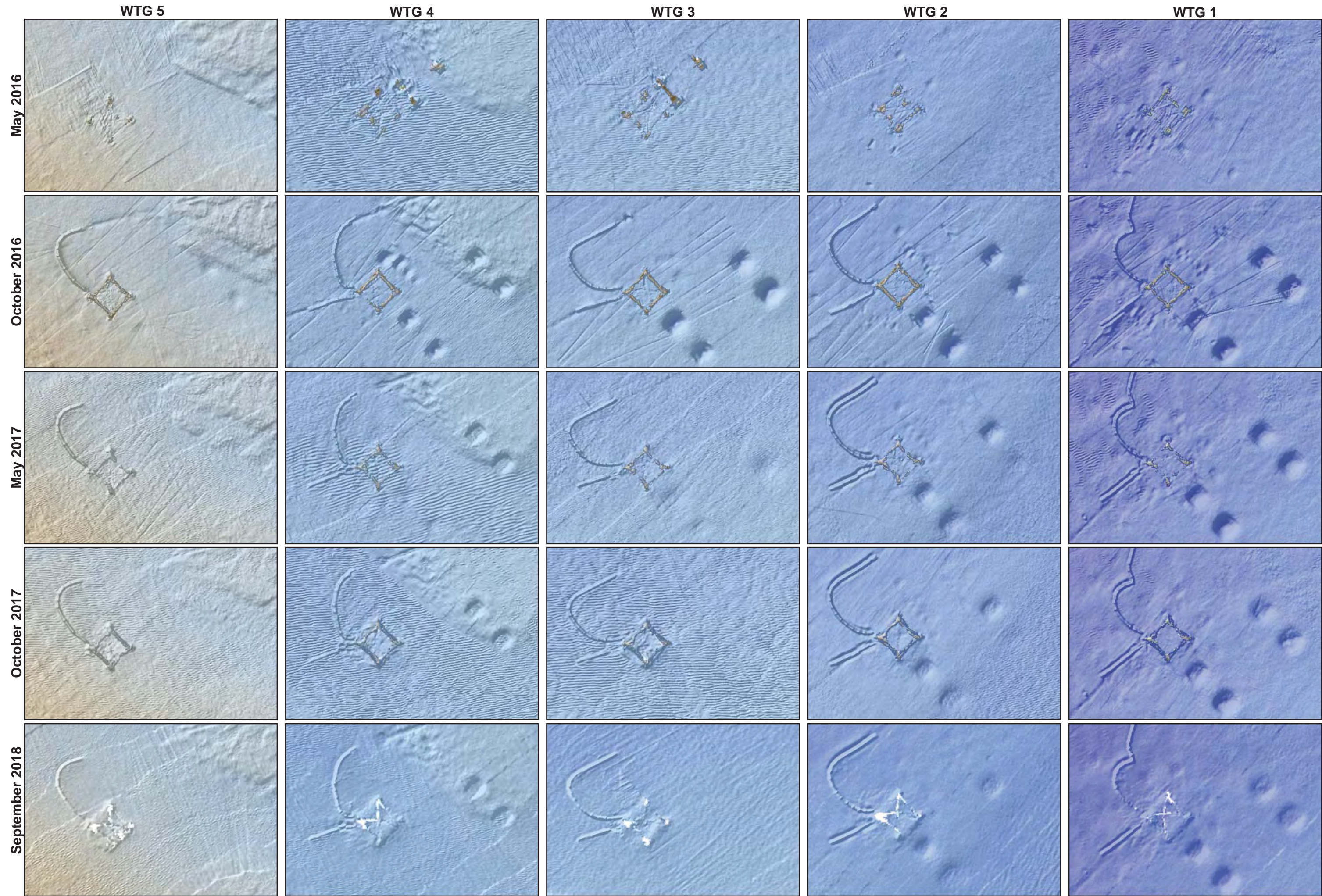

Legend

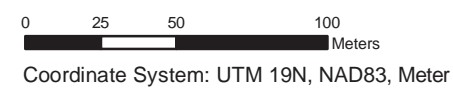

Fugro Bathymetry (Meter, MLLW)

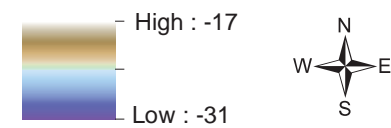

BATHYMETRY COMPARISON
Seafloor Monitoring Study
Block Island Wind Farm and Transmission Project
Offshore Rhode Island

N:\Projects\04_201504_8115_0001_BOEM_RODEO\BlockIsland_RV\Outputs\Post_Con_Survey_4M\XD\Fig-8_Time_Series_All.mxd_12/21/2018_T.Weathers

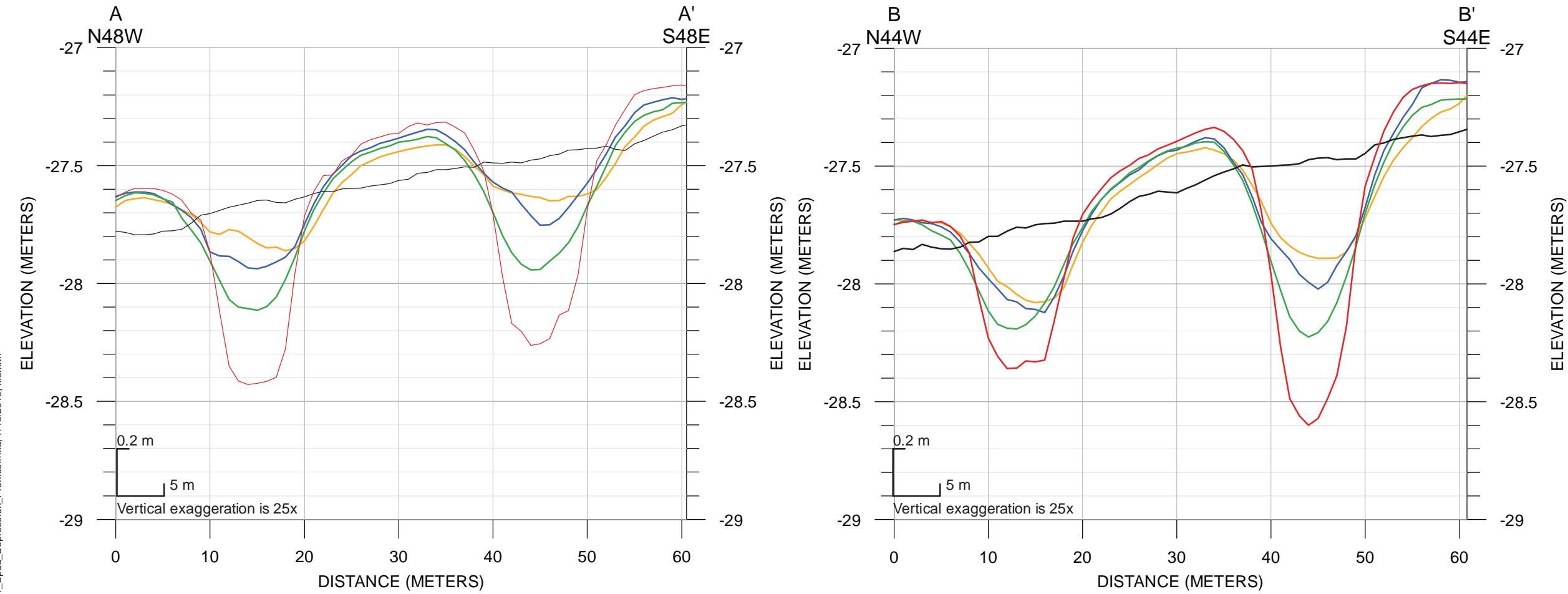

- Legend**
- Survey No. 1 (May 2016)
 - Survey No. 2 (October 2016)
 - Survey No. 3 (May 2017)
 - Survey No. 4 (October 2017)
 - Survey No. 5 (September 2018)

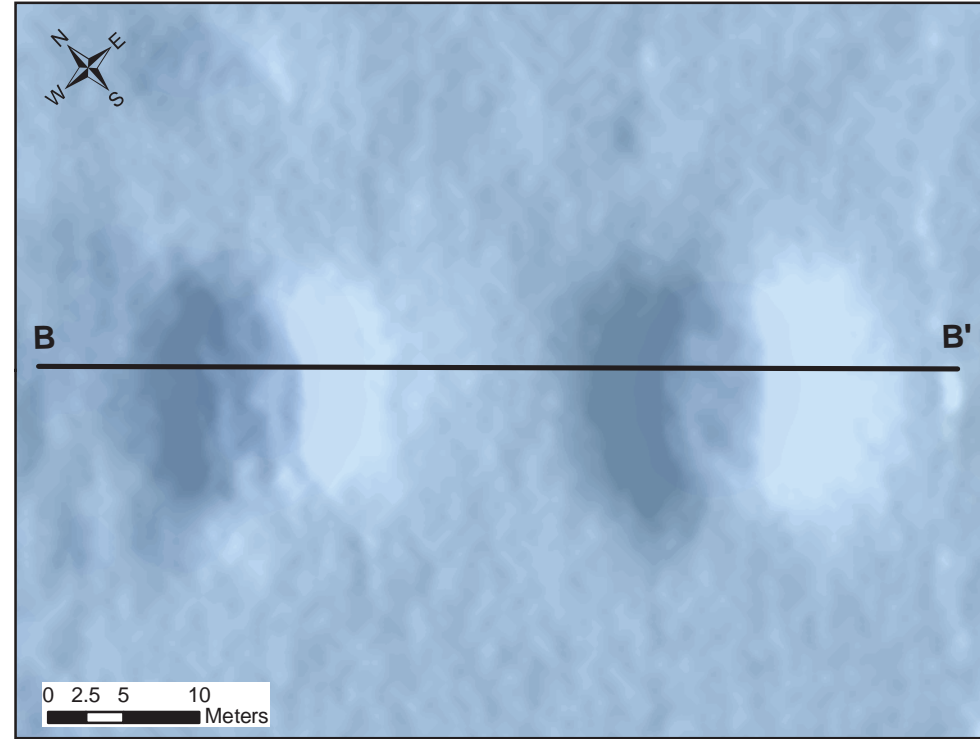
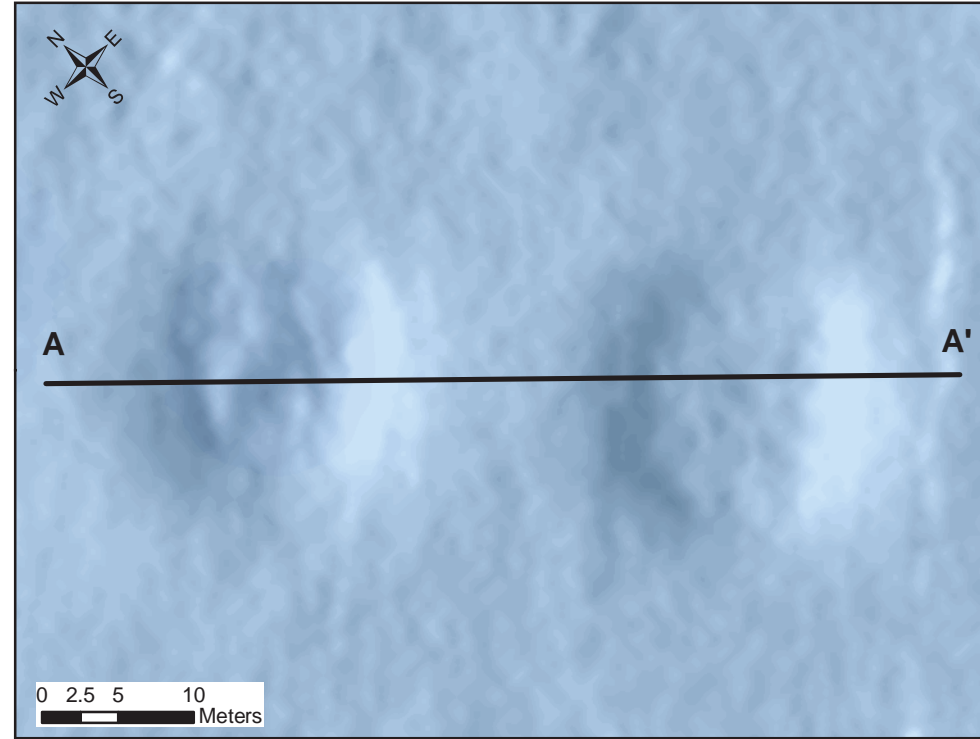
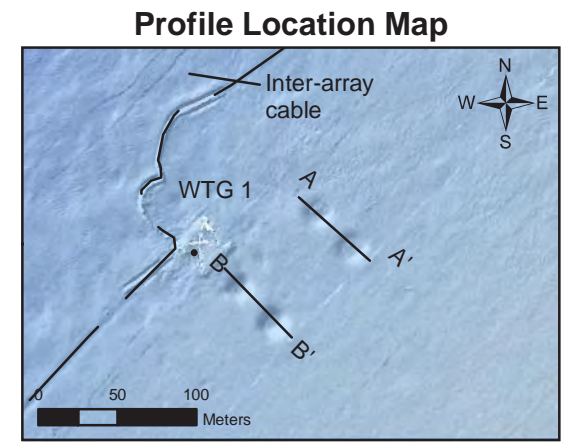

Notes:
The depressions shown in this figure were created by the L/B Brave Tern vessel while installing the wind turbine during Construction Season 2 that occurred in between Surveys 1 and 2. Bathymetry data shown in the plan views are from Survey 5.

**EXAMPLE OF SEAFLOOR RECOVERY
WIND TURBINE GENERATOR NO. 1**
Seafloor Monitoring Study
Block Island Wind Farm and Transmission Project
Offshore Rhode Island

N:\Projects\04_201504_8115_0001_BOEM_BLOCKISLAND_R1\Outputs\Post_Con_Survey_5\WXD\Fig-9_WTG1_Spud_Depression_Profiles.mxd, 7/15/2019, k.smith

Legend

- Survey No. 1 (May 2016)
- Survey No. 2 (October 2016)
- Survey No. 3 (May 2017)
- Survey No. 4 (October 2017)
- Survey No. 5 (September 2018)

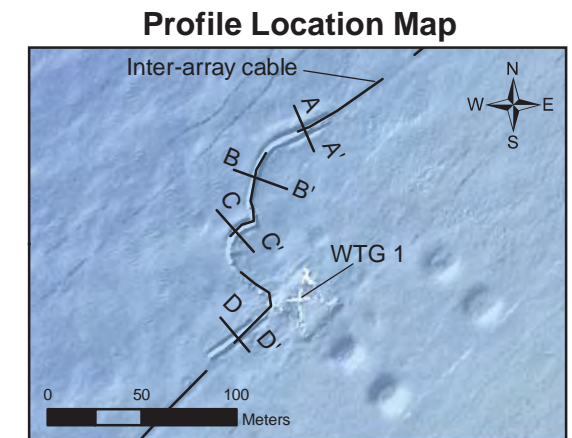
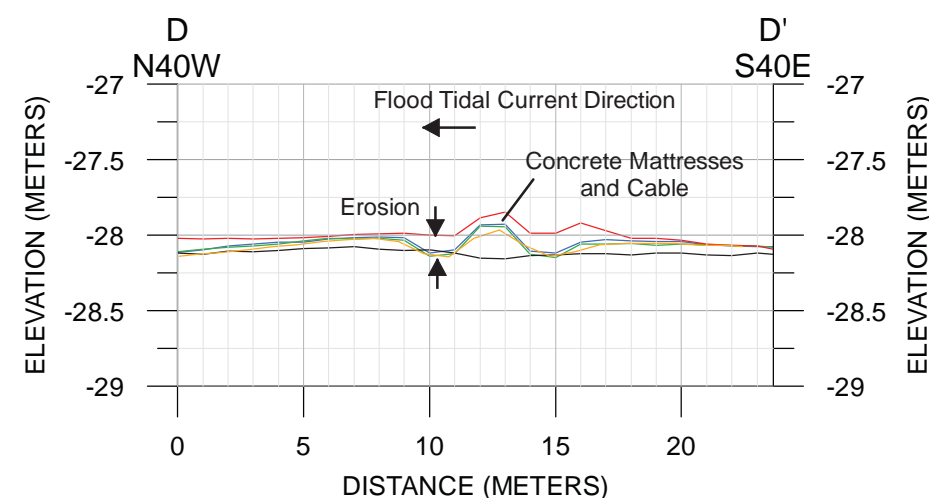
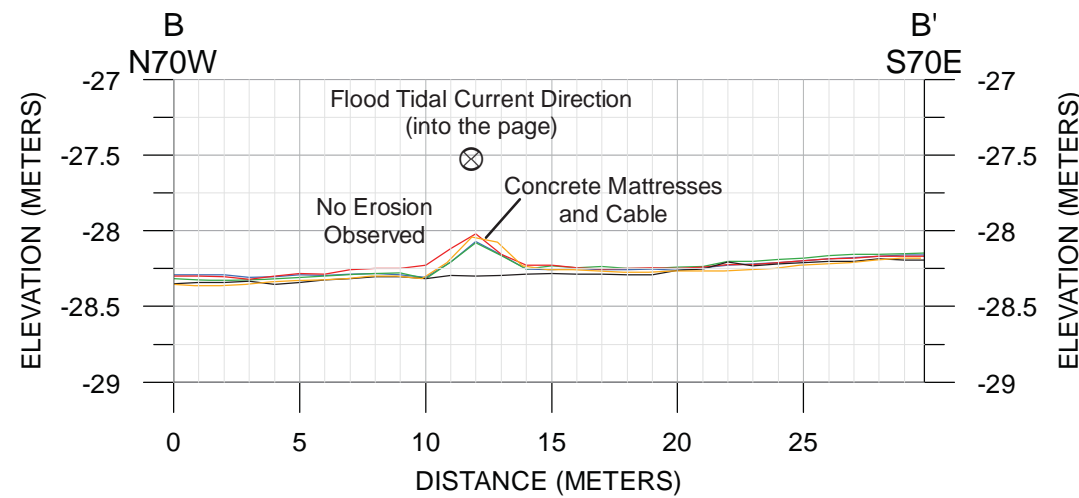
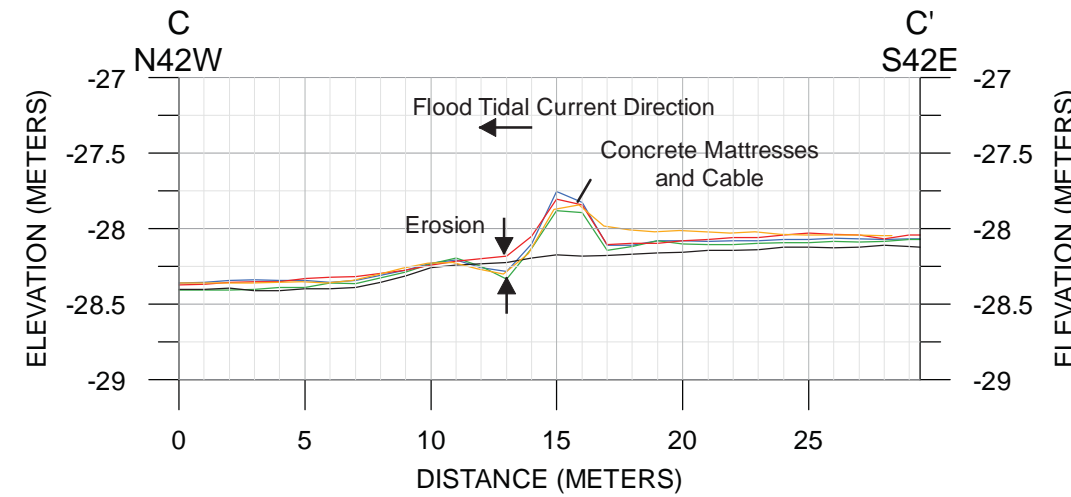
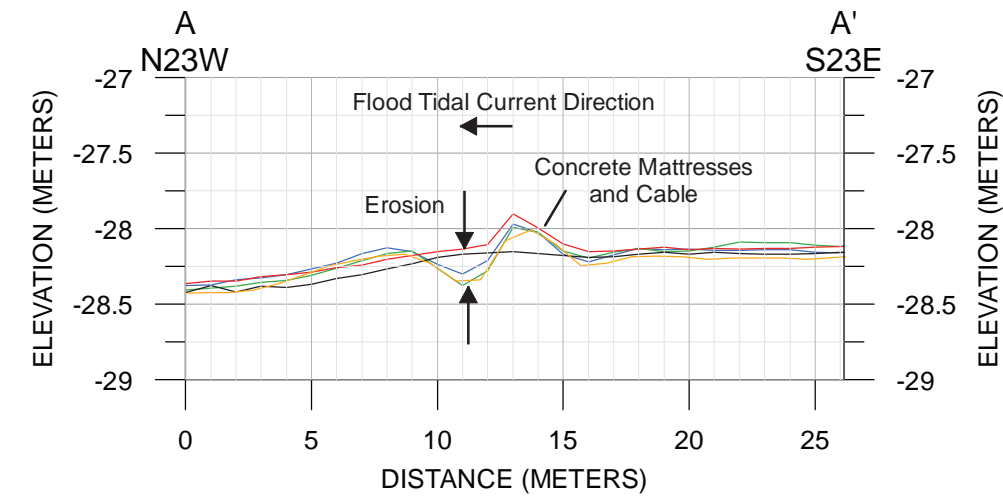

Notes:

Survey 1 was conducted before the cable and concrete mattresses were installed.

Principle tidal axis is aligned in the NNW-SSE direction. Cable segment in Profile B is nearly aligned with the principle tidal axis and shows the least amount of scour. Cable segments shown in Profiles A, C, and D are oriented perpendicular to the principle tidal axis. Scour is most prevalent on the northern side of the cable/concrete mattresses which indicates the dominant tidal current flow at this location is likely to the NNW (flood tidal current direction).

**EXAMPLE OF SEAFLOOR RECOVERY
WIND TURBINE GENERATOR NO. 1**
Seafloor Monitoring Study
Block Island Wind Farm and Transmission Project
Offshore Rhode Island

N:\Projects\04_201504_8115_0001_BOEM_RODEO\BlocksIsland_R1\Outputs\Post_Con_Survey_5M\XD\Fig-9_WTG1_Spud_Depression_Profiles.mxd, 7/15/2019, k.smith

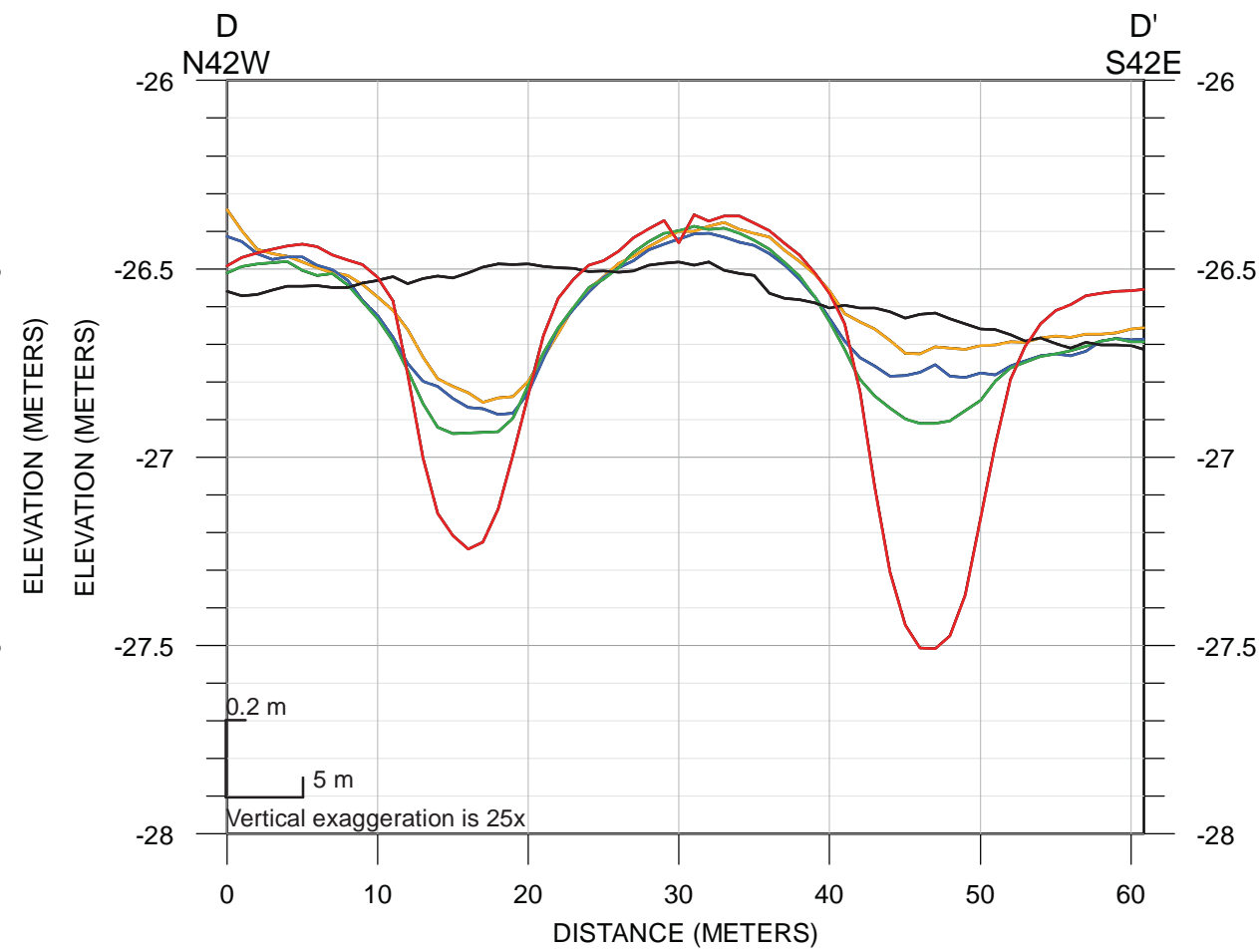
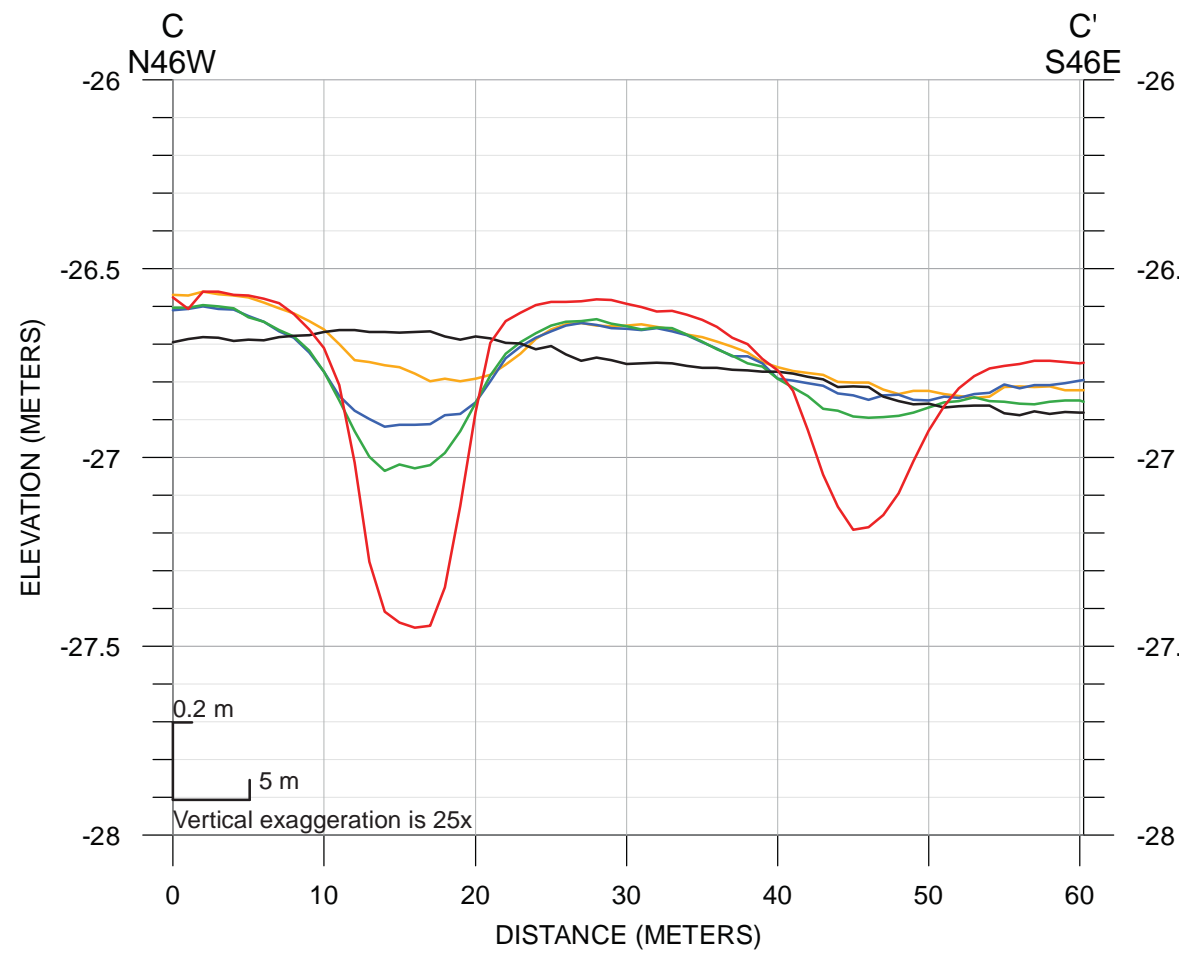

Legend

- Survey No. 1 (May 2016)
- Survey No. 2 (October 2016)
- Survey No. 3 (May 2017)
- Survey No. 4 (October 2017)
- Survey No. 5 (September 2018)

Profile Location Map

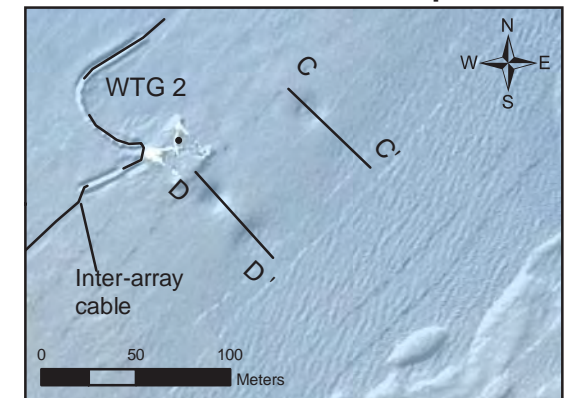

Notes:

The depressions shown in this figure were created by the L/B Brave Tern vessel while installing the wind turbine during Construction Season 2 that occurred in between Surveys 1 and 2. Bathymetry data shown in the plan views are from Survey 5.

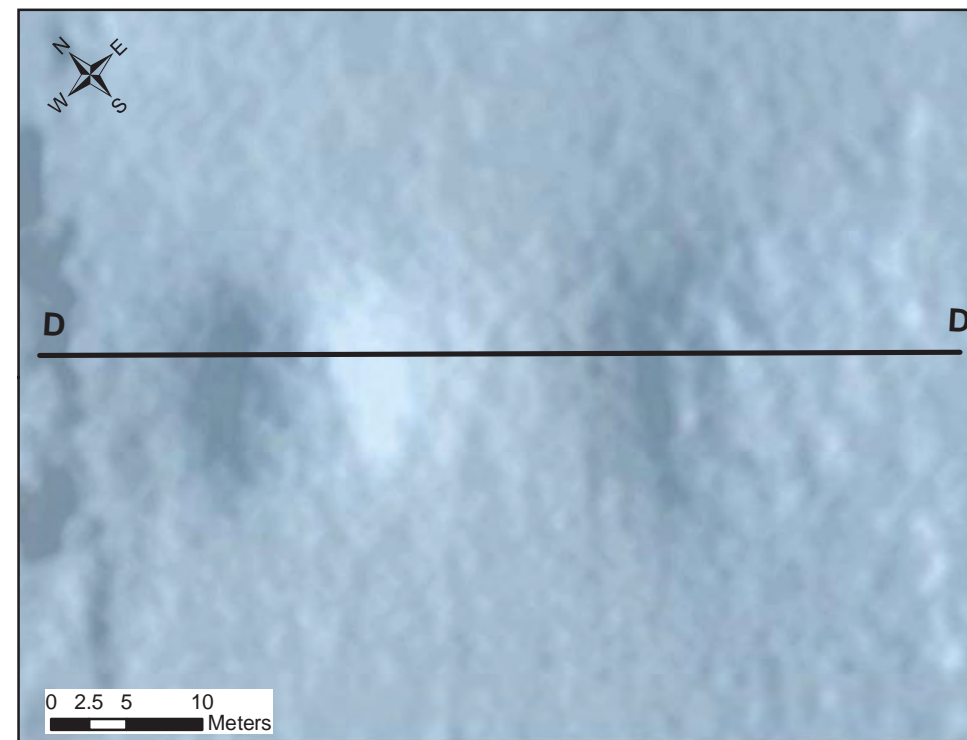
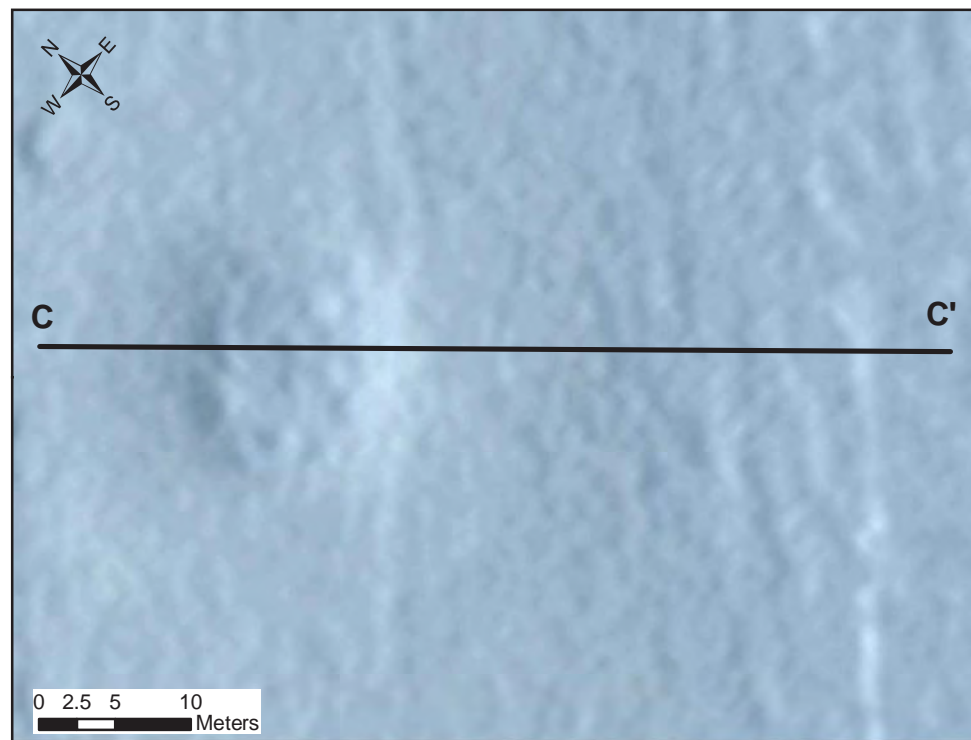

**EXAMPLE OF SEAFLOOR RECOVERY
WIND TURBINE GENERATOR NO. 2**
Seafloor Monitoring Study
Block Island Wind Farm and Transmission Project
Offshore Rhode Island

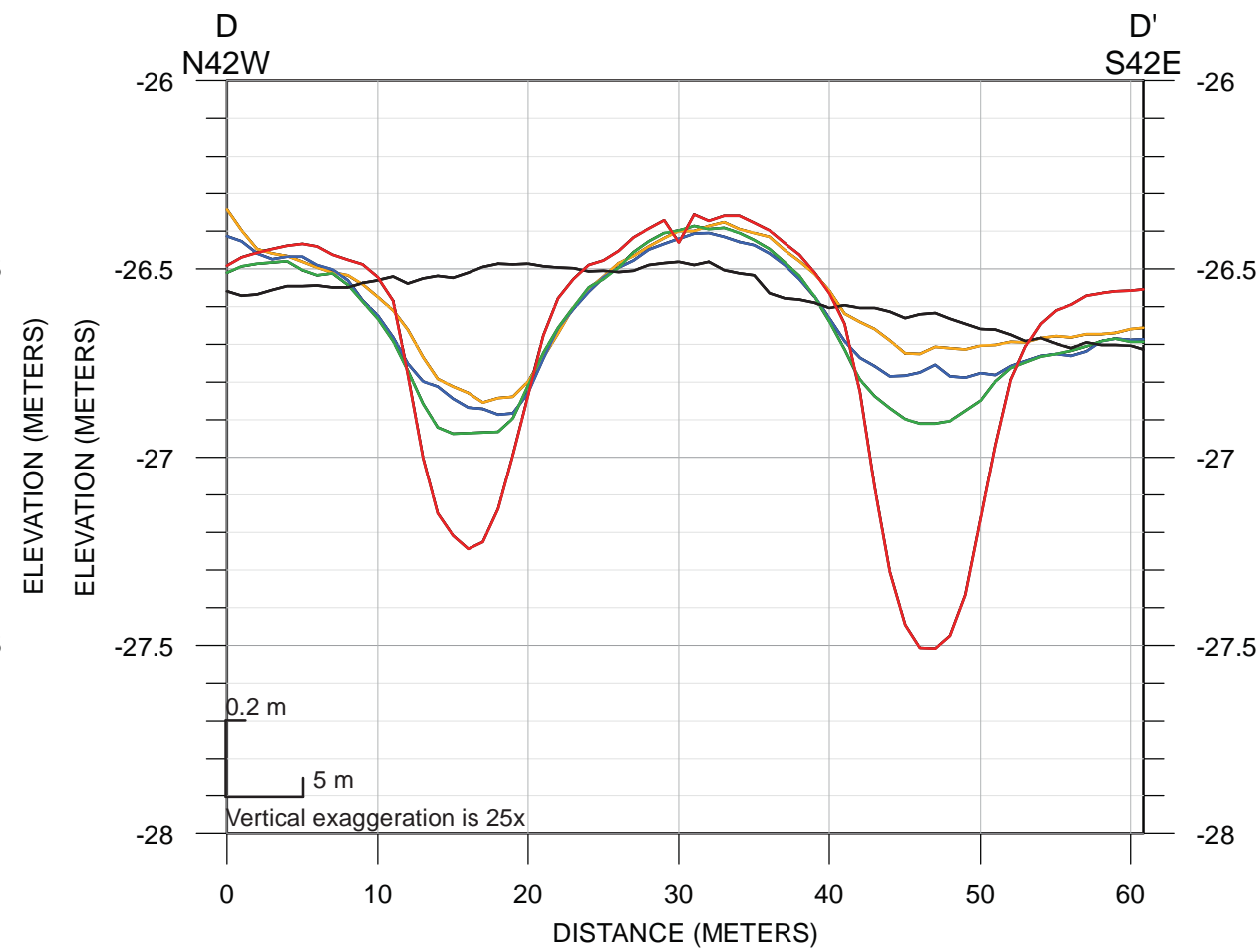
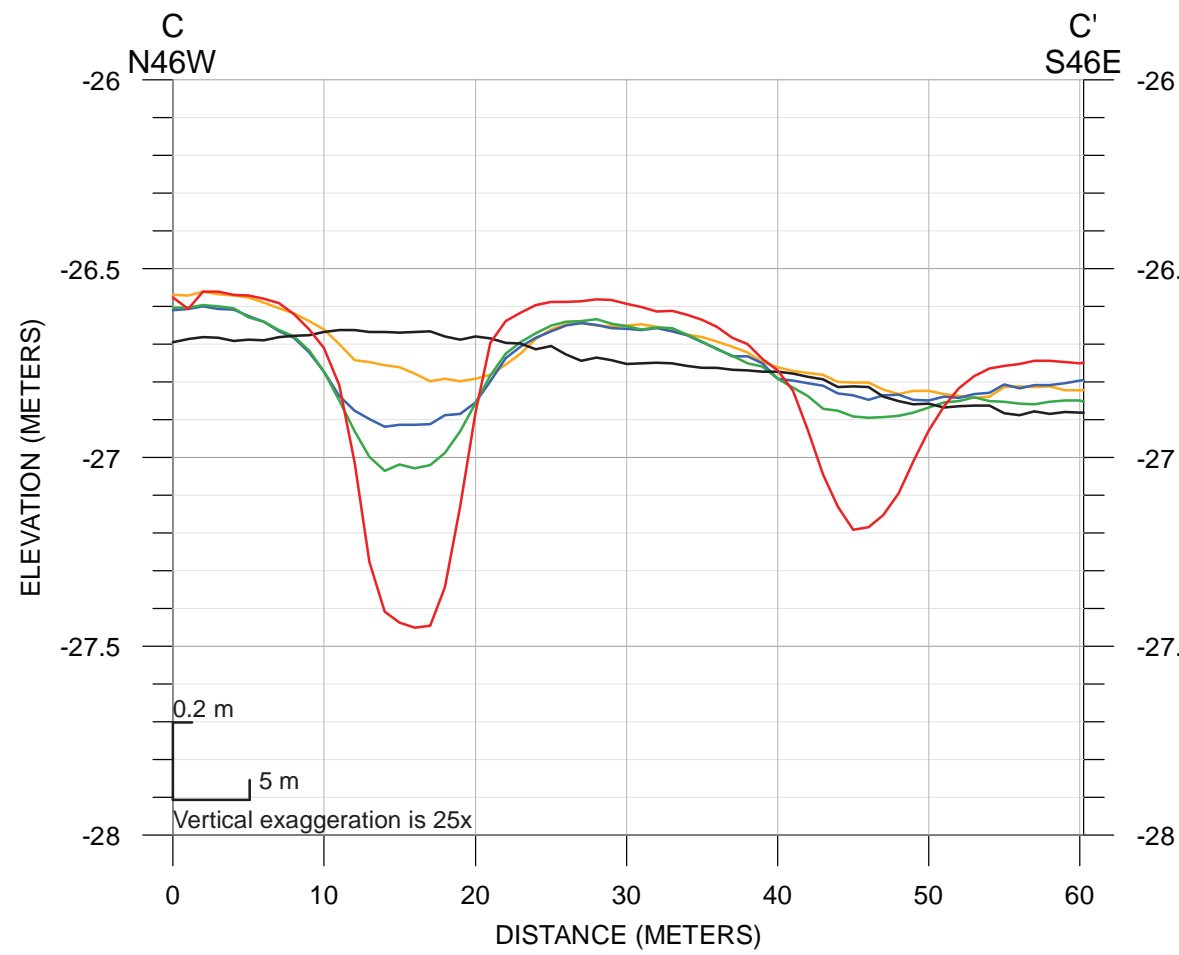

Legend

- Survey No. 1 (May 2016)
- Survey No. 2 (October 2016)
- Survey No. 3 (May 2017)
- Survey No. 4 (October 2017)
- Survey No. 5 (September 2018)

Profile Location Map

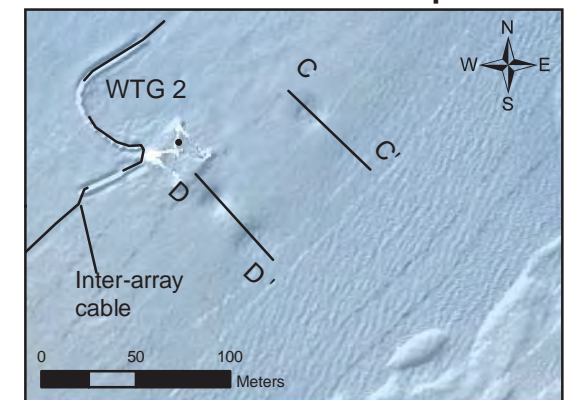

Notes:

The depressions shown in this figure were created by the L/B Brave Tern vessel while installing the wind turbine during Construction Season 2 that occurred in between Surveys 1 and 2. Bathymetry data shown in the plan views are from Survey 5.

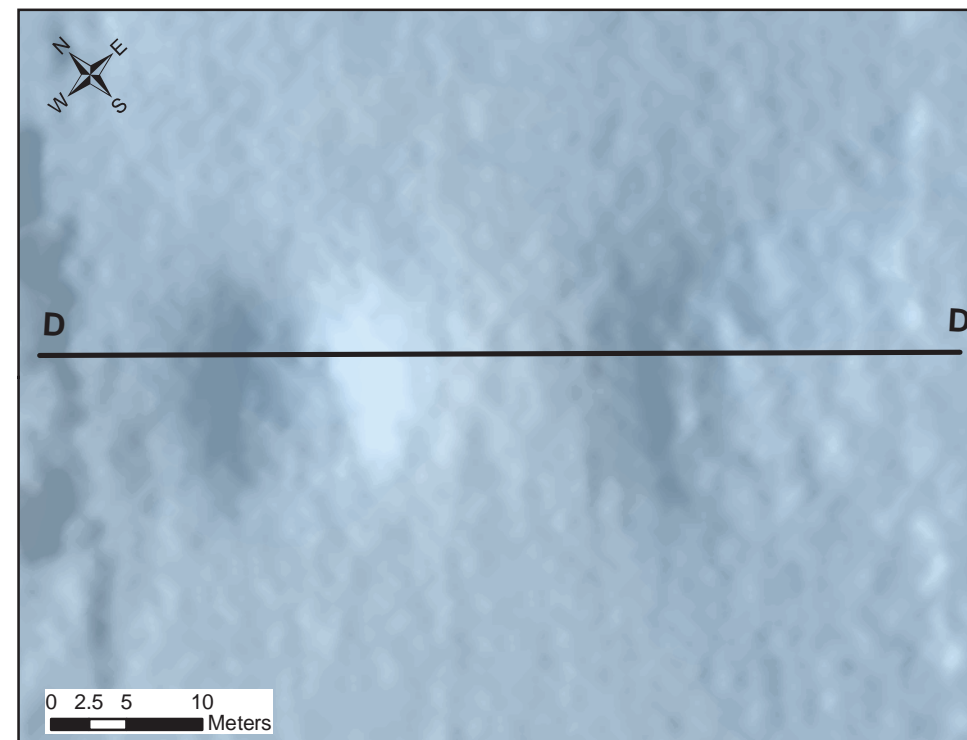
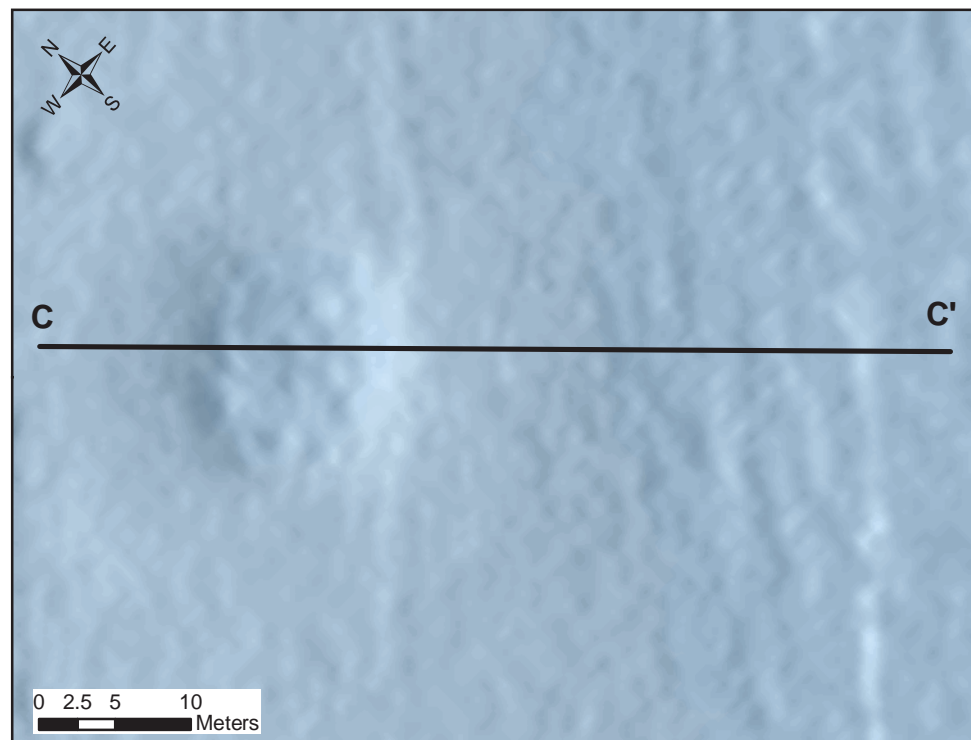

**EXAMPLE OF SEAFLOOR RECOVERY
WIND TURBINE GENERATOR NO. 2**
Seafloor Monitoring Study
Block Island Wind Farm and Transmission Project
Offshore Rhode Island

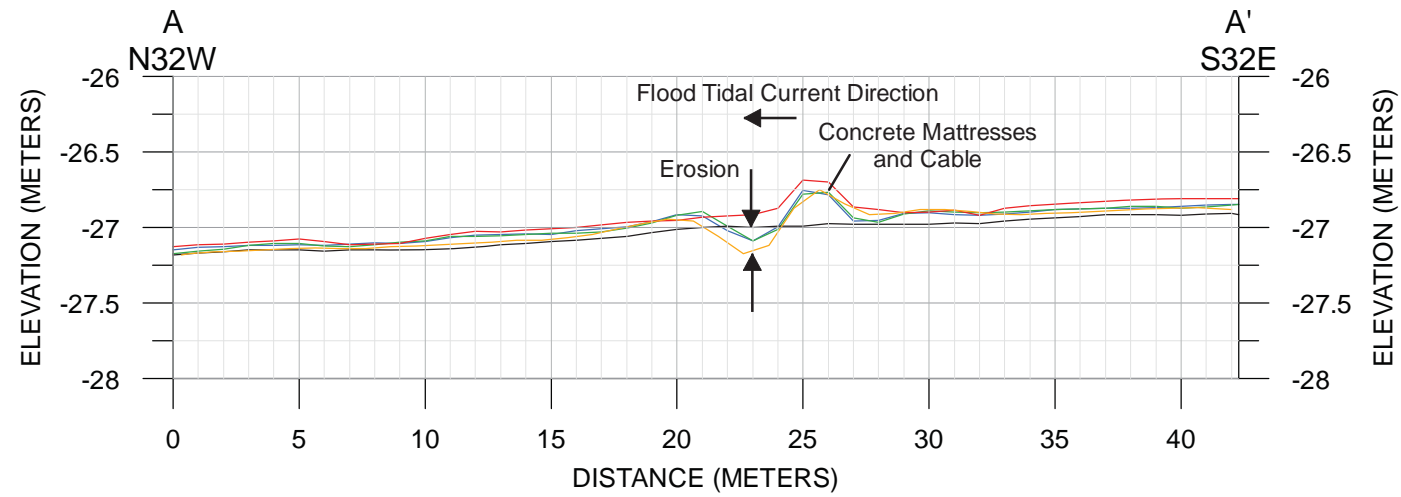

0.5 m
3 m
Vertical exaggeration is 6x.

Legend

- Survey No. 1 (May 2016)
- Survey No. 2 (October 2016)
- Survey No. 3 (May 2017)
- Survey No. 4 (October 2017)
- Survey No. 5 (September 2018)

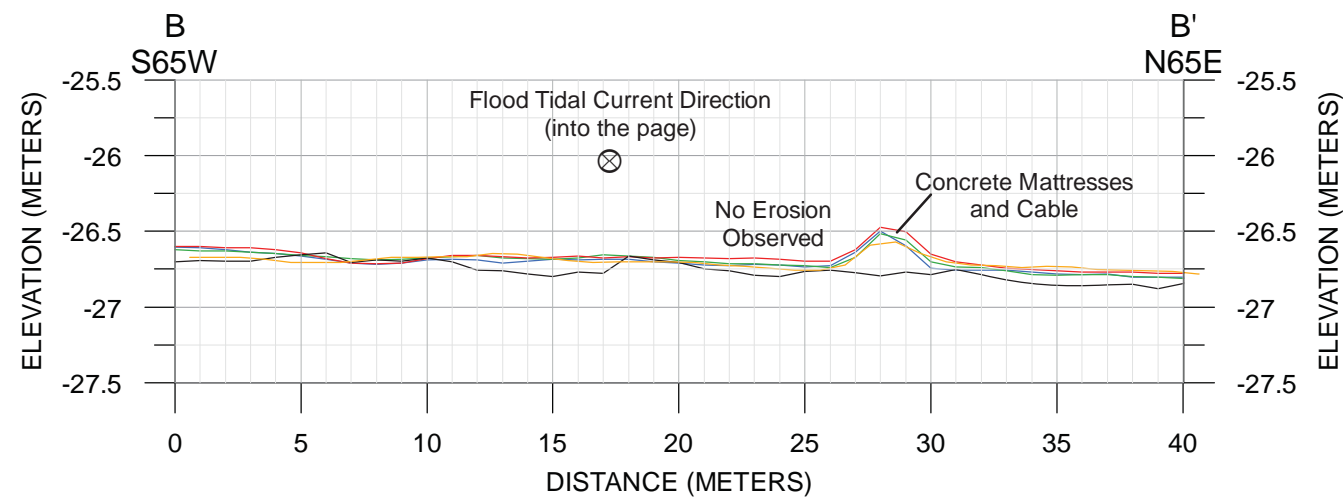

0.5 m
3 m
Vertical exaggeration is 6x.

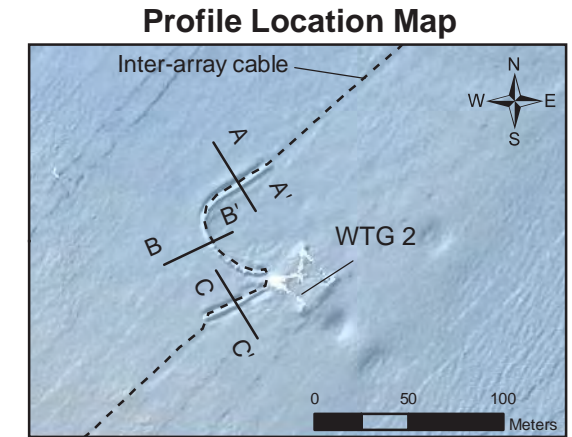

Notes:

Survey 1 was conducted before the cable and concrete mattresses were installed.

Principle tidal axis is aligned in the NNW-SSE direction. Cable segment in Profile B is nearly aligned with the principle tidal axis and shows the least amount of scour. Cable segments shown in Profiles A and D are oriented perpendicular to the principle tidal axis. Scour is most prevalent on the northern side of the cable/concrete mattresses which indicates the dominant tidal current flow at this location is likely to the NNW (flood tidal current direction).

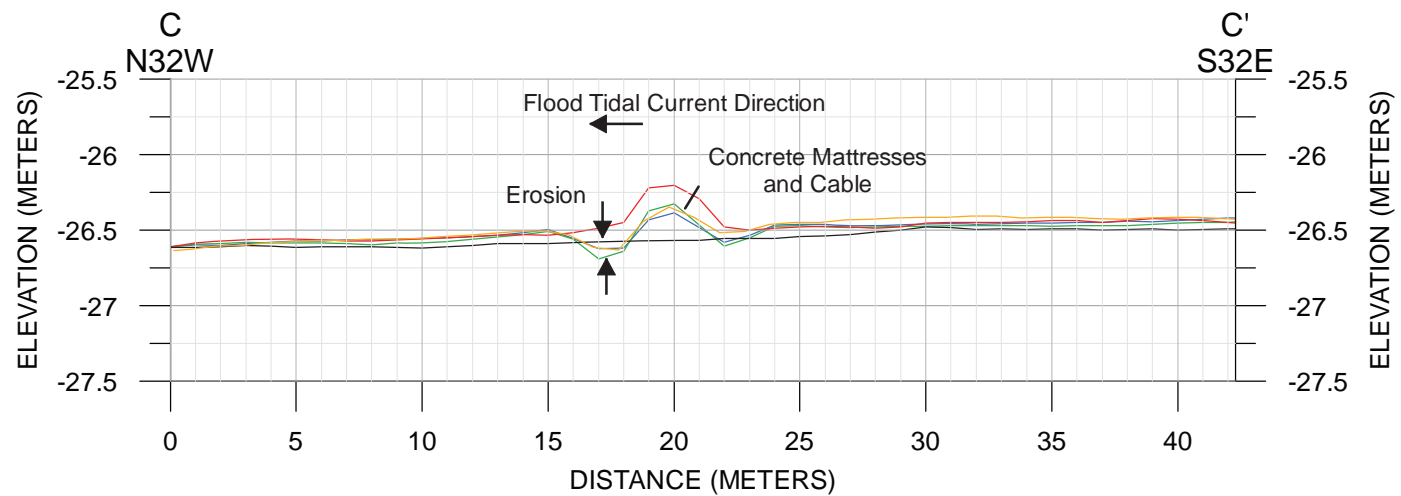

0.5 m
3 m
Vertical exaggeration is 6x.

**EXAMPLE OF SEAFLOOR RECOVERY
WIND TURBINE GENERATOR NO. 2**
Seafloor Monitoring Study
Block Island Wind Farm and Transmission Project
Offshore Rhode Island

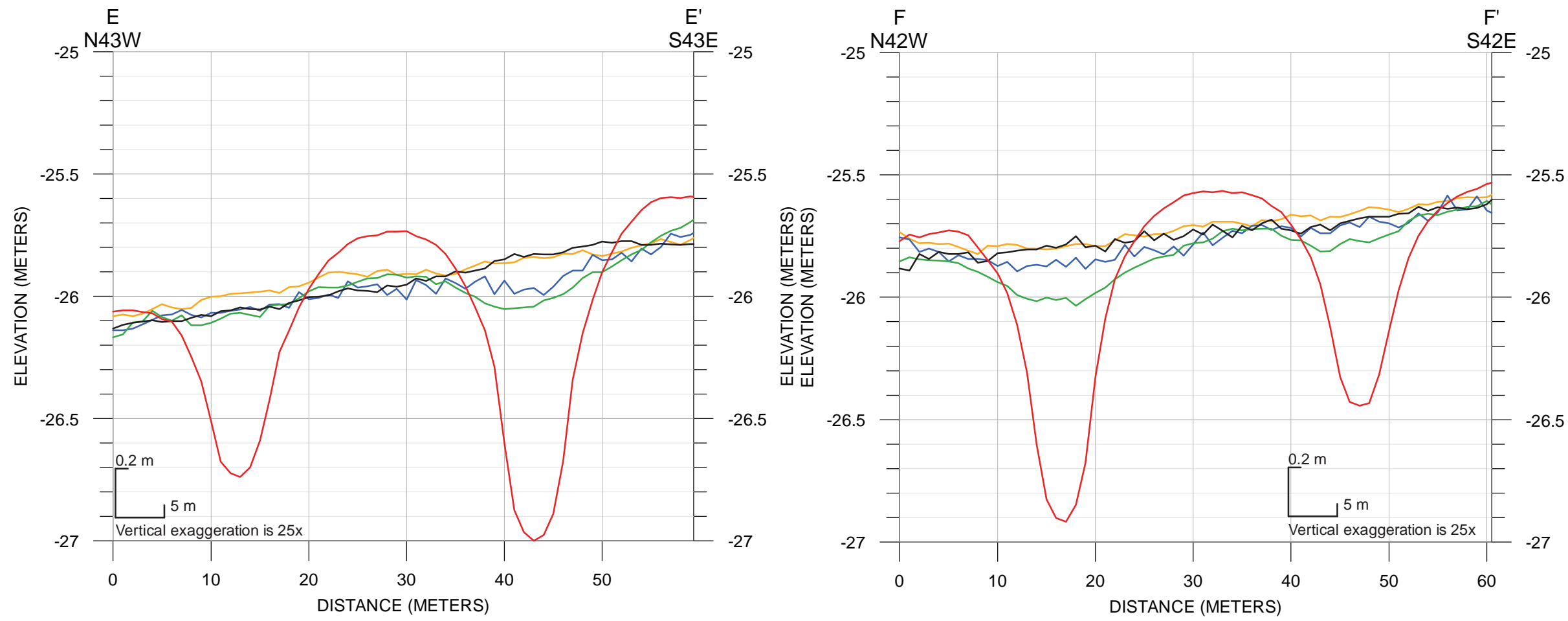

Legend

- Survey No. 1 (May 2016)
- Survey No. 2 (October 2016)
- Survey No. 3 (May 2017)
- Survey No. 4 (October 2017)
- Survey No. 5 (September 2018)

Profile Location Map

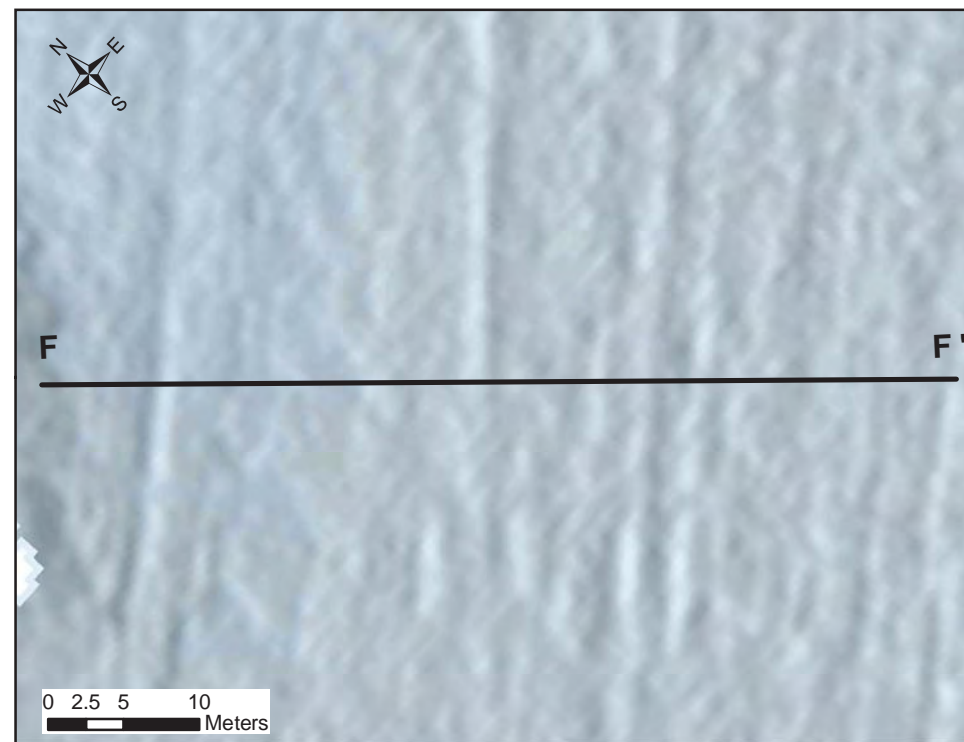
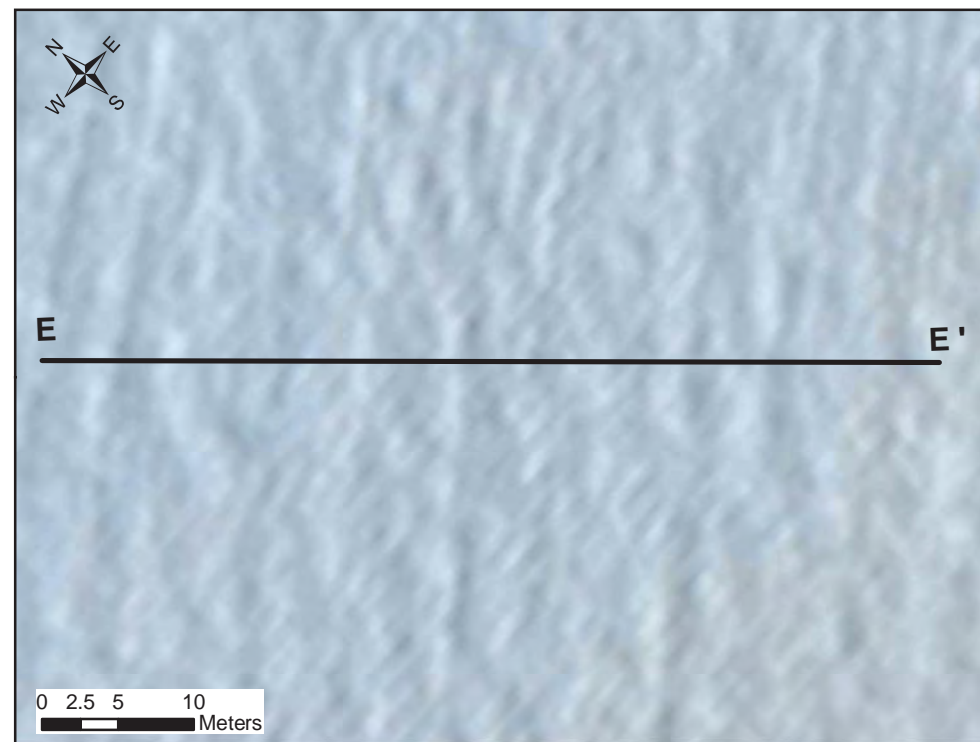
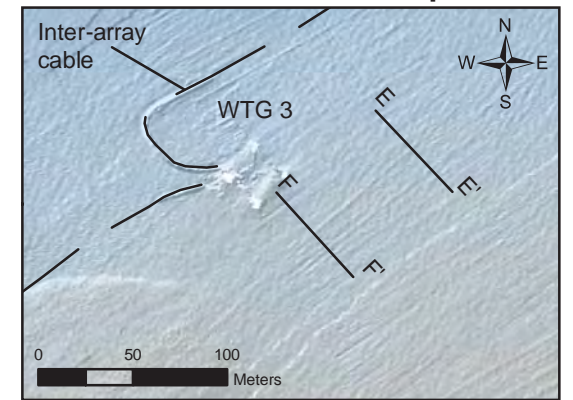

Notes:

The depressions shown in this figure were created by the L/B Brave Tern vessel while installing the wind turbine during Construction Season 2 that occurred in between Surveys 1 and 2. Bathymetry data shown in the plan views are from Survey 5.

**EXAMPLE OF SEAFLOOR RECOVERY
WIND TURBINE GENERATOR NO. 3**
Seafloor Monitoring Study
Block Island Wind Farm and Transmission Project
Offshore Rhode Island

N:\Projects\04_2015\04_8115_0001_BOEM_RODEO\BlockIsland_RI\Outputs\Post_Con_Survey_5\MXD\Fig-11_WTG3_Spud_Depression_Profiles.mxd, 1/11/2019, T.Weathers

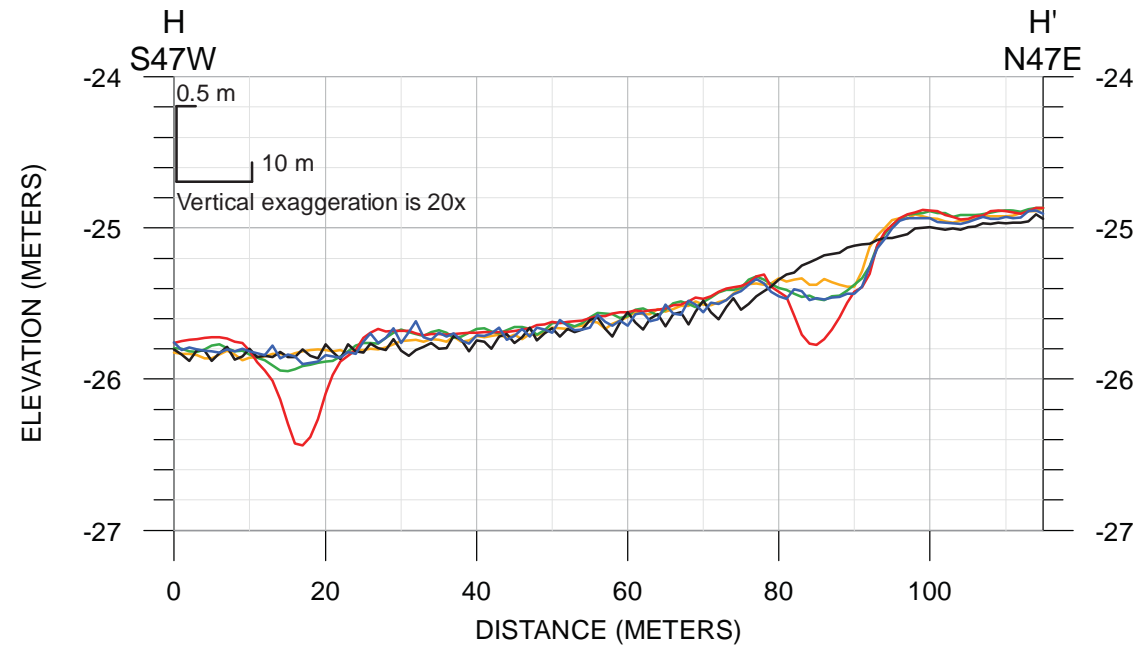
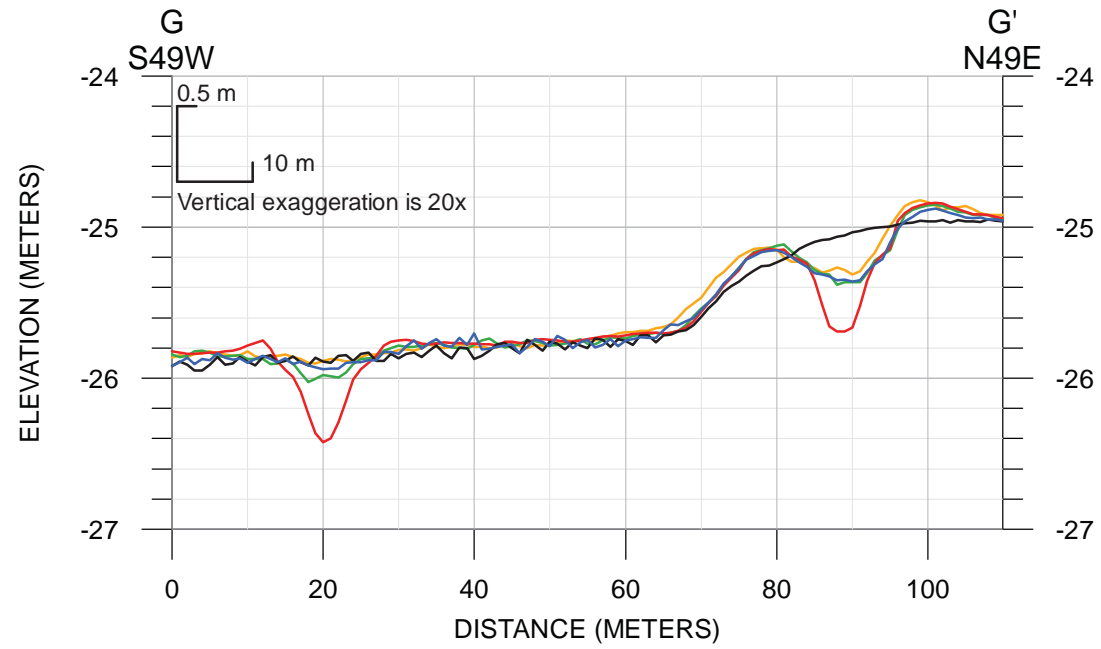

Legend

- Survey No. 1 (May 2016)
- Survey No. 2 (October 2016)
- Survey No. 3 (May 2017)
- Survey No. 4 (October 2017)
- Survey No. 5 (September 2018)

Profile Location Map

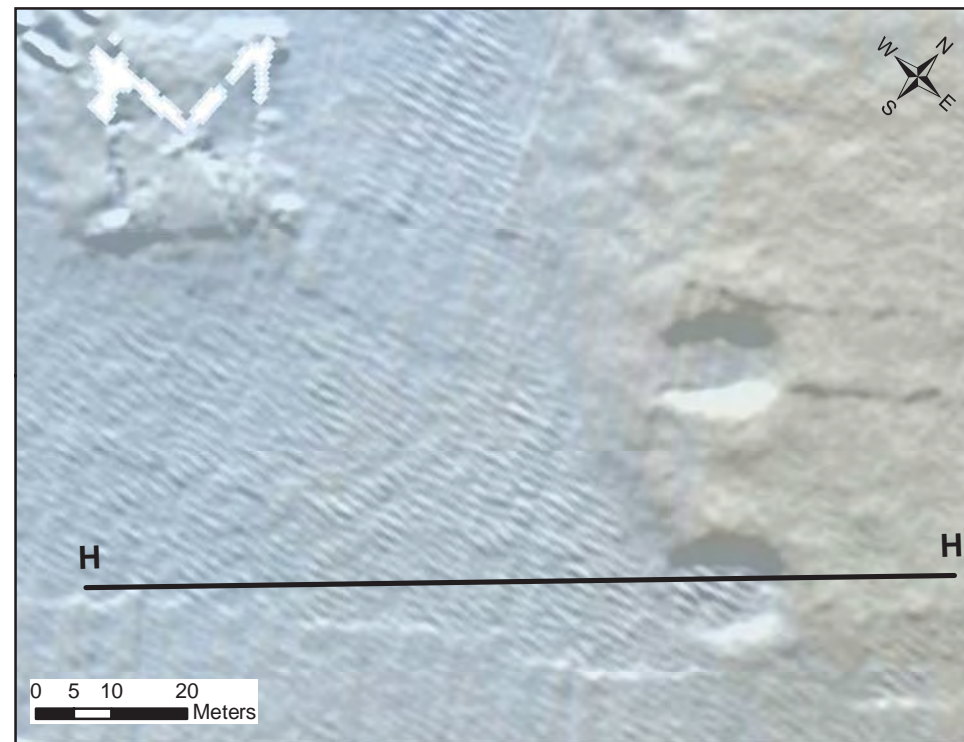
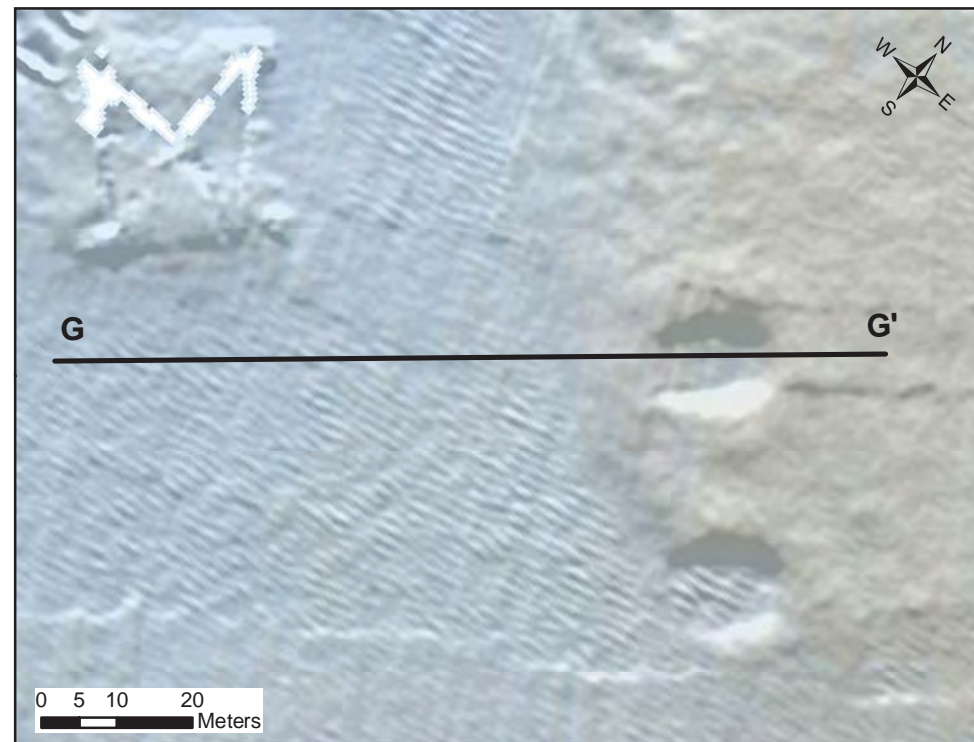
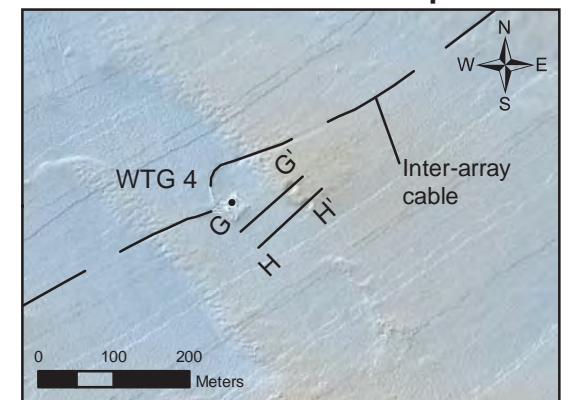

Notes:

The depressions shown in this figure were created by the L/B Brave Tern vessel while installing the wind turbine during Construction Season 2 that occurred in between Surveys 1 and 2. Bathymetry data shown in the plan views are from Survey 5.

**EXAMPLE OF SEAFLOOR RECOVERY
WIND TURBINE GENERATOR NO. 4**
Seafloor Monitoring Study
Block Island Wind Farm and Transmission Project
Offshore Rhode Island

N:\Projects\04_2015\04_8115_0001_BOEM_RODEO\BlockIsland_R1\Output\Post_Con_Survey_5\MXD\Fig-12_WTG4_Spud_Depression_Profiles.mxd, 1/11/2019, T. Weathers

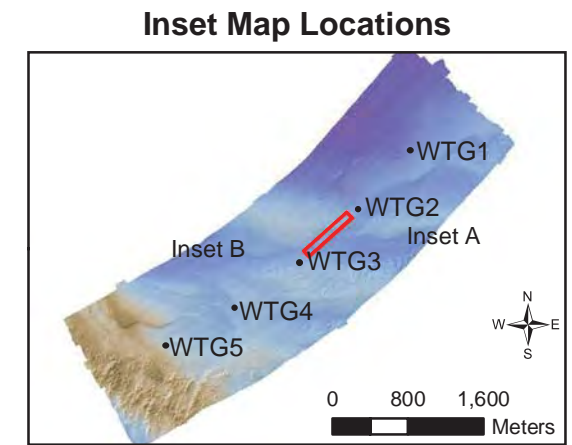
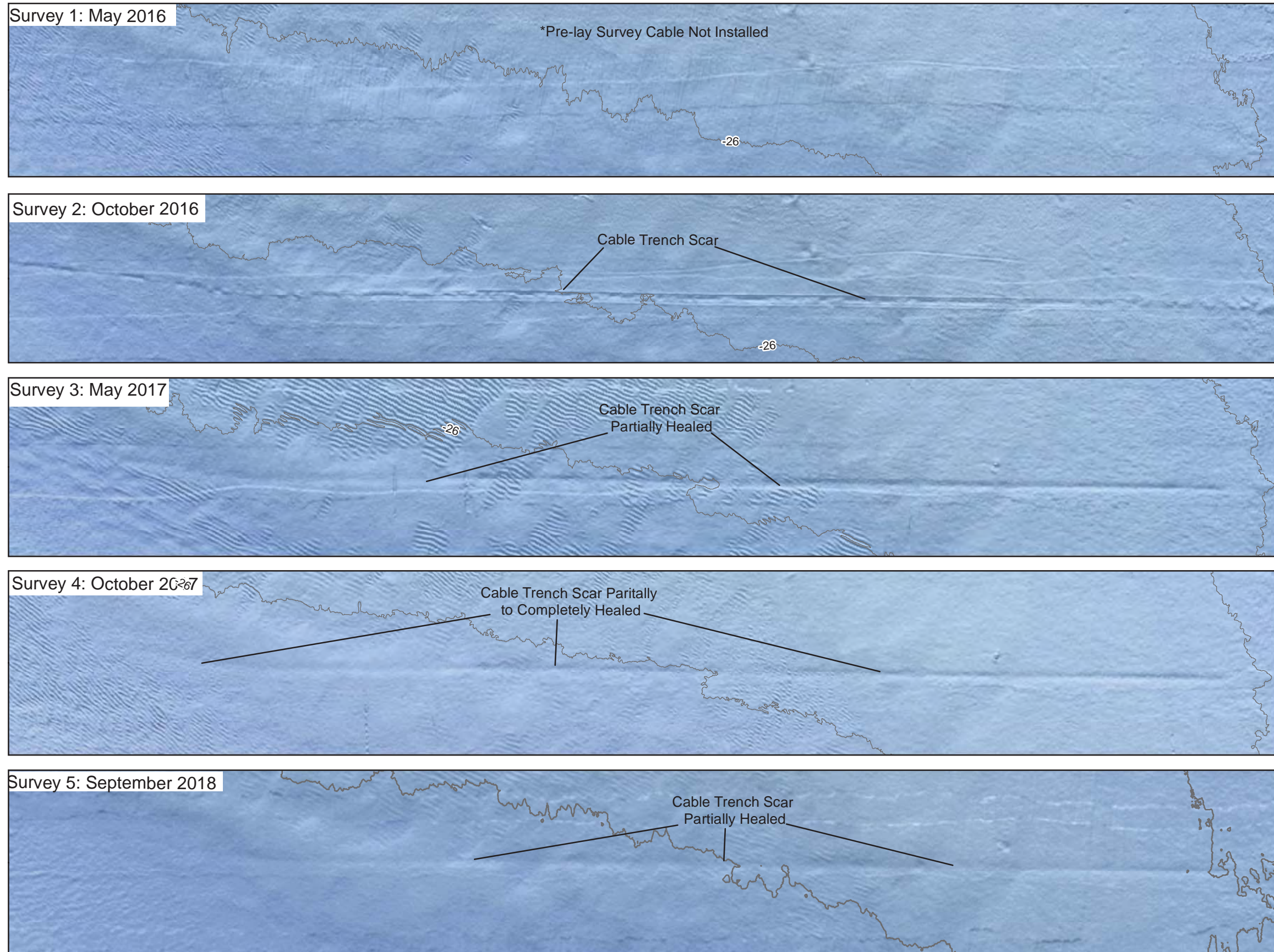

Notes:

The comparison of the inter-array cable from the four surveys (May 2016 through October 2017), indicate that cable trench scar has partially healed. The inter-array cable was installed between June and July 2016, and Survey 2 (Oct. 2016) showed that the trench scar was up to approximately 10 cm in depth in this area. Survey 3 (May 2017) showed in this same area that portions of the cable trench had completely healed while other areas were up to 7 cm deep. Survey 4 (Oct. 2017) showed that most of the cable trench in this extent had healed, with a few areas up to approximately 5 cm in depth.

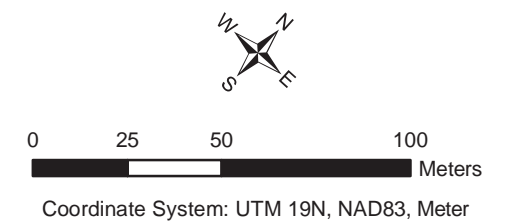

**INTER-ARRAY CABLE TRENCH
MAY 2016 THROUGH SEPTEMBER 2018 SURVEYS**
Seafloor Monitoring Study
Block Island Wind Farm and Transmission Project
Offshore Rhode Island

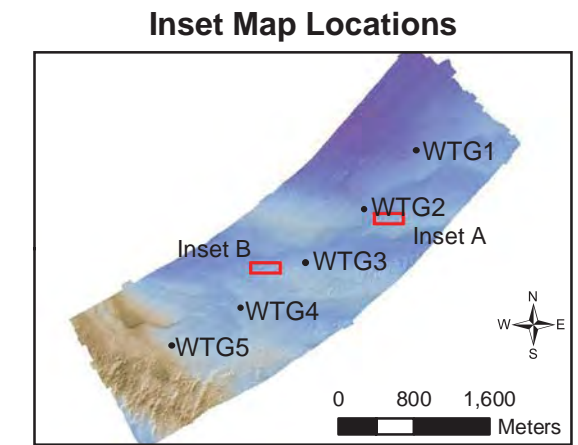
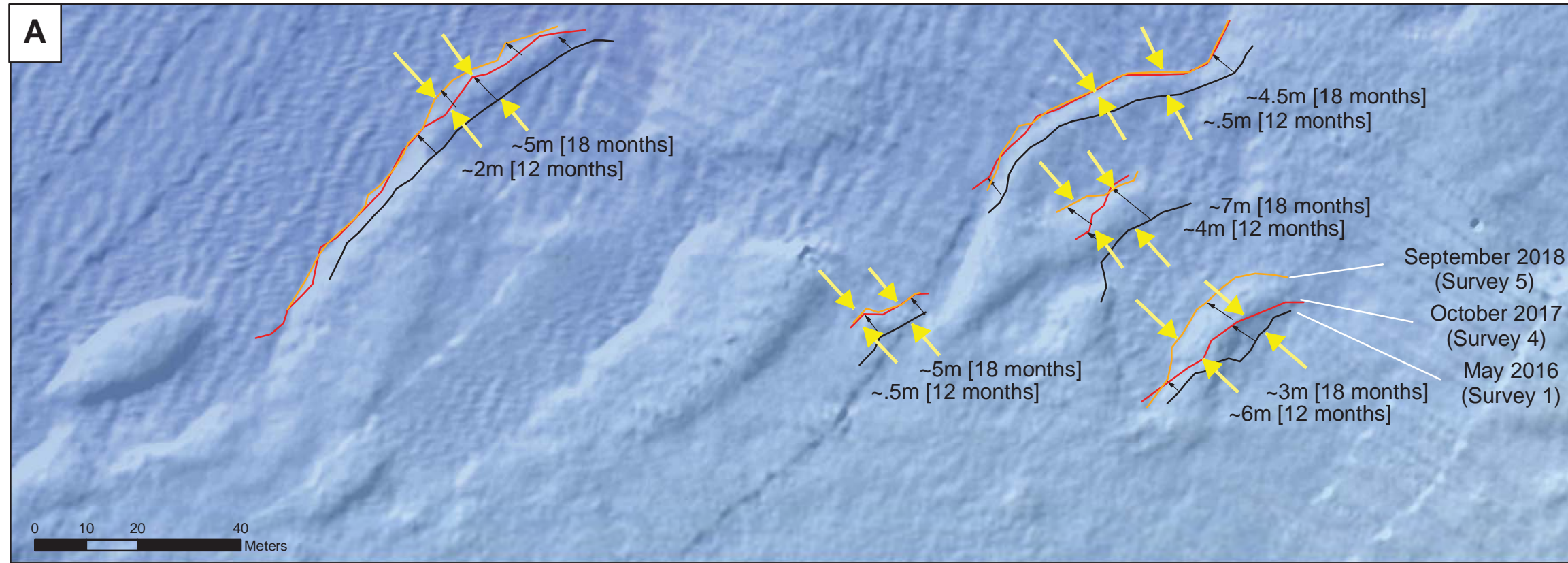

Notes:

The comparison of bedform features from the two surveys (October 2017 and September 2018) conducted over one year apart, indicate that the bedforms have shifted approximately 2 to 6 meters to the northwest compared to the previous comparison of 3 to 9 meters from May 2016 and October 2017. The orange, red, and black lines represent the interpreted features from the September 2018, October 2017, and May 2016 surveys, respectively.

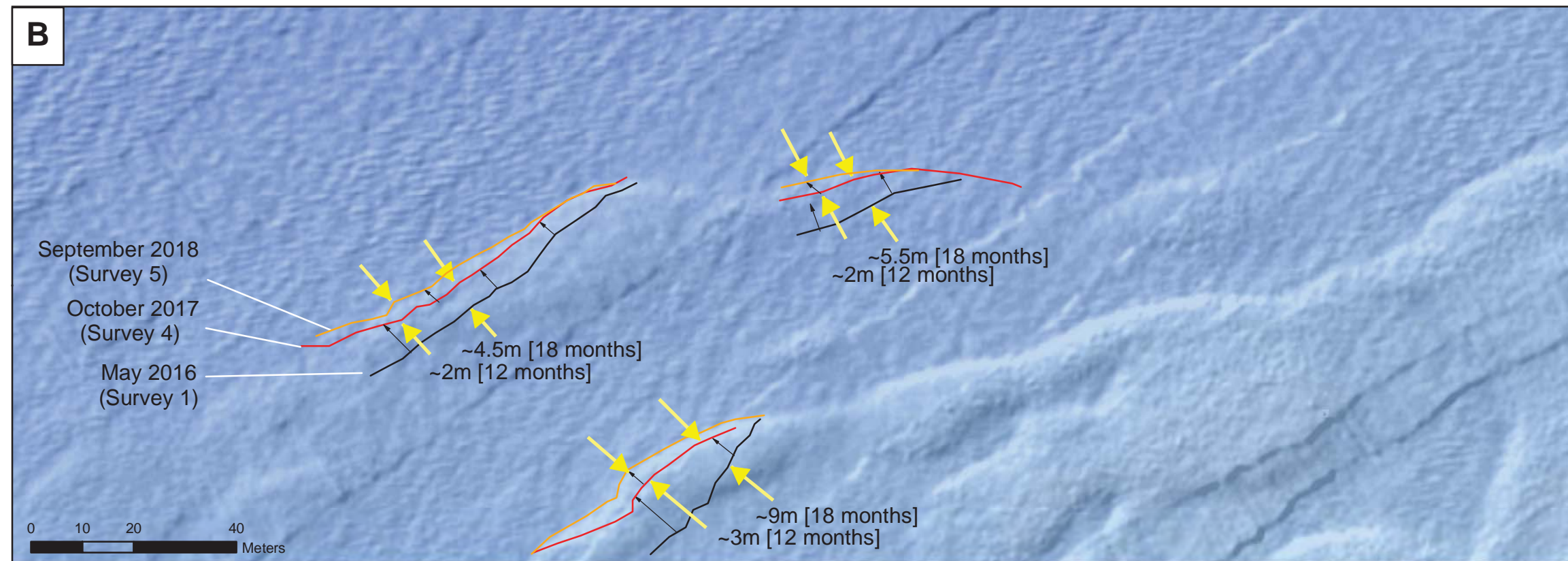

Coordinate System: UTM 19N, NAD83, Meter

**BEDFORM CHANGES REVEALED BY
OCTOBER 2017 AND SEPTEMBER 2018 SURVEYS**
Seafloor Monitoring Study
Block Island Wind Farm and Transmission Project
Offshore Rhode Island

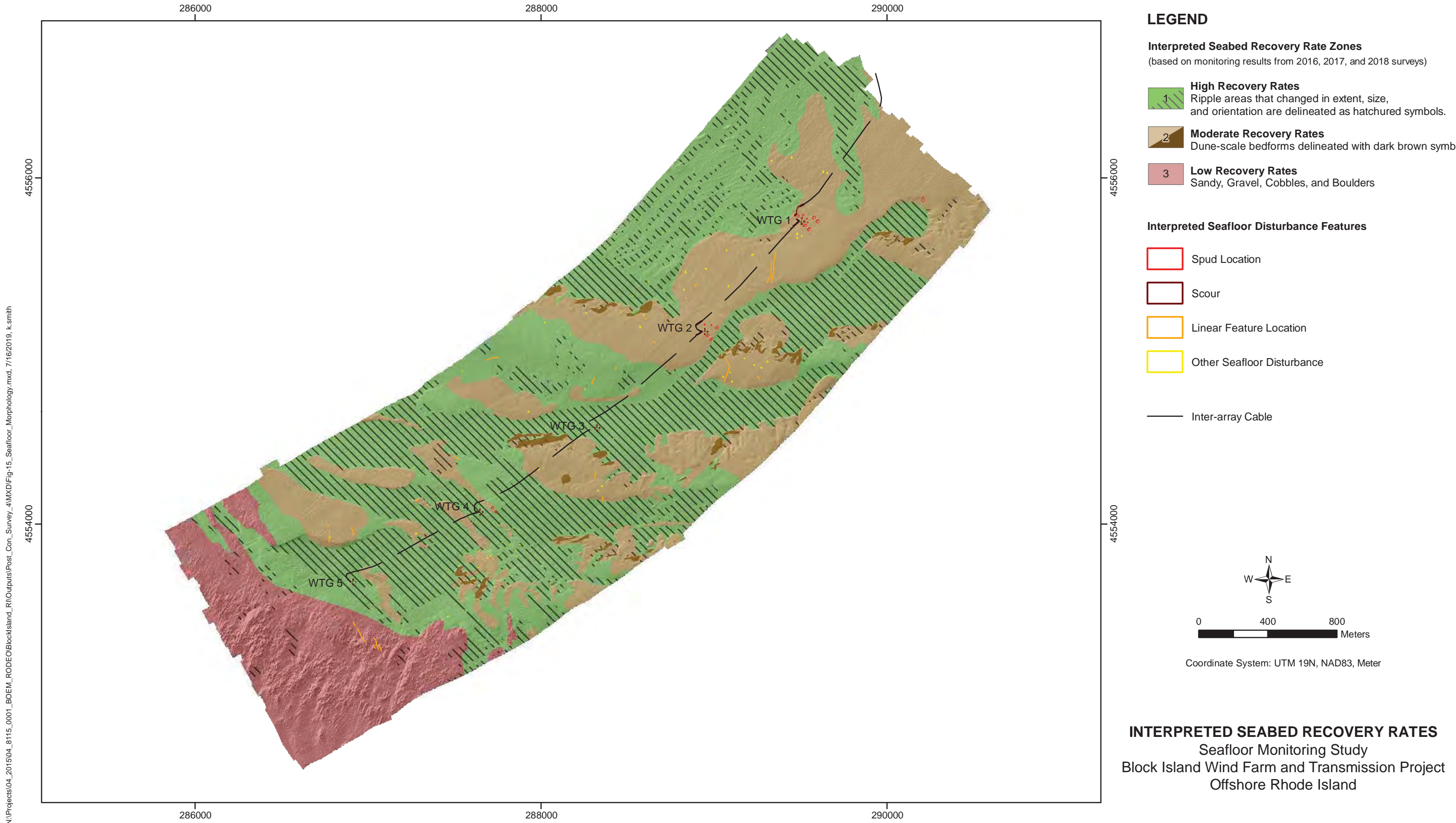

N:\Projects\04_2015\04_8115_0001_BOEM_RODEO\BlockIsland_R1\Output\Post_Con_Survey_4\AMXD\Fig-15_Seafloor_Morphology.mxd, 7/16/2019, k.smith

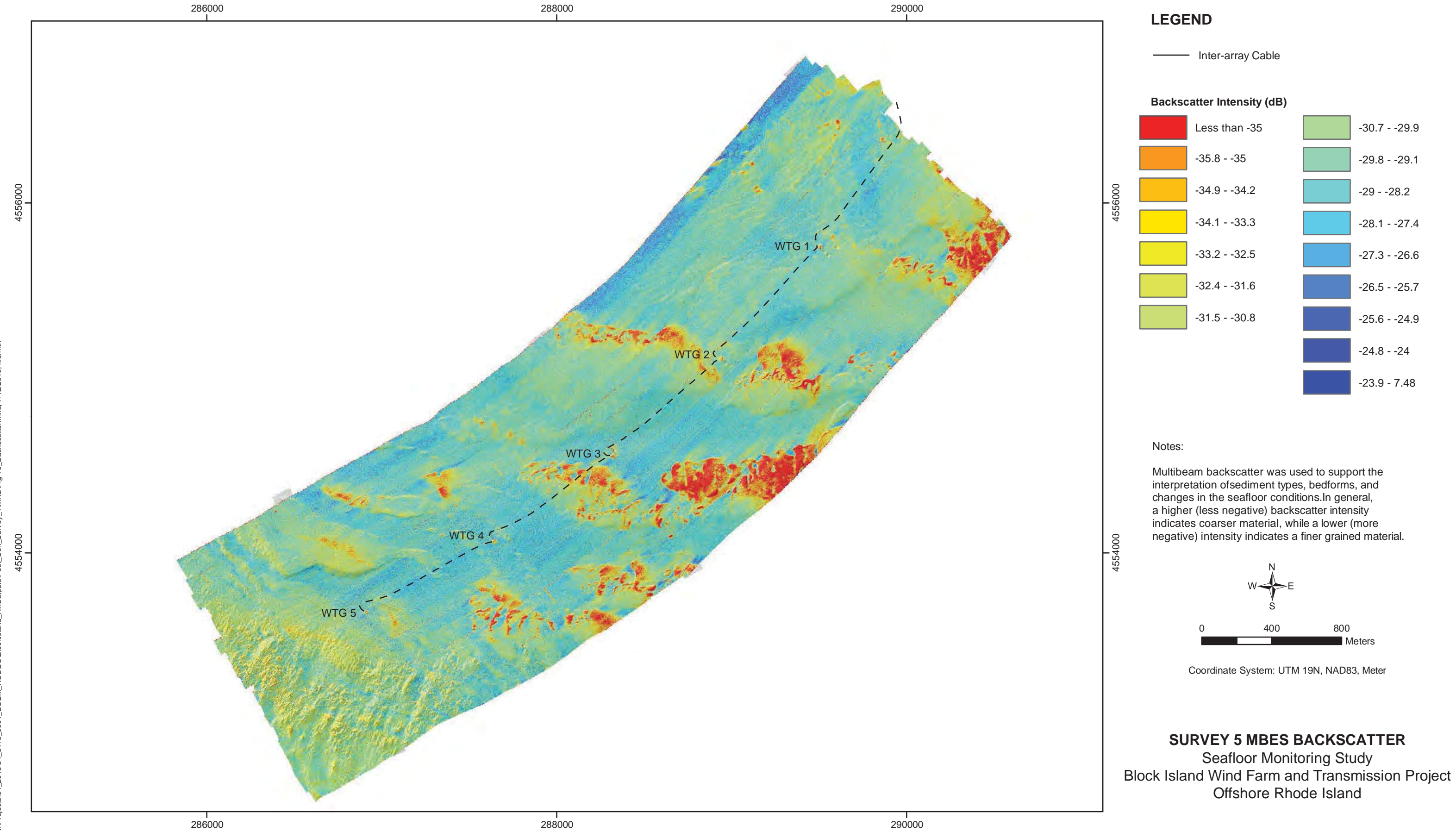

N:\Projects\04_2015\04_8115_0001_BOEM_BLOCKISLAND_R1\Output\Post_Con_Survey_4\MBES\Fig-16_Backscatter.mxd, 7/12/2019, k.smith

CHARTS

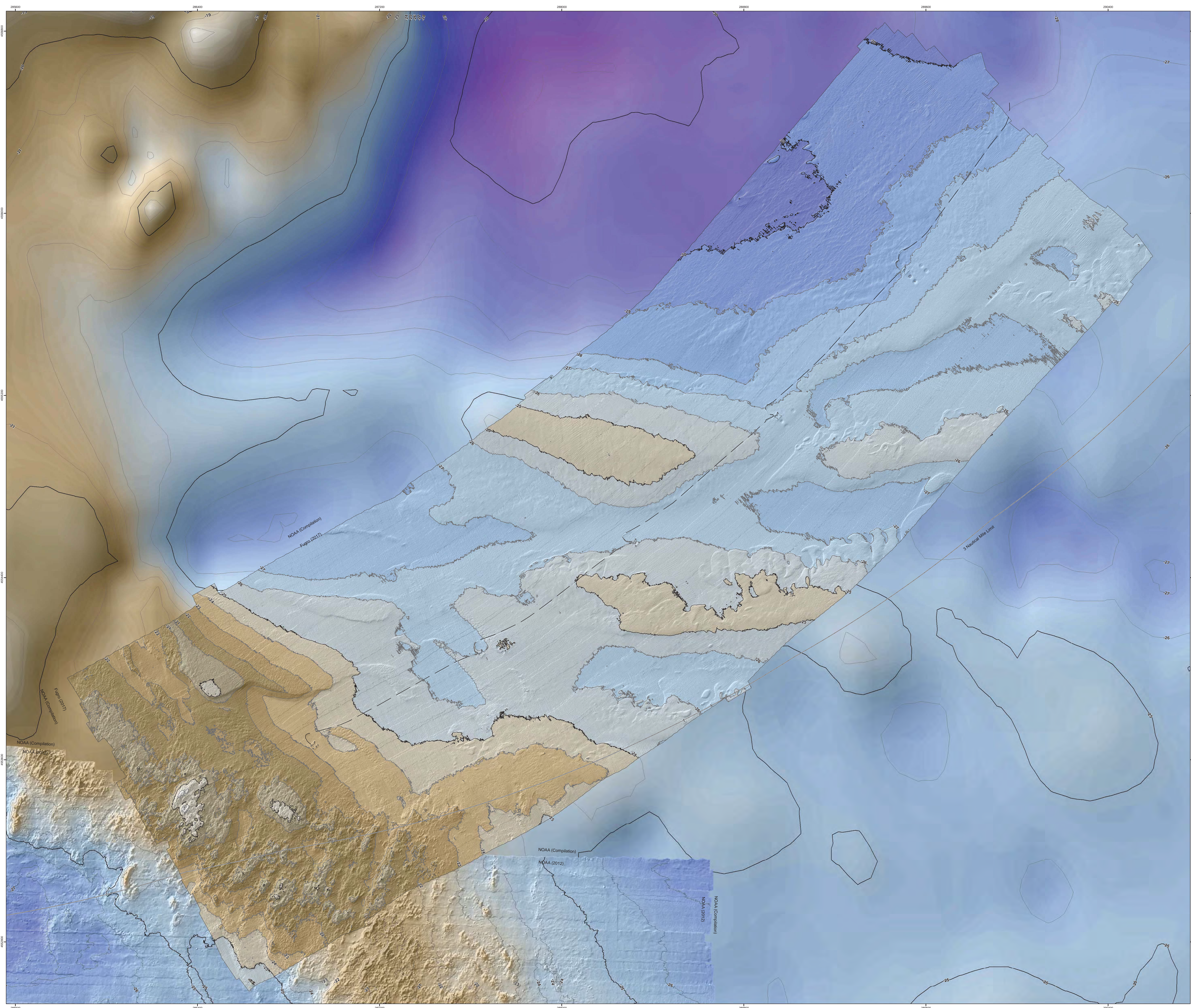

LEGEND

- - - Export Cable/Inner Array Cable
- 3 Nautical Mile Limit

Bathymetry (Meters, MLLW)

-18.9 - -18	-26.9 - -26
-19.9 - -19	-27.9 - -27
-20.9 - -20	-28.9 - -28
-21.9 - -21	-29.9 - -29
-22.9 - -22	-30.9 - -30
-23.9 - -23	-31.9 - -31
-24.9 - -24	-32.9 - -32
-25.9 - -25	-33.2 - -33

- Major Contour is 5 meters
- Minor Contour is 1 meter

- Notes:**
- Fugro marine survey data were collected on September 28 and 30, 2018 onboard the R/V Westley using a high-resolution integrated multibeam bathymetric survey system.
 - Differential Global Positioning System (DGPS) corrections were obtained from Fugro's ChirStar GNSS in real-time via a G2 subscription.
 - Survey equipment utilized for data collection included the following systems:
 - Hacon Seafloor 7120 S12 Multibeam Echo-sounder (MBES)
 - Applan POS MV 320 (4) Motion Reference Unit & Positioning System
 - Applied Microplane Limited (AML) SmartPhoto for Sound Velocity Profiles
 - PPS WinFog (3.10.43) navigation and data acquisition software
 - NOAA (2012) Multibeam bathymetric data is from the National Oceanic and Atmospheric Administration's (NOAA) hydrographic survey of Block Island Sound, New York. This survey was conducted August 25 through August 28, 2012.
 - NOAA Compiled Bathymetric data is a compilation of NOAA sounding files in the area that were collected between 1938 to 1979.

This document may only be used for the purposes for which it was commissioned and in accordance with the terms of engagement for that commission. Unauthorized use of this document in any form whatsoever is prohibited and is considered illegal.

GEODETTIC INFORMATION

SPHEROID:	GRS 1980
SEMI-MAJOR AXIS:	6,378,137.0000
SEMI-MINOR AXIS:	6,356,752.3141
FLATTENING:	298.257222101
ECCENTRICITY ² :	0.00680348
PROJECTION:	UNIVERSAL TRANSVERSE MERCATOR
ZONE:	ZONE 18 NORTH
LONGITUDE OF ORIGIN:	76.000
FALSE EASTING:	500,000
FALSE NORTHING:	0

+ Coordinate Grid is UTM Zone 18N
+ NAD 1983, Meters

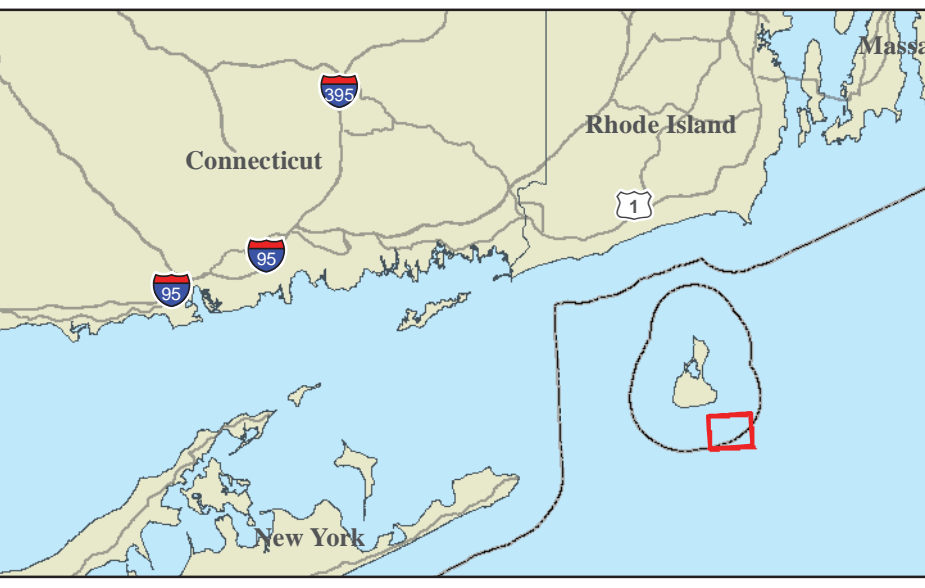

FUGRO FUGRO MARINE GEOSERVICES, INC.
 World Trade Center, Suite 350
 101 Water Main Street
 Norfolk, Virginia 23510
 Tel: (757) 625-3362
 Fax: (757) 625-3362
 www.fugro.com

SURVEY 5 (SEPTEMBER 2018) BATHYMETRY
Seafloor Monitoring Study
Block Island Wind Farm and Transmission Project
Offshore Rhode Island

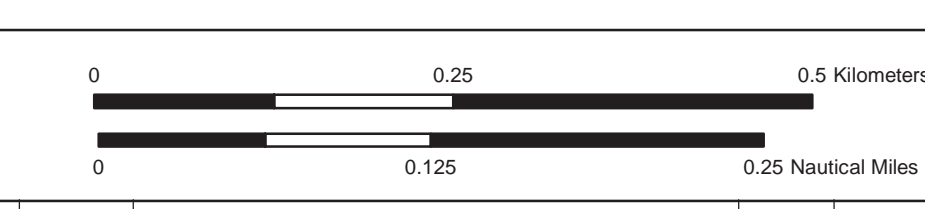

NO.	DATE	DESCRIPTION	DRAWN	CHKD	APPR.
1	Dec 2018	Survey 5 (Dec. 2018) Report	TAW	WBC	KRS
2					
3					

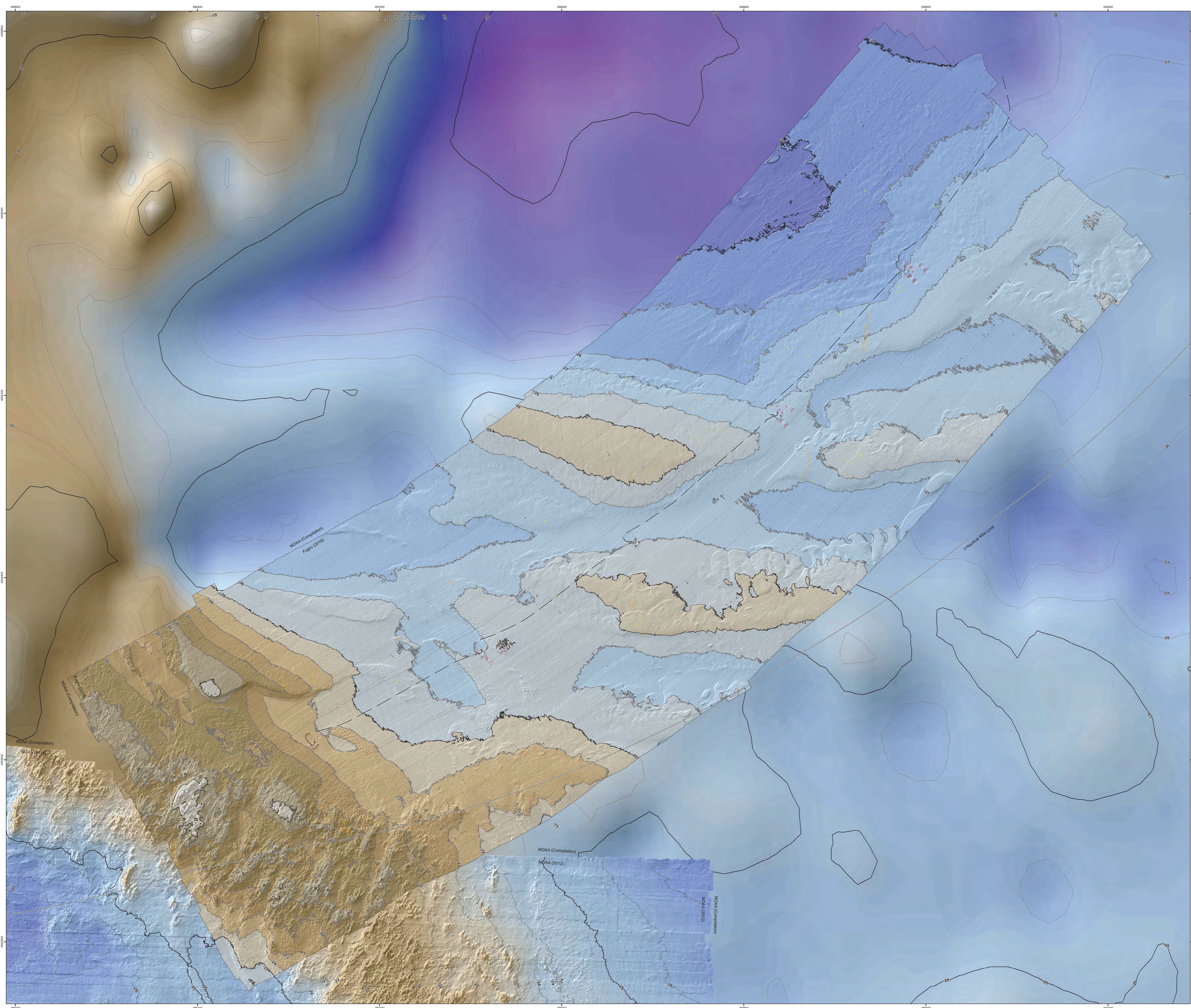

LEGEND

- Export Cable/Inner Array Cable
- 3 Nautical Mile Limit

Bathymetry (Meters, MLLW)

-18.0 - -18	-26.0 - -26
-19.0 - -19	-27.0 - -27
-20.0 - -20	-28.0 - -28
-21.0 - -21	-29.0 - -29
-22.0 - -22	-30.0 - -30
-23.0 - -23	-31.0 - -31
-24.0 - -24	-32.0 - -32
-25.0 - -25	-33.2 - -33

- Major Contour is 5 meters
- Minor Contour is 1 meter

Interpreted Seafloor Disturbance Features

- Spud Location
- Scour
- Linear Feature
- Other Seafloor Disturbance

- Notes:**
- Fugro marine survey data were collected on September 28 and 30, 2018 onboard the R/V Westerner using a high-resolution integrated multibeam bathymetric survey system.
 - Differential Global Positioning System (DGPS) corrections were obtained from Fugro's ChirixStar GNSS in real-time via a G2 subscription.
 - Survey equipment utilized for data collection included the following systems:
 - Hacon Seafloor 7120 S12 Multibeam Echo-sounder (MBES)
 - Applan POS MV 320 (4-B Motion Reference Unit & Positioning System)
 - Applied Microplane Limited (AML) SonarPro for Sound Velocity Profiles
 - PPS WinFrog (3.10.43) navigation and data acquisition software
 - NOAA (2012) Multibeam bathymetric data is from the National Oceanic and Atmospheric Administration's (NOAA) hydrographic survey of Block Island Sound, New York. This survey was conducted August 25 through August 28, 2012.
 - NOAA Compiled Bathymetric data is a compilation of NOAA sounding files in the area that were collected between 1938 to 1979.

This document may only be used for the purposes for which it was commissioned and in accordance with the terms of engagement for that commission. Unauthorized use of this document in any form whatsoever is prohibited and is considered illegal.

GEODETTIC INFORMATION

SPHEROID:	GRS 1980
SEMI-MAJOR AXIS:	6,378,137.0000
SEMI-MINOR AXIS:	6,356,752.3141
MEAN FLATTENING:	298.2572149
ECCENTRICITY ² :	0.0068034
PROJECTION:	UNIVERSAL TRANSVERSE MERCATOR
ZONE:	ZONE 18 NORTH
LONGITUDE OF ORIGIN:	70.000
FALSE EASTING:	50,000
FALSE NORTHING:	0

+ Coordinate Grid is UTM Zone 18N
+ NAD 1983, Meters

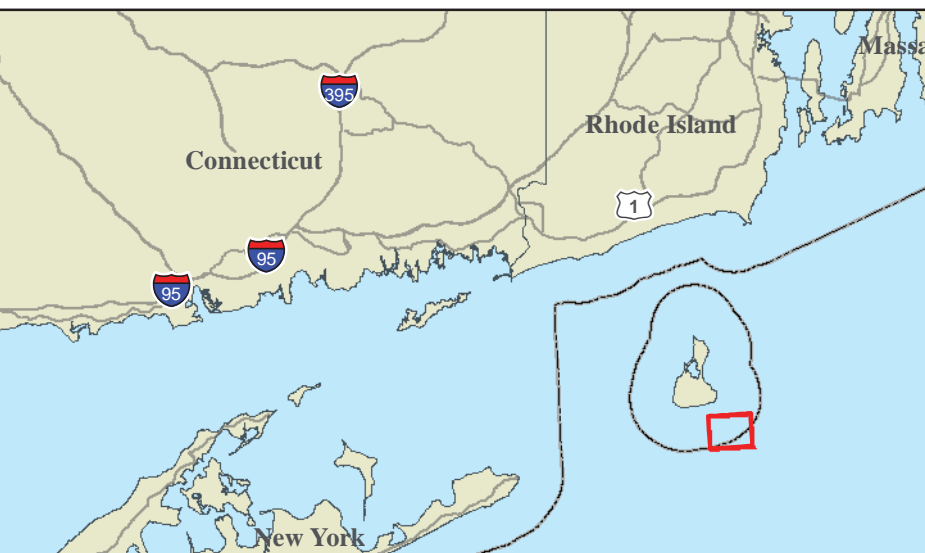

FUGRO FUGRO MARINE GEOSERVICES, INC.
 World Trade Center, Suite 350
 101 Water Main Street
 Norfolk, Virginia 23510
 Tel: (757) 625-3352
 Fax: (757) 625-3352
 www.fugro.com

INTERPRETED SEAFLOOR DISTURBANCE FEATURES FROM SURVEY 5 (SEP. 2018)
 Seafloor Monitoring Study
 Block Island Wind Farm and Transmission Project
 Offshore Rhode Island

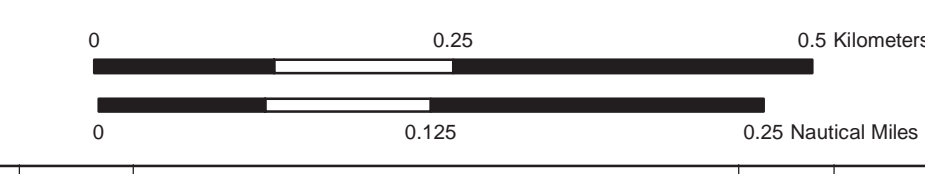

NO.	DATE	DESCRIPTION	DRAWN	CHKD	APPR
1	Dec. 2018	Survey 5 (Sep. 2018) Report	TAW	WBC	KRS
2					
3					

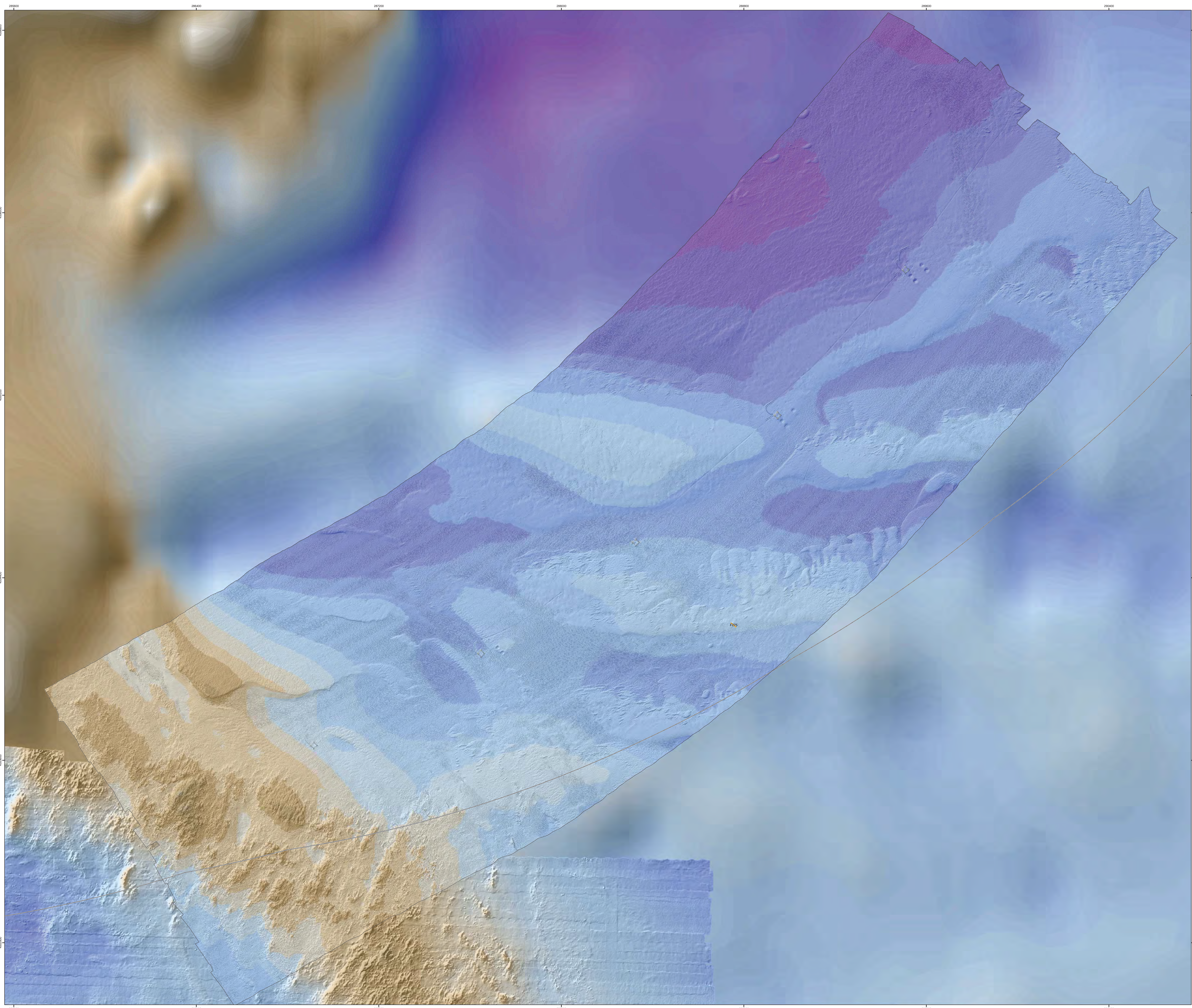

LEGEND

- - - Export Cable/Inter Array Cable
- 3 Nautical Mile Limit

Bathymetry (Meters, MLLW)

-16.9 to -16	-24.9 to -24
-17.9 to -17	-25.9 to -25
-18.9 to -18	-26.9 to -26
-19.9 to -19	-27.9 to -27
-20.9 to -20	-28.9 to -28
-21.9 to -21	-29.9 to -29
-22.9 to -22	-30.8 to -30
-23.9 to -23	

- Major Contour is 5 meters
- Minor Contour is 1 meter

Interpreted Seafloor Disturbance Features

- Linear Feature

- Notes:**
- Fugro marine survey data were collected on October 2 and 3, 2017 onboard the R/V Westerly using a high-resolution integrated multibeam bathymetric survey system.
 - Differential Global Positioning System (DGPS) corrections were obtained from Fugro's Omnistar GNSS in real-time via a G2 subscription.
 - Survey equipment utilized for data collection included the following systems:
 - Hacon Seabeck 7120 S12 Multibeam Echo-sounder (MBES);
 - Applan POS MV 320 (4-B Motion Reference Unit & Positioning System)
 - Applied Microplans Limited (AML) SmartPhoto for Sound Velocity Profiles
 - FPP's WinFrog (3.10.43) navigation and data acquisition software
 - NOAA (2012) Multibeam bathymetric data is from the National Oceanic and Atmospheric Administration's (NOAA) hydrographic survey of Block Island Sound, New York. This survey was conducted August 25 through August 28, 2012.
 - NOAA Complete Bathymetric data is a compilation of NOAA sounding files in the area that were collected between 1938 to 1979.

This document may only be used for the purposes for which it was commissioned and in accordance with the terms of engagement for that commission. Unauthorized use of this document in any form whatsoever is prohibited and is considered illegal.

GEODEIC INFORMATION

SPHEROID: GRS 1980
 SEMI-MJOR AXIS: 6,378,137.0000
 SEMI-MINOR AXIS: 6,356,752.3141
 MEAN FLATTENING: 298.2572141
 ECCENTRICITY²: 0.00672267
 PROJECTION: UNIVERSAL TRANSVERSE MERCATOR
 ZONE: 18N
 FALSE EASTING: 500,000
 FALSE NORTING: 0
 Coordinate GCS is UTM Zone 18N
 NAD 1983, Meters

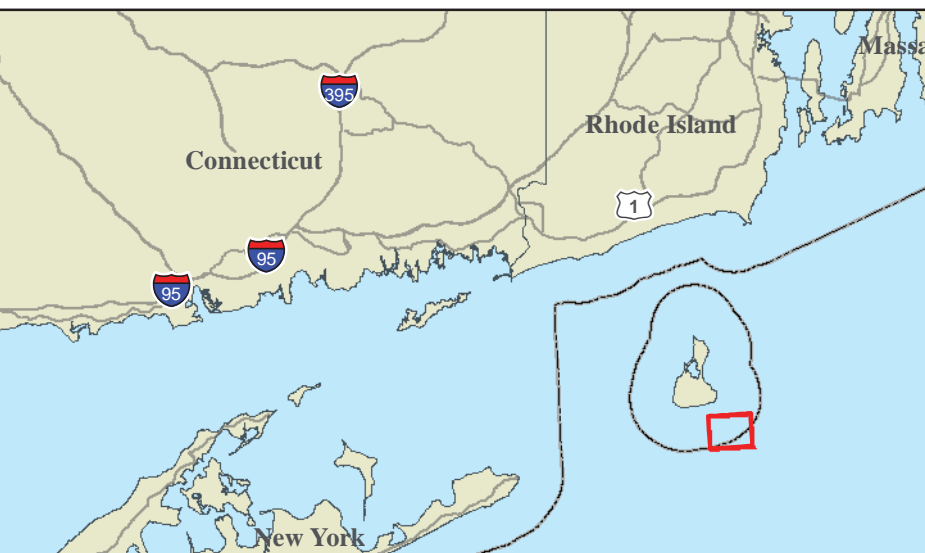

FUGRO FUGRO MARINE GEOSERVICES, INC.
 World Trade Center, Suite 350
 101 Water Main Street
 Norfolk, Virginia 23510
 Tel: (757) 625-3362
 Fax: (757) 625-3362
 www.fugro.com

INTERPRETED SEAFLOOR DISTURBANCE FEATURES FROM SURVEY 4 (OCT. 2017)
 Seafloor Monitoring Study
 Block Island Wind Farm and Transmission Project
 Offshore Rhode Island

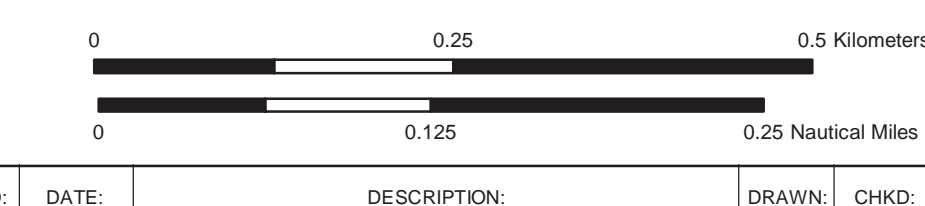

NO.	DATE	DESCRIPTION	DRAWN	CHKD	APPR.
1	Dec. 2016	Survey 5 (Dec. 2016) Report	TAW	WBC	KRS
2					
3					

JOB NUMBER: 02.81150001 CHART NO: 3

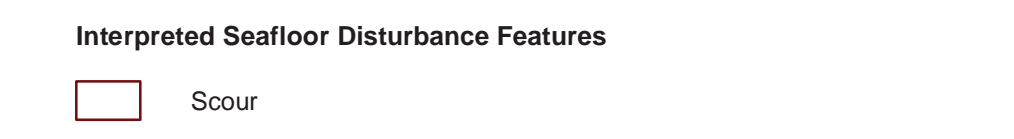
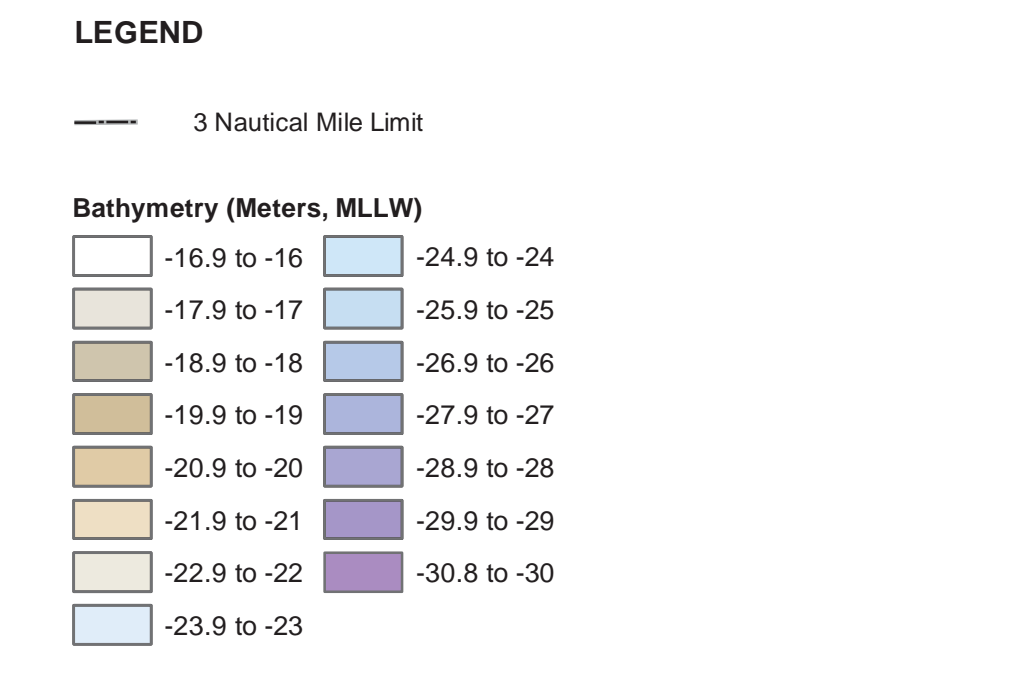
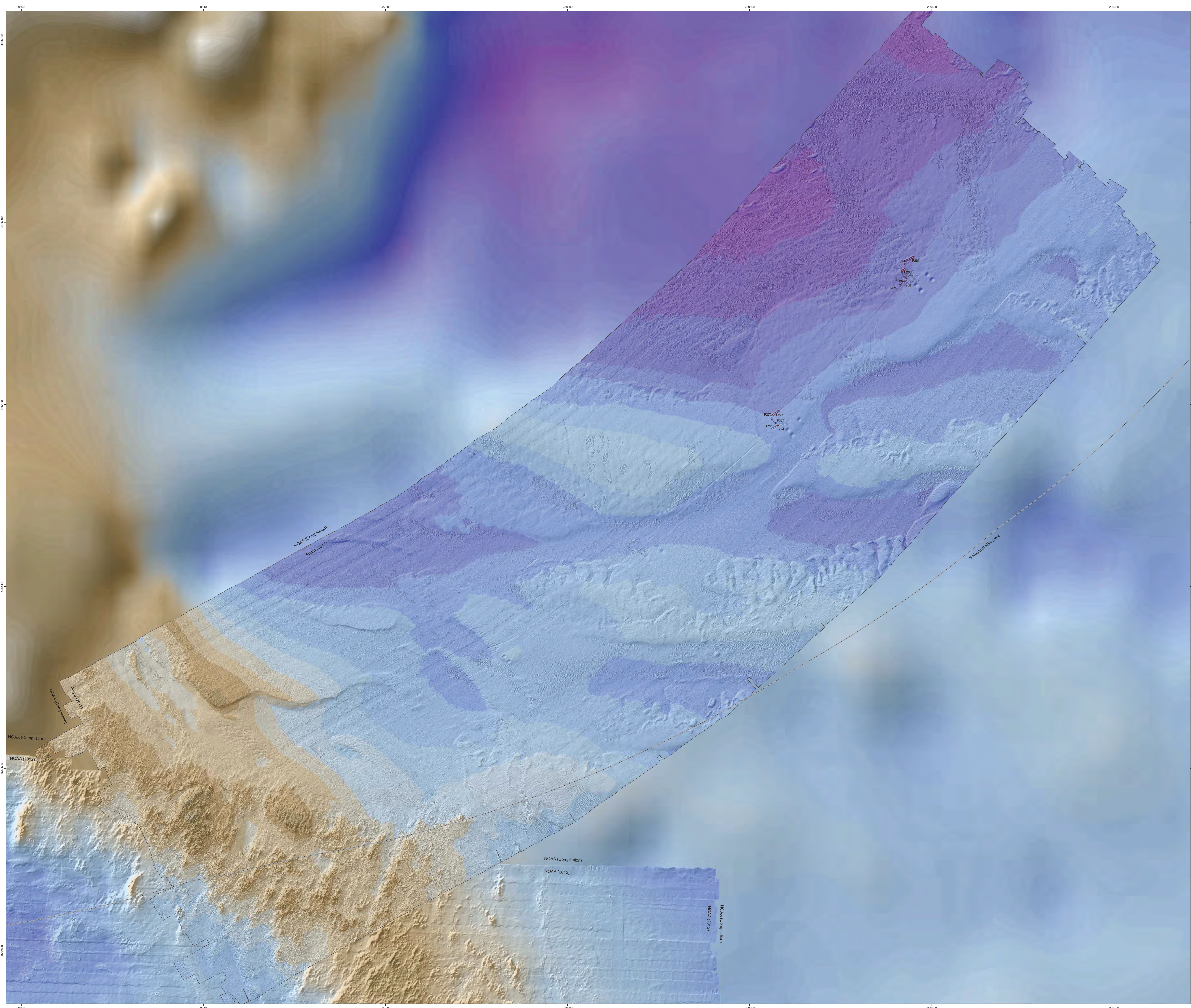

- Notes:**
- Fugro marine survey data were collected on May 18 and 19, 2017 onboard the R/V Waverly using a high-resolution integrated multibeam bathymetric survey system.
 - Differential Global Positioning System (DGPS) corrections were obtained from Fugro's Omnistar GNSS in real-time via a G2 subscription.
 - Survey equipment utilized for data collection included the following systems:
 - Hacon Seabat 7120 S12 Multibeam Echo-sounder (MBE);
 - Applan POS MV 320 (4) Motion Reference Unit & Positioning System;
 - Applied MicroSystems Limited (AML) SonarPro for Seabed Velocity Profiles;
 - FPP's WinFrog (3.10.43) navigation and data acquisition software.
 - NOAA (2012) Multibeam bathymetric data is from the National Oceanic and Atmospheric Administration's (NOAA) hydrographic survey of Block Island Sound, New York. This survey was conducted August 25 through August 28, 2012.
 - NOAA Compiled Bathymetric data is a compilation of NOAA sounding files in the area that were collected between 1938 to 1979.

This document may only be used for the purposes for which it was commissioned and in accordance with the terms of engagement for that commission. Unauthorized use of this document in any form whatsoever is prohibited. Not for navigational use.

GEODETTIC INFORMATION

SPHEROID:	GRS 1980
SEMI-MAJOR AXIS:	6,378,137.0000
SEMI-MINOR AXIS:	6,356,752.3141
MEAN FLATTENING:	298.257222101
ECCENTRICITY ² :	0.00672267
PROJECTION:	UNIVERSAL TRANSVERSE MERCATOR
ZONE:	ZONE 18 NORTH
FALSE EASTING:	500,000
FALSE NORTHING:	0

+ Coordinate Grid is UTM Zone 18N
NAO 18N, Meters

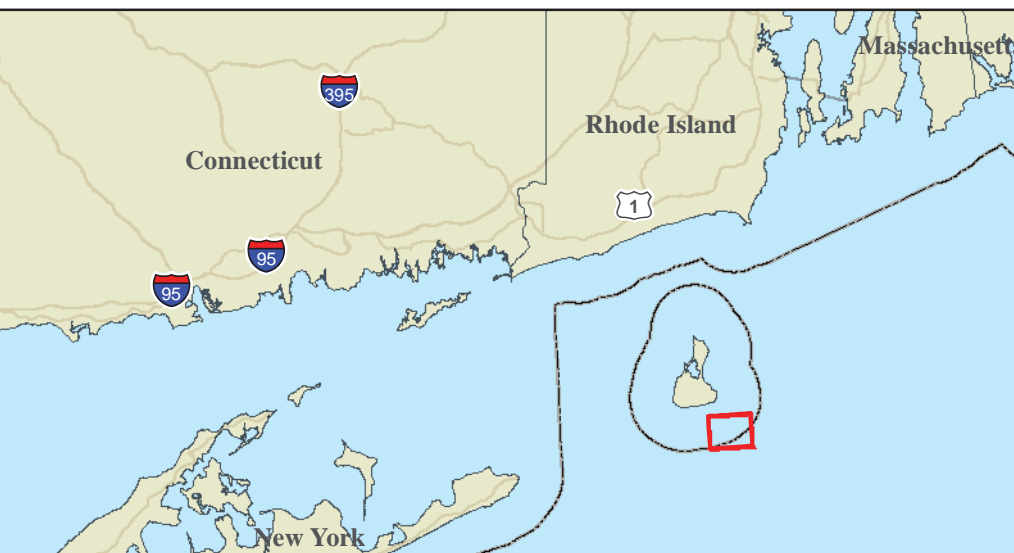

FUGRO FUGRO MARINE GEOSERVICES, INC.
 World Trade Center, Suite 350
 101 Water Main Street
 Norfolk, Virginia 23510
 Tel: (757) 625-3362
 Fax: (757) 625-3362
 www.fugro.com

SEAFLOOR DISTURBANCE FEATURE CATALOGUE FROM SURVEY 3 (MAY 2017)
 Seafloor Monitoring Study
 Block Island Wind Farm and Transmission Project
 Offshore Rhode Island

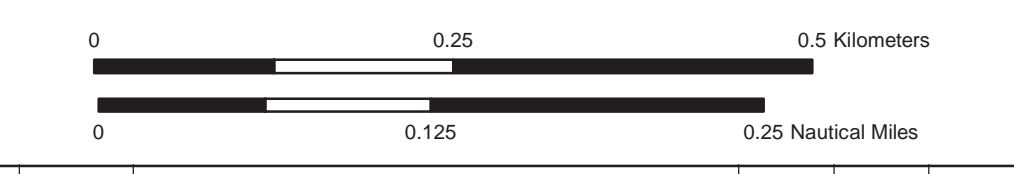

NO.	DATE	DESCRIPTION	DRAWN	CHKD	APPR
1	Dec. 2016	Survey 3 (Dec. 2016) Report	TAW	WBC	KRS
2					
3					

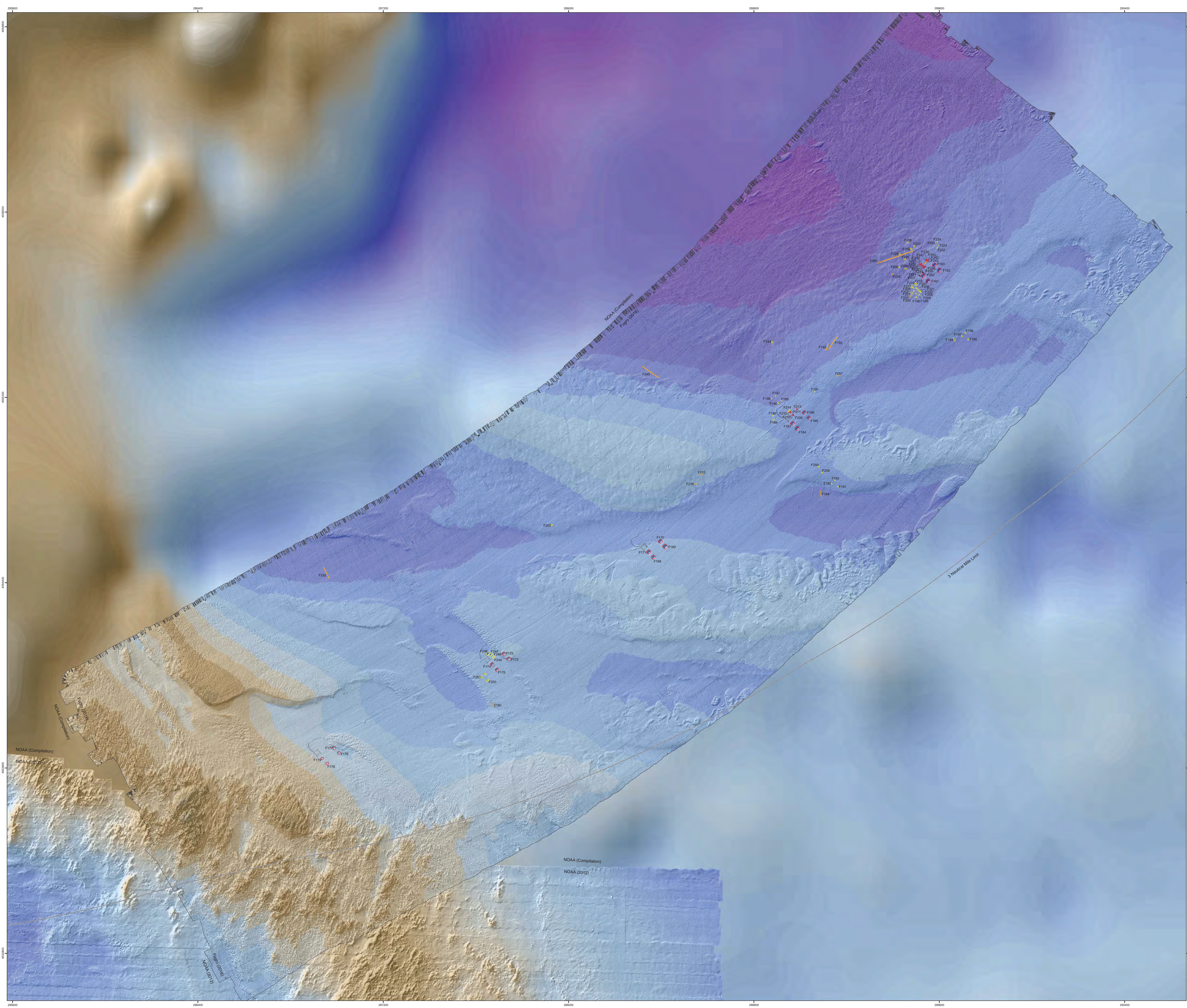

LEGEND

— 3 Nautical Mile Limit

Bathymetry (Meters, MLLW)

-16.9 to -16	-24.9 to -24
-17.9 to -17	-25.9 to -25
-18.9 to -18	-26.9 to -26
-19.9 to -19	-27.9 to -27
-20.9 to -20	-28.9 to -28
-21.9 to -21	-29.9 to -29
-22.9 to -22	-30.8 to -30
-23.9 to -23	

Interpreted Seafloor Disturbance Features

- Spud Location
- Scour
- Linear Feature
- Other Seafloor Disturbance

- Notes:**
- Fugro marine survey data were collected from October 02 through October 05, 2016 onboard the R/V Westley using a high-resolution integrated multibeam bathymetric survey system.
 - Differential Global Positioning System (DGPS) corrections were obtained from Fugro's OnStar GNSS in real-time via a G2 subscription.
 - Survey equipment utilized for data collection included the following systems:
 - Shoens Seabed 7120 S12 Multibeam Echo-sounder (MBE)
 - Applan POS MV 320 (4) Motion Reference Unit & Positioning System
 - Applied Microplane Limited (AML) SmartPhoto for Seabed Velocity Profiles
 - IPP's WinFrog (3.10.43) navigation and data acquisition software
 - NOAA (2012) Multibeam bathymetric data is from the National Oceanic and Atmospheric Administration's (NOAA) hydrographic survey of Block Island Sound, New York. This survey was conducted August 25 through August 28, 2012.
 - NOAA Compiled Bathymetric data is a compilation of NOAA sounding files in the area that were collected between 1938 to 1979.

This document may only be used for the purpose for which it was commissioned and in accordance with the terms of agreement for the commission. Unauthorized use of this document in any form whatsoever is prohibited. Not for navigational use.

GEODETTIC INFORMATION

SPHEROID:	GRS 1987
SEMI MAJOR AXIS:	6 378 137.000
SEMI MINOR AXIS:	6 378 111.404
INVERSE FLATTENING:	298.257222101
ECCENTRICITY:	0.0067226675
PROJECTION:	UNIVERSAL TRANSVERSE MERCATOR
ZONE:	18N
COORDINATE OF ORIGIN:	0
FALSE EASTING:	500 000
FALSE NORTHING:	0

↑ Coordinate Grid is UTM Zone 18N
↑ 1:63,000



FUGRO FUGRO MARINE GEOSERVICES, INC.

World Trade Center, Suite 350
100 West Main Street
Newport, Rhode Island 02840
Tel: (781) 425-3300
Fax: (781) 425-3302
www.fugro.com

SEAFLOOR DISTURBANCE FEATURE CATALOGUE FROM SURVEY 2 (OCT. 2016)
Seafloor Monitoring Study
Block Island Wind Farm and Transmission Project
Offshore Rhode Island

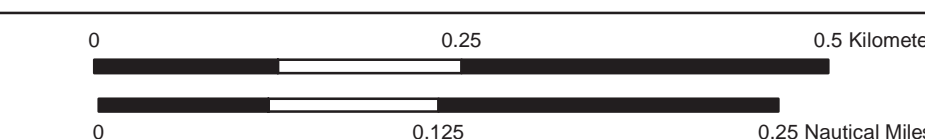

NO.	DATE	DESCRIPTION	DRAWN	CHKD	APPR
1	Dec. 2016	Survey 2 (Dec. 2016) Report	TAW	WBC	KRS
2					
3					

JOB NUMBER: 02.81150001 CHART NO.: 5

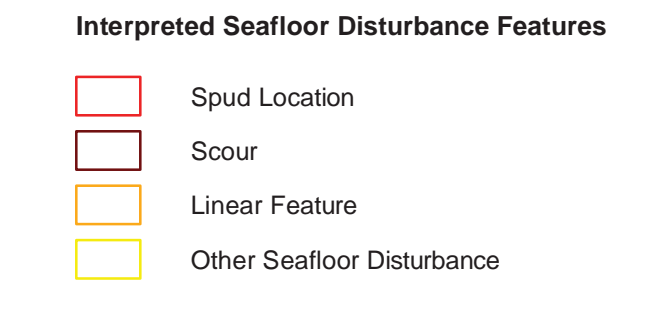
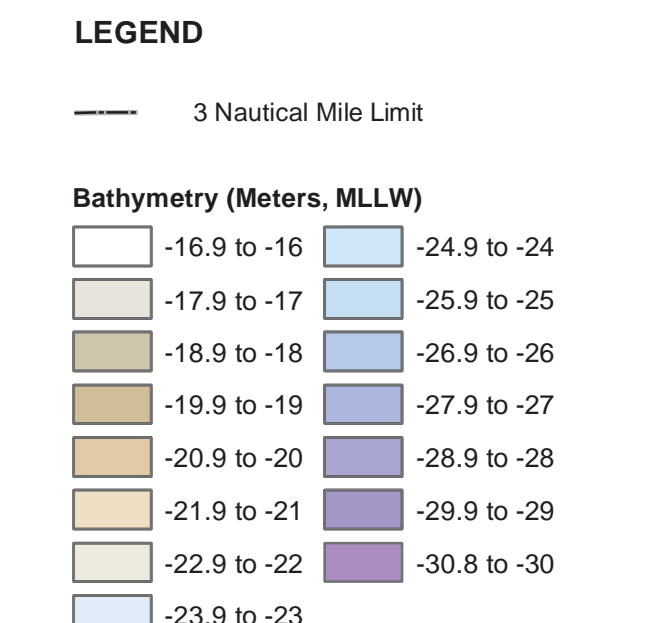
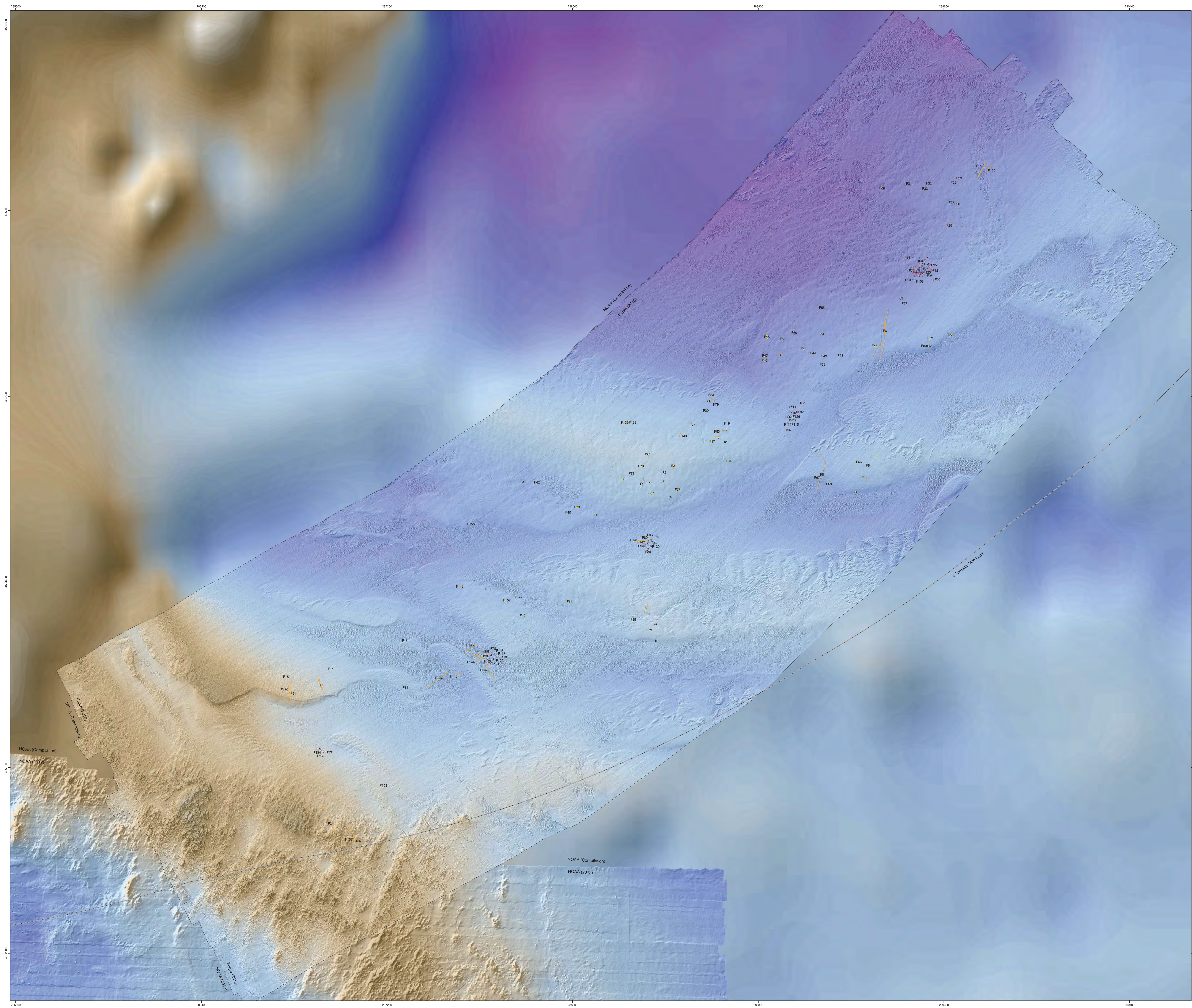

- Notes:**
- Fugro marine survey data were collected from May 11 through May 13, 2016 onboard the R/V James Herra using a high-resolution integrated multibeam bathymetric survey system.
 - Differential Global Positioning System (DGPS) corrections were obtained from Fugro's Omnistar GNSS in real-time via a G2 subscription.
 - Survey equipment utilized for data collection included the following systems:
 - Shimadzu 7125 S12 Multibeam Echo-sounder (MBE);
 - Applan POS MV 320 (4-in Motion Reference Unit & Positioning System);
 - Applied MicroSystems Limited (AML) SmartPhoto for Sound Velocity Profiles;
 - FPP's WinFrog (3.10.43) navigation and data acquisition software.
 - NOAA (2012) Multibeam bathymetric data is from the National Oceanic and Atmospheric Administration's (NOAA) hydrographic survey of Block Island Sound, New York. This survey was conducted August 25 through August 28, 2012.
 - NOAA Complete Bathymetric data is a compilation of NOAA sounding files in the area that were collected between 1938 to 1979.

This document may only be used for the purposes for which it was commissioned and in accordance with the terms of engagement for that commission. Unauthorized use of this document in any form whatsoever is prohibited and is considered illegal.

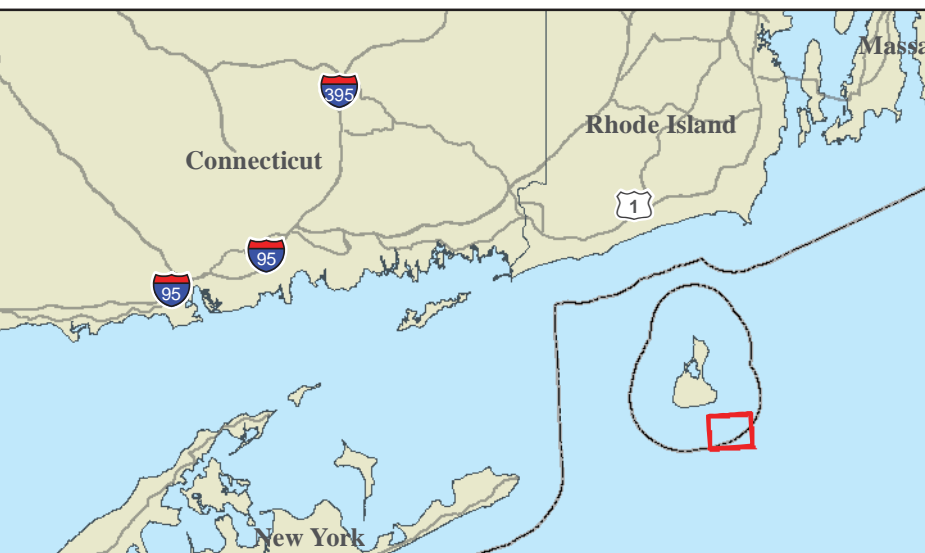

FUGRO FUGRO MARINE GEOSERVICES, INC.
 World Trade Center, Suite 350
 101 Water Main Street
 Norfolk, Virginia 23510
 Tel: (757) 625-3362
 Fax: (757) 625-3362
 www.fugro.com/marine

SEAFLOOR DISTURBANCE FEATURE CATALOGUE FROM SURVEY 1 (MAY 2016)
 Seafloor Monitoring Study
 Block Island Wind Farm and Transmission Project
 Offshore Rhode Island

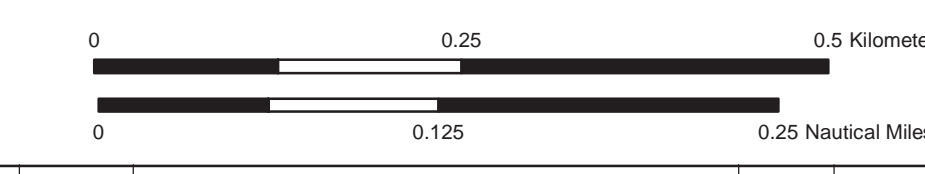

NO.	DATE	DESCRIPTION	DRAWN	CHKD	APPR
1	Dec. 2016	Survey 1 (Dec. 2016) Report	MKG	WBC	KRS
2					
3					

A: July 2016 Survey

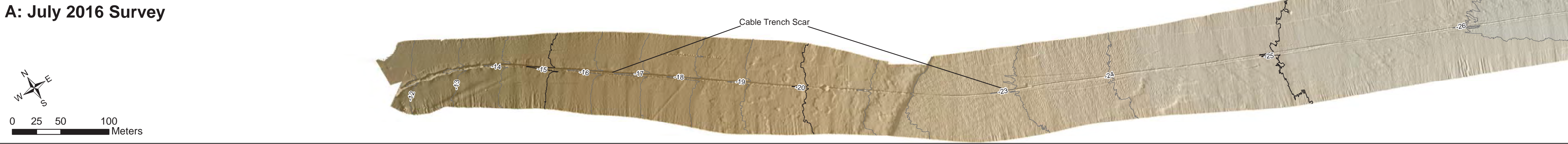

A: October 2016 Survey

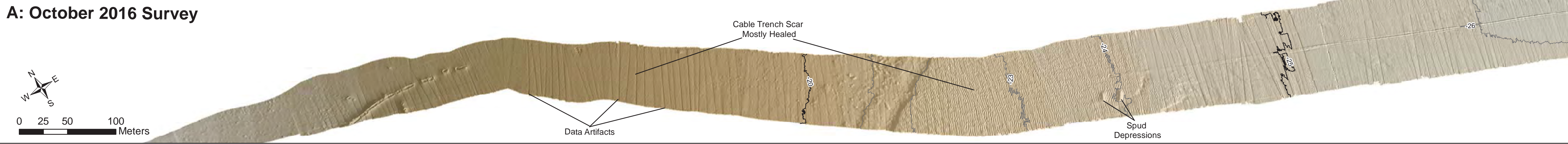

B: July 2016 Survey

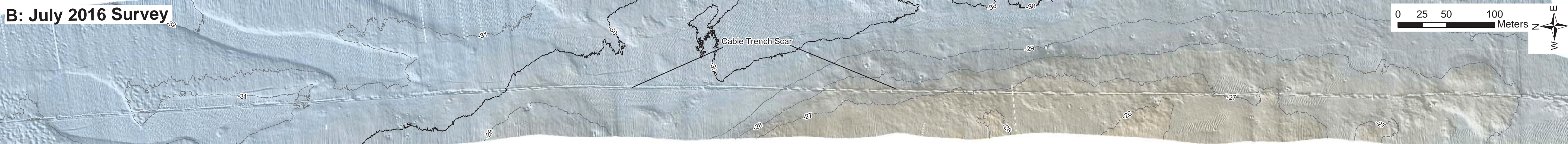

B: October 2016 Survey

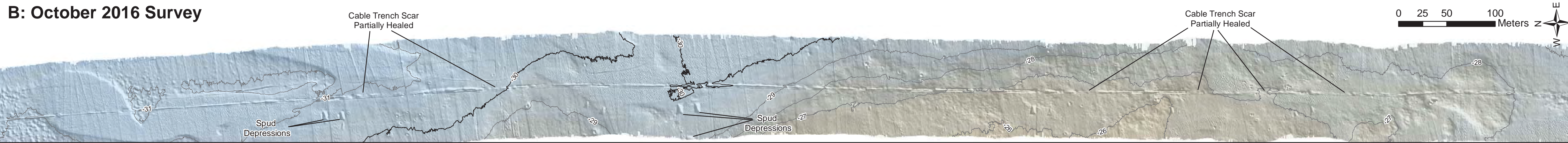

C: July 2016 Survey

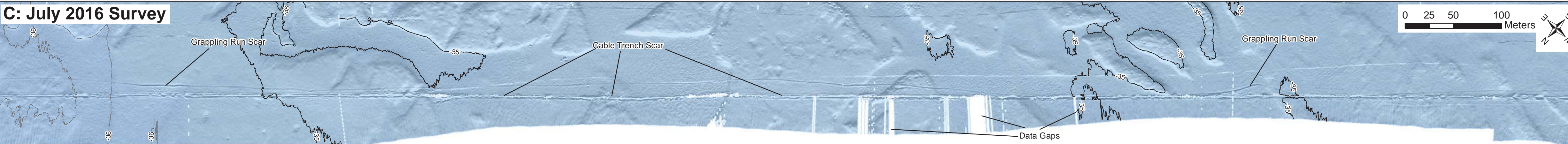

C: October 2016 Survey

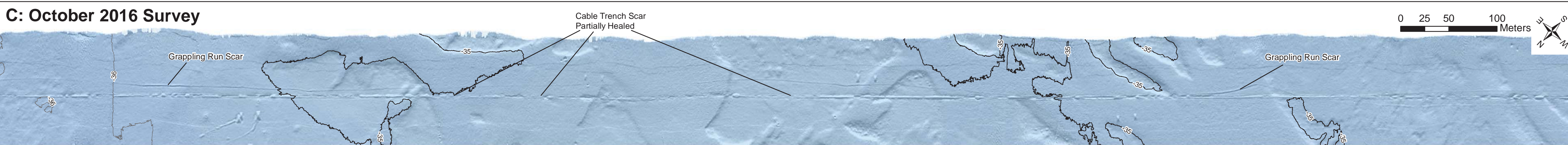

D: May 2016 Survey

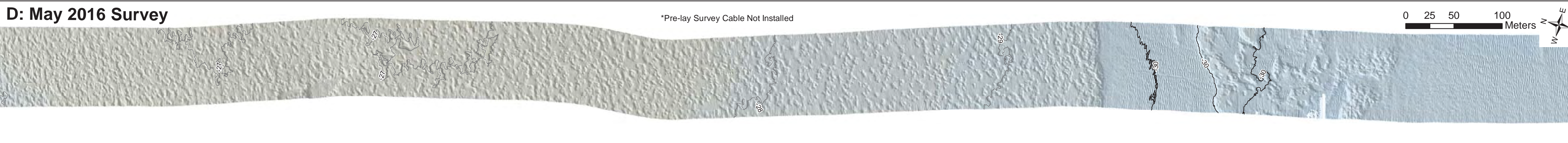

D: October 2016 Survey

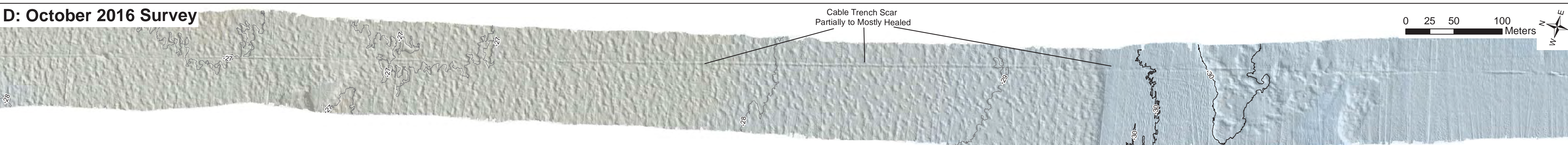

LEGEND

Bathymetry (Meters, MLLW)

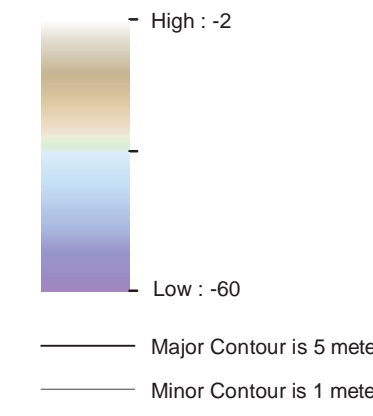

Notes:

- Fugro marine survey data were collected using a high-resolution integrated multibeam bathymetric survey system.
- Differential Global Positioning System (DGPS) corrections were obtained from Fugro's OmniStar GNSS in real-time via a G2 subscription.
- Survey equipment utilized for data collection included the following systems:
 -Reson SeaBat 7125 SV2 Multibeam Echosounder (MBES)
 -Applanix POS MV 320 (v4) Motion Reference Unit & Positioning System
 -Applied Microsystems Limited (AML) SmartProbe for Sound Velocity Profiles
 -FPI's WinFrog (v3.10.49) navigation and data acquisition software

This document may only be used for the purpose for which it was commissioned and in accordance with the terms of engagement for that commission. Unauthorized use of this document in any form whatsoever is prohibited. Not for navigational use.

GEODETTIC INFORMATION

SPHEROID: GRS 1982
 SEMI-MAJOR AXIS: 6,378,137.0000
 SEMI-MINOR AXIS: 6,356,752.3141
 INVERSE FLATTENING: 298.257222101
 ECCENTRICITY²: 0.006694380
 PROJECTION: UNIVERSAL TRANSVERSE MERCATOR
 ZONE: 19 NORTH
 LONGITUDE OF ORIGIN: 0
 FALSE EASTING: 500,000
 FALSE NORTHING: 0
 Coordinate Grid is UTM Zone 19N, NAD 1983, Meters

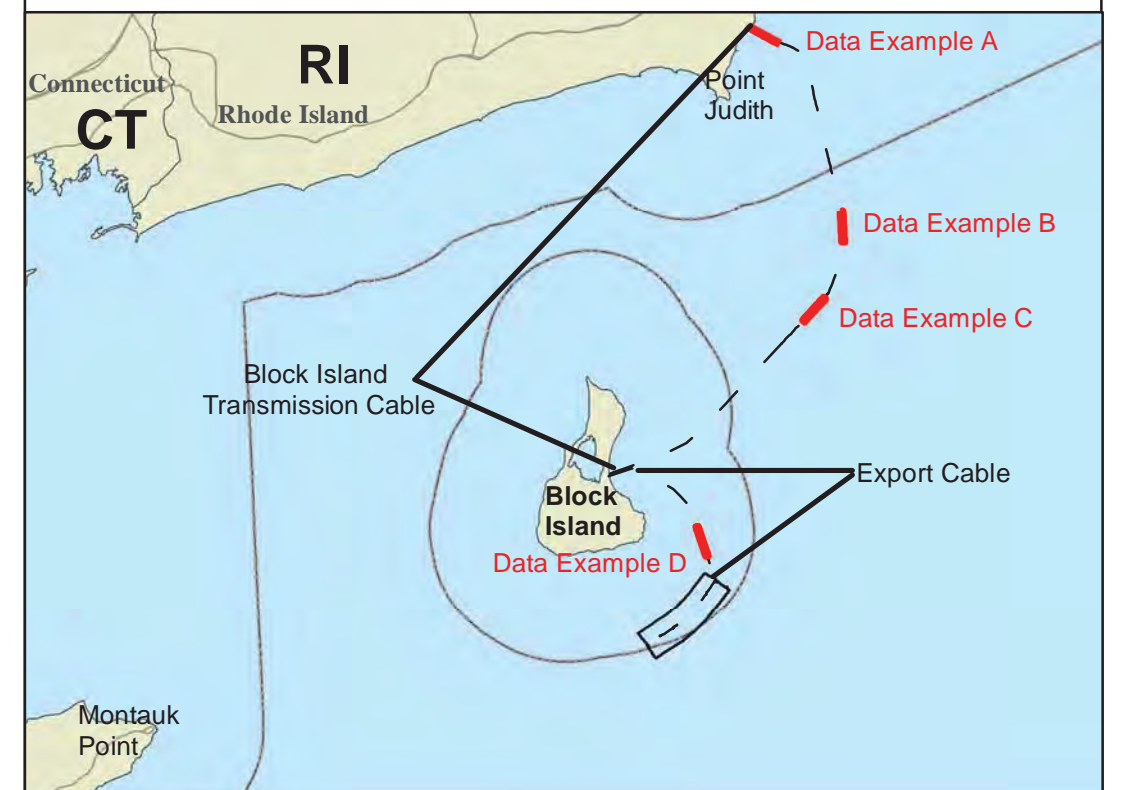

FUGRO FUGRO MARINE GEOSERVICES, INC.
 World Trade Center, Suite 350
 101 West Main Street
 Norfolk, Virginia 23510
 Tel: (757) 625-3350
 Fax: (757) 625-3352
 www.fugro.com

EXPORT CABLE/BLOCK ISLAND TRANSMISSION CABLE RECOVERY Seafloor Monitoring Study
 Block Island Wind Farm and Transmission Project
 Offshore Rhode Island

NO.	DATE:	DESCRIPTION:	DRAWN:	CHKD:	APPR:
1	Dec. 2018	Survey 5 (Dec. 2018) Report	TAW	KRS	KRS
2					
3					

JOB NUMBER: 02.81150001 CHART NO.: 7

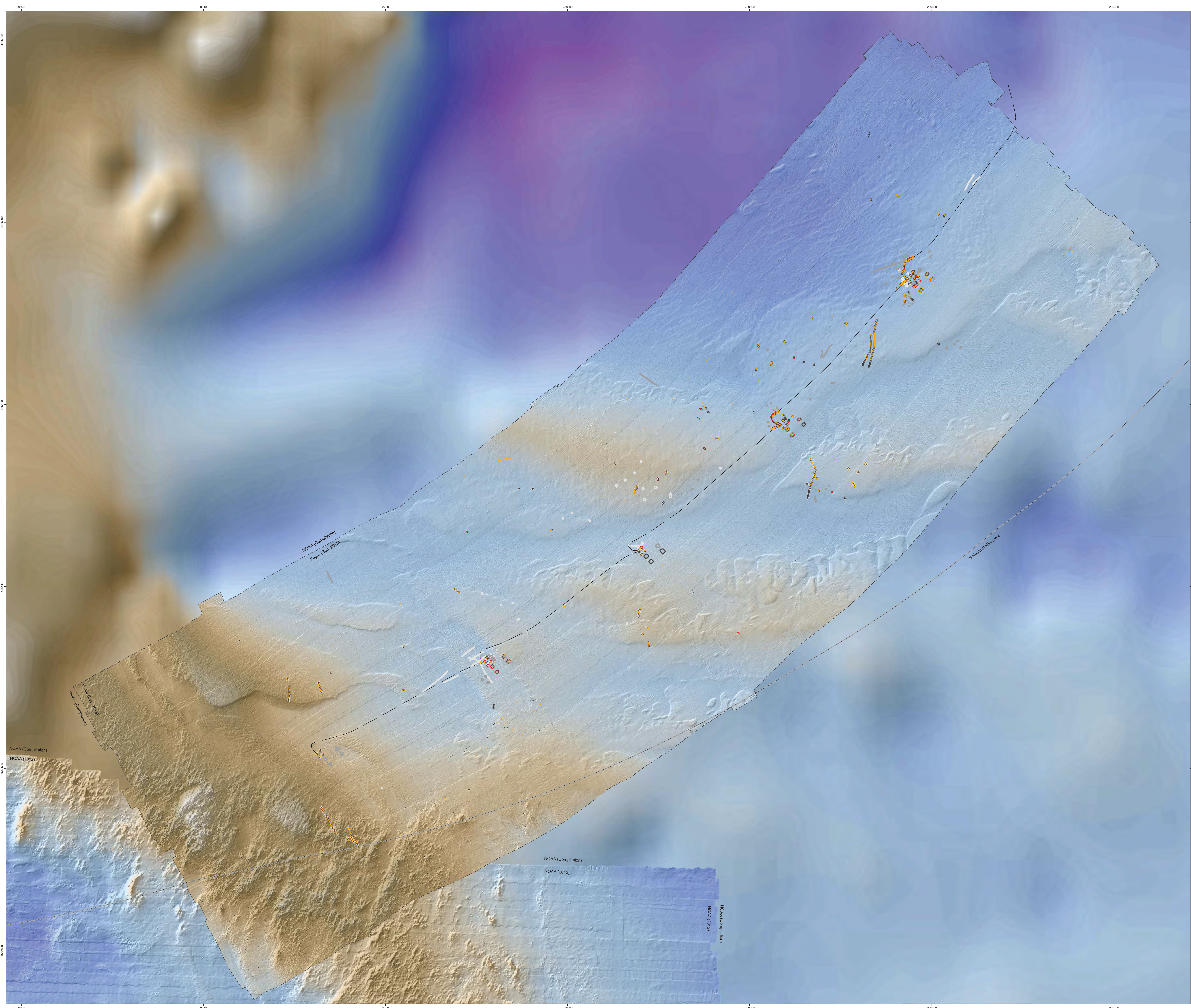

LEGEND

- Export Cable/Inter Array Cable
 - 3 Nautical Mile Limit
- Bathymetry (Meters, MLLW)**
- | | |
|-------------|-------------|
| -18.0 - -18 | -26.0 - -26 |
| -19.0 - -19 | -27.0 - -27 |
| -20.0 - -20 | -28.0 - -28 |
| -21.0 - -21 | -29.0 - -29 |
| -22.0 - -22 | -30.0 - -30 |
| -23.0 - -23 | -31.0 - -31 |
| -24.0 - -24 | -32.0 - -32 |
| -25.0 - -25 | -33.2 - -33 |
- Interpreted Seafloor Disturbance Features**
- Construction Season 1 (Survey 1-May 2016)
 - Construction Season 2 (Survey 2-Oct. 2016)
 - Survey 3 (May 2017)
 - Survey 4 (Oct. 2017)
 - Survey 5 (Sep. 2018)

Notes:

- Fugro marine survey data were collected on September 29 and 30, 2018 onboard the R/V Westley using a high-resolution integrated multibeam bathymetric survey system.
- Differential Global Positioning System (DGPS) corrections were obtained from Fugro's Omnistar GNSS in real-time via a G2 subscription.
- Survey equipment utilized for data collection included the following systems:
 - Shoos Seafloor 7120 302 Multibeam Echo-sounder (MBES)
 - Ashtech POS MV 320 (4th Mission Reference Unit & Positioning System)
 - Applied Microplane Limited (AML) SonarPro for Sound Velocity Profiles
 - FPP's WinFrog (3.10.48) navigation and data acquisition software
- NOAA (2012) Multibeam bathymetric data is from the National Oceanic and Atmospheric Administration's (NOAA) hydrographic survey of Block Island Sound, New York. This survey was conducted August 25 through August 28, 2012.
- NOAA Compiled Bathymetric data is a compilation of NOAA sounding files in the area that were collected between 1938 to 1979.

This document may only be used for the purposes for which it was commissioned and in accordance with the terms of engagement for that commission. Unauthorized use of this document in any form whatsoever is prohibited and is illegal under applicable law.

GEODEIC INFORMATION

SPHEROID: GRS 1980
 SEMI-MAJOR AXIS: 6,378,137.000000
 SEMI-MINOR AXIS: 6,356,752.314141
 EPOCH: 1982.0
 ELLIPSOIDAL FLATTENING: 298.257222101
 ECCENTRICITY^2: 0.006898000000000000
 PROJECTION: UNIVERSAL TRANSVERSE MERCATOR
 ZONE: 18N
 FALSE EASTING: 500000
 FALSE NORTHING: 0
 FALSE SCALE: 1.000000
 FALSE MERIDIAN: 0

Coordinate Grid is UTM Zone 18N
 NAD 1983, Meters

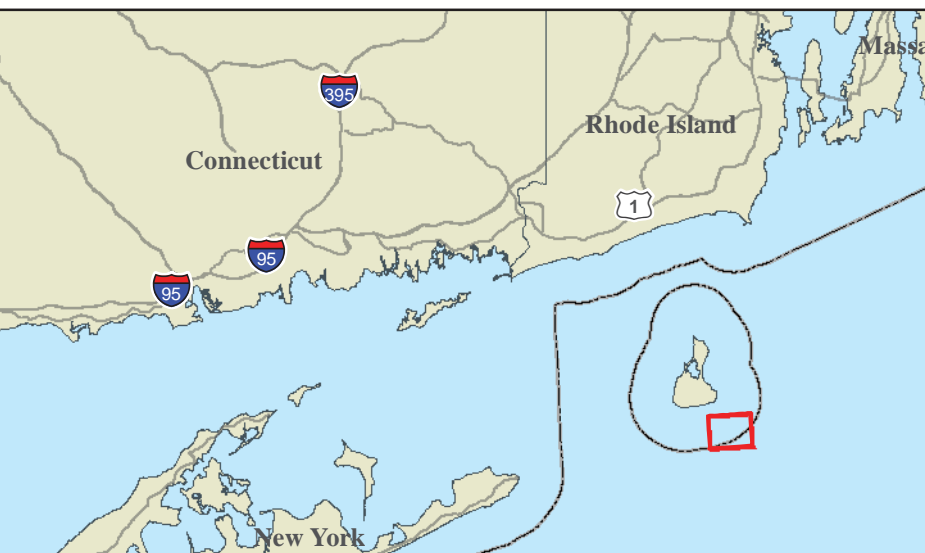

FUGRO FUGRO MARINE GEOSERVICES, INC.
 World Trade Center, Suite 350
 101 Water Main Street
 Norfolk, Virginia 23510
 Tel: (757) 625-3362
 Fax: (757) 625-3362
 www.fugro.com

INTERPRETED SEAFLOOR DISTURBANCE FEATURES PER SURVEY
 Seafloor Monitoring Study
 Block Island Wind Farm and Transmission Project
 Offshore Rhode Island

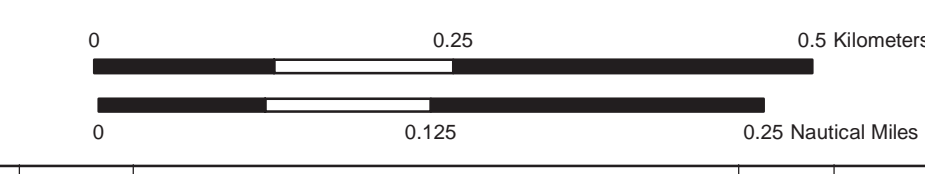

NO.	DATE	DESCRIPTION	DRAWN	CHKD	APPR
1	Dec. 2016	Survey 5 (Dec. 2016) Report	TAW	WBC	KRS
2					
3					

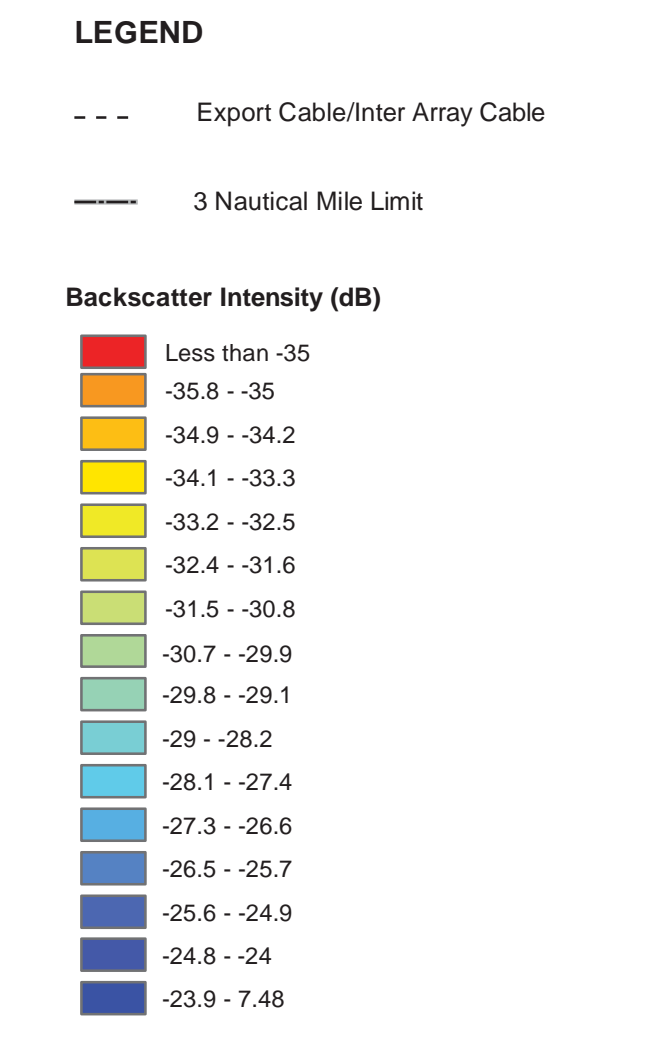
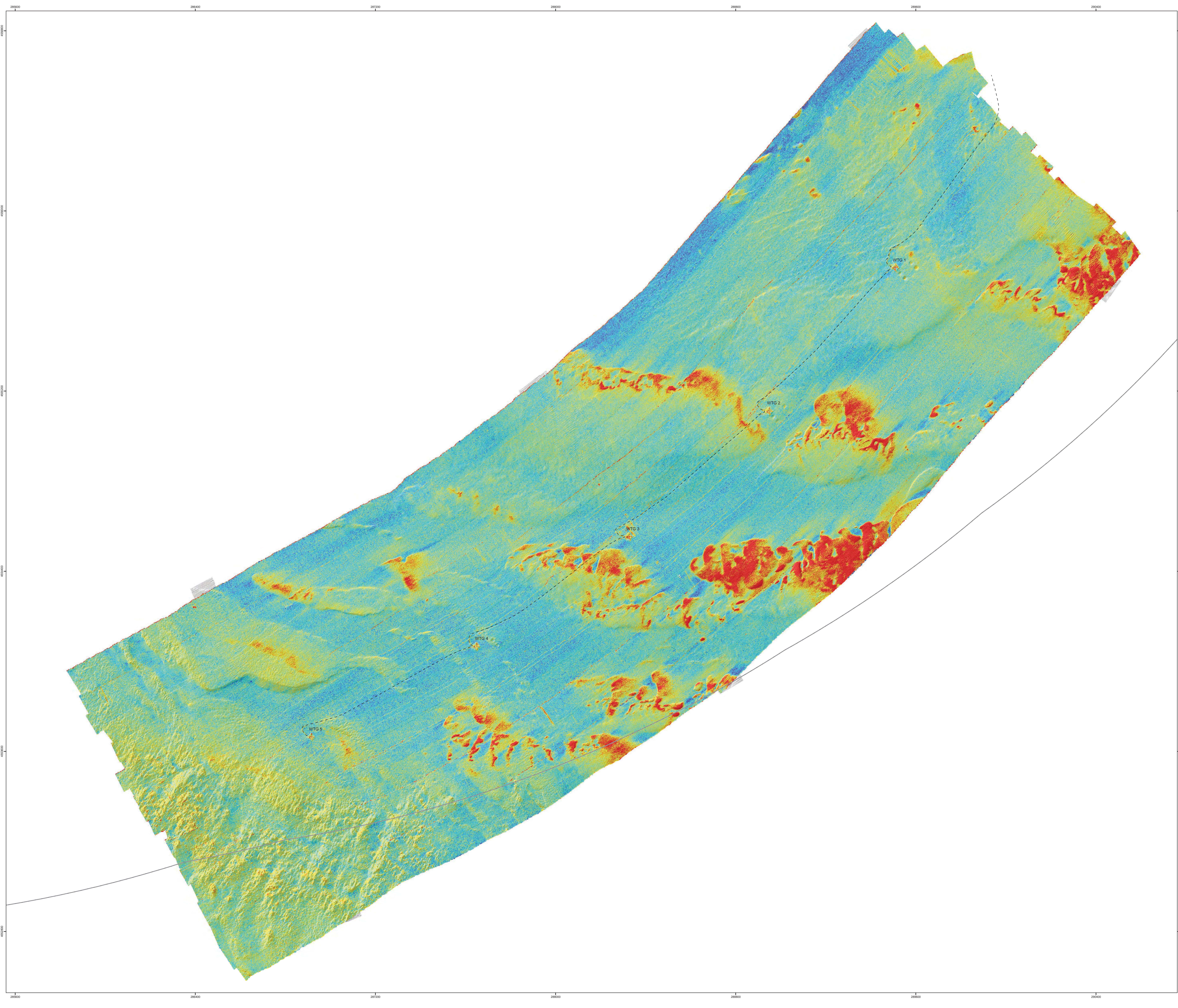

Notes:

1. Fugro marine survey data were collected on September 28 and 30, 2018 onboard the R/V Waverly using a high-resolution integrated multibeam bathymetric survey system.
2. Differential Global Positioning System (DGPS) corrections were obtained from Fugro's ChirixStar GNSS in real-time via a G2 subscription.
3. Survey equipment utilized for data collection included the following systems:
 - Shoek Seafloor 7120 302 Multibeam Echo-sounder (MBES);
 - Applan POS MV 320 (4-B Motion Reference Unit & Positioning System)
 - Applied MicroSystems Limited (AML) SonarPro for Seacat Velocity Profiles
 - FPP's WinFrog (3.3.10.48) navigation and data acquisition software

This document may only be used for the purposes for which it was commissioned and in accordance with the terms of engagement for that commission. Unauthorized use of this document in any form whatsoever is prohibited and is illegal.

GEODEIC INFORMATION

SPHEROID:	GRS 1980
SEMI-MAJOR AXIS:	6,378,137.0000
SEMI-MINOR AXIS:	6,356,752.3141
FLATTENING:	298.257222101
ECCENTRICITY ² :	0.006803411794
PROJECTION:	UNIVERSAL TRANSVERSE MERCATOR
ZONE:	ZONE 18 NORTH
LONGITUDE OF ORIGIN:	00.000
FALSE EASTING:	500,000
FALSE NORTHING:	0

Coordinate Grid is UTM Zone 18N, NAD 1983, Meters

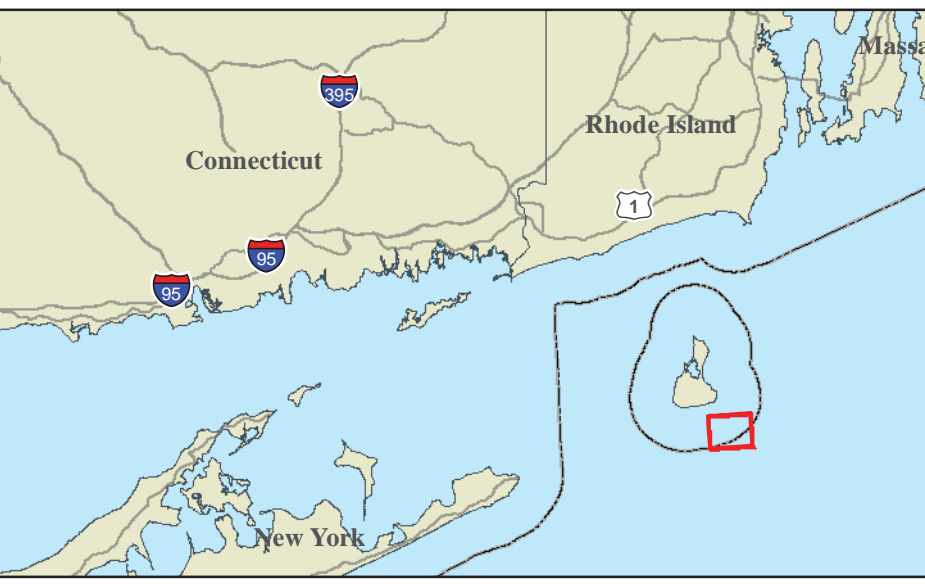

FUGRO FUGRO MARINE GEOSERVICES, INC.
 World Trade Center, Suite 350
 107 Water Main Street
 Norfolk, Virginia 23510
 Tel: (757) 625-3362
 Fax: (757) 625-3362
 www.fugro.com

SURVEY 5 (SEPTEMBER 2018)
MBES BACKSCATTER
 Seafloor Monitoring Study
 Block Island Wind Farm and Transmission Project
 Offshore Rhode Island

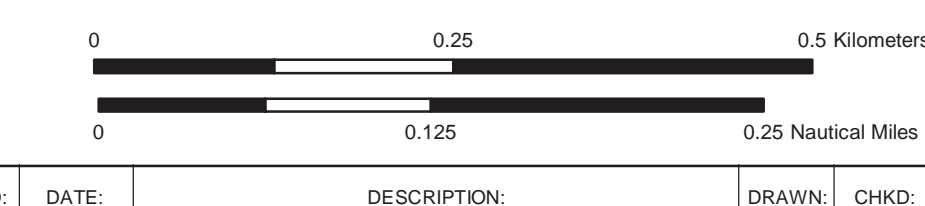

NO.	DATE	DESCRIPTION	DRAWN	CHKD	APPR.
1	Dec. 2017	Survey 5 (Dec. 2018) Report	TAW	WBC	KRS
2					
3					

A. BATHYMETRIC SURVEY VESSEL SPECIFICATIONS



A. SURVEY ACQUISITION AND PROCESSING

Fugro Marine GeoServices, Inc., Fugro, was contracted by HDR to perform a bathymetric survey of the Block Island Wind Farm. Survey operations were carried out on October 2 and 3, 2017. Multibeam bathymetry was acquired to provide current sounding data for the area in the vicinity of the wind turbines.

Data were acquired using a high-resolution integrated multibeam bathymetric survey system. The water depths surveyed ranged from approximately 20 to 32 meters in the wind farm area, based on the charted datum of Mean Lower Low Water (MLLW).

A.1 DATA ACQUISITION

A.1.1 Vessel

The *R/V Westerly*, a 50-foot survey vessel, was used for the project. The vessel was equipped with the following primary equipment for execution of the survey:

- Two R2Sonic Sonic 2024 Multibeam Echosounders (MBES)
- Applanix POS MV 320 (v4) Motion Reference Unit & Positioning System
- Applied Microsystems Limited (AML) SmartProbe, for Sound Velocity Profiles
- FPI's WinFrog (v3.10.49) navigation and data acquisition software.

A.1.2 GPS Vessel Positioning

Primary positioning data was provided by the POS MV 320 system. Position was determined in real time using a Trimble Zephyr L1/L2 GPS antenna, which was connected to a Trimble BD960 L1/L2 GPS card residing in the POS MV. An Inertial Measurement Unit (IMU) provided velocity values to the POS MV allowing it to compute an inertial position based on Differential GPS (DGPS), heading, and motion.

The POS MV was configured to accept differential corrections in the WGS84 (g1150) reference frame, received from Fugro's OmniStar GNSS subscription.

The POS MV controller software's real-time QC displays were monitored throughout the survey to ensure positional accuracies stayed within industry standards. These displays include, but are not limited to GPS Status, Position Accuracy, Receiver Status (which included HDOP), and Satellite Status.

WinFrog (v. 3.10.49) navigation software, running on a Windows 7-based PC, was used for vessel navigation. WinFrog presented vessel position data in graphical and tabular format for QC purposes. The following display windows were used:

- Graphics – the Graphics window showed an overview of navigation, including vessel position and orientation, survey lines, background plots, charts, and waypoints.
- Vehicle – the Vehicle window was configured to show tabular navigation information. This window displayed position, time, line name, heading, course over ground, speed, and data/event status.



A.1.3 Project Datum

All bathymetry was processed in WGS84 (g1150). The data were projected in Universal Transverse Mercator (UTM), zone 19 North.

TABLE 1 – PROJECT DATUM

Datum	WGS 1984 (g1150)
Ellipsoid/ Spheroid	WGS 1984
Semi-Major Axis	6378137.00 m
Semi-Minor Axis	6356752.314245179 m
Inverse Flattening (1/f)	298.257223563
Projection	UTM
Zone	19 North
Unit	Meters
Latitude of Origin	0.0°
Central Meridian (CM)	-69.0°
False Easting	500,000 m
False Northing	0 m
Scale Factor	0.9996

A.1.4 Vertical Datum

Bathymetric data were reduced to MLLW based on tidal data from NOAA’s predicted tide data for Block Island (predicted tide gauge #8459338). Predicted tides do not account for local effects, such as weather. Thus, predicted tides are rarely accurate enough for IHO Order 1a survey. To correct the tide model inaccuracies, the variance between the predicted tide data and the observed tide data from tide gauges in the region was used to adjust the predicted tide data from gauge 8459338. In this way, the predicted tide model was shifted to a pseudo-observed tide model that better accounted for local effects, such as weather.

A.1.5 Motion Sensor and Vessel Heading

A POS MV 320 motion sensor system measured the vessel’s dynamic motion and orientation (heave, pitch, roll and heading). The system consists of an inertial motion unit (IMU), two GPS receivers, and a processing unit.

The IMU uses a series of linear accelerometers and angular rate sensors that work in tandem to determine vessel attitude solutions. The combined GPS solution of each antenna is used to calculate the orientation and heading of the vessel. Offsets for the IMU and GPS antenna are presented in the vessel offset diagram in Figure A-1.

Motion, heading, and position data were sent to WinFrog for navigation and data logging purposes during MBES acquisition.

A.1.6 Sound-Velocity Profiles

Sound-velocity profile (SVP) data were acquired using an Applied Microsystems Ltd. (AML) Smart Probe. The AML Smart probe measures at a maximum rate of 10 velocity and pressure observations per second. For each cast, the probe was held at the surface for approximately two minutes to reach temperature equilibrium. The probes were then manually lowered at the rate of about 1 m/s to the seafloor and raised to the surface at the same rate.

Sound-velocity casts were conducted regularly to ensure MBES data could be corrected for refraction. Casts were spaced geographically and temporally to create an accurate model of the sound velocity profile for the water column across the survey area.

A.1.7 Multibeam Echosounder

The *R/V Westerly* was equipped with an over-the-stern, pole-mounted dual-head R2Sonic Sonic 2024 MBES system, designed to operate between water depths of 0.5 m to 500 m. The two multibeam sonars were mounted with a 30-degree vertical offset between the port and starboard transducers. The MBES was used to collect bathymetry data over the entire area. Survey speed was kept between 4 to 7 knots to ensure low turbulence around the multibeam transducer pole.

Data received by the Sonic sonar-processing unit was sent to WinFrog, where bathymetry quality was continually monitored during acquisition. Various windows displayed a 3D bathymetry profile, sonar beam amplitude measurements, and swath coverage to allow adjustments to sonar settings or vessel speed, when appropriate. A parameter window also displayed position, speed, heading, and attitude data that was received from the POS MV 320.

WinFrog was used to start and stop data logging in .S7K file format and to name lines. Power, gain, and range settings were controlled directly through the Sonic user interface monitor and varied according to water depth and data quality. Settings were noted on the multibeam line logs, using FPI's MB Survey Tools software.

A.2 DATA PROCESSING

A.2.1 HORIZONTAL AND VERTICAL CONTROL

The real-time navigation and position data were used as the geodetic control, receiving Differential GNSS corrections in real-time via a G2 subscription to Fugro's OmniStar service.

All real-time positioning data were converted to WGS84 (g1150) in the Applanix POS MV. This real-time positioning was used to process the multibeam survey lines.

A.2.2 Vertical Control

The vertical datum for this project was from NOAA tide stations in the region, specifically adjusted tide data from NOAA's predicted tide gauge at Block Island (NOAA gauge #8459338).

A.2.3 Bathymetry

All soundings were processed using CARIS HIPS software on Windows 7 workstations. CARIS was used to process, clean, and produce Digital Terrain Models (DTM) and finalized XYZ ASCII files.

A.2.4 Corrections to Bathymetry Data

Within CARIS HIPS, Sonic 2024 SV2 soundings were corrected for calibrated patch test results, vessel offsets, vessel motion, draft, sound velocity, and tide.

A.2.5 Vessel Offsets

Offsets established during the mobilization were used to correct bathymetry for differences between the transducer head and GPS antenna position. Offsets are detailed in Figure A-1. Offsets were entered in the Vessel Configuration File in CARIS HIPS to correct the bathymetry during processing.

A.2.6 Sound Velocity Profiles

Processed sound velocity profiles were used to correct bathymetry data for sound refraction, or ray bending.

SVP's were applied within CARIS. FPI's Multibeam Survey Tools v 3.1.30 software was used to process the SVP data set, generating a smooth interpolation curve that depicted the original profile at the finest resolution available in CARIS.

A.2.7 Static Draft

Static draft observations were measured at the over-the-stern mount of the *R/V Westerly*. The correction was then applied to bring soundings from the transducer level to the water level. The static draft value was entered into the HIPS Vessel File (HVF) within CARIS HIPS. It should be noted that draft is actually distance from the common reference point (CRP) to the water level; CARIS takes into account the distance from the CRP to the transducer head in its calculations.

A.2.8 Data Cleaning

The .S7K files were converted to CARIS HIPS format for bathymetry processing. Prior to each survey line being converted from .S7K to CARIS' HIPS format, the vessel offsets, patch test calibration values and static draft measurements were entered into the HVF. The SVP file was then loaded into each line, and the line was corrected for sound refraction. During SVP correction the bathymetry was also corrected for dynamic vessel heave, pitch and roll. The attitude, heading, navigation, and bathymetry data were examined for noise and gaps. Beam filters were used to reject data from the outer beams of the swaths. It should be noted that rejection does not mean deletion from the data set; soundings were simply flagged as 'rejected' and could be re-accepted if necessary.

After each individual line was examined and cleaned in CARIS' Swath Editor (Figure A-1), the tide file was loaded, and the lines were merged. During merging, tide and draft corrections were applied. Subsets were then created in CARIS' Subset Editor mode (Figure A-2), and adjacent overlapping lines of corrected bathymetry data were examined to identify any tidal busts, sound velocity errors, motion errors, or data gaps. Any residual noise in the data set was manually rejected at this time.

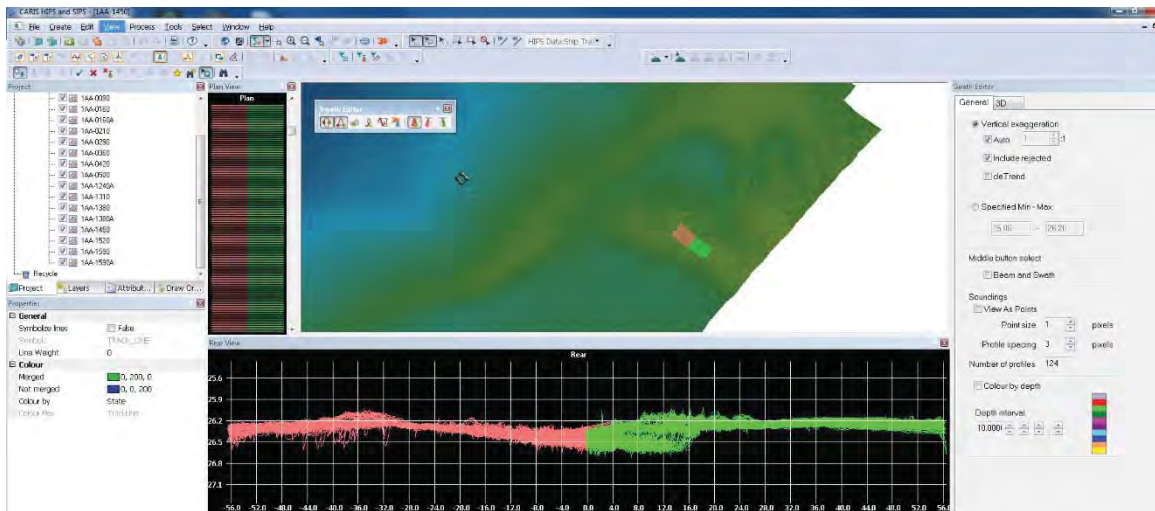

FIGURE A-1 CARIS SWATH EDITOR

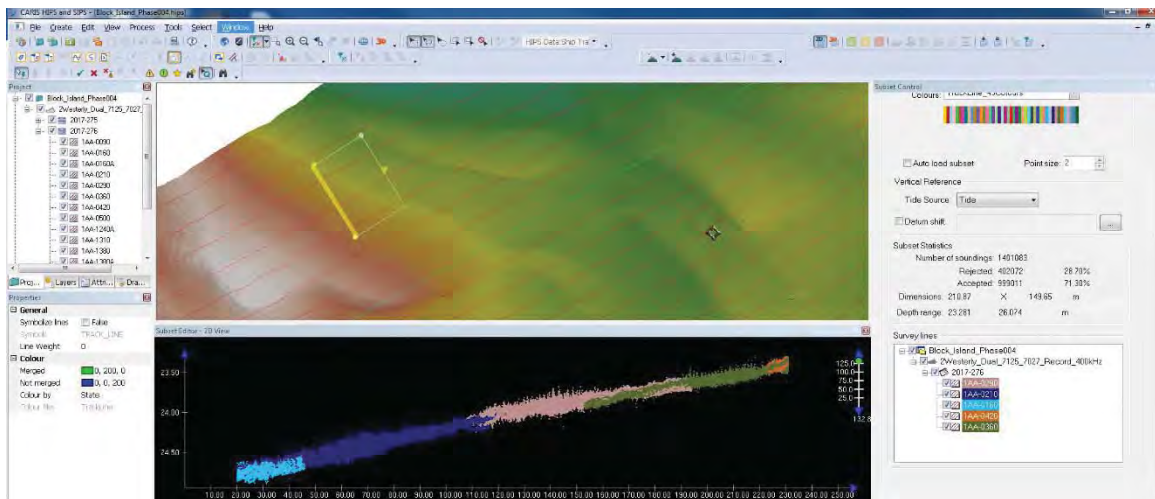

FIGURE A-2 CARIS SWATH SUBSET EDITOR

A.2.9 DTM Generation

Once all cleaning and processing was completed, a DTM was generated with CARIS' CUBE surface routine, thus depicting a mean seafloor. Final DTM grid size was 0.5 m.

Sun-illuminated images of the DTM grids were created within CARIS using the image-manager. These images were then exported as GeoTiffs.

A.2.10 XYZ Generation

CARIS HIPS was used to export the CUBE surface model to an ASCII XYZ grid of Eastings, Northings, and Depth values in meters. The XYZ file was delivered with a grid spacing of 0.5 meters by 0.5 meters.



A.3 CALIBRATIONS AND QUALITY CONTROL

During both data acquisition and processing, various calibrations and quality control (QC) measures were performed to ensure the data met the project’s accuracy specifications.

A.3.1 Vessel Offset Survey

During vessel mobilization, the offset values from the POS MV’s IMU to the sonar and GNSS antennas were obtained using total station.

A.3.2 MBES Patch Test Calibration

An MBES patch test calibration was carried out on September 29, 2018 to verify the mounting offsets between the sonar heads and motion reference unit. Each sonar head of the dual-head system was calibrated independently. A patch test uses seafloor topology to bring swaths run at varying speeds, headings, and overlaps into coincidence. Patch tests are employed to correct the data for navigation timing, pitch, roll, and azimuth offsets, which may exist between the MBES transducers and the IMU.

Patch Test values were obtained in CARIS HIPS calibration mode within the Subset Editor routine. Calculated values were then entered in the HVF to ensure all survey data would be corrected for these offsets during processing (Table 2). As the dual-head sonar system has two distinct Sonic 2024 transducers, both the port and starboard transducer required calibration during the patch test.

TABLE 2 – PATCH TEST CALIBRATION

Calibration Offset	Correction
Navigation Timing Error	0.000 s
Port Sonar Pitch Offset	-1.650°
Port Sonar Roll Offset	16.360°
Port Sonar Azimuth (Yaw) Offset	-0.650°
Starboard Sonar Pitch Offset	-1.600°
Starboard Sonar Roll Offset	-14.875°
Starboard Sonar Azimuth (Yaw) Offset	-2.050°

A.3.3 MBES Crosslines

Two crosslines were acquired during this phase of the project. Crossline quality control reports were run in CARIS HIPS software to ensure the data met IHO Order 1a specifications. This crossline analysis was used in conjunction with the total propagated uncertainty values for the data, ensuring project specifications were met. Likewise, the bathymetry from this phase of the project was compared to bathymetry from previous phases. The peaks of rocks should always align, as the rocks are not shifting on the seafloor. (Similar types of testing are less reliable over sandy seafloors due to sediment transfer causing erosion or deposition.) Thus, the combination of bathymetry comparison across different survey phases, analysis of total propagated uncertainty, and the analysis of crossline quality control reports was used to confirm that the data met IHO Order 1a specification.

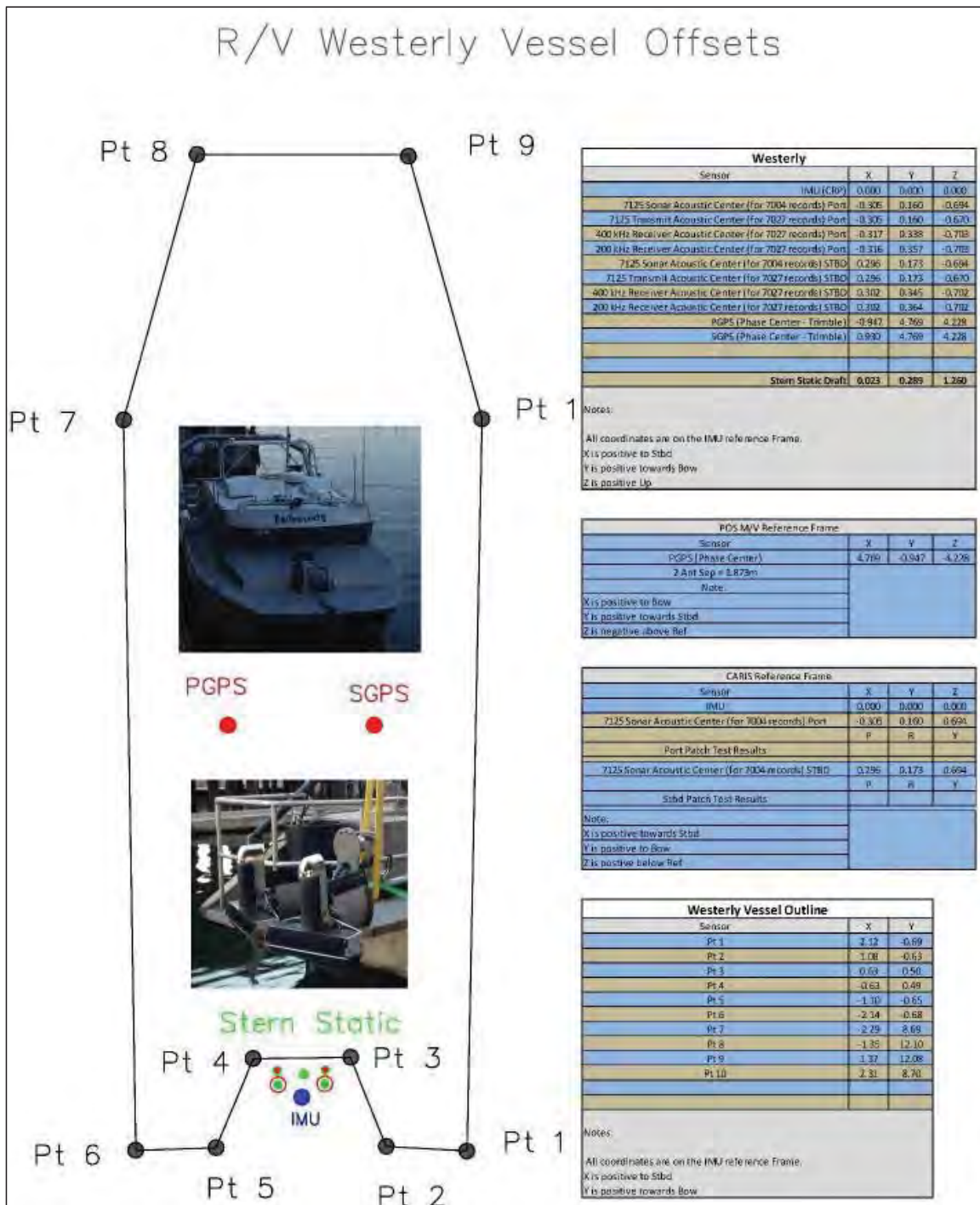

VESSEL OFFSET DIAGRAM FOR THE R/V WESTERLY
Seafloor Monitoring Study
Block Island Wind Farm and Transmission Project
Offshore Rhode Island

Figure A-3

B. INSTALLATION VESSEL SPECIFICATIONS

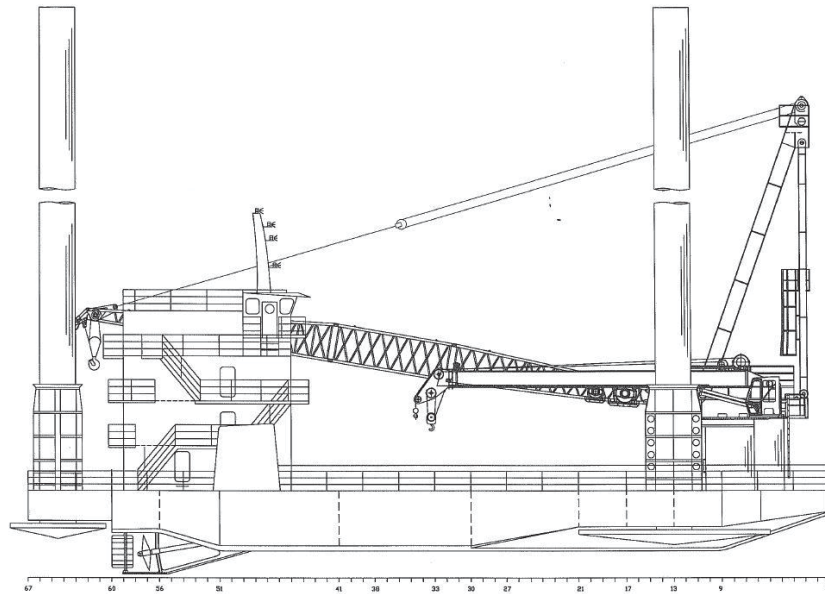

GENERAL ARRANGEMENT MAIN DECK
SCALE 3/16" = 1'-0"

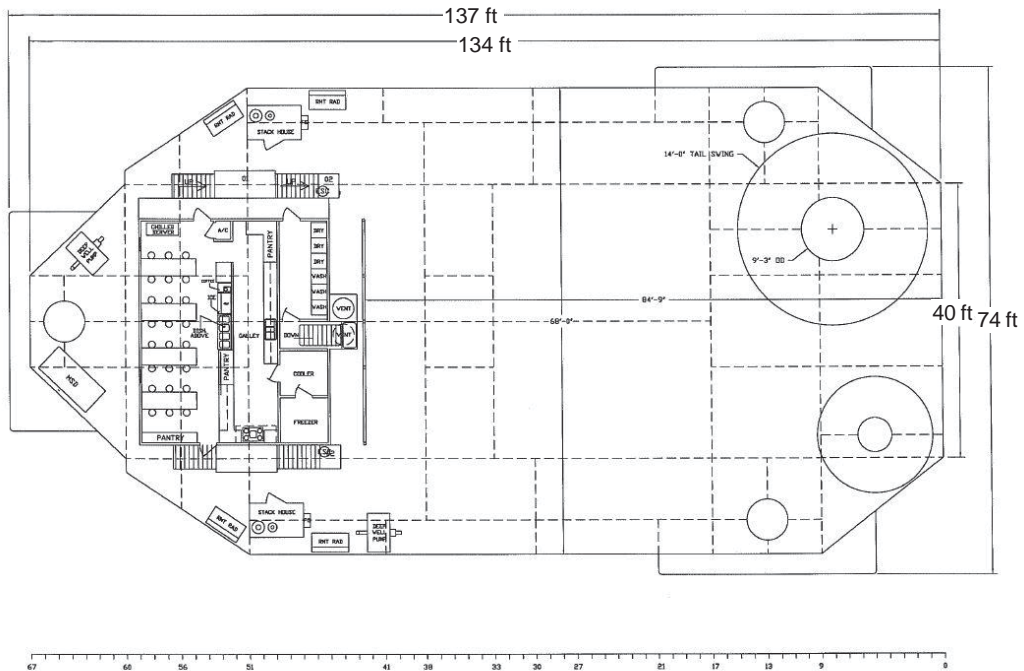

GENERAL ARRANGEMENT MAIN DECK

VESSEL SPECIFICATIONS FOR THE *L/B MICHAEL EYMARD*
Seafloor Monitoring Study
Block Island Wind Farm and Transmission Project
Offshore Rhode Island

FIGURE B-1

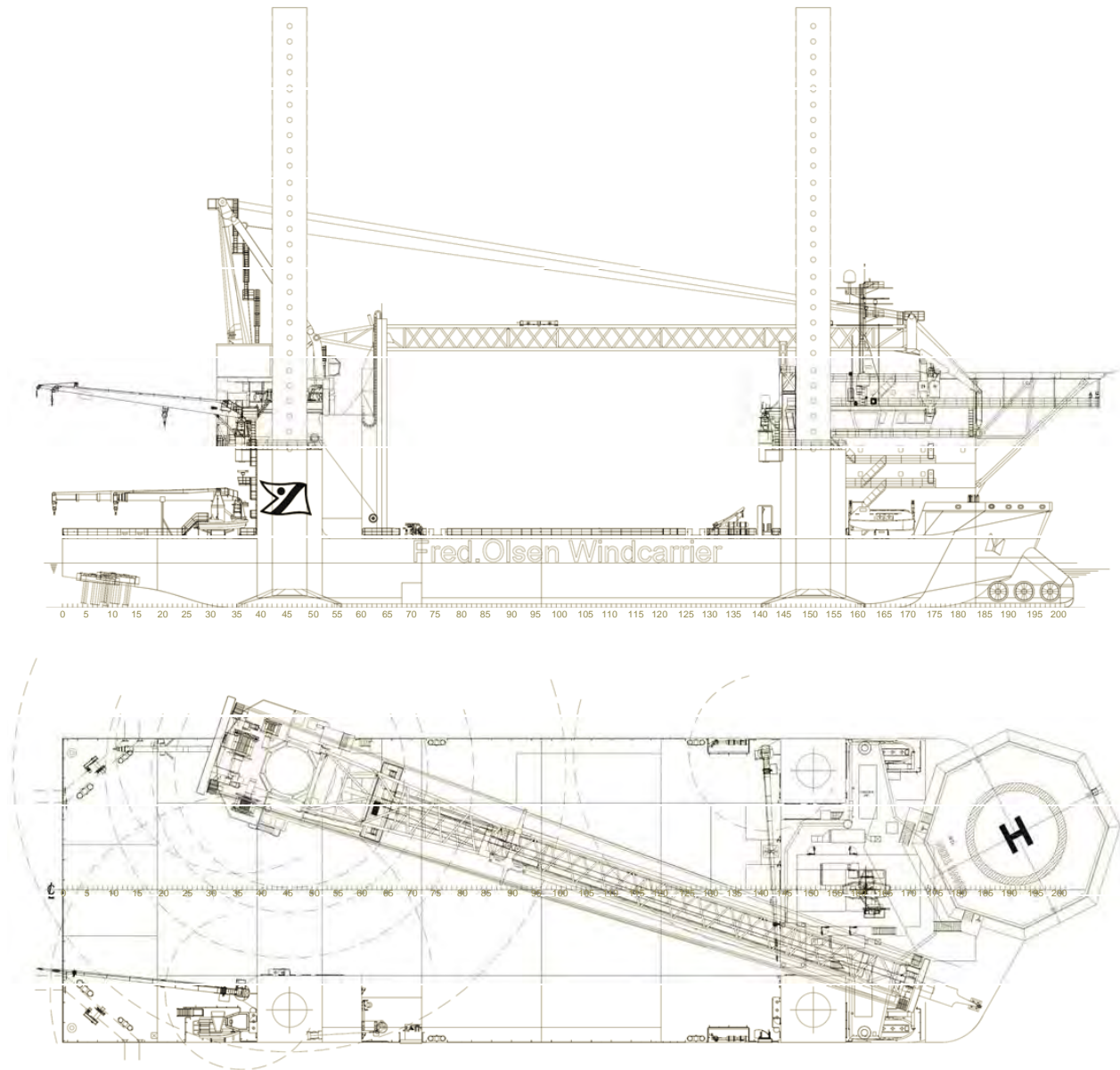

VESSEL SPECIFICATIONS FOR THE L/B *BRAVE TERN*
Seafloor Monitoring Study
Block Island Wind Farm and Transmission Project
Offshore Rhode Island

FIGURE B-2

C. CATALOG OF SEAFLOOR DISTURBANCE FEATURES

Table C-1. Seafloor Disturbance Features (Survey 5 - Sep. 2018)

Feature ID	Northing ¹ (m)	Easting ¹ (m)	Elevation ² (m)	Feature Perimeter (m)	Feature Area (m ²)	Max Depth (m)	Feature Interpretation	Attributed Vessel	Construction Season	Relative Change
F0	4554820	288297	-25.0	54	120	0.17	Drag Mark	Unknown	1	Some Change ³
F1	4554840	288306	-25.0	39	82	0.16	Drag Mark	Unknown	1	Some Change ³
F2	4554870	288395	-24.8	36	72	0.14	Drag Mark	Unknown	1	Mostly Healed
F3	4554900	288433	-24.8	37	76	0.22	Drag Mark	Unknown	1	Little Change
F4	4554770	288418	-25.4	33	59	0.17	Drag Mark	Unknown	1	Mostly Healed
F5	4555020	288625	-25.4	49	108	0.13	Drag Mark	Unknown	1	Mostly Healed
F6	4555470	289343	-27.0	441	983	0.12	Drag Mark	Unknown	1	Some Change ³
F7	4555440	289322	-26.9	310	603	0.11	Drag Mark	Unknown	1	Some Change ³
F8	4554860	289072	-26.2	380	595	0.15	Drag Mark	Unknown	1	Some Change ³
F9	4554290	288314	-24.4	86	205	0.13	Drag Mark	Unknown	1	Some Change ³
F10	4554150	288357	-25.1	54	97	0.11	Drag Mark	Unknown	1	Little Change

Notes: See Charts 3, 4, 5, and 6 for the location of each seafloor disturbance feature.

¹ UTM Zone 19, NAD83, Meter

² Elevation represents centroid location of the feature.

³ Change was infilling of feature.

⁴ Change was deepening of feature.

Feature ID	Northing ¹ (m)	Easting ¹ (m)	Elevation ² (m)	Feature Perimeter (m)	Feature Area (m ²)	Max Depth (m)	Feature Interpretation	Attributed Vessel	Construction Season	Relative Change
F11	4554320	287986	-25.6	30	59	0.25	Circular Depression	Unknown	1	Some Change ³
F12	4554260	287784	-25.7	25	38	0.13	Circular Depression	Unknown	1	Mostly Healed
F13	4554370	287624	-26.2	19	24	0.09	Circular Depression	Unknown	1	Mostly Healed
F14	4553940	287279	-25.4	23	34	0.13	Circular Depression	Unknown	1	Little Change
F15	4553960	286913	-23.5	95	155	0.12	Drag Mark	Unknown	1	Some Change ³
F16	4555050	288655	-25.7	35	74	0.2	Drag Mark	Unknown	1	Some Change ³
F17	4555010	288601	-25.3	26	42	0.15	Circular Depression	Unknown	1	Mostly Healed
F18	4555000	288653	-25.4	23	34	0.09	Circular Depression	Unknown	1	Mostly Healed
F19	4555080	288665	-25.9	22	35	0.07	Circular Depression	Unknown	1	Mostly Healed
F20	4555140	288574	-26.3	33	69	0.14	Circular Depression	Unknown	1	Little Change
F21	4555180	288585	-26.7	30	48	0.18	Drag Mark	Unknown	1	Mostly Healed
F22	4555190	288606	-26.7	37	56	0.12	Drag Mark	Unknown	1	Little Change
F23	4555210	288597	-27.0	24	31	0.13	Drag Mark	Unknown	1	Mostly Healed

Notes: See Charts 3, 4, 5, and 6 for the location of each seafloor disturbance feature.

¹ UTM Zone 19, NAD83, Meter

² Elevation represents centroid location of the feature.

³ Change was infilling of feature.

⁴ Change was deepening of feature.

Feature ID	Northing ¹ (m)	Easting ¹ (m)	Elevation ² (m)	Feature Perimeter (m)	Feature Area (m ²)	Max Depth (m)	Feature Interpretation	Attributed Vessel	Construction Season	Relative Change
F24	4554850	289258	-26.0	50	73	0.16	Drag Mark	Unknown	1	Some Change ³
F25	4555940	289623	-28.0	60	151	0.09	Drag Mark	Unknown	1	Mostly Healed
F26	4556030	289655	-28.1	29	51	0.08	Circular Depression	Unknown	1	Little Change
F27	4556030	289632	-28.1	30	53	0.08	Circular Depression	Unknown	1	Little Change
F28	4556120	289641	-28.2	26	41	0.1	Circular Depression	Unknown	1	Mostly Healed
F29	4556140	289665	-28.3	28	54	0.19	Circular Depression	Unknown	1	Mostly Healed
F30	4556100	289334	-29.6	27	51	0.07	Circular Depression	Unknown	1	Some Change ³
F31	4556120	289449	-29.0	35	74	0.11	Circular Depression	Unknown	1	Little Change
F32	4556120	289535	-28.8	19	26	0.05	Circular Depression	Unknown	1	Mostly Healed
F33	4556100	289519	-28.7	31	56	0.1	Circular Depression	Unknown	1	Mostly Healed
F34	4553360	286958	-22.0	195	247	0.2	Drag Mark	Unknown	1	Little Change
F35	4553420	286922	-21.8	52	70	0.1	Drag Mark	Unknown	1	Little Change
F36	4553310	287048	-21.7	146	222	0.16	Drag Mark	Unknown	1	Little Change

Notes: See Charts 3, 4, 5, and 6 for the location of each seafloor disturbance feature.

¹ UTM Zone 19, NAD83, Meter

² Elevation represents centroid location of the feature.

³ Change was infilling of feature.

⁴ Change was deepening of feature.

Feature ID	Northing ¹ (m)	Easting ¹ (m)	Elevation ² (m)	Feature Perimeter (m)	Feature Area (m ²)	Max Depth (m)	Feature Interpretation	Attributed Vessel	Construction Season	Relative Change
F37	4554690	288094	-26.3	18	22	0.1	Circular Depression	Unknown	1	Mostly Healed
F38	4554690	288098	-26.3	15	14	0.06	Circular Depression	Unknown	1	Mostly Healed
F39	4554720	288019	-26.4	20	28	0.14	Circular Depression	Unknown	1	Mostly Healed
F40	4554700	287980	-26.4	19	24	0.06	Circular Depression	Unknown	1	Mostly Healed
F41	4554830	287787	-26.8	12	11	0.1	Circular Depression	Unknown	1	Mostly Healed
F42	4554830	287846	-26.6	18	23	0.14	Circular Depression	Unknown	1	Mostly Healed
F43	4555370	289084	-27.2	25	44	0.09	Circular Depression	Unknown	1	Some Change ³
F44	4555390	289036	-27.5	21	32	0.07	Circular Depression	Unknown	1	Mostly Healed
F45	4555380	288895	-28.0	52	80	0.13	Drag Mark	Unknown	1	Little Change
F46	4555350	288826	-28.1	25	43	0.08	Circular Depression	Unknown	1	Little Change
F47	4555380	288829	-28.2	26	50	0.06	Circular Depression	Unknown	1	Mostly Healed
F48	4555460	288838	-28.5	37	76	0.07	Circular Depression	Unknown	1	Little Change
F49	4555410	288995	-27.7	28	46	0.08	Circular Depression	Unknown	1	Mostly Healed

Notes: See Charts 3, 4, 5, and 6 for the location of each seafloor disturbance feature.

¹ UTM Zone 19, NAD83, Meter

² Elevation represents centroid location of the feature.

³ Change was infilling of feature.

⁴ Change was deepening of feature.

Feature ID	Northing ¹ (m)	Easting ¹ (m)	Elevation ² (m)	Feature Perimeter (m)	Feature Area (m ²)	Max Depth (m)	Feature Interpretation	Attributed Vessel	Construction Season	Relative Change
F50	4555470	288954	-28.0	32	59	0.1	Circular Depression	Unknown	1	Little Change
F51	4555450	288905	-28.2	18	22	0.05	Circular Depression	Unknown	1	Mostly Healed
F52	4555340	289077	-27.2	33	49	0.08	Circular Depression	Unknown	1	Mostly Healed
F53	4555380	289154	-27.1	18	24	0.06	Circular Depression	Unknown	1	Mostly Healed
F54	4555470	289071	-27.8	25	43	0.09	Circular Depression	Unknown	1	Mostly Healed
F55	4555580	289074	-28.4	21	26	0.09	Circular Depression	Unknown	1	Little Change
F56	4555560	289223	-27.8	32	67	0.18	Circular Depression	Unknown	1	Some Change ³
F57	4555600	289430	-27.9	22	34	0.12	Circular Depression	Unknown	1	Mostly Healed
F58	4555420	289304	-26.8	32	76	0.17	Circular Depression	Unknown	1	Mostly Healed
F59	4555450	289541	-26.5	28	52	0.13	Circular Depression	Unknown	1	Mostly Healed
F60	4555420	289514	-26.5	29	47	0.08	Circular Depression	Unknown	1	Mostly Healed
F61	4555420	289533	-26.5	17	21	0.03	Circular Depression	Unknown	1	Mostly Healed
F62	4555470	289629	-26.5	25	44	0.08	Circular Depression	Unknown	1	Mostly Healed

Notes: See Charts 3, 4, 5, and 6 for the location of each seafloor disturbance feature.

¹ UTM Zone 19, NAD83, Meter

² Elevation represents centroid location of the feature.

³ Change was infilling of feature.

⁴ Change was deepening of feature.

Feature ID	Northing ¹ (m)	Easting ¹ (m)	Elevation ² (m)	Feature Perimeter (m)	Feature Area (m ²)	Max Depth (m)	Feature Interpretation	Attributed Vessel	Construction Season	Relative Change
F63	4555620	289412	-28.1	15	16	0.06	Circular Depression	Unknown	1	Mostly Healed
F64	4554900	289275	-25.7	27	46	0.11	Circular Depression	Unknown	1	Little Change
F65	4554940	289309	-25.6	33	78	0.09	Circular Depression	Unknown	1	Some Change ³
F66	4554920	289234	-25.7	23	38	0.06	Circular Depression	Unknown	1	Some Change ³
F67	4554850	289053	-26.4	23	37	0.14	Circular Depression	Unknown	1	Some Change ³
F68	4554820	289105	-27.0	24	38	0.2	Circular Depression	Unknown	1	Some Change ³
F69	4554950	288323	-24.3	28	57	0.1	Circular Depression	Unknown	1	Mostly Healed
F70	4554900	288294	-24.4	24	35	0.1	Circular Depression	Unknown	1	Mostly Healed
F71	4554870	288253	-24.6	25	42	0.06	Circular Depression	Unknown	1	Mostly Healed
F72	4554830	288332	-25.0	27	51	0.11	Circular Depression	Unknown	1	Mostly Healed
F73	4554190	288330	-24.6	21	31	0.07	Circular Depression	Unknown	1	Little Change
F74	4554220	288352	-24.4	24	41	0.05	Circular Depression	Unknown	1	Some Change ³
F75	4554800	288452	-25.4	43	106	0.09	Drag Mark	Unknown	1	Mostly Healed

Notes: See Charts 3, 4, 5, and 6 for the location of each seafloor disturbance feature.

¹ UTM Zone 19, NAD83, Meter

² Elevation represents centroid location of the feature.

³ Change was infilling of feature.

⁴ Change was deepening of feature.

Feature ID	Northing ¹ (m)	Easting ¹ (m)	Elevation ² (m)	Feature Perimeter (m)	Feature Area (m ²)	Max Depth (m)	Feature Interpretation	Attributed Vessel	Construction Season	Relative Change
F76	4555080	288517	-25.6	41	64	0.25	Drag Mark	Unknown	1	Mostly Healed
F77	4555740	289474	-28.1	64	89	0.07	Drag Mark	Unknown	1	Mostly Healed
F78	4554100	287659	-26.2	70	135	0.22	Scour	Unknown	1	Mostly Healed
F79	4555170	288618	-26.6	24	38	0.08	Circular Depression	Unknown	1	Mostly Healed
F80	4554590	288327	-26.2	17	19	0.07	Circular Depression	Unknown	1	Mostly Healed
F81	4554090	287646	-26.0	36	79	0.08	Scour	Unknown	1	Little Change
F82	4555740	289545	-27.8	33	80	0.1	Spud	L/B Robert	1	Little Change
F83	4555050	288622	-25.7	27	51	0.05	Circular Depression	Unknown	1	Mostly Healed
F84	4554920	288672	-25.6	25	45	0.05	Circular Depression	Unknown	1	Mostly Healed
F85	4554240	288261	-24.9	24	36	0.06	Circular Depression	Unknown	1	Mostly Healed
F86	4554790	289218	-26.7	22	32	0.08	Circular Depression	Unknown	1	Mostly Healed
F87	4554780	288338	-25.3	33	82	0.09	Circular Depression	Unknown	1	Mostly Healed
F88	4554830	288386	-24.8	31	68	0.05	Circular Depression	Unknown	1	Mostly Healed

Notes: See Charts 3, 4, 5, and 6 for the location of each seafloor disturbance feature.

¹ UTM Zone 19, NAD83, Meter

² Elevation represents centroid location of the feature.

³ Change was infilling of feature.

⁴ Change was deepening of feature.

Feature ID	Northing ¹ (m)	Easting ¹ (m)	Elevation ² (m)	Feature Perimeter (m)	Feature Area (m ²)	Max Depth (m)	Feature Interpretation	Attributed Vessel	Construction Season	Relative Change
F89	4554540	288325	-23.8	27	53	0.08	Scour	Unknown	1	Little Change
F90	4554840	288214	-25.0	33	69	0.08	Circular Depression	Unknown	1	Mostly Healed
F91	4553920	286779	-22.0	23	39	0.12	Circular Depression	Unknown	1	Little Change
F92	4555700	289557	-27.5	25	47	0.12	Spud	L/B Robert	1	Mostly Healed
F93	4554590	288330	-26.3	22	32	0.07	Circular Depression	Unknown	1	Mostly Healed
F94	4554560	288311	-26.1	31	71	0.06	Scour	Unknown	1	Little Change
F95	4555760	289539	-27.8	37	99	0.13	Spud	L/B Robert	1	Mostly Healed
F96	4555720	289520	-27.9	28	56	0.16	Spud	L/B Robert	1	Some Change ⁴
F97	4555780	289517	-28.0	36	94	0.16	Spud	L/B Robert	1	Little Change
F98	4555750	289472	-28.2	24	43	0.15	Spud	L/B Robert	1	Mostly Healed
F99	4555790	289456	-28.4	21	32	0.19	Spud	L/B Robert	1	Mostly Healed
F100	4555770	289493	-28.2	27	51	0.11	Spud	L/B Robert	1	Mostly Healed

∞

Notes: See Charts 3, 4, 5, and 6 for the location of each seafloor disturbance feature.

¹ UTM Zone 19, NAD83, Meter

² Elevation represents centroid location of the feature.

³ Change was infilling of feature.

⁴ Change was deepening of feature.

Feature ID	Northing ¹ (m)	Easting ¹ (m)	Elevation ² (m)	Feature Perimeter (m)	Feature Area (m ²)	Max Depth (m)	Feature Interpretation	Attributed Vessel	Construction Season	Relative Change
F101	4555730	289481	-28.3	32	62	0.38	Spud	L/B Michael Eymard	1	Mostly Healed
F102	4555130	288971	-26.8	21	30	0.1	Spud	L/B Robert	1	Mostly Healed
F103	4555720	289486	-28.1	17	19	0.15	Spud	L/B Michael Eymard	1	Mostly Healed
F104	4555720	289495	-28.2	18	19	0.33	Spud	L/B Michael Eymard	1	Mostly Healed
F105	4555730	289499	-28.1	17	17	0.20	Spud	L/B Michael Eymard	1	Mostly Healed
F106	4555730	289491	-28.3	14	12	0.20	Spud	L/B Michael Eymard	1	Mostly Healed
F107	4555730	289488	-28.2	19	21	0.20	Spud	L/B Michael Eymard	1	Mostly Healed
F108	4555700	289477	-28.0	19	21	0.14	Spud	L/B Michael Eymard	1	Mostly Healed
F109	4555700	289470	-28.1	19	19	0.15	Spud	L/B Michael Eymard	1	Mostly Healed

Notes: See Charts 3, 4, 5, and 6 for the location of each seafloor disturbance feature.

¹ UTM Zone 19, NAD83, Meter

² Elevation represents centroid location of the feature.

³ Change was infilling of feature.

⁴ Change was deepening of feature.

Feature ID	Northing ¹ (m)	Easting ¹ (m)	Elevation ² (m)	Feature Perimeter (m)	Feature Area (m ²)	Max Depth (m)	Feature Interpretation	Attributed Vessel	Construction Season	Relative Change
F110	4555130	288947	-26.7	28	55	0.06	Scour	Unknown	1	Little Change
F111	4555150	288948	-26.8	21	34	0.1	Spud	L/B Robert	1	Little Change
F112	4555170	288984	-26.9	21	34	0.07	Spud	L/B Robert	1	Mostly Healed
F113	4555110	288930	-26.6	40	99	0.11	Scour	Unknown	1	Little Change
F114	4555090	288927	-26.5	23	35	0.13	Spud	L/B Michael Eymard	1	Mostly Healed
F115	4555080	288943	-26.5	22	32	0.12	Spud	L/B Michael Eymard	1	Mostly Healed
F116	4555060	288925	-26.4	15	15	0.12	Spud	L/B Michael Eymard	1	Mostly Healed
F117	4554090	287674	-25.9	30	45	0.08	Scour	Unknown	1	Mostly Healed
F118	4554090	287670	-25.9	20	20	0.06	Scour	Unknown	1	Mostly Healed
F119	4554080	287682	-25.9	24	32	0.06	Scour	Unknown	1	Mostly Healed
F120	4554070	287663	-26.0	33	75	0.04	Scour	Unknown	1	Little Change

Notes: See Charts 3, 4, 5, and 6 for the location of each seafloor disturbance feature.

¹ UTM Zone 19, NAD83, Meter

² Elevation represents centroid location of the feature.

³ Change was infilling of feature.

⁴ Change was deepening of feature.

Feature ID	Northing ¹ (m)	Easting ¹ (m)	Elevation ² (m)	Feature Perimeter (m)	Feature Area (m ²)	Max Depth (m)	Feature Interpretation	Attributed Vessel	Construction Season	Relative Change
F121	4554060	287630	-26.0	12	11	0.12	Scour	Unknown	1	Mostly Healed
F122	4555750	289524	-23.7	31	66	0.1	Scour	Unknown	1	Some Change ³
F123	4555770	289508	-28.0	32	78	0.06	Scour	Unknown	1	Some Change ³
F124	4555750	289491	-25.4	36	99	0.07	Scour	Unknown	1	Some Change ³
F125	4555730	289508	-28.0	33	65	0.08	Scour	Unknown	1	Some Change ³
F126	4555110	288964	-26.6	30	62	0.02	Scour	Unknown	1	Little Change
F127	4555100	288947	-18.7	25	47	0.03	Scour	Unknown	1	Little Change
F128	4554570	288324	-13.8	37	98	0.06	Scour	Unknown	1	Some Change ³
F129	4554560	288339	-26.0	25	42	0.03	Scour	Unknown	1	Little Change
F130	4554070	287634	-17.7	43	90	0.12	Scour	Unknown	1	Some Change ³
F131	4554050	287648	-26.0	32	52	0.05	Scour	Unknown	1	Some Change ³
F132	4553650	286914	-18.9	21	32	0.05	Scour	Unknown	1	Some Change ³
F133	4553670	286929	-23.6	16	18	0.09	Scour	Unknown	1	Some Change ³

Notes: See Charts 3, 4, 5, and 6 for the location of each seafloor disturbance feature.

¹ UTM Zone 19, NAD83, Meter

² Elevation represents centroid location of the feature.

³ Change was infilling of feature.

⁴ Change was deepening of feature.

Feature ID	Northing ¹ (m)	Easting ¹ (m)	Elevation ² (m)	Feature Perimeter (m)	Feature Area (m ²)	Max Depth (m)	Feature Interpretation	Attributed Vessel	Construction Season	Relative Change
F134	4553670	286899	-23.3	19	22	0.1	Scour	Unknown	1	Some Change ³
F135	4553680	286913	-19.2	24	38	0.02	Scour	Unknown	1	Some Change ³
F136	4553280	287071	-21.7	93	155	0.05	Drag Mark	Unknown	1	Little Change
F137	4553290	287037	-21.1	58	65	0.1	Drag Mark	Unknown	1	Some Change ³
F138	4555090	288255	-25.3	48	40	0.09	Drag Mark	Unknown	1	Mostly Healed
F139	4555090	288225	-25.1	91	60	0.06	Drag Mark	Unknown	1	Mostly Healed
F140	4555030	288476	-25.1	86	34	0.06	Drag Mark	Unknown	1	Mostly Healed
F141	4554580	288290	-26.1	68	30	0.03	Drag Mark	Unknown	1	Mostly Healed
F142	4554580	288317	-26.2	53	19	0.06	Drag Mark	Unknown	1	Mostly Healed
F143	4554380	287514	-26.3	76	69	0.11	Drag Mark	Unknown	1	Some Change ³
F144	4554070	287607	-26.0	164	176	0.02	Drag Mark	Unknown	1	Mostly Healed
F145	4554090	287595	-26.1	146	131	0.02	Drag Mark	Unknown	1	Mostly Healed
F146	4554120	287565	-26.1	112	109	0.02	Drag Mark	Unknown	1	Mostly Healed

Notes: See Charts 3, 4, 5, and 6 for the location of each seafloor disturbance feature.

¹ UTM Zone 19, NAD83, Meter

² Elevation represents centroid location of the feature.

³ Change was infilling of feature.

⁴ Change was deepening of feature.

Feature ID	Northing ¹ (m)	Easting ¹ (m)	Elevation ² (m)	Feature Perimeter (m)	Feature Area (m ²)	Max Depth (m)	Feature Interpretation	Attributed Vessel	Construction Season	Relative Change
F147	4554050	287615	-26.0	272	292	0.03	Drag Mark	Unknown	1	Mostly Healed
F148	4553990	287487	-26.3	142	121	0.02	Drag Mark	Unknown	1	Mostly Healed
F149	4553990	287423	-26.1	291	225	0.05	Drag Mark	Unknown	1	Mostly Healed
F150	4553930	286775	-22.1	141	151	0.08	Drag Mark	Unknown	1	Some Change ³
F151	4553990	286768	-22.9	29	39	0.21	Drag Mark	Unknown	1	Some Change ³
F152	4554020	286959	-24.2	13	12	0.15	Circular Depression	Unknown	1	Mostly Healed
F153	4553510	287184	-23.3	10	7	0.12	Circular Depression	Unknown	1	Mostly Healed
F154	4554140	287279	-25.8	28	41	0.07	Drag Mark	Unknown	1	Some Change ³
F155	4554640	287558	-27.0	16	18	0.12	Circular Depression	Unknown	1	Mostly Healed
F156	4554330	287759	-26.1	12	9	0.20	Circular Depression	Unknown	1	Mostly Healed
F157	4554320	287709	-26.0	16	18	0.10	Circular Depression	Unknown	1	Mostly Healed
F158	4556180	289764	-28.0	161	129	0.02	Drag Mark	Unknown	1	Mostly Healed
F159	4556180	289793	-28.0	90	63	0.03	Drag Mark	Unknown	1	Mostly Healed

Notes: See Charts 3, 4, 5, and 6 for the location of each seafloor disturbance feature.

¹ UTM Zone 19, NAD83, Meter

² Elevation represents centroid location of the feature.

³ Change was infilling of feature.

⁴ Change was deepening of feature.

Feature ID	Northing ¹ (m)	Easting ¹ (m)	Elevation ² (m)	Feature Perimeter (m)	Feature Area (m ²)	Max Depth (m)	Feature Interpretation	Attributed Vessel	Construction Season	Relative Change
F160	4555720	289530	-28.4	54	196	0.60	Spud	L/B <i>Brave Tern</i>	2	Little Change
F161	4555700	289552	-28.6	58	246	1.2	Spud	L/B <i>Brave Tern</i>	2	Little Change
F162	4555750	289601	-28.3	58	245	0.90	Spud	L/B <i>Brave Tern</i>	2	Little Change
F163	4555770	289579	-28.5	52	187	0.87	Spud	L/B <i>Brave Tern</i>	2	Little Change
F164	4555070	288987	-27.5	56	214	0.90	Spud	L/B <i>Brave Tern</i>	2	Some Change ³
F165	4555110	289037	-27.3	46	148	0.60	Spud	L/B <i>Brave Tern</i>	2	Mostly Healed
F166	4555130	289017	-27.4	50	170	0.85	Spud	L/B <i>Brave Tern</i>	2	Some Change ³
F167	4555090	288966	-27.3	51	185	0.86	Spud	L/B <i>Brave Tern</i>	2	Some Change ³
F168	4554510	288367	-26.4	57	222	0.85	Spud	L/B <i>Brave Tern</i>	2	Mostly Healed
F169	4554560	288417	-27.0	67	313	1.27	Spud	L/B <i>Brave Tern</i>	2	Mostly Healed
F170	4554580	288397	-26.8	54	213	0.75	Spud	L/B <i>Brave Tern</i>	2	Mostly Healed
F171	4554530	288345	-26.8	59	255	1.16	Spud	L/B <i>Brave Tern</i>	2	Mostly Healed
F172	4554070	287741	-25.8	50	191	0.62	Spud	L/B <i>Brave Tern</i>	2	Little Change

Notes: See Charts 3, 4, 5, and 6 for the location of each seafloor disturbance feature.

¹ UTM Zone 19, NAD83, Meter

² Elevation represents centroid location of the feature.

³ Change was infilling of feature.

⁴ Change was deepening of feature.

Feature ID	Northing ¹ (m)	Easting ¹ (m)	Elevation ² (m)	Feature Perimeter (m)	Feature Area (m ²)	Max Depth (m)	Feature Interpretation	Attributed Vessel	Construction Season	Relative Change
F173	4554090	287720	-25.7	49	174	0.75	Spud	L/B <i>Brave Tern</i>	2	Little Change
F174	4554050	287669	-26.5	48	160	0.75	Spud	L/B <i>Brave Tern</i>	2	Mostly Healed
F175	4554030	287690	-26.4	48	164	0.75	Spud	L/B <i>Brave Tern</i>	2	Mostly Healed
F176	4553670	287009	-24.2	41	124	0.14	Spud	L/B <i>Brave Tern</i>	2	Mostly Healed
F177	4553690	286988	-24.3	45	150	0.30	Spud	L/B <i>Brave Tern</i>	2	Mostly Healed
F178	4553620	286958	-23.2	41	124	0.06	Spud	L/B <i>Brave Tern</i>	2	Mostly Healed
F179	4553640	286937	-23.4	38	110	0.09	Spud	L/B <i>Brave Tern</i>	2	Mostly Healed
F180	4553870	287675	-25.5	47	68	0.10	Drag Mark	Unknown	2	Mostly Healed
F181	4554820	289162	-26.7	16	19	0.12	Circular Depression	Unknown	2	Mostly Healed
F182	4554830	289135	-26.6	15	15	0.10	Circular Depression	Unknown	2	Mostly Healed
F183	4554840	289150	-26.4	12	10	0.07	Circular Depression	Unknown	2	Mostly Healed
F184	4554790	289089	-27.2	59	84	0.08	Drag Mark	Unknown	2	Mostly Healed
F185	4555100	288885	-26.6	21	30	0.08	Circular Depression	Unknown	2	Mostly Healed

Notes: See Charts 3, 4, 5, and 6 for the location of each seafloor disturbance feature.

¹ UTM Zone 19, NAD83, Meter

² Elevation represents centroid location of the feature.

³ Change was infilling of feature.

⁴ Change was deepening of feature.

Feature ID	Northing ¹ (m)	Easting ¹ (m)	Elevation ² (m)	Feature Perimeter (m)	Feature Area (m ²)	Max Depth (m)	Feature Interpretation	Attributed Vessel	Construction Season	Relative Change
F186	4555120	288881	-26.7	17	19	0.09	Circular Depression	Unknown	2	Mostly Healed
F187	4555210	288894	-27.4	16	19	0.09	Circular Depression	Unknown	2	Mostly Healed
F188	4555200	288876	-27.3	13	13	0.03	Circular Depression	Unknown	2	Mostly Healed
F189	4555190	288919	-27.1	14	14	0.05	Circular Depression	Unknown	2	Mostly Healed
F190	4555180	288904	-27.1	15	15	0.07	Circular Depression	Unknown	2	Mostly Healed
F191	4555220	289063	-27.0	12	9	0.09	Circular Depression	Unknown	2	Mostly Healed
F192	4555420	289116	-27.3	76	61	0.06	Drag Mark	Unknown	2	Mostly Healed
F193	4555440	289142	-27.4	145	107	0.06	Drag Mark	Unknown	2	Mostly Healed
F194	4555450	289665	-27.1	35	69	0.08	Circular Depression	Unknown	2	Mostly Healed
F195	4555450	289725	-27.2	21	28	0.06	Circular Depression	Unknown	2	Mostly Healed
F196	4555480	289713	-27.1	21	30	0.06	Circular Depression	Unknown	2	Mostly Healed
F197	4555460	289698	-27.1	21	33	0.06	Circular Depression	Unknown	2	Mostly Healed
F198	4555630	289501	-27.5	15	16	0.11	Circular Depression	Unknown	2	Mostly Healed

Notes: See Charts 3, 4, 5, and 6 for the location of each seafloor disturbance feature.

¹ UTM Zone 19, NAD83, Meter

² Elevation represents centroid location of the feature.

³ Change was infilling of feature.

⁴ Change was deepening of feature.

Feature ID	Northing ¹ (m)	Easting ¹ (m)	Elevation ² (m)	Feature Perimeter (m)	Feature Area (m ²)	Max Depth (m)	Feature Interpretation	Attributed Vessel	Construction Season	Relative Change
F199	4555640	289514	-27.4	16	18	0.13	Circular Depression	Unknown	2	Mostly Healed
F200	4555650	289499	-27.5	11	8	0.06	Circular Depression	Unknown	2	Mostly Healed
F201	4555650	289482	-27.8	27	49	0.16	Circular Depression	Unknown	2	Some Change ³
F202	4555660	289489	-27.6	13	10	0.06	Circular Depression	Unknown	2	Mostly Healed
F203	4555640	289477	-27.6	27	25	0.07	Drag Mark	Unknown	2	Mostly Healed
F204	4555650	289522	-27.4	9	6	0.05	Circular Depression	Unknown	2	Mostly Healed
F205	4555660	289519	-27.4	10	7	0.07	Circular Depression	Unknown	2	Mostly Healed
F206	4555670	289505	-27.6	11	8	0.07	Circular Depression	Unknown	2	Mostly Healed
F207	4555670	289500	-27.6	11	8	0.06	Circular Depression	Unknown	2	Mostly Healed
F208	4555670	289487	-27.8	16	18	0.11	Circular Depression	Unknown	2	Mostly Healed
F209	4555120	288971	-26.7	15	15	0.04	Spud	L/B <i>Michael Eymard</i>	2	Mostly Healed
F210	4555130	288968	-26.7	15	15	0.09	Spud	L/B <i>Michael Eymard</i>	2	Mostly Healed

Notes: See Charts 3, 4, 5, and 6 for the location of each seafloor disturbance feature.

¹ UTM Zone 19, NAD83, Meter

² Elevation represents centroid location of the feature.

³ Change was infilling of feature.

⁴ Change was deepening of feature.

Feature ID	Northing ¹ (m)	Easting ¹ (m)	Elevation ² (m)	Feature Perimeter (m)	Feature Area (m ²)	Max Depth (m)	Feature Interpretation	Attributed Vessel	Construction Season	Relative Change
F211	4555130	288958	-26.8	18	22	0.10	Spud	L/B <i>Michael Eymard</i>	2	Mostly Healed
F212	4555140	288954	-26.9	25	44	0.17	Spud	L/B <i>Michael Eymard</i>	2	Mostly Healed
F213	4555150	288987	-26.8	21	33	0.07	Spud	L/B <i>Michael Eymard</i>	2	Some Change ³
F214	4555140	288952	-26.8	31	37	0.05	Circular Depression	Unknown	2	Mostly Healed
F215	4554870	288574	-25.6	27	28	0.08	Drag Mark	Unknown	2	Mostly Healed
F216	4554830	288547	-25.9	24	19	0.06	Drag Mark	Unknown	2	Mostly Healed
F217	4555680	289482	-27.8	33	62	0.13	Circular Depression	Unknown	2	Little Change
F218	4555690	289501	-27.7	22	37	0.13	Circular Depression	Unknown	2	Mostly Healed
F219	4555690	289497	-27.8	31	43	0.10	Circular Depression	Unknown	2	Mostly Healed
F220	4555660	289515	-27.5	20	28	0.14	Circular Depression	Unknown	2	Mostly Healed
F221	4555660	289509	-27.6	24	41	0.15	Circular Depression	Unknown	2	Little Change

Notes: See Charts 3, 4, 5, and 6 for the location of each seafloor disturbance feature.

¹ UTM Zone 19, NAD83, Meter

² Elevation represents centroid location of the feature.

³ Change was infilling of feature.

⁴ Change was deepening of feature.

Feature ID	Northing ¹ (m)	Easting ¹ (m)	Elevation ² (m)	Feature Perimeter (m)	Feature Area (m ²)	Max Depth (m)	Feature Interpretation	Attributed Vessel	Construction Season	Relative Change
F222	4555850	289591	-27.8	17	14	0.11	Circular Depression	Unknown	2	Mostly Healed
F223	4555860	289598	-27.8	11	9	0.09	Circular Depression	Unknown	2	Mostly Healed
F224	4555870	289592	-27.9	12	10	0.06	Circular Depression	Unknown	2	Mostly Healed
F225	4555870	289585	-27.9	7	3	0.03	Circular Depression	Unknown	2	Mostly Healed
F226	4555870	289464	-28.6	20	27	0.10	Circular Depression	Unknown	2	Mostly Healed
F227	4555850	289491	-28.5	21	26	0.16	Circular Depression	Unknown	2	Mostly Healed
F228	4555820	289428	-28.7	20	23	0.15	Circular Depression	Unknown	2	Mostly Healed
F229	4555730	289398	-28.4	28	30	0.05	Drag Mark	Unknown	2	Mostly Healed
F230	4555760	289426	-28.4	17	20	0.08	Circular Depression	Unknown	2	Mostly Healed
F231	4555780	289517	-28.0	17	18	0.12	Spud	L/B <i>Michael Eymard</i>	2	Mostly Healed
F232	4555770	289518	-28.0	17	22	0.07	Spud	L/B <i>Michael Eymard</i>	2	Mostly Healed

Notes: See Charts 3, 4, 5, and 6 for the location of each seafloor disturbance feature.

¹ UTM Zone 19, NAD83, Meter

² Elevation represents centroid location of the feature.

³ Change was infilling of feature.

⁴ Change was deepening of feature.

Feature ID	Northing ¹ (m)	Easting ¹ (m)	Elevation ² (m)	Feature Perimeter (m)	Feature Area (m ²)	Max Depth (m)	Feature Interpretation	Attributed Vessel	Construction Season	Relative Change
F233	4555780	289523	-28.0	14	13	0.05	Spud	L/B <i>Michael Eymard</i>	2	Mostly Healed
F234	4555770	289523	-27.9	16	17	0.04	Spud	L/B <i>Michael Eymard</i>	2	Mostly Healed
F235	4555760	289532	-27.8	16	17	0.09	Spud	L/B <i>Michael Eymard</i>	2	Mostly Healed
F236	4555760	289538	-27.9	25	44	0.11	Spud	L/B <i>Michael Eymard</i>	2	Mostly Healed
F237	4555770	289532	-27.9	19	24	0.11	Spud	L/B <i>Michael Eymard</i>	2	Mostly Healed
F238	4555770	289528	-27.8	15	16	0.04	Spud	L/B <i>Michael Eymard</i>	2	Mostly Healed
F239	4555790	289544	-27.9	12	10	0.05	Spud	L/B <i>Michael Eymard</i>	2	Mostly Healed
F240	4555790	289551	-27.9	19	23	0.12	Spud	L/B <i>Michael Eymard</i>	2	Mostly Healed

Notes: See Charts 3, 4, 5, and 6 for the location of each seafloor disturbance feature.

¹ UTM Zone 19, NAD83, Meter

² Elevation represents centroid location of the feature.

³ Change was infilling of feature.

⁴ Change was deepening of feature.

Feature ID	Northing ¹ (m)	Easting ¹ (m)	Elevation ² (m)	Feature Perimeter (m)	Feature Area (m ²)	Max Depth (m)	Feature Interpretation	Attributed Vessel	Construction Season	Relative Change
F241	4555790	289545	-27.9	16	17	0.06	Spud	L/B <i>Michael Eymard</i>	2	Mostly Healed
F242	4555790	289550	-27.9	14	14	0.05	Spud	L/B <i>Michael Eymard</i>	2	Mostly Healed
F243	4555780	289543	-27.9	37	48	0.08	Drag Mark	Unknown	2	Mostly Healed
F244	4555440	288879	-28.2	24	41	0.08	Circular Depression	Unknown	2	Mostly Healed
F245	4555310	288352	-27.6	178	169	0.08	Drag Mark	Unknown	2	Mostly Healed
F246	4554090	287652	-26.4	44	145	0.41	Circular Depression	Unknown	2	Mostly Healed
F247	4554090	287663	-26.3	37	100	0.41	Circular Depression	Unknown	2	Mostly Healed
F248	4554080	287671	-26.1	35	82	0.11	Circular Depression	Unknown	2	Mostly Healed
F249	4554080	287678	-25.9	30	63	0.10	Circular Depression	Unknown	2	Mostly Healed
F250	4553980	287650	-25.9	32	72	0.17	Circular Depression	Unknown	2	Mostly Healed
F251	4553990	287625	-25.8	27	51	0.25	Circular Depression	Unknown	2	Mostly Healed
F252	4554440	286955	-27.4	112	80	0.13	Drag Mark	Unknown	2	Mostly Healed

Notes: See Charts 3, 4, 5, and 6 for the location of each seafloor disturbance feature.

¹ UTM Zone 19, NAD83, Meter

² Elevation represents centroid location of the feature.

³ Change was infilling of feature.

⁴ Change was deepening of feature.

Feature ID	Northing ¹ (m)	Easting ¹ (m)	Elevation ² (m)	Feature Perimeter (m)	Feature Area (m ²)	Max Depth (m)	Feature Interpretation	Attributed Vessel	Construction Season	Relative Change
F253	4554650	287927	-26.3	25	39	0.07	Circular Depression	Unknown	2	Mostly Healed
F254	4555760	289455	-28.3	28	50	0.13	Circular Depression	Unknown	2	Mostly Healed
F255	4555800	289452	-28.4	25	32	0.13	Circular Depression	Unknown	2	Mostly Healed
F256	4555840	289479	-28.4	26	36	0.08	Circular Depression	Unknown	2	Mostly Healed
F257	4555290	289165	-26.8	34	36	0.04	Drag Mark	Unknown	2	Mostly Healed
F258	4554880	289095	-26.2	15	16	0.08	Circular Depression	Unknown	2	Little Change
F259	4554900	289079	-26.2	13	13	0.06	Circular Depression	Unknown	2	Mostly Healed
F260	455800	289404	-28.6	333	376	0.27	Drag Mark	Unknown	2	Mostly Healed
F261	4555730	289515	-27.9	19	20	0.09	Scour	Unknown	2	Mostly Healed
F262	4555740	289531	-27.8	24	31	0.12	Scour	Unknown	2	Mostly Healed
F263	4555840	289507	-28.3	60	55	0.13	Scour	N/A	Post-Construction	Little Change
F264	4555820	289487	-28.3	222	219	0.20	Scour	N/A	Post-Construction	Little Change
F265	4555740	289475	-28.1	122	112	0.19	Scour	N/A	Post-Construction	Some Change ³

Notes: See Charts 3, 4, 5, and 6 for the location of each seafloor disturbance feature.

¹ UTM Zone 19, NAD83, Meter

² Elevation represents centroid location of the feature.

³ Change was infilling of feature.

⁴ Change was deepening of feature.

Feature ID	Northing ¹ (m)	Easting ¹ (m)	Elevation ² (m)	Feature Perimeter (m)	Feature Area (m ²)	Max Depth (m)	Feature Interpretation	Attributed Vessel	Construction Season	Relative Change
F266	4555790	289475	-28.1	33	21	0.09	Scour	N/A	Post-Construction	Little Change
F267	4555760	289483	-28.2	30	25	0.10	Scour	N/A	Post-Construction	Some Change ³
F268	4555740	289482	-28.2	47	30	0.10	Scour	N/A	Post-Construction	Little Change
F269	4555710	289445	-28.2	13	11	0.08	Scour	N/A	Post-Construction	Some Change ³
F270	4555150	288908	-26.9	199	154	0.20	Scour	N/A	Post-Construction	Little Change
F271	4555160	288915	-27.0	84	53	0.07	Scour	N/A	Post-Construction	Little Change
F272	4555120	288920	-26.7	33	29	0.14	Scour	N/A	Post-Construction	Little Change
F273	4555100	288911	-26.6	81	86	0.17	Scour	N/A	Post-Construction	Little Change
F274	4555100	288918	-26.6	60	50	0.15	Scour	N/A	Post-Construction	Little Change
F275	4554192	288755	-24.6	64	70	0.20	Drag Mark	N/A	Post-Construction	Mostly Healed

Notes: See Charts 3, 4, 5, and 6 for the location of each seafloor disturbance feature.

¹ UTM Zone 19, NAD83, Meter

² Elevation represents centroid location of the feature.



³ Change was infilling of feature.

⁴ Change was deepening of feature.

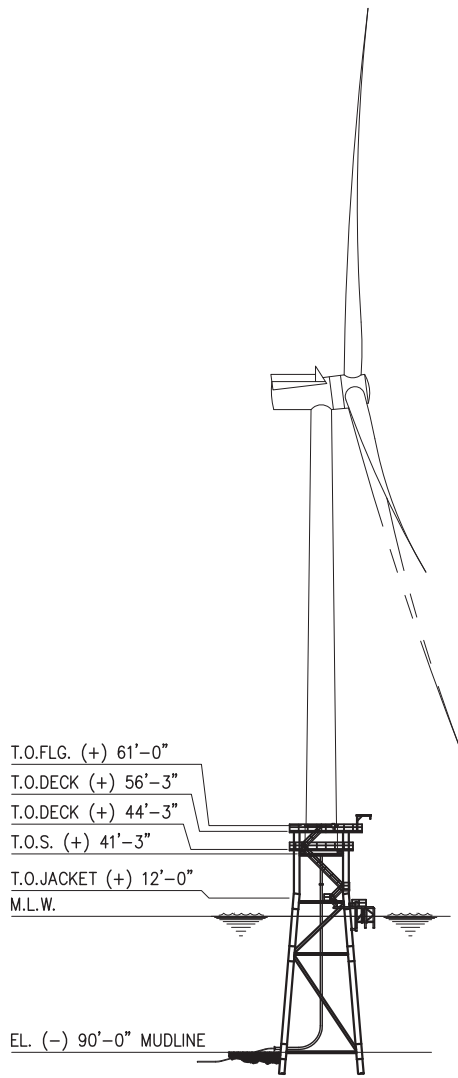
D. TYPICAL CONSTRUCTION DRAWINGS



ELEVATION

 <p>Upstream Engineering LLC "Providing Value Added Engineering Services" HOUSTON, TEXAS www.upstreamengineering.com (281) 531-0047</p>				 <p>DEEPWATERWIND®</p>			
<p>Registration No.: F-2752</p>				<p>ASSEMBLY ELEVATION TURBINE & PLATFORM</p>			
B	03/15/12	REVISED ISSUED FOR PERMITTING	JR	RS			
A	01/24/12	ISSUED FOR PERMITTING	JR	RS			
No.	DATE	REVISION	BY	APP.			
DESIGNED BY: D. YBARRA		SCALE: 1/128"=1'-0"		PROJ. No.: P12-002			
DRAWN BY: J. RHAME		DATE: 01/11/12		FILENAME: 9001.dwg		REV. No.: B	

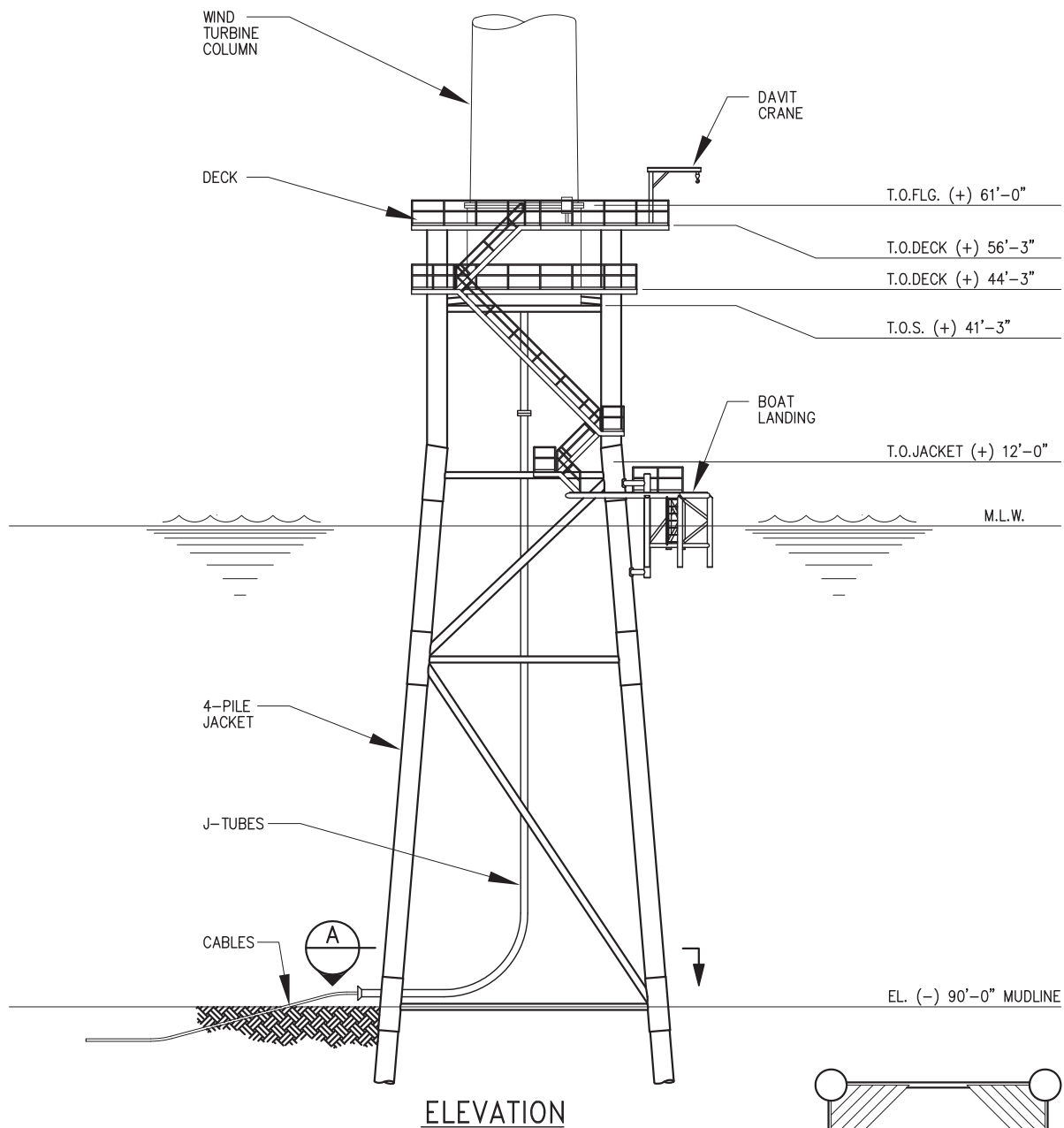

ELEVATION

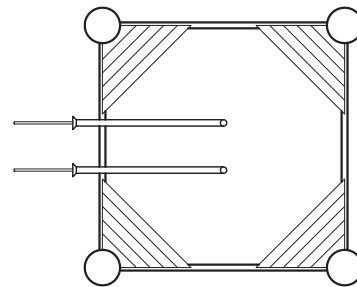

SECTION A
SCALE 1"=40'-0"

Upstream Engineering LLC
 "Providing Value Added Engineering Services"
 HOUSTON, TEXAS www.upstreamengineering.com (281) 531-0047
Registration No.: F-2752

No.	DATE	REVISION	BY	APP.
C		REVISED ISSUED FOR PERMITTING	JR	
B	03/15/12	REVISED ISSUED FOR PERMITTING	JR	RS

DESIGNED BY: D. YBARRA
 SCALE: 1/32"=1'-0"
 DRAWN BY: J. RHAME
 DATE: 01/11/12

DEEPWATERWIND®

4-PILE JACKET w/DECK STRUCTURE

Figure 2

PROJ. No.: P12-002
 FILENAME: 9002.dwg

REV. No.: C

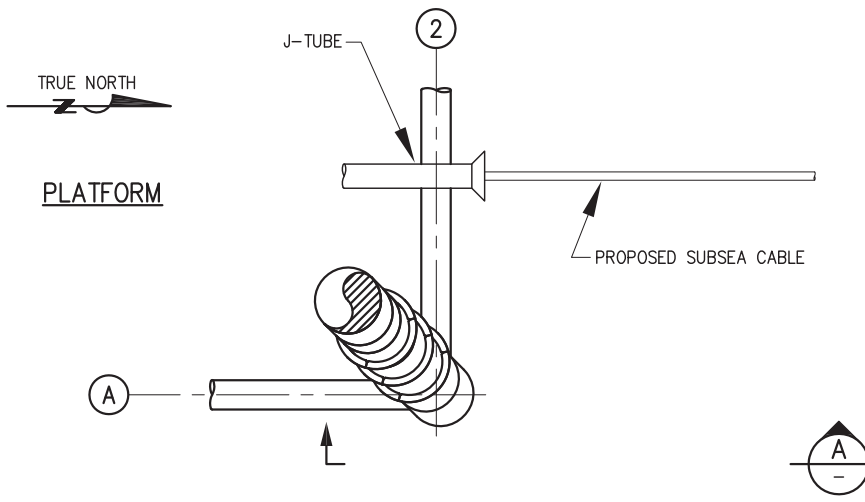

DETAIL 1
 SCALE — 3/16"=1'-0"

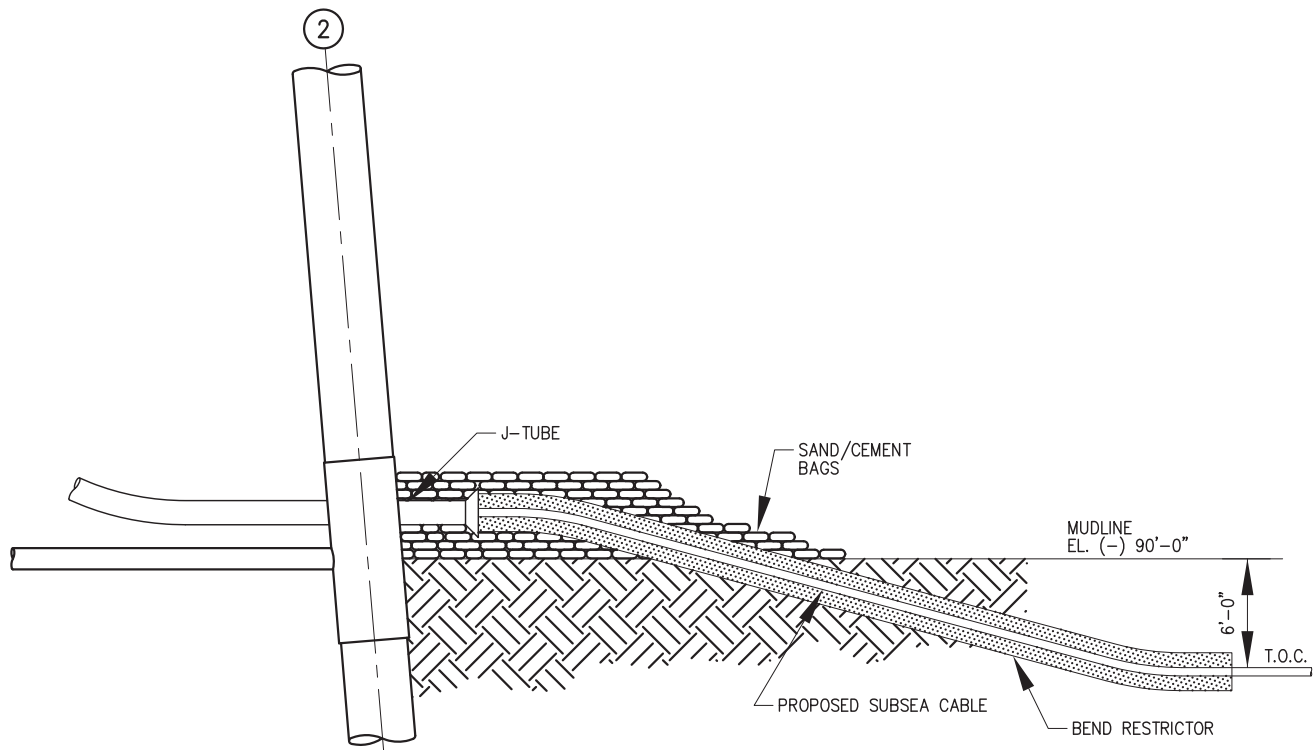

ELEVATION A
 SCALE — 3/16"=1'-0"

Upstream Engineering LLC
 "Providing Value Added Engineering Services"
 HOUSTON, TEXAS www.upstreamengineering.com (281) 531-0047

Registration No.: F-2752

No.	DATE	REVISION	BY	APP.
B	03/15/12	REVISED ISSUED FOR PERMITTING	JR	RS
A	01/24/12	ISSUED FOR PERMITTING	JR	RS

DESIGNED BY: D. YBARRA SCALE: AS NOTED
 DRAWN BY: J. RHAME DATE: 01/11/12



CABLE AT J-TUBE

PROJ. No.: P12-002 FILENAME: 9009.dwg	<h2>Figure 3</h2>	REV. No.: B
--	-------------------	--------------------

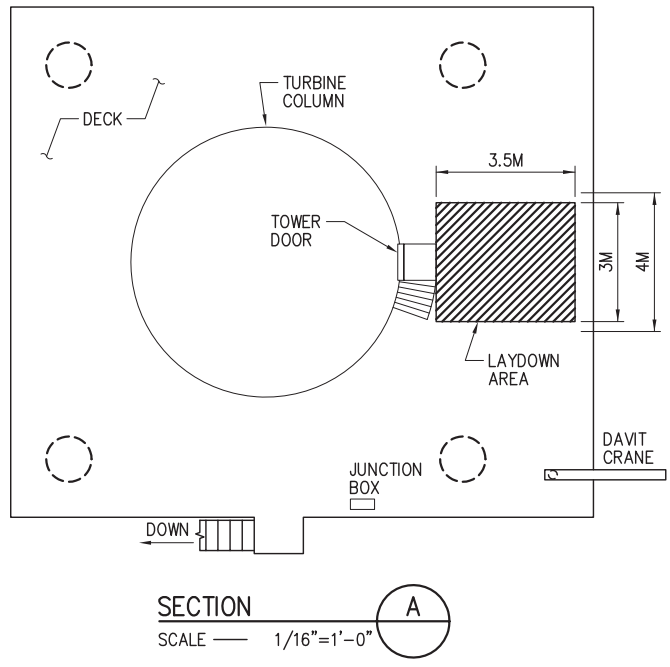
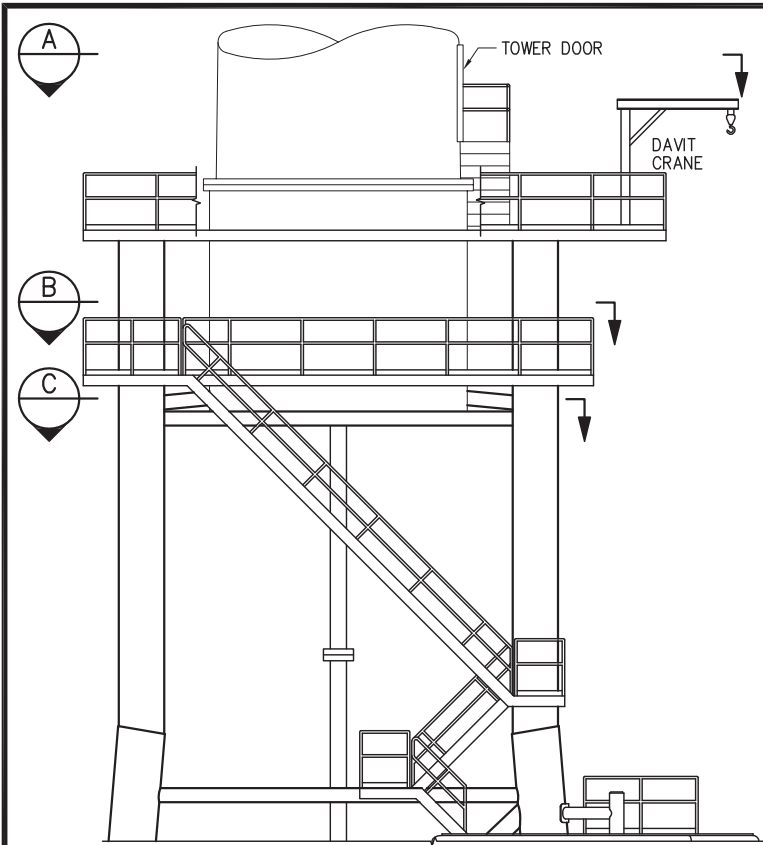

DETAIL 1
SCALE 1/16"=1'-0"

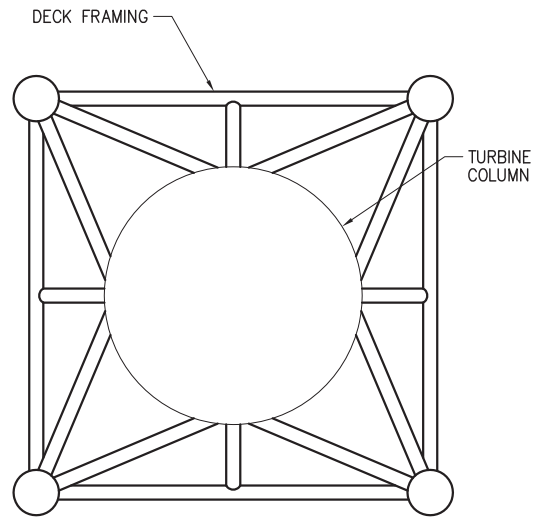
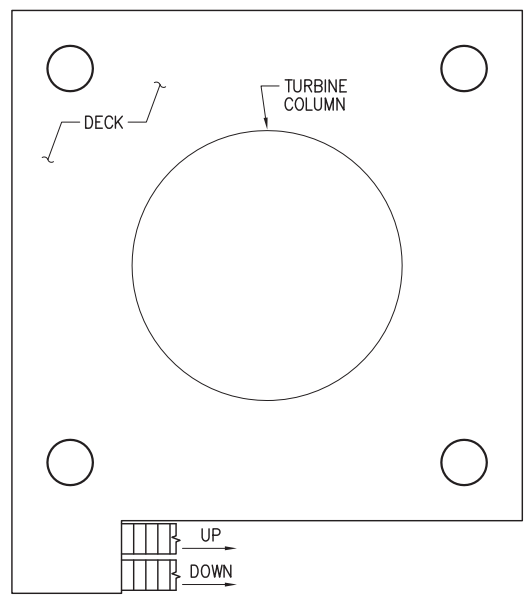

Upstream Engineering LLC
 "Providing Value Added Engineering Services"
 HOUSTON, TEXAS www.upstreamengineering.com (281) 531-0047



DETAILS AND SECTIONS

No.	DATE	REVISION	BY	APP.
B		REVISED ISSUED FOR PERMITTING	JR	
A	03/15/12	ISSUED FOR PERMITTING	JR	RS

DESIGNED BY: D. YBARRA	SCALE: 1/16"=1'-0"
DRAWN BY: J. RHAME	DATE: 03/08/12

PROJ. No.: P12-002
 FILENAME: 9010.dwg

Figure 4

REV. No.:
B

THIS DRAWING WAS PREPARED BY MOTT MACDONALD FOR A SPECIFIC PROJECT, TAKING INTO CONSIDERATION THE SPECIFIC AND UNIQUE REQUIREMENTS OF THE PROJECT. REUSE OF THIS DRAWING OR ANY INFORMATION CONTAINED IN THIS DRAWING FOR ANY PURPOSE IS PROHIBITED UNLESS WRITTEN PERMISSION FROM BOTH POWER AND POWER'S CLIENT IS GRANTED.

A	ISSUED FOR REVIEW	2/09/12	MT	CMD	CMD	
REV	REVISIONS	DATE	DRN	DSGN	CKD	APPD

LEGEND

- ① - CONDUCTOR
- ② - FILLING COMPOUND
- ③ - CONDUCTOR SCREEN
- ④ - INSULATION
- ⑤ - INSULATION SCREEN
- ⑥ - **LEAD ALLOY SHEATH**
- ⑦ - INTERSTITIAL FIBER OPTIC
- ⑧ - YARN FILLERS
- ⑨ - BINDER TAPES
- ⑩ - ARMOUR WIRES
- ⑪ - YARN AND BITUMEN

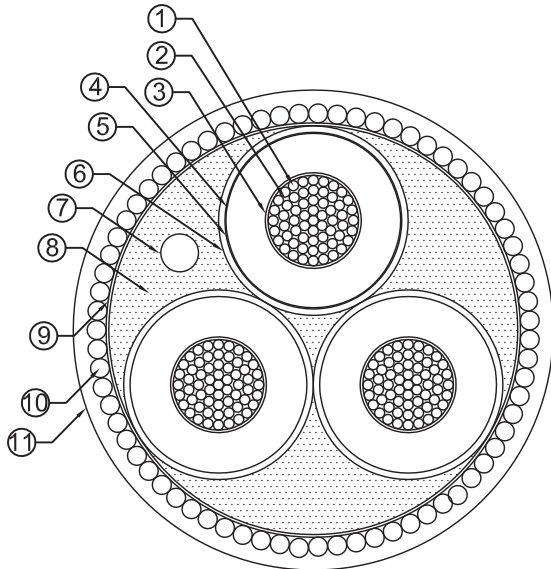

35KV 3-CORE
SUBMARINE CABLE

SUBMARINE_CABLE_DETAIL.dwg



	DSGN	CMD	02/09/2012
	DRN	MT	02/09/2012
	CKD	CMD	02/09/2012
	SCALE: N.T.S		
REFERENCE DRAWINGS	FOR 8.5x11 DWG ONLY		



DEEPWATER WIND	JOB NUMBER	REV
BLOCK ISLAND TRANSMISSION PROJECT	276847	A
TYPICAL 3-CORE SUBMARINE CABLE	Figure 5	

THIS DRAWING WAS PREPARED BY POWER ENGINEERS, INC. FOR A SPECIFIC PROJECT, TAKING INTO CONSIDERATION THE SPECIFIC AND UNIQUE REQUIREMENTS OF THE PROJECT. REUSE OF THIS DRAWING OR ANY INFORMATION CONTAINED IN THIS DRAWING FOR ANY PURPOSE IS PROHIBITED UNLESS WRITTEN PERMISSION FROM BOTH POWER AND POWER'S CLIENT IS GRANTED.

D	ISSUED FOR REVIEW	02/14/2012	JJS	JJS	DEJ	
C	ISSUED FOR REVIEW	02/03/2012	JJS	JJS	DEJ	
B	ISSUED FOR REVIEW	01/30/2012	JJS	JJS	DEJ	
A	ISSUED FOR REVIEW	01/17/2012	JJS	JJS	DEJ	
REV	REVISIONS	DATE	DRN	DSGN	CKD	APPD

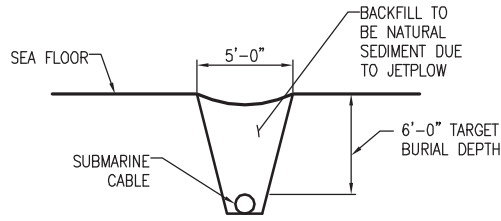

SECTION
SCALE N.T.S.

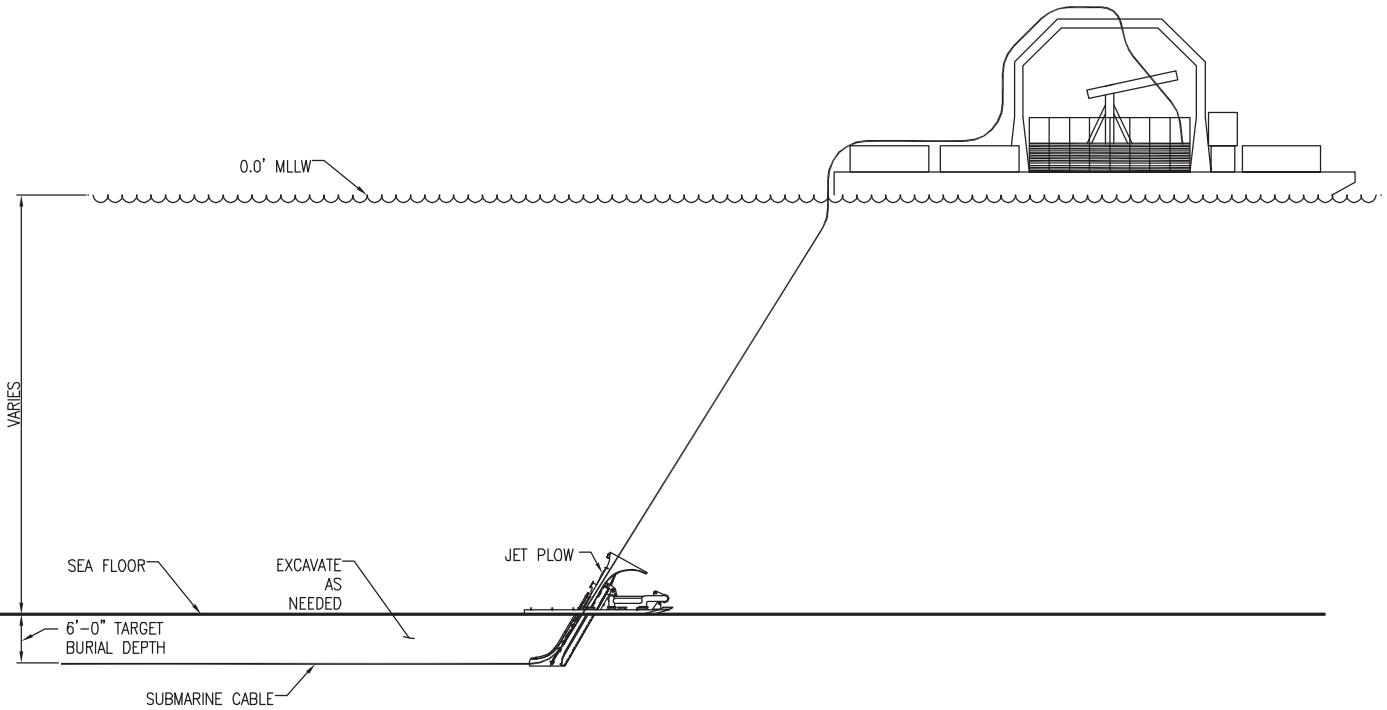

ELEVATION VIEW
SCALE N.T.S.



Submarine Detail.dwg

	DSGN	JJS	1/17/2012
	DRN	JJS	1/17/2012
	CKD	DEJ	1/17/2012
	SCALE:	N.T.S.	
REFERENCE DRAWINGS	FOR 8.5x11 DWG ONLY		



DEEPWATER WIND	JOB NUMBER	REV
BLOCK ISLAND TRANSMISSION PROJECT	119630	D
SUBMARINE DETAIL	Figure 6	

THIS DRAWING WAS PREPARED BY POWER ENGINEERS, INC. FOR A SPECIFIC PROJECT, TAKING INTO CONSIDERATION THE SPECIFIC AND UNIQUE REQUIREMENTS OF THE PROJECT. REUSE OF THIS DRAWING OR ANY INFORMATION CONTAINED IN THIS DRAWING FOR ANY PURPOSE IS PROHIBITED UNLESS WRITTEN PERMISSION FROM BOTH POWER AND POWER'S CLIENT IS GRANTED.

B	ISSUED FOR REVIEW	04/16/2012	JJS	JJS	DEJ	
A	ISSUED FOR REVIEW	04/13/2012	JJS	JJS	DEJ	
REV	REVISIONS	DATE	DRN	DSGN	CKD	APPD

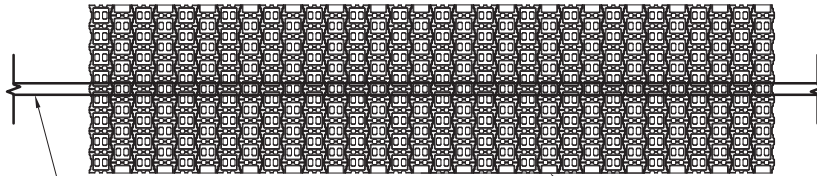

PROPOSED MARINE CABLE

CONCRETE MATS MAY BE INSTALLED OVER THE CABLE WHENEVER A MINIMUM OF 4'-0" OF COVER IS NOT ACHIEVED (SEE NOTE 1)

PLAN VIEW

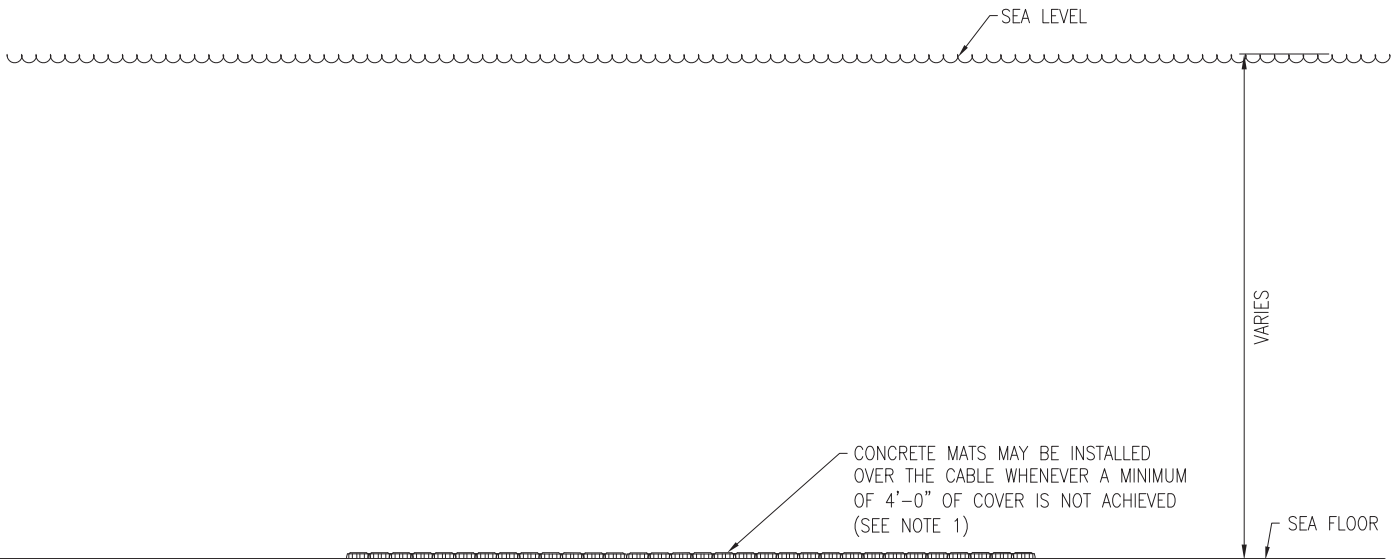

PROPOSED MARINE CABLE

PROFILE VIEW

SHALLOW PENETRATION DETAIL

SCALE N.T.S.

NOTES:

- ROCK DROPPING WITH SIMILAR PROFILE MAY BE USED IN LIEU OF CONCRETE MATS WHERE TARGER DEPTH WAS NOT ACHIEVED.

SHALLOW PENETRATION.dwg



	DSGN	JJS	04/13/2012
	DRN	JJS	04/13/2012
	CKD	DEJ	04/13/2012
	SCALE:	N.T.S.	
REFERENCE DRAWINGS	FOR 8.5x11 DWG ONLY		

DEEPWATER WIND	JOB NUMBER	REV
BLOCK ISLAND TRANSMISSION PROJECT	119630	B
SHALLOW PENETRATION DETAIL	Figure 7	

THIS DRAWING WAS PREPARED BY MOTT MACDONALD FOR A SPECIFIC PROJECT, TAKING INTO CONSIDERATION THE SPECIFIC AND UNIQUE REQUIREMENTS OF THE PROJECT. REUSE OF THIS DRAWING OR ANY INFORMATION CONTAINED IN THIS DRAWING FOR ANY PURPOSE IS PROHIBITED UNLESS WRITTEN PERMISSION FROM BOTH POWER AND POWER'S CLIENT IS GRANTED.

A	ISSUED FOR REVIEW	2/09/12	MT	CMD	CMD	
REV	REVISIONS	DATE	DRN	DSGN	CKD	APPD

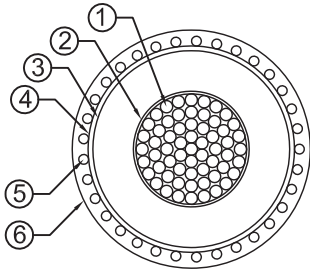

35KV URD
CABLE

LEGEND

- ① - CONDUCTOR
- ② - CONDUCTOR SCREEN
- ③ - INSULATION
- ④ - INSULATION SCREEN
- ⑤ - CONCENTRIC CONDUCTOR
- ⑥ - JACKET
- ⑦ - CONDUIT

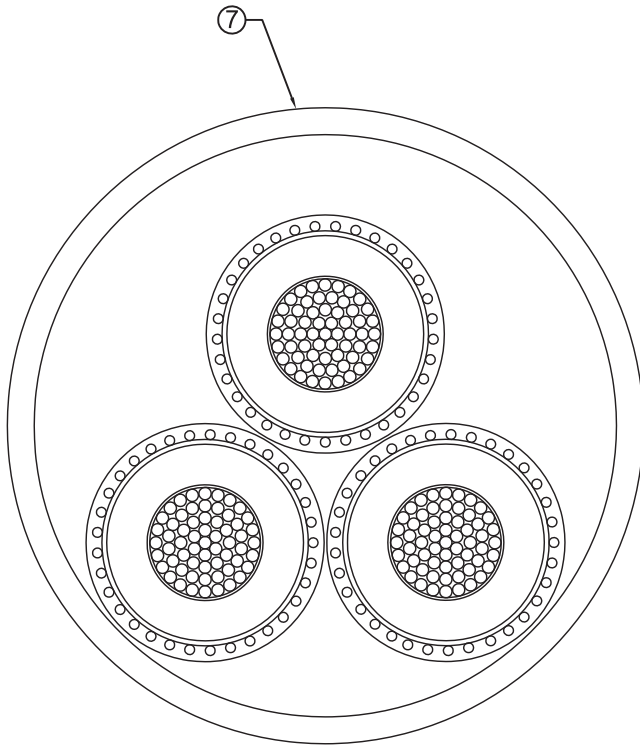

35KV CABLE
TREFOIL IN
CONDUIT

UPLAND CABLE DETAIL.dwg



	DSGN	CMD	02/09/2012
	DRN	MT	02/09/2012
	CKD	CMD	02/09/2012
	SCALE:	N.T.S	
REFERENCE DRAWINGS	FOR 8.5x11 DWG ONLY		



DEEPWATER WIND	JOB NUMBER	REV
BLOCK ISLAND TRANSMISSION PROJECT	276847	A
TYPICAL UPLAND CABLE	Figure 8	

THIS DRAWING WAS PREPARED BY POWER ENGINEERS, INC. FOR A SPECIFIC PROJECT, TAKING INTO CONSIDERATION THE SPECIFIC AND UNIQUE REQUIREMENTS OF THE PROJECT. REUSE OF THIS DRAWING OR ANY INFORMATION CONTAINED IN THIS DRAWING FOR ANY PURPOSE IS PROHIBITED UNLESS WRITTEN PERMISSION FROM BOTH POWER AND POWER'S CLIENT IS GRANTED.

C	ISSUED FOR REVIEW	02/14/2012	JJS	JJS	DEJ	
B	ISSUED FOR REVIEW	02/03/2012	JJS	JJS	DEJ	
A	ISSUED FOR REVIEW	12/01/2011	JJS	JJS	DEJ	
REV	REVISIONS	DATE	DRN	DSGN	CKD	APPD

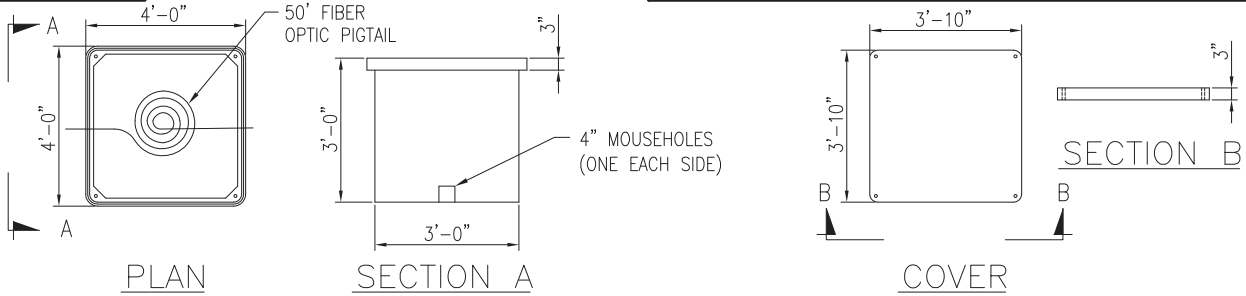

FIBER OPTIC HAND HOLE

NOTE
 QUAZITE 48"x48" PG COVER AND BOX
 MADE FROM POLYMER CONCRETE.

SCALE N.T.S.

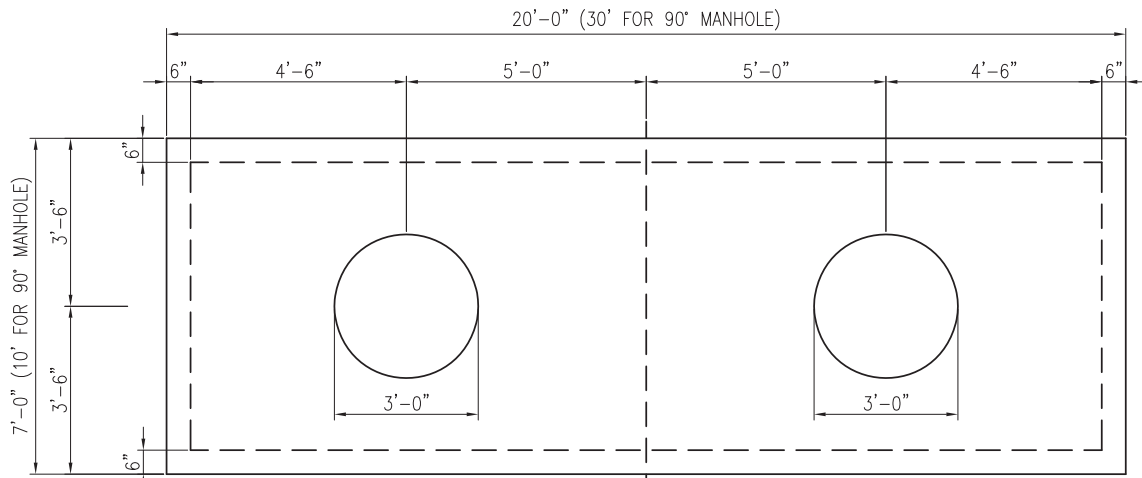

PLAN VIEW

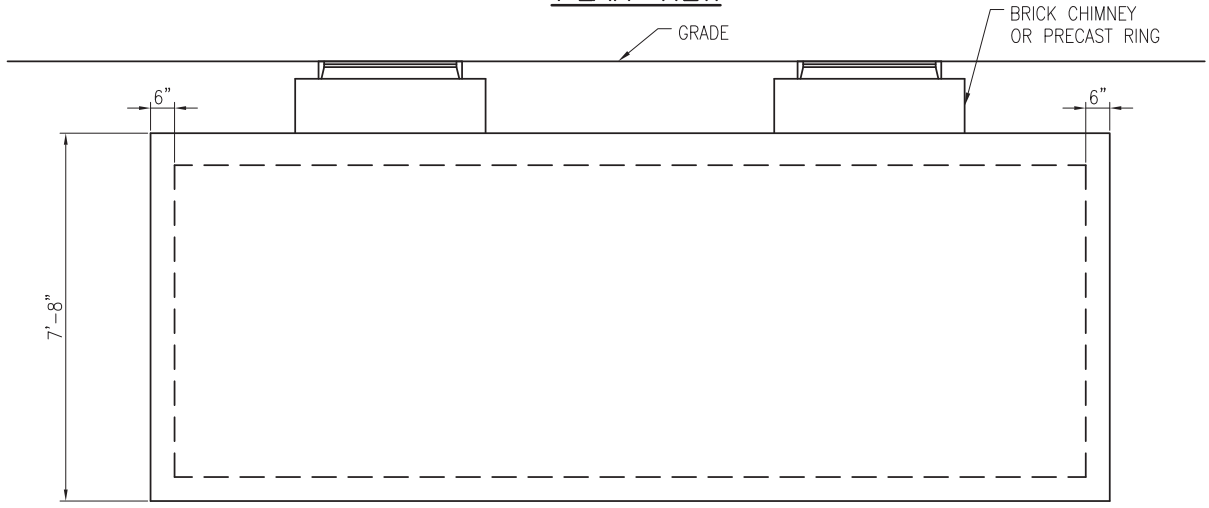

MANHOLE SECTION VIEW
"TYPICAL" NOT FOR CONSTRUCTION

SCALE N.T.S.



Manhole Detail.dwg

REFERENCE DRAWINGS	DSGN	JJS	12/01/2011		DEEPWATER WIND	JOB NUMBER	REV
	DRN	JJS	12/01/2011		BLOCK ISLAND TRANSMISSION PROJECT	119630	△
	CKD	DEJ	12/01/2011		TYPICAL MANHOLE DETAIL		
SCALE:		N.T.S.				Figure 9	
FOR 8.5x11 DWG ONLY							

THIS DRAWING WAS PREPARED BY POWER ENGINEERS, INC. FOR A SPECIFIC PROJECT, TAKING INTO CONSIDERATION THE SPECIFIC AND UNIQUE REQUIREMENTS OF THE PROJECT. REUSE OF THIS DRAWING OR ANY INFORMATION CONTAINED IN THIS DRAWING FOR ANY PURPOSE IS PROHIBITED UNLESS WRITTEN PERMISSION FROM BOTH POWER AND POWER'S CLIENT IS GRANTED.

C	ISSUED FOR REVIEW	02/03/2012	JJS	JJS	DEJ
B	ISSUED FOR REVIEW	01/30/2012	JJS	JJS	DEJ
A	ISSUED FOR REVIEW	01/12/2012	JJS	JJS	DEJ
REV	REVISIONS	DATE	DRN	DSGN	CKD

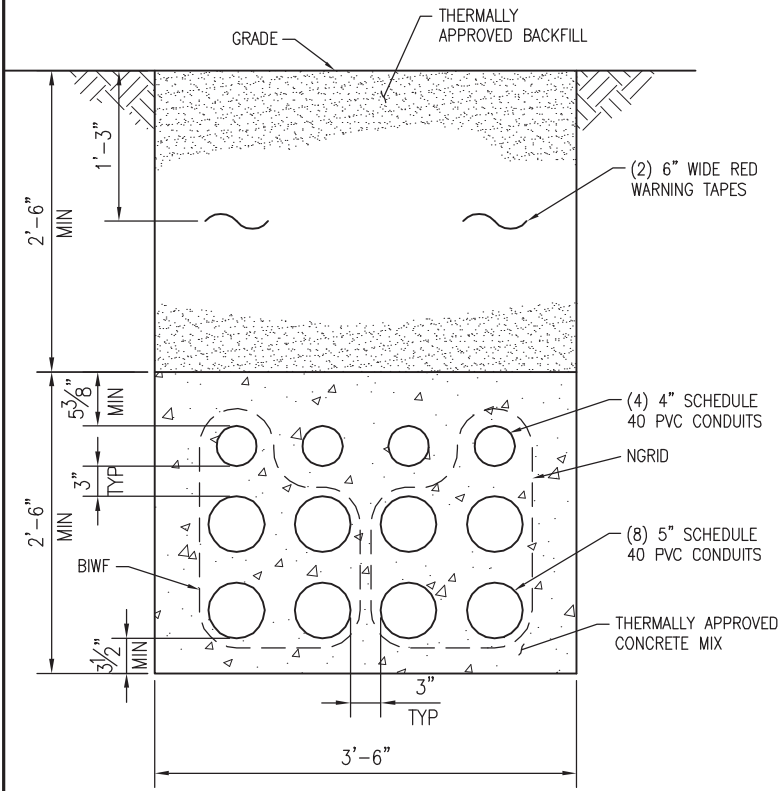

DOUBLE CIRCUIT SECTION
"TYPICAL" NOT FOR CONSTRUCTION
 SCALE N.T.S.

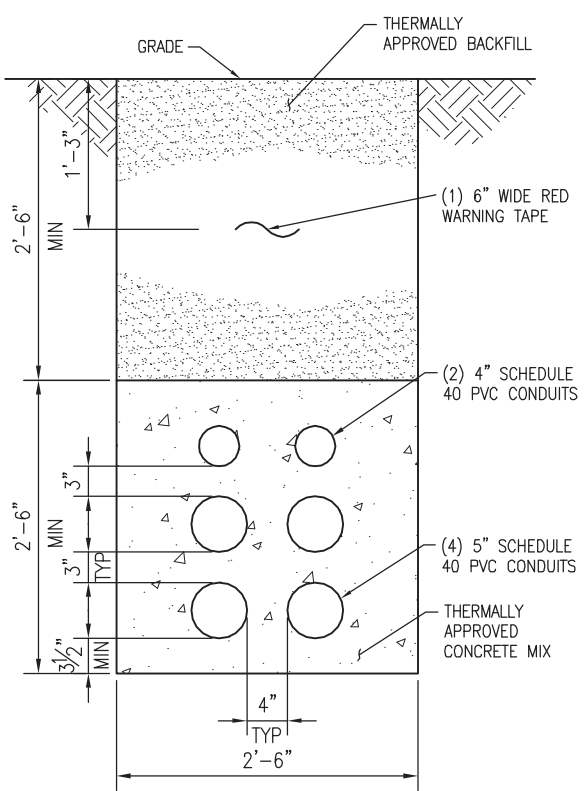

SINGLE CIRCUIT SECTION
"TYPICAL" NOT FOR CONSTRUCTION
 SCALE N.T.S.

TRENCH DETAIL ALUMINUM.dwg



		DSGN	JJS	01/12/2012
		DRN	JJS	01/12/2012
		CKD	DEJ	01/12/2012
		SCALE:	N.T.S.	
			FOR 8.5x11 DWG ONLY	



DEEPWATER WIND	JOB NUMBER	REV
BLOCK ISLAND TRANSMISSION PROJECT	119630	△
TRENCH DETAIL (ALUMINUM)	Figure 10	

THIS DRAWING WAS PREPARED BY POWER ENGINEERS, INC. FOR A SPECIFIC PROJECT, TAKING INTO CONSIDERATION THE SPECIFIC AND UNIQUE REQUIREMENTS OF THE PROJECT. REUSE OF THIS DRAWING OR ANY INFORMATION CONTAINED IN THIS DRAWING FOR ANY PURPOSE IS PROHIBITED UNLESS WRITTEN PERMISSION FROM BOTH POWER AND POWER'S CLIENT IS GRANTED.

D	ISSUED FOR REVIEW	02/14/2012	JJS	JJS	DEJ	
C	ISSUED FOR REVIEW	02/03/2012	JJS	JJS	DEJ	
B	ISSUED FOR REVIEW	01/30/2012	JJS	JJS	DEJ	
A	ISSUED FOR REVIEW	12/30/2011	JJS	JJS	DEJ	
REV	REVISIONS	DATE	DRN	DSGN	CKD	APPD

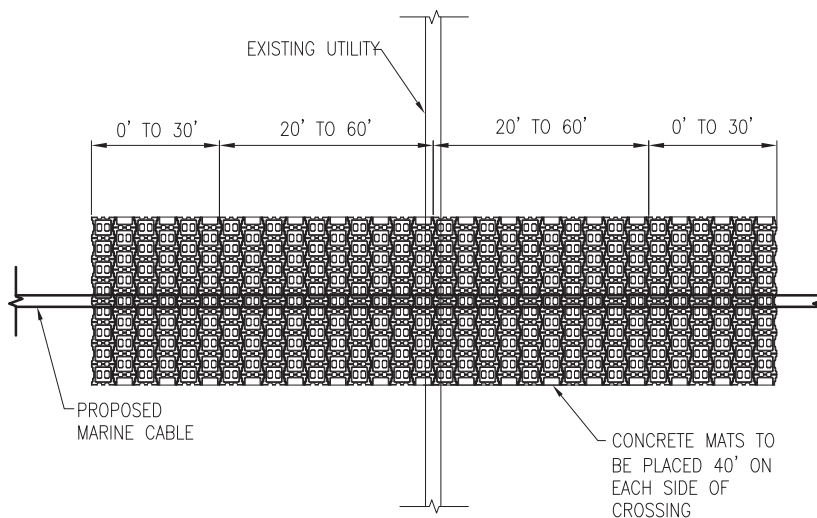

PLAN VIEW

EXISTING UTILITY CROSSING

SCALE N.T.S.

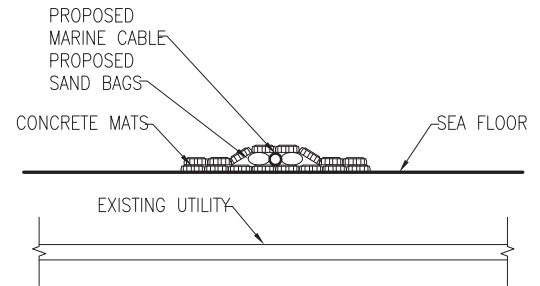

CROSS SECTION

EXISTING UTILITY CROSSING

SCALE N.T.S.

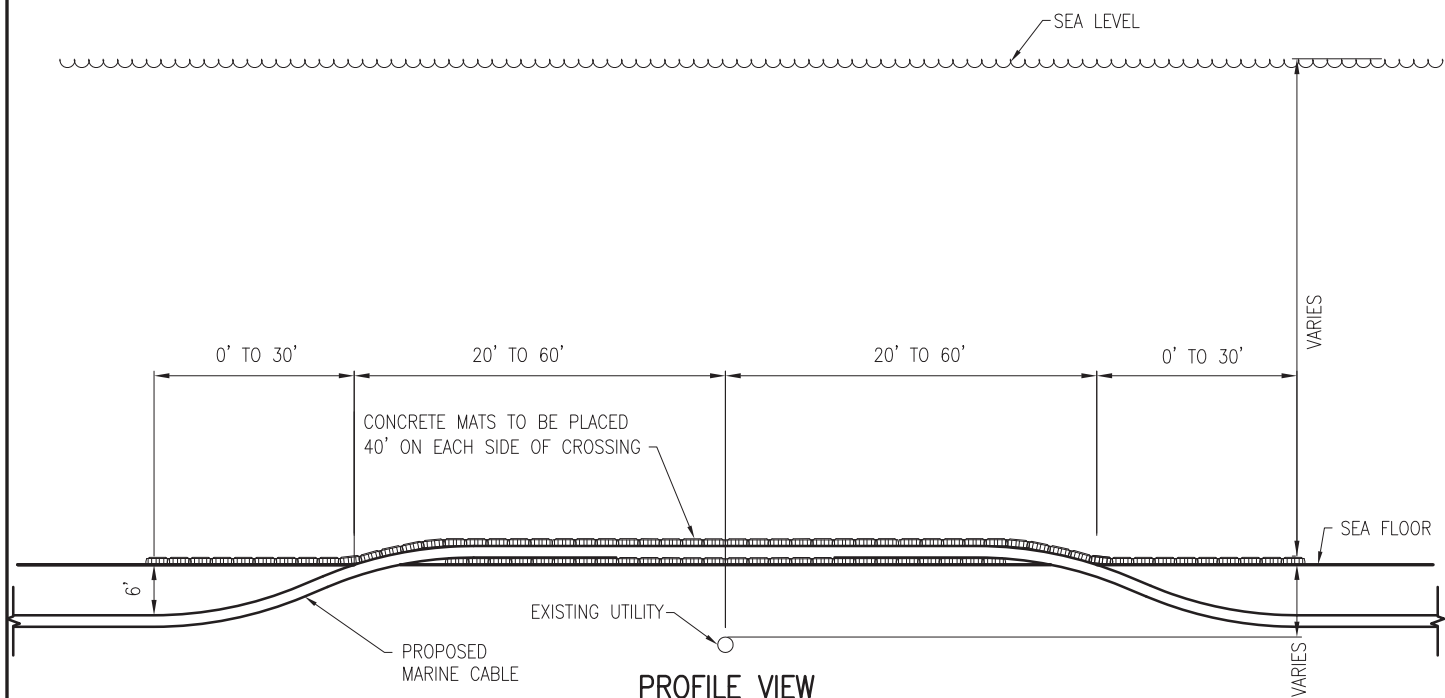

PROFILE VIEW

EXISTING UTILITY CROSSING

SCALE N.T.S.



UTILITY CROSSING.dwg

DSGN	JJS	12/30/2011
DRN	JJS	12/30/2011
CKD	DEJ	12/30/2011
SCALE:	N.T.S.	
FOR 8.5x11 DWG ONLY		



DEEPWATER WIND	JOB NUMBER	REV
BLOCK ISLAND TRANSMISSION PROJECT	119630	D
TYPICAL OCEAN UTILITY CROSSING DETAIL	Figure 13	

DEEPPWATER WIND	JOB NUMBER	REV
	119630	D
Figure 13		

THIS DRAWING WAS PREPARED BY POWER ENGINEERS, INC. FOR A SPECIFIC PROJECT, TAKING INTO CONSIDERATION THE SPECIFIC AND UNIQUE REQUIREMENTS OF THE PROJECT. REUSE OF THIS DRAWING OR ANY INFORMATION CONTAINED IN THIS DRAWING FOR ANY PURPOSE IS PROHIBITED UNLESS WRITTEN PERMISSION FROM BOTH POWER AND POWER'S CLIENT IS GRANTED.

D	ISSUED FOR REVIEW	02/14/2012	JJS	JJS	DEJ	
C	ISSUED FOR REVIEW	02/03/2012	JJS	JJS	DEJ	
B	ISSUED FOR REVIEW	01/30/2012	JJS	JJS	DEJ	
A	ISSUED FOR REVIEW	01/12/2012	JJS	JJS	DEJ	
REV	REVISIONS	DATE	DRN	DSGN	CKD	APPD

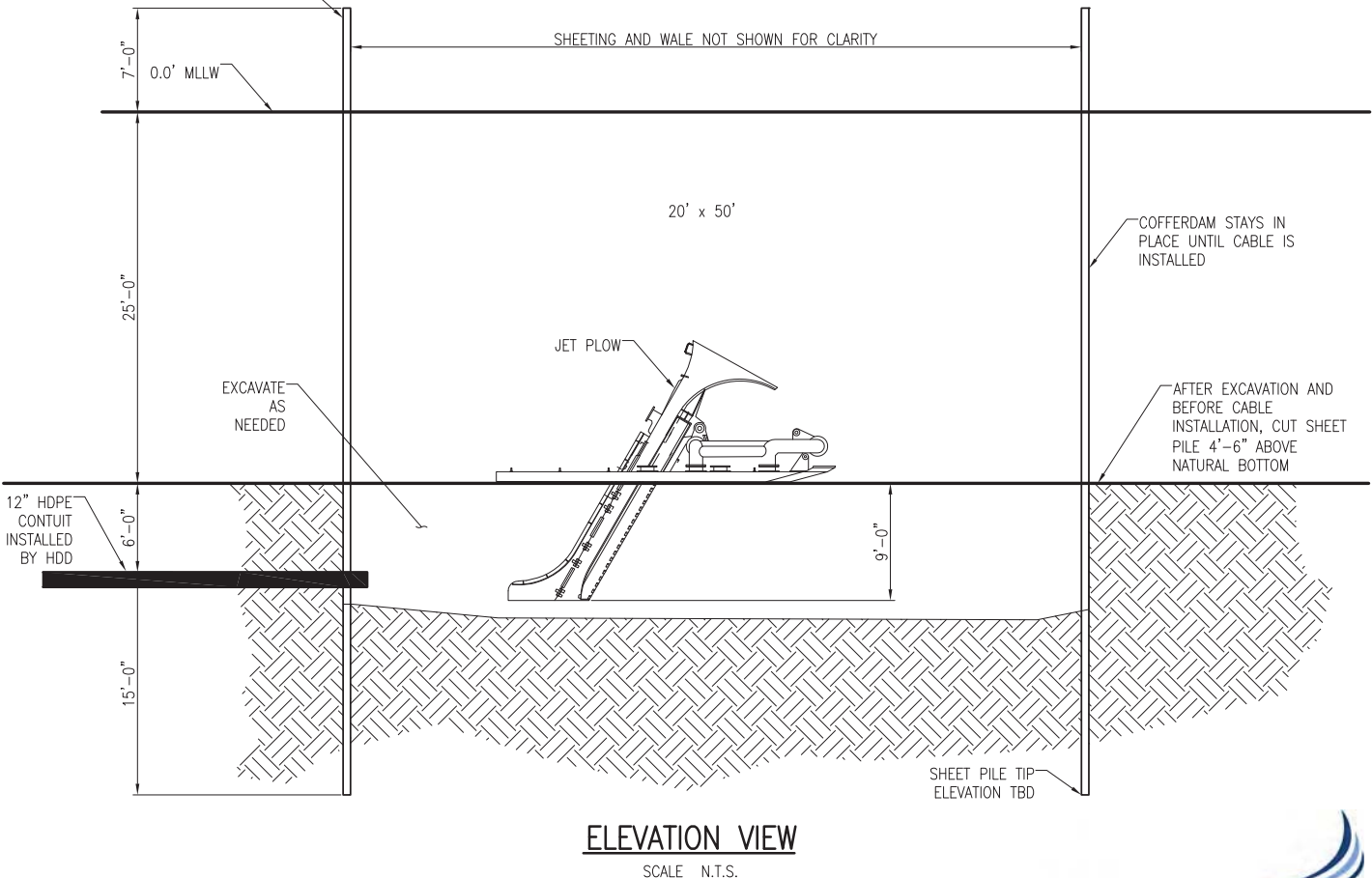
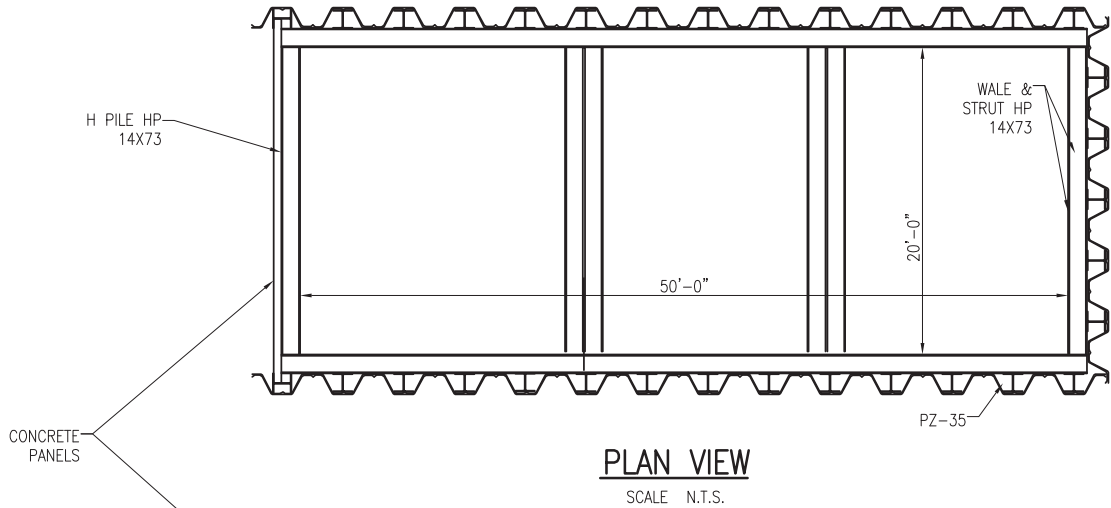

Coffer Dam Detail.dwg



DSGN	JJS	1/12/2012
DRN	JJS	1/12/2012
CKD	DEJ	1/12/2012
SCALE:	N.T.S.	
FOR 8.5x11 DWG ONLY		



DEEPWATER WIND	JOB NUMBER	REV
BLOCK ISLAND TRANSMISSION PROJECT	119630	D
COFFER DAM DETAIL	Figure 14	

JOB NUMBER	REV
119630	D
Figure 14	

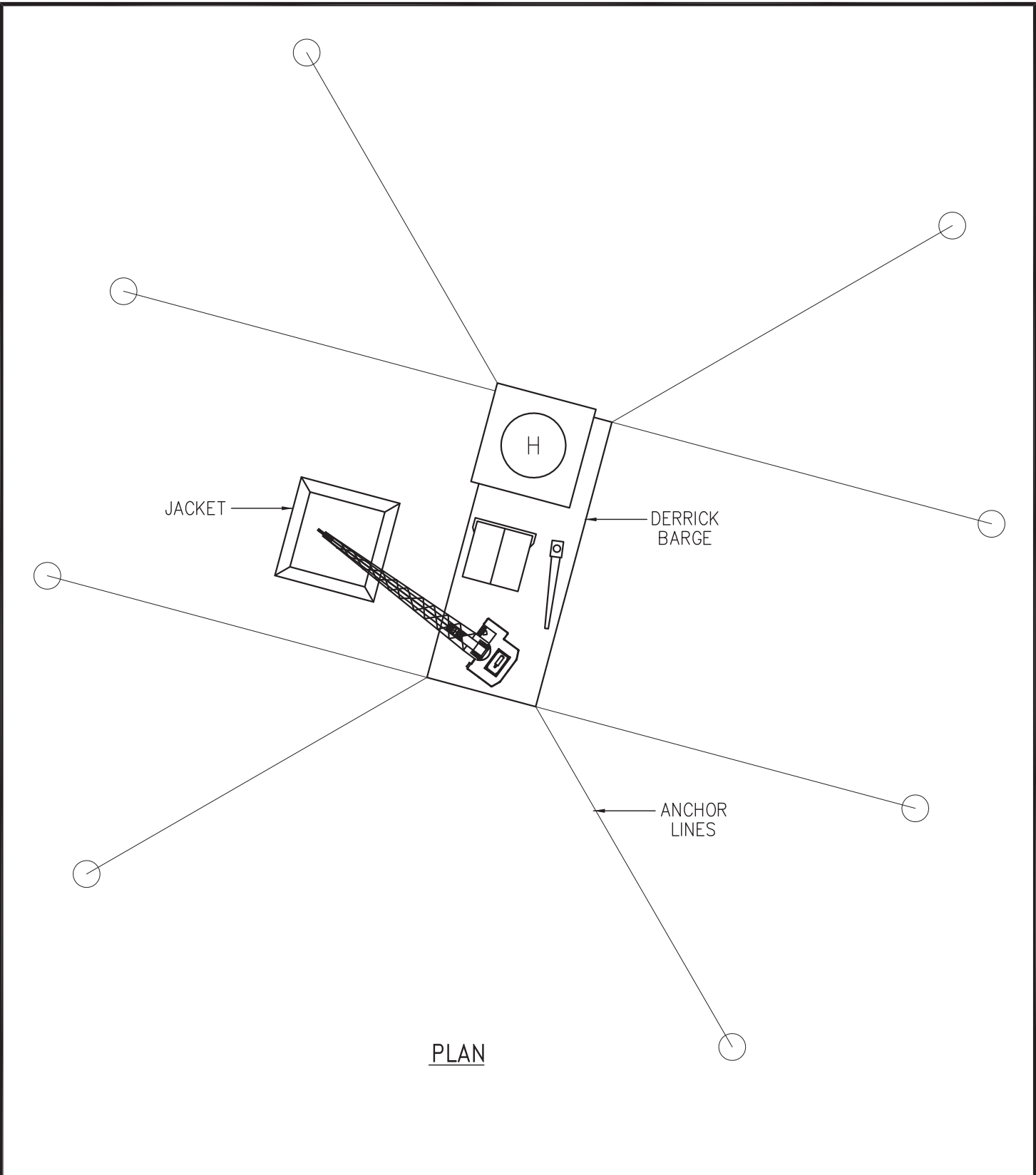

Upstream Engineering LLC

"Providing Value Added Engineering Services"
 HOUSTON, TEXAS www.upstreamengineering.com (281) 531-0047

Registration No.: F-2752

No.	DATE	REVISION	BY	APP.
B	03/15/12	REVISED ISSUED FOR PERMITTING	JR	RS
A	01/24/12	ISSUED FOR PERMITTING	JR	RS

DESIGNED BY: D. YBARRA SCALE: N.T.S.

DRAWN BY: J. RHAME DATE: 01/11/12



DEEPWATERWIND®

**JACKET INSTALLATION
w/DERRICK BARGE**



PROJ. No.: P12-002
 FILENAME: 9004.dwg

Figure 15

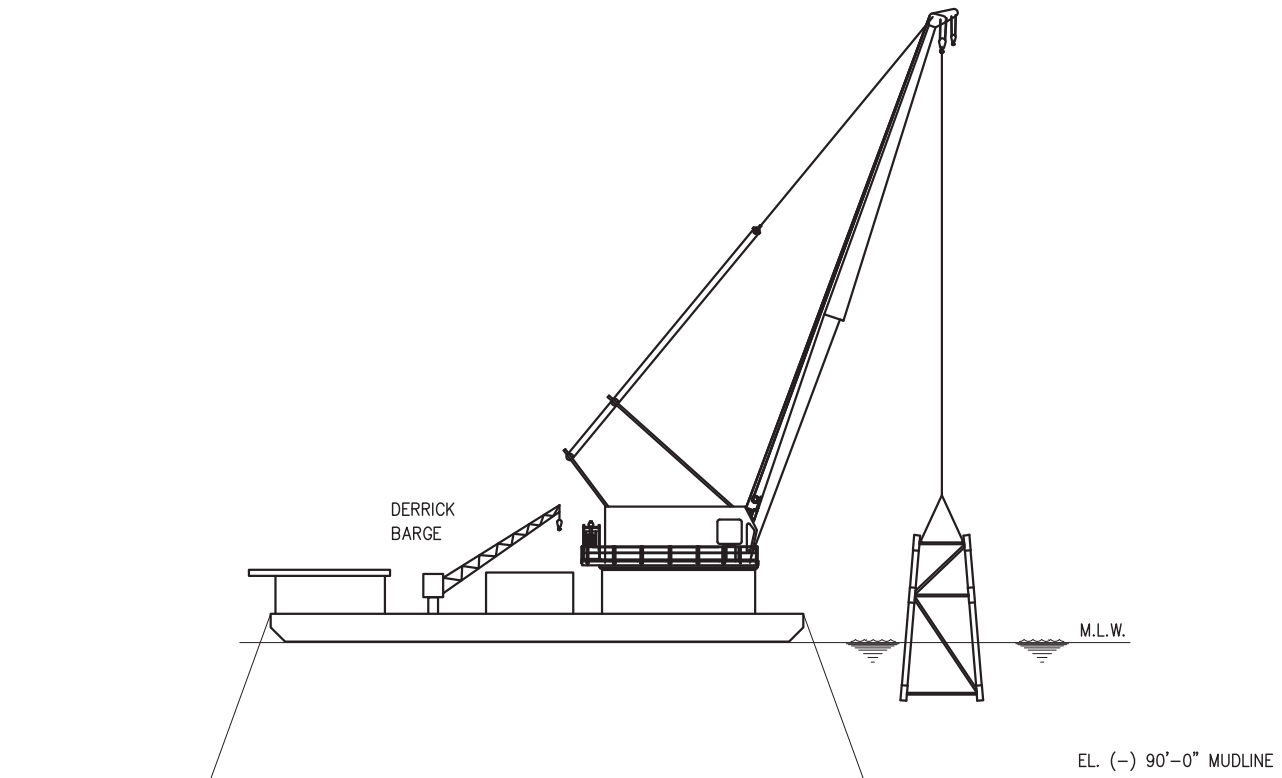
REV. No.: **B**



ELEVATION

 <p>Upstream Engineering LLC "Providing Value Added Engineering Services" HOUSTON, TEXAS www.upstreamengineering.com (281) 531-0047</p>					 <p>DEEPWATERWIND®</p>						
<p>Registration No.: F-2752</p>					<p>JACKET INSTALLATION w/DERRICK BARGE</p>						
C	03/15/12	REVISED ISSUED FOR PERMITTING	JR	RS							
B	01/26/12	REVISED ISSUED FOR PERMITTING	JR	RS							
No.	DATE	REVISION	BY	APP.							
DESIGNED BY: D. YBARRA		SCALE: 1/128"=1'-0"									
DRAWN BY: J. RHAME		DATE: 01/11/12			PROJ. No.: P12-002		Figure 16		REV. No.: C		
					FILENAME: 9005.dwg						

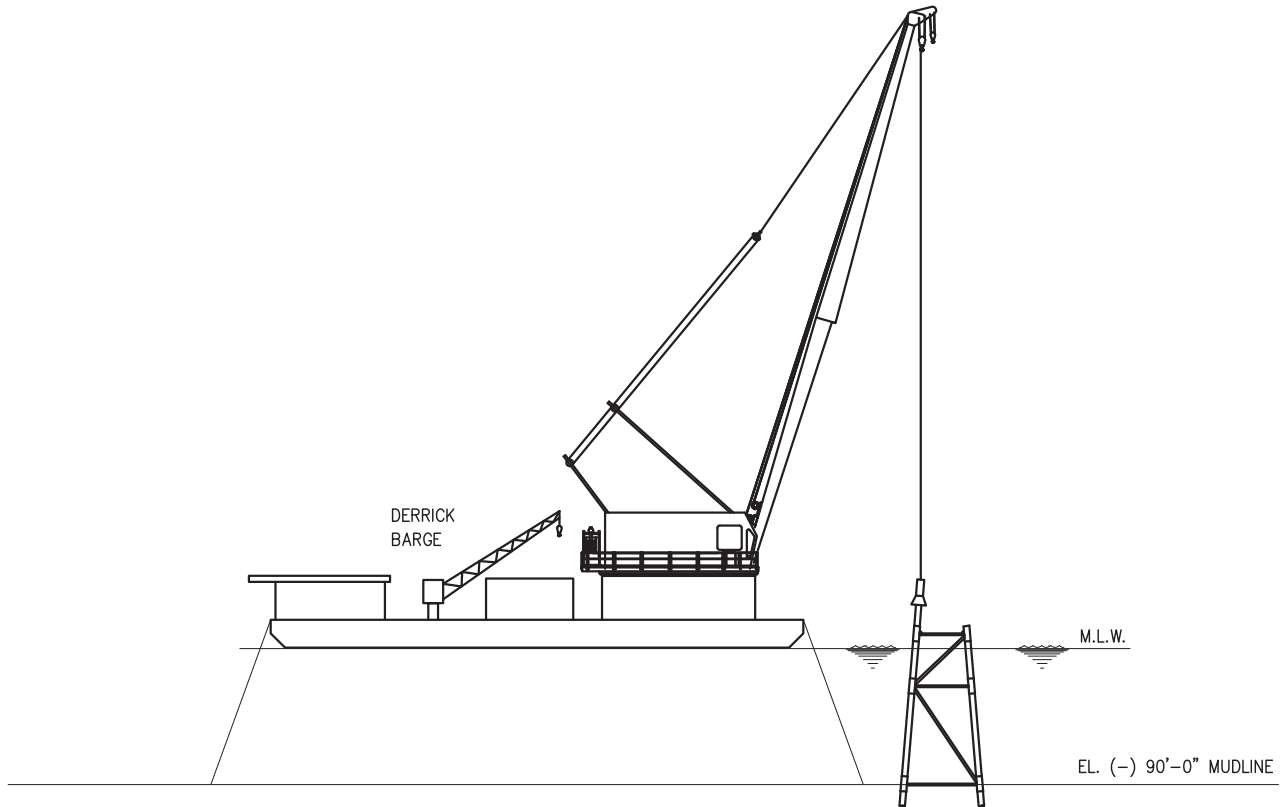

ELEVATION

Upstream Engineering LLC

"Providing Value Added Engineering Services"
 HOUSTON, TEXAS www.upstreamengineering.com (281) 531-0047

Registration No.: F-2752



PILE DRIVING
 w/DERRICK BARGE

No.	DATE	REVISION	BY	APP.
C	03/15/12	REVISED ISSUED FOR PERMITTING	JR	RS
B	01/26/12	REVISED ISSUED FOR PERMITTING	JR	RS

DESIGNED BY: D. YBARRA SCALE: 1/128"=1'-0"

DRAWN BY: J. RHAME DATE: 01/11/12

PROJ. No.: P12-002
 FILENAME: 9006.dwg

Figure 17

REV. No.: C

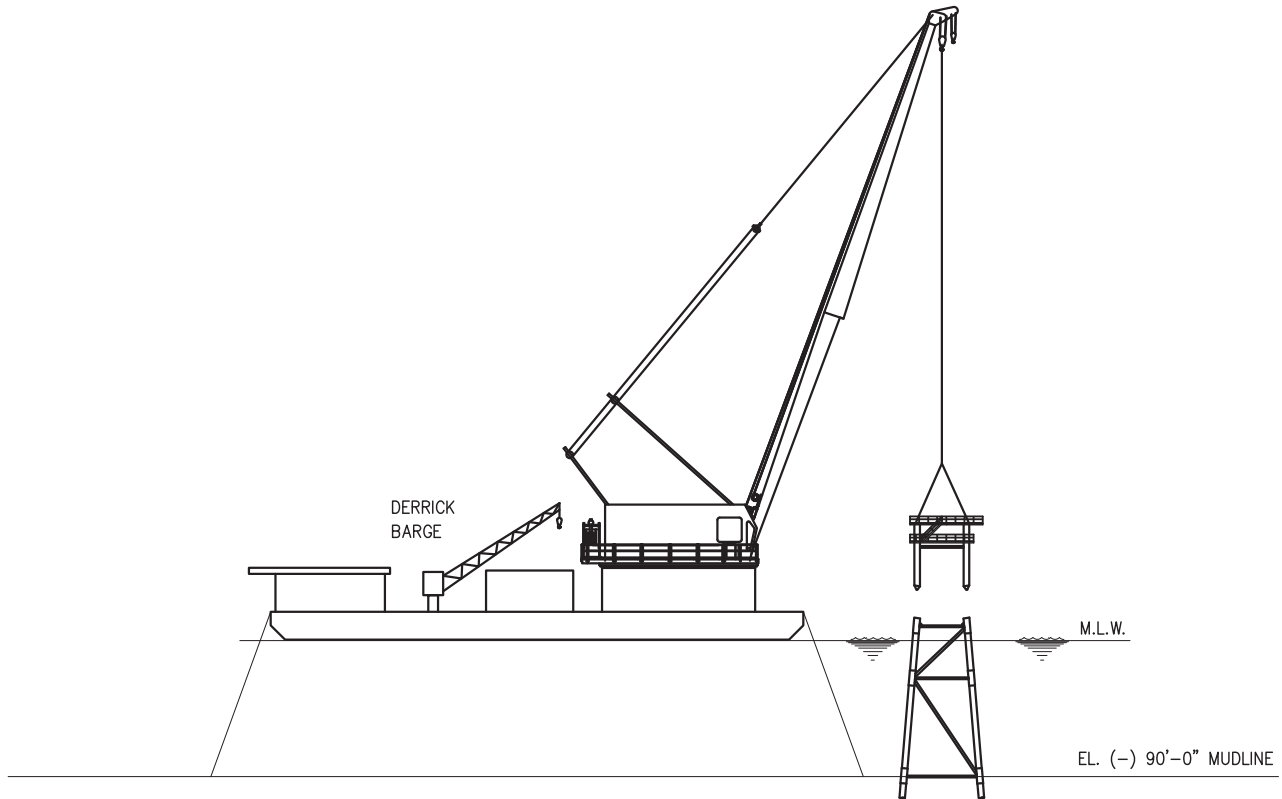

ELEVATION



Upstream Engineering LLC

"Providing Value Added Engineering Services"
 HOUSTON, TEXAS www.upstreamengineering.com (281) 531-0047

Registration No.: F-2752

No.	DATE	REVISION	BY	APP.
B	03/15/12	REVISED ISSUED FOR PERMITTING	JR	RS
A	01/24/12	ISSUED FOR PERMITTING	JR	RS

DESIGNED BY: D. YBARRA SCALE: 1/128"=1'-0"

DRAWN BY: J. RHAME DATE: 02/02/12



DECK INSTALLATION
w/DERRICK BARGE

PROJ. No.: P12-002
 FILENAME: 9007.dwg

Figure 18

REV. No.: B

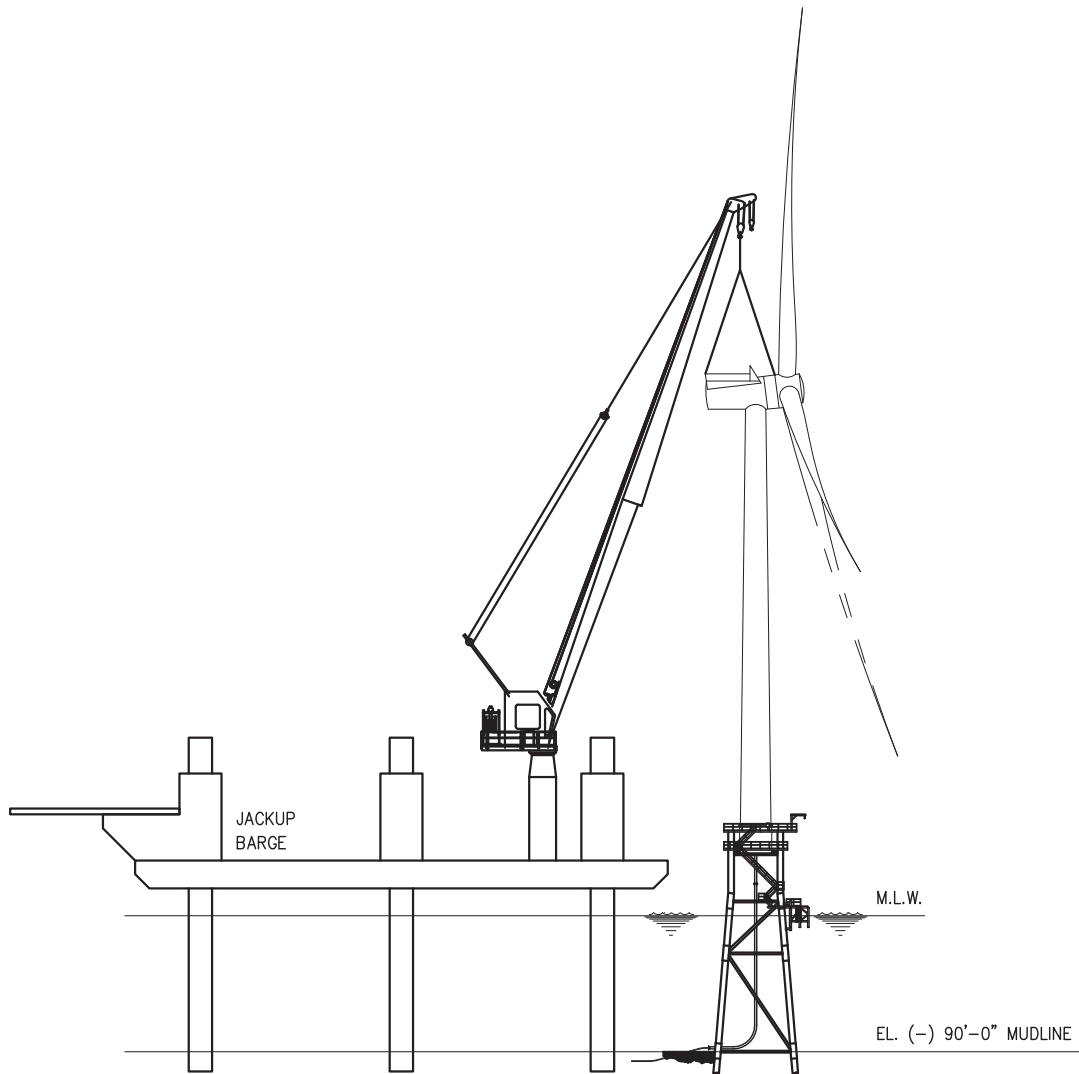

ELEVATION

Upstream Engineering LLC

"Providing Value Added Engineering Services"
 HOUSTON, TEXAS www.upstreamengineering.com (281) 531-0047

Registration No.: F-2752



**TURBINE INSTALLATION
 w/JACKUP BARGE**

No.	DATE	REVISION	BY	APP.
B	03/15/12	REVISED ISSUED FOR PERMITTING	JR	RS
A	01/24/12	ISSUED FOR PERMITTING	JR	RS

DESIGNED BY: D. YBARRA SCALE: 1/128"=1'-0"

DRAWN BY: J. RHAME DATE: 01/11/12

PROJ. No.: P12-002
 FILENAME: 9008.dwg

Figure 19

REV. No.: **B**

Appendix G: September 2018 (Survey 5) Bathymetry Survey Technical Report

FUGRO

**Seafloor Disturbance and Recovery Monitoring Program
Survey 5 September 2018
Block Island Wind Farm, USA**

Fugro Job No.: 02.81150001

Task Order No. 03, 0000023102

August 23, 2019

HDR Environmental, Operations and Construction, Inc.



Document Number: 02.81150001-5

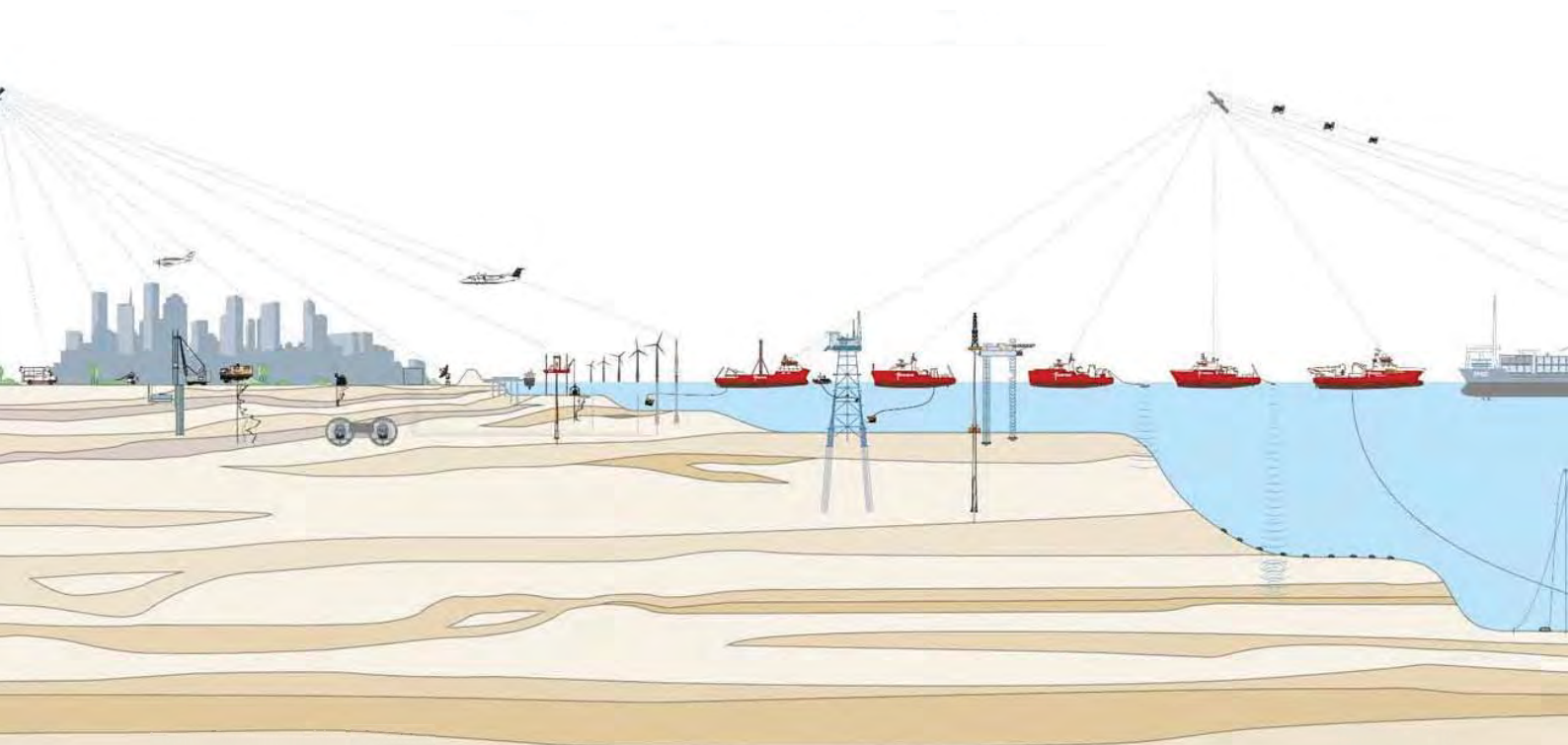



**Seafloor Disturbance and Recovery
Monitoring Program Survey 5
September 2018**
Block Island Wind Farm, USA

August 23, 2019

Fugro Job No.: 02.81150001

Task Order No.: 10, 0000023102

Prepared for: HDR
300 North Madison Street
Athens, Alabama 35611
USA



02	Revised Complete	WBC	KRS	KRS	August 23, 2019
01	Complete	TRW	WBC	KRS	January 15, 2019
Issue	Report Status	Prepared	Checked	Approved	Date

CONTENTS

1.	INTRODUCTION	1
1.1	Real-Time Opportunity for Development Environmental Observations (RODEO) Program	1
1.2	Seafloor Disturbance and Recovery Monitoring	1
1.3	Block Island Wind Farm	1
1.3.1	2015 Construction Season	2
1.3.2	2016 Construction Season	2
1.4	Purpose and Scope	2
1.4.1	Cable Trench Recovery Monitoring	3
1.5	Authorization	3
2.	DATA COLLECTION, PROCESSING, AND INTERPRETATION METHODS	4
2.1	Survey Overviews	4
2.2	Hydrographic Surveys	4
2.2.1	Data Variability and Repeatability	5
2.3	Data Quality	5
2.4	Multibeam Backscatter Data	6
3.	MULTI-TEMPORAL ANALYSIS OF SEAFLOOR CHANGE	7
3.1	Seafloor Disturbance Features	7
3.1.1	Wind Turbine Generator 1	8
3.1.2	Wind Turbine Generator 2	8
3.1.3	Wind Turbine Generator 3	8
3.1.4	Wind Turbine Generator 4	9
3.1.5	Wind Turbine Generator 5	9
3.2	Seafloor Disturbance Recovery	9
3.2.1	Wind Turbine Generator 1	11
3.2.2	Wind Turbine Generator 2	12
3.2.3	Wind Turbine Generator 3	13
3.2.4	Wind Turbine Generator 4	14
3.2.5	Wind Turbine Generator 5	14
3.2.6	Recovery from Seafloor Disturbance Elsewhere in the Work Area	14
3.2.7	Cable Trench Monitoring	15
3.2.8	Seafloor Recovery Rates	16
4.	SUMMARY	19
5.	REFERENCES	22



LIST OF TABLES

Table 1.1: Summary of Construction Activities and Surveys	2
Table 2.1: Comparison of Elevation Measurements	5
Table 3.1: Summary of Seafloor Recovery	10
Table 3.2: Area of Disturbance within 175 meters of Each Turbine	11
Table 3.3: Summary of Cable Trench Recovery	16
Table 3.4: Seafloor Recovery per Zone	18

LIST OF FIGURES

Study Area	1
Fugro September 2018 Bathymetry	2a
Interpreted Seafloor Disturbance Features	2b
Wind Turbine No. 1 Bathymetry & Seafloor Disturbances	3a, 3b, 3c, 3d
Wind Turbine No. 2 Bathymetry & Seafloor Disturbances	4a, 4b, 4c, 4d
Wind Turbine No. 3 Bathymetry & Seafloor Disturbances	5a, 5b, 5c, 5d
Wind Turbine No. 4 Bathymetry & Seafloor Disturbances	6a, 6b, 6c, 6d
Wind Turbine No. 5 Bathymetry & Seafloor Disturbances	7a, 7b, 7c, 7d
Wind Turbine Generators Bathymetry Comparison	8
Wind Turbine No. 1 Recovery Profile	9a
Wind Turbine No. 1 Recovery Profile (Concrete Mattresses)	9b
Wind Turbine No. 2 Recovery Profile	10a
Wind Turbine No. 2 Recovery Profile (Concrete Mattresses)	10b
Wind Turbine No. 3 Recovery Profile	11
Wind Turbine No. 4 Recovery Profile	12
Inter-Array Cable Comparison	13
Surficial Sediment Mobility Comparison	14
Interpreted Seabed Recovery Rates	15
Fugro MBES Backscatter	16

LIST OF CHARTS

Fugro Bathymetric Survey (September 2018)	1
Fugro Bathymetric Survey Interpreted Features (September 2018)	2
Seafloor Disturbance Feature Catalogue (Survey 4-October 2017)	3
Seafloor Disturbance Feature Catalogue (Survey 3-May 2017)	4
Seafloor Disturbance Feature Catalogue (Survey 2-October 2016)	5
Seafloor Disturbance Feature Catalogue (Survey 1-May 2016)	6
Export Cable/Block Island Transmission Cable Recovery	7
Fugro Bathymetric Survey Interpreted Features Per Survey	8
Fugro MBES Backscatter	9



APPENDICES

APPENDIX A: BATHYMETRIC SURVEY DATA ACQUISITION AND PROCESSING

Caris Swath Editor A-1
Caris Swath Subset Editor A-2
Vessel Offset Diagram for the R/V *Westerly* A-3

APPENDIX B: INSTALLATION VESSEL SPECIFICATIONS

L/B *Michael Eymard* Specifications B-1
L/B *Brave Tern* Specifications B-2

APPENDIX C: CATALOG OF SEAFLOOR DISTURBANCE FEATURES

Seafloor Disturbance Features (Construction Season 1 and 2) C-1

APPENDIX D: TYPICAL TURBINE AND PLATFORM CONSTRUCTION DRAWINGS

1. INTRODUCTION

1.1 Real-Time Opportunity for Development Environmental Observations (RODEO) Program

The United States (U.S.) Department of Interior's Bureau of Ocean Energy Management (BOEM) is responsible for managing the exploration and development of the nation's offshore energy resources. The BOEM conducts environmental reviews, including National Environmental Policy Act (NEPA) analyses, for each major stage (leasing, site assessment, construction, operations, and decommissioning) of proposed offshore energy development projects. Through these reviews and analyses, the BOEM evaluates potential environmental impacts from the proposed offshore activities on the human, coastal, and marine environments. The NEPA analysis is used to inform the decision-making process for whether and/or how to proceed with the approval of the offshore energy development.

To conduct the required analyses and effectively analyze the potential environmental impacts under NEPA, the BOEM requires data on impact-producing factors (stressors) and their effects on ecosystems and individual receptors. Development of offshore wind energy is new to the U.S.; therefore, data necessary for assessment of environmental impacts are not readily available. Thus, the BOEM has initiated the Real-Time Opportunity for Development Environmental Observations (RODEO) Program. The purpose of this program is to make direct, real-time measurements of the nature, intensity, and duration of potential stressors during the construction and/or initial operations of selected offshore wind facilities.

Data collected under the RODEO Program may be used as input to analyses or models that are employed to evaluate effects or impacts from future offshore activities. The first facility to be part of the RODEO Program monitoring is the Block Island Wind Farm (BIWF) Project, which is located off the coast of Rhode Island.

1.2 Seafloor Disturbance and Recovery Monitoring

The seafloor can be disturbed by various activities during the construction and operational phases of a wind farm development. During construction and/or maintenance, vessel anchoring activities and spud can penetrations may result in depressions in the seafloor. In addition, while a lift boat is positioned on site, scour can develop around the legs that penetrate the seafloor. Evidence of those impacts on the environment can disappear as sediment is reworked and transported due to natural processes after construction equipment is removed from the seafloor. The recovery rate from a seafloor disturbance primarily depends on sediment type, bottom current flow conditions (e.g. speed, duration, direction, etc.), and size of the disturbance feature.

This study utilizes repeated bathymetric surveys for use as a multi-temporal analysis tool to monitor for disturbance and recovery of the seafloor.

1.3 Block Island Wind Farm

Deepwater Wind (DW) recently constructed the BIWF, which is located approximately five kilometers (km) southeast of Block Island, Rhode Island. The BIWF is comprised of five wind turbine generators with a name-plate capacity of 30 megawatts (MW). Figure 1 presents the location of the BIWF and survey area. The BIWF was constructed during two construction seasons as described in the following sections.



1.3.1 2015 Construction Season

During 2015, DW installed foundations for the five wind turbine generators (WTGs). The lift boats used to install the WTG foundations were the L/B *Robert*, L/B *Lacie Eymard*, and the L/B *Michael Eymard*. The foundations installed are four-legged jackets that used 1524-millimeter (60-inch) diameter piles. Appendix D provides typical construction drawings of the foundations. Construction activities occurred from late spring 2015 through December 2015.

1.3.2 2016 Construction Season

Construction activities during the 2016 season included installing the towers, nacelles, blades, inter-array cable, export cable, and finishing works on the foundations. Towers, nacelles, and blades were installed using Fred Oslen’s L/B *Brave Tern*. Foundation works were performed during May and June 2016. Cabling was installed during June and July using a jet trenching technique. The L/B *Brave Tern* installed the towers, blades and nacelles during July and August. Final cable pulls into the turbines, concrete mats and ancillary works were performed in September. Concrete mattresses were placed where the cable installation did not reach the desired burial depths. In areas near the WTGs, the cable was intentionally left unburied until the final cable pull into the turbine was performed. After the pull, concrete mats were placed on the short section of exposed cable on the seafloor near each turbine. Appendix D provides typical construction drawings that depict the various cable and turbine installation details and methods.

1.4 Purpose and Scope

The Seafloor Disturbance and Recovery Monitoring Study utilized periodic bathymetric surveys to identify seafloor disturbance features and monitor seafloor recovery from the disturbances. The survey extent encompassed the area denoted by DW as the “Work Area.” The Work Area was the primary area where construction vessels were positioned during construction. Table 1.1 provides a summary of the various construction activities and bathymetric surveys conducted as part of the monitoring program.

Table 1.1: Summary of Construction Activities and Surveys

Time	Activity
Construction Season 1 Late Spring through December 2015	Installation of Jacket Foundations
May 11 and 12, 2016	Survey 1 (Construction Season 1 Baseline Survey)
Construction Season 2 May through September 2016	<ul style="list-style-type: none"> ▪ Installation of tower, nacelles, and blades ▪ Installation of inter-array and export cables <ul style="list-style-type: none"> ▪ Ancillary foundation works
October 2 to 5, 2016	Survey 2 (Construction Season 2 Baseline Survey)
May 18 and 19, 2017	Survey 3
October 2 and 3, 2017	Survey 4
September 29 and 30, 2018	Survey 5 (Current Report)

Fugro (2016, 2017a, 2017b, and 2017c)

This report presents the findings of the fifth bathymetric survey conducted by Fugro at the BIWF during September 29 and 30, 2018. The multibeam data from previous bathymetry surveys of the area (conducted by Fugro on May 11 and 12, 2016, October 2 to 5, 2016, May 18 and 19, 2017, and October

2 and 3, 2017) were compared to the September 2018 data to evaluate seafloor recovery from disturbances created during the 2015 and 2016 Construction Seasons.

1.4.1 Cable Trench Recovery Monitoring

Installation of cables (June-July 2016) using jet-trenching techniques utilize high-pressure water discharged from the jet-trencher to fluidize the sediments, thus excavating a trench that the cable falls into and is subsequently buried by the fluidized sediments suspended momentarily in the water column. After laying the cable, a trench scar (slight topographic depression created since not all of the fluidized sediments deposit back in the trench footprint) is usually visible for some time after installation. In most cases, reworking of the seafloor sediments buries the trench and the trench is no longer visible. The length of time it takes for this seafloor recovery to occur depends largely upon seafloor sediment type and bottom current characteristics (e.g. speed, duration, and direction).

Jet-trenching also causes the fluidized sediments that redeposit in the trench to generally be in a looser state than the undisturbed neighboring sediments. The looser, back-filled sediments may be more easily transported by bottom-currents and result in erosion of the trench backfill materials (Fugro, 2012).

The primary objective of the seafloor disturbance monitoring program is to monitor in the wind turbine construction area (the Work Area). However, during some of the surveys we took advantage of opportunities to collect data along the cable route to support assessments of cable trench recovery when time allowed. This report presents results from those partial cable route surveys.

1.5 Authorization

Authorization for this work was provided by HDR Master Service Agreement No. MSA2015-1165, under task order TO 007, 1000300000862 and Modification No.1, between HDR and Fugro, dated August 2, 2017 and January 29, 2018, respectively.



2. DATA COLLECTION, PROCESSING, AND INTERPRETATION METHODS

2.1 Survey Overviews

During September 29 and 30, 2018, Fugro conducted the fifth hydrographic survey (Survey 5) of the Work Area surrounding the five Block Island wind turbines. Figures 1 and 2a and Chart 1 show the extent of the hydrographic survey. Survey 5 encompassed the same area that was surveyed during Survey 1 on May 11 and 12, 2016, Survey 2 on October 2 to 5, 2016, Survey 3 on May 18 and 19, 2017, and Survey 4 on October 2 and 3, 2018. All hydrographic surveys were conducted using a pole-mounted multibeam echosounder aboard a small research vessel. A detailed description of the survey vessel, instrument offsets, calibration tests, data acquisition and processing methods are provided in Appendix A of this report. Table 1.1 provides a summary of the surveys and phases of construction.

2.2 Hydrographic Surveys

The Construction Season 1 (2015) baseline survey was conducted in May 2016 and the results from that survey were provided in the Survey 1 report. Survey 1 was conducted using the chartered vessel R/V *Jamie Hanna*. The R/V *Jamie Hanna* is a 55-foot long purpose-built survey vessel. Surveys 2 through 5 were conducted using the chartered vessel R/V *Westerly*. The R/V *Westerly* is a 50-foot long purpose-built, catamaran style survey vessel (Appendix A, Figure A-3). Surveys 2 through 5 were conducted in October 2016, May 2017, October 2017, and September 2018 respectively. Survey 2 represents the Construction Season 2 baseline survey. This report describes the data acquisition, processing and evaluation of the data from Survey 5.

The survey vessels were equipped with a pole-mount for the echosounder transducers. All the hydrographic surveys were conducted at speeds ranging from four to seven knots. Survey 5 was conducted using a R2Sonic Sonic 2024 high-resolution multibeam echosounder (designed to operate in water depths ranging from 0.5 meters to 200 meters). The nominal vertical resolution of post-processed data is likely approximately 10 centimeters (depending on sea state, tidal error, seafloor gradient, sounding position along track, and other factors).

Multibeam data from the surveys were collected in WinFrog software and were visually monitored during the survey for quality assurance. The WinFrog *.s7k files were then brought into CARIS for bathymetric processing. Subsequently, corrections for vessel offsets, patch test calibration, and static draft measurements were input into the software. Sound Velocity Profiles (SVPs) were then used to correct the bathymetric data for sound refraction or ray bending.

After each line was examined and cleaned in CARIS' Swath Editor, the tide corrections were loaded and the lines were merged. The merged dataset was then examined to identify tidal discrepancies, sound velocity errors, motion errors, and data gaps. Once all processing was completed, a digital terrain model (DTM) was generated with CARIS at a 0.5 meter bin size. The ASCII XYZ grid file of easting, northing, and depth values in meters was then output from CARIS for interpretation.

All data from all the surveys were projected in metric measurement (meters) with the Universal Transverse Mercator (UTM) Zone 19 North coordinate system, using the World Geographic System of 1984 (WGS84) geodetic datum. The real-time navigation and position data were used as the geodetic control, receiving differential global navigation satellite system (GNSS) corrections via a G2 subscription to Fugro's OmniStar service. All real-time positioning data were converted to WGS84 (g1150) using an



Applanix POS MV positioning system. This real-time positioning was used to process the multibeam survey lines. Horizontal positioning error at the vessel's common reference point (CRP) is estimated to be less than one meter (during optimal conditions).

Bathymetric data from all the surveys were reduced to mean lower low water (MLLW) based on the National Oceanic and Atmospheric Administration (NOAA) VDatum model (<http://vdatum.noaa.gov>). This model provides separation values from the GNSS ellipsoid down to the chart datum of MLLW for the survey area. These values were then applied to the bathymetry using the CARIS HIPS Compute GPS Tide routine.

2.2.1 Data Variability and Repeatability

Samples of water depth values from a selected area within the BIWF that was interpreted to undergo no significant seafloor change between the four surveys were used to establish a baseline degree of variability between the four surveys. The elevation difference between the surveys was obtained by extracting data within the analysis area and then subtracting values on a bin node-by-node basis. The results are summarized in Table 2.1.

Table 2.1: Comparison of Elevation Measurements

Statistic	May 2016 / Sep. 2018 Comparison	Oct. 2016 / Sep. 2018 Comparison	May 2016 / Sep. 2018 Comparison	Oct. 2017 / Sep. 2018 Comparison
Analysis area size (square meters)	120,610	120,610	120,610	120,610
Minimum Difference (meters)	-0.24	-0.16	-0.22	-0.18
Maximum Difference (meters)	0.23	0.21	0.22	0.20
Mean Difference (meters)	0.03	0.03	0	0.03
Standard Deviation (meters)	±0.05	±0.05	±0.05	±0.05

An average systematic bias of 0.05 meters was observed in the sample set that can likely be attributed to tidal error, subtle boat draft discrepancies, and normal limitations associated with multibeam head calibration. Significant systematic bias can also be attributed to survey line direction. In addition, some components of random variability are evident in the sample set and are likely due to sea state, horizontal positioning uncertainty, and other factors. If the assumption of no bathymetric change for the benchmark area is valid, the standard deviation (±0.05 meters) reflects the uncertainty of vertical difference calculated for the five surveys and can be used to help identify areas likely to be of significant seafloor change across the BIWF study area. Seafloor difference values greater than two standard deviations (±0.1 meters) are interpreted to represent bathymetric change that is likely (at the 95 percent confidence interval) to be significant with respect to the data limitations of the surveys.

2.3 Data Quality

Sea states during the May 2016 survey were relatively calm, resulting in fair raw data quality. Minimal data processing was required to generate bathymetric deliverables that were relatively free of motion artifacts and other surface noise. Sea states during the October 2016 were fair to marginal. Quality of the raw data collected during the October 2016 survey was reported to be affected by the marginal sea states and motion artifacts were noted on the outer portions of the bathymetric swath. Post-acquisition data processing resulted in final deliverables of good quality; however, some motion related artifacts are still observable in the final DTM but the data are deemed adequate for meeting the study's objectives. Data quality for the raw data collected for the May 2017 survey was reported to be affected by some motion in the moonpool at the time of the survey; however, the overall data quality was good and post-

acquisition data processing resulted in final deliverables of good quality. Similarly, the data quality collected for the October 2017 survey was degraded slightly by vessel motion at the time of the survey, but the overall data quality was good. Sea states during the September 2018 survey were fair to marginal. Some subtle linear motion artifacts are present in the DTM and tidal offsets of approximately 5 to 10 cm between swaths are present, but the data were deemed as adequate for meeting the study's objectives.

2.4 Multibeam Backscatter Data

Multibeam backscatter data are used to evaluate seafloor conditions and habitat type. Backscatter data are related to sediment grain size and seafloor roughness and provide qualitative and quantitative information on the composition of the seafloor.

Multibeam backscatter data were collected using the R2Sonic 2024 Multibeam Echosounder. Multibeam backscatter data have been processed from Surveys 3, 4, and 5 and have been used to support the interpretation of sediment types, bedforms, and changes in the seafloor conditions. Limited grain size data (e.g. grab samples collected during RODEO's Benthic Monitoring Program near WTGs 1, 3, and 5) and limited seafloor sediment type information from Deepwater Wind reports were available and incorporated in the evaluation of the backscatter data. Figure 16 and Chart 9 present backscatter data collected during Survey 5.

3. MULTI-TEMPORAL ANALYSIS OF SEAFLOOR CHANGE

This study is performing a multi-temporal analysis to identify seafloor disturbances related to wind farm construction activities and monitor the recovery from those seafloor disturbances. High-resolution bathymetric data acquired during periodic surveys are being analyzed to evaluate the seafloor changes.

The BIWF was constructed during two separate construction seasons (Construction Season 1 in 2015 and Construction Season 2 in 2016, respectively). The “Work Area,” as designated by DW, was the primary area where construction vessels were positioned during construction. The bathymetric surveys encompass the Work Area delineated as the Survey Area displayed in Figure 1. This report describes the results from the fifth survey which evaluates the recovery from disturbances created during Construction Season 1 (2015) and Construction Season 2 (2016).

3.1 Seafloor Disturbance Features

Multibeam bathymetry data acquired during the survey were processed, rendered and evaluated to identify seafloor disturbance features inferred to be related to construction activities. Processed multibeam data were interpolated to create a DTM with a 0.5-meter bin size as described in Section 2.2. Sun-illuminated, hillshaded-relief renderings of the seafloor DTM were also created to enhance seafloor features and aid in visually identifying seafloor disturbances. Interpreted seafloor disturbance features are classified based on the following:

- Spud: Circular or rectangular depressions arranged in a pattern that match one of the lift boats and are generally located near a WTG. Likely created when a lift boat was on position during installation of the turbine.
- Circular Depression: Circular depression not associated with a geometric pattern that would have been created when a lift boat was on position and had all 3 or 4 legs deployed. Circular depression was generally located away from WTG position and may be related to a spud depression or anchor drop.
- Drag Mark: Elongated or linear disturbance feature likely created from the dragging of a spud leg or anchor.
- Scour: Scour feature that formed around the leg of the jacket foundation or around the concrete mat cable protection.

Figure 2b and Chart 2 presents the locations and classifications of the seafloor disturbance features from Construction Season 1 (2015) and Construction Season 2 (2016) that were still visible in Survey 5 (September 2018). Figures 3 through 7 present a series of maps focused on each turbine area. The information presented on each respective series includes:

- “a” series (Figures 3a, 4a, ...) - Bathymetric contours,
- “b” series (Figures 3b, 4b, ...) - Interpreted disturbance features symbolized based on type of feature, and
- “c” series (Figures 3c, 4c, ...) - Interpreted disturbance features symbolized based on the associated Construction Season. Figures also include the baseline footprint of each feature.
- “d” series (Figures 4d, 5d, ...) – Bathymetric difference between Surveys 2 and 4 to illustrate magnitude of seafloor elevation changes.



This report presents the results from the fifth survey. Surveys 1 and 2 represent the baseline surveys for Construction Seasons 1 and 2, respectively. Table 3.1 provides a summary of the seafloor disturbances that were interpreted from the respective baseline surveys.

Table 3.2 provides a summary of the seafloor disturbance associated with installation of each turbine. Seafloor disturbance related to installation of the wind turbine components (e.g. foundations, nacelles, blades, etc.) appears to be confined to the area within 175 meters of each turbine. Table 3.2 categorizes features into:

- Temporary Disturbance Feature: Disturbance caused by construction equipment activities that temporarily occurred on site (e.g. jacking-up of a vessel that left the site after a few hours or days)
- Long-term Disturbance Feature: Disturbance (scour) related to a structure being installed at the site until the project is decommissioned. Scour features related to turbine foundations or concrete mattresses are examples of long-term features anticipated to be present until the structure is removed.
- Cable Trench Feature: Inter-array cable trench scar and concrete mattresses created during Construction Season 2.

3.1.1 Wind Turbine Generator 1

Wind Turbine Generator 1 (WTG 1) is located in the northeastern-most section of the study area and is associated with several well-resolved seafloor disturbances. The surficial sediment around WTG 1 is coarse- to medium-grained sand with fine gravel and contains patches of rippled sand and gravel. Figures 3a, 3b, 3c, and Chart 2 present the local bathymetry and interpreted seafloor disturbances that have occurred around WTG 1. Seafloor disturbances that were created during Construction Season 1 and those that were created during Construction Season 2 are differentiated in Figure 3c. All disturbance features extents are outlined from Surveys 1 to 5 (if possible) to aid in discerning if changes in their size or position has occurred (Figure 3c).

3.1.2 Wind Turbine Generator 2

Wind Turbine Generator 2 (WTG 2) is located in the northeastern section of the study area and is associated with several seafloor disturbances. The surficial sediment surrounding WTG 2 is similar to WTG 1 and is composed of mixed coarse- to medium-grained sand with fine gravel and contains alternating patches of rippled sand and gravel in the vicinity. Figures 4a, 4b, 4c, and Chart 2 present the local bathymetry and interpreted seafloor disturbances that have occurred around WTG 2. Seafloor disturbances that were created during Construction Season 1 and those that were created during Construction Season 2 are differentiated in Figure 4c. All disturbance features extents are outlined from Surveys 1 to 5 (if possible) to aid in discerning if changes in their size or position has occurred (Figure 4c).

3.1.3 Wind Turbine Generator 3

Wind Turbine Generator 3 (WTG 3) is located in the central section of the study area, in a slightly deeper channelized area of the seafloor with wave ripples becoming more dominant. The surficial sediment surrounding WTG 3 is predominantly medium-grained sand with a minor component of fine gravel. Figures 5a, 5b, 5c, and Chart 2 display the local bathymetry and the interpreted seafloor disturbances that have occurred around WTG 3. Seafloor disturbances that were created during Construction Season 1 and those that were created during Construction Season 2 are differentiated in Figure 5c. All



disturbance features extents are outlined from Surveys 1 to 5 (if possible) to aid in discerning if changes in their size or position has occurred (Figure 5c).

3.1.4 Wind Turbine Generator 4

Wind Turbine Generator 4 (WTG 4) is located in the southwestern section of the study area. The surficial sediment surround WTG 4 is a coarse sand and contains alternating patches (ridges/furrows) of sand and gravel, with wave ripples of up to 20 centimeters being apparent. Figures 6a, 6b, 6c, and Chart 2 display the local bathymetry and the interpreted seafloor disturbances that have occurred around WTG 4. Seafloor disturbances that were created during Construction Season 1 and those that were created during Construction Season 2 are differentiated in Figure 6c. All disturbance features extents are outlined from Surveys 1 to 5 (if possible) to aid in discerning if changes in their size or position has occurred (Figure 6c).

3.1.5 Wind Turbine Generator 5

Wind Turbine Generator 5 (WTG 5) is located in the southwestern-most section of the study area. The surficial sediment surrounding WTG 5 is predominantly medium to coarse sand. Figures 7a, 7b, 7c, and Chart 2 display the local bathymetry and the interpreted seafloor disturbances that have occurred around WTG 5. Seafloor disturbances that were created during Construction Season 1 and those that were created during Construction Season 2 are differentiated in Figure 7c. All disturbance features extents are outlined from Surveys 1 to 5 (if possible) to aid in discerning if changes in their size or position has occurred (Figure 7c).

3.2 Seafloor Disturbance Recovery

The rate of recovery from the initial disturbance back to a natural seafloor is dependent on a variety of factors. Some of the main influences on seafloor recovery are bottom current speeds, surficial sediment type, and the influence of large storm events (which can drastically alter the normal flow conditions at a site). Seafloor features identified in the May 11 and 12, 2016 bathymetric survey, in the October 2 through 5, 2016 survey represent baseline conditions from Construction Season 1 (2015) and Construction Season 2 (2016), respectively.

The fifth survey data were compared to the first, second, third, and fourth survey data to evaluate what changes (e.g. recovery), if any, had occurred to seafloor disturbance features created during the two construction seasons. Figures 3c, 4c, 5c, 6c, and 7c symbolize the features based on the construction season they were created. Also, the baseline footprints are shown as light gray (Construction Season 1) and dark gray (Construction Season 2) outlines on the Survey 5 renderings in Figures 3c, 4c, 5c, 6c, and 7c to compare how those features changed between surveys. Figure 8 displays a time series from Survey 1 (May 2016) to Survey 5 (September 2018) for each WTG location to depict seafloor changes observed during the surveys. Each WTG location is discussed in further detail below in Section 3.2 of this report.

Construction Season 1 and 2 baseline surveys identified 139 and 101 disturbance features (160 and 103 if scour features are included), respectively (Charts 5 and 6). Scour features created by the installed structures are not included because they are likely to remain present as long as the structure is present. Survey 5 data indicate that 90 and 87 of Construction Seasons 1 and 2 features, respectively have completely healed. Observations of Survey 5 data suggest all construction disturbance features appear

Table 3.1: Summary of Seafloor Recovery

Interpreted Features	Construction Season Baseline Disturbance						Construction Season 1 (2015) Disturbances									Construction Season 2 (2016) Disturbances									2015 and 2016 Disturbances Recovery				
	Construction Season 1 (2015) Features		Construction Season 2 (2016) Features		Construction Seasons 1 and 2 Total		Recovery Since Baseline at Time of Survey 2 (Oct. 2016)			Recovery Since Baseline at Time of Survey 3 (May 2017)			Recovery Since Baseline at Time of Survey 4 (Oct. 2017)			Recovery Since Baseline at Time of Survey 5 (Sep. 2018)			Recovery Since Baseline at Time of Survey 3 (May 2017)			Recovery Since Baseline at Time of Survey 4 (Oct. 2017)					Recovery Since Baseline at Time of Survey 5 (Sep. 2018)		
	Number of Features	Area (m ²)	Number of Features	Area (m ²)	Number of Features	Area (m ²)	Partially Healed Features	Healed Features	Healed Area (m ²)	Partially Healed Features	Healed Features	Healed Area (m ²)	Partially Healed Features	Healed Features	Healed Area (m ²)	Partially Healed Features	Healed Features	Healed Area (m ²)	Partially Healed Features	Healed Features	Healed Area (m ²)	Partially Healed Features	Healed Features	Healed Area (m ²)			Partially Healed Features	Healed Features	Healed Area (m ²)
Spud	26	1,102	37	4,152	63	5,254	19	0	0 (0%)	8	18	663 (60%)	3	20	710 (64%)	4	20	710 (64%)	25	12	830 (20%)	12	17	1,790 (43%)	11	26	2,269 (55%)	2,979	57%
Circular Depressions	69	2,803	51	1,595	120	4,398	0	3	58 (2%)	31	38	1,454 (52%)	12	44	1,634 (58%)	21	48	1,752 (63%)	8	43	1,298 (81%)	7	46	1,388 (87%)	5	47	1,407 (88%)	3,159	72%
Drag Marks	44	6,414	13	1,129	57	7,543	1	12	1,300 (20%)	25	19	2,077 (32%)	10	20	2,540 (40%)	22	22	2,660 (41%)	1	12	1,061 (94%)	0	13	1,129 (100%)	0	13	1,129 (100%)	3,789	50%
Total*	139 ^b	10,319	101 ^b	6,876	240	17,195	20	15	1,358 (13%)	64	75	4,194 (41%)	25	84	4,884 (47%)	47	90	5,122 (50%)	34	67	3,189 (46%)	19	76	4,307 (63%)	16	86	4,805 (70%)	9,927	58%

Notes:

^a Features were classified as partially healed if the disturbance feature had lessened in size or depth but still remained discernible. A feature was classified as completely healed if the feature was no longer discernible in the bathymetric data.

^b Twenty-one scour features were identified from the Construction Season 1 disturbances which results in a total of 160 disturbance features from Season 1. Two new scour features were identified from Construction Season 2 disturbances which results in a total of 103 disturbance features from Season 2. Scour features formed as a result of installing wind turbine foundations or concrete mattresses. The scour features are not included in the recovery statistics since they are likely to be present as long as the structures (e.g. foundations and concrete mattresses) are present.

^c Inter-array and export cable trench scars and recovery are not included in this table. Refer to Section 3.2.7 and Table 3.3 for assessment of cable trenching disturbance and recovery.

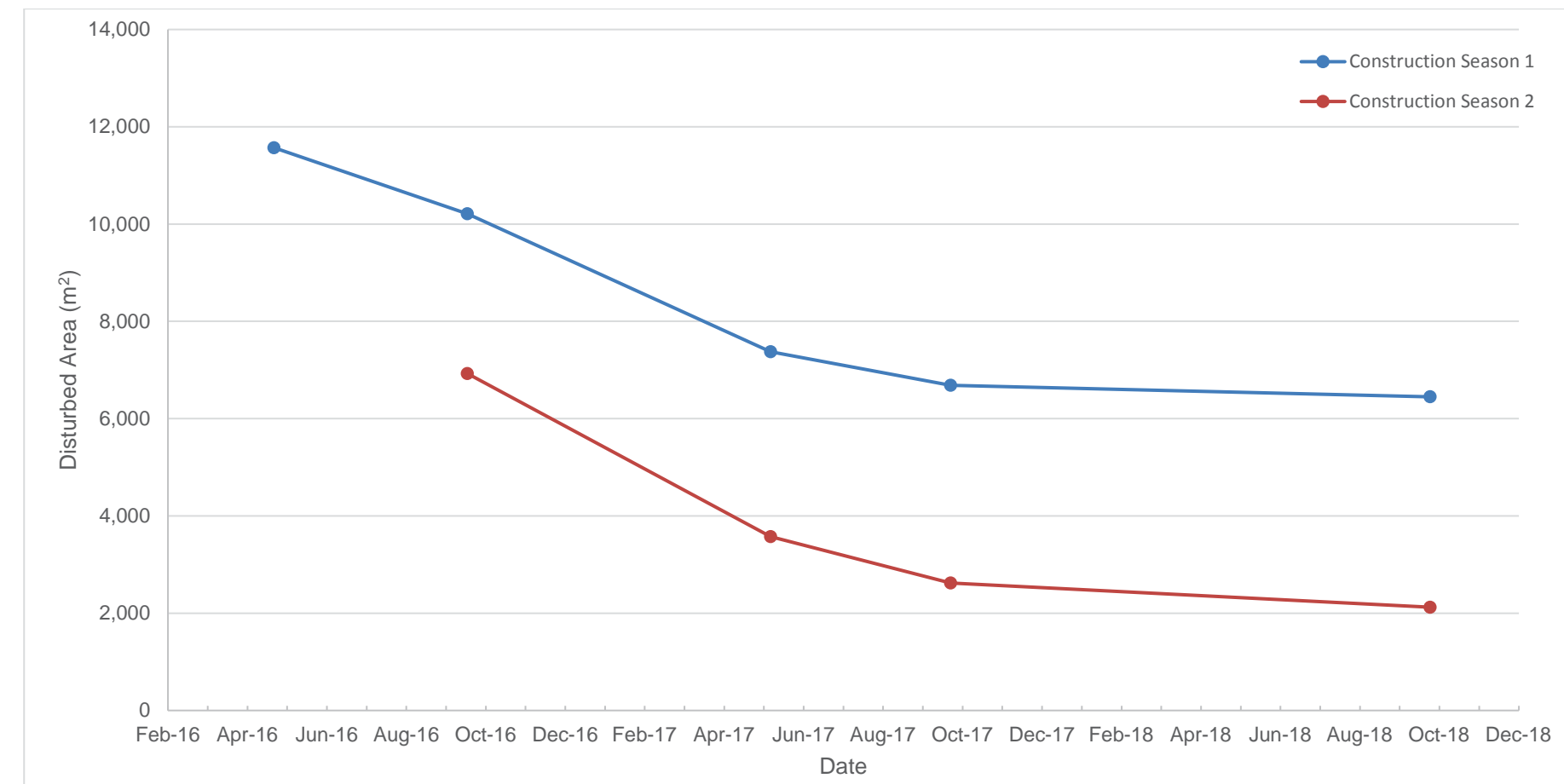

Inset graph (left) presents a summary of the disturbed seafloor area interpreted from each survey.



Table 3.2: Area of Disturbance within 175 meters of Each Turbine

Turbine	CS1 Temporary Features ^a	CS2 Temporary Features ^a	CS1 and CS2 Temporary Features ^a	Long-Term Features (Foundations) ^a	Long-Term Features (Concrete Mats on Cables) ^a	Cable Trench Features ^a	All Features Combined Season 1 and 2 ^a
WTG 1	838 m ² 0.9%	2,261 m ² 2.4%	3,099 m ² 3.2%	308 m ² 0.3%	1,074 m ² 1.1%	1,266 m ² 1.3%	5,747 m ² 6.0%
WTG 2	180 m ² 0.2%	1,001 m ² 1.0%	1,181 m ² 1.2%	268 m ² 0.3%	840 m ² 0.9%	1,566 m ² 1.6%	3,855 m ² 4.0%
WTG 3	100 m ² 0.1%	1,003 m ² 1.0%	1,103 m ² 1.1%	264 m ² 0.3%	840 m ² 0.9%	1,692 m ² 1.8%	3,899 m ² 4.1%
WTG 4	1,100 m ² 1.1%	1,201 m ² 1.2%	2,301 m ² 2.4%	290 m ² 0.3%	636 m ² 0.7%	1,716 m ² 1.8%	4,943 m ² 5.1%
WTG 5	508 m ² 0.5% ^b	508 m ² 0.5%	1,016 m ² 1.1% ^b	109 m ² 0.1%	426 m ² 0.4%	1,038 m ² 1.1% ^c	2,589 m ² 2.7% ^b

Notes;

^a Disturbance is presented in area and percentage of area within 175m of the wind turbine. This is assumed to be the area where installation vessels would be positioned during construction of a wind turbine.

^b Season 1 seafloor disturbance features were not discernable for WTG 5. Seafloor disturbance (e.g. leg penetration) was likely limited due to dense sandy sediments at that location and reworking of sediments likely healed seabed scars by the time the survey was conducted. We have assumed the seafloor disturbance during Season 1 to be equal to Season 2 for estimating purposes. This is likely a conservative assumption.

^c WTG 5 has only one cable connection whereas the other turbine locations have two.

^d Footprint of foundation piles are included in disturbance area

to be undergoing either infilling and/or decrease in size albeit at varying rates. Figures 3c, 4c, 5c, 6c, and 7c and Chart 8 present the baseline footprints of the disturbance features (Construction Season 1 outlined in light gray and Construction Season 2 outlined in dark gray) and their extents as observed in Survey 3 (outlined in black), Survey 4 (outlined in red), and Survey 5 (outlined in orange).

Table C-1 (Appendix C) lists the features that were originally catalogued from Survey 1 and 2 and the observed relative changes (e.g. some change, mostly healed, etc.) that were interpreted to have occurred between May 2017 and September 2018. Table 3.1 presents a summary of the observed recovery from Construction Season 1 and 2 disturbances

3.2.1 Wind Turbine Generator 1

Construction Season 1 Features: Thirteen of the 21 Construction Season 1 features (F77, F95, F98-101, and F103-109) appear to have completely healed and are not discernable in the September 2018 (Survey 5) survey data (Figure 3c and Table C-1). Seven seafloor disturbance features (F82, F92, F96, and F122-125) seem to have diminished in depth associated with sediment infilling (up to 4 centimeters) though F96 appears to be conjoining F160 from Season 2 or F160 may appear larger than previously defined. The remaining feature, F97, of the 21 seafloor disturbances features created during Construction Season 1 displayed no significant change except for areal coverage in the Survey 5 (September 2018) bathymetric data.

Construction Season 2 Features: Forty of the 48 Construction Season 2 features (F198-200, F202-208, F218-220, F222-235, F238-243, F254-256, and F260-261) appear to have completely healed and are no longer discernable in the September 2018 (Survey 5) survey data (Figure 3c and Table C-1). Five seafloor disturbance features (F160-163 and F221) appear to have experienced sediment infilling. The most prominent of these features which remain visible, are the four spud depressions associated with the L/B *Brave Tern* (F160-163). Although the area of these features has approximately remained the same (approximately 150 square meters), they have all undergone infilling ranging from 0.1 to 0.2 meters (Figures 3b and 3c, Figure 9a, and Table C-1). Figure 9a presents profiles through the large spud depressions and the monitoring surveys reveal that they have been progressively infilling at rates of approximately 3 to 10cm per year. Three (F201, F217, and F236) of the 48 seafloor disturbance features created during Construction Season 2 do not appear to have undergone any significant change in the Survey 5 (September 2018) bathymetric data.

Post-Construction Features: Small erosional (scour) features (F263 through F268) have formed adjacent to the concrete mattresses placed on the inter-array cable near the turbines (Figure 3c). The extent of scour remains unchanged between Surveys 4 and 5.

Figure 9b presents profiles across various segments of the mattresses. The scour features extend approximately 1 to 3 meters from the mattresses and are approximately 10 to 25 cm deep. The scour is more prominent on the northern side of the concrete mattresses oriented perpendicular to the principle tidal current flow direction. The principle tidal flow axis is aligned in the NNW-SSE direction. Cable segment in Profile B is nearly aligned with the principle tidal axis and shows the least amount of scour. Cable segments shown in Profiles A, C, and D are oriented perpendicular to the principle tidal axis. Scour is most prevalent on the northern side of the cable/concrete mattresses which indicates the dominant tidal current flow at this location is likely to the NNW (flood tidal current direction).

Scour around the turbine legs appears to be very small to negligible based on the multibeam data. Small depressions up to approximately 5 to 20cm deep have been interpreted in previous monitoring surveys. In Survey 5, scour appears to be less than approximately 10cm at the legs.

3.2.2 Wind Turbine Generator 2

Construction Season 1 Features: Five of the 10 Construction Season 1 features (F102, F112 and F114-F116) appear to have completely healed and are no longer discernable in the September 2018 (Survey 5) survey data (Figure 4c and Table C-1). The remaining five features (F110-F111, F113, and F126-F127) associated with Construction Season 1 experienced little to no change.

Construction Season 2 Features: Twelve of the 16 Construction Season 2 features (F165, F185-190, F209-212, and F214) appear to have completely healed and are no longer discernable in the September 2018 (Survey 5) survey data (Figure 4c and Table C-1). Four seafloor disturbance features (F164, F166-167 and F213) seem to have experienced some degree of change associated with sediment infilling. The most notable of these features which underwent change between Surveys 4 and 5 are the spud depressions associated with the L/B *Brave Tern* (F164, F166-167). Figure 10a presents seafloor elevation profiles through the L/B *Brave Tern* spud depressions. The spud depressions appear to have infilled by 5 to 10cm since Survey 4. When they spud depression were first surveyed (Survey 2) they



were between 40cm and 80cm deep and at the time of Survey 5 they had infilled between approximately 50 to 80 percent complete.

Post-Construction Features: Small erosional (scour) features (F261 through F274) have formed adjacent to the concrete mattresses placed on the inter-array cable near the turbine (Figure 4c). The extent of scour remains largely unchanged between Surveys 4 and 5.

Figure 10b presents profiles across various segments of the mattresses. The scour features extend approximately 1 to 2 meters from the mattresses and are approximately 5 to 20 cm deep. Scour is more prominent on the northern side of the concrete mattresses oriented perpendicular to the principle tidal current flow direction. The principle tidal flow axis is aligned in the NNW-SSE direction. Cable segment in Profile B is nearly aligned with the principle tidal axis and shows the least amount of scour. Cable segments shown in Profiles A and C are oriented perpendicular to the principle tidal axis. Scour is most prevalent on the northern side of the cable/concrete mattresses which indicates the dominant tidal current flow at this location is likely to the NNW (flood tidal current direction).

Scour around the turbine legs appears to be very small based on the multibeam data. Small depressions up to approximately 5 to 20cm deep have been interpreted in previous monitoring surveys. In Survey 5, scour appears to be less than approximately 10 to 15cm at the legs.

3.2.3 Wind Turbine Generator 3

Construction Season 1 Features: Four of the 8 Construction Season 1 features (F80, F93, and F141-142) are completely healed and are not discernable in the September 2018 (Survey 5) survey data (Figure 5c and Table C-1). F128 appears to have undergone some change related to infilling in Survey 5. The remaining three disturbance features (F89, F94, and F129) which remained visible in the September 2018 survey data (Survey 5) displayed no significant change.

Construction Season 2 Features: The four spud depressions (Features F168-171) that were identified from the Construction Season 2 baseline survey (Survey 2—Oct. 2016) and associated with the L/B *Brave Tern* all appear to be completely healed in the September 2018 (Survey 5) survey data (Figures 5b, 5c, Figure 11, and Table C-1). Survey 2, the first survey that recorded the depressions, indicated they were between 70 and 110cm deep at one point. They infilled significantly (80 to 85%) between Surveys 2 and 3 (Figures 8 and 11).

Post-Construction Features: Little to no erosional (scour) features have formed adjacent to the concrete mattresses placed on the inter-array cable near the turbine. Scour around the turbine legs appears to be very small based on the multibeam data. Small depressions up to approximately 5 to 25cm deep have been interpreted in previous monitoring surveys. In Survey 5, scour appears to be less than approximately 10 to 15cm at the legs. As part of the RODEO program, scour monitors were installed on the northeast and southeast corner legs (Fugro, 2018). The scour monitors continuously recorded seabed elevation changes for a period of 14 months during 2016 and 2017 (Fugro, 2018). The scour monitors recorded seabed level changes of up to approximately:

- 0.2m over tidal cycles and
- 0.6m over one month periods.



3.2.4 Wind Turbine Generator 4

Construction Season 1 Features: Five of the nine Construction Season 1 features (F78, F117-119, and F121) appear to have completely healed and are not discernable in the September 2018 (Survey 5) survey data (Figures 6b, 6c and Table C-1). Seafloor disturbance features F130-F131 associated with Construction Season 1 experienced some change related to sediment infilling and seafloor disturbance features F81 and F120 experienced little to no change.

Construction Season 2 Features: Eight of the 10 Construction Season 2 features (F174-175 and F246-251) appear to have completely healed and are not discernable in the September 2018 (Survey 5) survey data (Figure 6c and Table C-1). The remaining two features (F172-173) are two of the four spud depressions attributed to the L/B *Brave Tern* (F172-175) (Figures 6b and 12). Two of these spud depressions (F174 and 175) have completely healed, while the two northeastern spud depressions (F172-173) appear to have experienced very little infilling since Survey 4 (Figure 6b and Figure 12). The differing infill rates of the L/B *Brave Tern* leg depressions is remarkable. The two southwestern leg depressions that have completely healed are located in a ripple field that is actively changed between surveys. The ripples changed in orientation and extent and indicates higher rates of sediment reworking than where the two northeastern depressions are located. The spud can depressions were observed to be up approximately 60cm deep during Survey 2. The northeastern spud depressions are approximately 40 to 50 percent infilled at the time of Survey 5 (Figure 12).

Post-Construction Features: No apparent erosion features were observed around the concrete mattresses.

Scour at the legs is notably less than at WTG-1 and WTG-2. Scour interpreted from the monitoring surveys were observed to be up to approximately 4 to 10cm around the legs.

3.2.5 Wind Turbine Generator 5

Construction Season 1 Features: All of the disturbances (F132–135) that existed in this area prior to the May 2016 survey displayed some slight change related to sediment infilling in the September 2018 bathymetry data (Table C-1).

Construction Season 2 Features: All four of the seafloor disturbance features (F176-F179) that were identified in the Construction Season 2 baseline survey (Survey 2—Oct. 2016) appear to have completely healed and are not discernable in the September 2018 (Survey 5) survey data (Figures 7b, 7c, and Table C-1).

Post-Construction Features: No apparent erosion features were observed around the concrete mattresses.

Scour at the legs is notably less than at WTG-1 and WTG-2. Scour interpreted from the monitoring surveys were observed to be up to approximately 4 to 9cm around the legs.

3.2.6 Recovery from Seafloor Disturbance Elsewhere in the Work Area

Construction Season 1 Features: Based on our review of the Survey 5 data, approximately 44 percent of the Construction Season 1 disturbances appear to be completely healed (Table 3-1). Approximately



18 percent of the seafloor disturbances located outside the immediate vicinity of the WTG's did not appear to have undergone significant change since Survey 4 (October 2017); all other features have completely healed or appear to have undergone some recovery since Survey 4.

Construction Season 2 Features: Based on our review of the Survey 5 data, approximately 69 percent of the Construction Season 2 disturbances appear to be completely healed (Table 3-1). Approximately 4 percent of the seafloor disturbances located outside the immediate vicinity of the WTG's did not appear to have undergone significant change from the Survey 4 (October 2017); all other features have completely healed or appear to have undergone some recovery since Survey 4.

3.2.7 Cable Trench Monitoring

Inter-array cables are located within the designated survey area and were surveyed during each monitoring survey. However, the export cable and transmission cable between Block Island and the mainland were outside the designated monitoring survey area but portions were surveyed as time allowed as described in Section 1.4.1. This section describes the surveys and our observations of the recovery rates of the cable trenches. To assess the recovery of the cable trench after installation, sections of the cable trench scar were measured and designated as recovered or still present. The trench scar was considered to be recovered if trench features were not discernable in the bathymetric data and the seafloor appeared to be restored to its natural topography. The following information and data renderings were created to aid the interpretation:

- Sun-illuminated hill-shaded relief to create a 3D-like rendering of the seafloor and enhance the trench scar features and overspill levees,
- Bathymetric contours at 0.1m intervals, and
- Cross sections at various locations across the trench along the routes.

Chart 7 and Figure 13 present comparisons of pre-lay and post-lay surveys. The following surveys were used to evaluate trench recovery rates. Table 3.3 provides a summary of recovery monitoring assessment.

- Inter-array Cable Routes: All segments were surveyed as part of the Surveys, 1, 2, 3, 4, and 5.
- Export Cable Route from Wind Farm to Block Island:
 - Pre-lay Survey during May 2016 covered approximately 87 percent of route
 - Post-lay Survey during October 2016 covered approximately 95 percent of route
- Block Island Transmission Cable from Block Island to Rhode Island Mainland:
 - Pre-lay covered 61 percent of the route
 - Post-lay during cable installation in July 2016 surveyed approximately 50 percent of route (mainland to mid-way point between Block Island and mainland)
 - Post-lay Survey during October 2016 surveyed approximately 90 percent of the route.



Table 3.3: Summary of Cable Trench Recovery

	Survey Date	Post-lay Survey Length (km)	Trench Length Recovered (Percentage)
Inter-array Cable	Survey 1 (May 2016)	Pre-lay (no cable installed)	
	Survey 2 (Oct 2016)	4.6	0.8 (17%)
	Survey 3 (May 2017)	4.6	1.6 (35%)
	Survey 4 (Oct 2017)	4.6	1.8 (39%)
	Survey 5 (Sep 2018)	4.6	1.9 (41%)
Export Cable (Wind Farm to Block Island)	Survey 1 (May 2016)	Pre-lay (no cable installed)	
	Survey 2 (Oct 2016)	9.1	5.6 (62%)
Block Island Transmission Cable to Mainland	Survey 1 (May 2016)	Pre-lay (no cable installed)	
	July 2016 Survey	19.4	0.5 (3%)
	Survey 2 (Oct 2016)	31.2	3.7 (12%)
Total		44.9	11.2 (25%)

3.2.8 Seafloor Recovery Rates

Seafloor recovery rates are anticipated to vary across the scale of a wind farm. Recovery primarily occurs as bottom currents (1) transport sediments that infill the disturbance features or (2) cause bedforms to organize and shift or migrate. Sediment transport of sediments by bottom currents or shifting/migration of bedforms is dependent upon bottom current speeds, flow direction and duration, and seafloor sediment type. Variation in those parameters will cause sediment mobility, and ultimately the seafloor recovery rates to vary.

The bathymetric data reveal bedforms of varying type, size, and orientation. Bedform type (e.g. ripple or dune) and size are dependent on the bottom current speed, flow direction(s), and sediment type. Stow et al. (2009) and Ashley (1990) have developed interrelationships between sediment type, current speeds, and bedforms. Furthermore, Van Rijn (1993) and Allen (1982) present relationships between bedforms, mobility, and sedimentary environments.

Through comparison of the surveys, we identify areas where bedforms have changed. By delineating areas with common bedforms and monitoring the changes in bedforms using the surveys, we will develop an understanding of how sediment mobility and the seafloor recovery will vary across this site. The periodic bathymetric surveys are being used to refine this understanding and final report will be prepared that summarizes our assessment of seafloor recovery rates at this site. The following section describes our interim evaluation of sediment mobility in the study area.

3.2.8.1 Observed Changes in Bedforms

The survey data reveal bedforms of varying size (both dune and ripple scale) and orientation. Observations from Surveys 1 through 5 indicate that the orientations and locations of individual bedforms and the extents of ripple and dune fields have changed between surveys. Areas where the



bedforms appear to have changed more notably have been associated with areas where seafloor disturbances have undergone a higher sediment infill rate and thus appear to be healing more quickly.

In the region around WTG 2 and between WTG 3 and 4 (Figure 14), dune-scale bedforms (0.5 to 1.5m tall) shifted to the northwest by the following magnitudes:

- 2.5 to 6 meters between Surveys 1 (May 2016) and 3 (May 2017).
- Approximately 3 meters between Survey 3 (May 2017) and Survey 4 (October 2017).
- Approximately 2 meters between Survey 4 (October 2017) and Survey 5 (September 2018).
- Approximately 11 meters in total between Survey 1 and 5 (Figure 14).

Several large ripple fields were observed to either change in spatial extent or size and in orientation between some surveys (Figure 15). Orientation of ripple crestlines in Surveys 1 and 3 were primarily east-west oriented, while in Survey 2 they were primarily northeast-southwest oriented. Observations of ripple crestlines in Survey 4 revealed that their orientation had approximately remained the same (east-west). It was also noted that the ripples in Survey 4 had grown in spatial extent and in height as compared to previous surveys. Ripples observed in Survey 4 were up to 20 cm tall, compared to approximately 10 cm tall in Surveys 1 and 3 and only about 5 cm tall in Survey 2. Although a seasonal change could still be at work, which was postulated in Survey Report 3, the lack of change in orientation and growth of spatial extent and size of the ripples observed in Survey 4 could be due to the occurrence of large storm events that were present in the area shortly before the Survey 4 data was acquired (e.g. Hurricane Jose at the end of September 2017). Ripple crestlines retain an east-west orientation in Survey 5 except for in the area around WTG 1 where the orientation is northeast-southwest and the area around WTG 4 where there appears to be a combination of the two orientations present. Ripples in Survey 5 had reduced in height to approximately 10 cm tall since Survey 4 where they were observed to be up to 20cm tall.

3.2.8.2 Seafloor Recovery Rate Zones

We categorize the survey area into zones based on bedform morphology and changes inferred from data collected during Surveys 1 through 5. Our observations of the survey data indicate that bedforms shift at the site at varying rates and extents of bedform zones (e.g. ripple fields) appear to change over time. We have also inferred the sediment type (e.g. grain size) based on information provided in DW project reports, Fugro's MBES backscatter data collected during Survey 5 (Figure 16), and benthic study grab sampling conducted at WTG 1, WTG 3, and WTG 5 by University of Rhode Island and Fugro during the RODEO program. Correlation between the backscatter data with previously acquired Side Scan Sonar data and grain size data from others, allowed interpretive boundaries to be established and updated for this report (based on the September 2018 survey data). Areas which displayed a high intensity on the backscatter indicate a harder return and suggested coarse material. Conversely, areas which experienced a lower intensity, suggested a finer grained material (e.g. fine sand).

We have evaluated recovery rates for the for various zones using the MBES data and interpretation from the Surveys 1 through 5. Recovery rates are variable across the site and related to seabed sediment type and morphology. The contrast between recovery rates can be abrupt over short distances as observed at WTG 4 in Figures 6b and 6c. In Figure 6b, two of the L.B Brave Tern spud depression are completed recovered and two are still present. The horizontal distance between the



spud depressions that completely recovered and the two still present is only approximately 150 meters which suggests the sediment type is a primary factor in sediment reworking and seafloor recovery. The seafloor recovery zones shown in Figure 15 are described in the following section and summarized in Table 3.4.

Table 3.4: Seafloor Recovery per Zone

	Percent of Disturbed Area Completely Healed at Time of Survey 5	Comment
Zone 1 – High Seafloor Recovery Rate	82%	Area of dynamic ripples and predominantly medium- to coarse-grained sand
Zone 2 – Moderate Seafloor Recovery Rate	32%	Area of ripple to dune scale bedforms and predominantly fine-grained sand
Zone 3 – Low Seafloor Recovery Rate	0%	Coarse sand, gravel, and cobbles

Zone 1 – High Seafloor Recovery Rate. This zone is characterized by abundant ripples that appeared to change in size, extent, and orientation between the surveys. Seafloor sediment type is predominantly medium- to coarse-grained sand with low fine-grained sediment (particle size less than 0.075mm) content. Side scan sonar reflectivity is high and MBES backscatter intensity values are typically between -20 and -25 db. Seafloor disturbance recovery rates were approximately 2.5 times higher than in Zone 2 (Table 3.4).

Zone 2 – Moderate Seafloor Recovery Rate. This zone is characterized by sand accumulation areas that appear to be migrating over coarser sediments. The side scan sonar reflectivity is generally low and MBES backscatter intensity values are typically between -27 and -30 db. Sediment type is inferred to be predominantly fine to medium-grained sand with low amount of fine-grained sediment (particle size less than 0.075mm). The sand accumulation bodies are approximately 0.5 to 1m tall and fall within a dune scale size. Figure 14 presents examples of these sand accumulation features and interpreted to be moving at rates of approximately 1 to 3m per year in a northwesterly direction.

Zone 3 – Low Seafloor Recovery Rate. This zone contained the coarsest seafloor sediment and slowest recovery. Seafloor sediment is predominantly sand, gravel, and cobbles. This zone is confined to the southwest portion of the survey area and no turbines or cables were installed in this zone.



4. SUMMARY

The Seafloor Disturbance and Recovery Monitoring Program is using periodic multibeam bathymetric surveys to identify disturbances of the seafloor that resulted from wind farm construction activities. The periodic surveys are also being used to monitor recovery from those disturbances. The monitoring surveys are encompassing the area denoted by DW as the "Work Area." The Work Area is the region where construction vessels were authorized to anchor or set spuds during construction.

The Block Island Wind Farm was constructed during two construction seasons. The jacket foundations were installed during Construction Season 1 which occurred in 2015 and ended in mid-December. Survey 1 was conducted in May 2016 and represents the baseline survey for Construction Season 1 disturbance monitoring. The survey activities and results from that survey were provided in our Survey 1 Report.

During Construction Season 2, which occurred in 2016, towers, nacelles, blades, inter-array cables, and export cables were installed. Also, during 2016, concrete mats were placed on cable sections that were intentionally left unburied near the turbines to allow the cables to be pulled into the turbine. Survey 2 was conducted at the end of Construction Season 2 in October 2016 and represents the baseline survey for Construction Season 2 disturbance monitoring. The survey activities and results from that survey were provided in our Survey 2 Report.

After completion of all construction activities, the following monitoring surveys were conducted. A report was issued after each survey and summarized the seafloor recovery progress. Those surveys included:

- Survey 3 (May of 2017)
- Survey 4 (October 2017)
- Survey 5 (September 2018)

Construction Season 1 (2015) created 139 disturbance features that comprise an area of approximately 10,319 m². Survey 5 (September 2018) revealed that 70 of those features had partially healed and 90 had completely healed. The completely healed features comprise an area of 5,122 m² which indicates approximately 50 percent of the disturbed area has completely healed (Table 3.1).

Construction Season 2 (2016) created 101 disturbance features that comprise an area of approximately 6,876 m². Survey 5 (September 2018) revealed that 17 of those 101 disturbance features had partially healed and 86 had completely healed. The completely healed features comprise an area of 4,805 m² which indicates that approximately 70 percent of the disturbed area has completely healed (Table 3.1).

Seafloor disturbance related to the installation of a wind turbine was assessed for each turbine location. Based on the spatial extent of disturbances, we assumed that installation activity disturbance was confined to within approximately 175 meters of each turbine. Seafloor disturbance and percentage of disturbed area within 175 meters of the turbine were evaluated.

- Temporary features from construction activities (e.g. jacking-up of a vessel) were estimated to disturb between approximately 1,100 m² to 3,100 m² of seafloor area or approximately 1.1 to 3.2 percent of the area within 175 meters of the turbines.

- Cable trench scars were estimated to disturb between approximately 1,040 m² and 1,700 m² or approximately 1.1 to 1.8 percent of the area at each turbine.
- Long-term features related to foundation piles and scour is estimated to impact approximately 110m² to 310m² or approximately 0.1 to 0.3 percent of the area at each turbine.
- Long-term features related to concrete mattresses placed on the cables at the turbine area is estimated to impact approximately 425 m² to 1,075 m² or 0.4 to 1.1 percent of the area at each turbine.
- The total disturbance related to temporary and long-term features, cable trench scars is estimated to be approximately 2,600 m² to 5,700 m² or approximately 2.7 to 6.0 percent of the area around each turbine.

We interpreted seafloor recovery rate zones based on seafloor characteristics and morphology inferred from the MBES, side scan sonar, and sediment grain size data (Figure 15).

- Zone 1 – High Recovery Rate: 82 percent of the seafloor disturbance had completely healed by Survey 5
- Zone 2 – Moderate Recovery Rate: 32 percent of the seafloor disturbance had completely healed by Survey 5
- Zone 3 – Low Recovery Rate: None of the disturbance features had completely healed by Survey 5

Recovery of cable trench scars was also evaluated. The inter-array cable was surveyed during each monitoring survey. Approximately 41 percent of the inter-array cable trench scar appears to have completely healed by September 2018 (Survey 5). The export cable and Block Island transmission cable were surveyed when time allowed. Comparison between pre-lay and post-lay cable surveys revealed that approximately 12 percent of the Block Island transmission cable trench scar had completely healed, and that 62 percent of the export cable trench scar had completely healed by October 2016 (Survey 2). The variance in recovery rates is likely due to a combination of factors, including water depth, grain size, and bottom current speeds.

Introduction of structures can modify near-bottom current flow processes and induce scour. The Block Island Wind Farm installed four-legged jacket foundations and placed concrete mattresses on sections of cable near the turbines that were intentionally left unburied. Sections of the cable near the turbines were left unburied to allow them to be pulled into the turbine. Concrete mattresses were placed on the unburied sections to provide protection to the cables. The monitoring surveys revealed that small erosional features had developed adjacent to east-west oriented mattresses at WTG 1 and WTG 2 (Figures 9b and 10b). The east-west oriented concrete mattresses are nearly perpendicular to the principle tidal axis which is inferred to be NNW-SSW direction. The scour features were notably larger on the northwest side of concrete mattresses. The scour features were up about 5 to 25 cm deep and extended approximately 1 to 3 meters from the mattresses. Sections of cable and mattresses oriented north-south did not appear to exhibit scour. The bias of scour development to the north-northwest suggest the flood tidal current is dominant in the area of WTG 1 and WTG 2. The extent and depth of scour did not appear to change significantly between Surveys 3, 4, and 5. Scour was not observed adjacent to concrete mattresses at WTG 3, WTG 4, and WTG 5.

Scour at the turbine legs was interpreted to be fairly small based on the multibeam surveys. Scour depths of 10 to 25 cm were interpreted at the legs. WTG 1 and WTG 2 exhibited the deepest scour. Multibeam surveys provide an instantaneous snapshot of scour conditions at a location. Scour is a dynamic process that can develop and infill during tidal cycles, discrete storm events, seasonal variations or other types of variations in oceanographic processes. A recently developed scour monitoring system was used to continuously monitor scour and infill variations that were not observed in multibeam surveys. WTG 3 had scour monitors installed for a period of 14 months that were used to continuously monitor seabed elevations. The scour monitors recorded seabed level changes of up to approximately:

- 0.2m over tidal cycles and
- 0.6m over one-month periods (included storm events).

The scour monitors captured storm events, monthly, and seasonal scour development, infill processes and seafloor elevation variations that were not captured by the periodic multibeam surveys. Details of the scour monitoring system evaluation are provided the Scour Monitor and AWAC Recovery Operation Report (Fugro, 2018) The two monitoring programs provide a comparison of methods that can be used to monitor scour and seafloor changes at wind farms.

5. REFERENCES

Allen, J.R. (1982) *Sedimentary Structures: Their Character and Physical Basis*. Elsevier, New York, NY.

Ashley, G.M. (1990), "Classification of Large-Scale Subaqueous Bedforms: A New Look at an Old Problem," *Journal of Sedimentary Petrology*, Vol. 60, pp. 363-396.

Fugro (2016) *Seafloor Disturbance and Recovery Monitoring Program, Survey 1 May 2016*. Fugro Project No. 04.81150001, prepared for HDR. Issued on September 7, 2016.

Fugro (2017a) *Seafloor Disturbance and Recovery Monitoring Program, Survey 2 October 2016*. Fugro Project No. 04.81150001, prepared for HDR. Issued on June 8, 2017.

Fugro (2017b) *Seafloor Disturbance and Recovery Monitoring Program, Survey 3 May 2017*. Fugro Project No. 04.81150001, prepared for HDR. Issued on June 1, 2017.

Fugro (2017c) *Seafloor Disturbance and Recovery Monitoring Program, Survey 4 October 2017*. Fugro Project No. 04.81150001, prepared for HDR. Issued on November 13, 2017.

Fugro (2018) *Block Island Wind Farm, Scour Monitor and AWAC Recovery Operation Report, Block Island Wind Farm, USA*. Fugro Report No. 160215-5, prepared for HDR. Issued on January 29, 2018.

Stow, Dorrik A.V., Hernández-Molina, Javier, Llave, Estefania, Sayago-Gil, Miriam, del Río, Victor Díaz, and Branson, Adam (2009), "Bedform-velocity matrix: The estimation of bottom current velocity from bedform observations," *Geology*, v.37, no. 4, p.327-330.

Van Rijn, L.C. (1993) *Principle of Fluid Flow and Surface Waves in Rivers, Estuaries, Seas, and Ocean*. Aqua, Amsterdam, The Netherlands.

FIGURES

N:\Projects\04_2015\04_8115_0001_BOEM_RODEO\BlockIsland_R10\Outputs\Post_Con_Survey_5\IMXD\Fig-1_Study_Area.mxd, 1/11/2019, T.Weathers

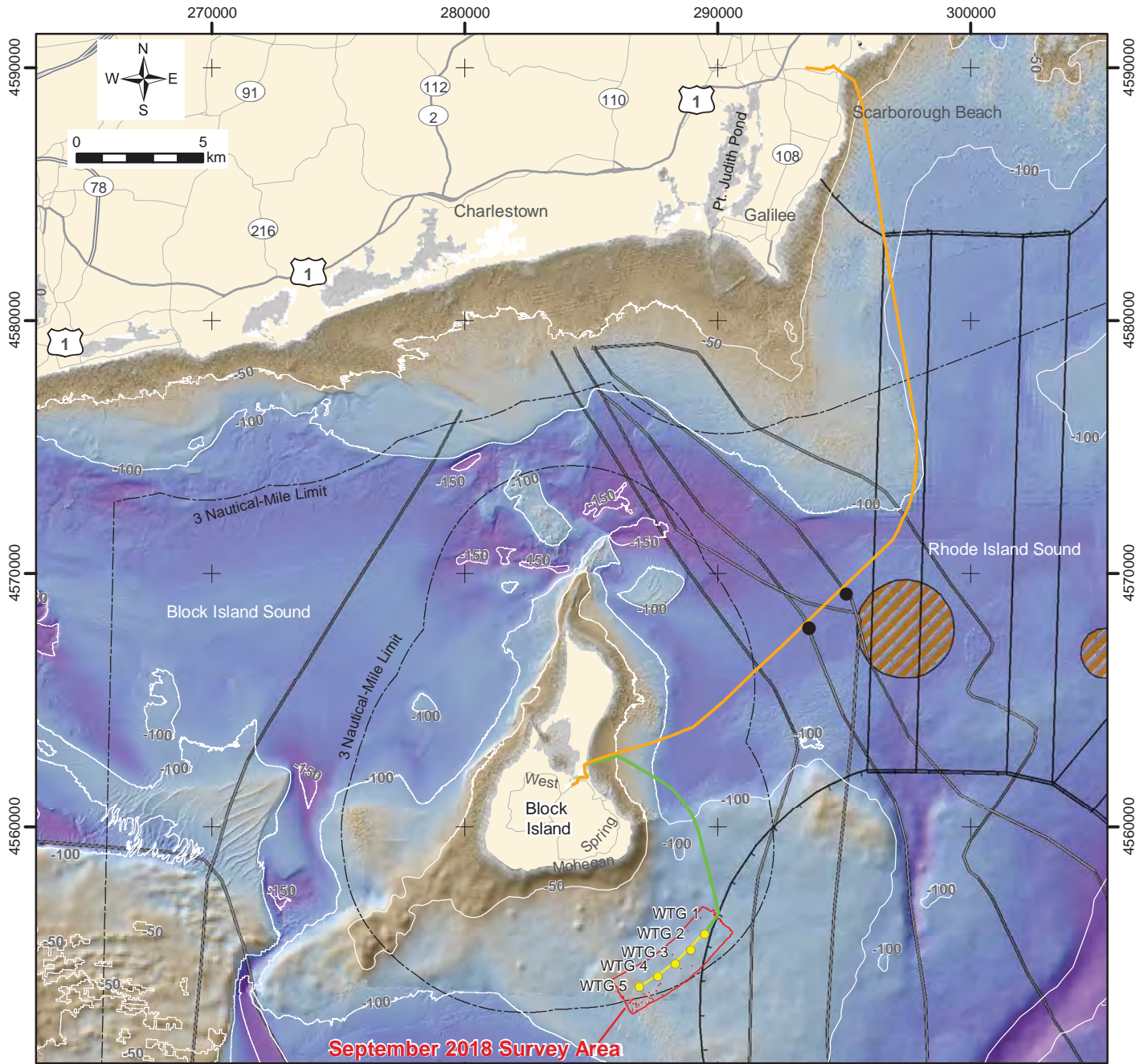

Legend

Block Island Wind Farm

- Turbine
- Active Cable Crossing
- BITS Alternative 1
- Export Cable
- Inter Array Cable

Bathymetry (MLLW, ft)

Source: compiled NOAA survey data

- Contour interval is 50 ft.
- High : 0
- Low : -220

Base Map

- Submarine Cable
 - 3 Nautical Mile State Limit
 - Precautionary Area
 - Traffic Separation Scheme Lane
 - Dumping Ground Area
 - +
- Coordinate Grid: UTM Zone 19N, NAD83, Meters

STUDY AREA
Seafloor Monitoring Study
Block Island Wind Farm and Transmission Project
Offshore Rhode Island

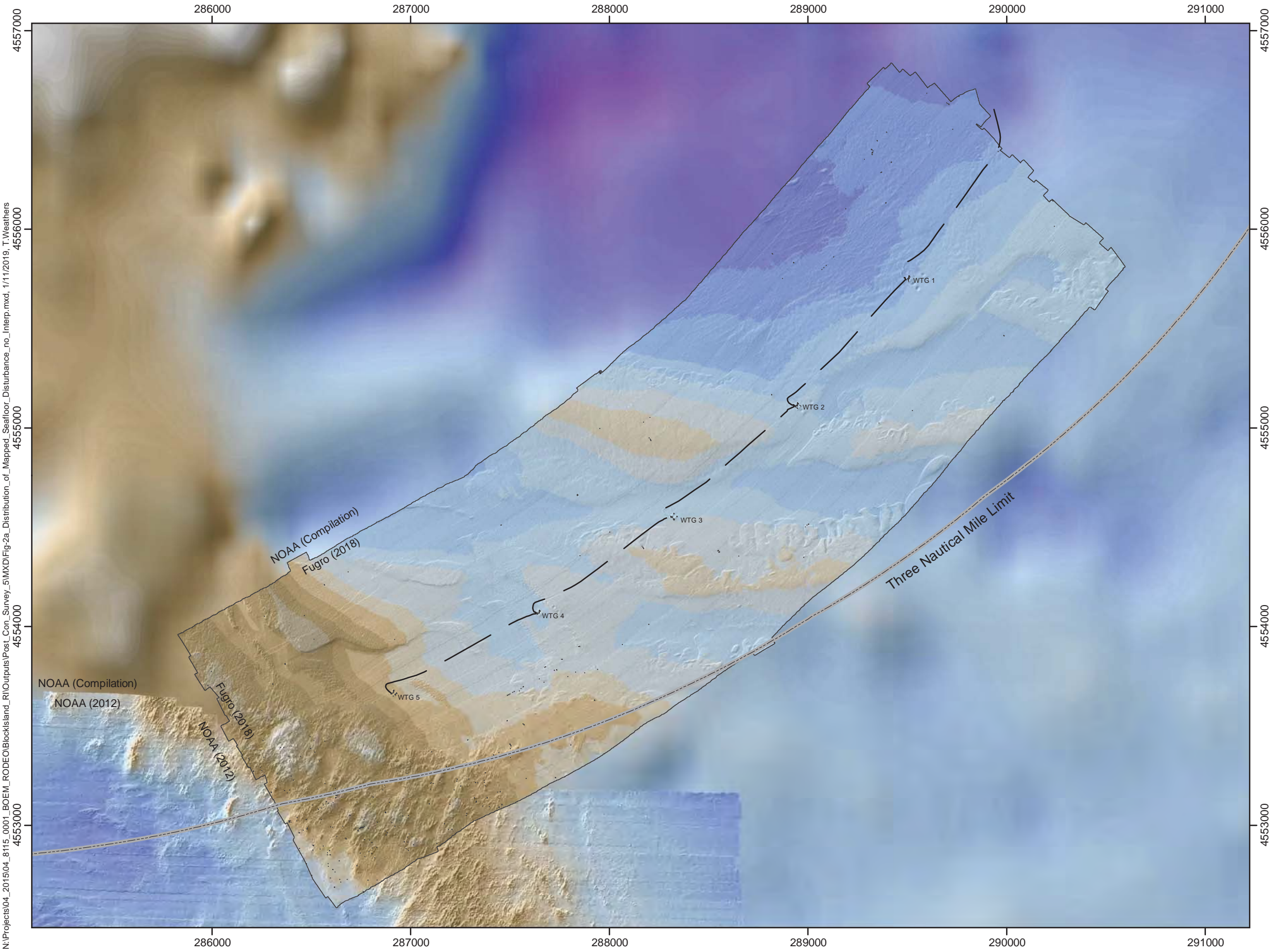

Legend

- Export Cable/Inter Array Cable
- - - Three Nautical Mile State Limit

Bathymetry (Meter, MLLW)

Lower than -33	-26 to -25
-33 to -32	-25 to -24
-32 to -31	-24 to -23
-31 to -30	-23 to -22
-30 to -29	-22 to -21
-29 to -28	-21 to -20
-28 to -27	-20 to -19
-27 to -26	-19 to -18

Notes:

1. Fugro 2018 multibeam bathymetry was collected on September 29 and 30, 2018.
2. NOAA (2012) multibeam bathymetric data is from the National Oceanic and Atmospheric Administration's (NOAA) hydrographic survey of Block Island Sound, New York. This survey was conducted August 25 through August 29, 2012.
3. Bathymetric data is a compilation of NOAA sounding files in the area that were collected between 1938 to 1979.



Coordinate System: UTM 19N, NAD83, Meter

FUGRO September 2018 BATHYMETRY
Seafloor Monitoring Study
Block Island Wind Farm and Transmission Project
Offshore Rhode Island

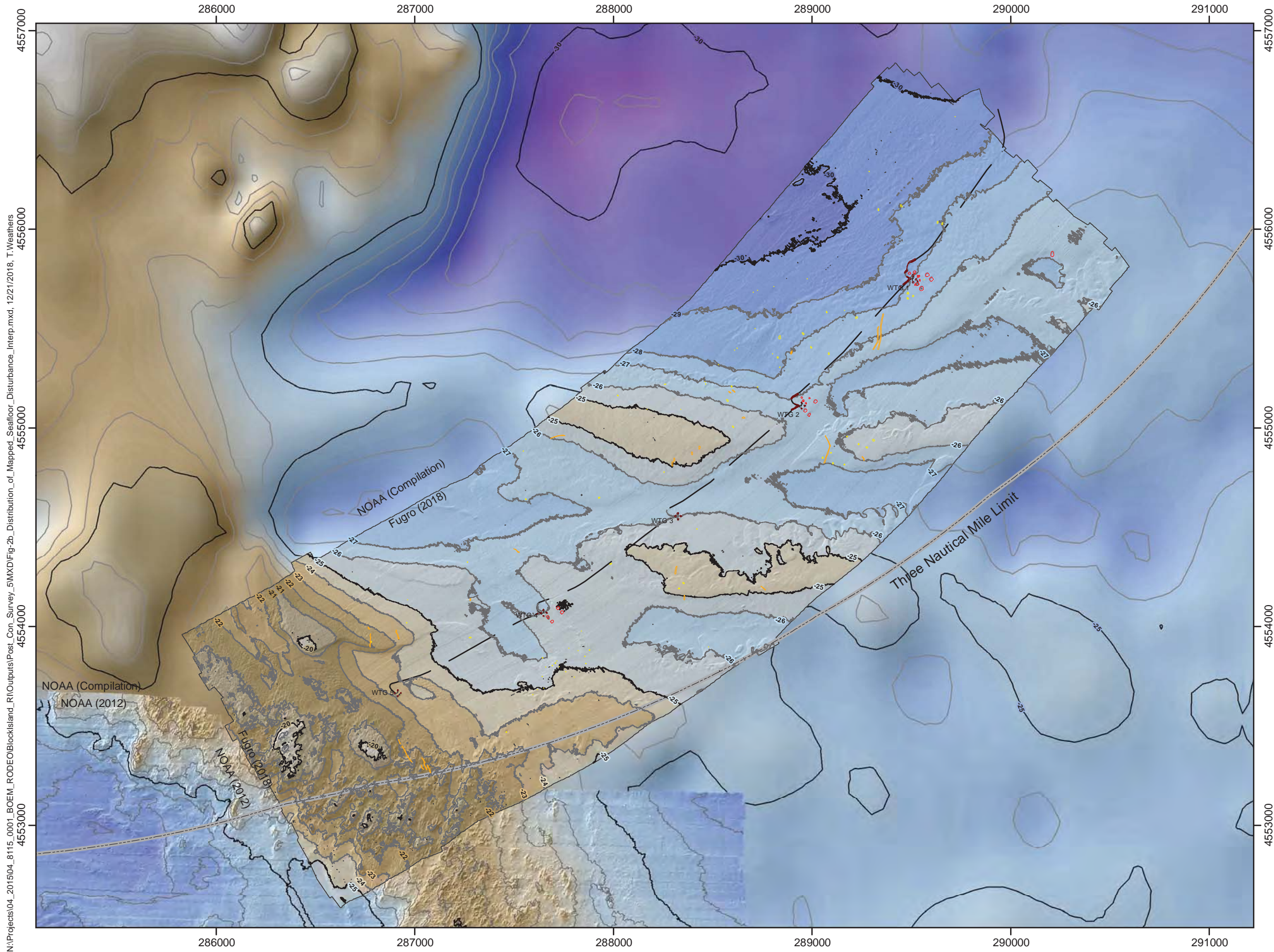

Legend

- Export Cable/Inter Array Cable
- Three Nautical Mile State Limit

Bathymetry (Meter, MLLW)

Lower than -33	-26 to -25
-33 to -32	-25 to -24
-32 to -31	-24 to -23
-31 to -30	-23 to -22
-30 to -29	-22 to -21
-29 to -28	-21 to -20
-28 to -27	-20 to -19
-27 to -26	-19 to -18

- Contour interval is 5 meters.
- Contour interval is 1 meter.

Interpreted Seafloor Disturbance Features

- Spud Location
- Scour
- Linear Feature (Possible Drag Mark)
- Circular Depression

Notes:

1. Fugro 2018 multibeam bathymetry was collected on September 29 and 30, 2018.
2. NOAA (2012) multibeam bathymetric data is from the National Oceanic and Atmospheric Administration's (NOAA) hydrographic survey of Block Island Sound, New York. This survey was conducted August 25 through August 29, 2012.
3. Bathymetric data is a compilation of NOAA sounding files in the area that were collected between 1938 to 1979.



Coordinate System: UTM 19N, NAD83, Meter

INTERPRETED SEAFLOOR DISTURBANCE FEATURES
Seafloor Monitoring Study
Block Island Wind Farm and Transmission Project
Offshore Rhode Island

N:\Projects\04_2015\04_8115_0001_BOEM_RODEOBlockIsland_R1\Outputs\Post_Con_Survey_5\WXDI\Fig-2b_Distribution_of_Mapped_Seafloor_Disturbance_Interp.mxd, 12/21/2018, T:\Weathers

N:\Projects\04_2015\04_8115_0001_BOEM_RODEO\BlockIsland_RI\Outputs\Post_Con_Survey_5\IMXD\Fig-3a_WTG1_Bathymetry_with_Contours.mxd, 1/1/2019, T.Weathers

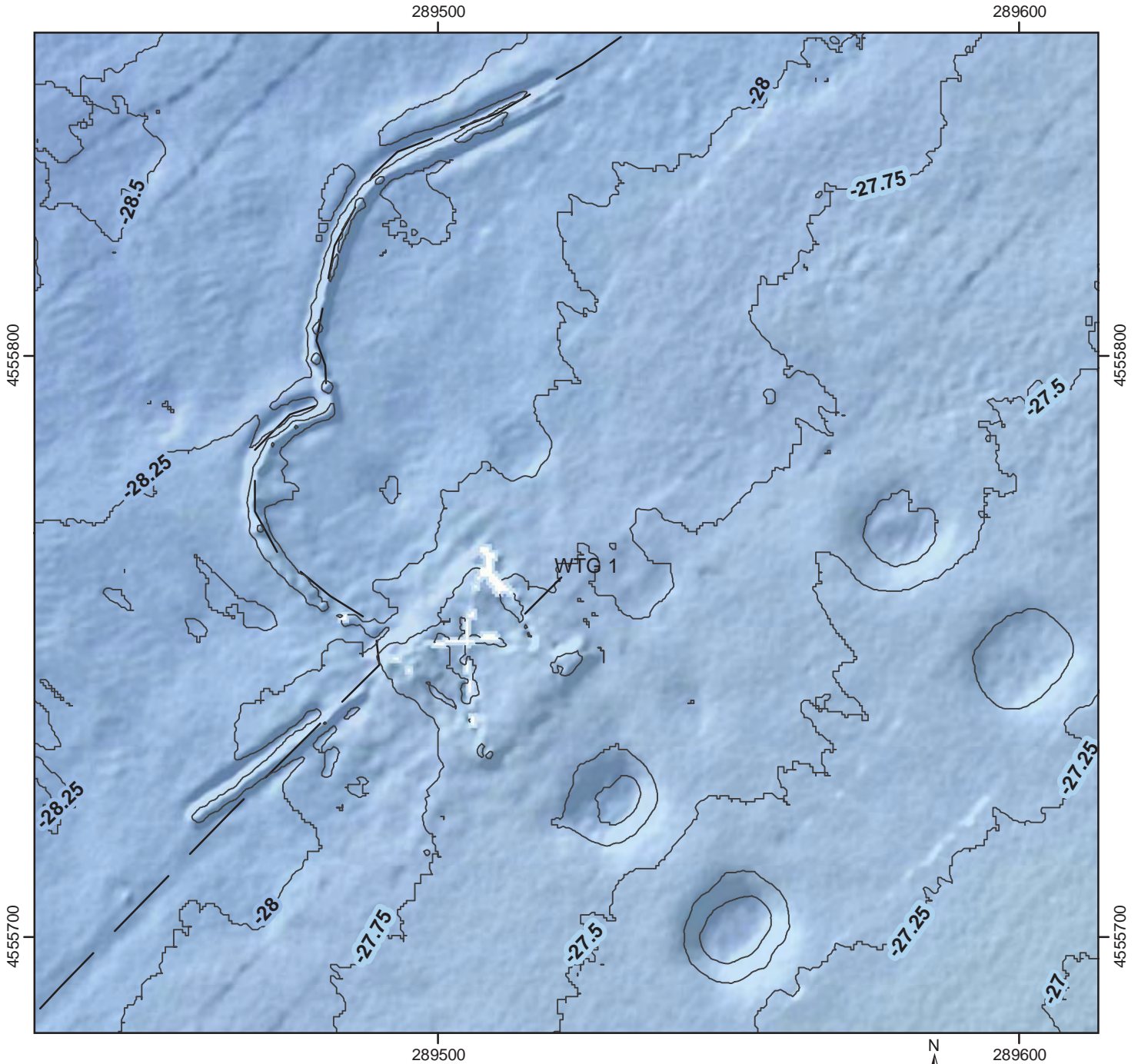

Legend

— Export Cable/Inter Array Cable

**September 2018 Fugro Bathymetry
(Meter, MLLW)**

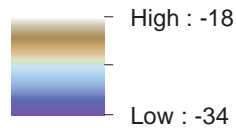

High : -18

Low : -34

— Contour interval is 0.25 meters



Coordinate System: UTM 19N, NAD83, Meter

BATHYMETRY
WIND TURBINE GENERATOR NO. 1
 Seafloor Monitoring Study
 Block Island Wind Farm and Transmission Project
 Offshore Rhode Island

N:\Projects\04_2015\04_8115_0001_BOEM_RODEO\BlockIsland_RI\Outputs\Post_Con_Survey_5MXDI\Fig-3b_WTG1_Bathymetry_with_Interp.mxd, 1/11/2019, T.Weathers

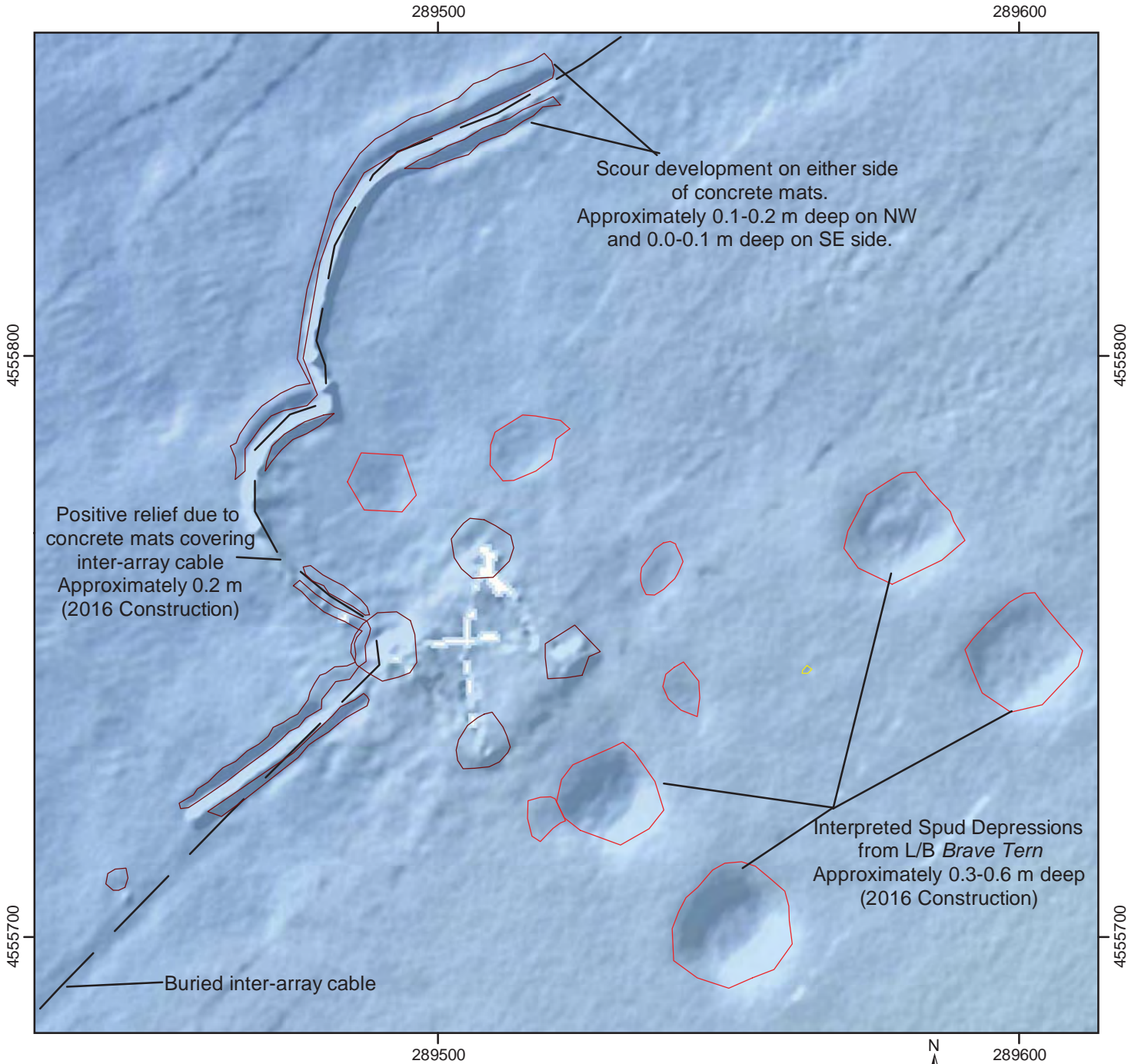

Legend

— Export Cable/Inter Array Cable

Interpreted Seafloor Disturbance Features

- Spud
- Circular Depression
- Scour

September 2018 Fugro Bathymetry (Meter, MLLW)

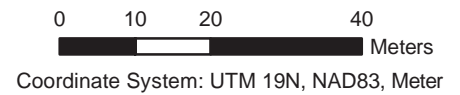
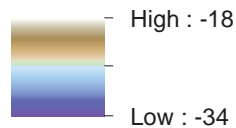

INTERPRETED SEAFLOOR DISTURBANCE TYPES
WIND TURBINE GENERATOR NO. 1
Seafloor Monitoring Study
Block Island Wind Farm and Transmission Project
Offshore Rhode Island

N:\Projects\04_2015\04_8115_0001_BOEM_RODEO\BlockIsland_RIV\Outputs\Post_Con_Survey_5M\XD\Fig-3c_WTG1_Bathymetry_with_Interp.mxd, 7/15/2019, k.smith

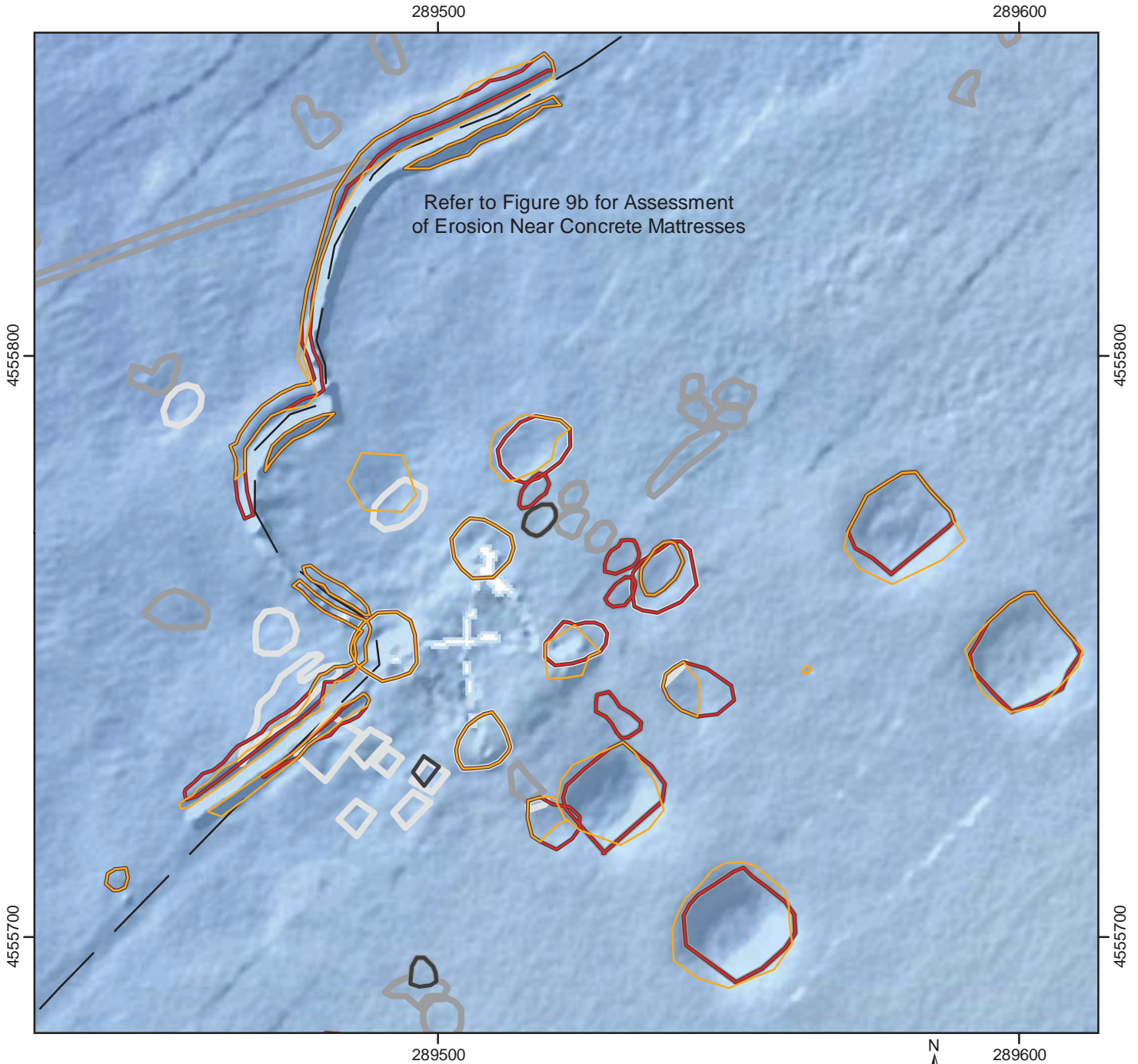

Legend

- Export Cable/Inter Array Cable
- Interpreted Seafloor Disturbance Features**
- Construction Season 1 (May 2016 Data)
- Construction Season 2 (Oct. 2016 Data)
- May 2017 Data □ Sep. 2018 Data
- Oct. 2017 Data

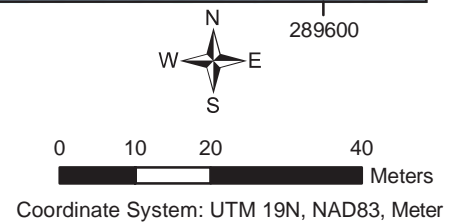

**SEAFLOOR DISTURBANCE PER SURVEY
WIND TURBINE GENERATOR NO. 1**
Seafloor Monitoring Study
Block Island Wind Farm and Transmission Project
Offshore Rhode Island

N:\Projects\04_201504_8115_0001_BOEM_RODEO\BlockIsland_RI\Outputs\Post_Con_Survey_5\MXD\Fig-3d_WTG1_Bathy_Differences.mxd, 8/23/2019, k.smith

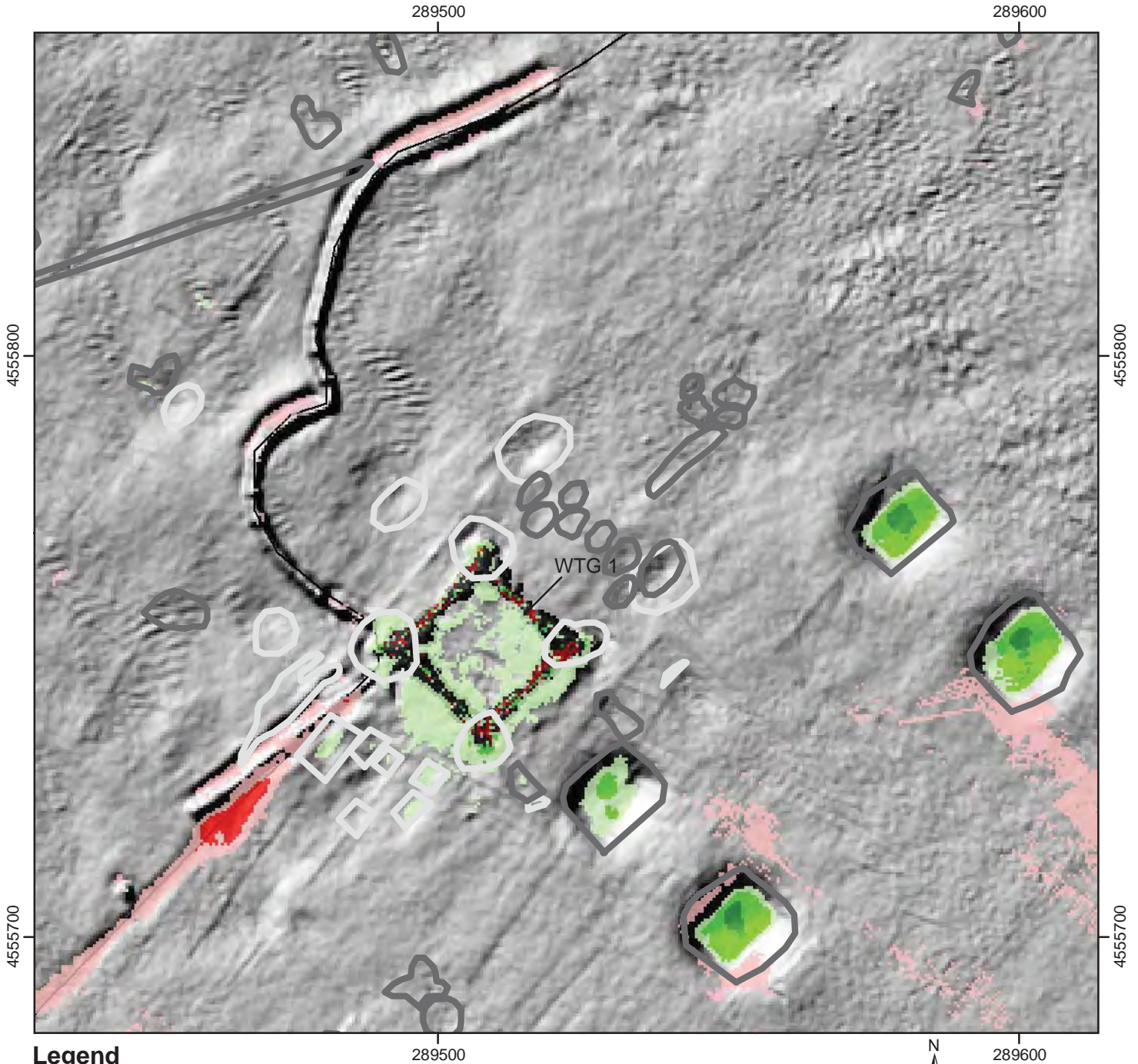

Legend

Difference between Survey 2 and 4 (meters)

- | | | |
|----------------------|--|--|
| Accretion | | More than 0.75 |
| | | 0.75 to 0.5 |
| | | 0.5 to 0.25 |
| | | 0.25 to 0.1 |
| | | -0.1 to 0.1 (No notable change in elevation) |
| Lowering/
Erosion | | -0.1 to -0.25 |
| | | -0.25 to -0.5 |
| | | -0.5 to -0.75 |
| | | More tha -0.75 |

Export Cable/Inter Array Cable



Coordinate System: UTM 19N, NAD83, Meter

**DIFFERENCE BETWEEN SURVEY 2 AND 4 BATHYMETRY
WIND TURBINE GENERATOR NO. 1**

Seafloor Monitoring Study
Block Island Wind Farm and Transmission Project
Offshore Rhode Island

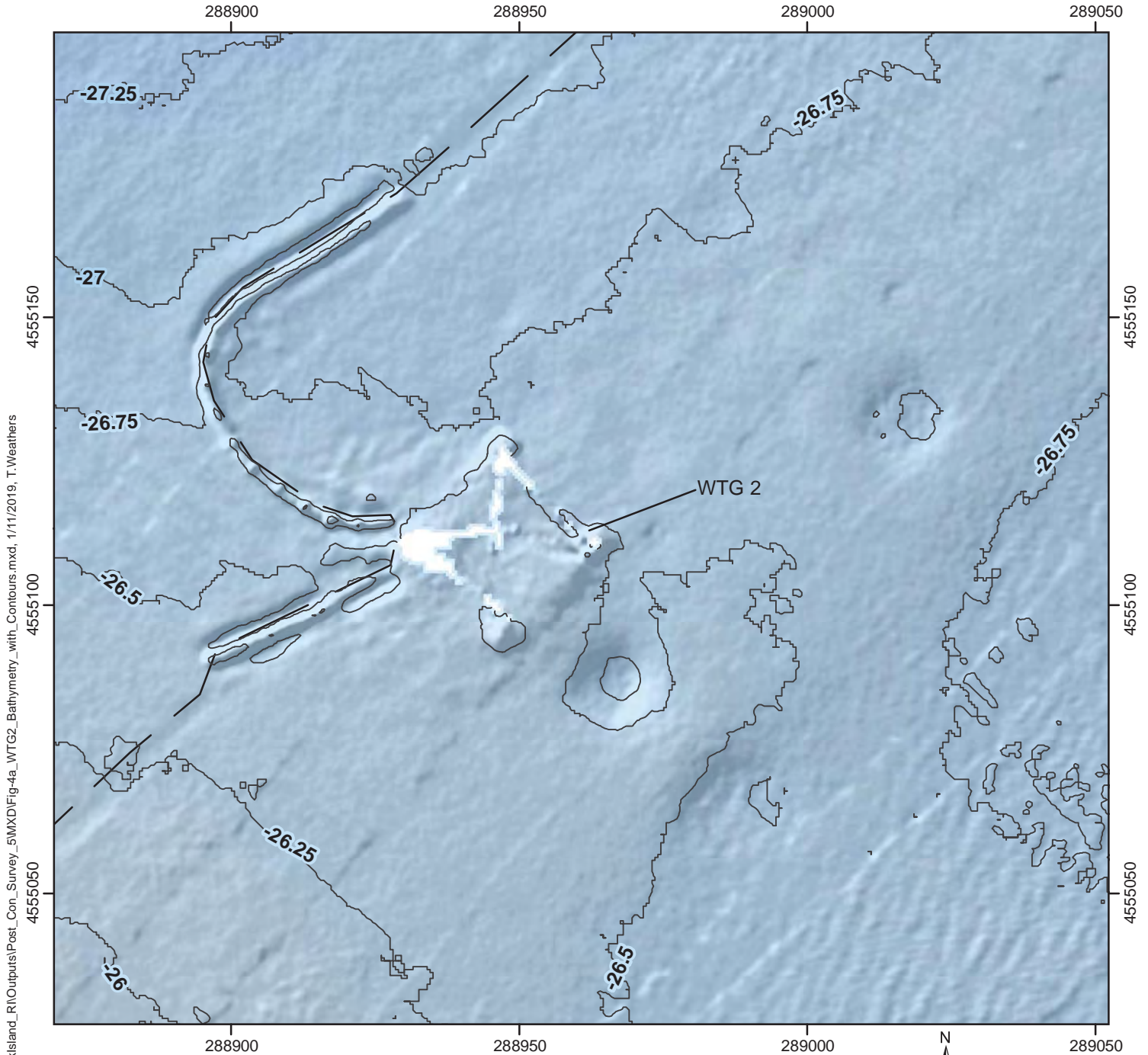

Legend

— Export Cable/Inter Array Cable

**September 2018 Fugro Bathymetry
(Meter, MLLW)**

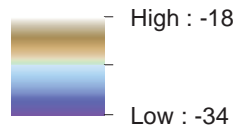

— Contour interval is 0.25 meters



Coordinate System: UTM 19N, NAD83, Meter

**BATHYMETRY
WIND TURBINE GENERATOR NO. 2**
Seafloor Monitoring Study
Block Island Wind Farm and Transmission Project
Offshore Rhode Island

N:\Projects\04_2015\04_8115_0001_BOEM_RODEO\BlockIsland_RIV\Outputs\Post_Con_Survey_51MXD\Fig-4a_WTG2_Bathymetry_with_Contours.mxd, 1/11/2019, T.Weathers

N:\Projects\04_2015\04_8115_0001_BOEM_RODEO\BlockIsland_RIVOutputs\Post_Con_Survey_5M\XD\Fig-4b_WT02_Bathymetry_with_Interp.mxd, 1/11/2019, T.Weathers

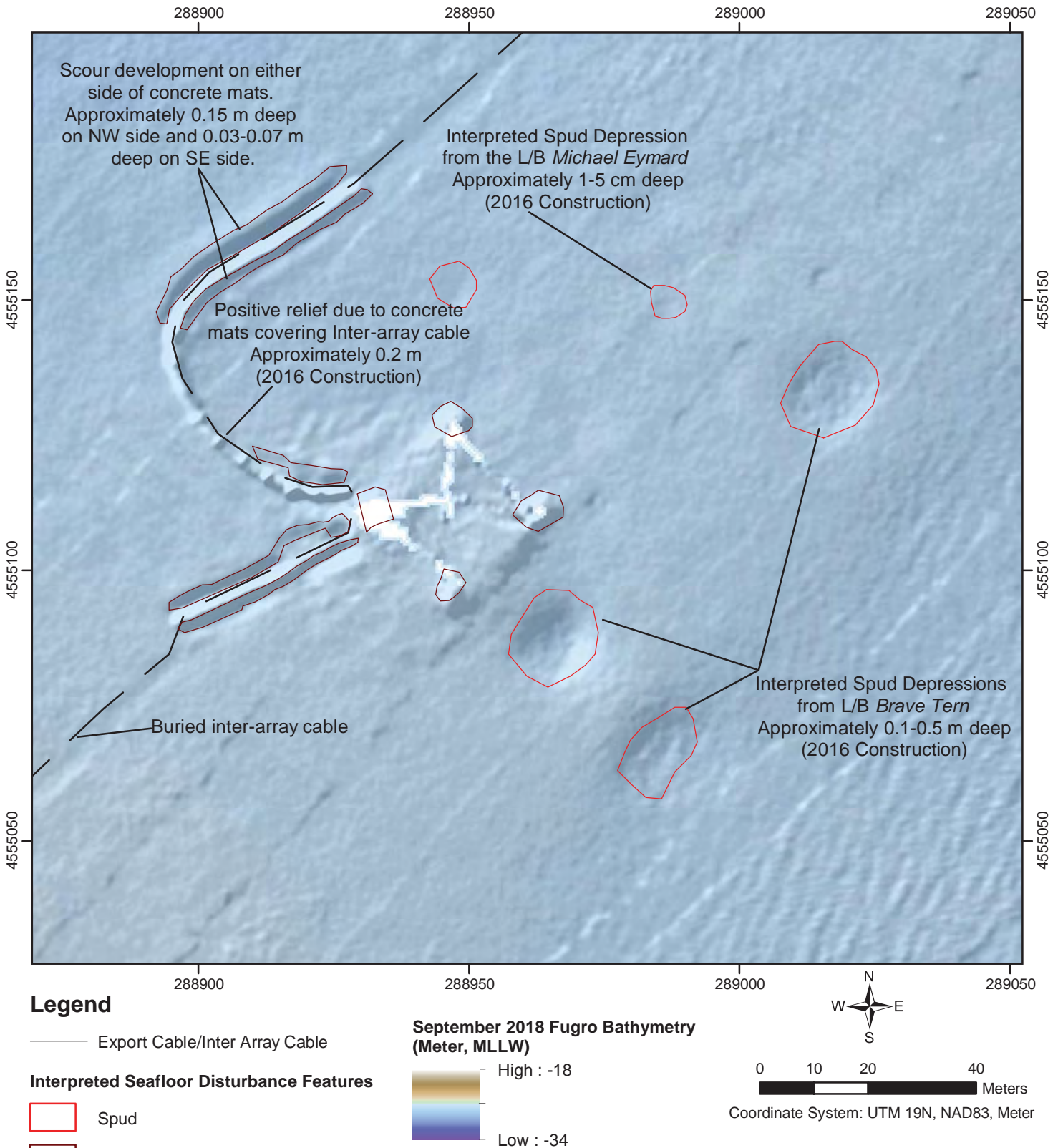

INTERPRETED SEAFLOOR DISTURBANCE TYPES
WIND TURBINE GENERATOR NO. 2
 Seafloor Monitoring Study
 Block Island Wind Farm and Transmission Project
 Offshore Rhode Island

N:\Projects\04_2015\04_8115_0001_BOEM_RODEO\BlockIsland_RIVOutputs\Post_Con_Survey_5M\XD\Fig-4c_WT62_Bathymetry_with_Interp.mxd, 1/11/2019, T.Weathers

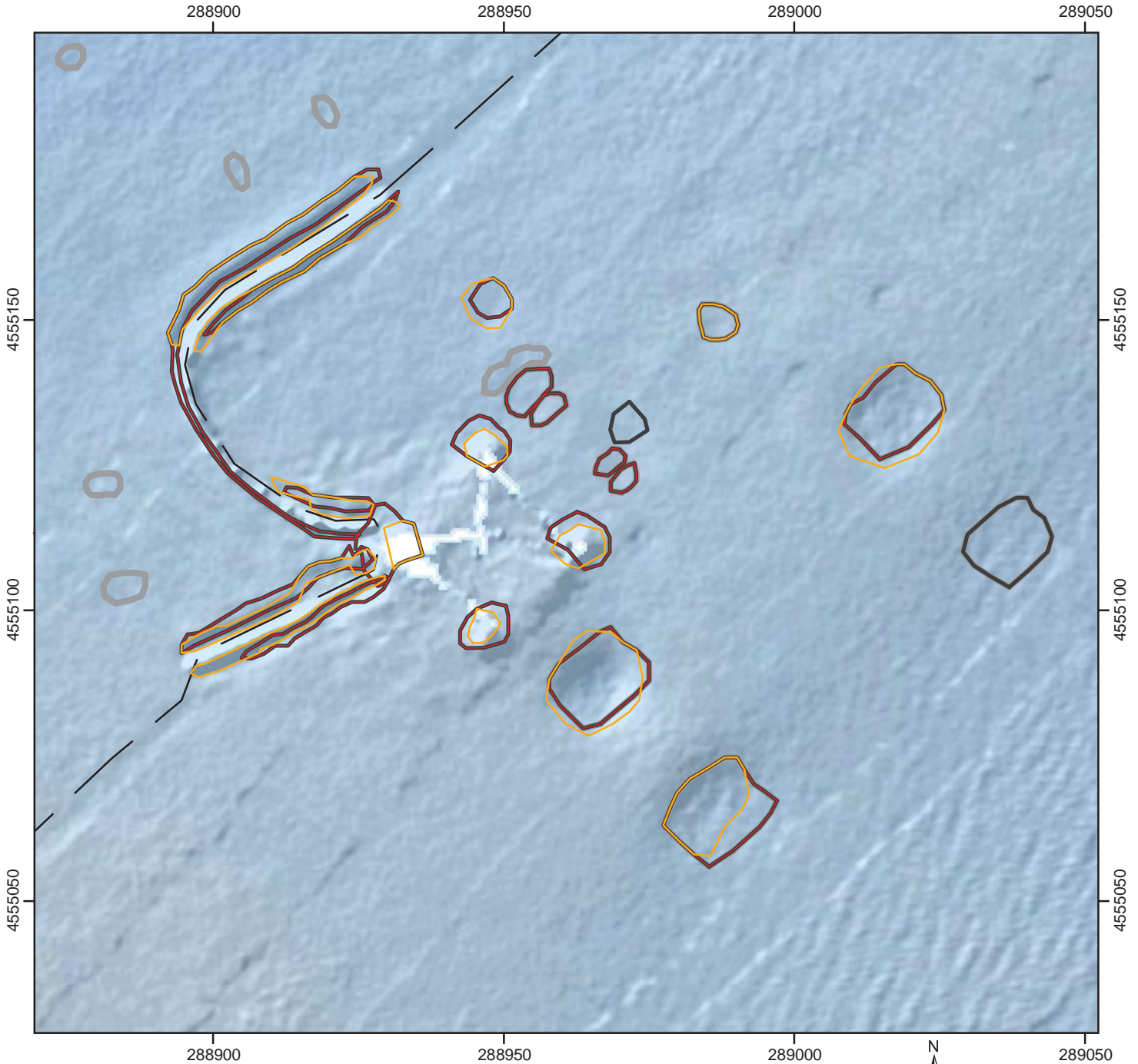

Legend

- Export Cable/Inter Array Cable
- Interpreted Seafloor Disturbance Features**
- Construction Season 1 (May 2016 Data)
- Construction Season 2 (Oct. 2016 Data)
- May 2017 Data □ Sep. 2018 Data
- Oct. 2017 Data

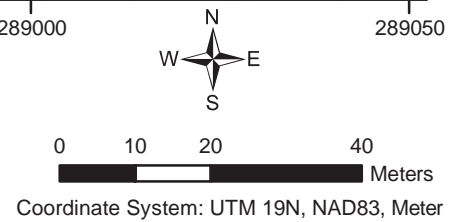

**SEAFLOOR DISTURBANCE PER SURVEY
WIND TURBINE GENERATOR NO. 2**
Seafloor Monitoring Study
Block Island Wind Farm and Transmission Project
Offshore Rhode Island

N:\Projects\04_2015\04_8115_0001_BOEM_RODEO\BlockIsland_RI\Outputs\Post_Con_Survey_5\MXD\Fig-4d_WTG2_Bathy_Differences.mxd, 8/23/2019, k.smith

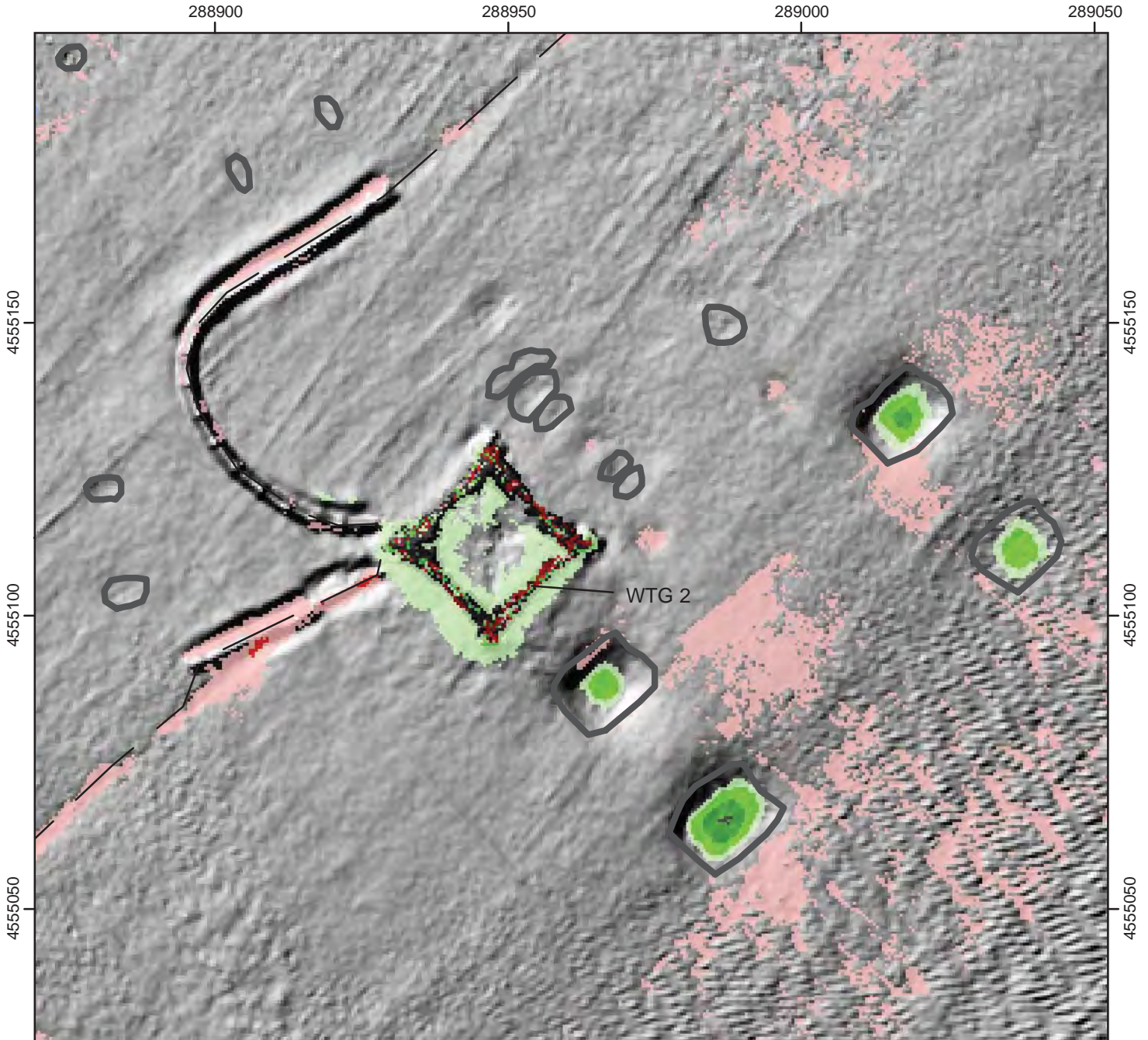

Legend

Difference between Survey 2 and 4 (meters)

- | | | |
|----------------------|--|--|
| Accretion | | More than 0.75 |
| | | 0.75 to 0.5 |
| | | 0.5 to 0.25 |
| | | 0.25 to 0.1 |
| Lowering/
Erosion | | -0.1 to 0.1 (No notable change in elevation) |
| | | -0.1 to -0.25 |
| | | -0.25 to -0.5 |
| | | -0.5 to -0.75 |
| | | More than -0.75 |

Export Cable/Inter Array Cable



Coordinate System: UTM 19N, NAD83, Meter

BATHYMETRY DIFFERENCES
WIND TURBINE GENERATOR NO. 2
 Seafloor Monitoring Study
 Block Island Wind Farm and Transmission Project
 Offshore Rhode Island

N:\Projects\04_2015\04_8115_0001_BOEM_RODEO\BlockIsland_RIVOutputs\Post_Con_Survey_5M\XD\Fig-5a_WTG3_Bathymetry_with_Contours.mxd, 1/11/2019, T.Weathers

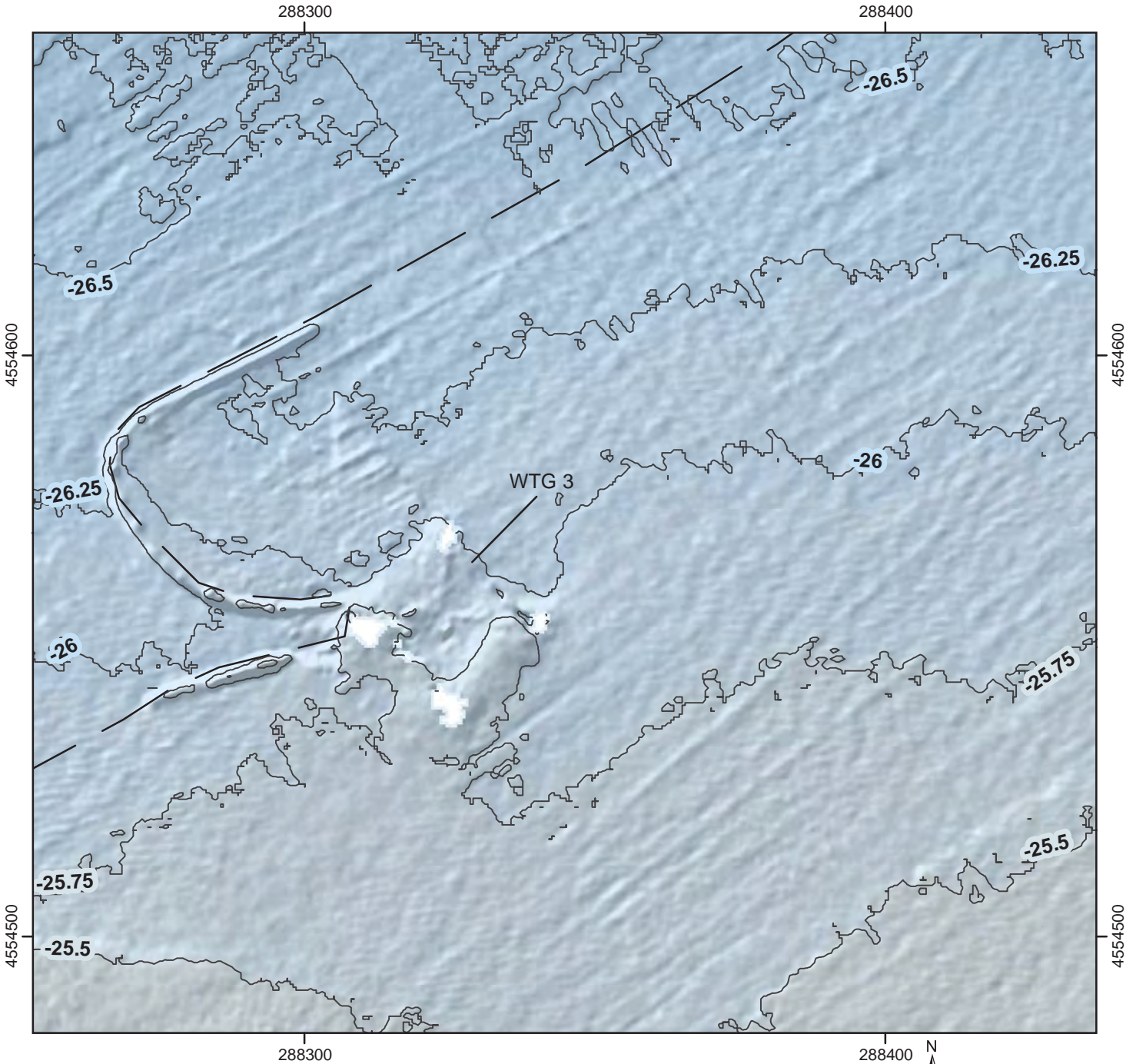

Legend

— Export Cable/Inter Array Cable

**September 2018 Fugro Bathymetry
(Meter, MLLW)**

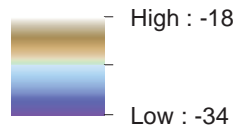

Low : -34

— Contour interval is 0.25 meters

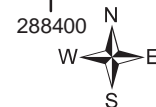

Coordinate System: UTM 19N, NAD83, Meter

**BATHYMETRY
WIND TURBINE GENERATOR NO. 3
Seafloor Monitoring Study
Block Island Wind Farm and Transmission Project
Offshore Rhode Island**

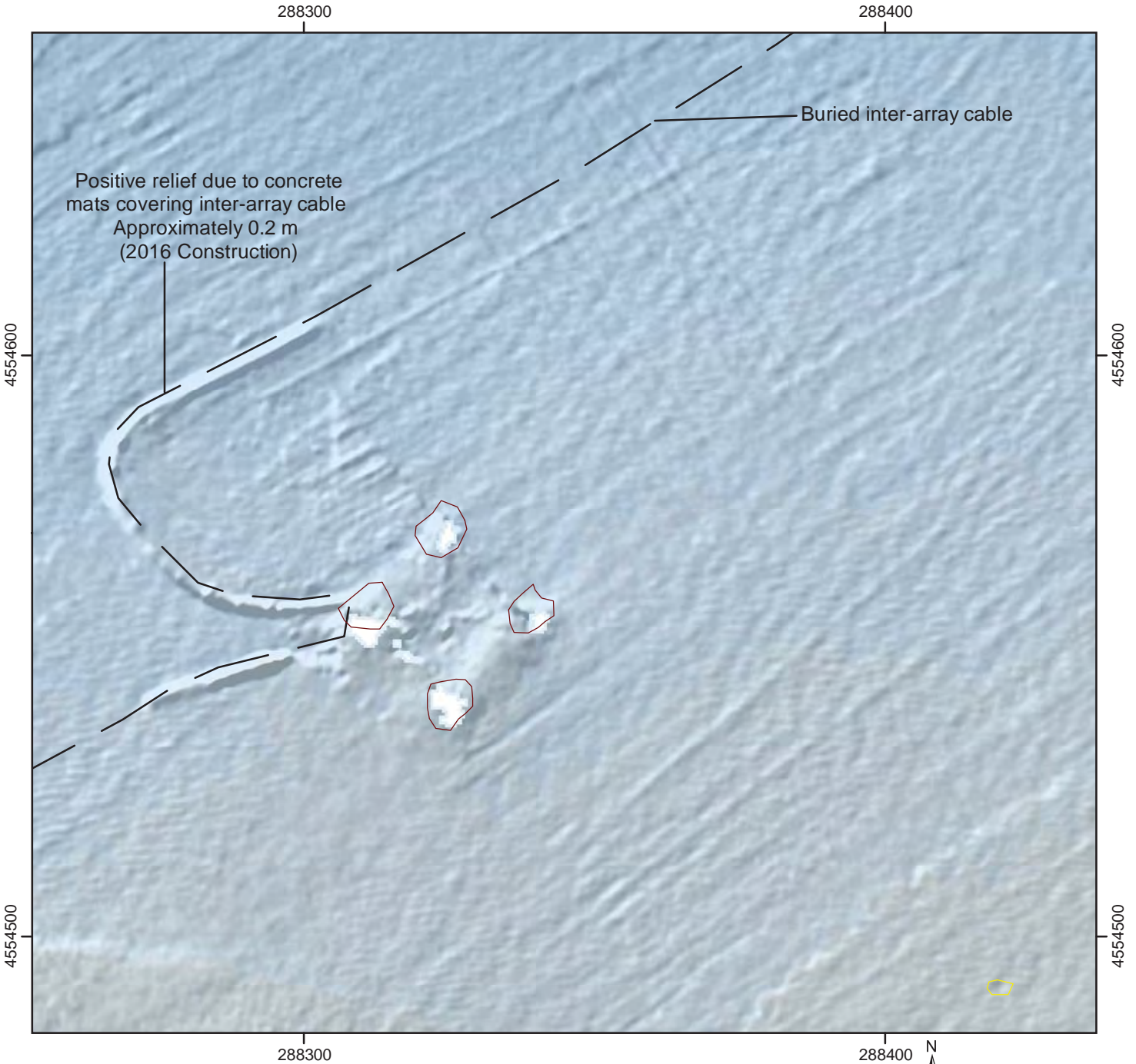

Legend

— Export Cable/Inter Array Cable

Interpreted Seafloor Disturbance Features

- Circular Depression
- Scour

**September 2018 Fugro Bathymetry
(Meter, MLLW)**

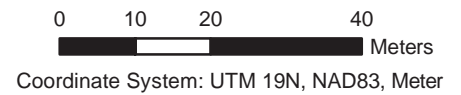
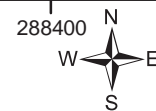
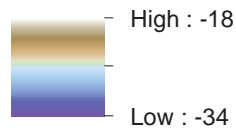

**INTERPRETED SEAFLOOR DISTURBANCE TYPES
WIND TURBINE GENERATOR NO. 3**
Seafloor Monitoring Study
Block Island Wind Farm and Transmission Project
Offshore Rhode Island

N:\Projects\04_2015\04_8115_0001_BOEM_RODEO\BlockIsland_RIV\Outputs\Post_Con_Survey_5M\XD\Fig-5b_WTGS_Bathymetry_with_Interp.mxd, 1/11/2019, T.Weathers

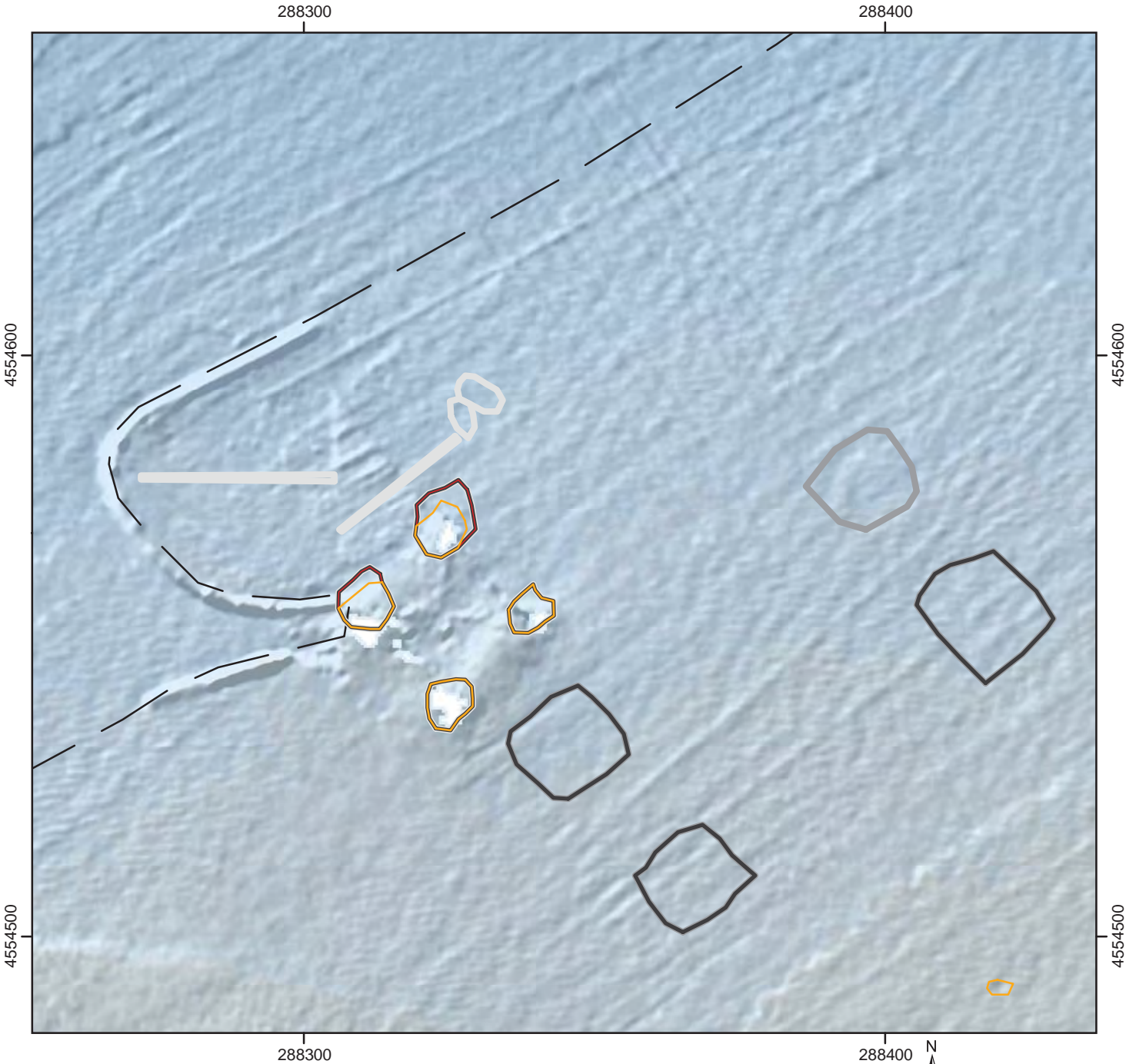

Legend

— Export Cable/Inter Array Cable

Interpreted Seafloor Disturbance Features

- Construction Season 1 (May 2016 Data)
- Construction Season 2 (Oct. 2016 Data)
- May 2017 Data
- Oct. 2017 Data
- Sep. 2018 Data

September 2018 Fugro Bathymetry (Meter, MLLW)

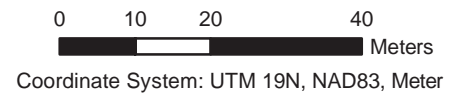
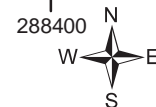
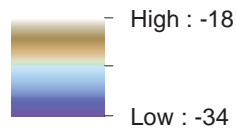

**SEAFLOOR DISTURBANCE PER SURVEY
WIND TURBINE GENERATOR NO. 3**
Seafloor Monitoring Study
Block Island Wind Farm and Transmission Project
Offshore Rhode Island

N:\Projects\04_2015\04_8115_0001_BOEM_RODEO\BlockIsland_RIO\outputs\Post_Con_Survey_5\MXD\Fig-5c_WTGS3_Bathymetry_with_Interp.mxd, 1/11/2019, T.Weathers

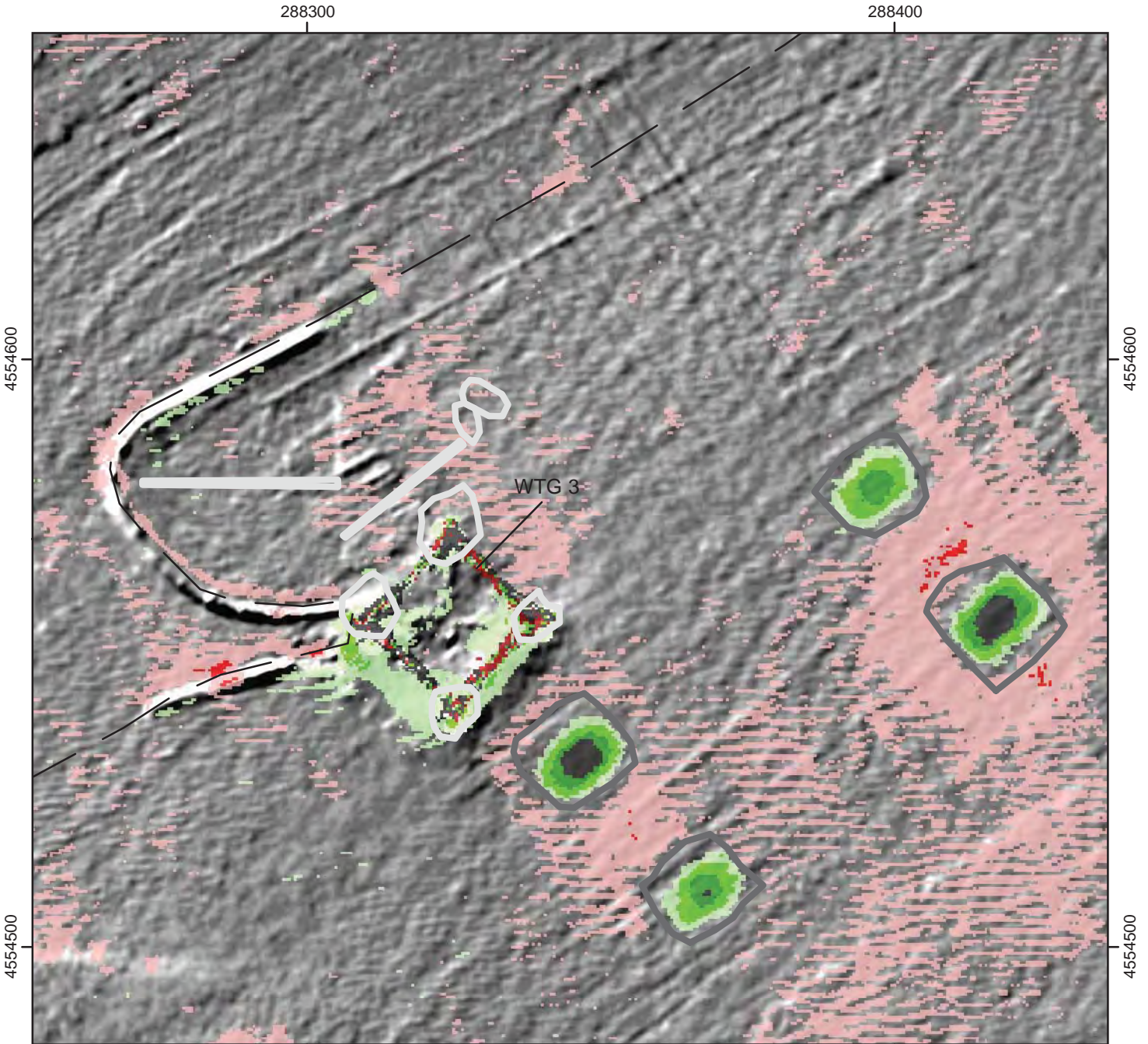

Legend

Difference between Survey 2 and 4 (meters)

- | | | |
|----------------------|--|--|
| Accretion | | More than 0.75 |
| | | 0.75 to 0.5 |
| | | 0.5 to 0.25 |
| | | 0.25 to 0.1 |
| | | -0.1 to 0.1 (No notable change in elevation) |
| Lowering/
Erosion | | -0.1 to -0.25 |
| | | -0.25 to -0.5 |
| | | -0.5 to -0.75 |
| | | More than -0.75 |

Export Cable/Inter Array Cable

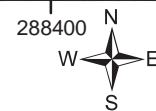

0 10 20 40
Meters

Coordinate System: UTM 19N, NAD83, Meter

**BATHYMETRY DIFFERENCES
WIND TURBINE GENERATOR NO. 3**
Seafloor Monitoring Study
Block Island Wind Farm and Transmission Project
Offshore Rhode Island

N:\Projects\04_2015\04_8115_0001_BOEM_RODEO\BlockIsland_RI\Outputs\Post_Con_Survey_5\MXD\Fig-5d_WTG3_Bathy_Differences.mxd, 8/23/2019, k.smith



N:\Projects\04_2015\04_8115_0001_BOEM_RODEO\BlockIsland_R1\Outputs\Post_Con_Survey_5\IMXD\Fig-6a_WTG4_Bathymetry_with_Contours.mxd, 1/1/2019, T.Weathers

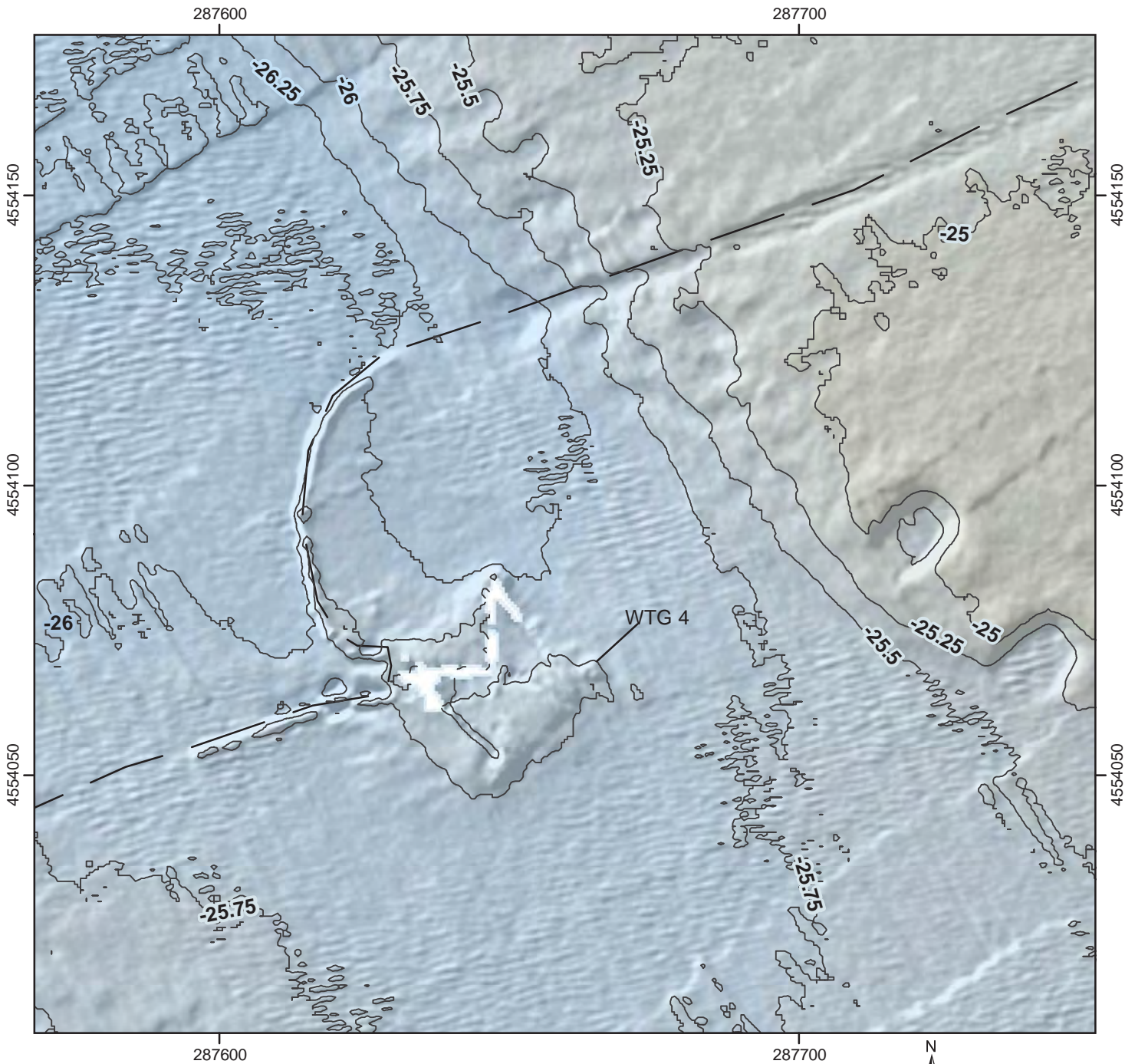

Legend

— Export Cable/Inter Array Cable

**September 2018 Fugro Bathymetry
(Meter, MLLW)**

High : -18



Low : -34

— Contour interval is 0.25 meters



Coordinate System: UTM 19N, NAD83, Meter

BATHYMETRY
WIND TURBINE GENERATOR NO. 4
Seafloor Monitoring Study
Block Island Wind Farm and Transmission Project
Offshore Rhode Island

N:\Projects\04_2015\04_8115_0001_BOEM_RODEO\BlockIsland_R\Outputs\Post_Con_Survey_5\IMXD\Fig-6b_WTG4_Bathymetry_with_Interp.mxd, 1/11/2019, T. Weathers

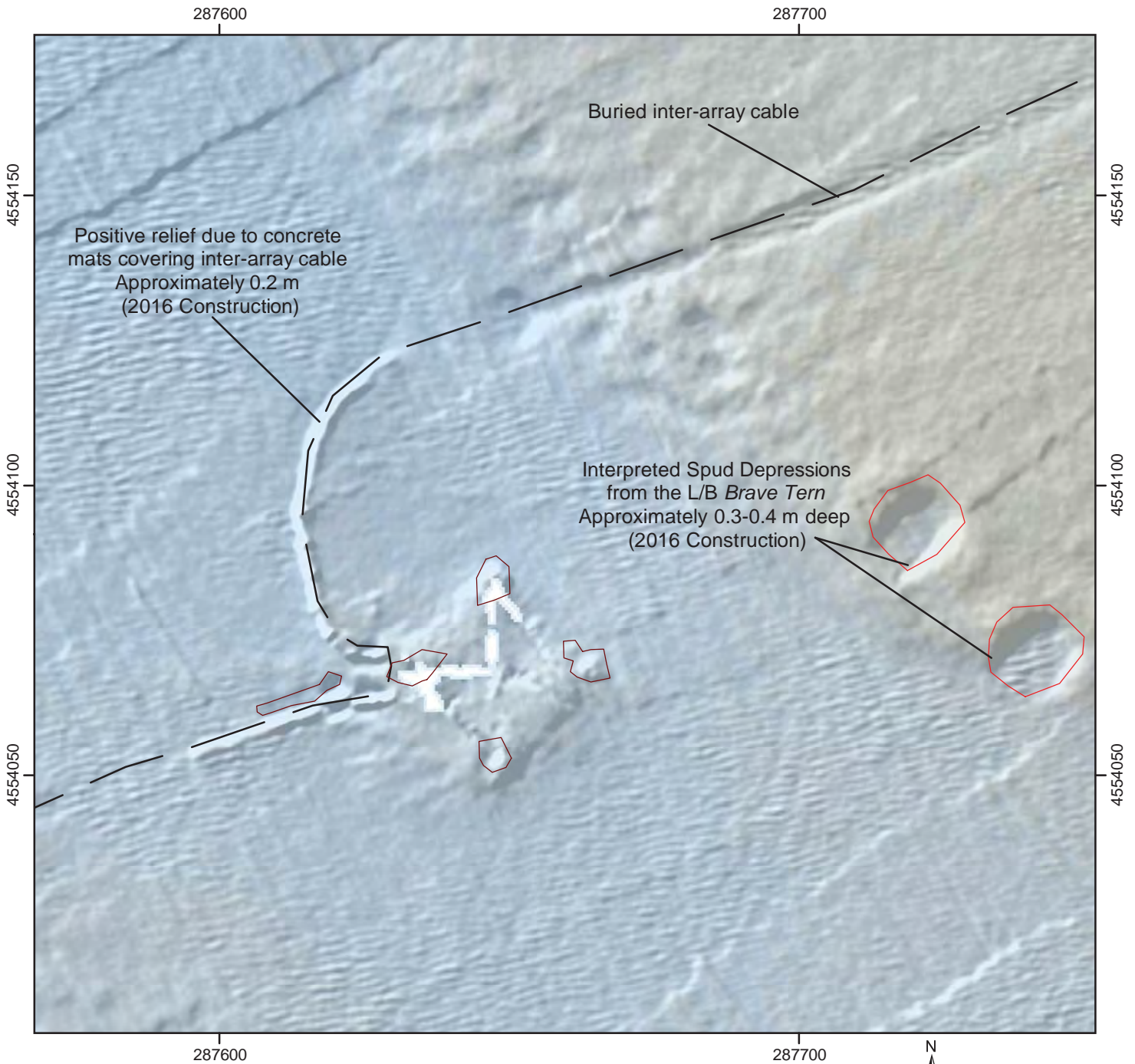

Legend

— Export Cable/Inter Array Cable

Interpreted Seafloor Disturbance Features

- Spud
- Scour

September 2018 Fugro Bathymetry (Meter, MLLW)

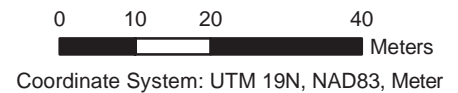
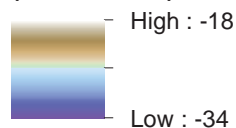

INTERPRETED SEAFLOOR DISTURBANCE TYPES
WIND TURBINE GENERATOR NO. 4
 Seafloor Monitoring Study
 Block Island Wind Farm and Transmission Project
 Offshore Rhode Island

N:\Projects\04_2015\04_8115_0001_BOEM_RODEO\BlockIsland_R10Outputs\Post_Con_Survey_5MXXD\Fig-6c_WTC4_Bathymetry_with_Interp.mxd, 1/11/2019, T.Weathers

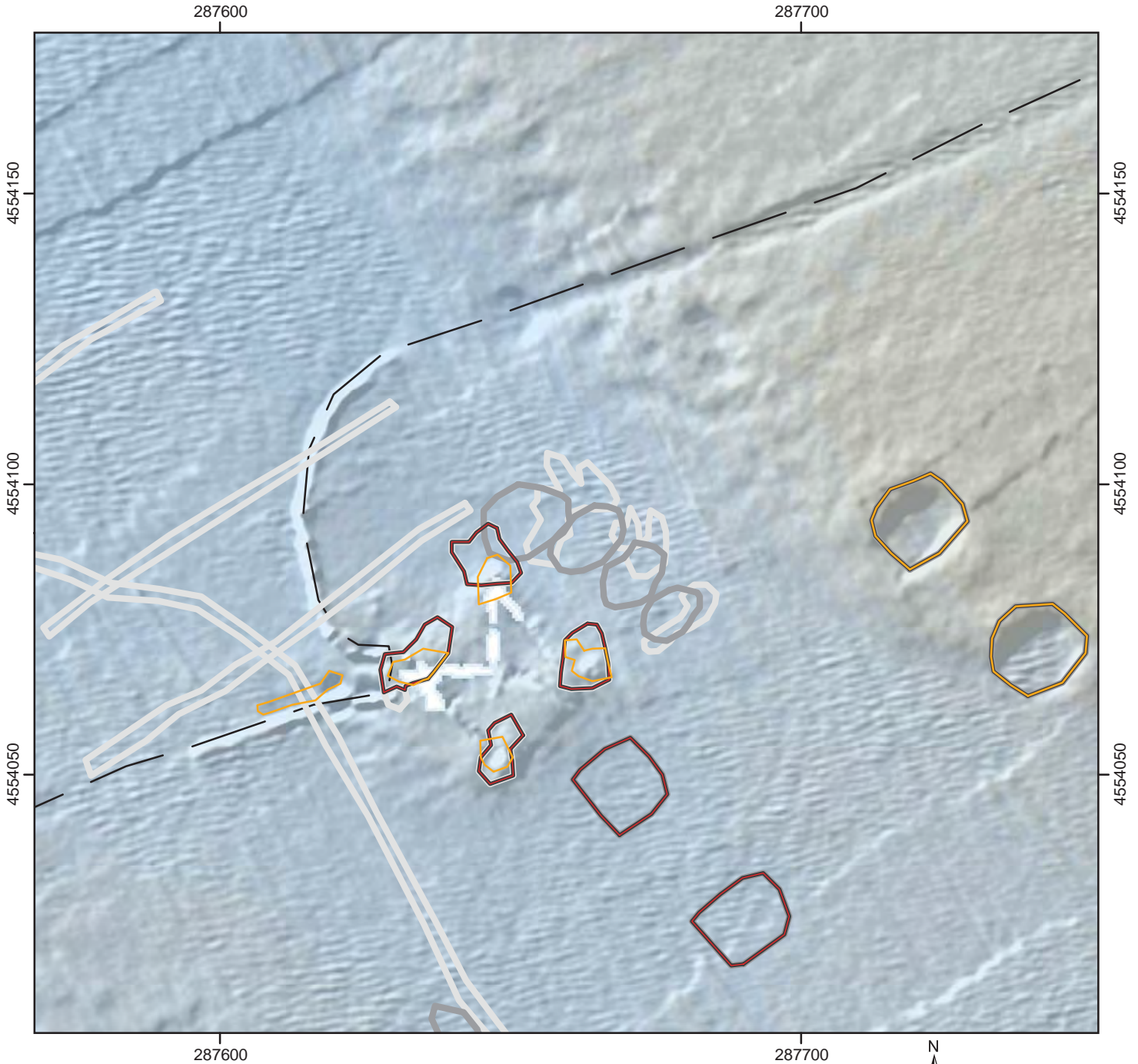

Legend

- Export Cable/Inter Array Cable
- Interpreted Seafloor Disturbance Features**
- Construction Season 1 (May 2016 Data)
- Construction Season 2 (Oct. 2016 Data)
- May 2017 Data Sep. 2018 Data
- Oct. 2017 Data

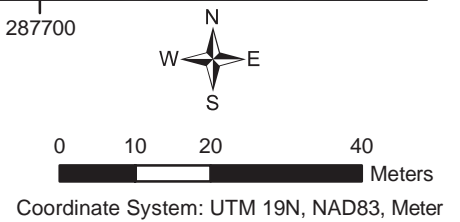

**SEAFLOOR DISTURBANCE PER SURVEY
WIND TURBINE GENERATOR NO. 4**
Seafloor Monitoring Study
Block Island Wind Farm and Transmission Project
Offshore Rhode Island

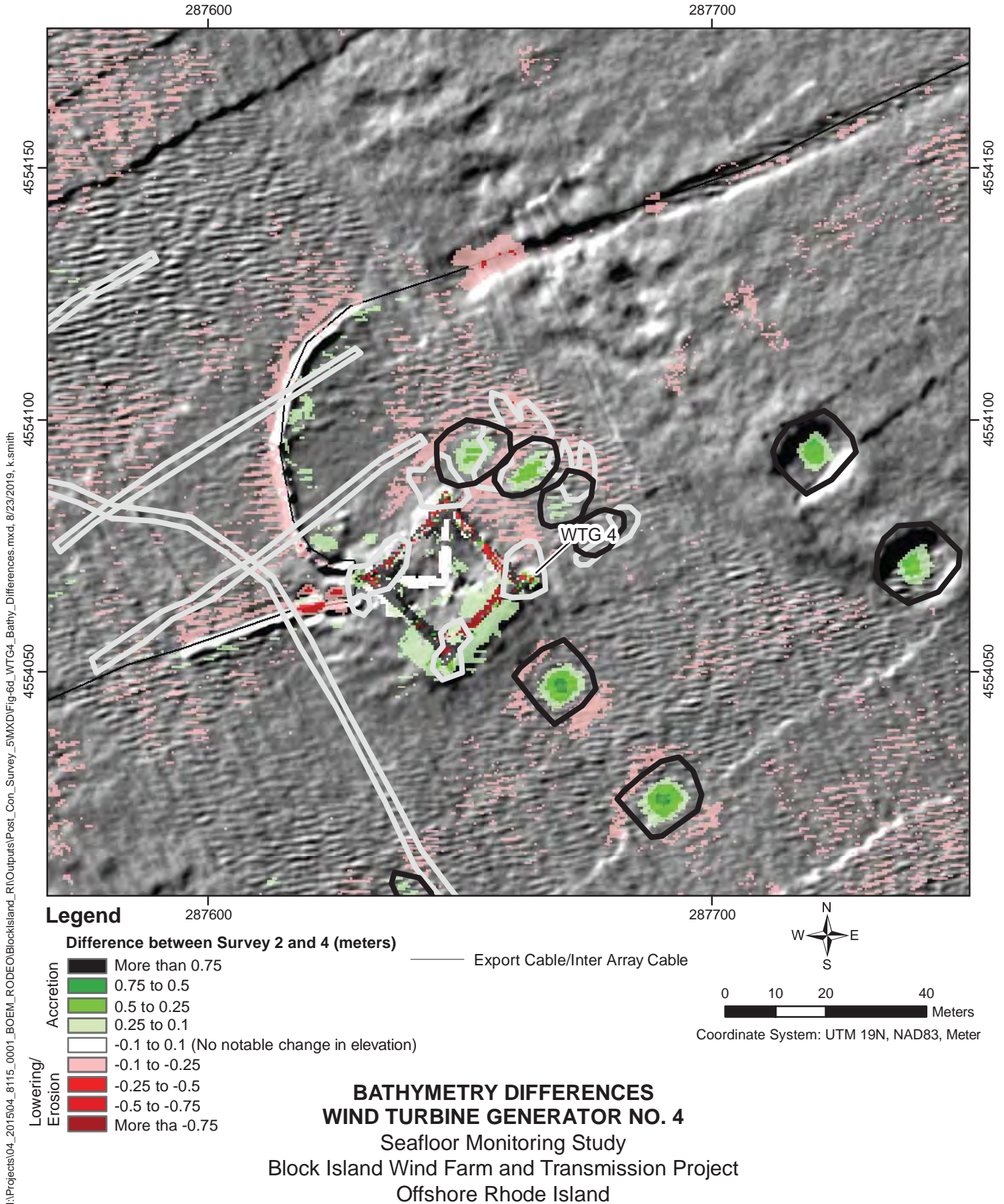

N:\Projects\04_2015\04_8115_0001_BOEM_RODEO\BlockIsland_RI\Outputs\Post_Con_Survey_5\MXD\Fig-6d_WTG4_Bathy_Differences.mxd, 8/23/2019, k.smith

N:\Projects\04_2015\04_8115_0001_BOEM_RODEO\BlockIsland_RIO\Outputs\Post_Con_Survey_5\IMXD\Fig-7a_WTG5_Bathymetry_with_Contours.mxd, 1/1/2019, T.Weathers

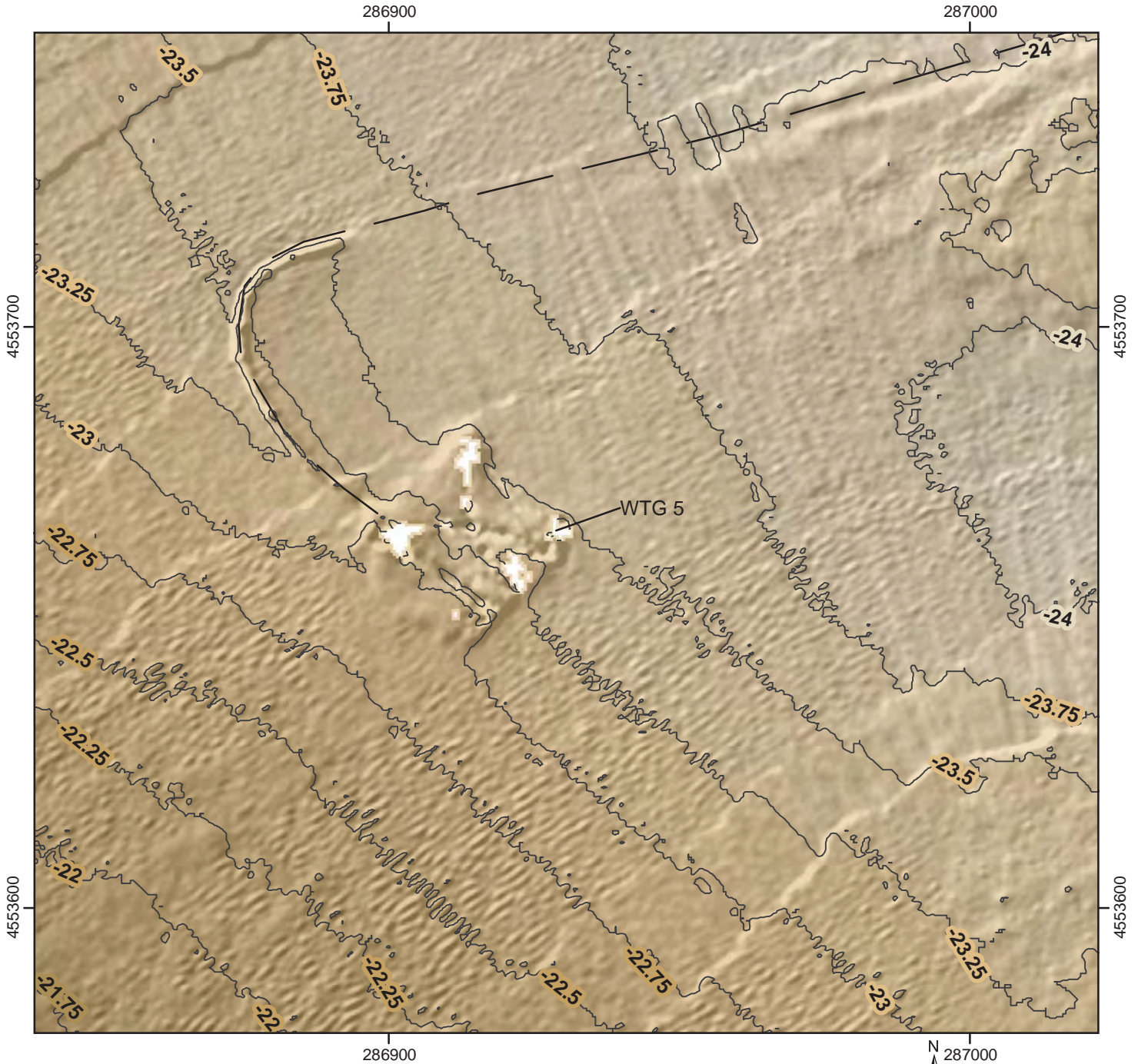

Legend

— Export Cable/Inter Array Cable

September 2018 Fugro Bathymetry (Meter, MLLW)

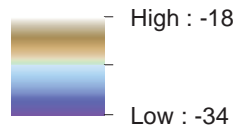

High : -18

Low : -34

Contour interval is 0.25 meters



Coordinate System: UTM 19N, NAD83, Meter

BATHYMETRY
WIND TURBINE GENERATOR NO. 5
Seafloor Monitoring Study
Block Island Wind Farm and Transmission Project
Offshore Rhode Island

N:\Projects\04_2015\04_8115_0001_BOEM_RODEO\BlockIsland_R\Outputs\Post_Con_Survey_51MXD\Fig-7b_WTGS_Bathymetry_with_Interp.mxd, 1/11/2019, T.Weathers



Legend

— Export Cable/Inter Array Cable

Interpreted Seafloor Disturbance Features

□ Scour

**September 2018 Fugro Bathymetry
(Meter, MLLW)**

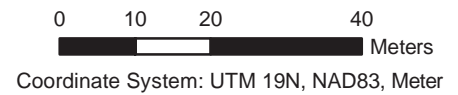
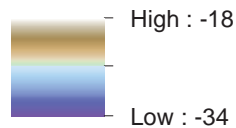

**INTERPRETED SEAFLOOR DISTURBANCE TYPES
WIND TURBINE GENERATOR NO. 5**
Seafloor Monitoring Study
Block Island Wind Farm and Transmission Project
Offshore Rhode Island

N:\Projects\04_2015\04_8115_0001_BOEM_RODEO\BlockIsland_RIVOutputs\Post_Con_Survey_5M\XD\Fig-7c_WT65_Bathymetry_with_Interp.mxd, 1/11/2019, T.Weathers



Legend

— Export Cable/Inter Array Cable

Interpreted Seafloor Disturbance Features

- Construction Season 1 (May 2016 Data)
- Construction Season 2 (Oct. 2016 Data)
- May 2017 Data Sep. 2018 Data
- Oct. 2017 Data

September 2018 Fugro Bathymetry (Meter, MLLW)

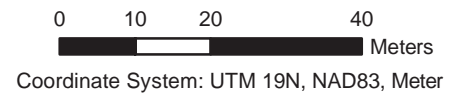
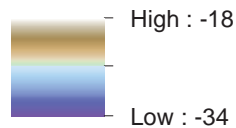

SEAFLOOR DISTURBANCE PER SURVEY
WIND TURBINE GENERATOR NO. 5
 Seafloor Monitoring Study
 Block Island Wind Farm and Transmission Project
 Offshore Rhode Island

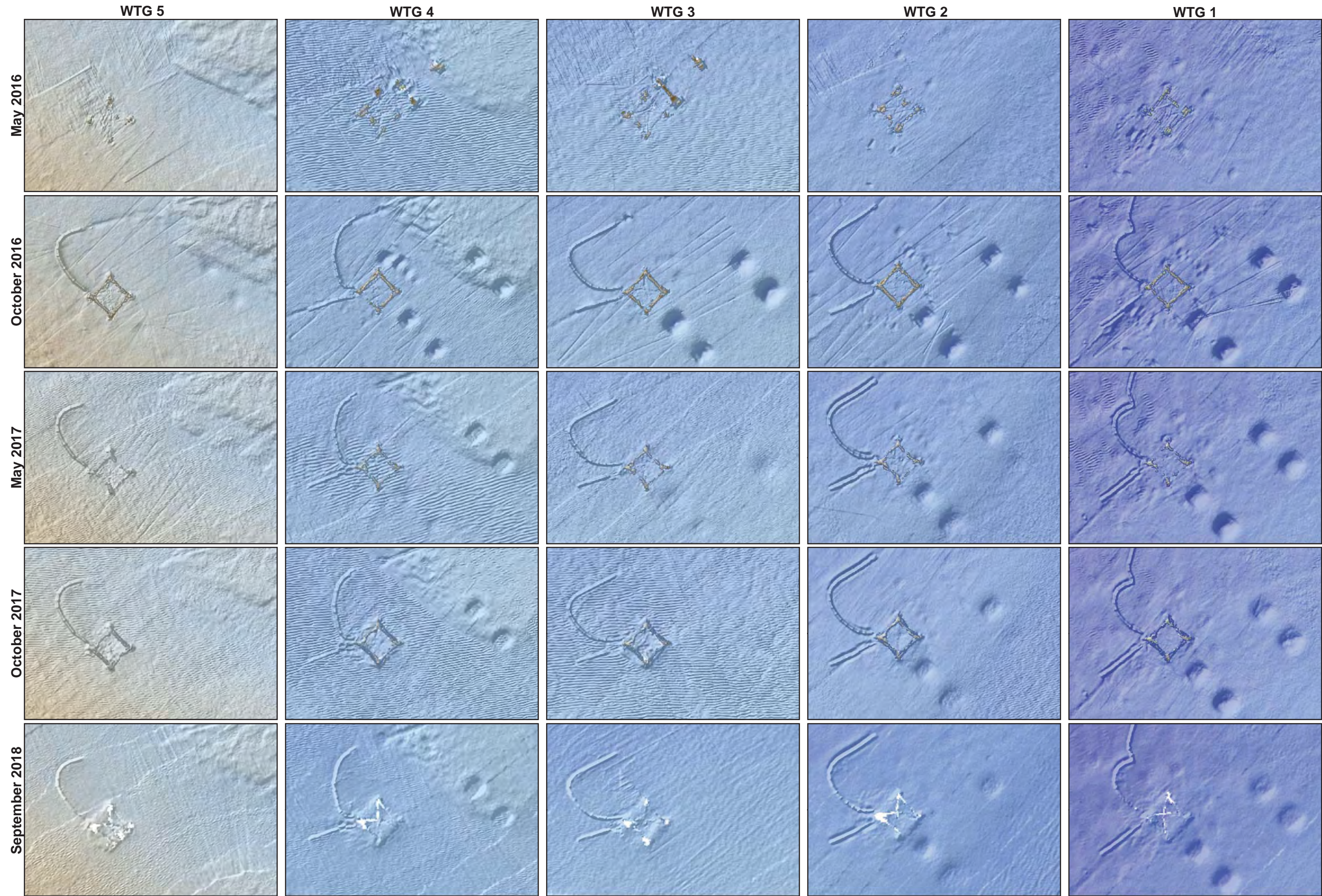

Legend

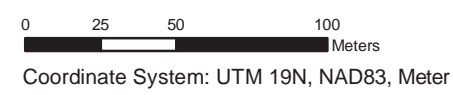

Fugro Bathymetry (Meter, MLLW)

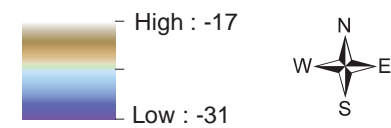

BATHYMETRY COMPARISON
Seafloor Monitoring Study
Block Island Wind Farm and Transmission Project
Offshore Rhode Island

N:\Projects\04_201504_8115_0001_BOEM_RODEO\BlockIsland_RV\Outputs\Post_Con_Survey_4M\XD\Fig-8_Time_Series_All.mxd_12/21/2018_T.Weathers

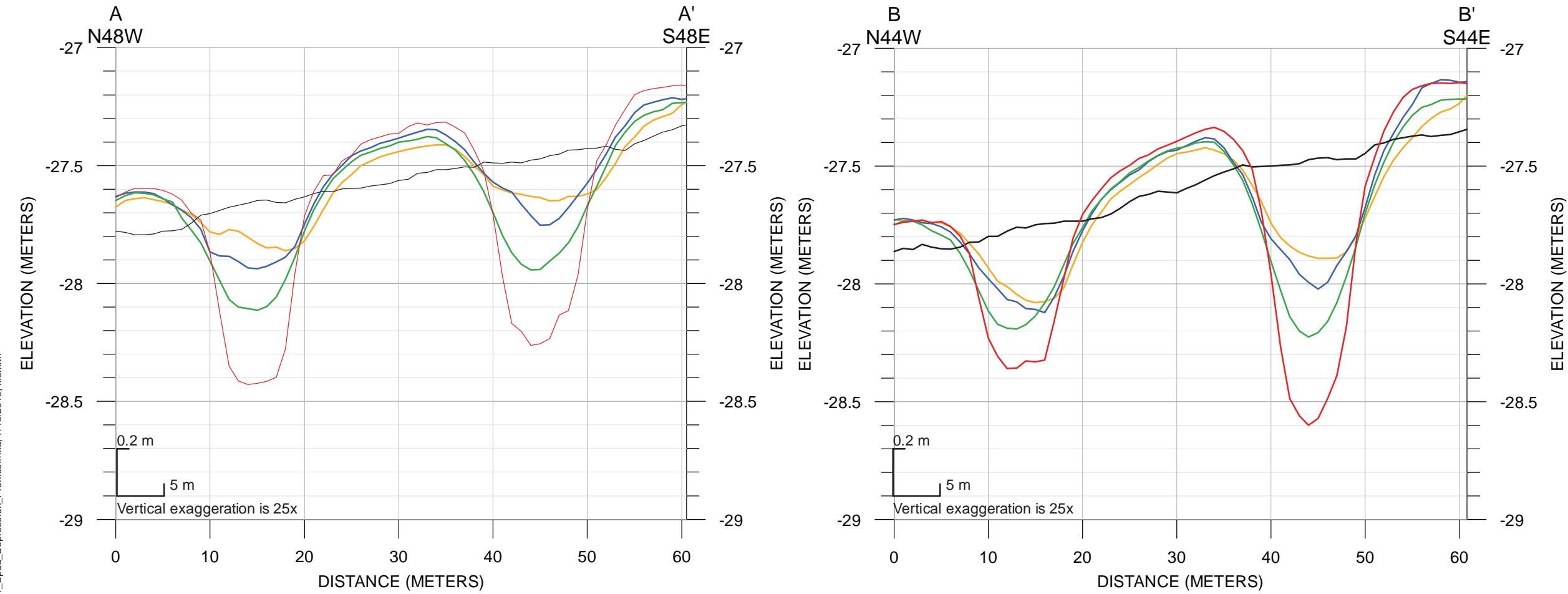

- Legend**
- Survey No. 1 (May 2016)
 - Survey No. 2 (October 2016)
 - Survey No. 3 (May 2017)
 - Survey No. 4 (October 2017)
 - Survey No. 5 (September 2018)

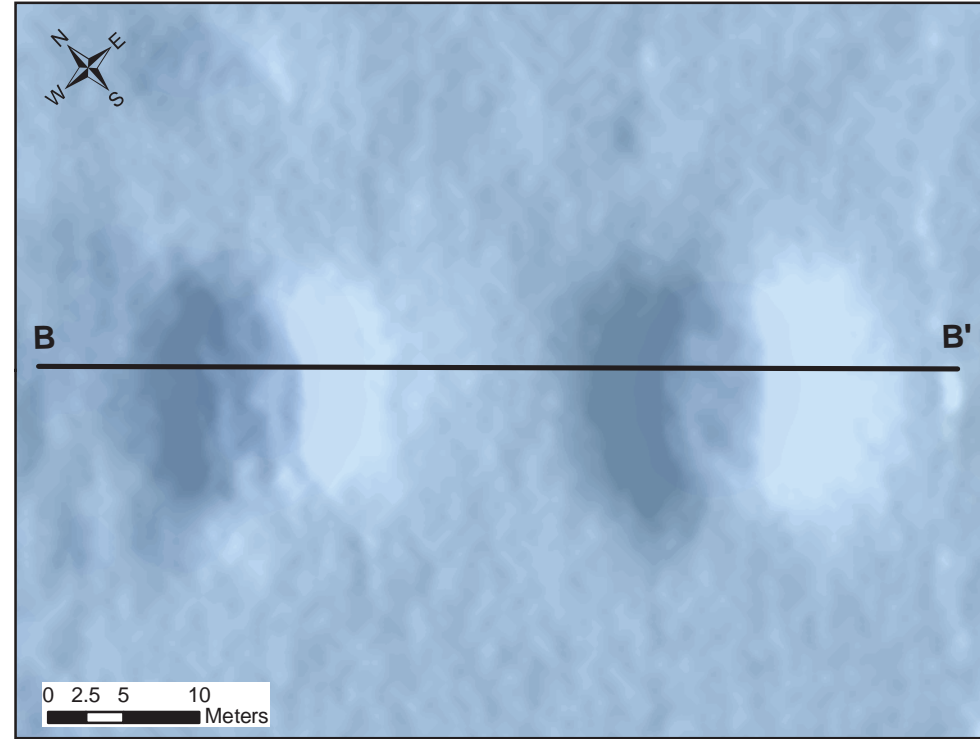
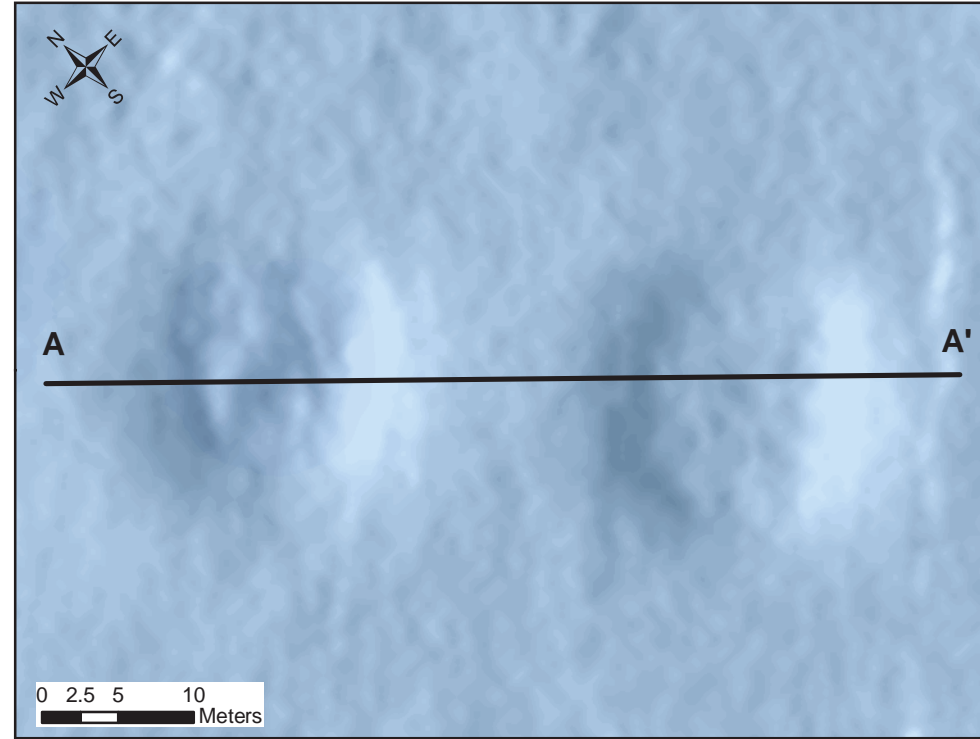
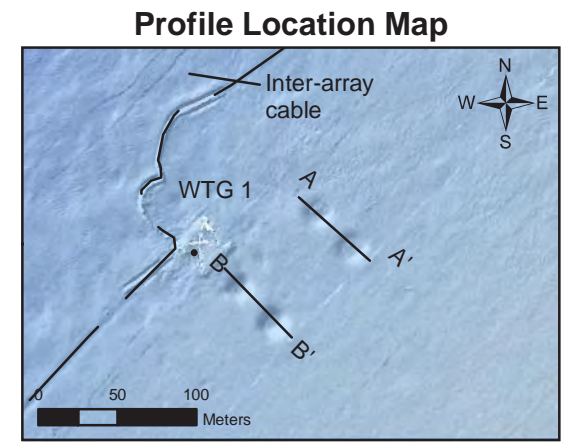

Notes:
The depressions shown in this figure were created by the L/B Brave Tern vessel while installing the wind turbine during Construction Season 2 that occurred in between Surveys 1 and 2. Bathymetry data shown in the plan views are from Survey 5.

**EXAMPLE OF SEAFLOOR RECOVERY
WIND TURBINE GENERATOR NO. 1**
Seafloor Monitoring Study
Block Island Wind Farm and Transmission Project
Offshore Rhode Island

N:\Projects\04_201504_8115_0001_BOEM_BLOCKISLAND_R1\Outputs\Post_Con_Survey_5\WXD\Fig-9_WTG1_Spud_Depression_Profiles.mxd, 7/15/2019, k.smith

Legend

- Survey No. 1 (May 2016)
- Survey No. 2 (October 2016)
- Survey No. 3 (May 2017)
- Survey No. 4 (October 2017)
- Survey No. 5 (September 2018)

Profile Location Map

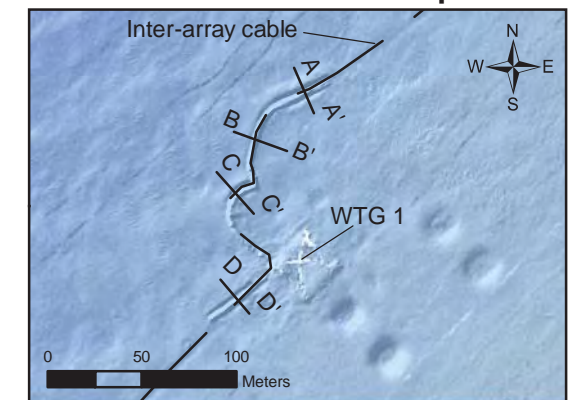

Notes:

Survey 1 was conducted before the cable and concrete mattresses were installed.

Principle tidal axis is aligned in the NNW-SSE direction. Cable segment in Profile B is nearly aligned with the principle tidal axis and shows the least amount of scour. Cable segments shown in Profiles A, C, and D are oriented perpendicular to the principle tidal axis. Scour is most prevalent on the northern side of the cable/concrete mattresses which indicates the dominant tidal current flow at this location is likely to the NNW (flood tidal current direction).

**EXAMPLE OF SEAFLOOR RECOVERY
WIND TURBINE GENERATOR NO. 1**
Seafloor Monitoring Study
Block Island Wind Farm and Transmission Project
Offshore Rhode Island

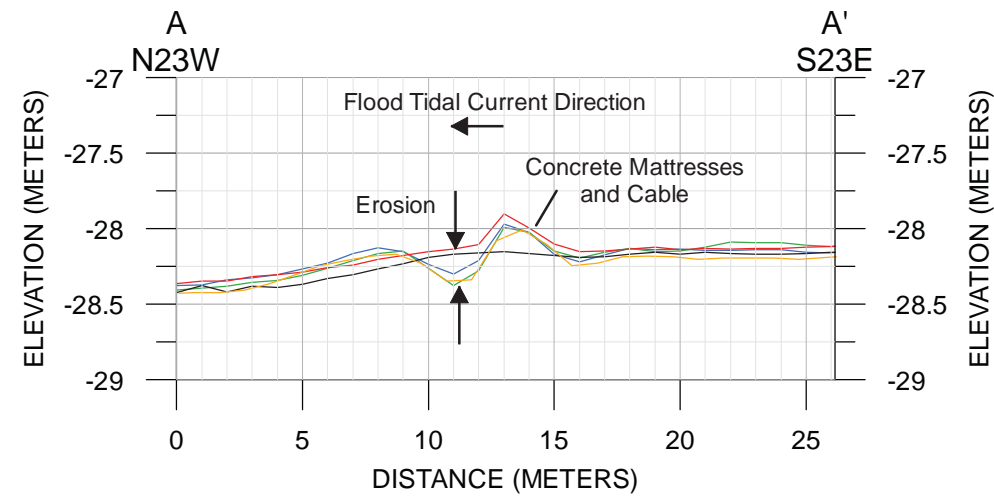

0.5 m
3 m
Vertical exaggeration is 6x.

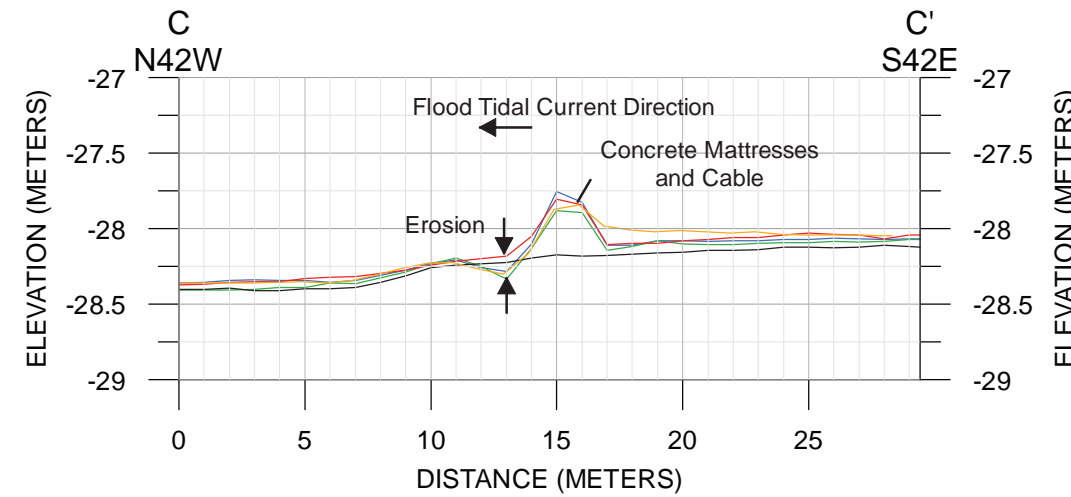

0.5 m
3 m
Vertical exaggeration is 6x.

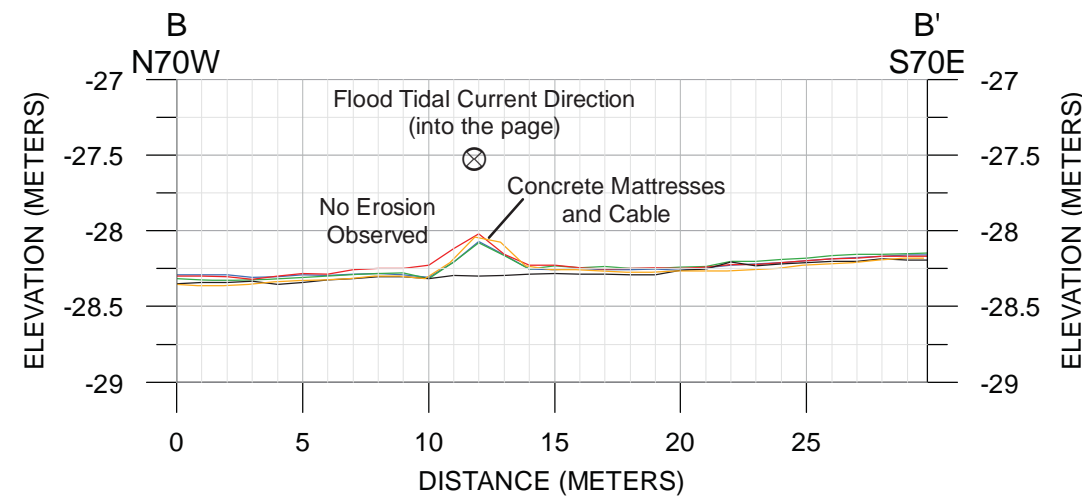

0.5 m
3 m
Vertical exaggeration is 6x.

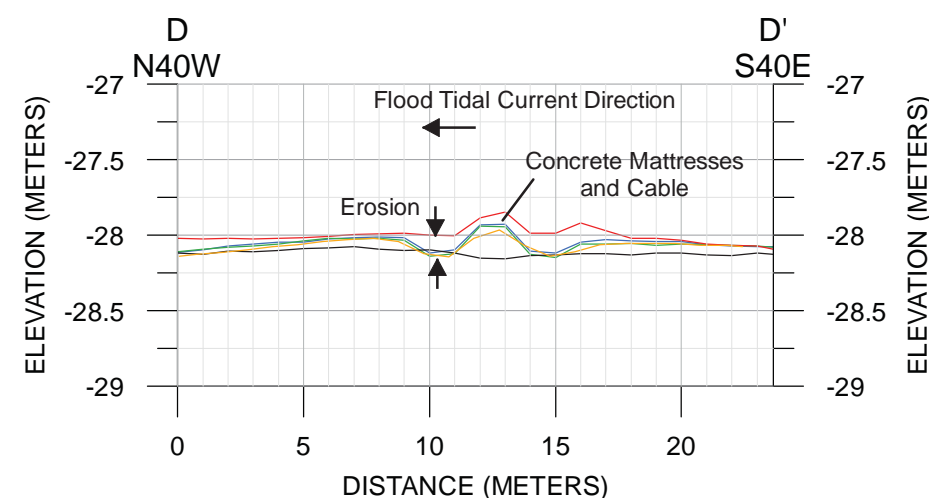

0.5 m
3 m
Vertical exaggeration is 6x.

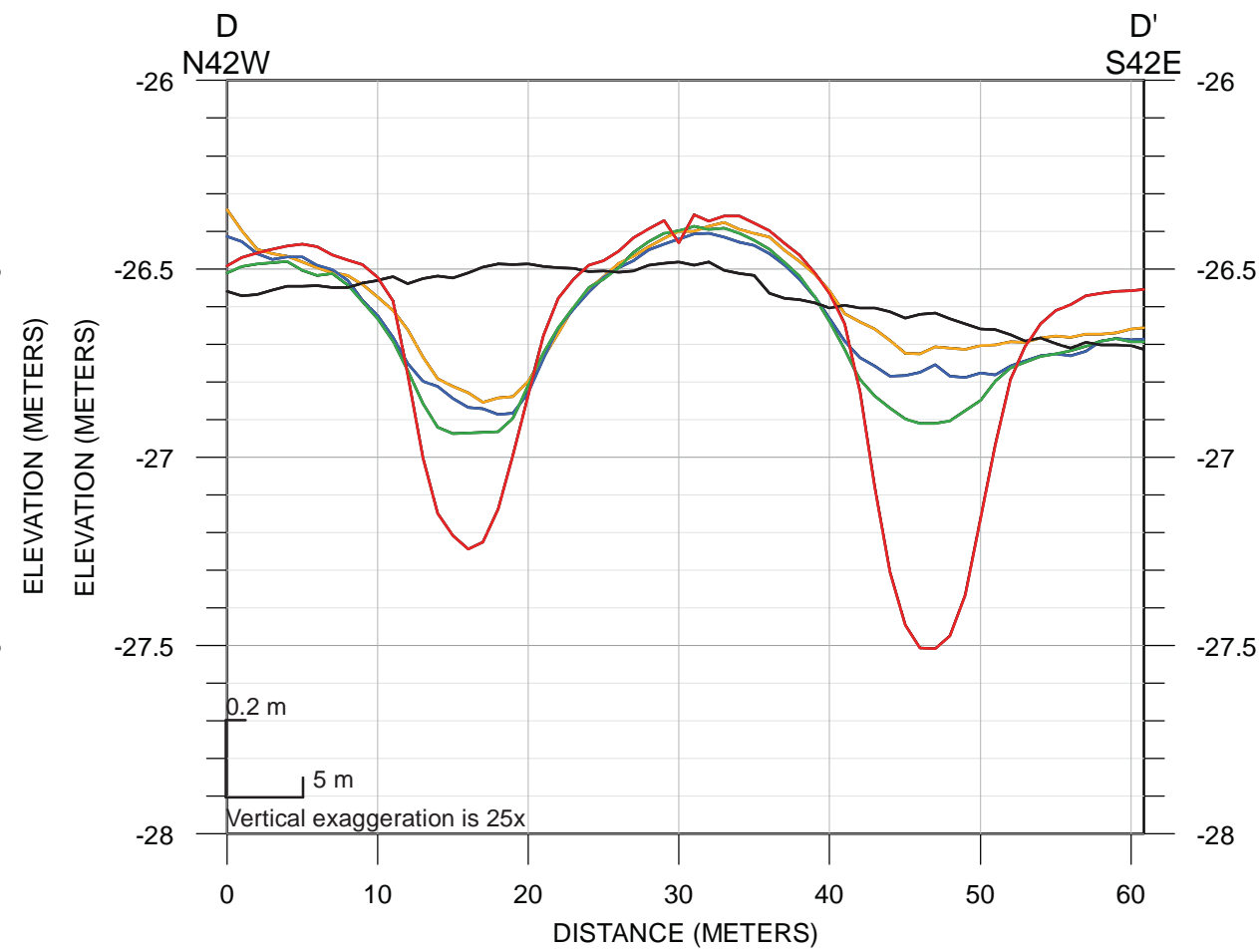
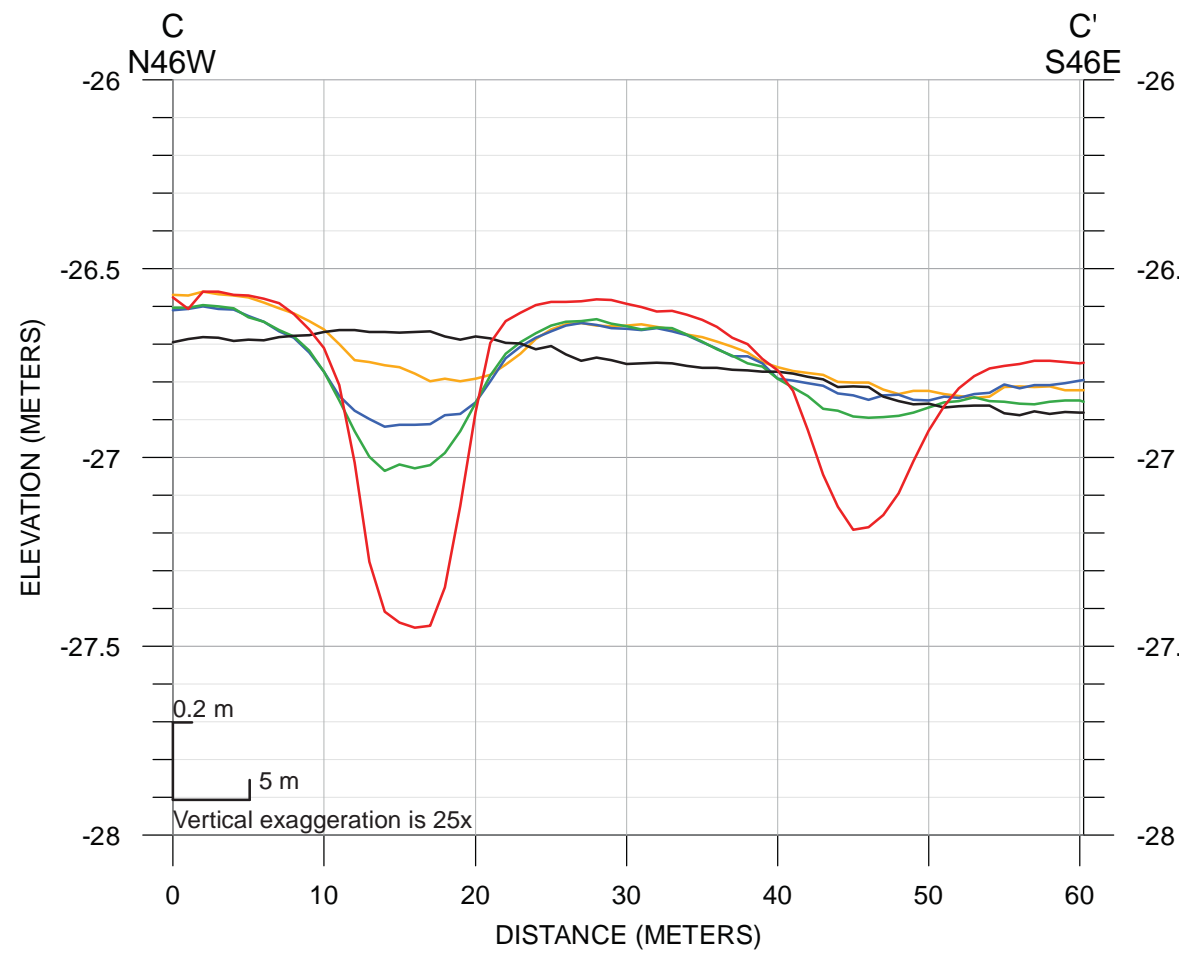

Legend

- Survey No. 1 (May 2016)
- Survey No. 2 (October 2016)
- Survey No. 3 (May 2017)
- Survey No. 4 (October 2017)
- Survey No. 5 (September 2018)

Profile Location Map

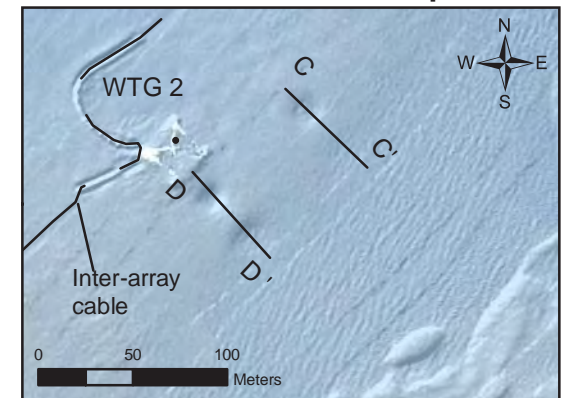

Notes:

The depressions shown in this figure were created by the L/B Brave Tern vessel while installing the wind turbine during Construction Season 2 that occurred in between Surveys 1 and 2. Bathymetry data shown in the plan views are from Survey 5.

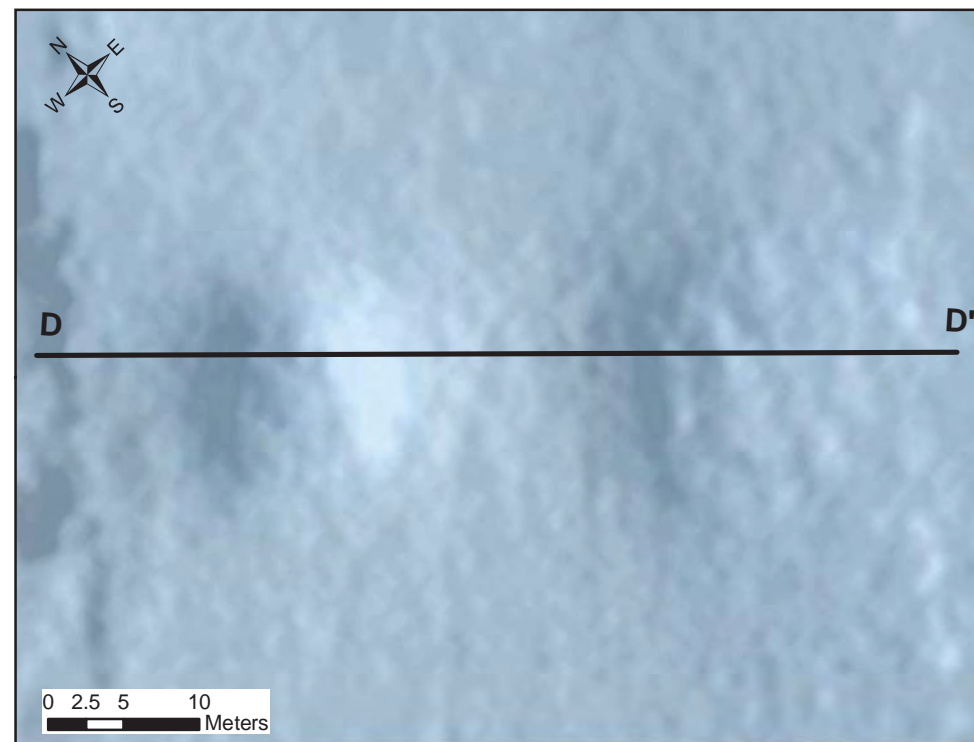
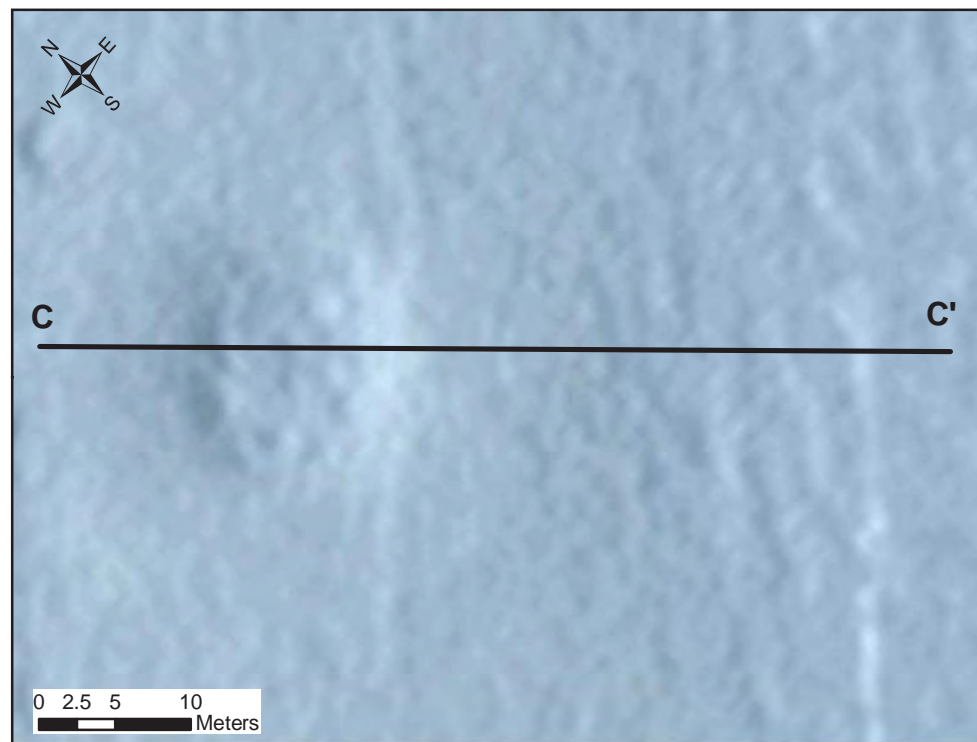

**EXAMPLE OF SEAFLOOR RECOVERY
WIND TURBINE GENERATOR NO. 2**
Seafloor Monitoring Study
Block Island Wind Farm and Transmission Project
Offshore Rhode Island

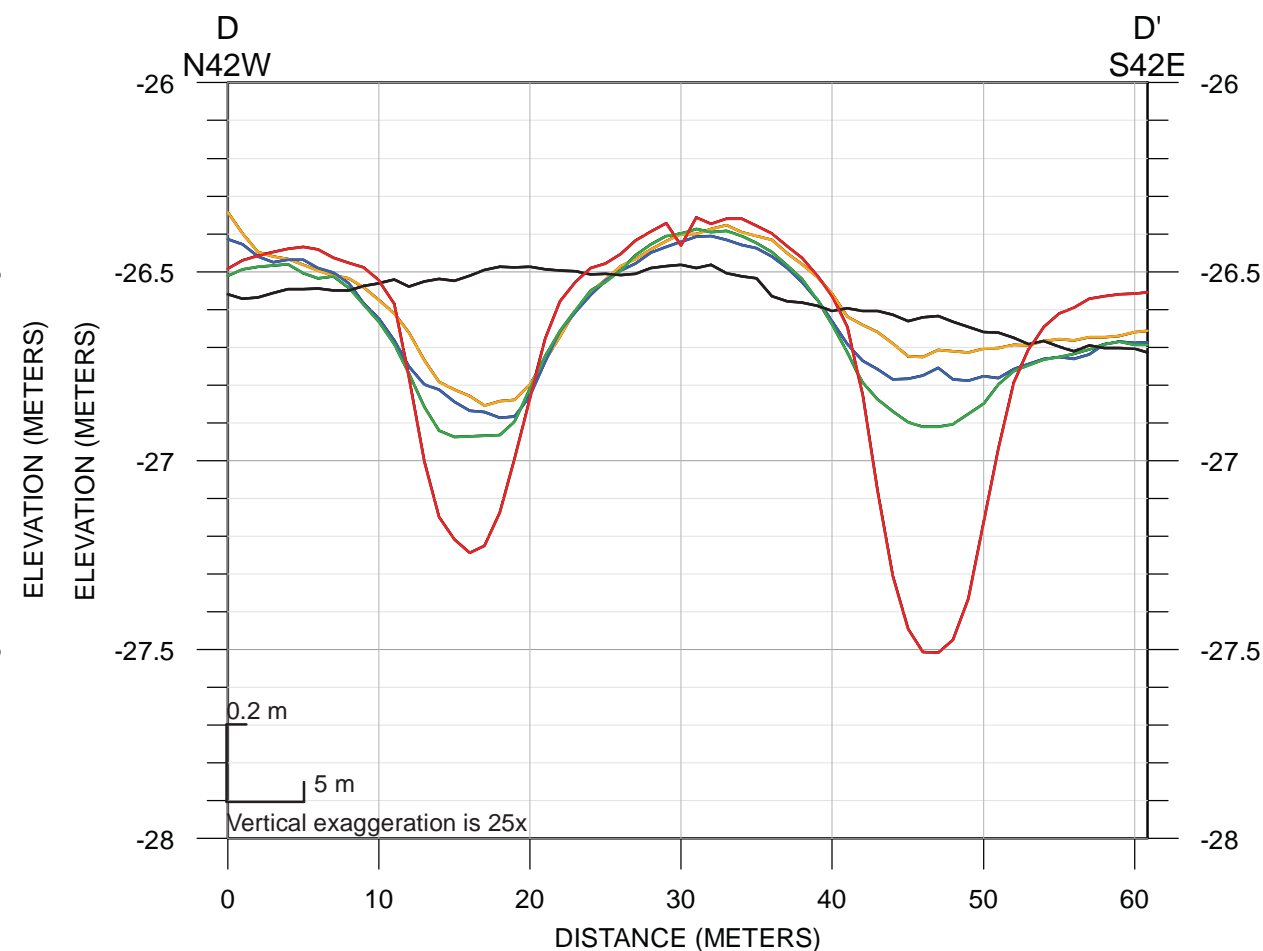
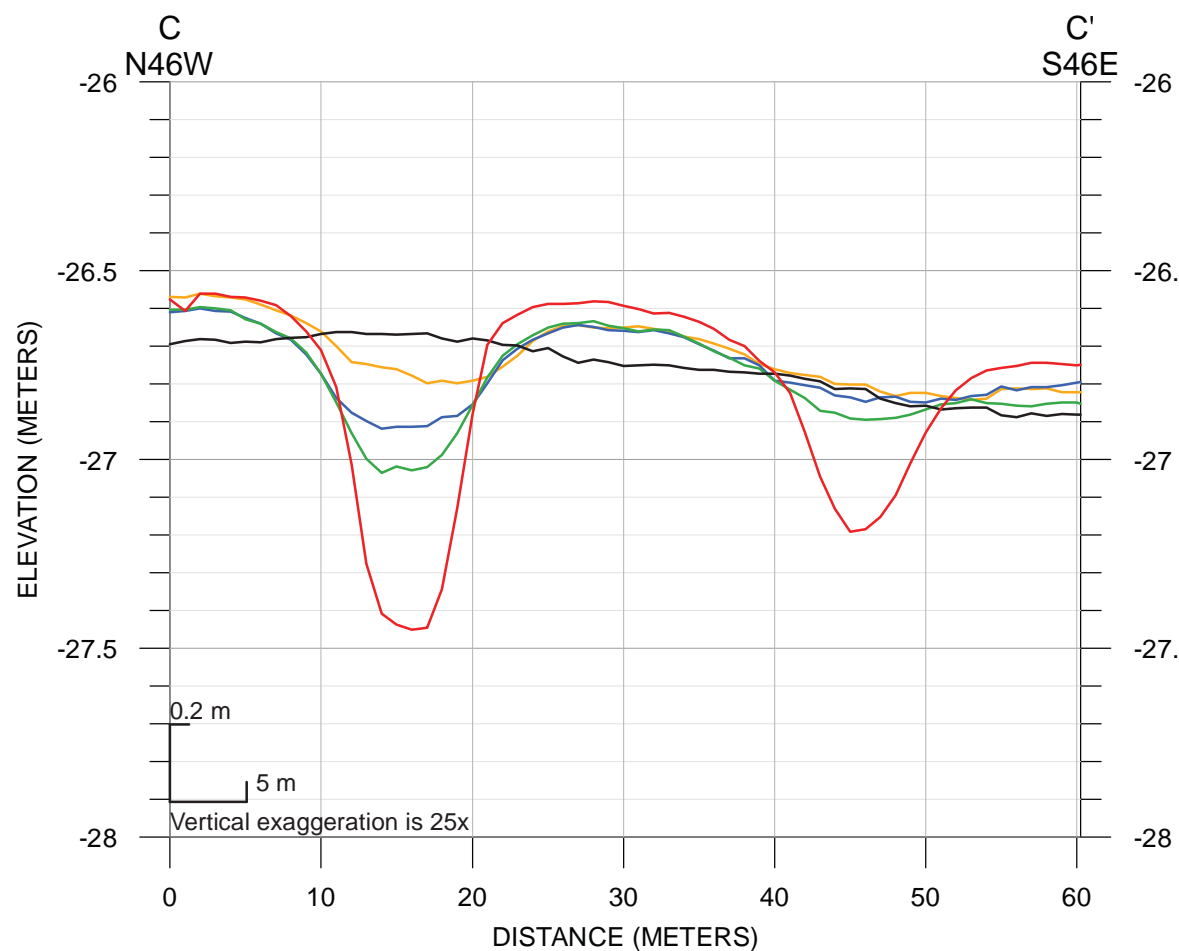

Legend

- Survey No. 1 (May 2016)
- Survey No. 2 (October 2016)
- Survey No. 3 (May 2017)
- Survey No. 4 (October 2017)
- Survey No. 5 (September 2018)

Profile Location Map

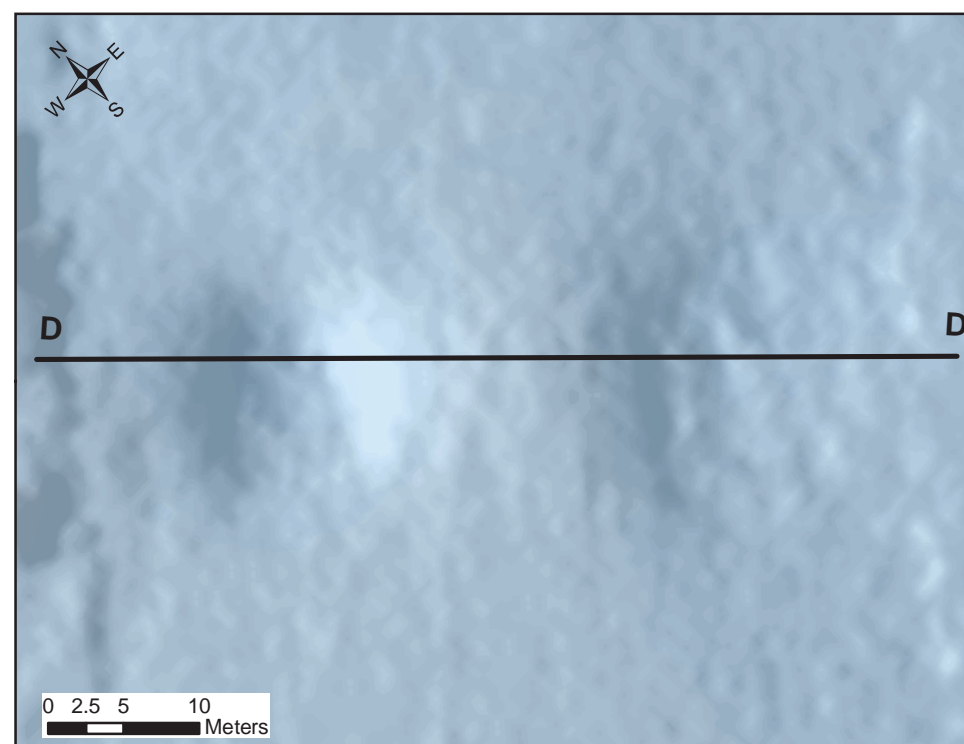
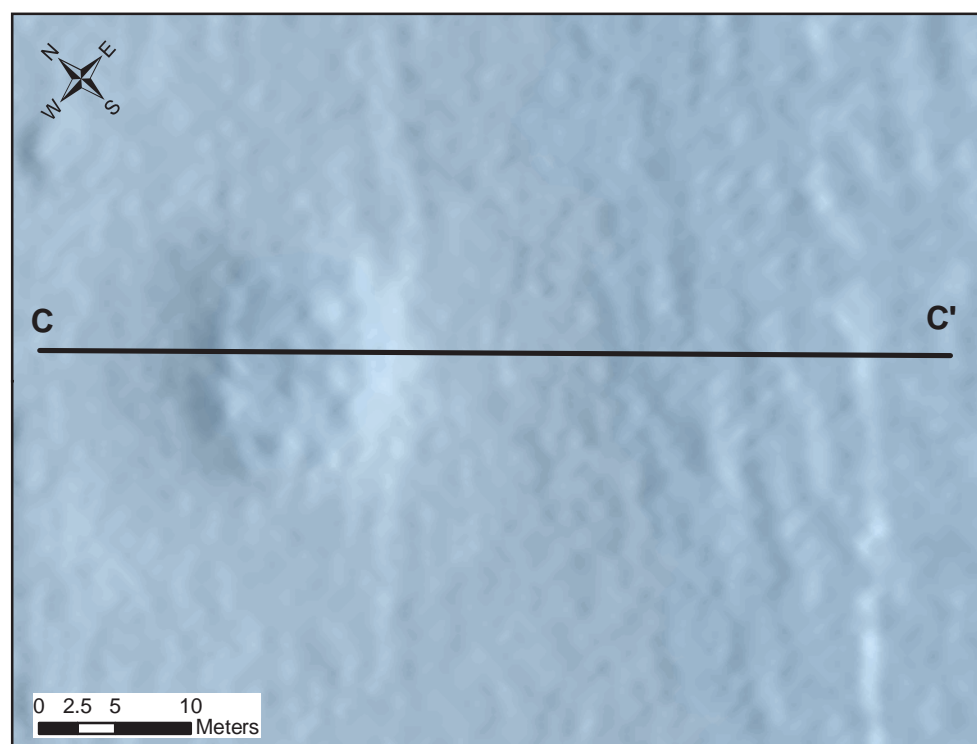
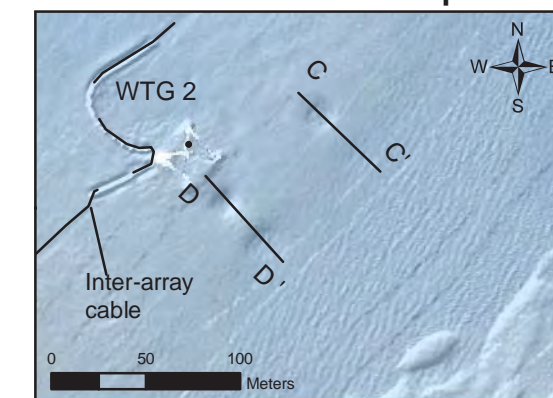

Notes:

The depressions shown in this figure were created by the L/B Brave Tern vessel while installing the wind turbine during Construction Season 2 that occurred in between Surveys 1 and 2. Bathymetry data shown in the plan views are from Survey 5.

**EXAMPLE OF SEAFLOOR RECOVERY
WIND TURBINE GENERATOR NO. 2**
Seafloor Monitoring Study
Block Island Wind Farm and Transmission Project
Offshore Rhode Island

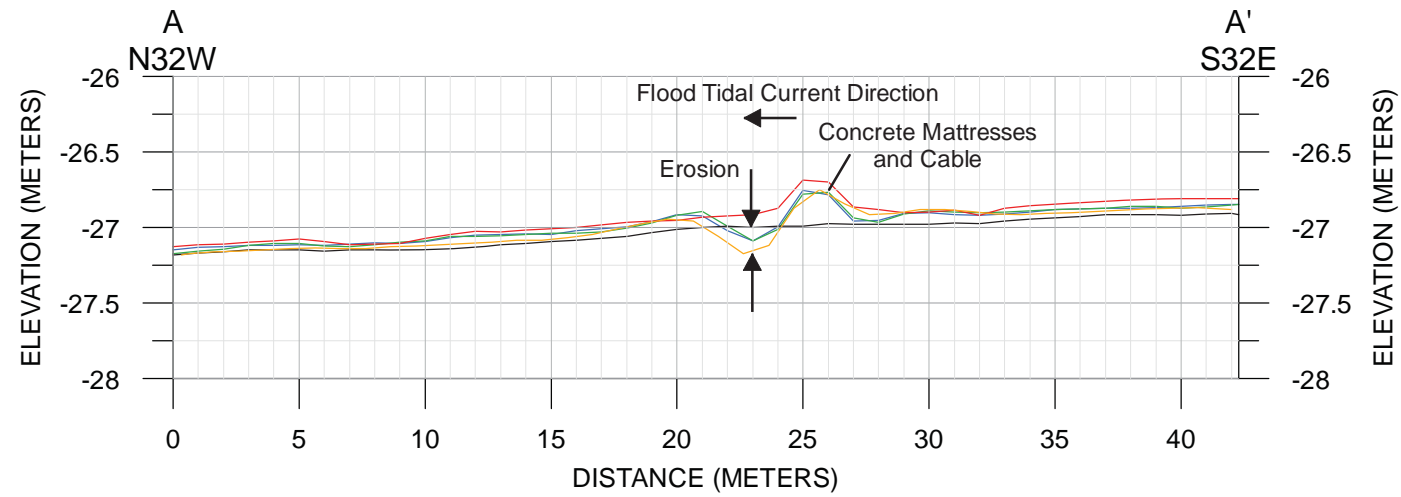

0.5 m
3 m
Vertical exaggeration is 6x.

Legend

- Survey No. 1 (May 2016)
- Survey No. 2 (October 2016)
- Survey No. 3 (May 2017)
- Survey No. 4 (October 2017)
- Survey No. 5 (September 2018)

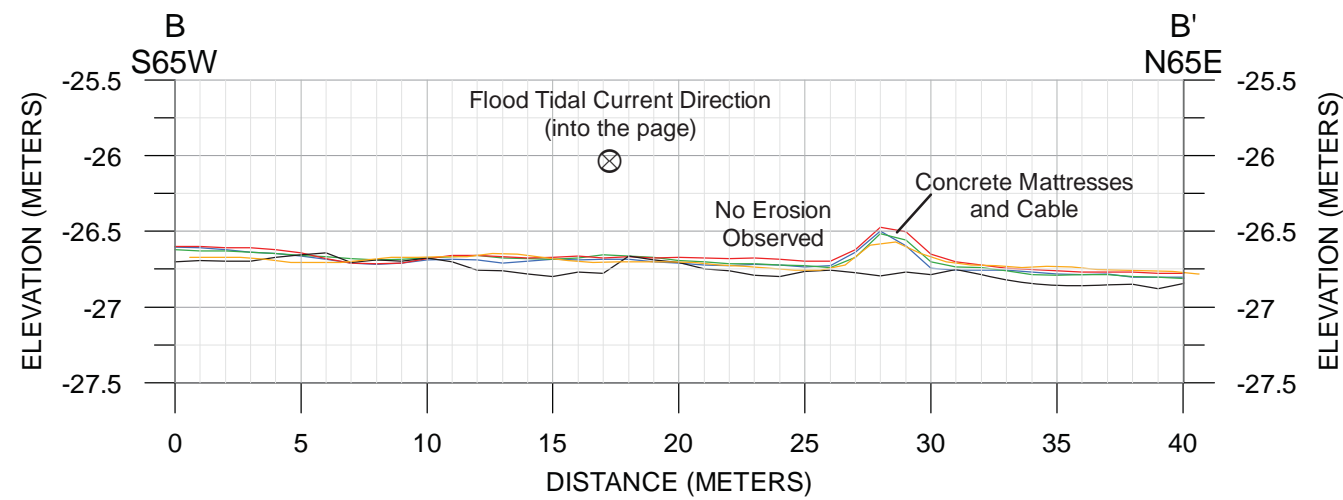

0.5 m
3 m
Vertical exaggeration is 6x.

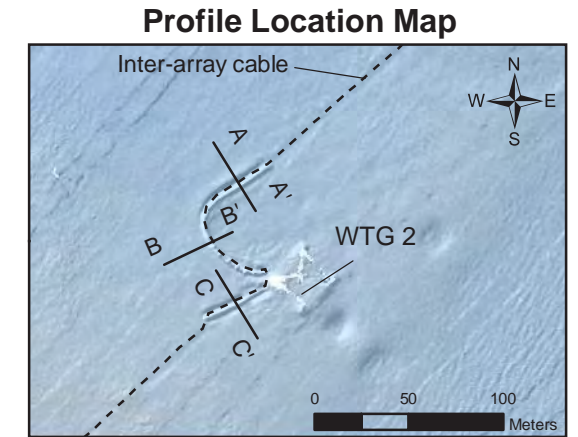

Notes:

Survey 1 was conducted before the cable and concrete mattresses were installed.

Principle tidal axis is aligned in the NNW-SSE direction. Cable segment in Profile B is nearly aligned with the principle tidal axis and shows the least amount of scour. Cable segments shown in Profiles A and D are oriented perpendicular to the principle tidal axis. Scour is most prevalent on the northern side of the cable/concrete mattresses which indicates the dominant tidal current flow at this location is likely to the NNW (flood tidal current direction).

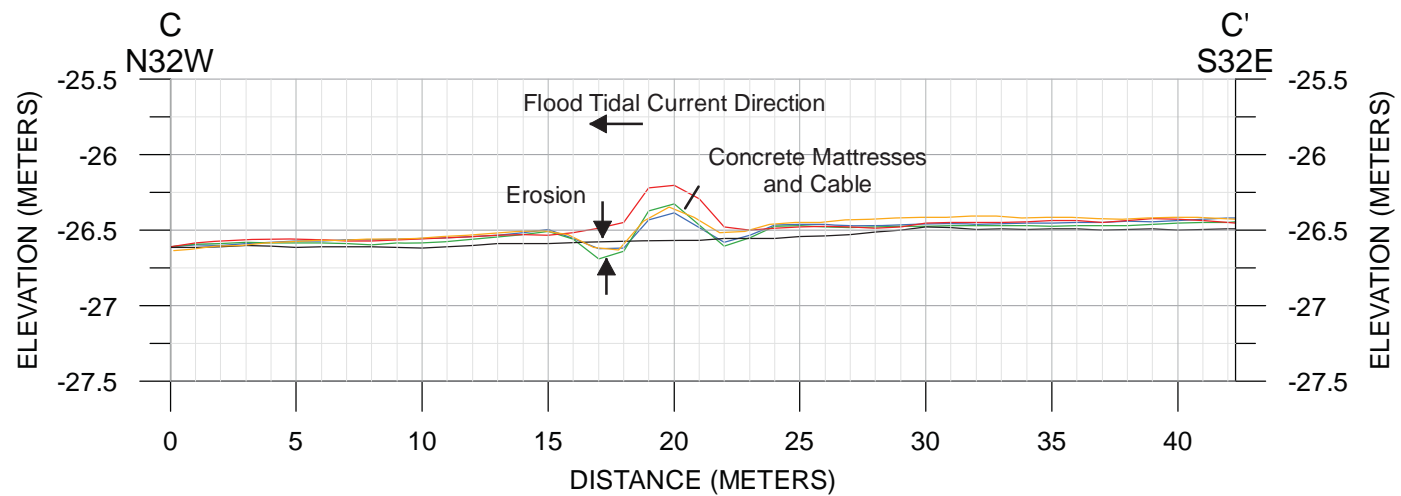

0.5 m
3 m
Vertical exaggeration is 6x.

**EXAMPLE OF SEAFLOOR RECOVERY
WIND TURBINE GENERATOR NO. 2**
Seafloor Monitoring Study
Block Island Wind Farm and Transmission Project
Offshore Rhode Island

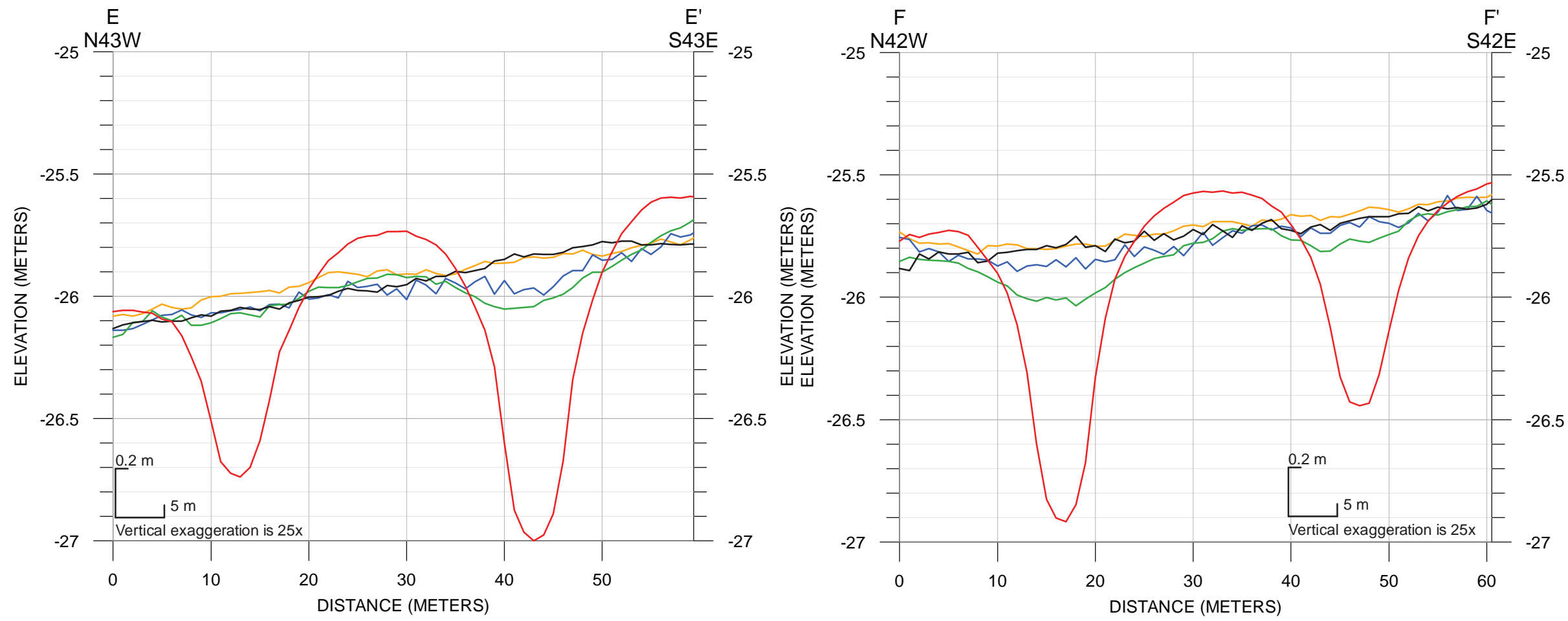

Legend

- Survey No. 1 (May 2016)
- Survey No. 2 (October 2016)
- Survey No. 3 (May 2017)
- Survey No. 4 (October 2017)
- Survey No. 5 (September 2018)

Profile Location Map

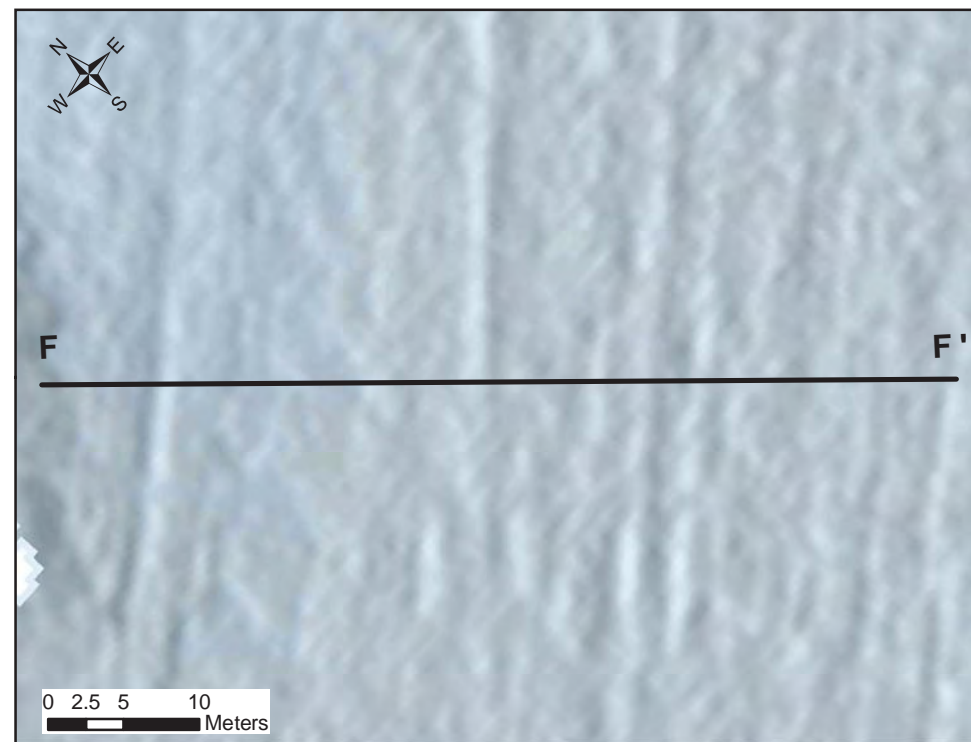
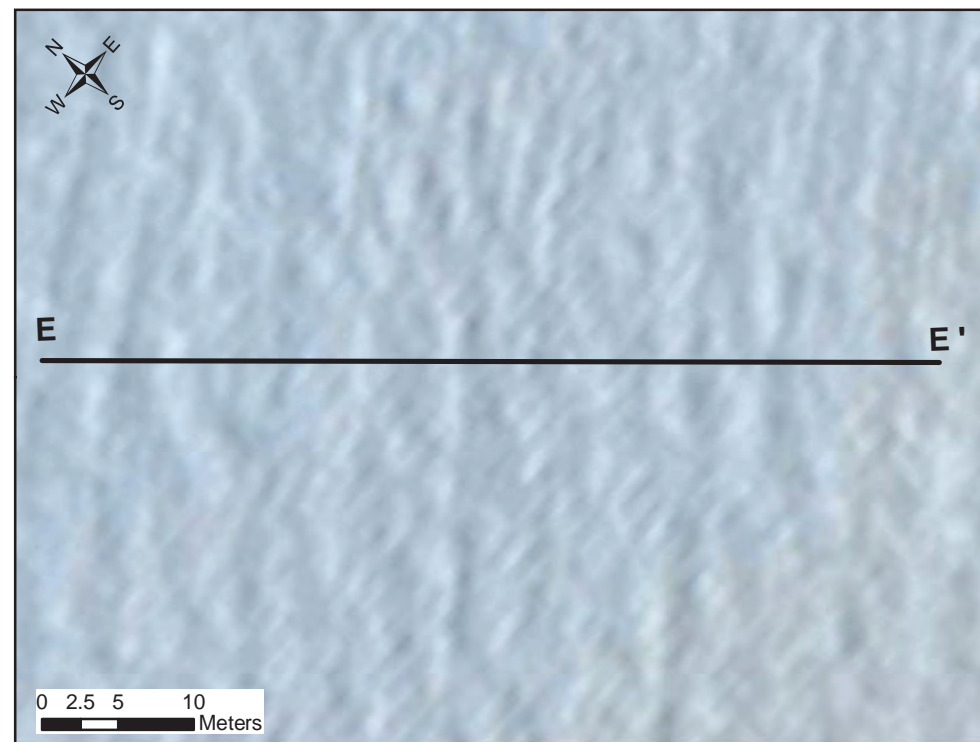
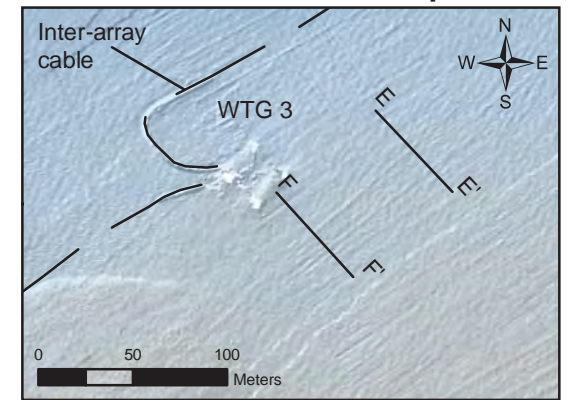

Notes:

The depressions shown in this figure were created by the L/B Brave Tern vessel while installing the wind turbine during Construction Season 2 that occurred in between Surveys 1 and 2. Bathymetry data shown in the plan views are from Survey 5.

**EXAMPLE OF SEAFLOOR RECOVERY
WIND TURBINE GENERATOR NO. 3**
Seafloor Monitoring Study
Block Island Wind Farm and Transmission Project
Offshore Rhode Island

N:\Projects\04_2015\04_8115_0001_BOEM_RODEO\BlockIsland_RI\Outputs\Post_Con_Survey_5\MXD\Fig-11_WTG3_Spud_Depression_Profiles.mxd, 1/11/2019, T.Weathers

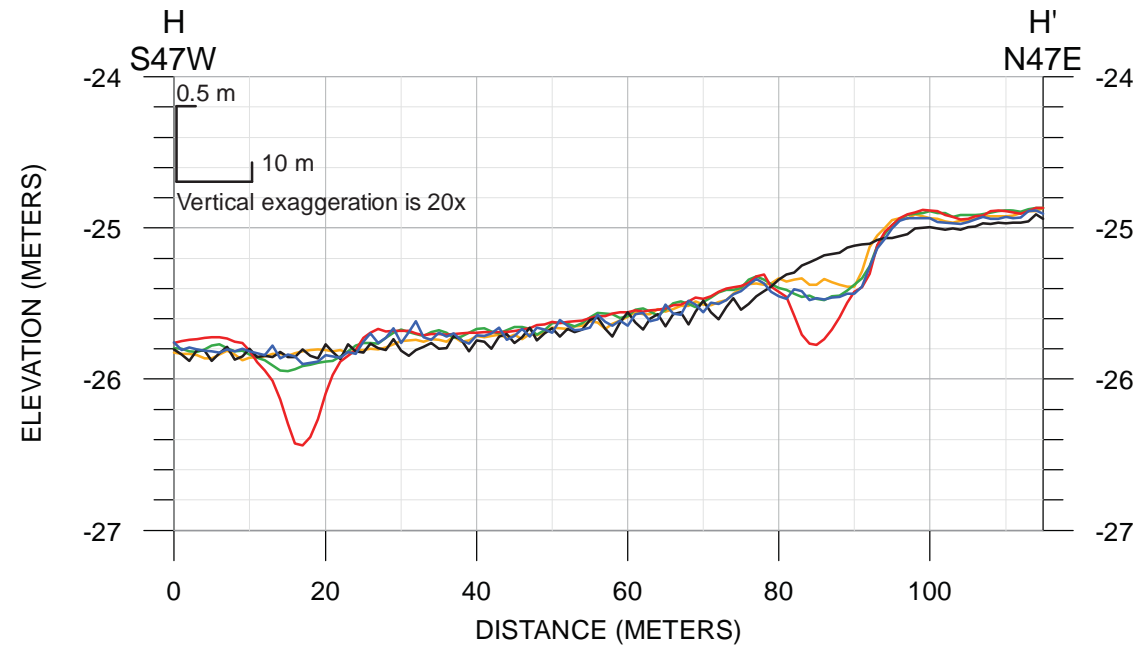
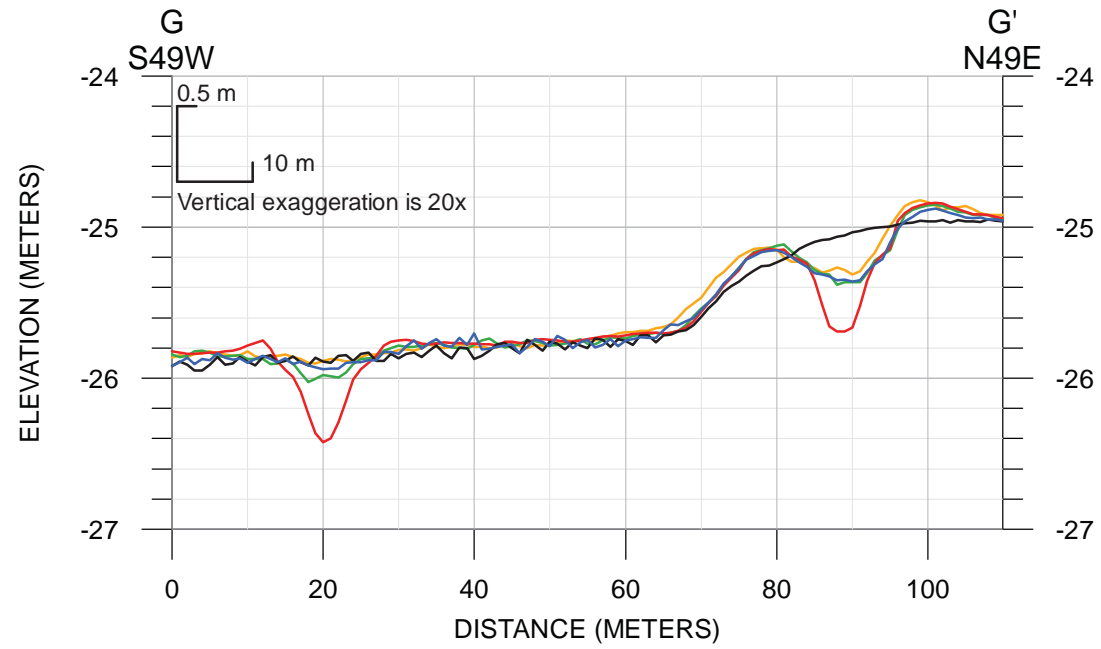

Legend

- Survey No. 1 (May 2016)
- Survey No. 2 (October 2016)
- Survey No. 3 (May 2017)
- Survey No. 4 (October 2017)
- Survey No. 5 (September 2018)

Profile Location Map

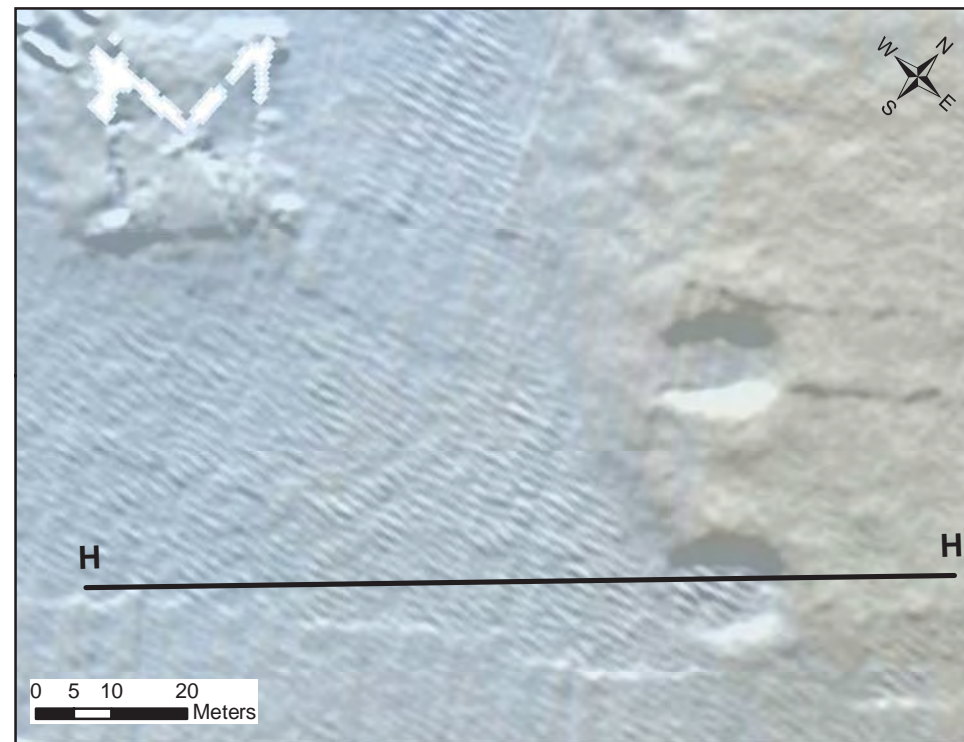
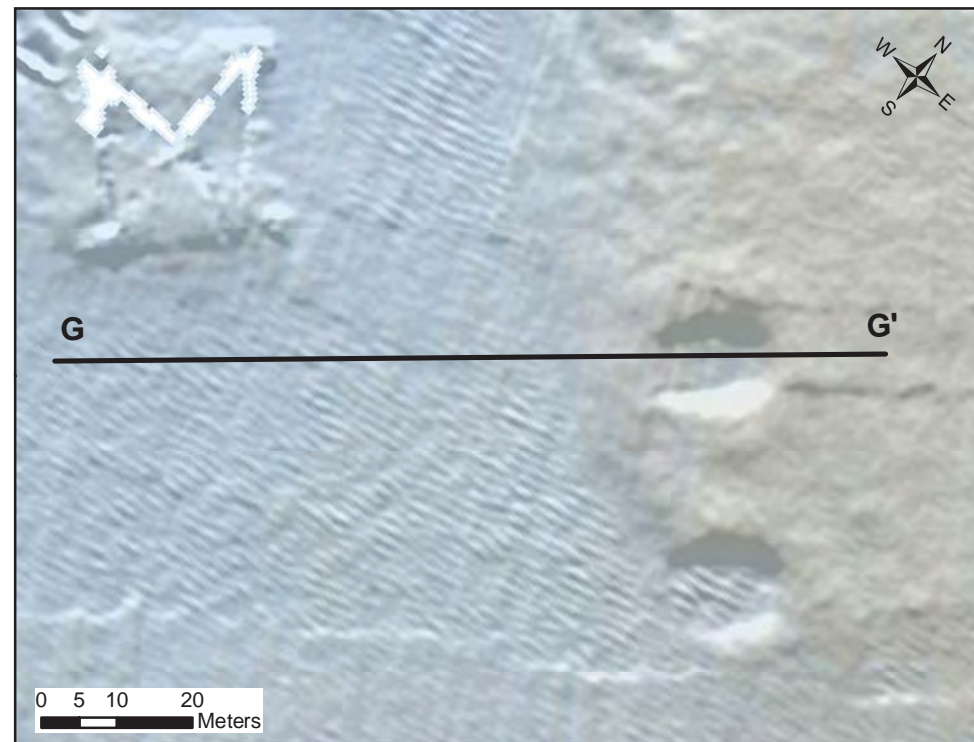
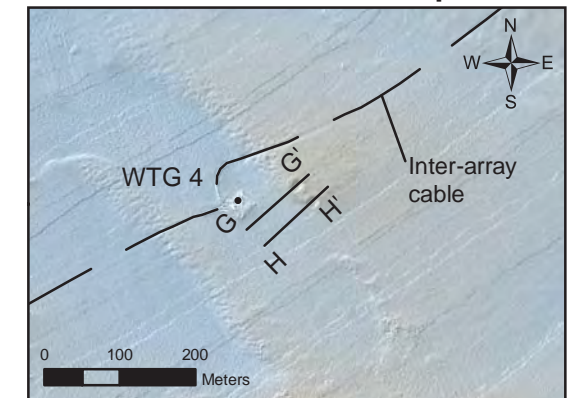

Notes:

The depressions shown in this figure were created by the L/B Brave Tern vessel while installing the wind turbine during Construction Season 2 that occurred in between Surveys 1 and 2. Bathymetry data shown in the plan views are from Survey 5.

**EXAMPLE OF SEAFLOOR RECOVERY
WIND TURBINE GENERATOR NO. 4**
Seafloor Monitoring Study
Block Island Wind Farm and Transmission Project
Offshore Rhode Island

N:\Projects\04_2015\04_8115_0001_BOEM_RODEO\BlockIsland_R1\Output\Post_Con_Survey_5\MXD\Fig-12_WTG4_Spud_Depression_Profiles.mxd, 1/11/2019, T. Weathers

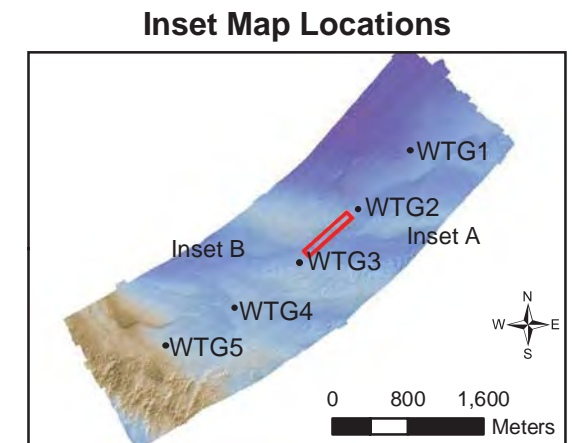
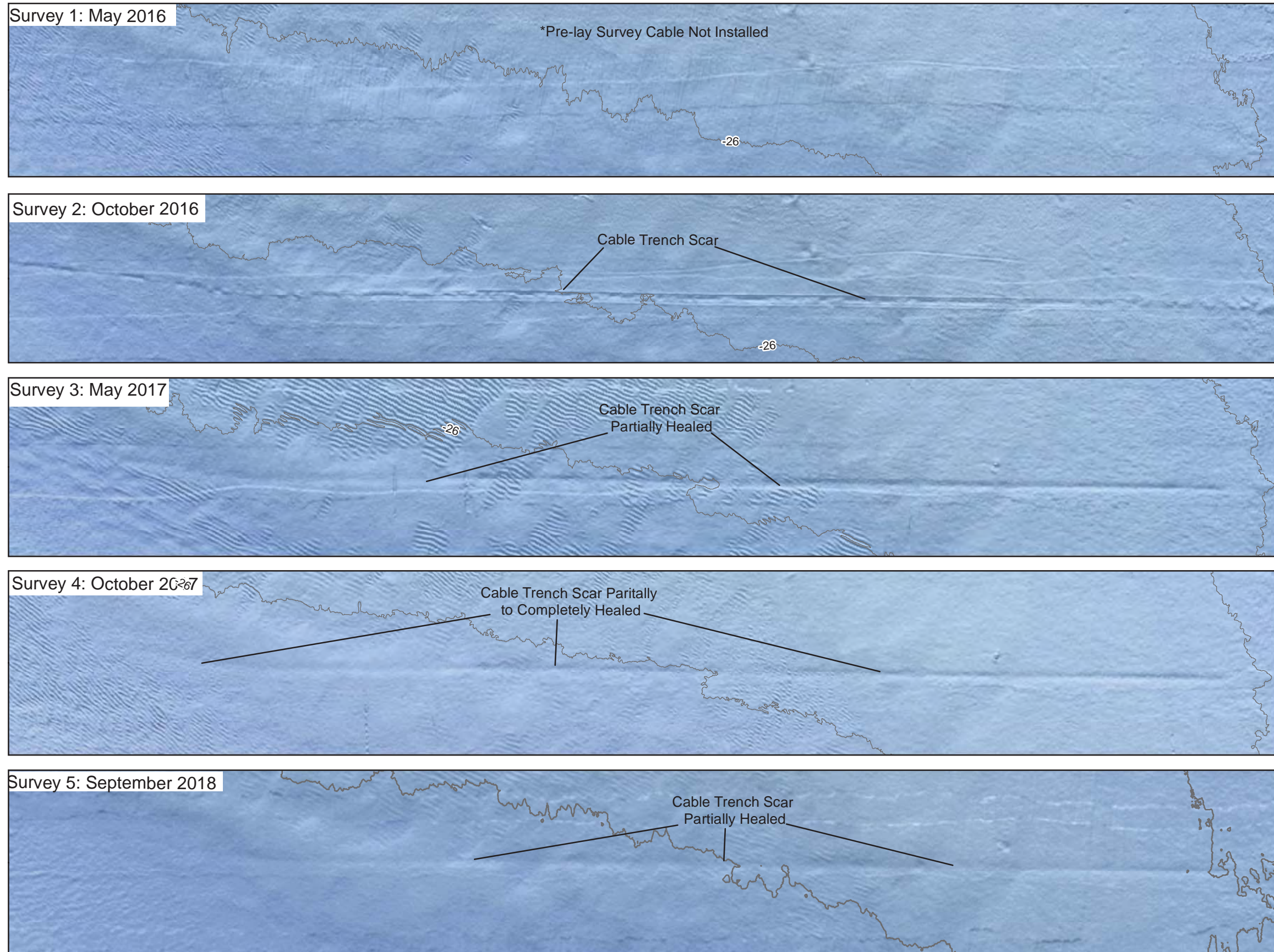

Notes:

The comparison of the inter-array cable from the four surveys (May 2016 through October 2017), indicate that cable trench scar has partially healed. The inter-array cable was installed between June and July 2016, and Survey 2 (Oct. 2016) showed that the trench scar was up to approximately 10 cm in depth in this area. Survey 3 (May 2017) showed in this same area that portions of the cable trench had completely healed while other areas were up to 7 cm deep. Survey 4 (Oct. 2017) showed that most of the cable trench in this extent had healed, with a few areas up to approximately 5 cm in depth.

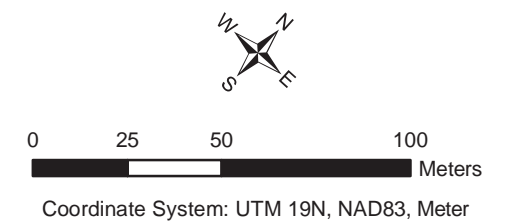

**INTER-ARRAY CABLE TRENCH
MAY 2016 THROUGH SEPTEMBER 2018 SURVEYS**
Seafloor Monitoring Study
Block Island Wind Farm and Transmission Project
Offshore Rhode Island

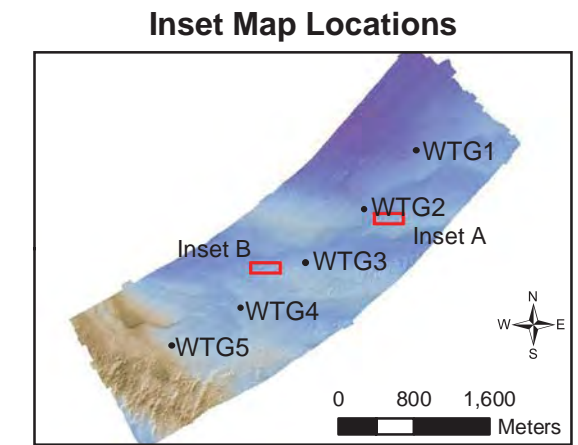
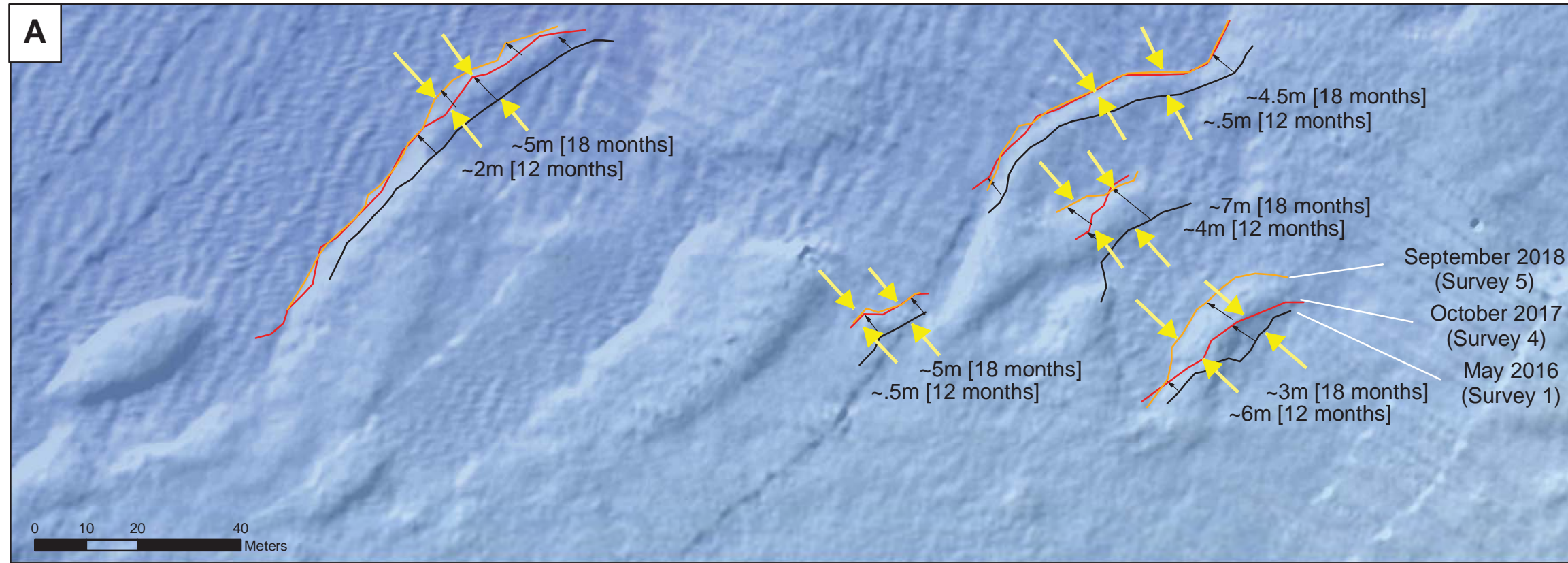

Notes:

The comparison of bedform features from the two surveys (October 2017 and September 2018) conducted over one year apart, indicate that the bedforms have shifted approximately 2 to 6 meters to the northwest compared to the previous comparison of 3 to 9 meters from May 2016 and October 2017. The orange, red, and black lines represent the interpreted features from the September 2018, October 2017, and May 2016 surveys, respectively.

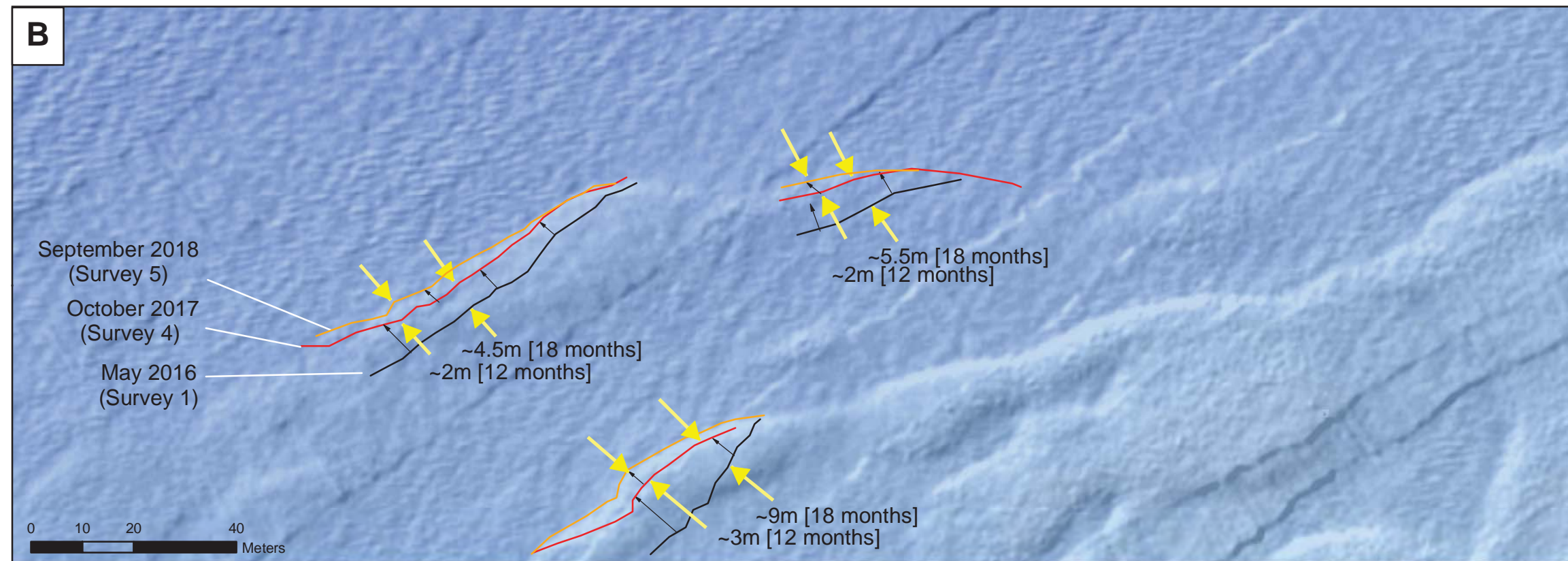

Coordinate System: UTM 19N, NAD83, Meter

BEDFORM CHANGES REVEALED BY OCTOBER 2017 AND SEPTEMBER 2018 SURVEYS
Seafloor Monitoring Study
Block Island Wind Farm and Transmission Project
Offshore Rhode Island

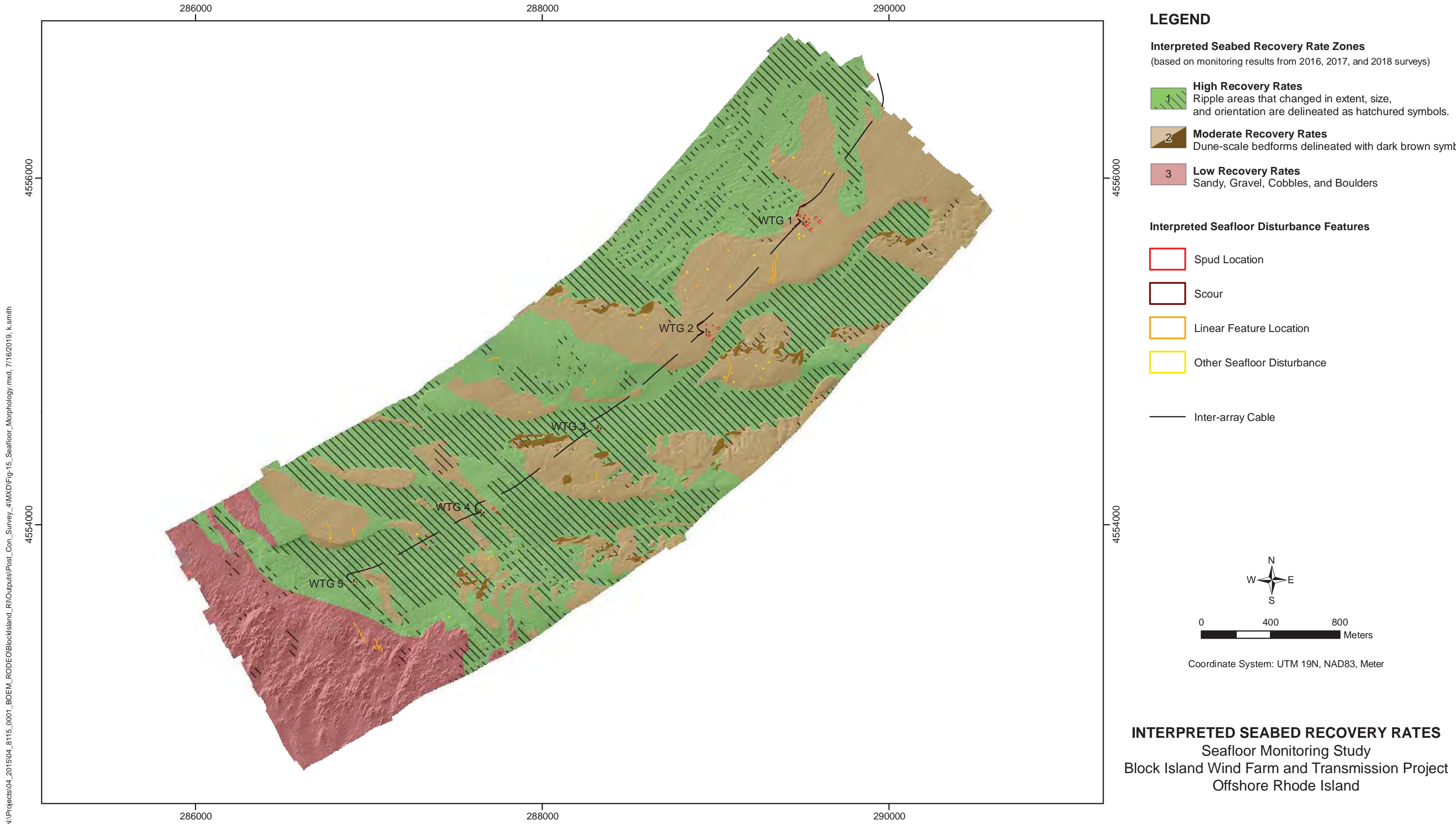

N:\Projects\04_2015\04_8115_0001_BOEM_RODEO\BlockIsland_R1\Output\Post_Con_Survey_4\AMXD\Fig-15_Seafloor_Morphology.mxd, 7/16/2019, k.smith

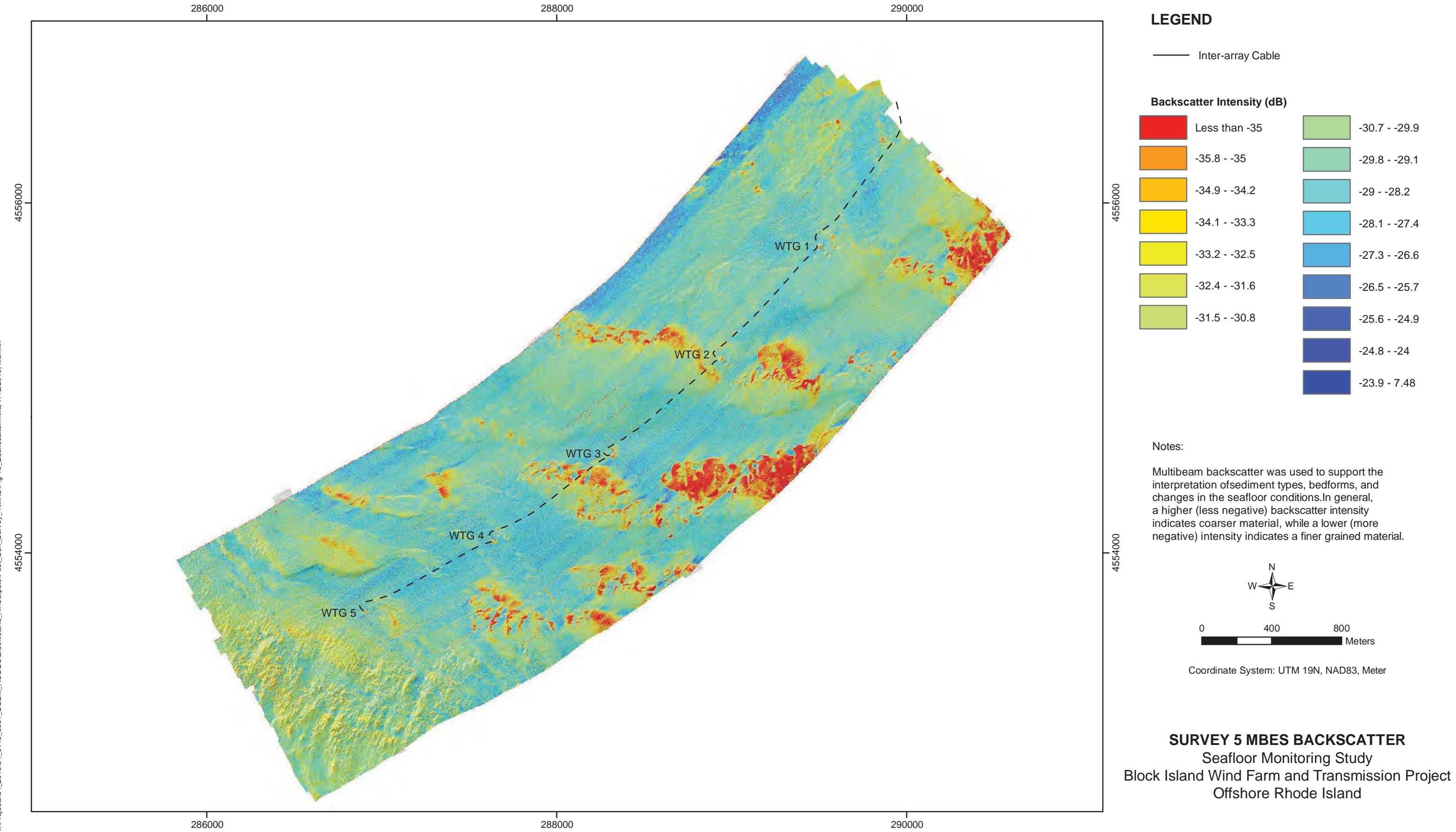

N:\Projects\04_2015\04_8115_0001_BOEM_BLOCKISLAND_R1\Output\Post_Con_Survey_4\MXD\Fig-16_Backscatter.mxd, 7/12/2019, k.smith

CHARTS

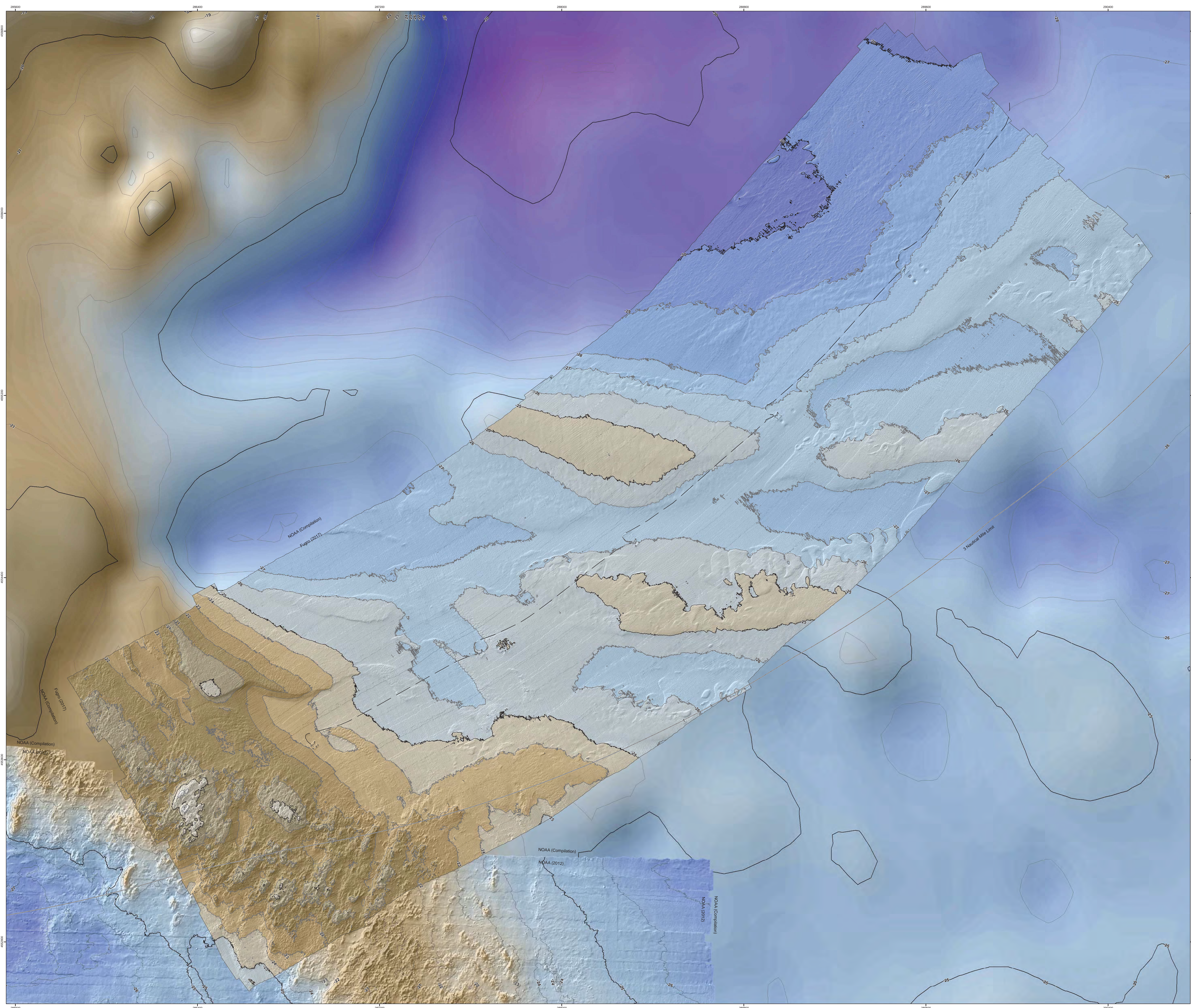

LEGEND

- - - Export Cable/Inner Array Cable
- 3 Nautical Mile Limit

Bathymetry (Meters, MLLW)

-18.9 - -18	-26.9 - -26
-19.9 - -19	-27.9 - -27
-20.9 - -20	-28.9 - -28
-21.9 - -21	-29.9 - -29
-22.9 - -22	-30.9 - -30
-23.9 - -23	-31.9 - -31
-24.9 - -24	-32.9 - -32
-25.9 - -25	-33.2 - -33

- Major Contour is 5 meters
- Minor Contour is 1 meter

- Notes:**
- Fugro marine survey data were collected on September 28 and 30, 2018 onboard the R/V Westley using a high-resolution integrated multibeam bathymetric survey system.
 - Differential Global Positioning System (DGPS) corrections were obtained from Fugro's ChirStar GNSS in real-time via a G2 subscription.
 - Survey equipment utilized for data collection included the following systems:
 - Hacon Seafloor 7120 S12 Multibeam Echo-sounder (MBES)
 - Applan POS MV 320 (4) Motion Reference Unit & Positioning System
 - Applied Microplane Limited (AML) SmartPhoto for Sound Velocity Profiles
 - PPS WinFog (3.10.48) navigation and data acquisition software
 - NOAA (2012) Multibeam bathymetric data is from the National Oceanic and Atmospheric Administration's (NOAA) hydrographic survey of Block Island Sound, New York. This survey was conducted August 25 through August 28, 2012.
 - NOAA Complete Bathymetric data is a compilation of NOAA sounding files in the area that were collected between 1938 to 1979.

This document may only be used for the purposes for which it was commissioned and in accordance with the terms of engagement for that commission. Unauthorized use of this document in any form whatsoever is prohibited. Not for navigational use.

GEODETTIC INFORMATION

SPHEROID:	GRS 1980
SEMI-MAJOR AXIS:	6,378,137.0000
SEMI-MINOR AXIS:	6,356,752.3141
FLATTENING:	298.257222101
ECCENTRICITY ² :	0.00680348
PROJECTION:	UNIVERSAL TRANSVERSE MERCATOR
ZONE:	ZONE 18 NORTH
LONGITUDE OF ORIGIN:	76.000
FALSE EASTING:	500,000
FALSE NORTHING:	0

+ Coordinate Grid is UTM Zone 18N
+ NAD 1983, Meters

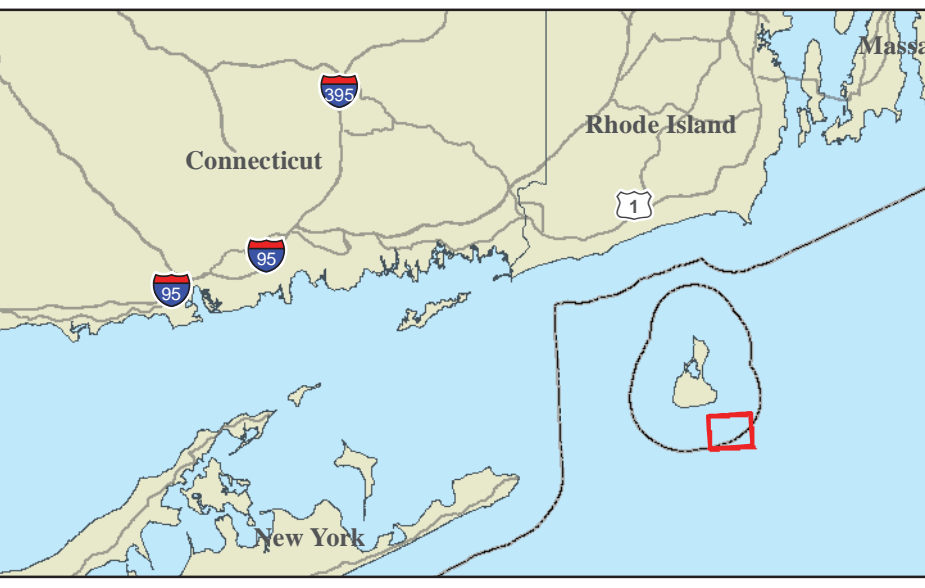

FUGRO FUGRO MARINE GEOSERVICES, INC.
 World Trade Center, Suite 350
 101 Water Main Street
 Norfolk, Virginia 23510
 Tel: (757) 625-3362
 Fax: (757) 625-3362
 www.fugro.com

SURVEY 5 (SEPTEMBER 2018) BATHYMETRY
Seafloor Monitoring Study
Block Island Wind Farm and Transmission Project
Offshore Rhode Island

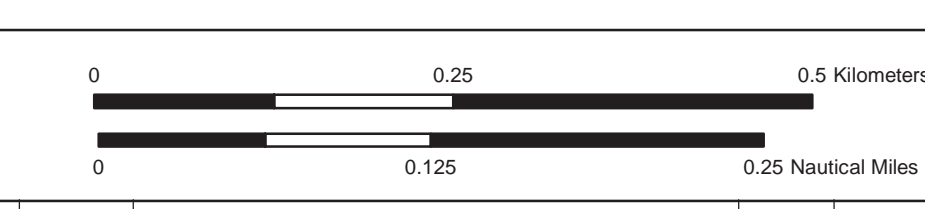

NO.	DATE	DESCRIPTION	DRAWN	CHKD	APPR
1	Dec 2018	Survey 5 (Dec. 2018) Report	TAW	WBC	KRS
2					
3					

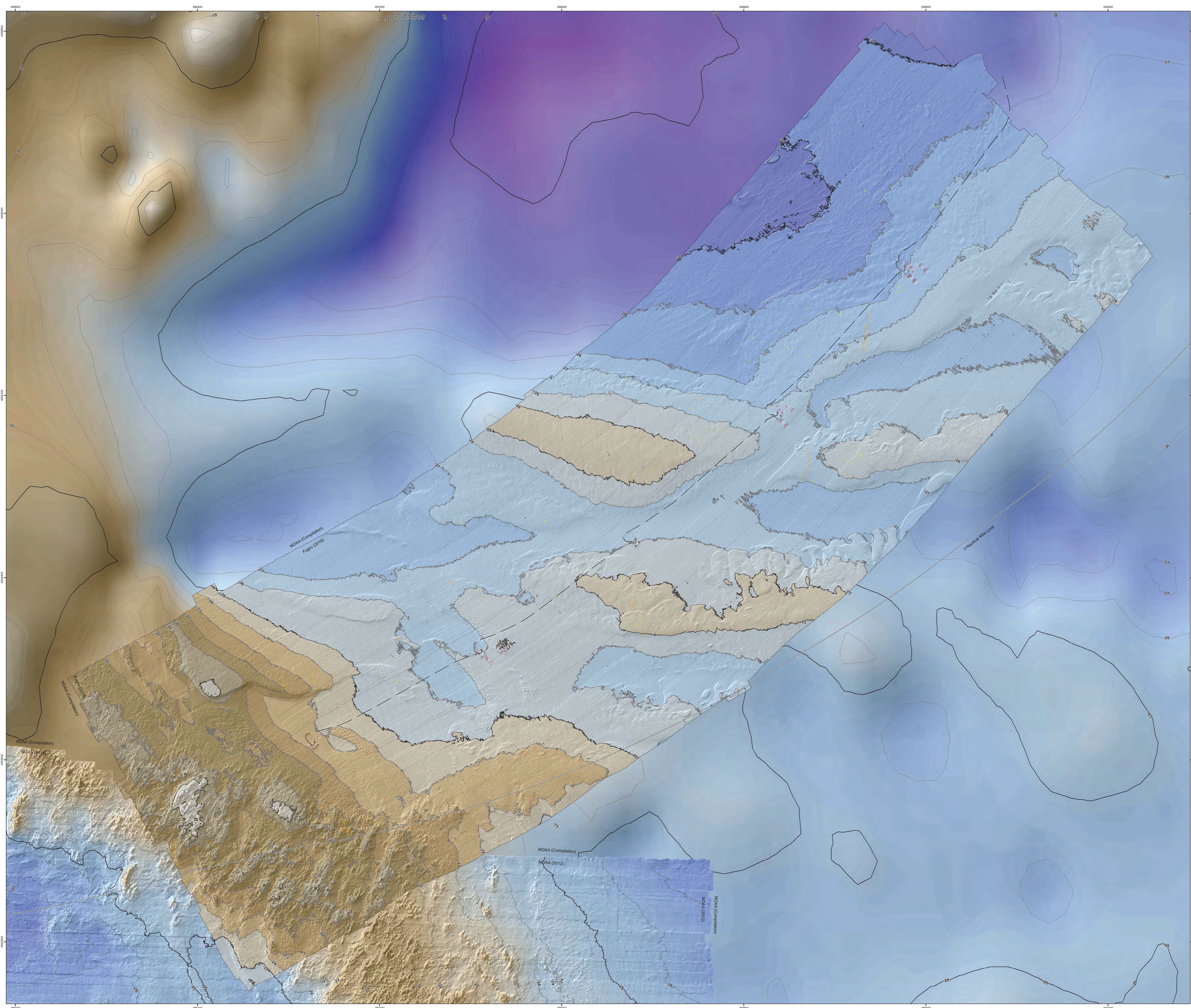

LEGEND

- Export Cable/Inner Array Cable
- 3 Nautical Mile Limit

Bathymetry (Meters, MLLW)

-18.0 - -18	-26.9 - -26
-19.0 - -19	-27.9 - -27
-20.0 - -20	-28.9 - -28
-21.0 - -21	-29.9 - -29
-22.0 - -22	-30.9 - -30
-23.0 - -23	-31.9 - -31
-24.0 - -24	-32.9 - -32
-25.0 - -25	-33.2 - -33

- Major Contour is 5 meters
- Minor Contour is 1 meter

Interpreted Seafloor Disturbance Features

- Spud Location
- Scour
- Linear Feature
- Other Seafloor Disturbance

Notes:

- Fugro marine survey data were collected on September 28 and 30, 2018 onboard the R/V Westley using a high-resolution integrated multibeam bathymetric survey system.
- Differential Global Positioning System (DGPS) corrections were obtained from Fugro's ChirixStar GNSS in real-time via a G2 subscription.
- Survey equipment utilized for data collection included the following systems:
 - Hacon Seabeck 7120 S12 Multibeam Echo-sounder (MBES)
 - Applan POS MV 320 (4-B Motion Reference Unit & Positioning System)
 - Applied Microplane Limited (AML) SonarPro for Sound Velocity Profiles
 - PPS Wefing (3, 10.4) navigation and data acquisition software
- NOAA (2012) Multibeam bathymetric data is from the National Oceanic and Atmospheric Administration's (NOAA) hydrographic survey of Block Island Sound, New York. This survey was conducted August 25 through August 28, 2012.
- NOAA Compiled Bathymetric data is a compilation of NOAA sounding files in the area that were collected between 1938 to 1979.

This document may only be used for the purposes for which it was commissioned and in accordance with the terms of engagement for that commission. Unauthorized use of this document in any form whatsoever is prohibited and is illegal under applicable law.

GEODETTIC INFORMATION

SPHEROID: GRS 1980
 SEMI-MAJOR AXIS: 6,378,137.0000
 SEMI-MINOR AXIS: 6,356,752.3141
 MEAN FLATTENING: 298.2572149
 ECCENTRICITY: 0.0083676
 PROJECTION: UNIVERSAL TRANSVERSE MERCATOR
 ZONE: 18 NORTH
 FALSE EASTING: 500,000
 FALSE NORTHING: 0
 Coordinate Grid is UTM Zone 18N, NAD 1983, Meters

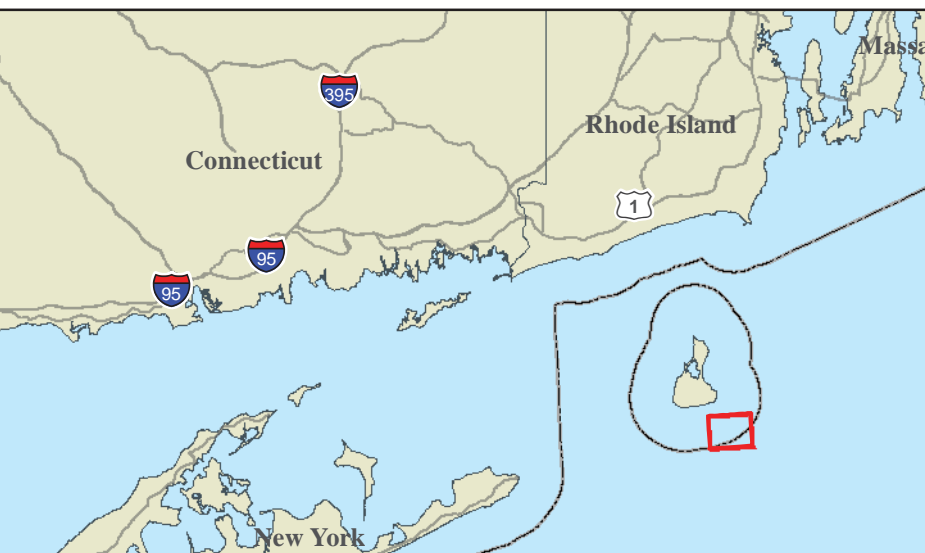

FUGRO FUGRO MARINE GEOSERVICES, INC.
 World Trade Center, Suite 350
 101 Water Main Street
 Norfolk, Virginia 23510
 Tel: (757) 625-3352
 Fax: (757) 625-3352
 www.fugro.com

INTERPRETED SEAFLOOR DISTURBANCE FEATURES FROM SURVEY 5 (SEP. 2018)
 Seafloor Monitoring Study
 Block Island Wind Farm and Transmission Project
 Offshore Rhode Island

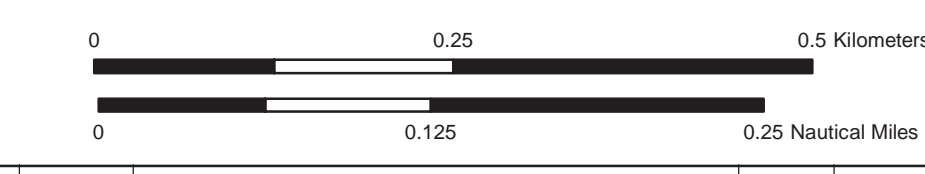

NO.	DATE	DESCRIPTION	DRAWN	CHKD	APPR
1	Dec. 2018	Survey 5 (Sep. 2018) Report	TAW	WBC	KRS
2					
3					

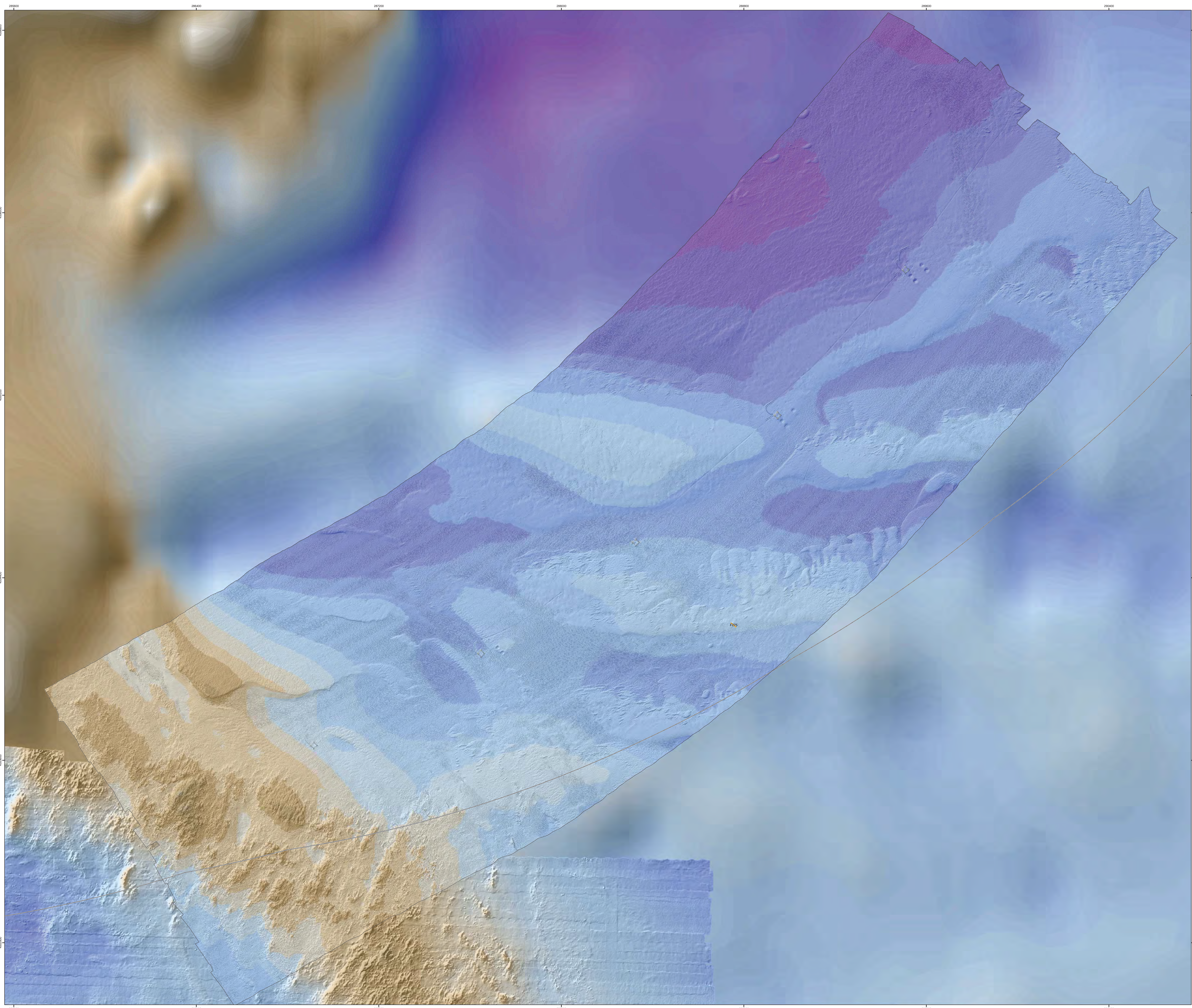

LEGEND

- - - Export Cable/Inter Array Cable
 - 3 Nautical Mile Limit
- Bathymetry (Meters, MLLW)**
- | | |
|--------------|--------------|
| -16.9 to -16 | -24.9 to -24 |
| -17.9 to -17 | -25.9 to -25 |
| -18.9 to -18 | -26.9 to -26 |
| -19.9 to -19 | -27.9 to -27 |
| -20.9 to -20 | -28.9 to -28 |
| -21.9 to -21 | -29.9 to -29 |
| -22.9 to -22 | -30.8 to -30 |
| -23.9 to -23 | |
- Major Contour is 5 meters
 - Minor Contour is 1 meter
- Interpreted Seafloor Disturbance Features**
- Linear Feature

- Notes:**
- Fugro marine survey data were collected on October 2 and 3, 2017 onboard the R/V Westerly using a high-resolution integrated multibeam bathymetric survey system.
 - Differential Global Positioning System (DGPS) corrections were obtained from Fugro's Omnistar GNSS in real-time via a G2 subscription.
 - Survey equipment utilized for data collection included the following systems:
 - Beacon Tracker 7120 302 Multibeam Echo-sounder (MBES)
 - Applan POS MV 320 (4-B Motion Reference Unit & Positioning System)
 - Applied MicroSystems Limited (AML) SmartPhoto for Sound Velocity Profiles
 - FPP's WinFrog (3.10.43) navigation and data acquisition software
 - NOAA (2012) Multibeam bathymetric data is from the National Oceanic and Atmospheric Administration's (NOAA) hydrographic survey of Block Island Sound, New York. This survey was conducted August 25 through August 28, 2012.
 - NOAA Completed Bathymetric data is a compilation of NOAA sounding files in the area that were collected between 1938 to 1979.

This document may only be used for the purposes for which it was commissioned and in accordance with the terms of engagement for that commission. Unauthorized use of this document in any form whatsoever is prohibited and is illegal under the law.

GEODEIC INFORMATION

SPHEROID:	GRS 1980
SEMI-MAJOR AXIS:	6,378,137.0000
SEMI-MINOR AXIS:	6,356,752.3141
MEAN FLATTENING:	298.257222101
ECCENTRICITY ² :	0.00672267
PROJECTION:	UNIVERSAL TRANSVERSE MERCATOR
ZONE:	18N
LONGITUDE OF ORIGIN:	ZONE 18 NORTH
FALSE EASTING:	500,000
FALSE NORTHING:	0

+ Coordinate GCS is UTM Zone 18N
+ NAD 1983, Meters



FUGRO FUGRO MARINE GEOSERVICES, INC.
 World Trade Center, Suite 350
 101 Water Main Street
 Norfolk, Virginia 23510
 Tel: (757) 625-3362
 Fax: (757) 625-3362
 www.fugro.com

INTERPRETED SEAFLOOR DISTURBANCE FEATURES FROM SURVEY 4 (OCT. 2017)
 Seafloor Monitoring Study
 Block Island Wind Farm and Transmission Project
 Offshore Rhode Island

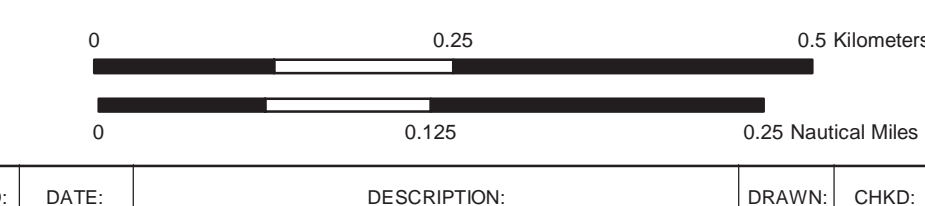

NO.	DATE	DESCRIPTION	DRAWN	CHKD	APPR.
1	Dec. 2016	Survey 5 (Dec. 2016) Report	TAW	WBC	KRS
2					
3					

JOB NUMBER: 02.81150001 CHART NO: 3

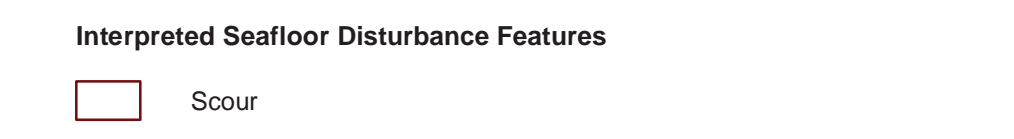
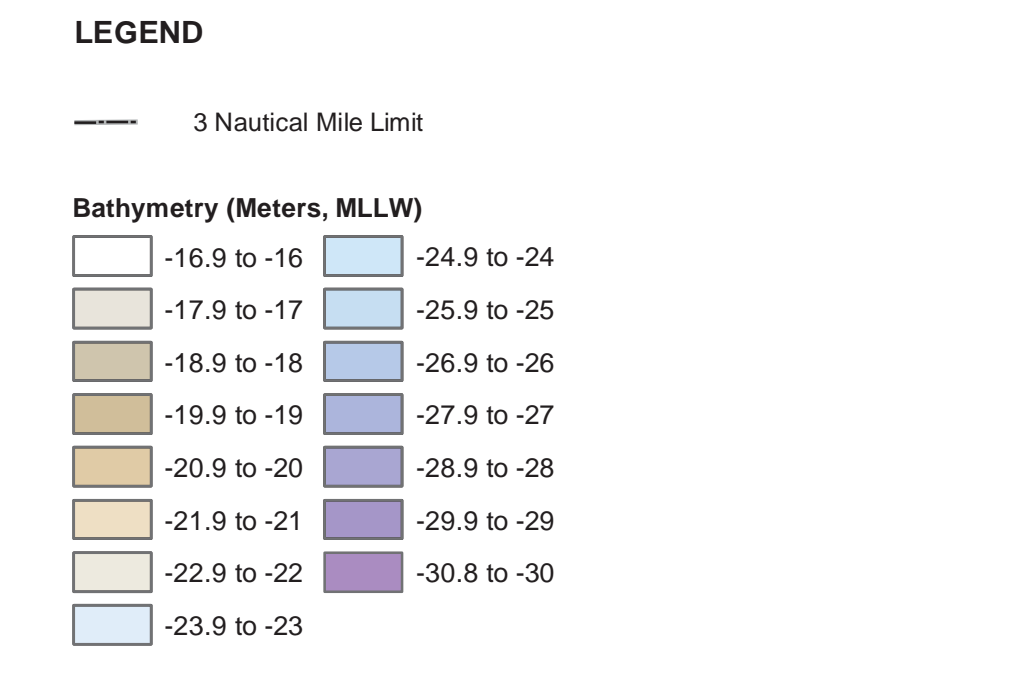
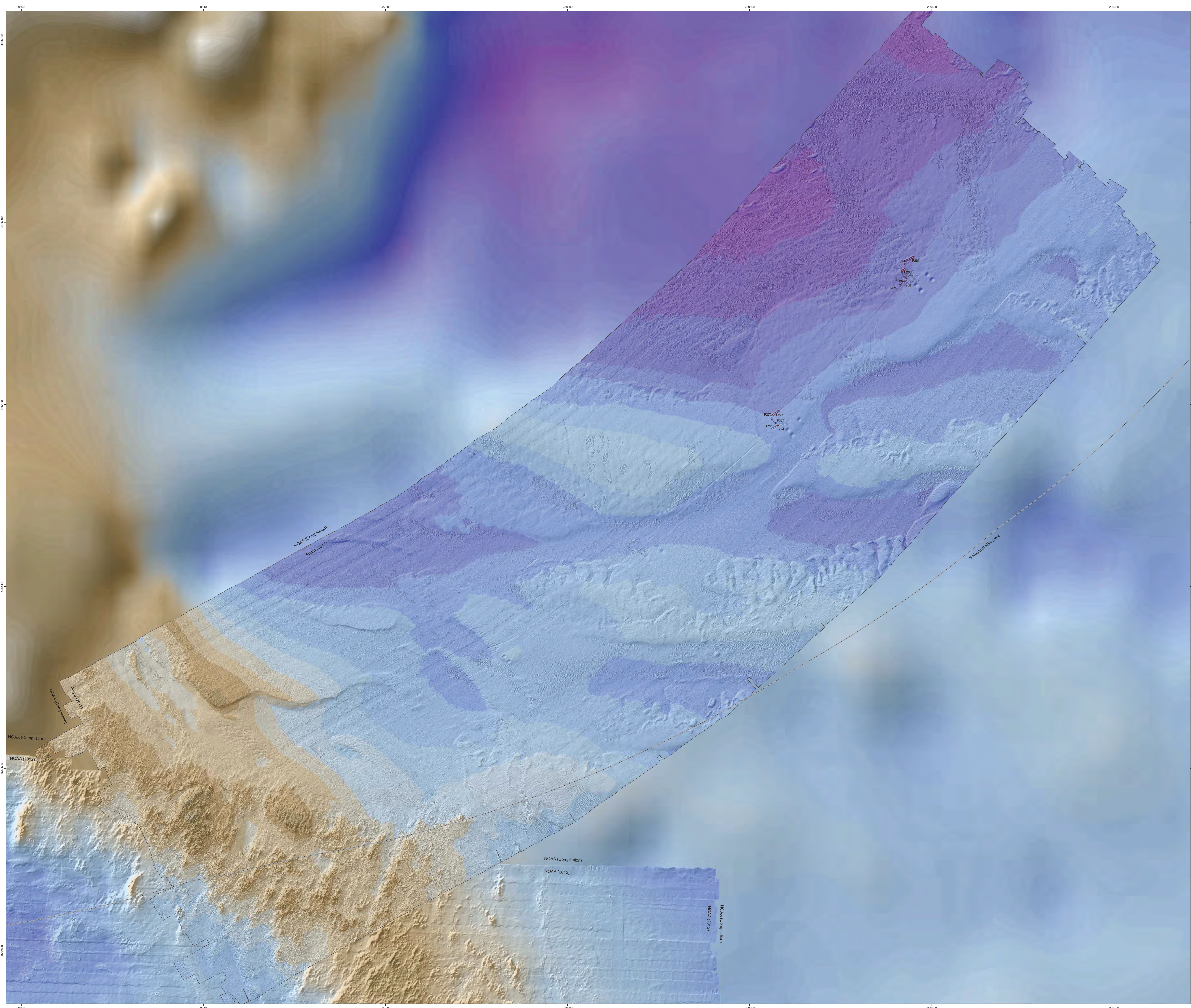

- Notes:**
- Fugro marine survey data were collected on May 18 and 19, 2017 onboard the R/V Waverly using a high-resolution integrated multibeam bathymetric survey system.
 - Differential Global Positioning System (DGPS) corrections were obtained from Fugro's Omnistar GNSS in real-time via a G2 subscription.
 - Survey equipment utilized for data collection included the following systems:
 - Hacon Seabat 7120 S12 Multibeam Echo-sounder (MBES);
 - Applan POS MV 320 (4-B Motion Reference Unit & Positioning System);
 - Applied MicroSystems Limited (AML) SonarPro for Seabed Velocity Profiles;
 - FPP's WinFrog (3.10.43) navigation and data acquisition software.
 - NOAA (2012) Multibeam bathymetric data is from the National Oceanic and Atmospheric Administration's (NOAA) hydrographic survey of Block Island Sound, New York. This survey was conducted August 25 through August 28, 2012.
 - NOAA Compiled Bathymetric data is a compilation of NOAA sounding files in the area that were collected between 1938 to 1979.

This document may only be used for the purposes for which it was commissioned and in accordance with the terms of engagement for that commission. Unauthorized use of this document in any form whatsoever is prohibited. Not for navigational use.

GEODETTIC INFORMATION

SPHEROID:	GRS 1980
SEMI-MAJOR AXIS:	6,378,137.0000
SEMI-MINOR AXIS:	6,356,752.3141
MEAN FLATTENING:	298.257222101
ECCENTRICITY ² :	0.006803411794
PROJECTION:	UNIVERSAL TRANSVERSE MERCATOR
ZONE:	18N
LONGITUDE OF ORIGIN:	70° 00' 00" WEST
FALSE EASTING:	500,000
FALSE NORTHING:	0

Coordinate Grid is UTM Zone 18N, NAD 1983, Meters

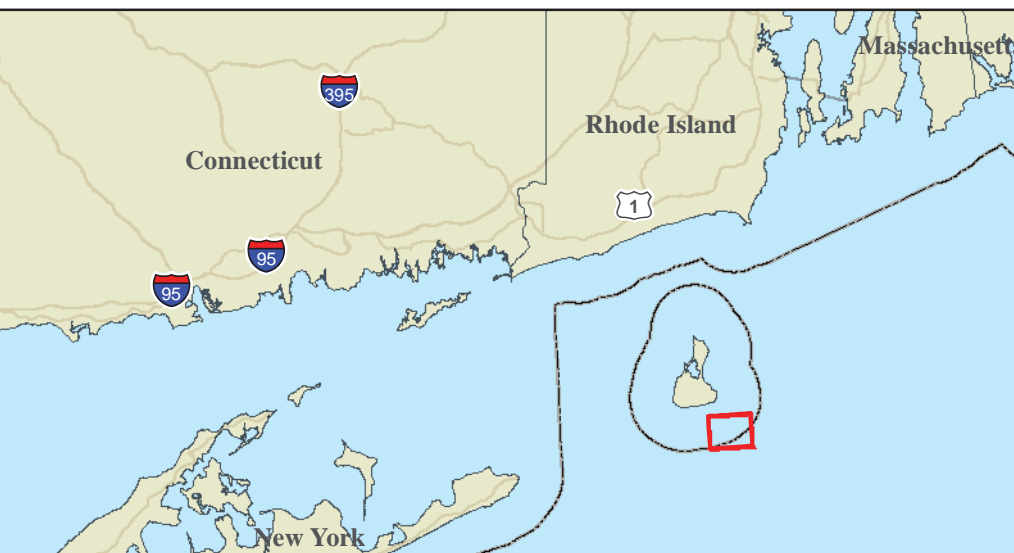

FUGRO FUGRO MARINE GEOSERVICES, INC.
 World Trade Center, Suite 350
 101 Water Main Street
 Norfolk, Virginia 23510
 Tel: (757) 625-3362
 Fax: (757) 625-3362
 www.fugro.com

SEAFLOOR DISTURBANCE FEATURE CATALOGUE FROM SURVEY 3 (MAY 2017)
 Seafloor Monitoring Study
 Block Island Wind Farm and Transmission Project
 Offshore Rhode Island

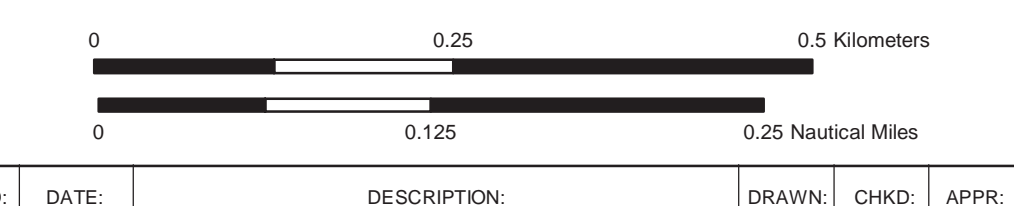

NO.	DATE	DESCRIPTION	DRAWN	CHKD	APPR
1	Dec. 2016	Survey 3 (Dec. 2016) Report	TAW	WBC	KRS
2					
3					

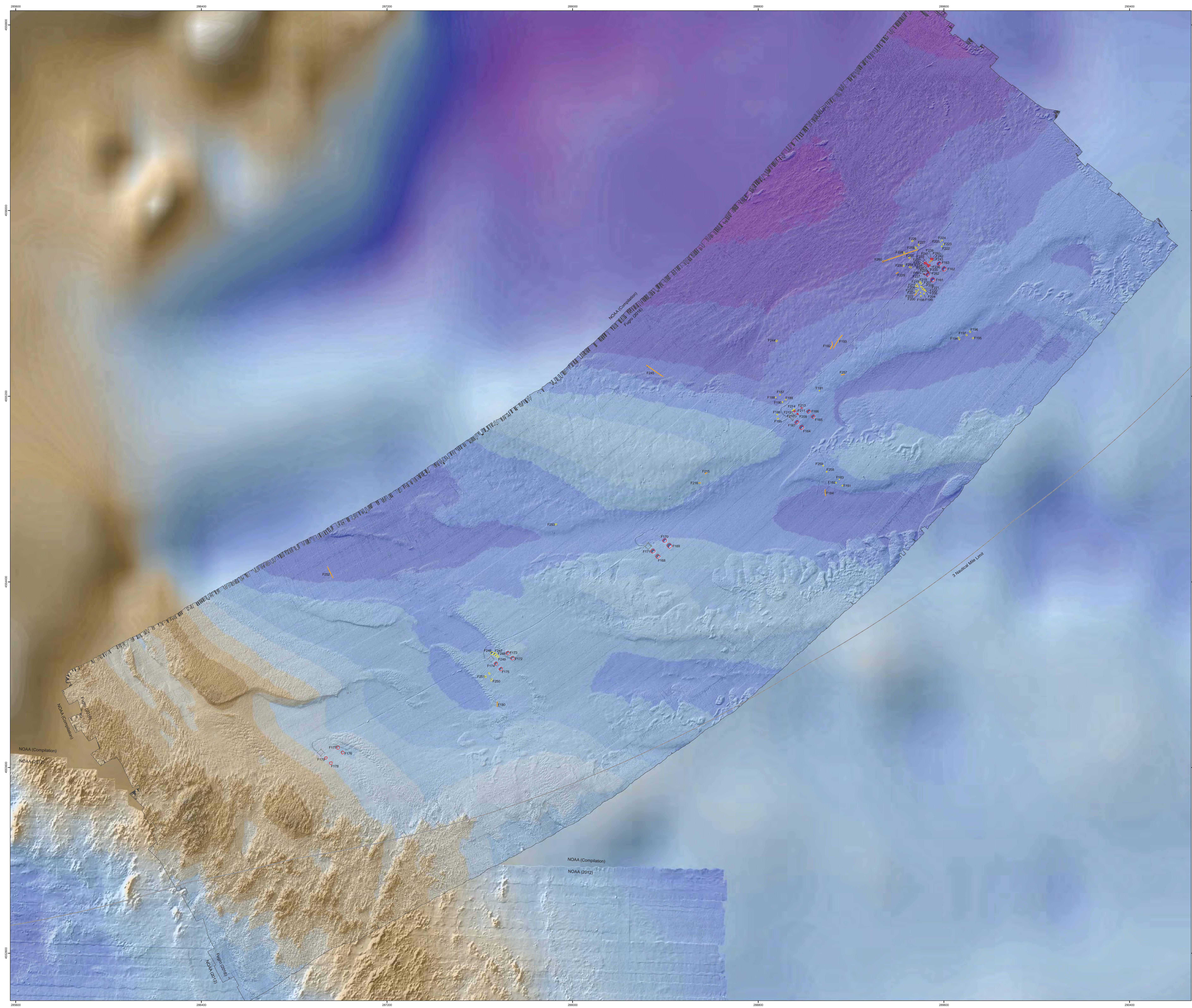

LEGEND

— 3 Nautical Mile Limit

Bathymetry (Meters, MLLW)

-16.9 to -16	-24.9 to -24
-17.9 to -17	-25.9 to -25
-18.9 to -18	-26.9 to -26
-19.9 to -19	-27.9 to -27
-20.9 to -20	-28.9 to -28
-21.9 to -21	-29.9 to -29
-22.9 to -22	-30.8 to -30
-23.9 to -23	

Interpreted Seafloor Disturbance Features

- Spud Location
- Scour
- Linear Feature
- Other Seafloor Disturbance

- Notes:**
- Fugro marine survey data were collected from October 02 through October 05, 2016 onboard the R/V Westerner using a high-resolution integrated multibeam bathymetric survey system.
 - Differential Global Positioning System (DGPS) corrections were obtained from Fugro's OnStar GNSS in real-time via a G2 subscription.
 - Survey equipment utilized for data collection included the following systems:
 - Shimadzu F125 S12 Multibeam Echo-sounder (MBE)
 - Applan POS MV 320 (4) Motion Reference Unit & Positioning System
 - Applied Microplane Limited (AML) SmartPhoto for Sound Velocity Profiles
 - IPP's WinFrog (v3.10.43) navigation and data acquisition software
 - NOAA (2012) Multibeam bathymetric data is from the National Oceanic and Atmospheric Administration's (NOAA) hydrographic survey of Block Island Sound, New York. This survey was conducted August 25 through August 28, 2012.
 - NOAA Compiled Bathymetric data is a compilation of NOAA sounding files in the area that were collected between 1938 to 1979.

This document may only be used for the purpose for which it was commissioned and in accordance with the terms of agreement for the commission. Unauthorized use of this document in any form whatsoever is prohibited. Not for navigational use.

GEODETTIC INFORMATION

SPHEROID:	GRS 1987
SEMI-MAJOR AXIS:	6 378 137.000
SEMI-MINOR AXIS:	6 356 752.314
INVERSE FLATTENING:	298.257222101
ECCENTRICITY:	0.00676281347
PROJECTION:	UNIVERSAL TRANSVERSE MERCATOR
ZONE:	18N
COORDINATE OF ORIGIN:	0
FALSE EASTING:	500 000
FALSE NORTHING:	0

↑ Coordinate Grid is UTM Zone 18N
↑ 1:63,000



FUGRO FUGRO MARINE GEOSERVICES, INC.
 World Trade Center, Suite 350
 100 West Main Street
 North Kingfield, VT 05209
 Tel: (771) 425-3300
 Fax: (771) 425-3302
 www.fugro.com

SEAFLOOR DISTURBANCE FEATURE CATALOGUE FROM SURVEY 2 (OCT. 2016)
 Seafloor Monitoring Study
 Block Island Wind Farm and Transmission Project
 Offshore Rhode Island

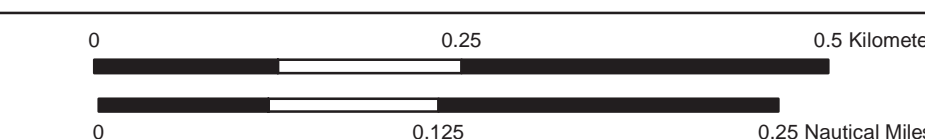

NO.	DATE	DESCRIPTION	DRAWN	CHKD	APPR
1	Dec. 2016	Survey 2 (Dec. 2016) Report	TAW	WBC	KRS
2					
3					

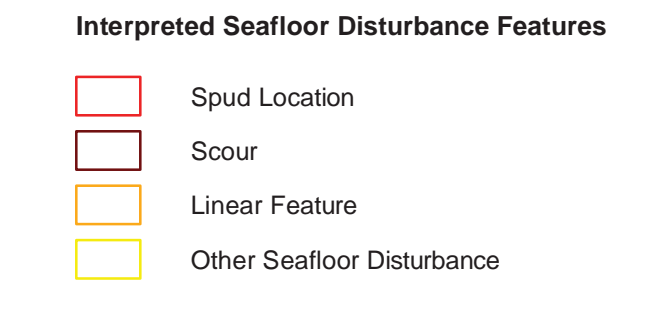
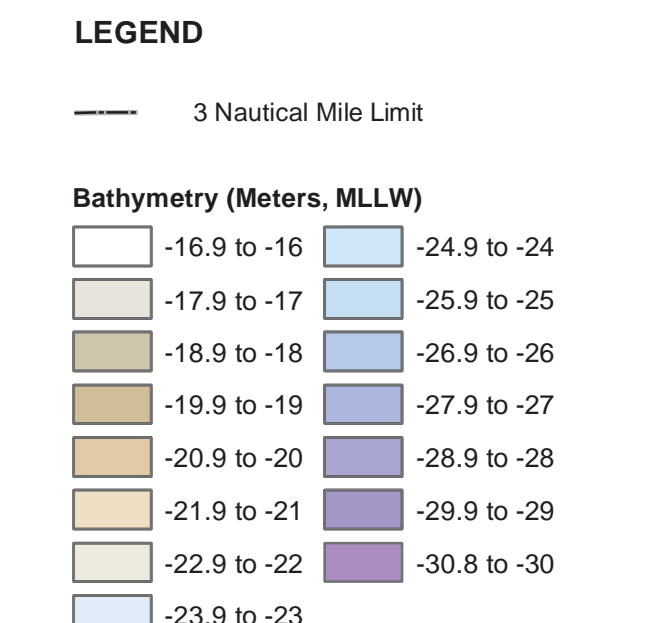
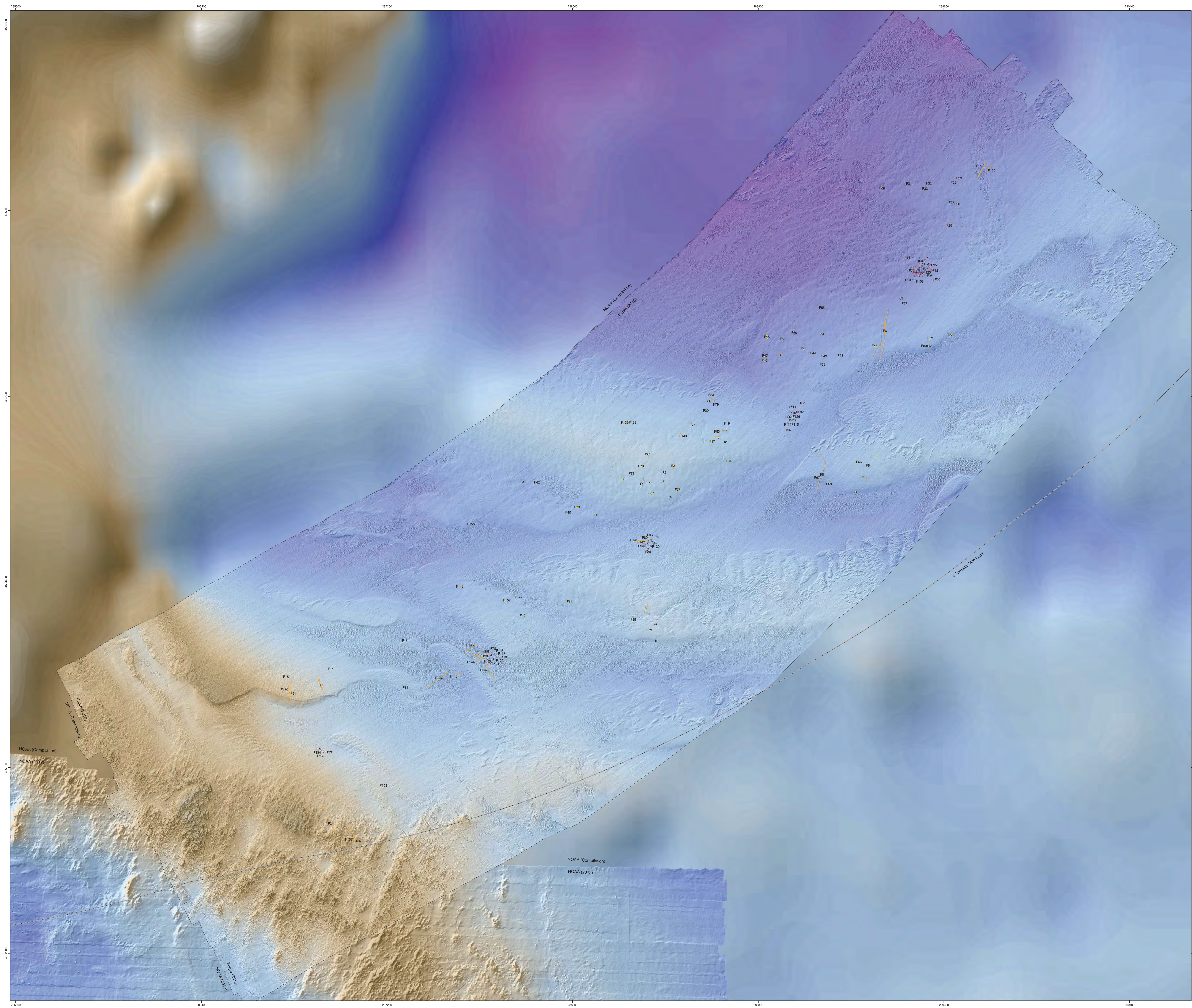

- Notes:**
- Fugro marine survey data were collected from May 11 through May 13, 2016 onboard the R/V James Herra using a high-resolution integrated multibeam bathymetric survey system.
 - Differential Global Positioning System (DGPS) corrections were obtained from Fugro's OnStar GNSS in real-time via a G2 subscription.
 - Survey equipment utilized for data collection included the following systems:
 - Shimadzu 7125 S12 Multibeam Echo-sounder (MBE);
 - Applan POS MV 320 (4-in Motion Reference Unit & Positioning System);
 - Applied MicroSystems Limited (AML) SmartPhoto for Sound Velocity Profiles;
 - FPP's WinFrog (3.10.43) navigation and data acquisition software.
 - NOAA (2012) Multibeam bathymetric data is from the National Oceanic and Atmospheric Administration's (NOAA) hydrographic survey of Block Island Sound, New York. This survey was conducted August 25 through August 28, 2012.
 - NOAA Complete Bathymetric data is a compilation of NOAA sounding files in the area that were collected between 1938 to 1979.

This document may only be used for the purposes for which it was commissioned and in accordance with the terms of engagement for that commission. Unauthorized use of this document in any form whatsoever is prohibited and is illegal under applicable law.

GEODETTIC INFORMATION

SPHEROID:	GRS 1980
SEMI-MAJOR AXIS:	6,378,137.000000
SEMI-MINOR AXIS:	6,356,752.314141
FLATTENING:	298.257222101
ECCENTRICITY ² :	0.00680348
PROJECTION:	UNIVERSAL TRANSVERSE MERCATOR
ZONE:	18N
FALSE EASTING:	500,000
FALSE NORTHING:	0

Coordinate Grid is UTM Zone 18N
NAD 1983, Meters

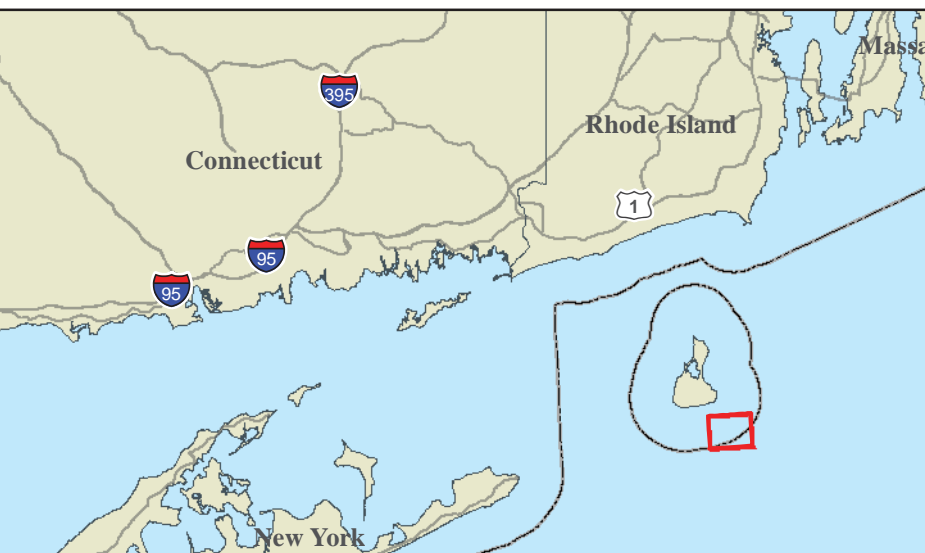

FUGRO FUGRO MARINE GEOSERVICES, INC.
 World Trade Center, Suite 350
 101 Water Main Street
 Norfolk, Virginia 23510
 Tel: (757) 625-3362
 Fax: (757) 625-3362
 www.fugro.com

SEAFLOOR DISTURBANCE FEATURE CATALOGUE FROM SURVEY 1 (MAY 2016)
 Seafloor Monitoring Study
 Block Island Wind Farm and Transmission Project
 Offshore Rhode Island

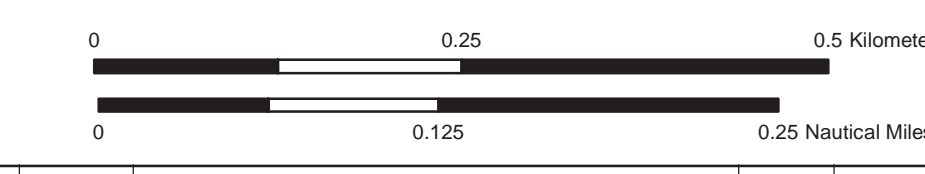

NO.	DATE	DESCRIPTION	DRAWN	CHKD	APPR
1	Dec. 2016	Survey 1 (Dec. 2016) Report	MKG	WBC	KRS
2					
3					

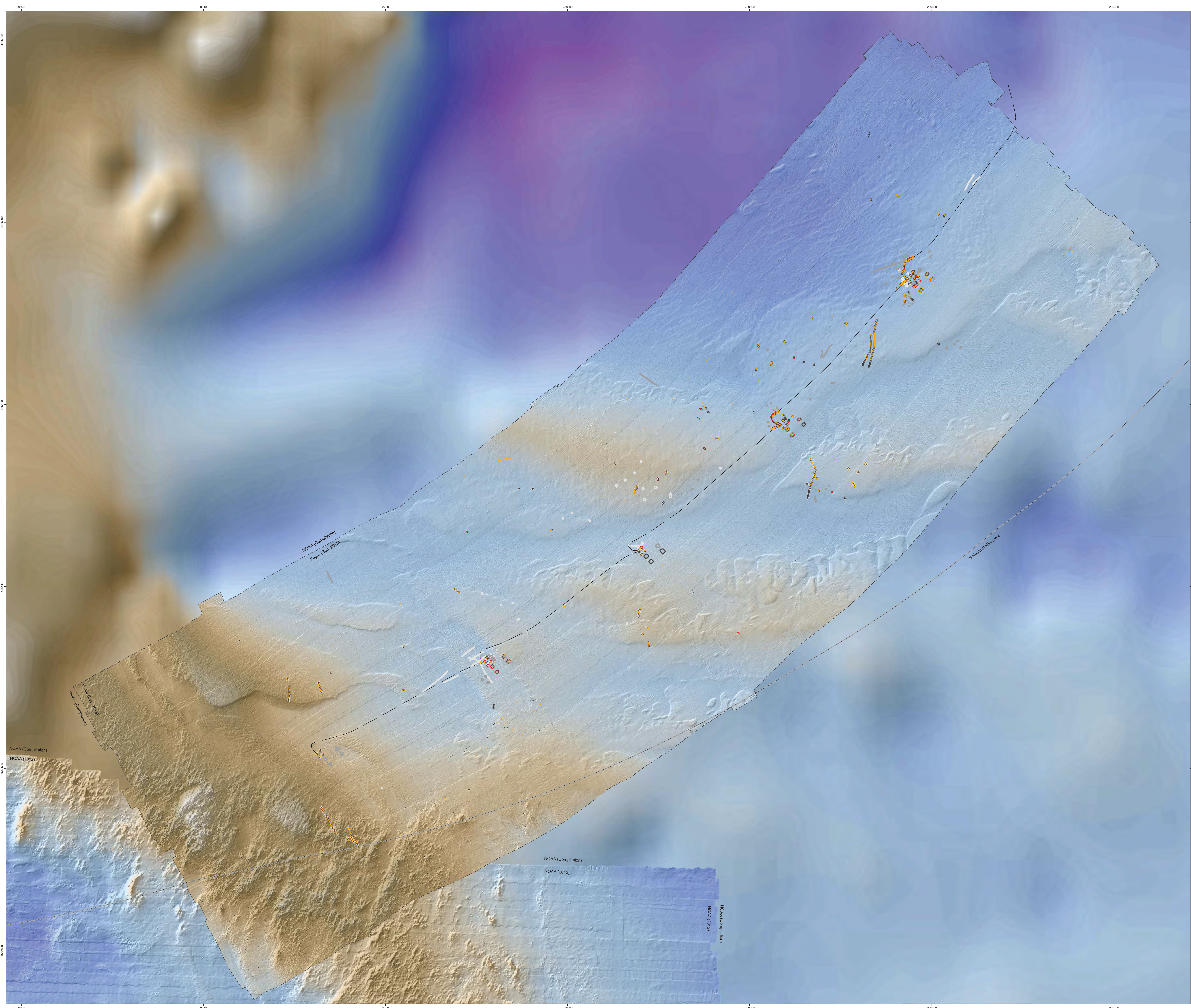

LEGEND

- Export Cable/Inter Array Cable
 - 3 Nautical Mile Limit
- Bathymetry (Meters, MLLW)**
- | | |
|-------------|-------------|
| -18.0 - -18 | -26.0 - -26 |
| -19.0 - -19 | -27.0 - -27 |
| -20.0 - -20 | -28.0 - -28 |
| -21.0 - -21 | -29.0 - -29 |
| -22.0 - -22 | -30.0 - -30 |
| -23.0 - -23 | -31.0 - -31 |
| -24.0 - -24 | -32.0 - -32 |
| -25.0 - -25 | -33.2 - -33 |
- Interpreted Seafloor Disturbance Features**
- Construction Season 1 (Survey 1-May 2016)
 - Construction Season 2 (Survey 2-Oct. 2016)
 - Survey 3 (May 2017)
 - Survey 4 (Oct. 2017)
 - Survey 5 (Sep. 2018)

Notes:

- Fugro marine survey data were collected on September 29 and 30, 2018 onboard the R/V Westley using a high-resolution integrated multibeam bathymetric survey system.
- Differential Global Positioning System (DGPS) corrections were obtained from Fugro's Omnistar (GNSS) in real-time via a G2 subscription.
- Survey equipment utilized for data collection included the following systems:
 - Shoos Seafloor 7120 302 Multibeam Echo-sounder (MBES)
 - Ashtech POS MV 320 (4th Mission Reference Unit & Positioning System)
 - Applied Microplans Limited (AML) SmartPhoto for Sound Velocity Profiles
 - FPP's WinFog (3.10.48) navigation and data acquisition software
- NOAA (2012) Multibeam bathymetric data is from the National Oceanic and Atmospheric Administration's (NOAA) hydrographic survey of Block Island Sound, New York. This survey was conducted August 25 through August 28, 2012.
- NOAA Compiled Bathymetric data is a compilation of NOAA sounding files in the area that were collected between 1938 to 1979.

This document may only be used for the purposes for which it was commissioned and in accordance with the terms of engagement for that commission. Unauthorized use of this document in any form whatsoever is prohibited and is illegal under applicable law.

GEODEIC INFORMATION

SPHEROID: GRS 1980
 SEMI-MAJOR AXIS: 6,378,137.000000
 SEMI-MINOR AXIS: 6,356,752.314141
 EPOCH: 1982.0
 ELLIPSOIDAL FLATTENING: 298.257222101
 ECCENTRICITY^2: 0.00672267767
 PROJECTION: UNIVERSAL TRANSVERSE MERCATOR
 ZONE: 18N
 FALSE EASTING: 500,000
 FALSE NORTHING: 0
 FALSE SCALE: 1.000000

Coordinate Grid is UTM Zone 18N
 NAD 1983, Meters

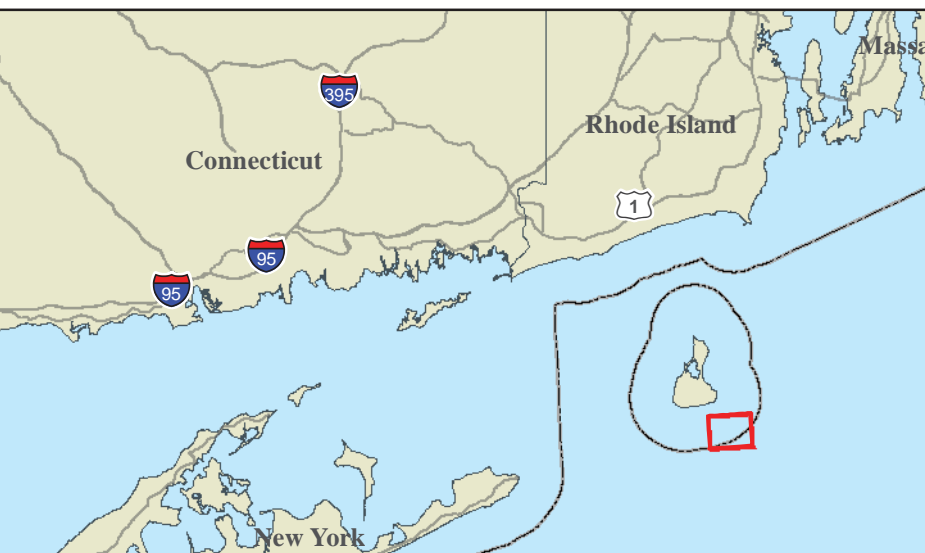

FUGRO FUGRO MARINE GEOSERVICES, INC.
 World Trade Center, Suite 350
 101 Water Main Street
 Norfolk, Virginia 23510
 Tel: (757) 625-3362
 Fax: (757) 625-3362
 www.fugro.com

INTERPRETED SEAFLOOR DISTURBANCE FEATURES PER SURVEY
 Seafloor Monitoring Study
 Block Island Wind Farm and Transmission Project
 Offshore Rhode Island

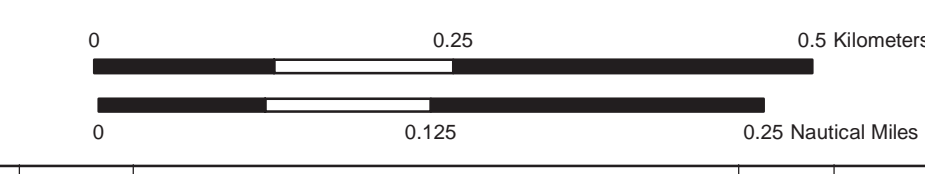

NO.	DATE	DESCRIPTION	DRAWN	CHKD	APPR
1	Dec. 2018	Survey 5 (Dec. 2018) Report	TAW	WBC	KRS
2					
3					

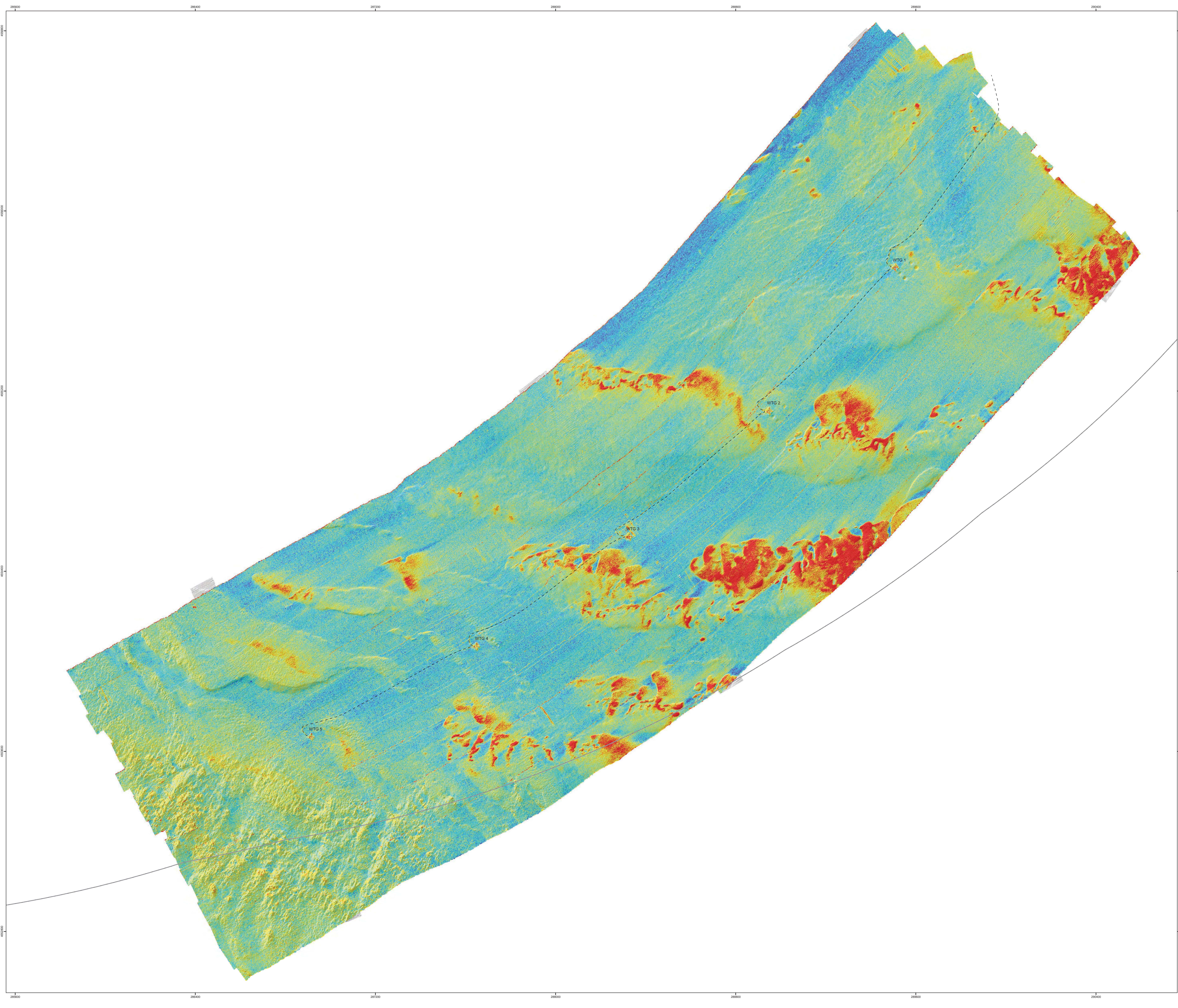

LEGEND

- - - Export Cable/Iner Array Cable
- 3 Nautical Mile Limit

Backscatter Intensity (dB)

- Less than -35
- 35.8 - -35
- 34.9 - -34.2
- 34.1 - -33.3
- 33.2 - -32.5
- 32.4 - -31.6
- 31.5 - -30.8
- 30.7 - -29.9
- 29.8 - -29.1
- 29 - -28.2
- 28.1 - -27.4
- 27.3 - -26.6
- 26.5 - -25.7
- 25.6 - -24.9
- 24.8 - -24
- 23.9 - -7.48

Notes:

- Fugro marine survey data were collected on September 28 and 30, 2018 onboard the R/V Waverly using a high-resolution integrated multibeam bathymetric survey system.
- Differential Global Positioning System (DGPS) corrections were obtained from Fugro's ChirixStar GNSS in real-time via a G2 subscription.
- Survey equipment utilized for data collection included the following systems:
 - Shoan Seabed 7120 302 Multibeam Echo-sounder (MBES);
 - Applan POS MV 320 (4-B Motion Reference Unit & Positioning System)
 - Applied MicroSystems Limited (AML) SonarPro for Seabed Velocity Profiles
 - FPP's WinFrog (3.10.48) navigation and data acquisition software

This document may only be used for the purposes for which it was commissioned and in accordance with the terms of engagement for that commission. Unauthorized use of this document in any form whatsoever is prohibited and is illegal.

GEODEIC INFORMATION

SPHEROID: GRS 1980
 SEMI-MJOR AXIS: 6,378,137.0000
 SEMI-MINOR AXIS: 6,356,752.3141
 ELLIPSOID FLATTENING: 298.257222101
 ECCENTRICITY²: 0.00669437999
 PROJECTION: UNIVERSAL TRANSVERSE MERCATOR
 ZONE: ZONE 18 NORTH
 FALSE EASTING: 500,000
 FALSE NORTHING: 0
 Coordinate Grid is UTM Zone 18N, NAD 1983, Meters

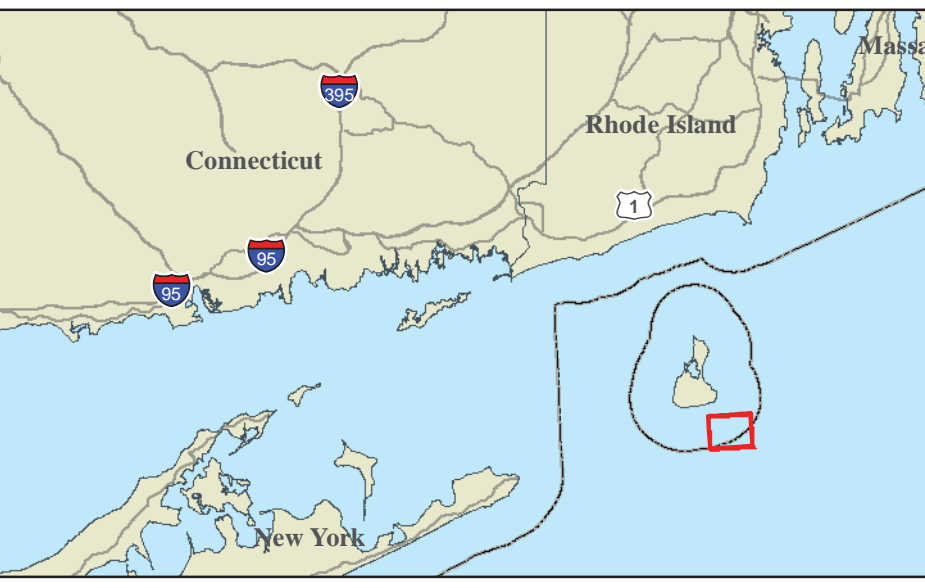

FUGRO FUGRO MARINE GEOSERVICES, INC.
 World Trade Center, Suite 350
 107 Water Main Street
 Norfolk, Virginia 23510
 Tel: (757) 625-3362
 Fax: (757) 625-3362
 www.fugro.com

SURVEY 5 (SEPTEMBER 2018)
MBES BACKSCATTER
 Seafloor Monitoring Study
 Block Island Wind Farm and Transmission Project
 Offshore Rhode Island

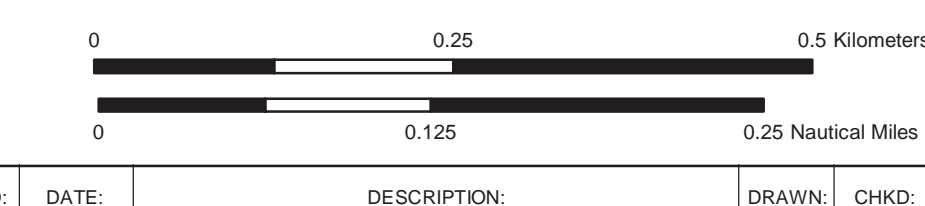

NO.	DATE	DESCRIPTION	DRAWN	CHKD	APPR.
1	Dec. 2017	Survey 5 (Dec. 2018) Report	TAW	WBC	KRS
2					
3					

A. BATHYMETRIC SURVEY VESSEL SPECIFICATIONS



A. SURVEY ACQUISITION AND PROCESSING

Fugro Marine GeoServices, Inc., Fugro, was contracted by HDR to perform a bathymetric survey of the Block Island Wind Farm. Survey operations were carried out on October 2 and 3, 2017. Multibeam bathymetry was acquired to provide current sounding data for the area in the vicinity of the wind turbines.

Data were acquired using a high-resolution integrated multibeam bathymetric survey system. The water depths surveyed ranged from approximately 20 to 32 meters in the wind farm area, based on the charted datum of Mean Lower Low Water (MLLW).

A.1 DATA ACQUISITION

A.1.1 Vessel

The *R/V Westerly*, a 50-foot survey vessel, was used for the project. The vessel was equipped with the following primary equipment for execution of the survey:

- Two R2Sonic Sonic 2024 Multibeam Echosounders (MBES)
- Applanix POS MV 320 (v4) Motion Reference Unit & Positioning System
- Applied Microsystems Limited (AML) SmartProbe, for Sound Velocity Profiles
- FPI's WinFrog (v3.10.49) navigation and data acquisition software.

A.1.2 GPS Vessel Positioning

Primary positioning data was provided by the POS MV 320 system. Position was determined in real time using a Trimble Zephyr L1/L2 GPS antenna, which was connected to a Trimble BD960 L1/L2 GPS card residing in the POS MV. An Inertial Measurement Unit (IMU) provided velocity values to the POS MV allowing it to compute an inertial position based on Differential GPS (DGPS), heading, and motion.

The POS MV was configured to accept differential corrections in the WGS84 (g1150) reference frame, received from Fugro's OmniStar GNSS subscription.

The POS MV controller software's real-time QC displays were monitored throughout the survey to ensure positional accuracies stayed within industry standards. These displays include, but are not limited to GPS Status, Position Accuracy, Receiver Status (which included HDOP), and Satellite Status.

WinFrog (v. 3.10.49) navigation software, running on a Windows 7-based PC, was used for vessel navigation. WinFrog presented vessel position data in graphical and tabular format for QC purposes. The following display windows were used:

- Graphics – the Graphics window showed an overview of navigation, including vessel position and orientation, survey lines, background plots, charts, and waypoints.
- Vehicle – the Vehicle window was configured to show tabular navigation information. This window displayed position, time, line name, heading, course over ground, speed, and data/event status.



A.1.3 Project Datum

All bathymetry was processed in WGS84 (g1150). The data were projected in Universal Transverse Mercator (UTM), zone 19 North.

TABLE 1 – PROJECT DATUM

Datum	WGS 1984 (g1150)
Ellipsoid/ Spheroid	WGS 1984
Semi-Major Axis	6378137.00 m
Semi-Minor Axis	6356752.314245179 m
Inverse Flattening (1/f)	298.257223563
Projection	UTM
Zone	19 North
Unit	Meters
Latitude of Origin	0.0°
Central Meridian (CM)	-69.0°
False Easting	500,000 m
False Northing	0 m
Scale Factor	0.9996

A.1.4 Vertical Datum

Bathymetric data were reduced to MLLW based on tidal data from NOAA’s predicted tide data for Block Island (predicted tide gauge #8459338). Predicted tides do not account for local effects, such as weather. Thus, predicted tides are rarely accurate enough for IHO Order 1a survey. To correct the tide model inaccuracies, the variance between the predicted tide data and the observed tide data from tide gauges in the region was used to adjust the predicted tide data from gauge 8459338. In this way, the predicted tide model was shifted to a pseudo-observed tide model that better accounted for local effects, such as weather.

A.1.5 Motion Sensor and Vessel Heading

A POS MV 320 motion sensor system measured the vessel’s dynamic motion and orientation (heave, pitch, roll and heading). The system consists of an inertial motion unit (IMU), two GPS receivers, and a processing unit.

The IMU uses a series of linear accelerometers and angular rate sensors that work in tandem to determine vessel attitude solutions. The combined GPS solution of each antenna is used to calculate the orientation and heading of the vessel. Offsets for the IMU and GPS antenna are presented in the vessel offset diagram in Figure A-1.

Motion, heading, and position data were sent to WinFrog for navigation and data logging purposes during MBES acquisition.

A.1.6 Sound-Velocity Profiles

Sound-velocity profile (SVP) data were acquired using an Applied Microsystems Ltd. (AML) Smart Probe. The AML Smart probe measures at a maximum rate of 10 velocity and pressure observations per second. For each cast, the probe was held at the surface for approximately two minutes to reach temperature equilibrium. The probes were then manually lowered at the rate of about 1 m/s to the seafloor and raised to the surface at the same rate.

Sound-velocity casts were conducted regularly to ensure MBES data could be corrected for refraction. Casts were spaced geographically and temporally to create an accurate model of the sound velocity profile for the water column across the survey area.

A.1.7 Multibeam Echosounder

The *R/V Westerly* was equipped with an over-the-stern, pole-mounted dual-head R2Sonic Sonic 2024 MBES system, designed to operate between water depths of 0.5 m to 500 m. The two multibeam sonars were mounted with a 30-degree vertical offset between the port and starboard transducers. The MBES was used to collect bathymetry data over the entire area. Survey speed was kept between 4 to 7 knots to ensure low turbulence around the multibeam transducer pole.

Data received by the Sonic sonar-processing unit was sent to WinFrog, where bathymetry quality was continually monitored during acquisition. Various windows displayed a 3D bathymetry profile, sonar beam amplitude measurements, and swath coverage to allow adjustments to sonar settings or vessel speed, when appropriate. A parameter window also displayed position, speed, heading, and attitude data that was received from the POS MV 320.

WinFrog was used to start and stop data logging in .S7K file format and to name lines. Power, gain, and range settings were controlled directly through the Sonic user interface monitor and varied according to water depth and data quality. Settings were noted on the multibeam line logs, using FPI's MB Survey Tools software.

A.2 DATA PROCESSING

A.2.1 HORIZONTAL AND VERTICAL CONTROL

The real-time navigation and position data were used as the geodetic control, receiving Differential GNSS corrections in real-time via a G2 subscription to Fugro's OmniStar service.

All real-time positioning data were converted to WGS84 (g1150) in the Applanix POS MV. This real-time positioning was used to process the multibeam survey lines.

A.2.2 Vertical Control

The vertical datum for this project was from NOAA tide stations in the region, specifically adjusted tide data from NOAA's predicted tide gauge at Block Island (NOAA gauge #8459338).

A.2.3 Bathymetry

All soundings were processed using CARIS HIPS software on Windows 7 workstations. CARIS was used to process, clean, and produce Digital Terrain Models (DTM) and finalized XYZ ASCII files.

A.2.4 Corrections to Bathymetry Data

Within CARIS HIPS, Sonic 2024 SV2 soundings were corrected for calibrated patch test results, vessel offsets, vessel motion, draft, sound velocity, and tide.

A.2.5 Vessel Offsets

Offsets established during the mobilization were used to correct bathymetry for differences between the transducer head and GPS antenna position. Offsets are detailed in Figure A-1. Offsets were entered in the Vessel Configuration File in CARIS HIPS to correct the bathymetry during processing.

A.2.6 Sound Velocity Profiles

Processed sound velocity profiles were used to correct bathymetry data for sound refraction, or ray bending.

SVP's were applied within CARIS. FPI's Multibeam Survey Tools v 3.1.30 software was used to process the SVP data set, generating a smooth interpolation curve that depicted the original profile at the finest resolution available in CARIS.

A.2.7 Static Draft

Static draft observations were measured at the over-the-stern mount of the *R/V Westerly*. The correction was then applied to bring soundings from the transducer level to the water level. The static draft value was entered into the HIPS Vessel File (HVF) within CARIS HIPS. It should be noted that draft is actually distance from the common reference point (CRP) to the water level; CARIS takes into account the distance from the CRP to the transducer head in its calculations.

A.2.8 Data Cleaning

The .S7K files were converted to CARIS HIPS format for bathymetry processing. Prior to each survey line being converted from .S7K to CARIS' HIPS format, the vessel offsets, patch test calibration values and static draft measurements were entered into the HVF. The SVP file was then loaded into each line, and the line was corrected for sound refraction. During SVP correction the bathymetry was also corrected for dynamic vessel heave, pitch and roll. The attitude, heading, navigation, and bathymetry data were examined for noise and gaps. Beam filters were used to reject data from the outer beams of the swaths. It should be noted that rejection does not mean deletion from the data set; soundings were simply flagged as 'rejected' and could be re-accepted if necessary.

After each individual line was examined and cleaned in CARIS' Swath Editor (Figure A-1), the tide file was loaded, and the lines were merged. During merging, tide and draft corrections were applied. Subsets were then created in CARIS' Subset Editor mode (Figure A-2), and adjacent overlapping lines of corrected bathymetry data were examined to identify any tidal busts, sound velocity errors, motion errors, or data gaps. Any residual noise in the data set was manually rejected at this time.

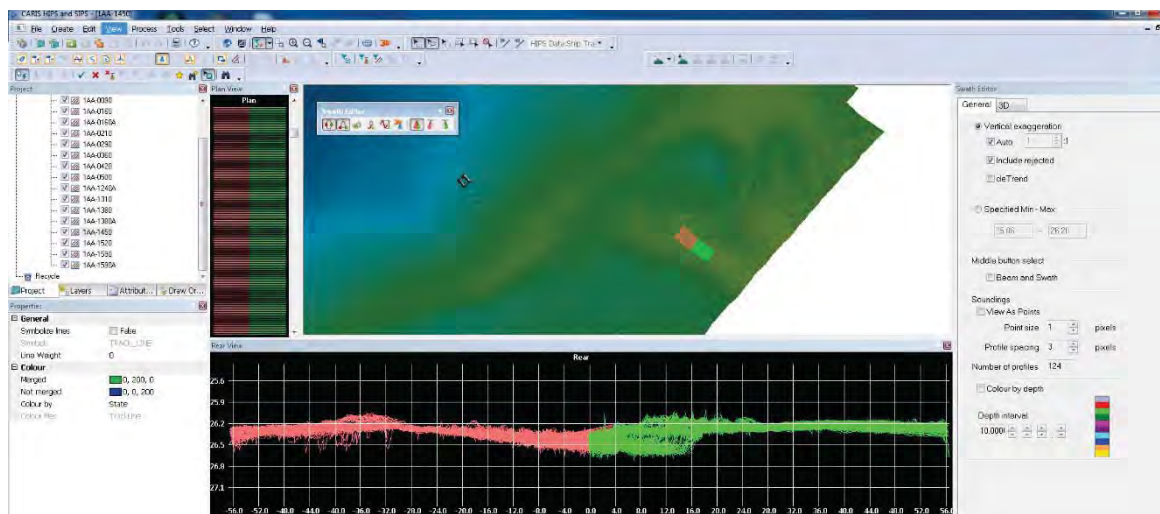

FIGURE A-1 CARIS SWATH EDITOR

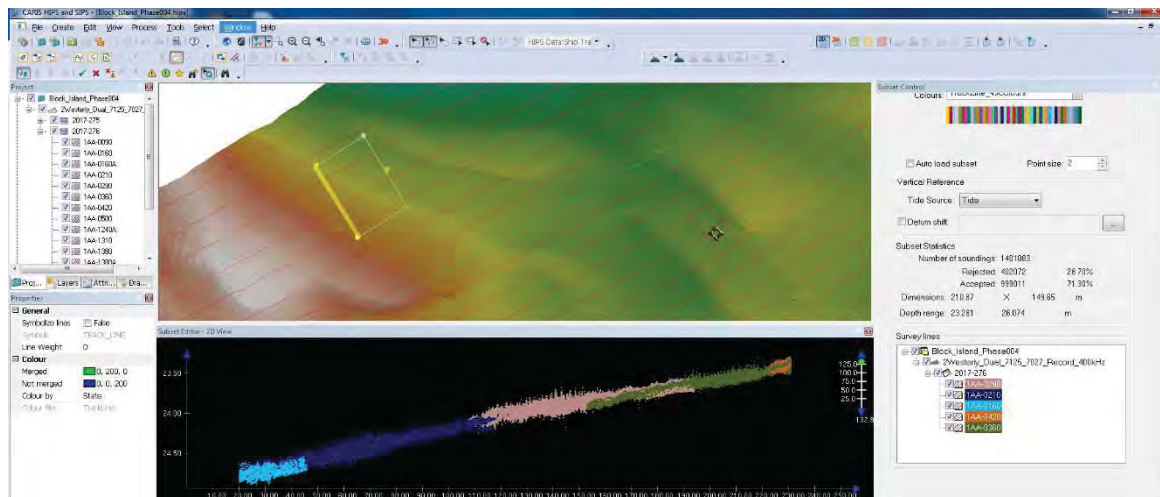

FIGURE A-2 CARIS SWATH SUBSET EDITOR

A.2.9 DTM Generation

Once all cleaning and processing was completed, a DTM was generated with CARIS' CUBE surface routine, thus depicting a mean seafloor. Final DTM grid size was 0.5 m.

Sun-illuminated images of the DTM grids were created within CARIS using the image-manager. These images were then exported as GeoTiffs.

A.2.10 XYZ Generation

CARIS HIPS was used to export the CUBE surface model to an ASCII XYZ grid of Eastings, Northings, and Depth values in meters. The XYZ file was delivered with a grid spacing of 0.5 meters by 0.5 meters.



A.3 CALIBRATIONS AND QUALITY CONTROL

During both data acquisition and processing, various calibrations and quality control (QC) measures were performed to ensure the data met the project’s accuracy specifications.

A.3.1 Vessel Offset Survey

During vessel mobilization, the offset values from the POS MV’s IMU to the sonar and GNSS antennas were obtained using total station.

A.3.2 MBES Patch Test Calibration

An MBES patch test calibration was carried out on September 29, 2018 to verify the mounting offsets between the sonar heads and motion reference unit. Each sonar head of the dual-head system was calibrated independently. A patch test uses seafloor topology to bring swaths run at varying speeds, headings, and overlaps into coincidence. Patch tests are employed to correct the data for navigation timing, pitch, roll, and azimuth offsets, which may exist between the MBES transducers and the IMU.

Patch Test values were obtained in CARIS HIPS calibration mode within the Subset Editor routine. Calculated values were then entered in the HVF to ensure all survey data would be corrected for these offsets during processing (Table 2). As the dual-head sonar system has two distinct Sonic 2024 transducers, both the port and starboard transducer required calibration during the patch test.

TABLE 2 – PATCH TEST CALIBRATION

Calibration Offset	Correction
Navigation Timing Error	0.000 s
Port Sonar Pitch Offset	-1.650°
Port Sonar Roll Offset	16.360°
Port Sonar Azimuth (Yaw) Offset	-0.650°
Starboard Sonar Pitch Offset	-1.600°
Starboard Sonar Roll Offset	-14.875°
Starboard Sonar Azimuth (Yaw) Offset	-2.050°

A.3.3 MBES Crosslines

Two crosslines were acquired during this phase of the project. Crossline quality control reports were run in CARIS HIPS software to ensure the data met IHO Order 1a specifications. This crossline analysis was used in conjunction with the total propagated uncertainty values for the data, ensuring project specifications were met. Likewise, the bathymetry from this phase of the project was compared to bathymetry from previous phases. The peaks of rocks should always align, as the rocks are not shifting on the seafloor. (Similar types of testing are less reliable over sandy seafloors due to sediment transfer causing erosion or deposition.) Thus, the combination of bathymetry comparison across different survey phases, analysis of total propagated uncertainty, and the analysis of crossline quality control reports was used to confirm that the data met IHO Order 1a specification.

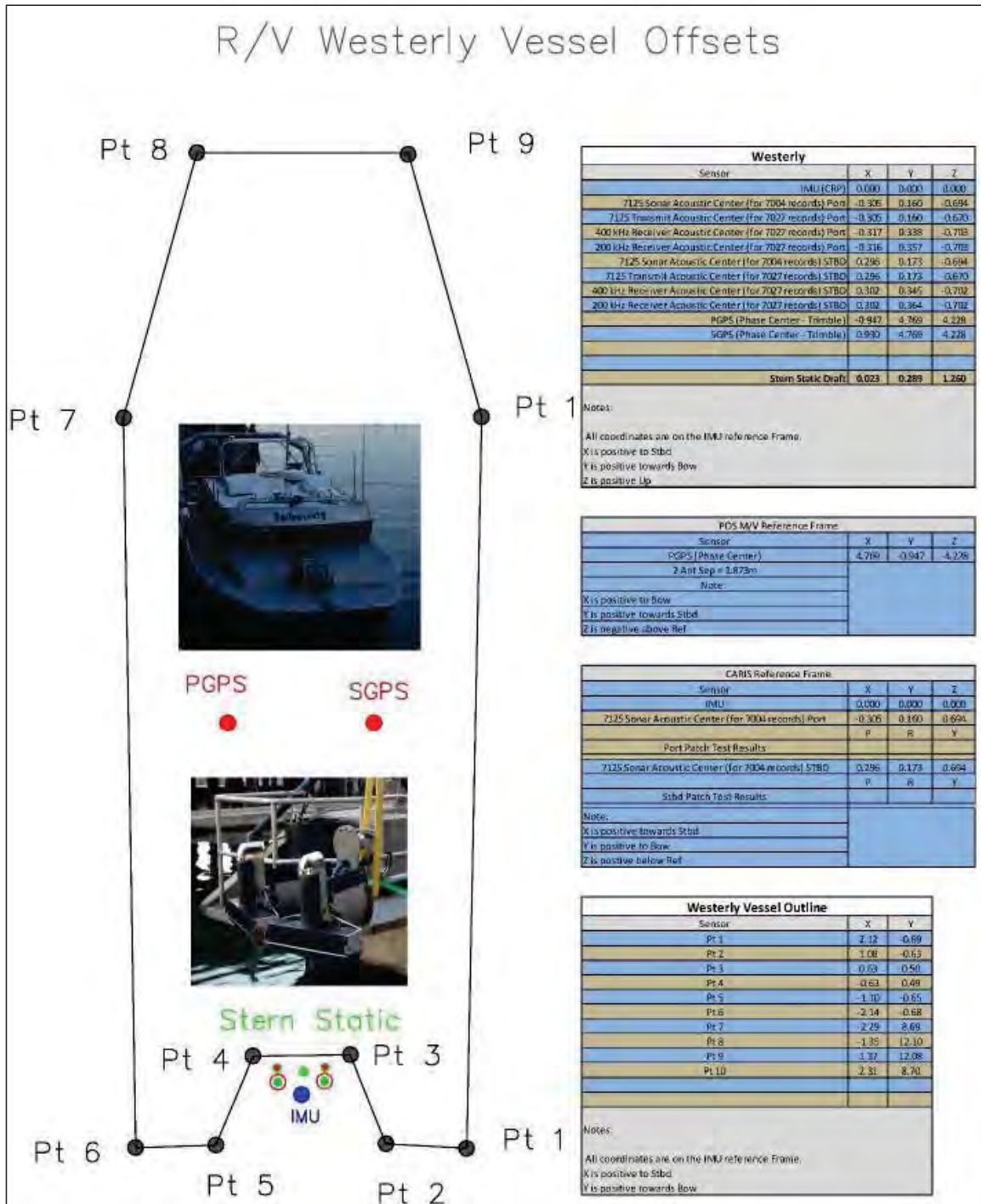

VESSEL OFFSET DIAGRAM FOR THE R/V WESTERLY
Seafloor Monitoring Study
Block Island Wind Farm and Transmission Project
Offshore Rhode Island

Figure A-3

B. INSTALLATION VESSEL SPECIFICATIONS

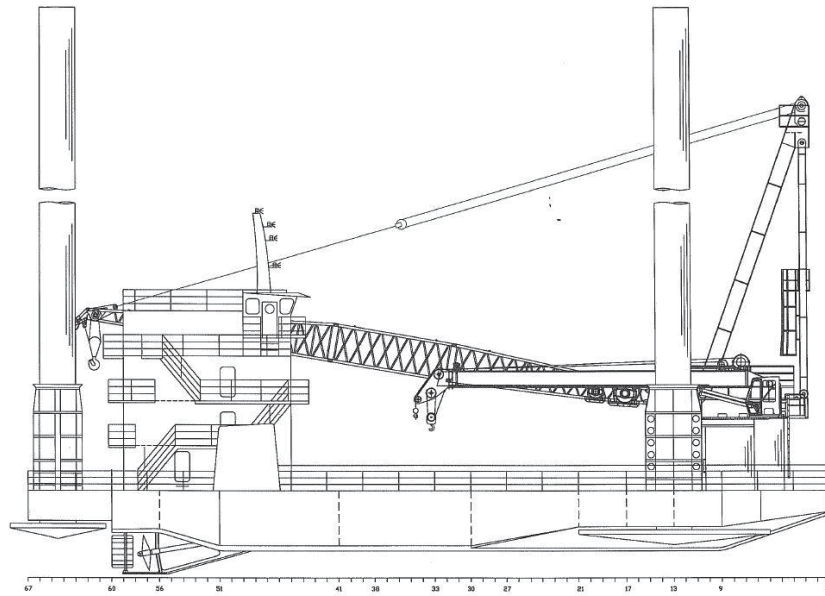

GENERAL ARRANGEMENT MAIN DECK
SCALE 3/16" = 1'-0"

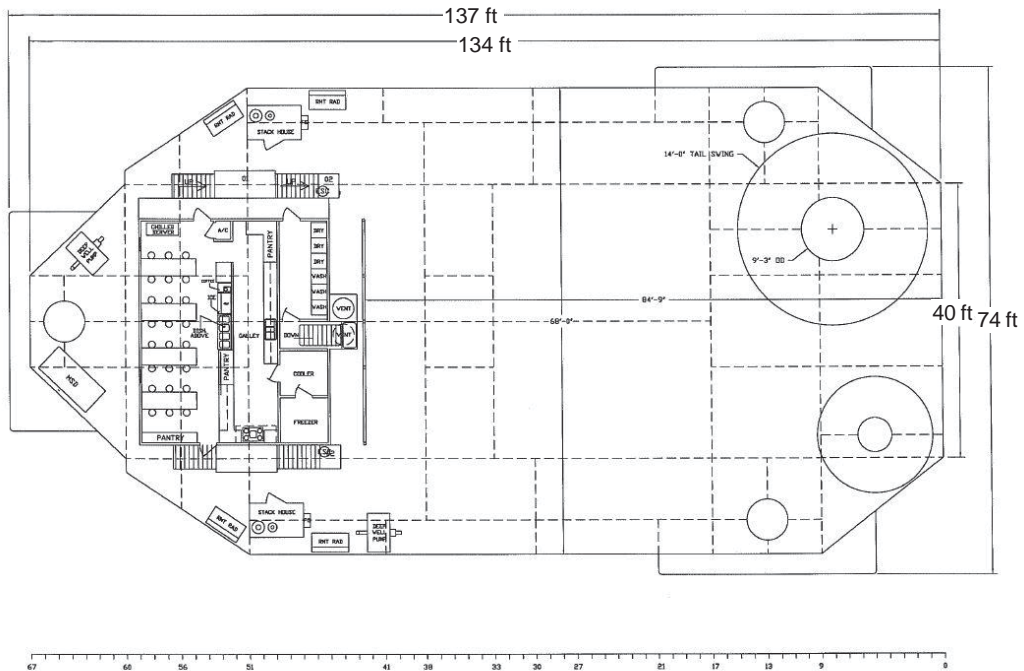

GENERAL ARRANGEMENT MAIN DECK
SCALE 3/16" = 1'-0"

VESSEL SPECIFICATIONS FOR THE *L/B MICHAEL EYMARD*
Seafloor Monitoring Study
Block Island Wind Farm and Transmission Project
Offshore Rhode Island

FIGURE B-1

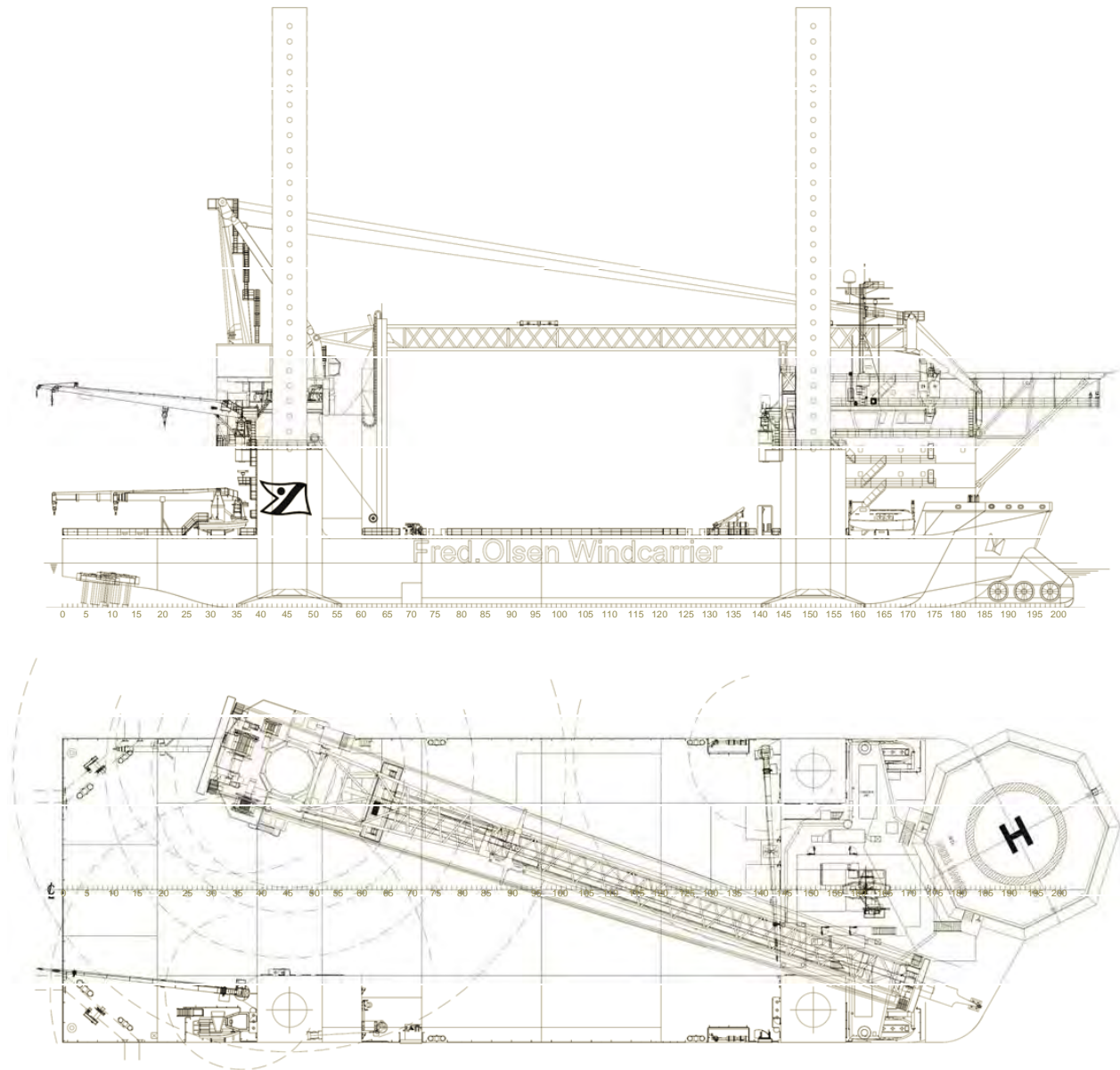

VESSEL SPECIFICATIONS FOR THE L/B *BRAVE TERN*
Seafloor Monitoring Study
Block Island Wind Farm and Transmission Project
Offshore Rhode Island

FIGURE B-2

C. CATALOG OF SEAFLOOR DISTURBANCE FEATURES

Table C-1. Seafloor Disturbance Features (Survey 5 - Sep. 2018)

Feature ID	Northing ¹ (m)	Easting ¹ (m)	Elevation ² (m)	Feature Perimeter (m)	Feature Area (m ²)	Max Depth (m)	Feature Interpretation	Attributed Vessel	Construction Season	Relative Change
F0	4554820	288297	-25.0	54	120	0.17	Drag Mark	Unknown	1	Some Change ³
F1	4554840	288306	-25.0	39	82	0.16	Drag Mark	Unknown	1	Some Change ³
F2	4554870	288395	-24.8	36	72	0.14	Drag Mark	Unknown	1	Mostly Healed
F3	4554900	288433	-24.8	37	76	0.22	Drag Mark	Unknown	1	Little Change
F4	4554770	288418	-25.4	33	59	0.17	Drag Mark	Unknown	1	Mostly Healed
F5	4555020	288625	-25.4	49	108	0.13	Drag Mark	Unknown	1	Mostly Healed
F6	4555470	289343	-27.0	441	983	0.12	Drag Mark	Unknown	1	Some Change ³
F7	4555440	289322	-26.9	310	603	0.11	Drag Mark	Unknown	1	Some Change ³
F8	4554860	289072	-26.2	380	595	0.15	Drag Mark	Unknown	1	Some Change ³
F9	4554290	288314	-24.4	86	205	0.13	Drag Mark	Unknown	1	Some Change ³
F10	4554150	288357	-25.1	54	97	0.11	Drag Mark	Unknown	1	Little Change

Notes: See Charts 3, 4, 5, and 6 for the location of each seafloor disturbance feature.

¹ UTM Zone 19, NAD83, Meter

² Elevation represents centroid location of the feature.

³ Change was infilling of feature.

⁴ Change was deepening of feature.

Feature ID	Northing ¹ (m)	Easting ¹ (m)	Elevation ² (m)	Feature Perimeter (m)	Feature Area (m ²)	Max Depth (m)	Feature Interpretation	Attributed Vessel	Construction Season	Relative Change
F11	4554320	287986	-25.6	30	59	0.25	Circular Depression	Unknown	1	Some Change ³
F12	4554260	287784	-25.7	25	38	0.13	Circular Depression	Unknown	1	Mostly Healed
F13	4554370	287624	-26.2	19	24	0.09	Circular Depression	Unknown	1	Mostly Healed
F14	4553940	287279	-25.4	23	34	0.13	Circular Depression	Unknown	1	Little Change
F15	4553960	286913	-23.5	95	155	0.12	Drag Mark	Unknown	1	Some Change ³
F16	4555050	288655	-25.7	35	74	0.2	Drag Mark	Unknown	1	Some Change ³
F17	4555010	288601	-25.3	26	42	0.15	Circular Depression	Unknown	1	Mostly Healed
F18	4555000	288653	-25.4	23	34	0.09	Circular Depression	Unknown	1	Mostly Healed
F19	4555080	288665	-25.9	22	35	0.07	Circular Depression	Unknown	1	Mostly Healed
F20	4555140	288574	-26.3	33	69	0.14	Circular Depression	Unknown	1	Little Change
F21	4555180	288585	-26.7	30	48	0.18	Drag Mark	Unknown	1	Mostly Healed
F22	4555190	288606	-26.7	37	56	0.12	Drag Mark	Unknown	1	Little Change
F23	4555210	288597	-27.0	24	31	0.13	Drag Mark	Unknown	1	Mostly Healed

Notes: See Charts 3, 4, 5, and 6 for the location of each seafloor disturbance feature.

¹ UTM Zone 19, NAD83, Meter

² Elevation represents centroid location of the feature.

³ Change was infilling of feature.

⁴ Change was deepening of feature.

Feature ID	Northing ¹ (m)	Easting ¹ (m)	Elevation ² (m)	Feature Perimeter (m)	Feature Area (m ²)	Max Depth (m)	Feature Interpretation	Attributed Vessel	Construction Season	Relative Change
F24	4554850	289258	-26.0	50	73	0.16	Drag Mark	Unknown	1	Some Change ³
F25	4555940	289623	-28.0	60	151	0.09	Drag Mark	Unknown	1	Mostly Healed
F26	4556030	289655	-28.1	29	51	0.08	Circular Depression	Unknown	1	Little Change
F27	4556030	289632	-28.1	30	53	0.08	Circular Depression	Unknown	1	Little Change
F28	4556120	289641	-28.2	26	41	0.1	Circular Depression	Unknown	1	Mostly Healed
F29	4556140	289665	-28.3	28	54	0.19	Circular Depression	Unknown	1	Mostly Healed
F30	4556100	289334	-29.6	27	51	0.07	Circular Depression	Unknown	1	Some Change ³
F31	4556120	289449	-29.0	35	74	0.11	Circular Depression	Unknown	1	Little Change
F32	4556120	289535	-28.8	19	26	0.05	Circular Depression	Unknown	1	Mostly Healed
F33	4556100	289519	-28.7	31	56	0.1	Circular Depression	Unknown	1	Mostly Healed
F34	4553360	286958	-22.0	195	247	0.2	Drag Mark	Unknown	1	Little Change
F35	4553420	286922	-21.8	52	70	0.1	Drag Mark	Unknown	1	Little Change
F36	4553310	287048	-21.7	146	222	0.16	Drag Mark	Unknown	1	Little Change

Notes: See Charts 3, 4, 5, and 6 for the location of each seafloor disturbance feature.

¹ UTM Zone 19, NAD83, Meter

² Elevation represents centroid location of the feature.

³ Change was infilling of feature.

⁴ Change was deepening of feature.

Feature ID	Northing ¹ (m)	Easting ¹ (m)	Elevation ² (m)	Feature Perimeter (m)	Feature Area (m ²)	Max Depth (m)	Feature Interpretation	Attributed Vessel	Construction Season	Relative Change
F37	4554690	288094	-26.3	18	22	0.1	Circular Depression	Unknown	1	Mostly Healed
F38	4554690	288098	-26.3	15	14	0.06	Circular Depression	Unknown	1	Mostly Healed
F39	4554720	288019	-26.4	20	28	0.14	Circular Depression	Unknown	1	Mostly Healed
F40	4554700	287980	-26.4	19	24	0.06	Circular Depression	Unknown	1	Mostly Healed
F41	4554830	287787	-26.8	12	11	0.1	Circular Depression	Unknown	1	Mostly Healed
F42	4554830	287846	-26.6	18	23	0.14	Circular Depression	Unknown	1	Mostly Healed
F43	4555370	289084	-27.2	25	44	0.09	Circular Depression	Unknown	1	Some Change ³
F44	4555390	289036	-27.5	21	32	0.07	Circular Depression	Unknown	1	Mostly Healed
F45	4555380	288895	-28.0	52	80	0.13	Drag Mark	Unknown	1	Little Change
F46	4555350	288826	-28.1	25	43	0.08	Circular Depression	Unknown	1	Little Change
F47	4555380	288829	-28.2	26	50	0.06	Circular Depression	Unknown	1	Mostly Healed
F48	4555460	288838	-28.5	37	76	0.07	Circular Depression	Unknown	1	Little Change
F49	4555410	288995	-27.7	28	46	0.08	Circular Depression	Unknown	1	Mostly Healed

Notes: See Charts 3, 4, 5, and 6 for the location of each seafloor disturbance feature.

¹ UTM Zone 19, NAD83, Meter

² Elevation represents centroid location of the feature.

³ Change was infilling of feature.

⁴ Change was deepening of feature.

Feature ID	Northing ¹ (m)	Easting ¹ (m)	Elevation ² (m)	Feature Perimeter (m)	Feature Area (m ²)	Max Depth (m)	Feature Interpretation	Attributed Vessel	Construction Season	Relative Change
F50	4555470	288954	-28.0	32	59	0.1	Circular Depression	Unknown	1	Little Change
F51	4555450	288905	-28.2	18	22	0.05	Circular Depression	Unknown	1	Mostly Healed
F52	4555340	289077	-27.2	33	49	0.08	Circular Depression	Unknown	1	Mostly Healed
F53	4555380	289154	-27.1	18	24	0.06	Circular Depression	Unknown	1	Mostly Healed
F54	4555470	289071	-27.8	25	43	0.09	Circular Depression	Unknown	1	Mostly Healed
F55	4555580	289074	-28.4	21	26	0.09	Circular Depression	Unknown	1	Little Change
F56	4555560	289223	-27.8	32	67	0.18	Circular Depression	Unknown	1	Some Change ³
F57	4555600	289430	-27.9	22	34	0.12	Circular Depression	Unknown	1	Mostly Healed
F58	4555420	289304	-26.8	32	76	0.17	Circular Depression	Unknown	1	Mostly Healed
F59	4555450	289541	-26.5	28	52	0.13	Circular Depression	Unknown	1	Mostly Healed
F60	4555420	289514	-26.5	29	47	0.08	Circular Depression	Unknown	1	Mostly Healed
F61	4555420	289533	-26.5	17	21	0.03	Circular Depression	Unknown	1	Mostly Healed
F62	4555470	289629	-26.5	25	44	0.08	Circular Depression	Unknown	1	Mostly Healed

Notes: See Charts 3, 4, 5, and 6 for the location of each seafloor disturbance feature.

¹ UTM Zone 19, NAD83, Meter

² Elevation represents centroid location of the feature.

³ Change was infilling of feature.

⁴ Change was deepening of feature.

Feature ID	Northing ¹ (m)	Easting ¹ (m)	Elevation ² (m)	Feature Perimeter (m)	Feature Area (m ²)	Max Depth (m)	Feature Interpretation	Attributed Vessel	Construction Season	Relative Change
F63	4555620	289412	-28.1	15	16	0.06	Circular Depression	Unknown	1	Mostly Healed
F64	4554900	289275	-25.7	27	46	0.11	Circular Depression	Unknown	1	Little Change
F65	4554940	289309	-25.6	33	78	0.09	Circular Depression	Unknown	1	Some Change ³
F66	4554920	289234	-25.7	23	38	0.06	Circular Depression	Unknown	1	Some Change ³
F67	4554850	289053	-26.4	23	37	0.14	Circular Depression	Unknown	1	Some Change ³
F68	4554820	289105	-27.0	24	38	0.2	Circular Depression	Unknown	1	Some Change ³
F69	4554950	288323	-24.3	28	57	0.1	Circular Depression	Unknown	1	Mostly Healed
F70	4554900	288294	-24.4	24	35	0.1	Circular Depression	Unknown	1	Mostly Healed
F71	4554870	288253	-24.6	25	42	0.06	Circular Depression	Unknown	1	Mostly Healed
F72	4554830	288332	-25.0	27	51	0.11	Circular Depression	Unknown	1	Mostly Healed
F73	4554190	288330	-24.6	21	31	0.07	Circular Depression	Unknown	1	Little Change
F74	4554220	288352	-24.4	24	41	0.05	Circular Depression	Unknown	1	Some Change ³
F75	4554800	288452	-25.4	43	106	0.09	Drag Mark	Unknown	1	Mostly Healed

Notes: See Charts 3, 4, 5, and 6 for the location of each seafloor disturbance feature.

¹ UTM Zone 19, NAD83, Meter

² Elevation represents centroid location of the feature.

³ Change was infilling of feature.

⁴ Change was deepening of feature.

Feature ID	Northing ¹ (m)	Easting ¹ (m)	Elevation ² (m)	Feature Perimeter (m)	Feature Area (m ²)	Max Depth (m)	Feature Interpretation	Attributed Vessel	Construction Season	Relative Change
F76	4555080	288517	-25.6	41	64	0.25	Drag Mark	Unknown	1	Mostly Healed
F77	4555740	289474	-28.1	64	89	0.07	Drag Mark	Unknown	1	Mostly Healed
F78	4554100	287659	-26.2	70	135	0.22	Scour	Unknown	1	Mostly Healed
F79	4555170	288618	-26.6	24	38	0.08	Circular Depression	Unknown	1	Mostly Healed
F80	4554590	288327	-26.2	17	19	0.07	Circular Depression	Unknown	1	Mostly Healed
F81	4554090	287646	-26.0	36	79	0.08	Scour	Unknown	1	Little Change
F82	4555740	289545	-27.8	33	80	0.1	Spud	L/B Robert	1	Little Change
F83	4555050	288622	-25.7	27	51	0.05	Circular Depression	Unknown	1	Mostly Healed
F84	4554920	288672	-25.6	25	45	0.05	Circular Depression	Unknown	1	Mostly Healed
F85	4554240	288261	-24.9	24	36	0.06	Circular Depression	Unknown	1	Mostly Healed
F86	4554790	289218	-26.7	22	32	0.08	Circular Depression	Unknown	1	Mostly Healed
F87	4554780	288338	-25.3	33	82	0.09	Circular Depression	Unknown	1	Mostly Healed
F88	4554830	288386	-24.8	31	68	0.05	Circular Depression	Unknown	1	Mostly Healed

Notes: See Charts 3, 4, 5, and 6 for the location of each seafloor disturbance feature.

¹ UTM Zone 19, NAD83, Meter

² Elevation represents centroid location of the feature.

³ Change was infilling of feature.

⁴ Change was deepening of feature.

Feature ID	Northing ¹ (m)	Easting ¹ (m)	Elevation ² (m)	Feature Perimeter (m)	Feature Area (m ²)	Max Depth (m)	Feature Interpretation	Attributed Vessel	Construction Season	Relative Change
F89	4554540	288325	-23.8	27	53	0.08	Scour	Unknown	1	Little Change
F90	4554840	288214	-25.0	33	69	0.08	Circular Depression	Unknown	1	Mostly Healed
F91	4553920	286779	-22.0	23	39	0.12	Circular Depression	Unknown	1	Little Change
F92	4555700	289557	-27.5	25	47	0.12	Spud	L/B Robert	1	Mostly Healed
F93	4554590	288330	-26.3	22	32	0.07	Circular Depression	Unknown	1	Mostly Healed
F94	4554560	288311	-26.1	31	71	0.06	Scour	Unknown	1	Little Change
F95	4555760	289539	-27.8	37	99	0.13	Spud	L/B Robert	1	Mostly Healed
F96	4555720	289520	-27.9	28	56	0.16	Spud	L/B Robert	1	Some Change ⁴
F97	4555780	289517	-28.0	36	94	0.16	Spud	L/B Robert	1	Little Change
F98	4555750	289472	-28.2	24	43	0.15	Spud	L/B Robert	1	Mostly Healed
F99	4555790	289456	-28.4	21	32	0.19	Spud	L/B Robert	1	Mostly Healed
F100	4555770	289493	-28.2	27	51	0.11	Spud	L/B Robert	1	Mostly Healed

∞

Notes: See Charts 3, 4, 5, and 6 for the location of each seafloor disturbance feature.

¹ UTM Zone 19, NAD83, Meter

² Elevation represents centroid location of the feature.

³ Change was infilling of feature.

⁴ Change was deepening of feature.

Feature ID	Northing ¹ (m)	Easting ¹ (m)	Elevation ² (m)	Feature Perimeter (m)	Feature Area (m ²)	Max Depth (m)	Feature Interpretation	Attributed Vessel	Construction Season	Relative Change
F101	4555730	289481	-28.3	32	62	0.38	Spud	L/B Michael Eymard	1	Mostly Healed
F102	4555130	288971	-26.8	21	30	0.1	Spud	L/B Robert	1	Mostly Healed
F103	4555720	289486	-28.1	17	19	0.15	Spud	L/B Michael Eymard	1	Mostly Healed
F104	4555720	289495	-28.2	18	19	0.33	Spud	L/B Michael Eymard	1	Mostly Healed
F105	4555730	289499	-28.1	17	17	0.20	Spud	L/B Michael Eymard	1	Mostly Healed
F106	4555730	289491	-28.3	14	12	0.20	Spud	L/B Michael Eymard	1	Mostly Healed
F107	4555730	289488	-28.2	19	21	0.20	Spud	L/B Michael Eymard	1	Mostly Healed
F108	4555700	289477	-28.0	19	21	0.14	Spud	L/B Michael Eymard	1	Mostly Healed
F109	4555700	289470	-28.1	19	19	0.15	Spud	L/B Michael Eymard	1	Mostly Healed

Notes: See Charts 3, 4, 5, and 6 for the location of each seafloor disturbance feature.

¹ UTM Zone 19, NAD83, Meter

² Elevation represents centroid location of the feature.

³ Change was infilling of feature.

⁴ Change was deepening of feature.

Feature ID	Northing ¹ (m)	Easting ¹ (m)	Elevation ² (m)	Feature Perimeter (m)	Feature Area (m ²)	Max Depth (m)	Feature Interpretation	Attributed Vessel	Construction Season	Relative Change
F110	4555130	288947	-26.7	28	55	0.06	Scour	Unknown	1	Little Change
F111	4555150	288948	-26.8	21	34	0.1	Spud	L/B Robert	1	Little Change
F112	4555170	288984	-26.9	21	34	0.07	Spud	L/B Robert	1	Mostly Healed
F113	4555110	288930	-26.6	40	99	0.11	Scour	Unknown	1	Little Change
F114	4555090	288927	-26.5	23	35	0.13	Spud	L/B Michael Eymard	1	Mostly Healed
F115	4555080	288943	-26.5	22	32	0.12	Spud	L/B Michael Eymard	1	Mostly Healed
F116	4555060	288925	-26.4	15	15	0.12	Spud	L/B Michael Eymard	1	Mostly Healed
F117	4554090	287674	-25.9	30	45	0.08	Scour	Unknown	1	Mostly Healed
F118	4554090	287670	-25.9	20	20	0.06	Scour	Unknown	1	Mostly Healed
F119	4554080	287682	-25.9	24	32	0.06	Scour	Unknown	1	Mostly Healed
F120	4554070	287663	-26.0	33	75	0.04	Scour	Unknown	1	Little Change

Notes: See Charts 3, 4, 5, and 6 for the location of each seafloor disturbance feature.

¹ UTM Zone 19, NAD83, Meter

² Elevation represents centroid location of the feature.

³ Change was infilling of feature.

⁴ Change was deepening of feature.

Feature ID	Northing ¹ (m)	Easting ¹ (m)	Elevation ² (m)	Feature Perimeter (m)	Feature Area (m ²)	Max Depth (m)	Feature Interpretation	Attributed Vessel	Construction Season	Relative Change
F121	4554060	287630	-26.0	12	11	0.12	Scour	Unknown	1	Mostly Healed
F122	4555750	289524	-23.7	31	66	0.1	Scour	Unknown	1	Some Change ³
F123	4555770	289508	-28.0	32	78	0.06	Scour	Unknown	1	Some Change ³
F124	4555750	289491	-25.4	36	99	0.07	Scour	Unknown	1	Some Change ³
F125	4555730	289508	-28.0	33	65	0.08	Scour	Unknown	1	Some Change ³
F126	4555110	288964	-26.6	30	62	0.02	Scour	Unknown	1	Little Change
F127	4555100	288947	-18.7	25	47	0.03	Scour	Unknown	1	Little Change
F128	4554570	288324	-13.8	37	98	0.06	Scour	Unknown	1	Some Change ³
F129	4554560	288339	-26.0	25	42	0.03	Scour	Unknown	1	Little Change
F130	4554070	287634	-17.7	43	90	0.12	Scour	Unknown	1	Some Change ³
F131	4554050	287648	-26.0	32	52	0.05	Scour	Unknown	1	Some Change ³
F132	4553650	286914	-18.9	21	32	0.05	Scour	Unknown	1	Some Change ³
F133	4553670	286929	-23.6	16	18	0.09	Scour	Unknown	1	Some Change ³

Notes: See Charts 3, 4, 5, and 6 for the location of each seafloor disturbance feature.

¹ UTM Zone 19, NAD83, Meter

² Elevation represents centroid location of the feature.

³ Change was infilling of feature.

⁴ Change was deepening of feature.

Feature ID	Northing ¹ (m)	Easting ¹ (m)	Elevation ² (m)	Feature Perimeter (m)	Feature Area (m ²)	Max Depth (m)	Feature Interpretation	Attributed Vessel	Construction Season	Relative Change
F134	4553670	286899	-23.3	19	22	0.1	Scour	Unknown	1	Some Change ³
F135	4553680	286913	-19.2	24	38	0.02	Scour	Unknown	1	Some Change ³
F136	4553280	287071	-21.7	93	155	0.05	Drag Mark	Unknown	1	Little Change
F137	4553290	287037	-21.1	58	65	0.1	Drag Mark	Unknown	1	Some Change ³
F138	4555090	288255	-25.3	48	40	0.09	Drag Mark	Unknown	1	Mostly Healed
F139	4555090	288225	-25.1	91	60	0.06	Drag Mark	Unknown	1	Mostly Healed
F140	4555030	288476	-25.1	86	34	0.06	Drag Mark	Unknown	1	Mostly Healed
F141	4554580	288290	-26.1	68	30	0.03	Drag Mark	Unknown	1	Mostly Healed
F142	4554580	288317	-26.2	53	19	0.06	Drag Mark	Unknown	1	Mostly Healed
F143	4554380	287514	-26.3	76	69	0.11	Drag Mark	Unknown	1	Some Change ³
F144	4554070	287607	-26.0	164	176	0.02	Drag Mark	Unknown	1	Mostly Healed
F145	4554090	287595	-26.1	146	131	0.02	Drag Mark	Unknown	1	Mostly Healed
F146	4554120	287565	-26.1	112	109	0.02	Drag Mark	Unknown	1	Mostly Healed

Notes: See Charts 3, 4, 5, and 6 for the location of each seafloor disturbance feature.

¹ UTM Zone 19, NAD83, Meter

² Elevation represents centroid location of the feature.

³ Change was infilling of feature.

⁴ Change was deepening of feature.

Feature ID	Northing ¹ (m)	Easting ¹ (m)	Elevation ² (m)	Feature Perimeter (m)	Feature Area (m ²)	Max Depth (m)	Feature Interpretation	Attributed Vessel	Construction Season	Relative Change
F147	4554050	287615	-26.0	272	292	0.03	Drag Mark	Unknown	1	Mostly Healed
F148	4553990	287487	-26.3	142	121	0.02	Drag Mark	Unknown	1	Mostly Healed
F149	4553990	287423	-26.1	291	225	0.05	Drag Mark	Unknown	1	Mostly Healed
F150	4553930	286775	-22.1	141	151	0.08	Drag Mark	Unknown	1	Some Change ³
F151	4553990	286768	-22.9	29	39	0.21	Drag Mark	Unknown	1	Some Change ³
F152	4554020	286959	-24.2	13	12	0.15	Circular Depression	Unknown	1	Mostly Healed
F153	4553510	287184	-23.3	10	7	0.12	Circular Depression	Unknown	1	Mostly Healed
F154	4554140	287279	-25.8	28	41	0.07	Drag Mark	Unknown	1	Some Change ³
F155	4554640	287558	-27.0	16	18	0.12	Circular Depression	Unknown	1	Mostly Healed
F156	4554330	287759	-26.1	12	9	0.20	Circular Depression	Unknown	1	Mostly Healed
F157	4554320	287709	-26.0	16	18	0.10	Circular Depression	Unknown	1	Mostly Healed
F158	4556180	289764	-28.0	161	129	0.02	Drag Mark	Unknown	1	Mostly Healed
F159	4556180	289793	-28.0	90	63	0.03	Drag Mark	Unknown	1	Mostly Healed

Notes: See Charts 3, 4, 5, and 6 for the location of each seafloor disturbance feature.

¹ UTM Zone 19, NAD83, Meter

² Elevation represents centroid location of the feature.

³ Change was infilling of feature.

⁴ Change was deepening of feature.

Feature ID	Northing ¹ (m)	Easting ¹ (m)	Elevation ² (m)	Feature Perimeter (m)	Feature Area (m ²)	Max Depth (m)	Feature Interpretation	Attributed Vessel	Construction Season	Relative Change
F160	4555720	289530	-28.4	54	196	0.60	Spud	L/B <i>Brave Tern</i>	2	Little Change
F161	4555700	289552	-28.6	58	246	1.2	Spud	L/B <i>Brave Tern</i>	2	Little Change
F162	4555750	289601	-28.3	58	245	0.90	Spud	L/B <i>Brave Tern</i>	2	Little Change
F163	4555770	289579	-28.5	52	187	0.87	Spud	L/B <i>Brave Tern</i>	2	Little Change
F164	4555070	288987	-27.5	56	214	0.90	Spud	L/B <i>Brave Tern</i>	2	Some Change ³
F165	4555110	289037	-27.3	46	148	0.60	Spud	L/B <i>Brave Tern</i>	2	Mostly Healed
F166	4555130	289017	-27.4	50	170	0.85	Spud	L/B <i>Brave Tern</i>	2	Some Change ³
F167	4555090	288966	-27.3	51	185	0.86	Spud	L/B <i>Brave Tern</i>	2	Some Change ³
F168	4554510	288367	-26.4	57	222	0.85	Spud	L/B <i>Brave Tern</i>	2	Mostly Healed
F169	4554560	288417	-27.0	67	313	1.27	Spud	L/B <i>Brave Tern</i>	2	Mostly Healed
F170	4554580	288397	-26.8	54	213	0.75	Spud	L/B <i>Brave Tern</i>	2	Mostly Healed
F171	4554530	288345	-26.8	59	255	1.16	Spud	L/B <i>Brave Tern</i>	2	Mostly Healed
F172	4554070	287741	-25.8	50	191	0.62	Spud	L/B <i>Brave Tern</i>	2	Little Change

Notes: See Charts 3, 4, 5, and 6 for the location of each seafloor disturbance feature.

¹ UTM Zone 19, NAD83, Meter

² Elevation represents centroid location of the feature.

³ Change was infilling of feature.

⁴ Change was deepening of feature.

Feature ID	Northing ¹ (m)	Easting ¹ (m)	Elevation ² (m)	Feature Perimeter (m)	Feature Area (m ²)	Max Depth (m)	Feature Interpretation	Attributed Vessel	Construction Season	Relative Change
F173	4554090	287720	-25.7	49	174	0.75	Spud	L/B <i>Brave Tern</i>	2	Little Change
F174	4554050	287669	-26.5	48	160	0.75	Spud	L/B <i>Brave Tern</i>	2	Mostly Healed
F175	4554030	287690	-26.4	48	164	0.75	Spud	L/B <i>Brave Tern</i>	2	Mostly Healed
F176	4553670	287009	-24.2	41	124	0.14	Spud	L/B <i>Brave Tern</i>	2	Mostly Healed
F177	4553690	286988	-24.3	45	150	0.30	Spud	L/B <i>Brave Tern</i>	2	Mostly Healed
F178	4553620	286958	-23.2	41	124	0.06	Spud	L/B <i>Brave Tern</i>	2	Mostly Healed
F179	4553640	286937	-23.4	38	110	0.09	Spud	L/B <i>Brave Tern</i>	2	Mostly Healed
F180	4553870	287675	-25.5	47	68	0.10	Drag Mark	Unknown	2	Mostly Healed
F181	4554820	289162	-26.7	16	19	0.12	Circular Depression	Unknown	2	Mostly Healed
F182	4554830	289135	-26.6	15	15	0.10	Circular Depression	Unknown	2	Mostly Healed
F183	4554840	289150	-26.4	12	10	0.07	Circular Depression	Unknown	2	Mostly Healed
F184	4554790	289089	-27.2	59	84	0.08	Drag Mark	Unknown	2	Mostly Healed
F185	4555100	288885	-26.6	21	30	0.08	Circular Depression	Unknown	2	Mostly Healed

Notes: See Charts 3, 4, 5, and 6 for the location of each seafloor disturbance feature.

¹ UTM Zone 19, NAD83, Meter

² Elevation represents centroid location of the feature.

³ Change was infilling of feature.

⁴ Change was deepening of feature.

Feature ID	Northing ¹ (m)	Easting ¹ (m)	Elevation ² (m)	Feature Perimeter (m)	Feature Area (m ²)	Max Depth (m)	Feature Interpretation	Attributed Vessel	Construction Season	Relative Change
F186	4555120	288881	-26.7	17	19	0.09	Circular Depression	Unknown	2	Mostly Healed
F187	4555210	288894	-27.4	16	19	0.09	Circular Depression	Unknown	2	Mostly Healed
F188	4555200	288876	-27.3	13	13	0.03	Circular Depression	Unknown	2	Mostly Healed
F189	4555190	288919	-27.1	14	14	0.05	Circular Depression	Unknown	2	Mostly Healed
F190	4555180	288904	-27.1	15	15	0.07	Circular Depression	Unknown	2	Mostly Healed
F191	4555220	289063	-27.0	12	9	0.09	Circular Depression	Unknown	2	Mostly Healed
F192	4555420	289116	-27.3	76	61	0.06	Drag Mark	Unknown	2	Mostly Healed
F193	4555440	289142	-27.4	145	107	0.06	Drag Mark	Unknown	2	Mostly Healed
F194	4555450	289665	-27.1	35	69	0.08	Circular Depression	Unknown	2	Mostly Healed
F195	4555450	289725	-27.2	21	28	0.06	Circular Depression	Unknown	2	Mostly Healed
F196	4555480	289713	-27.1	21	30	0.06	Circular Depression	Unknown	2	Mostly Healed
F197	4555460	289698	-27.1	21	33	0.06	Circular Depression	Unknown	2	Mostly Healed
F198	4555630	289501	-27.5	15	16	0.11	Circular Depression	Unknown	2	Mostly Healed

Notes: See Charts 3, 4, 5, and 6 for the location of each seafloor disturbance feature.

¹ UTM Zone 19, NAD83, Meter

² Elevation represents centroid location of the feature.

³ Change was infilling of feature.

⁴ Change was deepening of feature.

Feature ID	Northing ¹ (m)	Easting ¹ (m)	Elevation ² (m)	Feature Perimeter (m)	Feature Area (m ²)	Max Depth (m)	Feature Interpretation	Attributed Vessel	Construction Season	Relative Change
F199	4555640	289514	-27.4	16	18	0.13	Circular Depression	Unknown	2	Mostly Healed
F200	4555650	289499	-27.5	11	8	0.06	Circular Depression	Unknown	2	Mostly Healed
F201	4555650	289482	-27.8	27	49	0.16	Circular Depression	Unknown	2	Some Change ³
F202	4555660	289489	-27.6	13	10	0.06	Circular Depression	Unknown	2	Mostly Healed
F203	4555640	289477	-27.6	27	25	0.07	Drag Mark	Unknown	2	Mostly Healed
F204	4555650	289522	-27.4	9	6	0.05	Circular Depression	Unknown	2	Mostly Healed
F205	4555660	289519	-27.4	10	7	0.07	Circular Depression	Unknown	2	Mostly Healed
F206	4555670	289505	-27.6	11	8	0.07	Circular Depression	Unknown	2	Mostly Healed
F207	4555670	289500	-27.6	11	8	0.06	Circular Depression	Unknown	2	Mostly Healed
F208	4555670	289487	-27.8	16	18	0.11	Circular Depression	Unknown	2	Mostly Healed
F209	4555120	288971	-26.7	15	15	0.04	Spud	L/B <i>Michael Eymard</i>	2	Mostly Healed
F210	4555130	288968	-26.7	15	15	0.09	Spud	L/B <i>Michael Eymard</i>	2	Mostly Healed

Notes: See Charts 3, 4, 5, and 6 for the location of each seafloor disturbance feature.

¹ UTM Zone 19, NAD83, Meter

² Elevation represents centroid location of the feature.

³ Change was infilling of feature.

⁴ Change was deepening of feature.

Feature ID	Northing ¹ (m)	Easting ¹ (m)	Elevation ² (m)	Feature Perimeter (m)	Feature Area (m ²)	Max Depth (m)	Feature Interpretation	Attributed Vessel	Construction Season	Relative Change
F211	4555130	288958	-26.8	18	22	0.10	Spud	L/B <i>Michael Eymard</i>	2	Mostly Healed
F212	4555140	288954	-26.9	25	44	0.17	Spud	L/B <i>Michael Eymard</i>	2	Mostly Healed
F213	4555150	288987	-26.8	21	33	0.07	Spud	L/B <i>Michael Eymard</i>	2	Some Change ³
F214	4555140	288952	-26.8	31	37	0.05	Circular Depression	Unknown	2	Mostly Healed
F215	4554870	288574	-25.6	27	28	0.08	Drag Mark	Unknown	2	Mostly Healed
F216	4554830	288547	-25.9	24	19	0.06	Drag Mark	Unknown	2	Mostly Healed
F217	4555680	289482	-27.8	33	62	0.13	Circular Depression	Unknown	2	Little Change
F218	4555690	289501	-27.7	22	37	0.13	Circular Depression	Unknown	2	Mostly Healed
F219	4555690	289497	-27.8	31	43	0.10	Circular Depression	Unknown	2	Mostly Healed
F220	4555660	289515	-27.5	20	28	0.14	Circular Depression	Unknown	2	Mostly Healed
F221	4555660	289509	-27.6	24	41	0.15	Circular Depression	Unknown	2	Little Change

Notes: See Charts 3, 4, 5, and 6 for the location of each seafloor disturbance feature.

¹ UTM Zone 19, NAD83, Meter

² Elevation represents centroid location of the feature.

³ Change was infilling of feature.

⁴ Change was deepening of feature.

Feature ID	Northing ¹ (m)	Easting ¹ (m)	Elevation ² (m)	Feature Perimeter (m)	Feature Area (m ²)	Max Depth (m)	Feature Interpretation	Attributed Vessel	Construction Season	Relative Change
F222	4555850	289591	-27.8	17	14	0.11	Circular Depression	Unknown	2	Mostly Healed
F223	4555860	289598	-27.8	11	9	0.09	Circular Depression	Unknown	2	Mostly Healed
F224	4555870	289592	-27.9	12	10	0.06	Circular Depression	Unknown	2	Mostly Healed
F225	4555870	289585	-27.9	7	3	0.03	Circular Depression	Unknown	2	Mostly Healed
F226	4555870	289464	-28.6	20	27	0.10	Circular Depression	Unknown	2	Mostly Healed
F227	4555850	289491	-28.5	21	26	0.16	Circular Depression	Unknown	2	Mostly Healed
F228	4555820	289428	-28.7	20	23	0.15	Circular Depression	Unknown	2	Mostly Healed
F229	4555730	289398	-28.4	28	30	0.05	Drag Mark	Unknown	2	Mostly Healed
F230	4555760	289426	-28.4	17	20	0.08	Circular Depression	Unknown	2	Mostly Healed
F231	4555780	289517	-28.0	17	18	0.12	Spud	L/B <i>Michael Eymard</i>	2	Mostly Healed
F232	4555770	289518	-28.0	17	22	0.07	Spud	L/B <i>Michael Eymard</i>	2	Mostly Healed

Notes: See Charts 3, 4, 5, and 6 for the location of each seafloor disturbance feature.

¹ UTM Zone 19, NAD83, Meter

² Elevation represents centroid location of the feature.

³ Change was infilling of feature.

⁴ Change was deepening of feature.

Feature ID	Northing ¹ (m)	Easting ¹ (m)	Elevation ² (m)	Feature Perimeter (m)	Feature Area (m ²)	Max Depth (m)	Feature Interpretation	Attributed Vessel	Construction Season	Relative Change
F233	4555780	289523	-28.0	14	13	0.05	Spud	L/B <i>Michael Eymard</i>	2	Mostly Healed
F234	4555770	289523	-27.9	16	17	0.04	Spud	L/B <i>Michael Eymard</i>	2	Mostly Healed
F235	4555760	289532	-27.8	16	17	0.09	Spud	L/B <i>Michael Eymard</i>	2	Mostly Healed
F236	4555760	289538	-27.9	25	44	0.11	Spud	L/B <i>Michael Eymard</i>	2	Mostly Healed
F237	4555770	289532	-27.9	19	24	0.11	Spud	L/B <i>Michael Eymard</i>	2	Mostly Healed
F238	4555770	289528	-27.8	15	16	0.04	Spud	L/B <i>Michael Eymard</i>	2	Mostly Healed
F239	4555790	289544	-27.9	12	10	0.05	Spud	L/B <i>Michael Eymard</i>	2	Mostly Healed
F240	4555790	289551	-27.9	19	23	0.12	Spud	L/B <i>Michael Eymard</i>	2	Mostly Healed

Notes: See Charts 3, 4, 5, and 6 for the location of each seafloor disturbance feature.

¹ UTM Zone 19, NAD83, Meter

² Elevation represents centroid location of the feature.

³ Change was infilling of feature.

⁴ Change was deepening of feature.

Feature ID	Northing ¹ (m)	Easting ¹ (m)	Elevation ² (m)	Feature Perimeter (m)	Feature Area (m ²)	Max Depth (m)	Feature Interpretation	Attributed Vessel	Construction Season	Relative Change
F241	4555790	289545	-27.9	16	17	0.06	Spud	L/B <i>Michael Eymard</i>	2	Mostly Healed
F242	4555790	289550	-27.9	14	14	0.05	Spud	L/B <i>Michael Eymard</i>	2	Mostly Healed
F243	4555780	289543	-27.9	37	48	0.08	Drag Mark	Unknown	2	Mostly Healed
F244	4555440	288879	-28.2	24	41	0.08	Circular Depression	Unknown	2	Mostly Healed
F245	4555310	288352	-27.6	178	169	0.08	Drag Mark	Unknown	2	Mostly Healed
F246	4554090	287652	-26.4	44	145	0.41	Circular Depression	Unknown	2	Mostly Healed
F247	4554090	287663	-26.3	37	100	0.41	Circular Depression	Unknown	2	Mostly Healed
F248	4554080	287671	-26.1	35	82	0.11	Circular Depression	Unknown	2	Mostly Healed
F249	4554080	287678	-25.9	30	63	0.10	Circular Depression	Unknown	2	Mostly Healed
F250	4553980	287650	-25.9	32	72	0.17	Circular Depression	Unknown	2	Mostly Healed
F251	4553990	287625	-25.8	27	51	0.25	Circular Depression	Unknown	2	Mostly Healed
F252	4554440	286955	-27.4	112	80	0.13	Drag Mark	Unknown	2	Mostly Healed

Notes: See Charts 3, 4, 5, and 6 for the location of each seafloor disturbance feature.

¹ UTM Zone 19, NAD83, Meter

² Elevation represents centroid location of the feature.

³ Change was infilling of feature.

⁴ Change was deepening of feature.

Feature ID	Northing ¹ (m)	Easting ¹ (m)	Elevation ² (m)	Feature Perimeter (m)	Feature Area (m ²)	Max Depth (m)	Feature Interpretation	Attributed Vessel	Construction Season	Relative Change
F253	4554650	287927	-26.3	25	39	0.07	Circular Depression	Unknown	2	Mostly Healed
F254	4555760	289455	-28.3	28	50	0.13	Circular Depression	Unknown	2	Mostly Healed
F255	4555800	289452	-28.4	25	32	0.13	Circular Depression	Unknown	2	Mostly Healed
F256	4555840	289479	-28.4	26	36	0.08	Circular Depression	Unknown	2	Mostly Healed
F257	4555290	289165	-26.8	34	36	0.04	Drag Mark	Unknown	2	Mostly Healed
F258	4554880	289095	-26.2	15	16	0.08	Circular Depression	Unknown	2	Little Change
F259	4554900	289079	-26.2	13	13	0.06	Circular Depression	Unknown	2	Mostly Healed
F260	455800	289404	-28.6	333	376	0.27	Drag Mark	Unknown	2	Mostly Healed
F261	4555730	289515	-27.9	19	20	0.09	Scour	Unknown	2	Mostly Healed
F262	4555740	289531	-27.8	24	31	0.12	Scour	Unknown	2	Mostly Healed
F263	4555840	289507	-28.3	60	55	0.13	Scour	N/A	Post-Construction	Little Change
F264	4555820	289487	-28.3	222	219	0.20	Scour	N/A	Post-Construction	Little Change
F265	4555740	289475	-28.1	122	112	0.19	Scour	N/A	Post-Construction	Some Change ³

Notes: See Charts 3, 4, 5, and 6 for the location of each seafloor disturbance feature.

¹ UTM Zone 19, NAD83, Meter

² Elevation represents centroid location of the feature.

³ Change was infilling of feature.

⁴ Change was deepening of feature.

Feature ID	Northing ¹ (m)	Easting ¹ (m)	Elevation ² (m)	Feature Perimeter (m)	Feature Area (m ²)	Max Depth (m)	Feature Interpretation	Attributed Vessel	Construction Season	Relative Change
F266	4555790	289475	-28.1	33	21	0.09	Scour	N/A	Post-Construction	Little Change
F267	4555760	289483	-28.2	30	25	0.10	Scour	N/A	Post-Construction	Some Change ³
F268	4555740	289482	-28.2	47	30	0.10	Scour	N/A	Post-Construction	Little Change
F269	4555710	289445	-28.2	13	11	0.08	Scour	N/A	Post-Construction	Some Change ³
F270	4555150	288908	-26.9	199	154	0.20	Scour	N/A	Post-Construction	Little Change
F271	4555160	288915	-27.0	84	53	0.07	Scour	N/A	Post-Construction	Little Change
F272	4555120	288920	-26.7	33	29	0.14	Scour	N/A	Post-Construction	Little Change
F273	4555100	288911	-26.6	81	86	0.17	Scour	N/A	Post-Construction	Little Change
F274	4555100	288918	-26.6	60	50	0.15	Scour	N/A	Post-Construction	Little Change
F275	4554192	288755	-24.6	64	70	0.20	Drag Mark	N/A	Post-Construction	Mostly Healed

Notes: See Charts 3, 4, 5, and 6 for the location of each seafloor disturbance feature.

¹ UTM Zone 19, NAD83, Meter

² Elevation represents centroid location of the feature.

³ Change was infilling of feature.

⁴ Change was deepening of feature.

D. TYPICAL CONSTRUCTION DRAWINGS

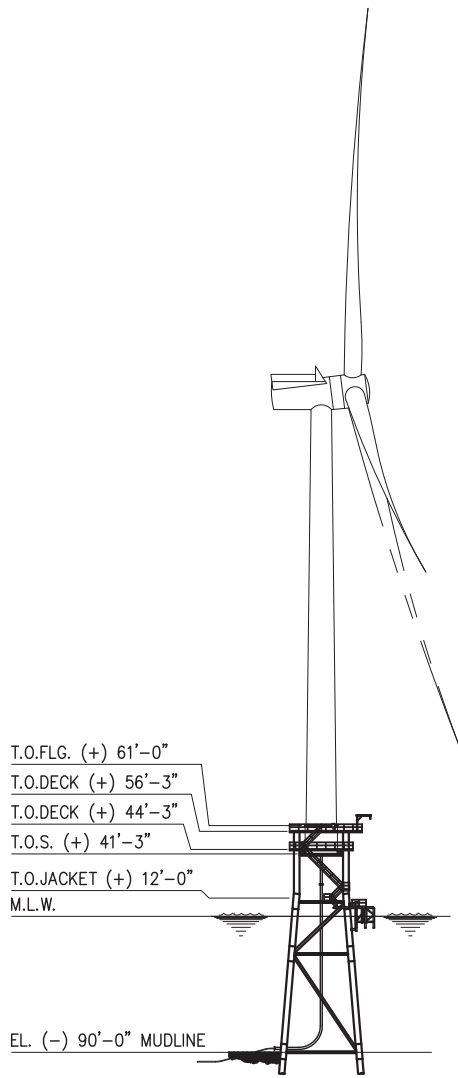

ELEVATION

<p>Upstream Engineering LLC "Providing Value Added Engineering Services" HOUSTON, TEXAS www.upstreamengineering.com (281) 531-0047</p>				<p>DEEPWATERWIND®</p>			
<p>Registration No.: F-2752</p>				<p>ASSEMBLY ELEVATION TURBINE & PLATFORM</p>			
B	03/15/12	REVISED ISSUED FOR PERMITTING	JR	RS			
A	01/24/12	ISSUED FOR PERMITTING	JR	RS			
No.	DATE	REVISION	BY	APP.			
DESIGNED BY: D. YBARRA		SCALE: 1/128"=1'-0"		PROJ. No.: P12-002			
DRAWN BY: J. RHAME		DATE: 01/11/12		FILENAME: 9001.dwg		REV. No.: B	

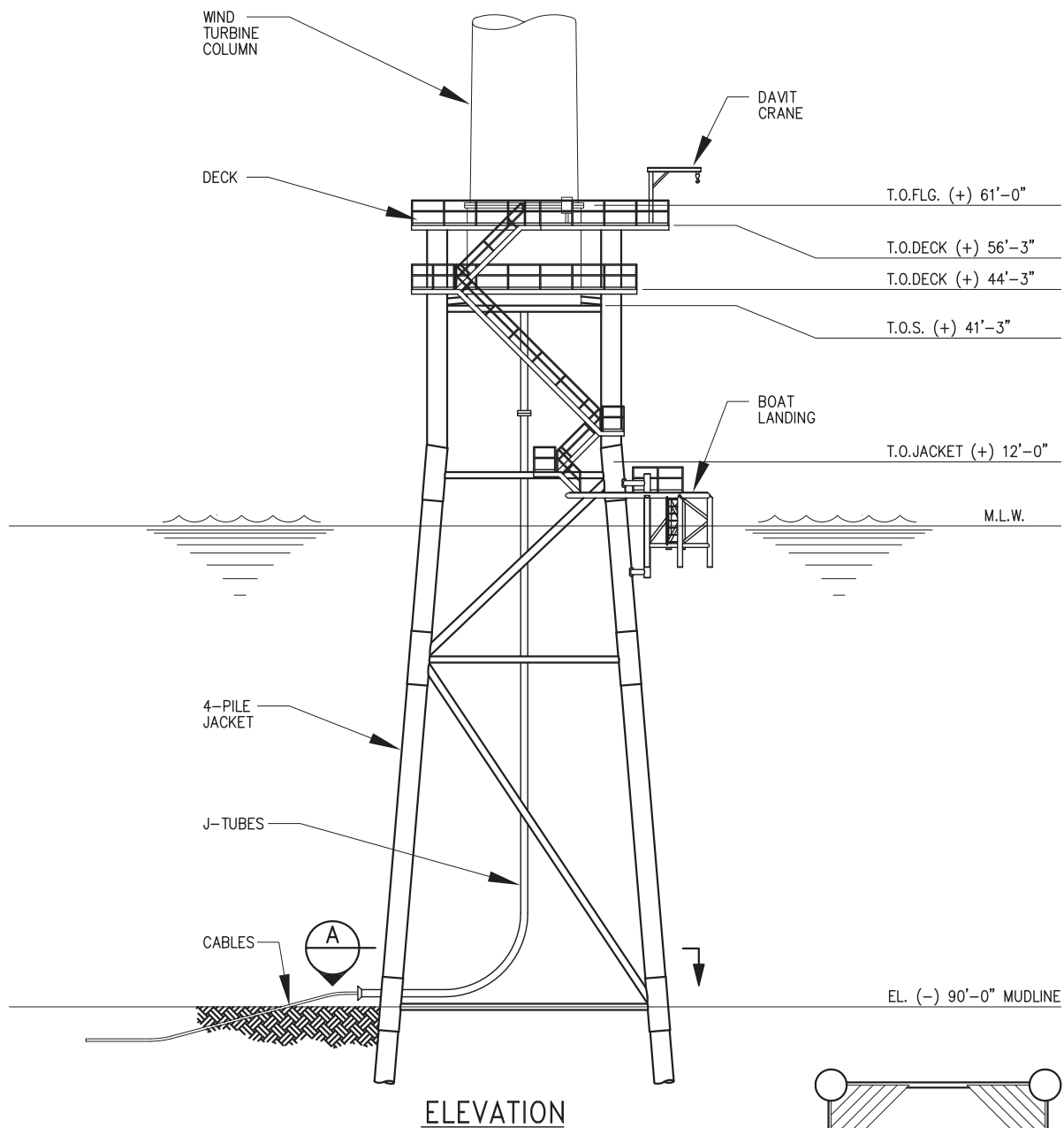

ELEVATION

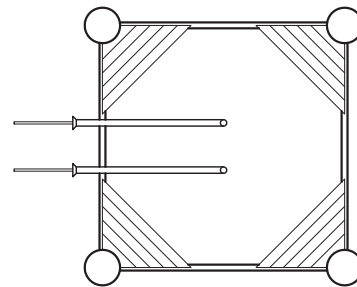

SECTION

SCALE 1"=40'-0"



Upstream Engineering LLC

"Providing Value Added Engineering Services"
HOUSTON, TEXAS www.upstreamengineering.com (281) 531-0047

Registration No.: F-2752



4-PILE JACKET w/DECK STRUCTURE

No.	DATE	REVISION	BY	APP.
C		REVISED ISSUED FOR PERMITTING	JR	
B	03/15/12	REVISED ISSUED FOR PERMITTING	JR	RS

DESIGNED BY: D. YBARRA SCALE: 1/32"=1'-0"

DRAWN BY: J. RHAME DATE: 01/11/12

PROJ. No.: P12-002
FILENAME: 9002.dwg

Figure 2

REV. No.: C

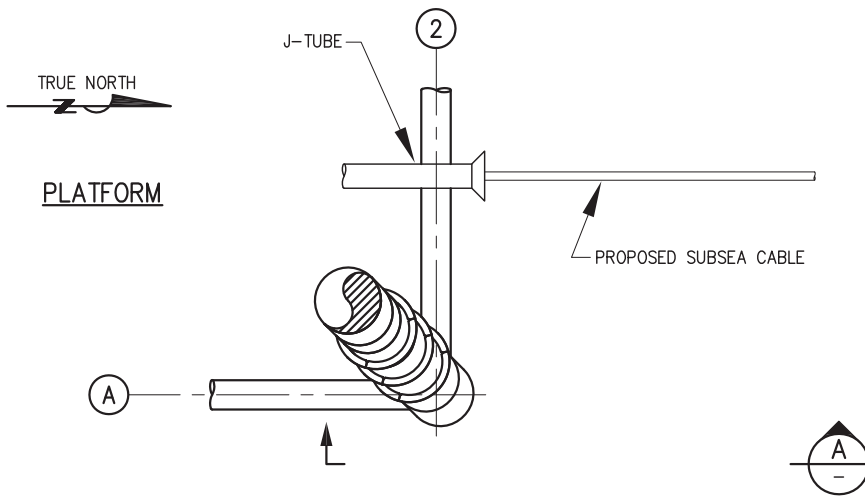

DETAIL 1
 SCALE — 3/16"=1'-0"

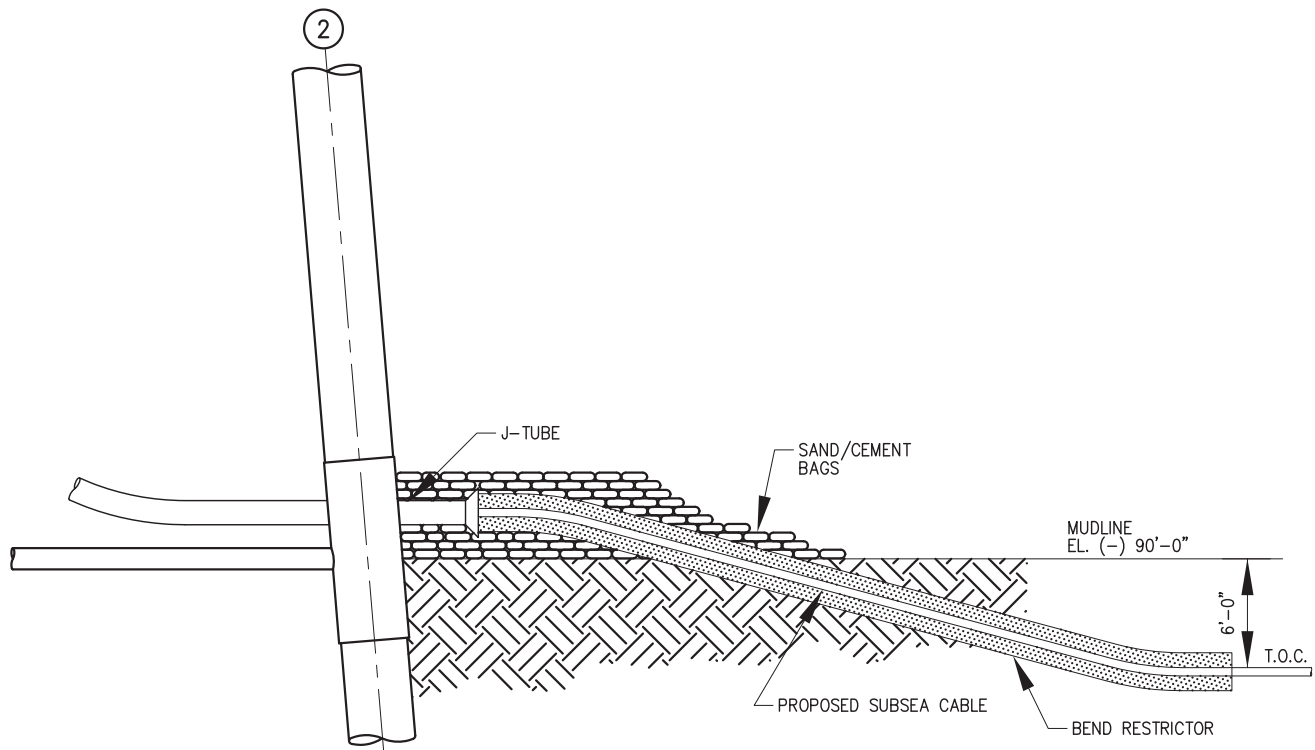

ELEVATION A
 SCALE — 3/16"=1'-0"

Upstream Engineering LLC
 "Providing Value Added Engineering Services"
 HOUSTON, TEXAS www.upstreamengineering.com (281) 531-0047

Registration No.: F-2752

No.	DATE	REVISION	BY	APP.
B	03/15/12	REVISED ISSUED FOR PERMITTING	JR	RS
A	01/24/12	ISSUED FOR PERMITTING	JR	RS

DESIGNED BY: D. YBARRA SCALE: AS NOTED

DRAWN BY: J. RHAME DATE: 01/11/12



DEEPWATERWIND®

CABLE AT J-TUBE

PROJ. No.: P12-002

FILENAME: 9009.dwg

Figure 3

REV. No.: **B**

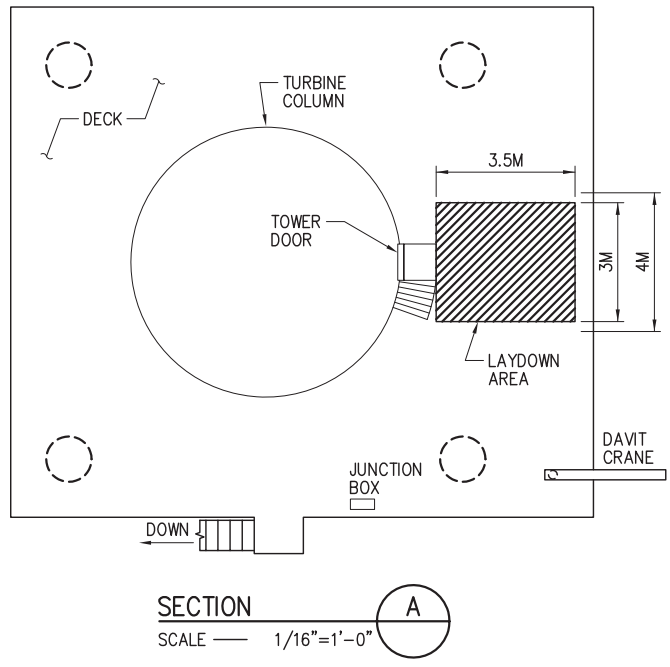
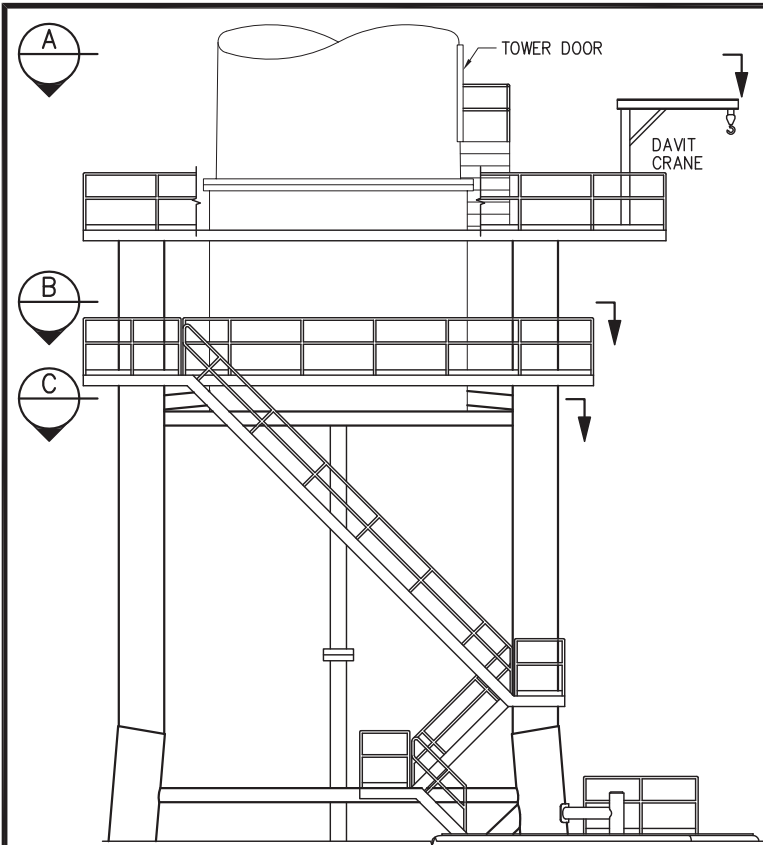

DETAIL 1
SCALE 1/16"=1'-0"

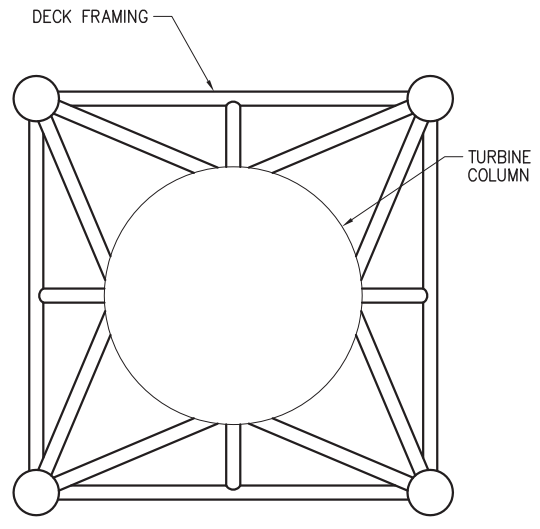
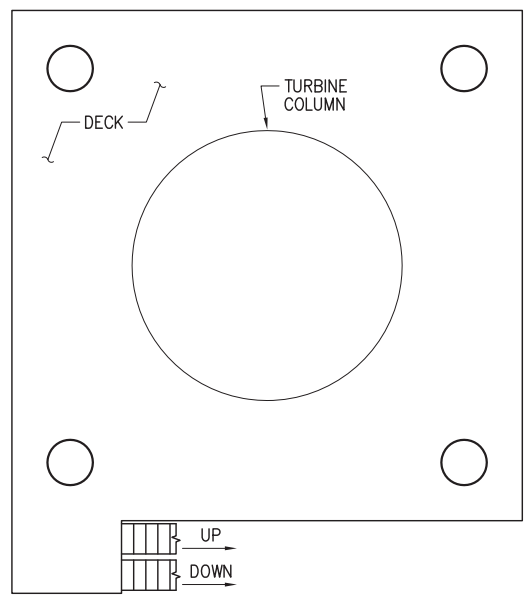

Upstream Engineering LLC
 "Providing Value Added Engineering Services"
 HOUSTON, TEXAS www.upstreamengineering.com (281) 531-0047



DETAILS AND SECTIONS

No.	DATE	REVISION	BY	APP.
B		REVISED ISSUED FOR PERMITTING	JR	
A	03/15/12	ISSUED FOR PERMITTING	JR	RS

DESIGNED BY: D. YBARRA	SCALE: 1/16"=1'-0"
DRAWN BY: J. RHAME	DATE: 03/08/12

PROJ. No.: P12-002
 FILENAME: 9010.dwg

Figure 4

REV. No.:
B

THIS DRAWING WAS PREPARED BY MOTT MACDONALD FOR A SPECIFIC PROJECT, TAKING INTO CONSIDERATION THE SPECIFIC AND UNIQUE REQUIREMENTS OF THE PROJECT. REUSE OF THIS DRAWING OR ANY INFORMATION CONTAINED IN THIS DRAWING FOR ANY PURPOSE IS PROHIBITED UNLESS WRITTEN PERMISSION FROM BOTH POWER AND POWER'S CLIENT IS GRANTED.

A	ISSUED FOR REVIEW	2/09/12	MT	CMD	CMD	
REV	REVISIONS	DATE	DRN	DSGN	CKD	APPD

LEGEND

- ① - CONDUCTOR
- ② - FILLING COMPOUND
- ③ - CONDUCTOR SCREEN
- ④ - INSULATION
- ⑤ - INSULATION SCREEN
- ⑥ - **LEAD ALLOY SHEATH**
- ⑦ - INTERSTITIAL FIBER OPTIC
- ⑧ - YARN FILLERS
- ⑨ - BINDER TAPES
- ⑩ - ARMOUR WIRES
- ⑪ - YARN AND BITUMEN

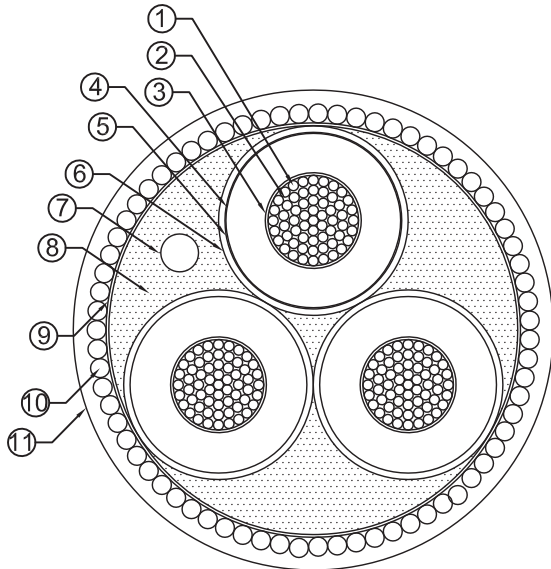

**35KV 3-CORE
SUBMARINE CABLE**

SUBMARINE_CABLE_DETAIL.dwg



	DSGN	CMD	02/09/2012
	DRN	MT	02/09/2012
	CKD	CMD	02/09/2012
	SCALE: N.T.S		
REFERENCE DRAWINGS	FOR 8.5x11 DWG ONLY		



DEEPWATER WIND	JOB NUMBER	REV
BLOCK ISLAND TRANSMISSION PROJECT	276847	A
TYPICAL 3-CORE SUBMARINE CABLE	Figure 5	

THIS DRAWING WAS PREPARED BY POWER ENGINEERS, INC. FOR A SPECIFIC PROJECT, TAKING INTO CONSIDERATION THE SPECIFIC AND UNIQUE REQUIREMENTS OF THE PROJECT. REUSE OF THIS DRAWING OR ANY INFORMATION CONTAINED IN THIS DRAWING FOR ANY PURPOSE IS PROHIBITED UNLESS WRITTEN PERMISSION FROM BOTH POWER AND POWER'S CLIENT IS GRANTED.

D	ISSUED FOR REVIEW	02/14/2012	JJS	JJS	DEJ	
C	ISSUED FOR REVIEW	02/03/2012	JJS	JJS	DEJ	
B	ISSUED FOR REVIEW	01/30/2012	JJS	JJS	DEJ	
A	ISSUED FOR REVIEW	01/17/2012	JJS	JJS	DEJ	
REV	REVISIONS	DATE	DRN	DSGN	CKD	APPD

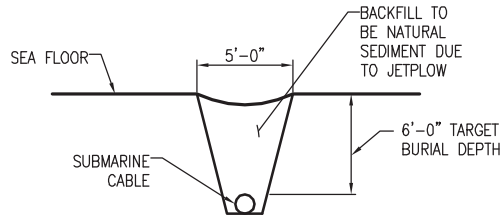

SECTION
SCALE N.T.S.

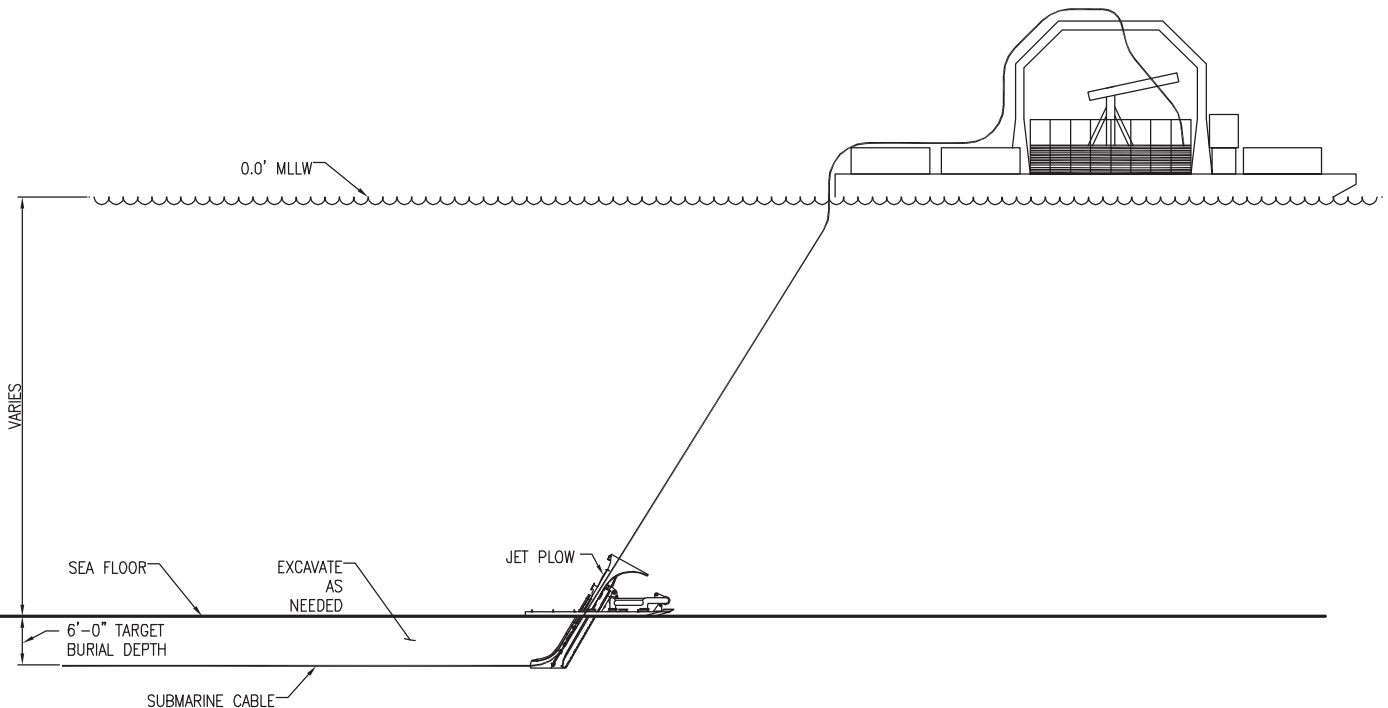

ELEVATION VIEW
SCALE N.T.S.



Submarine Detail.dwg

		DSGN	JJS	1/17/2012		DEEPWATER WIND	JOB NUMBER	REV
		DRN	JJS	1/17/2012		BLOCK ISLAND TRANSMISSION PROJECT	119630	△
		CKD	DEJ	1/17/2012		SUBMARINE DETAIL		D
REFERENCE DRAWINGS		SCALE:		N.T.S.			Figure 6	
				FOR 8.5x11 DWG ONLY				

THIS DRAWING WAS PREPARED BY POWER ENGINEERS, INC. FOR A SPECIFIC PROJECT, TAKING INTO CONSIDERATION THE SPECIFIC AND UNIQUE REQUIREMENTS OF THE PROJECT. REUSE OF THIS DRAWING OR ANY INFORMATION CONTAINED IN THIS DRAWING FOR ANY PURPOSE IS PROHIBITED UNLESS WRITTEN PERMISSION FROM BOTH POWER AND POWER'S CLIENT IS GRANTED.

B	ISSUED FOR REVIEW	04/16/2012	JJS	JJS	DEJ	
A	ISSUED FOR REVIEW	04/13/2012	JJS	JJS	DEJ	
REV	REVISIONS	DATE	DRN	DSGN	CKD	APPD

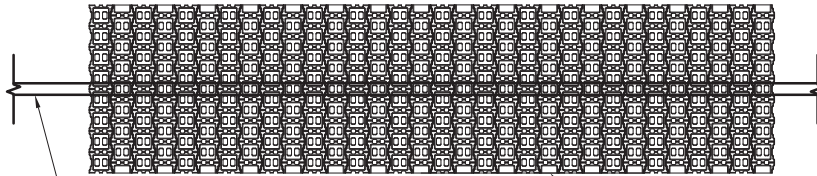

PROPOSED MARINE CABLE

CONCRETE MATS MAY BE INSTALLED OVER THE CABLE WHENEVER A MINIMUM OF 4'-0" OF COVER IS NOT ACHIEVED (SEE NOTE 1)

PLAN VIEW

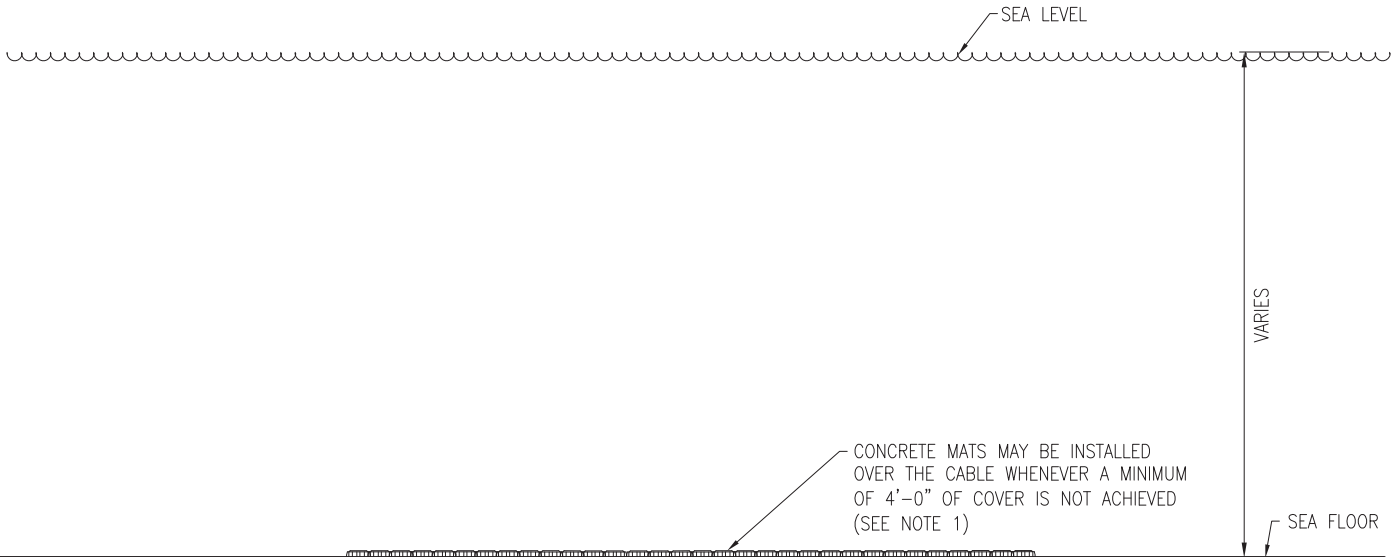

PROPOSED MARINE CABLE

CONCRETE MATS MAY BE INSTALLED OVER THE CABLE WHENEVER A MINIMUM OF 4'-0" OF COVER IS NOT ACHIEVED (SEE NOTE 1)

PROFILE VIEW

SHALLOW PENETRATION DETAIL

SCALE N.T.S.

NOTES:

1. ROCK DROPPING WITH SIMILAR PROFILE MAY BE USED IN LIEU OF CONCRETE MATS WHERE TARGER DEPTH WAS NOT ACHIEVED.

SHALLOW PENETRATION.dwg



		DSGN	JJS	04/13/2012
		DRN	JJS	04/13/2012
		CKD	DEJ	04/13/2012
		SCALE:	N.T.S.	
			FOR 8.5x11 DWG ONLY	
REFERENCE DRAWINGS				

DEEPWATER WIND	JOB NUMBER	REV
BLOCK ISLAND TRANSMISSION PROJECT	119630	B
SHALLOW PENETRATION DETAIL	Figure 7	

THIS DRAWING WAS PREPARED BY MOTT MACDONALD FOR A SPECIFIC PROJECT, TAKING INTO CONSIDERATION THE SPECIFIC AND UNIQUE REQUIREMENTS OF THE PROJECT. REUSE OF THIS DRAWING OR ANY INFORMATION CONTAINED IN THIS DRAWING FOR ANY PURPOSE IS PROHIBITED UNLESS WRITTEN PERMISSION FROM BOTH POWER AND POWER'S CLIENT IS GRANTED.

A	ISSUED FOR REVIEW	2/09/12	MT	CMD	CMD	
REV	REVISIONS	DATE	DRN	DSGN	CKD	APPD

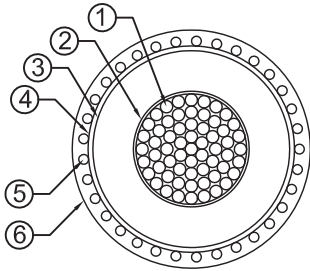

35KV URD
CABLE

LEGEND

- ① - CONDUCTOR
- ② - CONDUCTOR SCREEN
- ③ - INSULATION
- ④ - INSULATION SCREEN
- ⑤ - CONCENTRIC CONDUCTOR
- ⑥ - JACKET
- ⑦ - CONDUIT

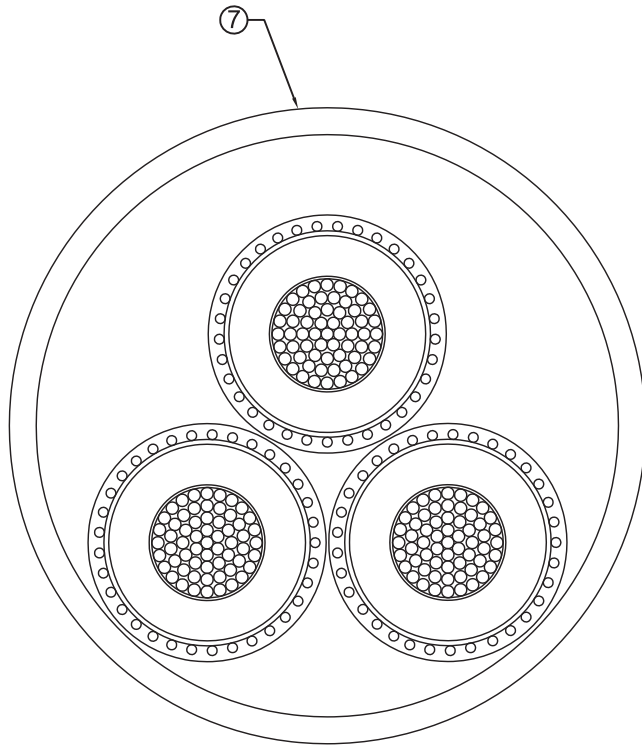

35KV CABLE
TREFOIL IN
CONDUIT

UPLAND CABLE DETAIL.dwg



	DSGN	CMD	02/09/2012
	DRN	MT	02/09/2012
	CKD	CMD	02/09/2012
	SCALE:		N.T.S
REFERENCE DRAWINGS	FOR 8.5x11 DWG ONLY		



DEEPWATER WIND	JOB NUMBER	REV
BLOCK ISLAND TRANSMISSION PROJECT	276847	△ A
TYPICAL UPLAND CABLE	Figure 8	

THIS DRAWING WAS PREPARED BY POWER ENGINEERS, INC. FOR A SPECIFIC PROJECT, TAKING INTO CONSIDERATION THE SPECIFIC AND UNIQUE REQUIREMENTS OF THE PROJECT. REUSE OF THIS DRAWING OR ANY INFORMATION CONTAINED IN THIS DRAWING FOR ANY PURPOSE IS PROHIBITED UNLESS WRITTEN PERMISSION FROM BOTH POWER AND POWER'S CLIENT IS GRANTED.

C	ISSUED FOR REVIEW	02/14/2012	JJS	JJS	DEJ	
B	ISSUED FOR REVIEW	02/03/2012	JJS	JJS	DEJ	
A	ISSUED FOR REVIEW	12/01/2011	JJS	JJS	DEJ	
REV	REVISIONS	DATE	DRN	DSGN	CKD	APPD

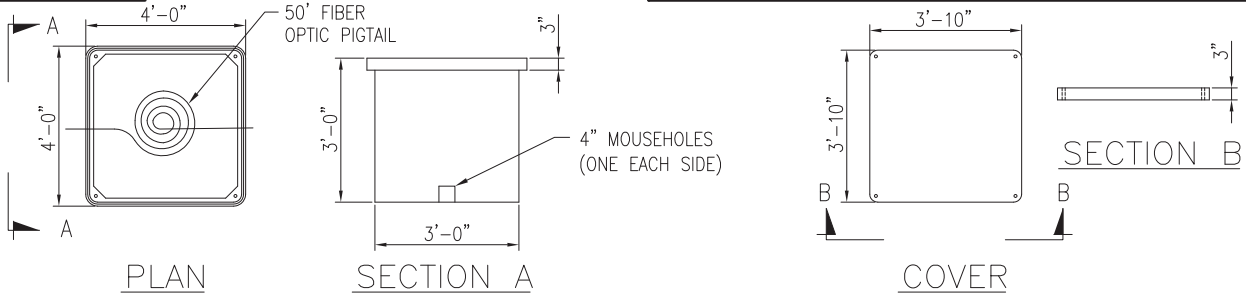

FIBER OPTIC HAND HOLE

NOTE
QUAZITE 48"x48" PG COVER AND BOX
MADE FROM POLYMER CONCRETE.

SCALE N.T.S.

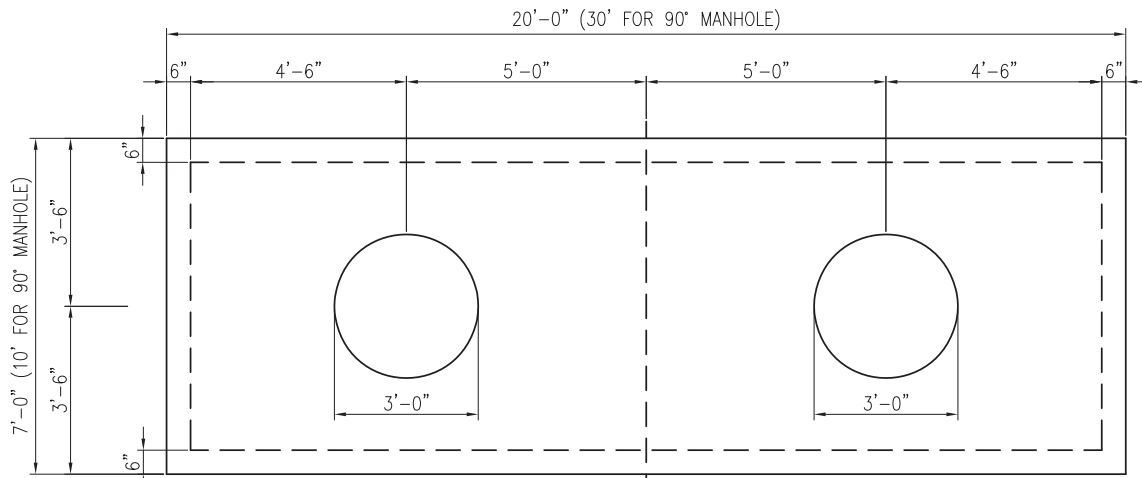

PLAN VIEW

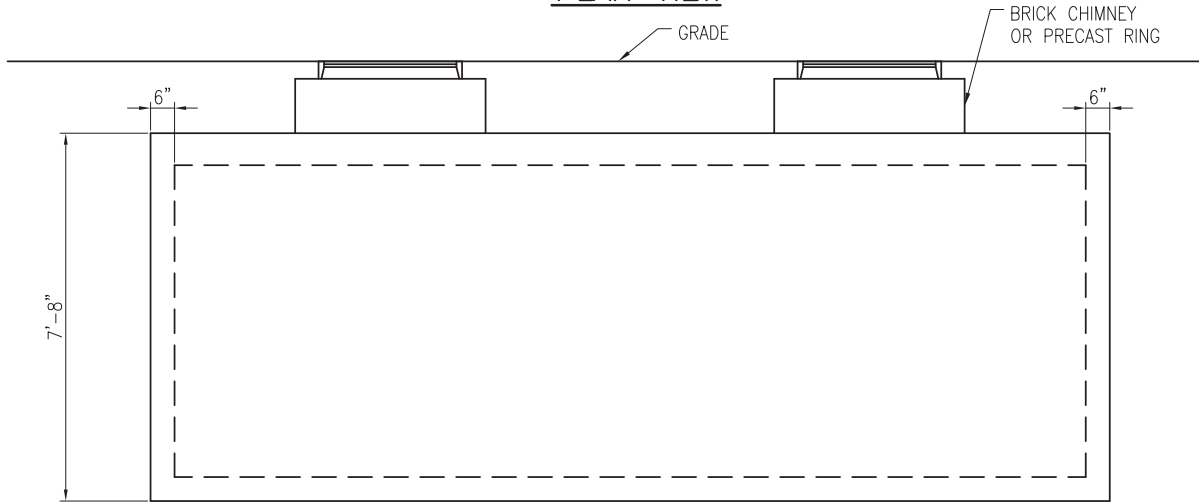

MANHOLE SECTION VIEW

"TYPICAL" NOT FOR CONSTRUCTION

SCALE N.T.S.



Manhole Detail.dwg

REFERENCE DRAWINGS	DSGN	JJS	12/01/2011		DEEPWATER WIND	JOB NUMBER	REV
	DRN	JJS	12/01/2011		BLOCK ISLAND TRANSMISSION PROJECT	119630	△
	CKD	DEJ	12/01/2011		TYPICAL MANHOLE DETAIL		
SCALE:		N.T.S.				Figure 9	
FOR 8.5x11 DWG ONLY							

THIS DRAWING WAS PREPARED BY POWER ENGINEERS, INC. FOR A SPECIFIC PROJECT, TAKING INTO CONSIDERATION THE SPECIFIC AND UNIQUE REQUIREMENTS OF THE PROJECT. REUSE OF THIS DRAWING OR ANY INFORMATION CONTAINED IN THIS DRAWING FOR ANY PURPOSE IS PROHIBITED UNLESS WRITTEN PERMISSION FROM BOTH POWER AND POWER'S CLIENT IS GRANTED.

REV	REVISIONS	DATE	DRN	DSGN	CKD	APPD
C	ISSUED FOR REVIEW	02/03/2012	JJS	JJS	DEJ	
B	ISSUED FOR REVIEW	01/30/2012	JJS	JJS	DEJ	
A	ISSUED FOR REVIEW	01/12/2012	JJS	JJS	DEJ	

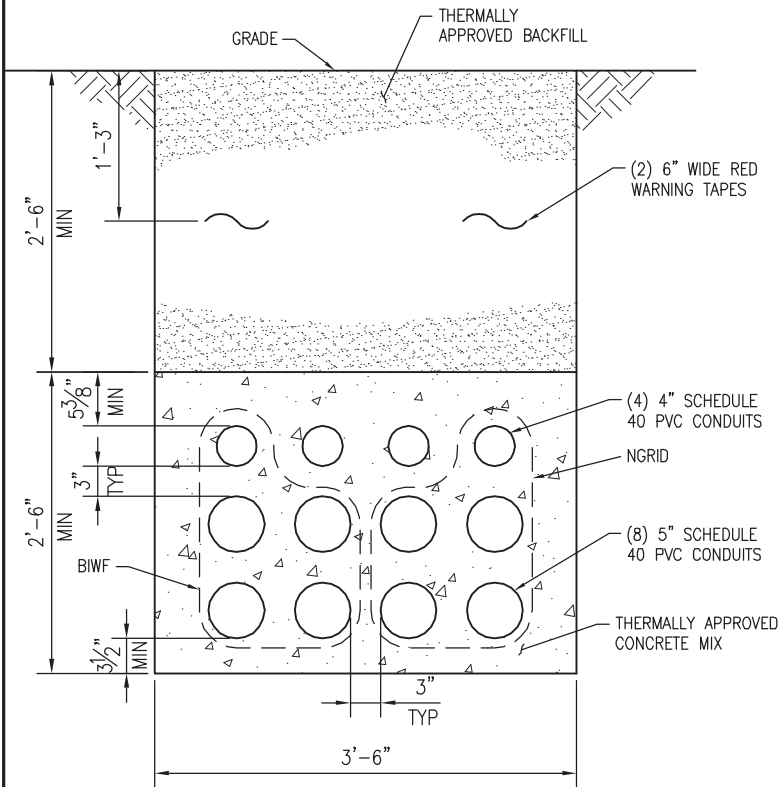

DOUBLE CIRCUIT SECTION
"TYPICAL" NOT FOR CONSTRUCTION

SCALE N.T.S.

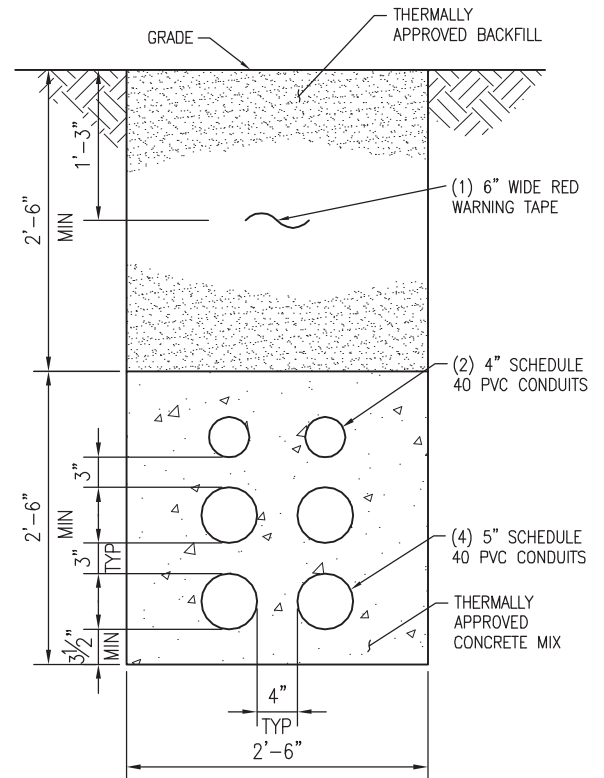

SINGLE CIRCUIT SECTION
"TYPICAL" NOT FOR CONSTRUCTION

SCALE N.T.S.

TRENCH DETAIL ALUMINUM.dwg



DSGN	JJS	01/12/2012
DRN	JJS	01/12/2012
CKD	DEJ	01/12/2012
SCALE:	N.T.S.	
FOR 8.5x11 DWG ONLY		



DEEPWATER WIND	JOB NUMBER	REV
BLOCK ISLAND TRANSMISSION PROJECT	119630	C
TRENCH DETAIL (ALUMINUM)	Figure 10	

JOB NUMBER	REV
119630	C
Figure 10	

THIS DRAWING WAS PREPARED BY POWER ENGINEERS, INC. FOR A SPECIFIC PROJECT, TAKING INTO CONSIDERATION THE SPECIFIC AND UNIQUE REQUIREMENTS OF THE PROJECT. REUSE OF THIS DRAWING OR ANY INFORMATION CONTAINED IN THIS DRAWING FOR ANY PURPOSE IS PROHIBITED UNLESS WRITTEN PERMISSION FROM BOTH POWER AND POWER'S CLIENT IS GRANTED.

D	ISSUED FOR REVIEW	02/14/2012	JJS	JJS	DEJ	
C	ISSUED FOR REVIEW	02/03/2012	JJS	JJS	DEJ	
B	ISSUED FOR REVIEW	01/30/2012	JJS	JJS	DEJ	
A	ISSUED FOR REVIEW	12/30/2011	JJS	JJS	DEJ	
REV	REVISIONS	DATE	DRN	DSGN	CKD	APPD

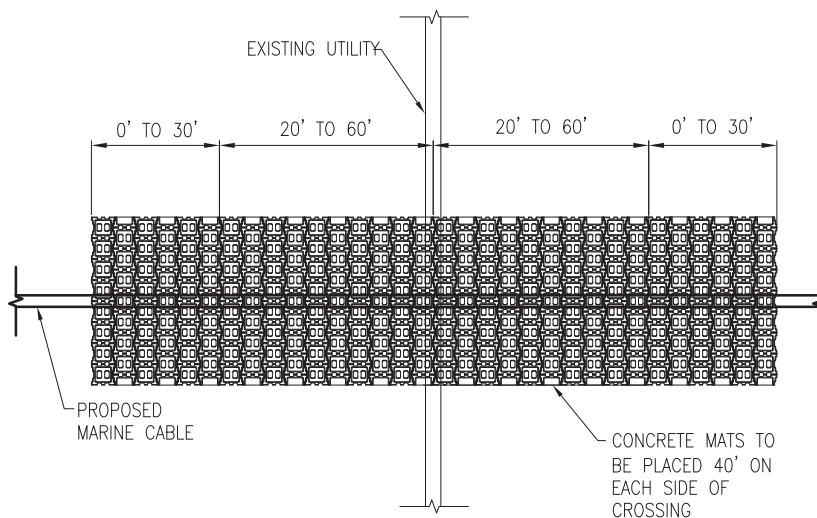

PLAN VIEW

EXISTING UTILITY CROSSING
SCALE N.T.S.

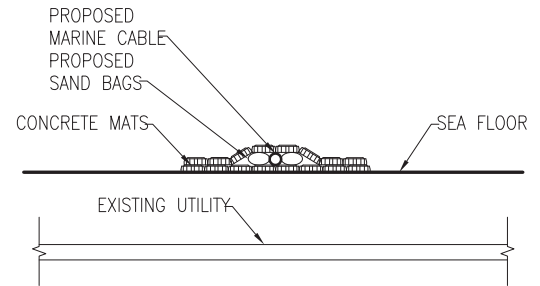

CROSS SECTION

EXISTING UTILITY CROSSING
SCALE N.T.S.

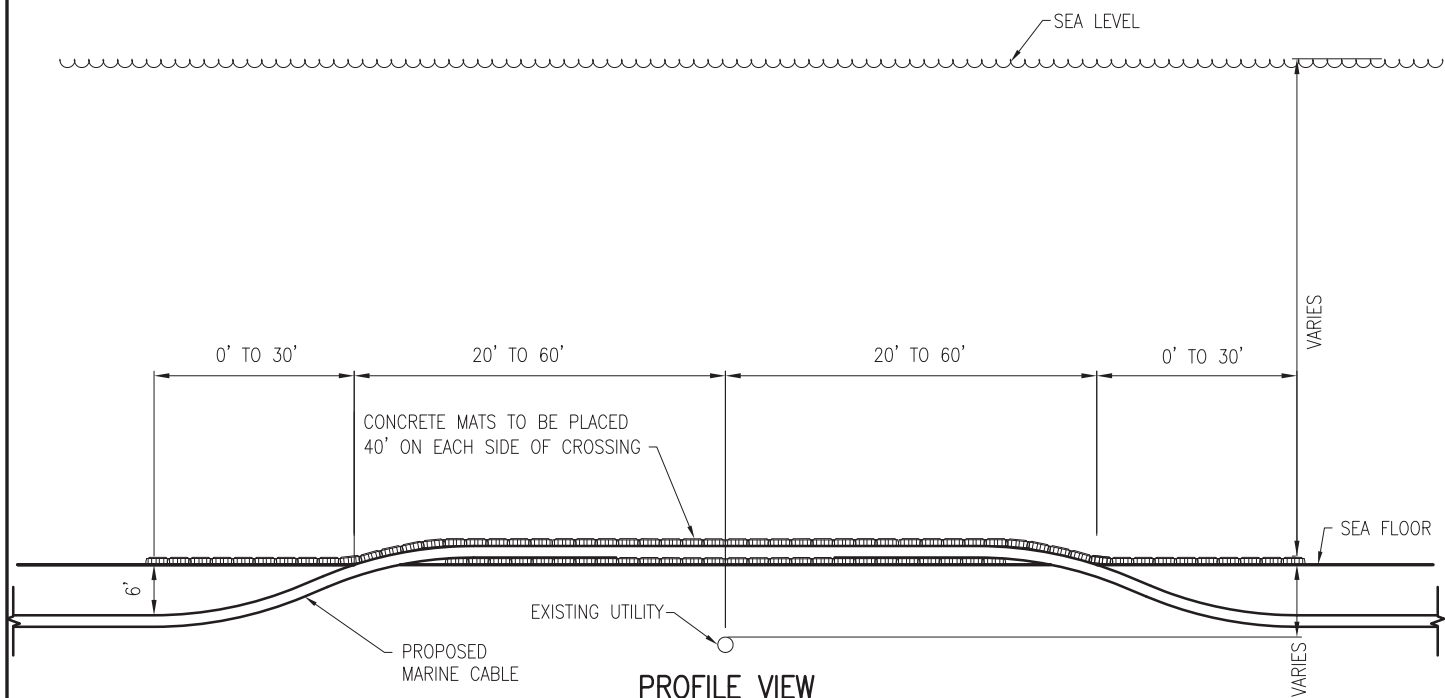

PROFILE VIEW

EXISTING UTILITY CROSSING
SCALE N.T.S.



DSGN	JJS	12/30/2011
DRN	JJS	12/30/2011
CKD	DEJ	12/30/2011
SCALE:	N.T.S.	
FOR 8.5x11 DWG ONLY		

DEEPWATER WIND	JOB NUMBER	REV
BLOCK ISLAND TRANSMISSION PROJECT	119630	D
TYPICAL OCEAN UTILITY CROSSING DETAIL	Figure 13	

UTILITY CROSSING.dwg

REFERENCE DRAWINGS

THIS DRAWING WAS PREPARED BY POWER ENGINEERS, INC. FOR A SPECIFIC PROJECT, TAKING INTO CONSIDERATION THE SPECIFIC AND UNIQUE REQUIREMENTS OF THE PROJECT. REUSE OF THIS DRAWING OR ANY INFORMATION CONTAINED IN THIS DRAWING FOR ANY PURPOSE IS PROHIBITED UNLESS WRITTEN PERMISSION FROM BOTH POWER AND POWER'S CLIENT IS GRANTED.

D	ISSUED FOR REVIEW	02/14/2012	JJS	JJS	DEJ	
C	ISSUED FOR REVIEW	02/03/2012	JJS	JJS	DEJ	
B	ISSUED FOR REVIEW	01/30/2012	JJS	JJS	DEJ	
A	ISSUED FOR REVIEW	01/12/2012	JJS	JJS	DEJ	
REV	REVISIONS	DATE	DRN	DSGN	CKD	APPD

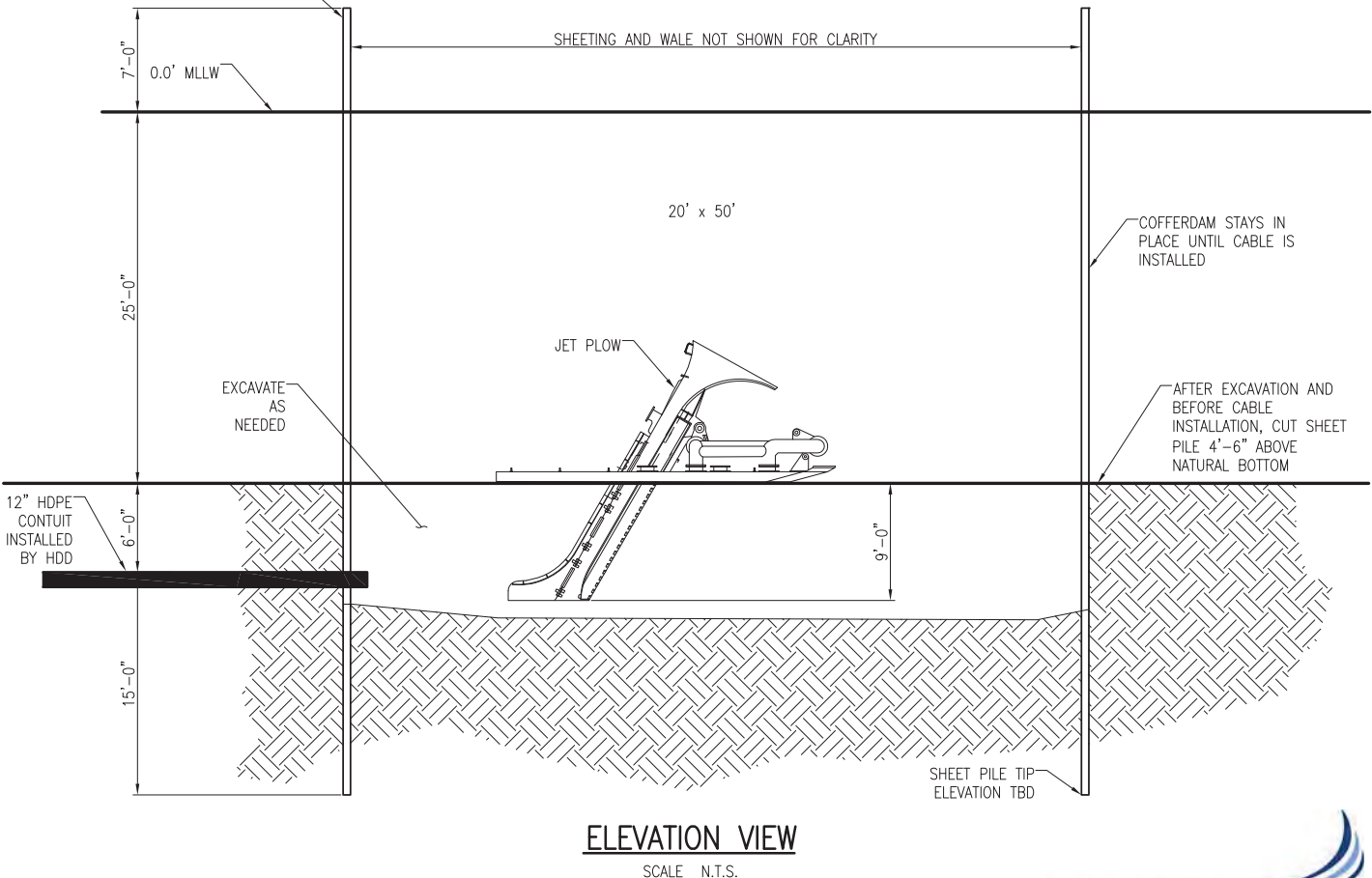
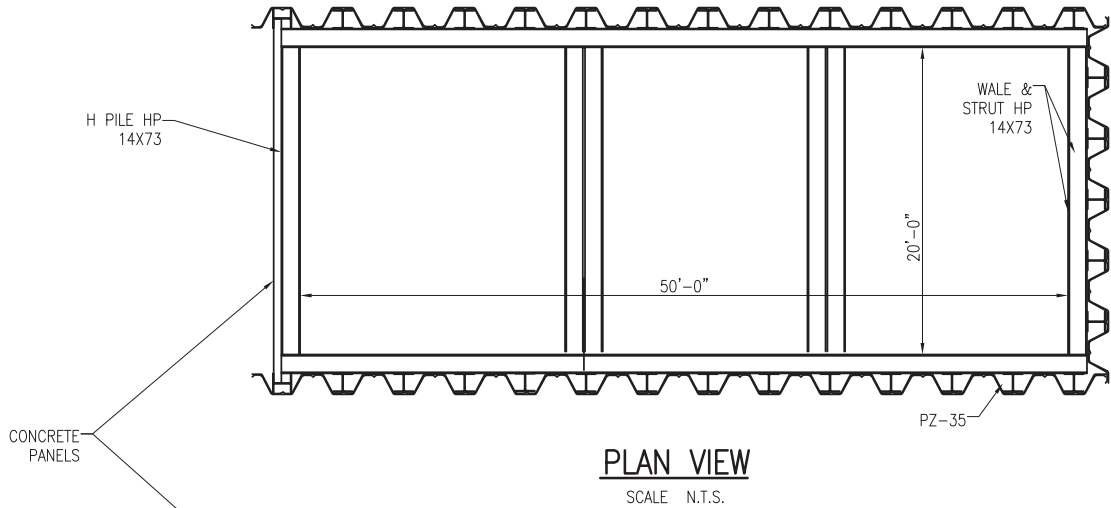

Coffer Dam Detail.dwg



DSGN	JJS	1/12/2012
DRN	JJS	1/12/2012
CKD	DEJ	1/12/2012
SCALE:	N.T.S.	
FOR 8.5x11 DWG ONLY		



DEEPWATER WIND	JOB NUMBER	REV
BLOCK ISLAND TRANSMISSION PROJECT	119630	D
COFFER DAM DETAIL	Figure 14	

JOB NUMBER	REV
119630	D
Figure 14	

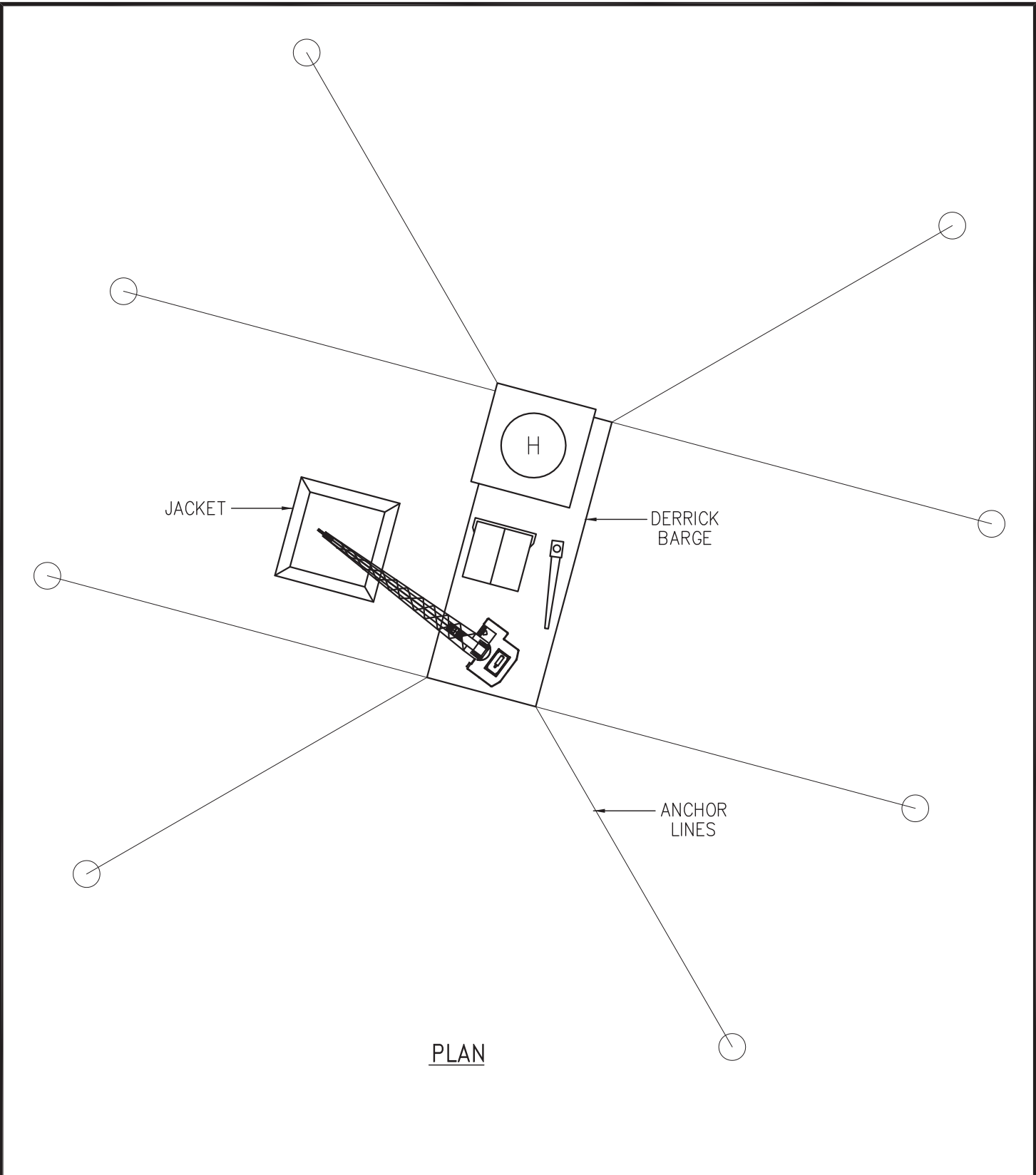

Upstream Engineering LLC

"Providing Value Added Engineering Services"
 HOUSTON, TEXAS www.upstreamengineering.com (281) 531-0047



Registration No.: F-2752

**JACKET INSTALLATION
 w/DERRICK BARGE**

No.	DATE	REVISION	BY	APP.
B	03/15/12	REVISED ISSUED FOR PERMITTING	JR	RS
A	01/24/12	ISSUED FOR PERMITTING	JR	RS

DESIGNED BY: D. YBARRA	SCALE: N.T.S.
DRAWN BY: J. RHAME	DATE: 01/11/12



PROJ. No.: P12-002
 FILENAME: 9004.dwg

Figure 15

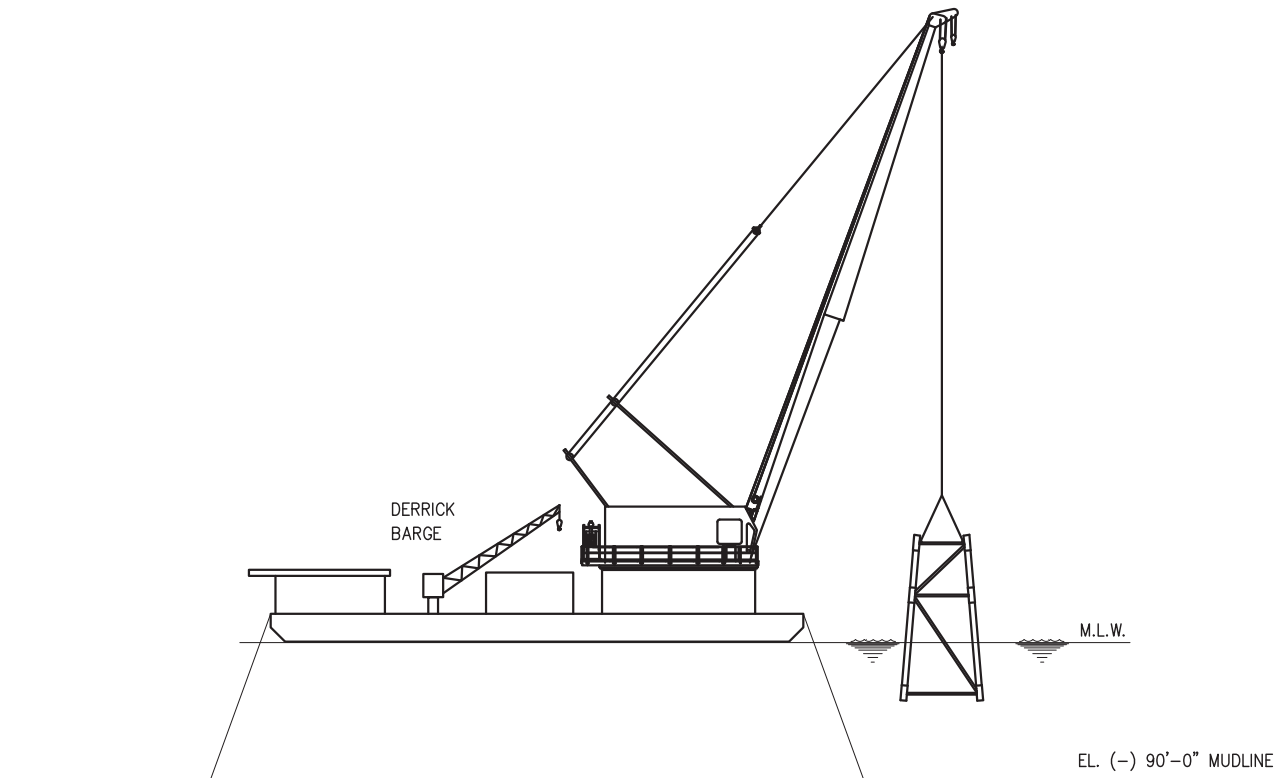
REV. No.:
B



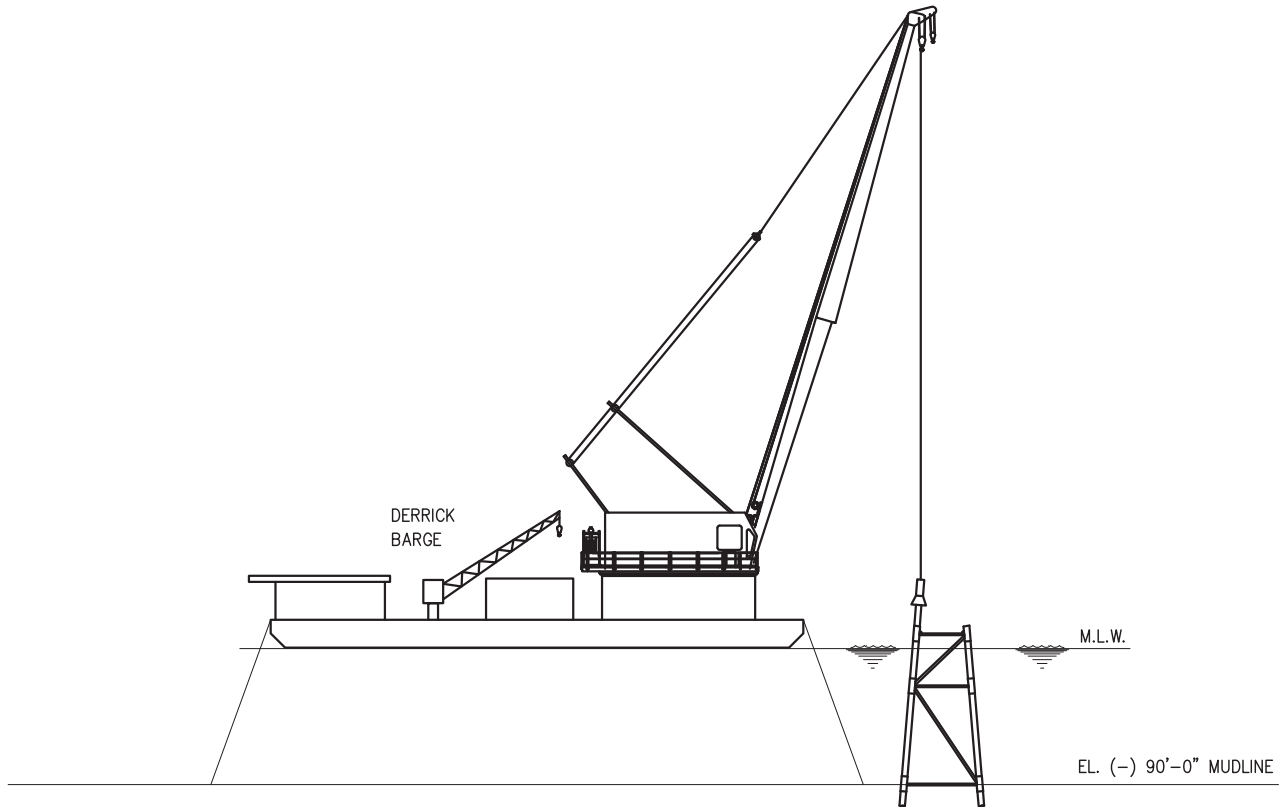

ELEVATION

 <p>Upstream Engineering LLC "Providing Value Added Engineering Services" HOUSTON, TEXAS www.upstreamengineering.com (281) 531-0047</p>					 <p>DEEPWATERWIND®</p>					
<p>Registration No.: F-2752</p>					<p>JACKET INSTALLATION w/DERRICK BARGE</p>					
C	03/15/12	REVISED ISSUED FOR PERMITTING	JR	RS						
B	01/26/12	REVISED ISSUED FOR PERMITTING	JR	RS						
No.	DATE	REVISION	BY	APP.						
DESIGNED BY: D. YBARRA		SCALE: 1/128"=1'-0"			PROJ. No.: P12-002		<p>Figure 16</p>		<p>REV. No.: C</p>	
DRAWN BY: J. RHAME		DATE: 01/11/12			FILENAME: 9005.dwg					



ELEVATION

 <p>Upstream Engineering LLC "Providing Value Added Engineering Services" HOUSTON, TEXAS www.upstreamengineering.com (281) 531-0047</p>					 <p>DEEPWATERWIND®</p>					
<p>Registration No.: F-2752</p>					<p>PILE DRIVING w/DERRICK BARGE</p>					
C	03/15/12	REVISED ISSUED FOR PERMITTING	JR	RS						
B	01/26/12	REVISED ISSUED FOR PERMITTING	JR	RS						
No.	DATE	REVISION	BY	APP.						
DESIGNED BY: D. YBARRA		SCALE: 1/128"=1'-0"								
DRAWN BY: J. RHAME		DATE: 01/11/12			PROJ. No.: P12-002		Figure 17		REV. No.: C	
					FILENAME: 9006.dwg					

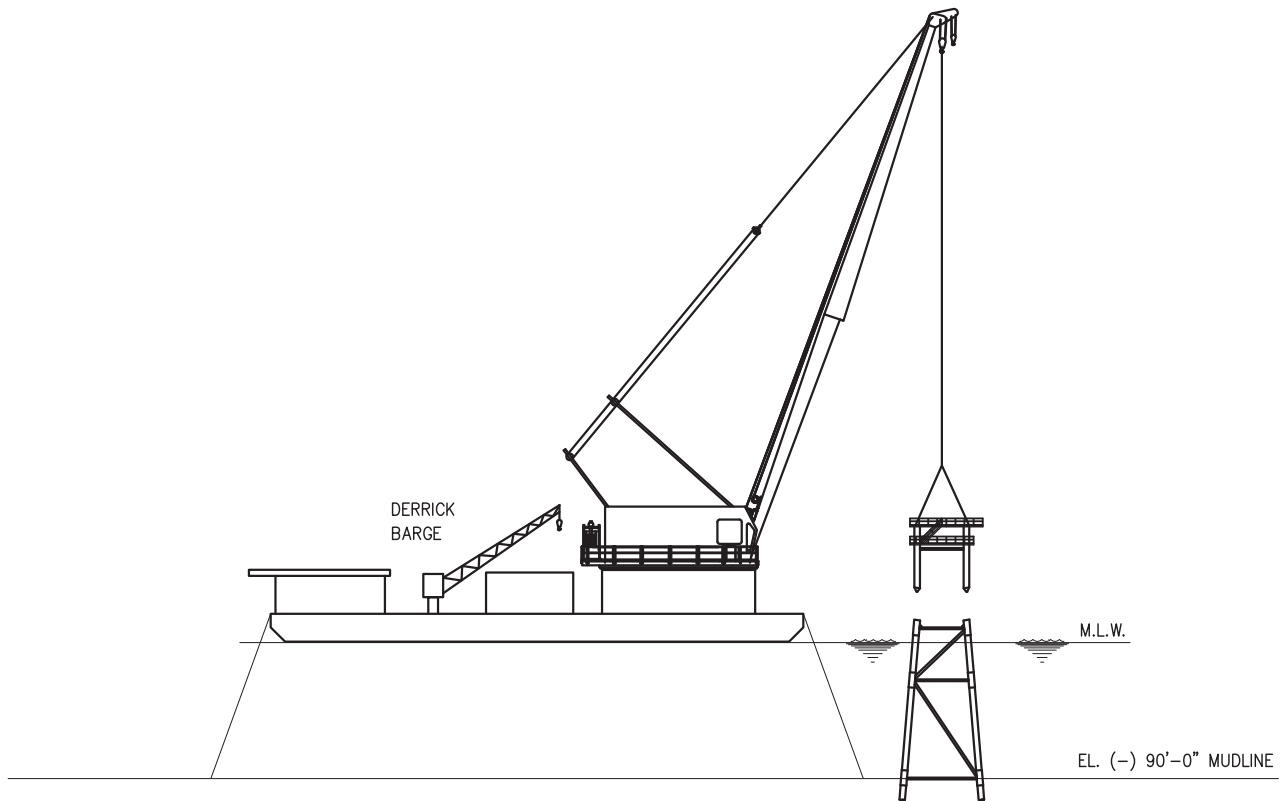

ELEVATION



Upstream Engineering LLC

"Providing Value Added Engineering Services"
 HOUSTON, TEXAS www.upstreamengineering.com (281) 531-0047

Registration No.: F-2752

No.	DATE	REVISION	BY	APP.
B	03/15/12	REVISED ISSUED FOR PERMITTING	JR	RS
A	01/24/12	ISSUED FOR PERMITTING	JR	RS

DESIGNED BY: D. YBARRA SCALE: 1/128"=1'-0"

DRAWN BY: J. RHAME DATE: 02/02/12



DECK INSTALLATION
w/DERRICK BARGE



PROJ. No.: P12-002
 FILENAME: 9007.dwg

Figure 18

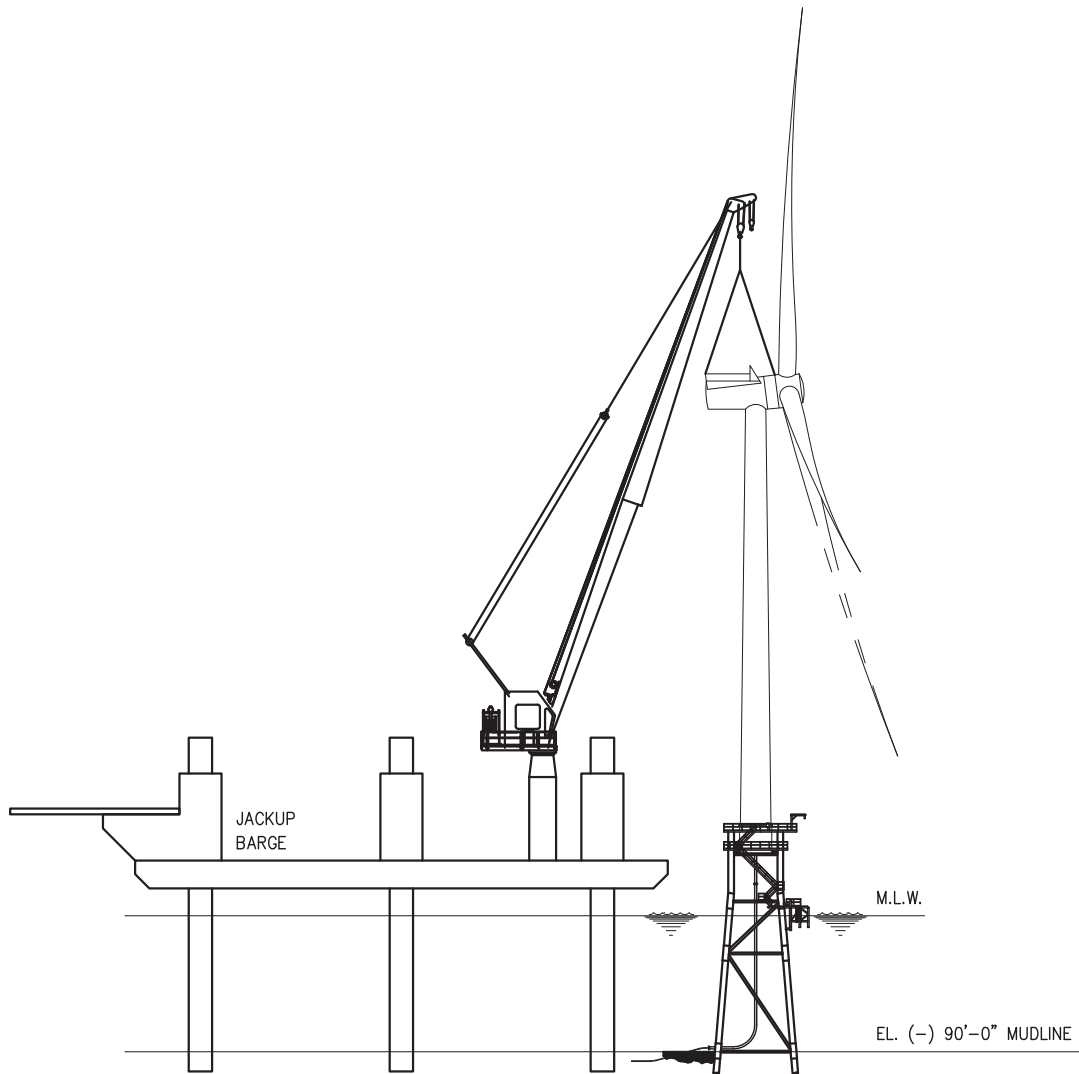
REV. No.: B



ELEVATION

 <p>Upstream Engineering LLC "Providing Value Added Engineering Services" HOUSTON, TEXAS www.upstreamengineering.com (281) 531-0047</p>					 <p>DEEPWATERWIND®</p>					
<p>Registration No.: F-2752</p>					<p>TURBINE INSTALLATION w/JACKUP BARGE</p>					
B	03/15/12	REVISED ISSUED FOR PERMITTING	JR	RS						
A	01/24/12	ISSUED FOR PERMITTING	JR	RS						
No.	DATE	REVISION	BY	APP.						
DESIGNED BY: D. YBARRA		SCALE: 1/128"=1'-0"								
DRAWN BY: J. RHAME		DATE: 01/11/12			PROJ. No.: P12-002		<p>Figure 19</p>		<p>REV. No.: B</p>	
FILENAME: 9008.dwg										

Appendix H: Turbine Foundation Scour Assessment Technical Report

The Turbine Foundation Scour Assessment Technical Report was provided as Appendix F in the report entitled “*Field Observations during Wind Turbine Foundation Installation at the Block Island Wind Farm, Rhode Island*” (HDR 2018).



Department of the Interior (DOI)

The Department of the Interior protects and manages the Nation's natural resources and cultural heritage; provides scientific and other information about those resources; and honors the Nation's trust responsibilities or special commitments to American Indians, Alaska Natives, and affiliated island communities.



Bureau of Ocean Energy Management (BOEM)

The mission of the Bureau of Ocean Energy Management is to manage development of U.S. Outer Continental Shelf energy and mineral resources in an environmentally and economically responsible way.

BOEM Environmental Studies Program

The mission of the Environmental Studies Program is to provide the information needed to predict, assess, and manage impacts from offshore energy and marine mineral exploration, development, and production activities on human, marine, and coastal environments. The proposal, selection, research, review, collaboration, production, and dissemination of each of BOEM's Environmental Studies follows the DOI Code of Scientific and Scholarly Conduct, in support of a culture of scientific and professional integrity, as set out in the DOI Departmental Manual (305 DM 3).